

RV 901 .. - RV 1001 ..
Twin Cavity Dual Fuel Cookers
Manual for Installation, Use and Maintenance

CDA

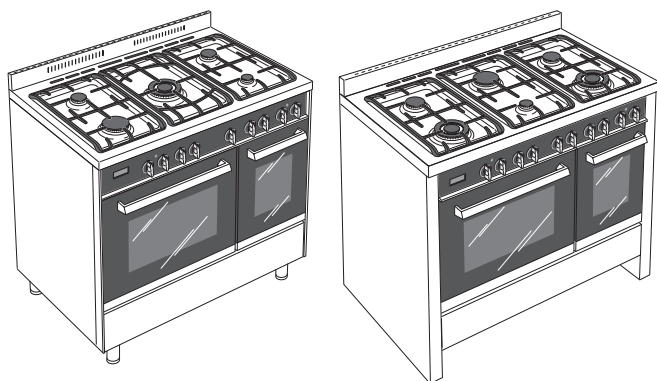

Important

This appliance is designed and manufactured solely for the cooking of domestic (household) food and is not suitable for any non domestic application and therefore should not be used in a commercial environment.

The appliance guarantee will be void if the appliance is used within a non domestic environment i.e. a semi commercial, commercial or communal environment.

The CDA Group Ltd cannot be held responsible for injuries or losses caused by incorrect use or installation of this product. Please note that CDA reserve the right to invalidate the guarantee supplied with this product following incorrect installation or misuse of the appliance.

Appliance information:

Please enter the details on the appliance rating plate below for reference, to assist CDA Customer Care in the event of a fault with your appliance and to register your appliance for guarantee purposes.

Appliance Model	<input type="text"/>
Serial Number	<input type="text"/>

Declaration of CE conformity

This cooker has been designed, constructed and marketed in compliance with:

- Safety requirements of EU Directive "Gas" 2009/142/EC;
- Safety requirements of EU Directive "Low Voltage" 2006/95/EC;
- Protection requirements of EU Directive "EMC" 2004/108/EC;
- Requirements of EU Directive 93/68/EEC.

Important information for correct disposal of the product in accordance with EC Directive 2002/96/EC.

At the end of its working life, the product must not be disposed of as urban waste. It must be taken to a special local authority differentiated waste collection centre or to a dealer providing this service.

Disposing of a household appliance separately avoids possible negative consequences for the environment and health deriving from inappropriate disposal and enables the constituent materials to be recovered to obtain significant savings in energy and resources. As a reminder of the need to dispose of household appliances separately, the product is marked with a crossed-out wheeled dustbin.



Features and Technical Data - mod. RV 901 ..

Gas Burners

- | | |
|----------------------------|---------|
| 1. Auxiliary burner (A) | 1.00 kW |
| 2. Semi-Rapid burner (SR) | 1.75 kW |
| 3. Semi-Rapid burner (SR) | 1.75 kW |
| 4. Rapid burner (R) | 3.00 kW |
| 5. Triple Ring burner (TR) | 3.50 kW |

Note:

The electric ignition is incorporated in the knobs.

The appliance has a safety valve system fitted, the flow of gas will be stopped if and when the flame should accidentally go out.

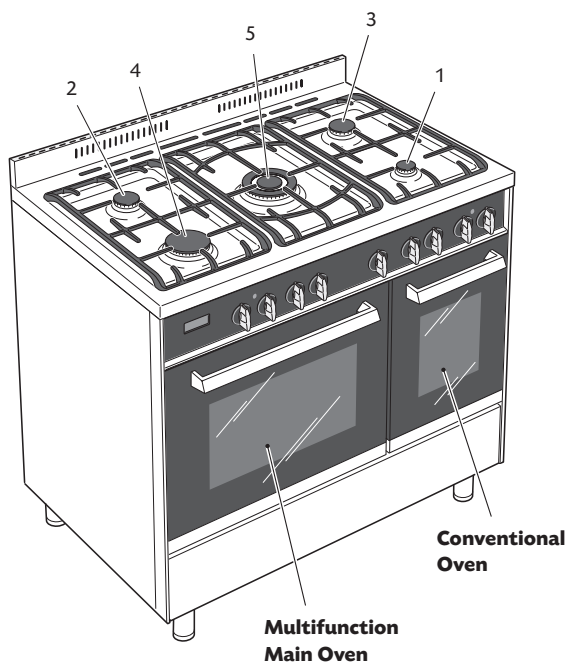

Fig. 1a

Features and Technical Data - mod. RV 1001 ..

Gas Burners

- | | |
|----------------------------|---------|
| 1. Auxiliary burner (A) | 1.00 kW |
| 2. Semi-Rapid burner (SR) | 1.75 kW |
| 3. Rapid burner (R) | 3.00 kW |
| 4. Triple Ring burner (TR) | 3.50 kW |

Note:

The electric ignition is incorporated in the knobs.

The appliance has a safety valve system fitted, the flow of gas will be stopped if and when the flame should accidentally go out.

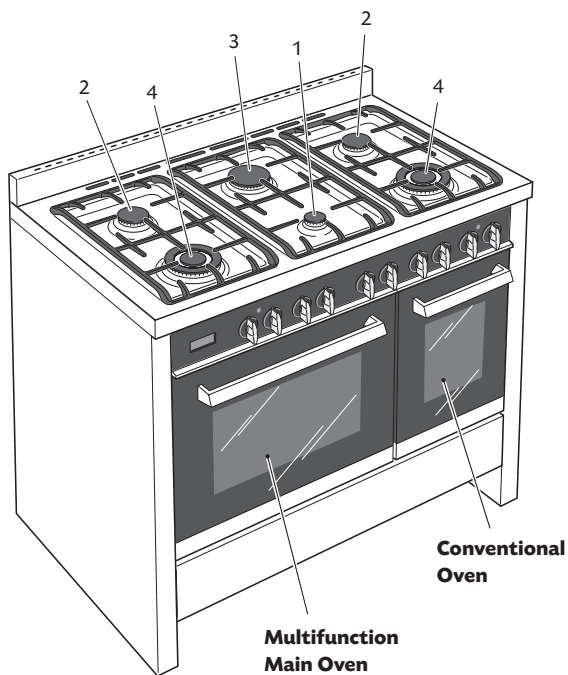

Fig. 1b

Control Panel

Controls Description

1. Front right burner control knob
2. Rear right burner control knob
3. Central rear burner control knob
4. Central front burner control knob
5. Rear left burner control knob
6. Front left burner control knob
7. Multifunction main oven switch knob
8. Multifunction main oven thermostat knob
9. Central burner control knob
10. Clock and timer with "Touch-Control" keys (main oven only)
11. Conventional oven thermostat knob
12. Conventional oven switch knob

Pilot Lamps:

13. Main oven thermostat indicator light
14. Conventional oven thermostat indicator light

Please note: This appliance incorporates a safety cooling fan which you will hear operating whenever the oven or grill are in use. The cooling fan may also operate when the oven is switched off. This fan is to reduce the external temperature of the appliance and cool the internal components.

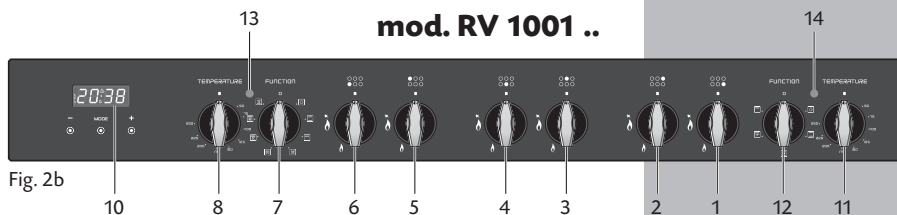
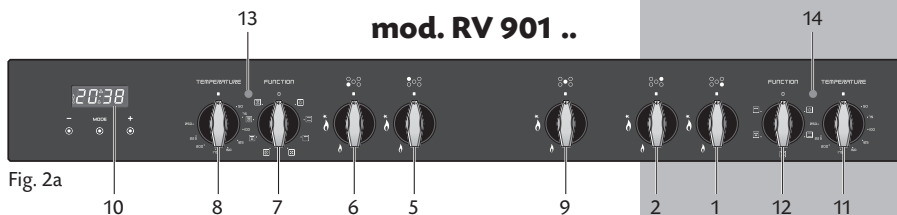

Clock and Timer with "Touch-Control" Keys

(Multifunction Main Oven only)

Keys:

- + and - Touched simultaneously (for more than 2 seconds):
- setting the clock;
 - setting the timer volume (by touching once, along with the "MODE" key);
 - to cancel automatic cooking at any time.

MODE Function selection (touched for more than 2 seconds):

- setting the clock (only after first connection or after a power failure);
- timer;
- automatic cooking "**dur**" (duration) - how long the food will take to cook (by touching the "MODE" key again);
- automatic cooking "**End**" - the time you would like the oven turns off (by touching the "MODE" key two more times);

+ Increases the number shown on the display

- Decreases the number shown on the display

Illuminated Symbols:

- AUTO** *flashing* - Automatic cooking completed, oven in automatic position but not set
- AUTO** *steady illumination* - Oven set for automatic cooking, cooking still not taking place
- "🕒" *flashing* - Timer being set
- "🕒" *steady illumination* - Timer in operation
- "🔥" *steady illumination* - Oven set for manual cooking
- "🔥" and **AUTO** *AUTO flashing* - Automatic cooking being set
- "🔥" and **AUTO** *steady illumination* - Oven set for automatic cooking, cooking taking place.



“Touch-Control” Keys

The “touch-control” keys shall be operated by the fingers (just by touching the key). When using touch controls it is best to use the ball of your finger rather than the tip.

The keys are automatically deactivated:

- 8 seconds after the last selection; the deactivation is indicated by an acoustic signal (“beep”).

To reactivate just touch the “**MODE**” key or the “+” and “-” keys.

Setting the Clock

When first connected, or after a power failure, the digits and “**AUTO**” will shown on the display. To set the clock, touch the “**MODE**” key, for more than 2 seconds, and then the “+” or “-” keys.

Important: The oven does not operate, in manual cooking, without first having set the clock.

To set the clock, with the appliance already connected, touch the “+” and “-” keys simultaneously (for more than 2 seconds), then “+” or “-” keys.

Important: - **changing the time will delete any automatic program;**
 - **after setting the clock, the oven starts to operate in the selected function (manual cooking). The “” symbol is steady illuminated.**

Using the Timer

You can use the timer at any time, even when the oven is not in use. The timer does not turn the oven off.

The timer can be set for up to 23 hours and 59 minutes.

- To set the timer, touch the “**MODE**” key for more than 2 seconds (the “” symbol flashes), than the “+” or “-” keys.

- After about 8 seconds an acoustic signal (“beep”) will sound confirming the regulation (“” symbol steady illuminated).

- To check the remaining time touch the “**MODE**” key for more than 2 seconds. If the remaining time is more than a minute the display will show hours and minutes; if less than a minute the display will show seconds.

- When the time is up, the timer will beep. Touch the “**MODE**” key, for more then 2 seconds, to turn it off; or press the “+” or “-” key to stop the beep and than the “**MODE**” key, for more than 2 seconds, to deactivate the “” symbol flashing on the display.

- Turn off the oven manually (function and thermostat knobs in the off position) if the manual cooking has been completed.

Setting the Timer Volume

You can select from three volume levels.

- Touch the “+” and “-” keys simultaneously for more than 2 seconds.

- Touch the “**MODE**” key; you can read on the display the current timer volume (“**ton1**”, “**ton2**” or “**ton3**”).

- Touch the “-” key to listen or change the timer volume.

- Timer volume activated: the last displayed.

- After about 8 seconds an acoustic signal (“beep”) will sound confirming the volume setting; then the time of day will be displayed.

Automatic Cooking

Use automatic cooking to automatically turn the oven on, cook, and then turn the oven off.

1. Check the clock shows the correct time.
2. Select the function and temperature (function and temperature knobs). The oven will come on.
3. Decide how long the food will take to cook, allowing time for preheating if necessary.
4. Touch the **"MODE"** key for more than 2 seconds and then touch again. **"dur"** will show (duration). Using the **"+"** and **"-"** keys, set the stop time.
5. Decide the time you would like the oven to turn off; touch the **"MODE"** key for more than 2 seconds and then touch it two times again. **"End"** will show. Using the **"+"** and **"-"** keys, set the stop time.

Note: While **"dur"** is displayed you can change to **"End"** just by touching one time the **"MODE"** key (within 8 seconds from the last selection).

If there is time to wait before cooking starts, the current time of day and **"AUTO"** will show in the clock display. The oven will switch off but is now set for automatic cooking.

If you are already at home to turn the oven on and only want the oven to turn off automatically, start cooking as normal, then follow step 4 or step 5 to set a time to stop the oven.

When automatic cooking starts,  will be displayed and the oven will turn on.

- To see the remaining cook time, follow step 4 up to display **"dur"** (duration).
- To see the set stop time, follow step 5 up to display **"End"**.
- To cancel automatic cooking at any time, touch the **"+"** and **"-"** keys simultaneously (for more than 2 seconds) and turn the temperature and function knobs to the off position.

When the stop time is reached, the oven will turn off, the timer will beep and **"AUTO"** will flash:





- Touch any key to stop the beeping.
- Touch the **"MODE"** key, for more than 2 seconds, to return the oven to the manual mode ( symbol steady illuminated on the display).
- Turn the temperature and function knobs to the off position.

Attention: after a power failure any automatic program is deleted. Turn off the oven manually.

How to Use the Hob Burners

Hob Burners

Each hob burner is controlled by a separate gas valve operated by a control knob (fig. 4) which has 3 positions marked on the control panel, these are:

- Symbol  : Tap closed (burner off)
- Symbol   : High (maximum)
- Symbol  : Low (minimum)

Push in and turn the knob anti-clockwise to the selected position.



The maximum aperture position permits rapid boiling of liquids, whereas the minimum aperture position allows slower warming of food or maintaining boiling conditions of liquids.

To reduce the gas flow to minimum, rotate the knob further anti-clockwise to point the indicator towards the small flame symbol. Other intermediate operating adjustments can be achieved by positioning the indicator between the maximum and minimum aperture positions, not between the maximum aperture and closed positions.

Note: When the hob is not being used, set the gas knobs to their closed positions and also close the cock valve on the gas bottle or the main gas supply line.

Lighting of the Hob Burners

To ignite the burner, the following instructions are to be followed:

- 1 - Press in the corresponding knob and turn counter-clockwise to the full flame position marked by the   symbol (fig. 4) and hold the knob in until the flame has been lit.
In the case of a mains failure light the burner with a match or lighted taper.
- 2 - Wait about ten seconds after the gas lighting before releasing the knob (starting time for the valve).
- 3 - Adjust the gas valve to the desired power.

Important

If the burner flame should go out for some reason, the safety valve will automatically stop the gas flow. To re-light the burner, return the knob to the closed  position, wait for at **least 1 minute** and then repeat the lighting procedure.

If your local gas supply makes it difficult to light the burner with the knob set to maximum, set the knob to minimum and repeat the operation.



Choice of Burner

The burner must be chosen according to the diameter of the pans and energy required. Saucepans with handles which are excessively heavy, in relationship to the weight of the pan, are safer as they are less likely to tip. Pans which are positioned centrally on burners are more stable than those which are offset. It is far safer to position the pan handles in such a way that they cannot be accidentally knocked.

When deep fat frying fill the pan only one third full of oil.

DO NOT cover the pan with a lid and DO NOT leave the pan unattended.

In the unfortunate event of a fire, leave the pan where it is and turn off all controls. Place a damp cloth or correct fitting lid over the pan to smother the flames.

DO NOT use water on the fire.

Leave the pan to cool for at least 30 minutes.

Do not use pans with concave or convex bases

Burner Size	Minimum Pan Diameter (cm)	Maximum Pan Diameter (cm)
Auxiliary	12	14
Semi-Rapid	16	24
Rapid (RV 901 .. model)	24	26
Rapid (RV 1001 .. model)	24	24
Triple Ring	26	28
Wok	-	36

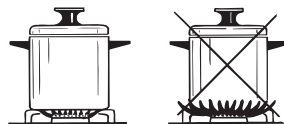
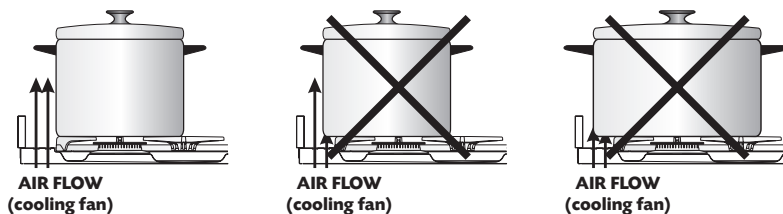

Fig. 5



CORRECT USE OF RAPID BURNER (mod. RV 1001 .. only)

Fig. 6

Correct Use of Triple-Ring Burner

The flat-bottomed pans are to be placed directly onto the pan-support.

To use the WOK you need to place the proper stand in order to avoid any faulty operation of the triple-ring burner (Figs. 7 - 8).

Important: The wok pan stand (fig. 8) **MUST BE PLACED ONLY** over the pan-rest for the triple-ring burner.

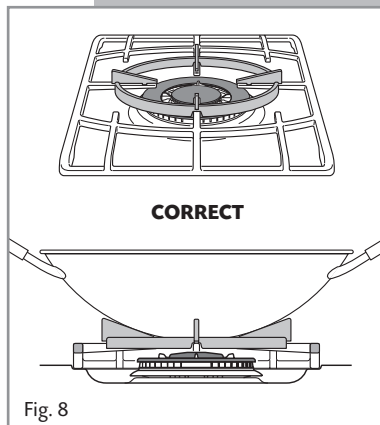
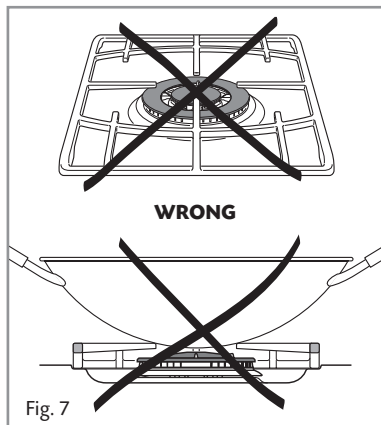

How to Use the Multifunction Main Oven

General Features



As its name indicates, this is an oven that presents particular features from an operational point of view.

In fact, it is possible to insert 7 different programmes to satisfy every cooking need.

The 7 positions, thermostatically controlled, are obtained by 4 heating elements which are:

- Bottom element 1200 W
- Top element 1000 W
- Grill element 2000 W
- Circular element 2200 W

Note:

Upon first use, it is advisable to operate the oven for 30 minutes in the position  and for another 30 minutes at the maximum temperature (thermostat knob on position 250) in the positions  and , to eliminate possible traces of grease on the heating elements.

Clean the oven and accessories with warm water and washing-up liquid.

WARNING:

The door is hot, use the handle.

ATTENTION - MOST IMPORTANT

Pay special attention not to touch the hot heating element inside the oven cavity.

Operating Principles

Heating and cooking in the MULTI-FUNCTION oven are obtained in the following ways:

a. by normal convection

The heat is produced by the upper and lower heating elements.

b. by forced convection

A fan sucks in the air contained in the oven muffle, which sends it through the circular heating element and then sends it back through the muffle. Before the hot air is sucked back again by the fan to repeat the described cycle, it envelops the food in the oven, provoking a complete and rapid cooking.

It is possible to cook several dishes simultaneously.

c. by semi-forced convection

The heat produced by the upper and lower heating elements is distributed throughout the oven by the fan.

d. by radiation

The heat is radiated by the infra red grill element.

e. by radiation and ventilation

The irradiated heat from the infra red grill element is distributed throughout the oven by the fan.

f. by ventilation

The food is defrosted by using the fan only function without heat.

Attention:

The oven door becomes very hot during operation.

Thermostat Knob (fig. 9)

This only sets the cooking temperature and does not switch the oven on.

Rotate clockwise until the required temperature is reached (from 50 to 250°C).

The light between the thermostat and the function selector will illuminate when the oven is switched on and turns off when the oven reaches the correct temperature.

The light will cycle on and off during cooking in line with the oven temperature.

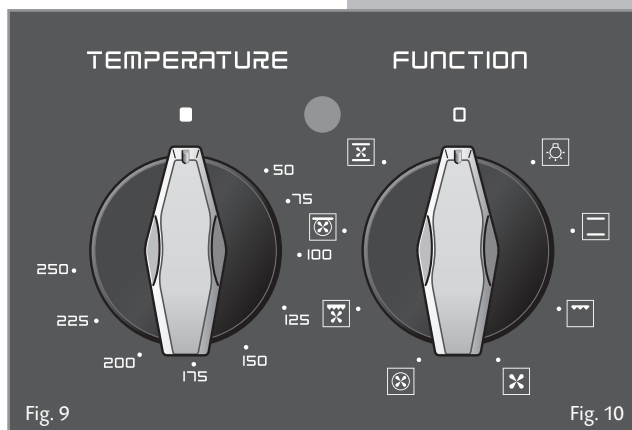

Function Selector knob (fig. 10)

Rotate the knob clockwise to set the oven for one of the following functions.



Oven Light

By setting the knob to this position, only the oven light comes on. It remains on in all the cooking modes.



Traditional Convection Cooking

The upper and lower heating elements come on. The heat is dispersed by natural convection and the temperature must be set to between 50° and 250°C via the thermostat knob.

The oven must be preheated before cooking.

Recommended for:

Food that requires the same degree of cooking both inside and out, for example roasts, spare pork ribs, meringues etc.



Grilling

The infrared grill element comes on. The heat is dispersed by radiation.

Use with the **oven door closed** and the thermostat knob to position **225°C** for max 15 minutes, then to position **175°C**.

For cooking hints, see the chapter "USE OF THE GRILL".

Recommended for:

Intense grilling, browning, cooking au gratin and toasting etc.

It is recommended that you do not grill for longer than 30 minutes at any one time.

Caution: the oven door becomes very hot during operation. Keep children well out of reach.



Defrosting Frozen Foods

Only the oven fan comes on. Use with the thermostat knob set to "■" - other positions have no effect. The food is thawed by ventilation without heating.

Recommended for:

Quick thawing of frozen foods; one kg requires approximately 1 hour.

Thawing times vary according to the quantity and type of food to be thawed.



Hot Air Cooking

The circular element and fan come on. The heat is dispersed by forced convection and the temperature can be regulated to between 50° and 250°C via the thermostat knob. The oven does not require preheating.

Recommended for:

Food which has to be well-cooked outside and soft or rosy inside, for example lasagne, lamb, roast beef, whole fish etc.



Ventilated Grill Cooking

The infrared grill element and the fan come on. The heat is dispersed mainly by radiation and the fan then distributes it all over the oven.

Use with the door closed. The temperature can be regulated via the thermostat knob to between 50° and 175° max.

The oven must be preheated for approximately 5 minutes. For cooking hints, see the chapter "GRILLING AND AU GRATIN."

Recommended for:

Grilling where quick browning on the outside is required to keep the juices in.

For example: veal steaks, chops, hamburgers etc.

It is recommended that you do not grill for longer than 30 minutes at any one time.

Caution: the oven door becomes very hot during operation. Keep children well out of reach.



Maintaining Temperature After Cooking or Slowly Heating Foods

The upper heating element, the circular element and the fan come on.

The heat is dispersed by forced convection with greater intensity in the upper part.

The temperature can be set to between 50° and 150°C via the thermostat knob.

Recommended for:

Keeping food warm after any type of cooking. Slow heating of cooked food.



Convection Cooking with Ventilation

The upper and lower heating elements come on and the fan.

The heat coming from above and below is dispersed by convection with ventilation.

The temperature can be set to between 50° and 250°C via the thermostat knob.

Recommended for:

Voluminous dishes and large quantities which require the same degree of cooking both inside and out, for example rolled roasts, turkey, roast legs, cakes etc.

Cooking Advice

Sterilization

Sterilization of foods to be conserved, in full and hermetically sealed jars, is done in the following way:

- Set the switch to position .
- Set the thermostat knob to position 185 °C and preheat the oven.
- Fill the dripping pan with hot water.
- Set the jars onto the dripping pan making sure they do not touch each other and the door and set the thermostat knob to position 135 °C.



When sterilization has begun, that is, when the contents of the jars start to bubble, turn off the oven and let cool.

Regeneration

Set the switch to position  and the thermostat knob to position 150° C.

Bread becomes fragrant again if wet with a few drops of water and put into the oven for about 10 minutes at the highest temperature.

Simultaneous Cooking of Different Foods

The MULTI-FUNCTION oven set on position  and  gives a simultaneous heterogeneous cooking of different foods. Different foods such as fish, cake and meat can be cooked together without mixing the smells and flavors together. This is possible since the fats and vapors are oxidized while passing through the electrical element and therefore are not deposited onto the foods.

The only precaution to follow are:

- The cooking temperatures of the different foods must be as close to as possible, with a maximum difference of 20° - 25 °C.
- The introduction of the different dishes in the oven must be done at different times in relation to the cooking times of each one.

The time and energy saved with this type of cooking is obvious.

Grilling and "Au Gratin"

Grilling may be done without the roasting rack on position  of the switch, because the hot air completely envelops the food that is to be cooked.

Set the thermostat to position 175 °C and after having preheated the oven, simply place the food on the rack.

Close the door and let the oven operate with the thermostat on position 175 °C, until grilling is done.

Adding a few dabs of butter before the end of the cooking time gives the golden "au gratin" effect.

Grilling with the oven door closed.

It is recommended that you do not grill for longer than 30 minutes at any one time.

Caution: the oven door becomes very hot during operation. Keep children well out of reach.

Roasting

To obtain classical roasting, it is necessary to remember:

- that it is advisable to maintain a temperature between 180° and 200 °C.
- that the cooking time depends on the quantity and the type of foods.

Use of the Grill

- Preheat the oven for about 5 minutes.
- Introduce the food to be cooked, positioning the rack as close to the grill as possible.
- The dripping pan should be placed under the rack to catch the cooking juices and fats.

Grilling with the oven door closed.

Do not grill for longer than 30 minutes at any one time.

Caution: the oven door becomes very hot during operation. Keep children well out of reach.



How to Use the Conventional Oven

General Features

As its name indicates, this is an oven that presents particular features from an operational point of view. The conventional oven is provided with 3 heating elements which are:

- Bottom element 800 W
- Top element 700 W
- Grill element 1450 W

Note:

Upon first use, it is advisable to operate the oven at the maximum temperature (thermostat knob on position 250) for 60 minutes in the position  and for another 15 minutes in the position  to eliminate possible traces of grease on the heating elements. liquid.

WARNING:

The door is hot, use the handle.

ATTENTION - MOST IMPORTANT

Pay special attention not to touch the hot heating element inside the oven cavity.

Thermostat Knob (fig. 12)

This only sets the cooking temperature and does not switch the oven on.

Rotate clockwise until the required temperature is reached (from 50 to 250°C).

The light between the thermostat and the function selector will illuminate when the oven is switched on and turns off when the oven reaches the correct temperature.

The light will cycle on and off during cooking in line with the oven temperature.

Attention:

The oven door becomes very hot during operation.

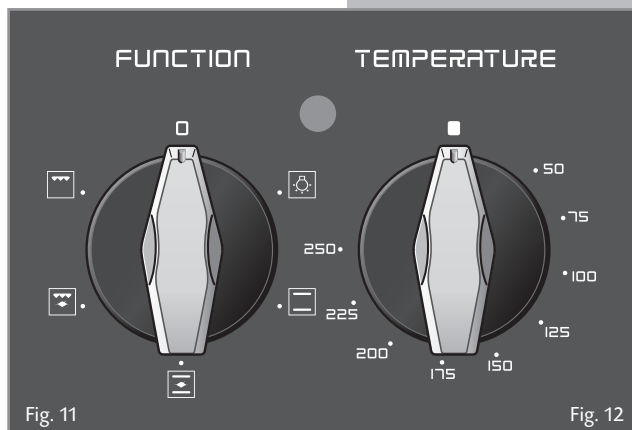

Fig. 11

Fig. 12

Function Selector Knob (fig. 11)

Rotate the knob clockwise to set the oven for one of the following functions.



Oven Light

By setting the knob to this position, only the oven light comes on. It remains on in all the cooking modes.



Traditional Convection Cooking

The upper and lower heating elements come on.

The heat is dispersed by natural convection and the temperature must be set to between 50° and 250°C via the thermostat knob. The oven must be preheated before cooking.

In the  position the rotisserie motor come on for cooking with the rotisserie.

Recommended for:

Food that requires the same degree of cooking both inside and out, for example roasts, spare pork ribs, meringues etc.



Traditional Grilling

The infrared grill element comes on. The heat is dispersed by radiation.

Use with the **oven door closed** and the thermostat knob to position **225°C** for max 15 minutes, then to position **175°C**.

In the  position the rotisserie motor come on for cooking with the rotisserie.

For cooking hints, see the chapter "USE OF THE GRILL".

Recommended for:

Intense grilling, browning, cooking au gratin and toasting etc.



It is recommended that you do not grill for longer than 30 minutes at any one time.

Caution: the oven door becomes very hot during operation.

Keep children well out of reach.

Use of the Grill

Switch the grill on, setting the two knobs:

- Function selector to  or  position.
- Thermostat selector to position **225°C** for 15 minutes then to **175°C**.

Leave to warm up for approximately 5 minutes with the door **closed**.

Place the food inside positioning the rack as near as possible to the grill.

Insert the drip pan under the rack to collect the cooking juices.

Grilling with the oven door closed and **do not for longer than 30 minutes at any one time**.

Attention: the oven door becomes very hot during operation.

Keep children away.

Rotisserie

The oven is equipped with a rotisserie.

This device is made up of:

- an electrical motor mounted on the rear part of the oven
- a stainless steel rod, equipped with a detachable athermic handle and 2 recordable forks
- a rod support to be inserted into the central rack holders of the oven.

Use of the Rotisserie

- Insert the dripping pan into the lowest rack holders of the oven and insert the rod support into the intermediate rack holders.
- Put the meat to be cooked onto the rod, being careful to secure it in the center with the special forks.
- Insert the rod into the motor opening and rest it onto the support of the spit collar; then remove the grip by turning it to the left.

The rotation direction of the rotisserie can be either clockwise or counter-clockwise.

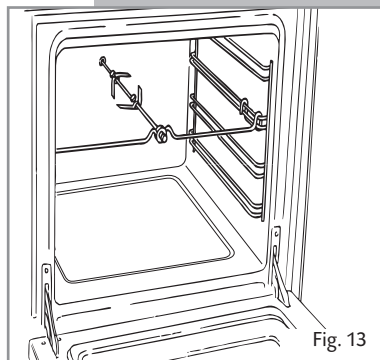

Fig. 13

Use of Special Dish Rack

This special shelf can be used as dish rack or turning over, as normal shelf for oven cooking. It must be inserted between the guides of the lateral racks.

Using the Special Shelf as a Dish Rack

Slide in the shelf on the guides, on the lower level of the lateral racks.

The prongs where the plates are to be inserted, must be turned upwards.

The shelf must be fitted so that the safety catch, which stops it sliding out, faces the bottom of the oven (see detail of figure 14).

The plates must be positioned as indicated in figure 14.

To facilitate this operation, pull the special rack up to the safety lock.

KEEP Attention: Plates are hot after warming. It is advisable to handle the plates using oven gloves.

Using the Special Rack for Normal Cooking

Slide in the shelf on the guides: the safety catch must be turned toward the oven base (see detail of figure 15).

The flat surface can be used to put cooking pans or food directly on the rack - the dripping pan should be placed under the rack to catch the cooking juices and fats.

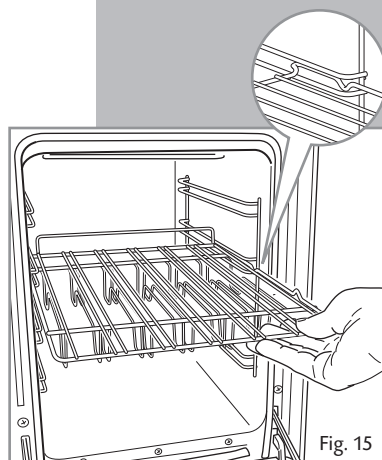
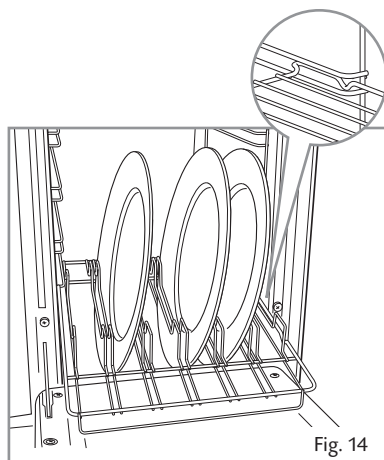

Do's and do not's

- Do always grill with the oven door closed.
- Do read the user instructions carefully before using the cooker for first time.
- Do allow the oven to heat for one and a half hours, before using for the first time, in order to expel any smell from the new oven insulation, without the introduction of food.
- Do clean your oven regularly.
- Do remove spills as soon as they occur.
- Do always use oven gloves when removing food shelves and trays from the oven.
- Do not allow children near the cooker when in use.
- Do not allow fat or oils to build up in the oven trays, or oven base.
- Do not place cooking utensils or plates directly onto the oven base.
- Do not grill food containing fat without using the grid.
- Do not cover the grilling grid with aluminium-foil.
- Do not use the oven tray for roasting.
- Do not place hot enamel parts in water. Leave them to cool first.
- Do not allow vinegar, coffee, milk, saltwater, lemon or tomato juice to remain in contact with enamel parts (inside the oven and on the oven tray).
- Do not use abrasive cleaners or powders that will scratch the surface of the stainless steel and the enamel.
- Do not attempt to repair the internal workings of your cooker.
- Do remove the protective film before the first use.
- **Fire risk!** Do not store flammable material in the ovens and in the storage compartment (RV 901 .. model) or bottom drawer (RV 1001 .. model).

For Your Safety

- The product should only be used for its intended purpose which is for the cooking of domestic foodstuffs.
- Under no circumstances should any external covers be removed for servicing or maintenance except by suitably qualified personnel.
- **Attention: The appliance gets very hot, mainly around the cooking areas. It is very important that children are not left alone in the kitchen when you are cooking.**
- Household appliances are not intended to be played with by children.
- Keep children away from the appliance during use.
- Children, or persons with a disability which limits their ability to use the appliance, should have a responsible person to instruct them in its use. The instructor should be satisfied that they can use the appliance without danger to themselves or their surroundings.
- Do not operate your appliance by means of an external timer or separate remote-control system.

Important Notes

Installation, and any demonstration, information or adjustments are not included in the warranty. The cooker must be installed by a suitably qualified and registered person in accordance with the relevant Standards.

Care and Maintenance

Important:

As a safety measure, before you start cleaning the cooker be sure to disconnect it from the mains supply.

Do not use cleaning products with a chlorine or acidic base.

Do not use a steam cleaner because the moisture can get into the appliance thus make it unsafe.

The use of suitable protective clothing/gloves is recommended when handling or cleaning of this appliance.

Warning

When correctly installed, your product meets all safety requirements laid down for this type of product category.

However special care should be taken around the rear or the underneath of the appliance as these areas are not designed or intended to be touched and may contain sharp or rough edges, that may cause injury.

Flexible Tube

From time to time, check the flexible tube connecting the gas supply to the cooker.

It must be always in perfect condition; in case of damage arrange for it to be replaced by a suitably qualified and registered installer.

Gas Taps

If a tap becomes stiff, **do not force**; contact your Local Service Centre.

Cleaning the Hob

Spillage on the hob can usually be removed by a damp soapy cloth. More obstinate stains can be removed by rubbing gently with a soapy nylon (non metal) scouring pad or mild household cleaner.

Enamelled Parts

All the enamelled parts must be cleaned with a sponge and soapy water only or other non-abrasive products.

Dry preferably with a micro fibre or soft cloth.

Stainless Steel, Aluminium, Painted Parts and Silk-Screen Printed Surfaces

Clean using an appropriate product. Always dry thoroughly.

Stainless steel surfaces: can be cleaned with an appropriate stainless steel cleaner.

IMPORTANT: these parts must be cleaned very carefully to avoid scratching and abrasion. You are advised to use a soft cloth and neutral soap.

CAUTION: Do not use abrasive substances or non-neutral detergents as these will irreparably damage the surface.

Glass Control Panel

Clean using an appropriate product.

Always dry thoroughly.

Do not use harsh abrasive cleaners or sharp metal scrapers to clean the control panel since they can scratch the surface, which may result in shattering of the glass.

Burners and Grids

- These parts can be removed and cleaned with appropriate products.
- After cleaning, the burners and their flame spreaders must be well dried and correctly replaced.
- It is very important to check that the burner flame spreader and the cap have been correctly positioned. Failure to do so can cause serious problems.
- Check that the electrode "S" (figs. 16-18) is always clean to ensure trouble-free sparking.
- Check that the sensor "T" (figs. 16-18) next to each burner is always clean to ensure correct operation of the safety valves.
- Both the sensor and ignition plug must be very carefully cleaned.
- **Note: To avoid damage to the electric ignition do not use it when the burners are not in place.**

Correct Positioning of the Burners (Auxiliary, Semi-Rapid and Rapid Burners)

- It is very important to check that the burner flame spreader "F" and the cap "C" have been correctly positioned (see figs. 16 and 17). Failure to do so can cause serious problems.

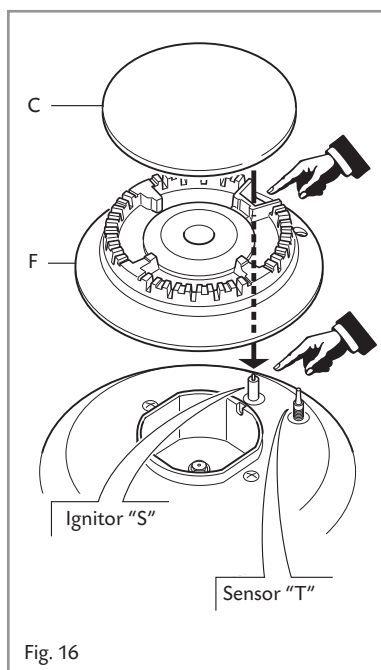

Fig. 16

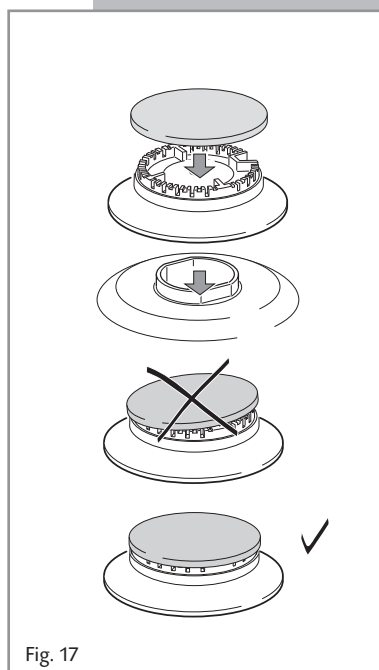

Fig. 17

Correct Position of Triple Ring Burner

The triple ring burner must be correctly positioned (see fig. 18); the burner ribs must be fitted in their housing as shown by the arrow.

The burner correctly positioned must not rotate (fig. 19).

Then position the cap "A" and the ring "B" (figs. 19 - 20)

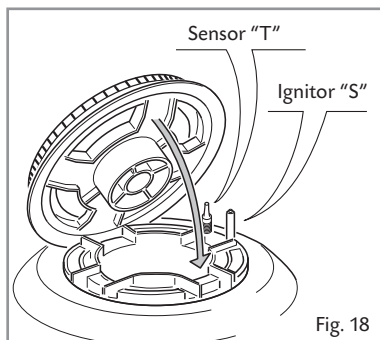

Fig. 18

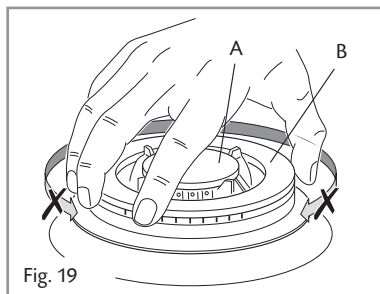

Fig. 19

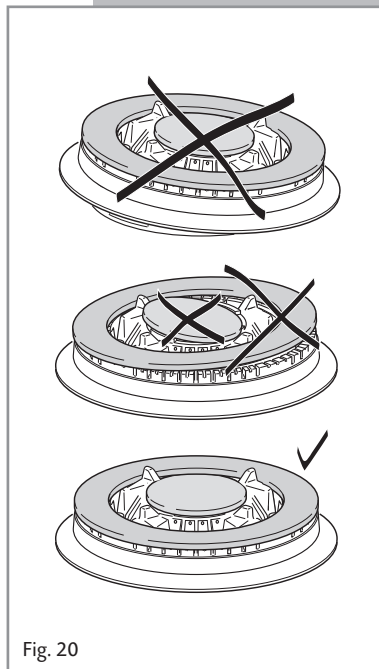
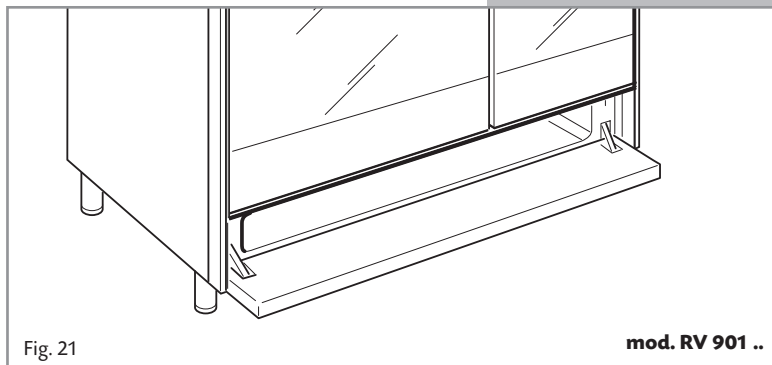

Fig. 20

Storage Compartment (Model RV 901 ..)

– The storage compartment (fig. 21) is accessible through the pivoting panel.

Attention: Do not store flammable material in the oven, or the storage compartment.



Drawer (Model RV 1001 ..)

The drawer (fig. 22) comes out like a normal drawer.

Attention: Do not store flammable material in the ovens, or the drawer.

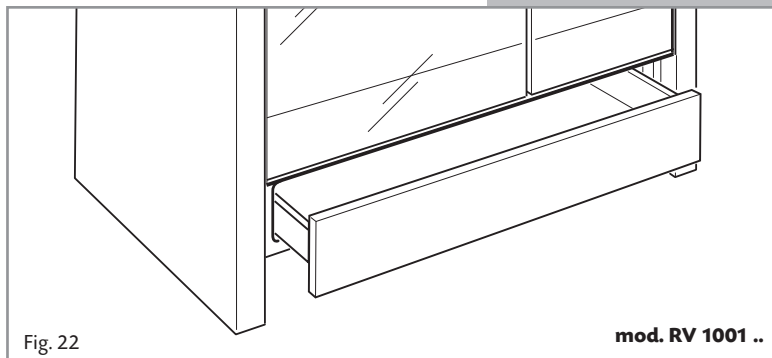

Inside of Oven

The oven should always be cleaned after use when it has cooled down.

The cavity should be cleaned using a mild detergent solution and warm water. Suitable proprietary chemical cleaners may be used after first consulting with the manufacturers recommendations and testing a small sample of the oven cavity. Abrasive cleaning agents or scouring pads/cloths should not be used on the cavity surface.

NOTE: The manufacturers of this appliance will accept no responsibility for damage caused by chemical or abrasive cleaning.

Let the oven cool down and pay special attention no to touch the hot heating elements inside the oven cavity.

Assembling and Dismantling of the Side Runner Frames

- Fit the side runner frames into the holes on the side walls inside the oven (Fig. 23).
- Slide the tray and rack into the runners (Fig. 24).
The rack must be fitted so that the safety catch, which stops it sliding out, faces the inside of the oven.
- To dismantle, operate in reverse order.

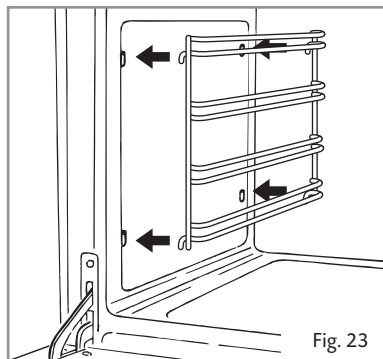

Fig. 23

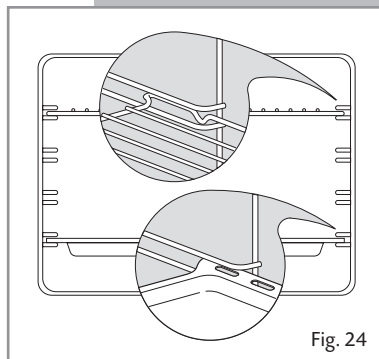

Fig. 24

Replacing the Halogen Oven Lights

WARNING: Ensure the appliance is switched off before replacing the lamp to avoid the possibility of electric shock.

- Let the oven cavity and the heating elements to cool down;
- Switch off the electrical supply;
- Remove the protective cover **C** (fig. 25);
- Replace the halogen lamp **B** with a new one suitable for high temperatures having the following specifications: 230V and same power (check watt power as stamped in the lamp itself) of the replaced lamp.

IMPORTANT WARNING: Never replace the bulb with bare hands; contamination from your fingers can cause premature failure.

Always use a clean cloth or gloves.

- Refit the protective cover;

Note: Oven bulb replacement is not covered by your guarantee.

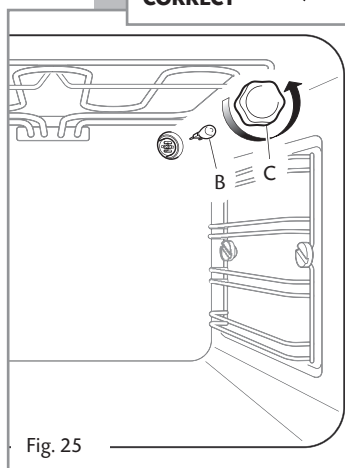
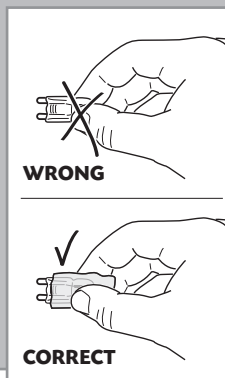

Fig. 25

Oven Doors

Removing the Oven Doors

Please operate as follows:

- Open the door completely.
- The swivel retainers of the rh and lh hinges (fig. 26a) are hooked onto the metal bar above them (fig. 26b).
- Lift the oven door slightly. The notch on the bottom of the hinge will disengage (fig. 26c).
- Now pull the oven door forwards off the appliance. Release both hinge sections from the slots (fig. 26d).

Doors Assembly

- Grip the door (as indicated in figure 26) and refit it in reverse order of removing procedure.

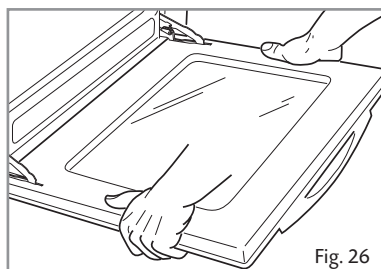
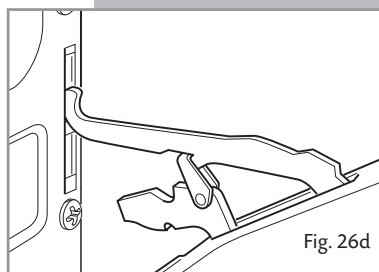
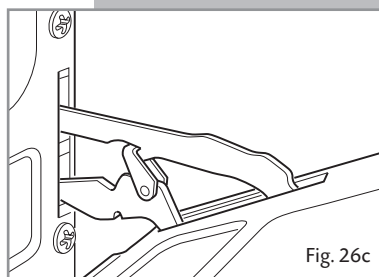
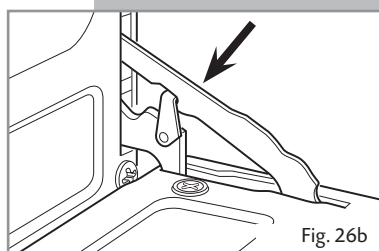
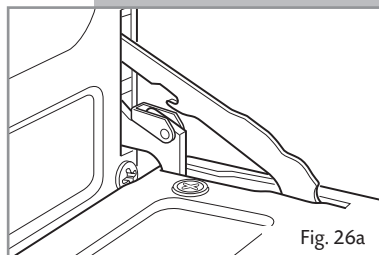

Over Doors - Cleaning The Panes Of Glass

The oven doors have two panes. To clean these, you need to remove the inner pane.

Removing the Inner Pane

- Open the door to the full extent (fig. 26a).
- Attach the swivel retainers of the rh and lh hinges onto the metal bar above them (fig. 26b).
- Gently pull out the inner pane of glass (Fig. 27a).
- Clean the glass with an appropriate cleaner.
- Dry thoroughly, and place the pane on a soft surface.
- Now you can also clean the inside of the outer glass.

Do not use harsh abrasive cleaners or sharp metal scrapers to clean the panes of glass since they can scratch the surface, which may result in shattering of the glass.

Reassembling the Inner Pane

- Check the correct positioning of the no.4 (four) silicon rubbers **D** (fig. 27b).
- Check that you are holding the pane the correct way. You should be able to read the wording on it as it faces you.
- Insert the inner pane in the left **E** and right **F** side guides (fig. 27c) and gently let it slide up to the retainers **H** (fig. 27d).
- Unlock the oven door by opening it completely and detaching the swivel retainers of the lh and rh hinges from the metal bar above them (fig. 26a).

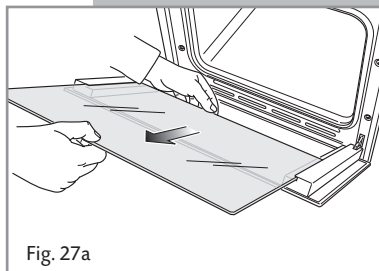

Fig. 27a

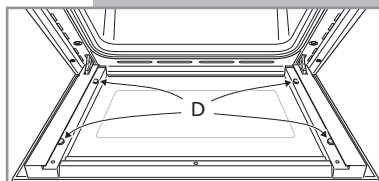

Fig. 27b

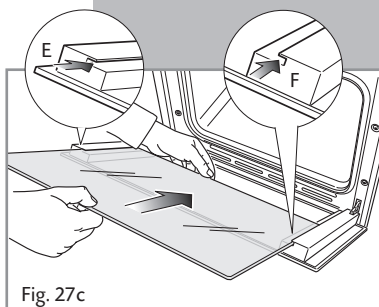

Fig. 27c

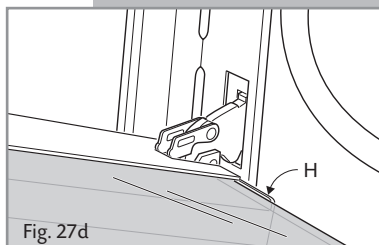
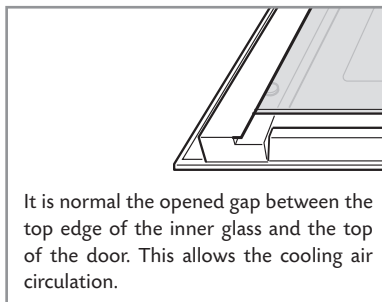

Fig. 27d

FOR THE INSTALLER

Location

This cooker has class "2/1" overheating protection so that it can be installed next to a cabinet.

The appliance may be installed in a kitchen, Kitchen/diner or a bed sitting room, but not in a room or space containing a bath or a shower.

The appliance must not be installed in a bed-sitting room of less than 20 m³.

The appliance is designed and approved for domestic use only and should not be installed in a commercial, semi commercial or communal environment.

Your product will not be guaranteed if installed in any of the above environments and could affect any third party or public liability insurances you may have.

If the cooker is installed adjacent to furniture which is higher than the gas hob cooktop, a gap of at least 200 mm must be left between the side of the cooker and the furniture.

The furniture walls adjacent to the cooker must be made of material resistant to heat.

The veneered synthetic material and the glue used must be resistant to a temperature of 90°C in order to avoid ungluing or deformations.

Curtains must not be fitted immediately behind appliance or within 500 mm of the sides.

It is essential that the cooker is positioned as stated in Figs. 28a - 28b.

The cooker must be installed by a qualified technician and in compliance with local safety standards.

If the cooker is located on a pedestal it is necessary to provide safety measures to prevent falling out.

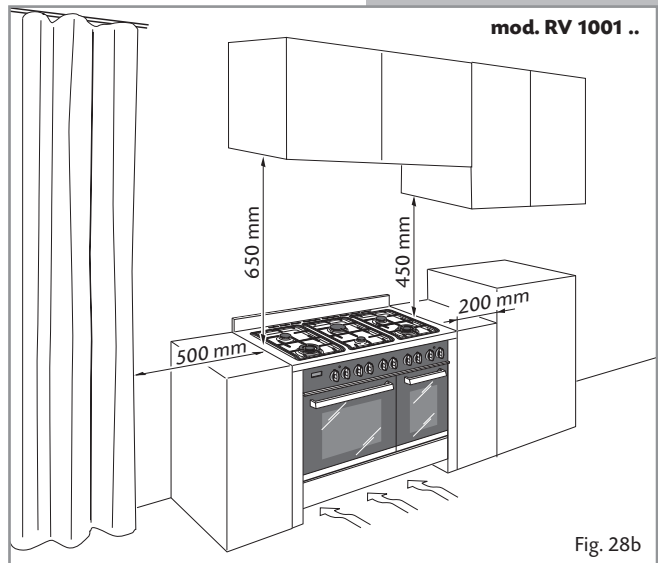
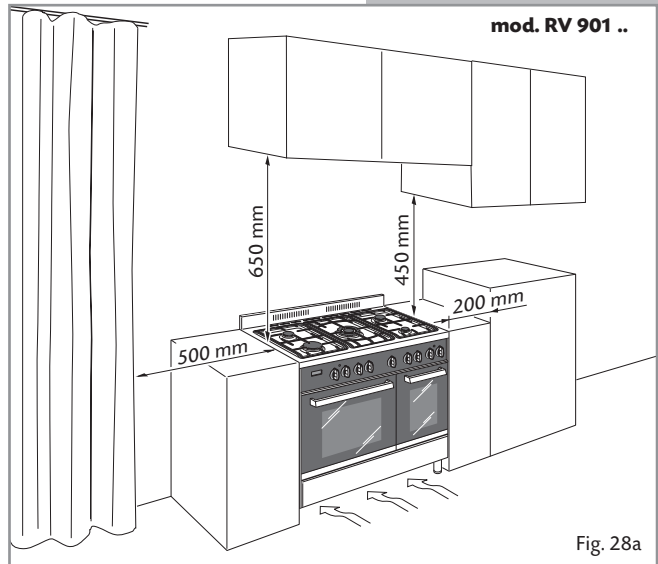

Assembling the Backguard

- Remove the two spacers "A" and the screw "B" from the rear of the cooktop.
- Assemble the backguard as shown in figure 29 and fix it by screwing the central screw "B" and the spacers "A".

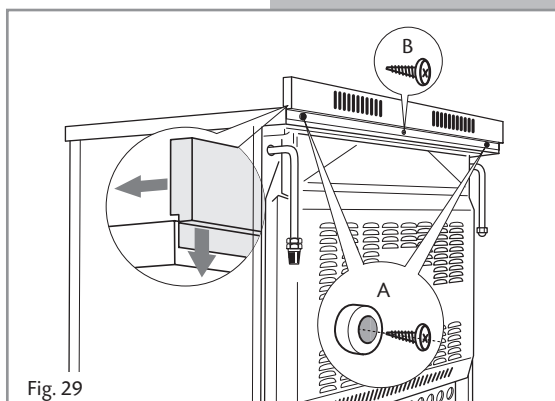

Fig. 29

Fitting the Adjustable Feet and Levelling the Cooker

mod. RV 901 ..

- The adjustable feet must be fitted to the base of the cooker before use.
- Rest the rear of the cooker on a piece of the polystyrene packaging exposing the base for the fitting of the feet.
- Fit the 4 legs by screwing them tight into the support base as shown in picture 30.

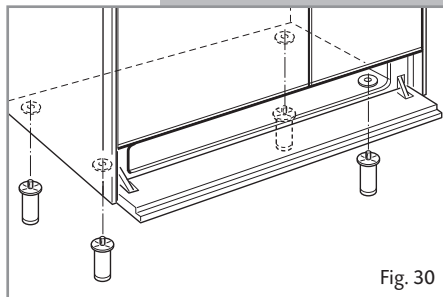

Fig. 30

Levelling the Cooker

The cooker may be levelled by screwing the lower ends of the feet IN or OUT (fig. 32).

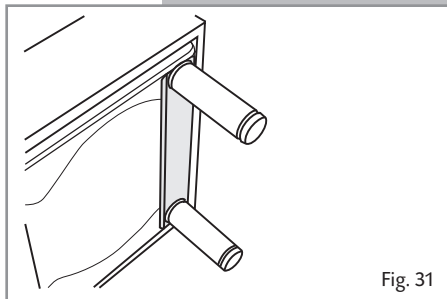

Fig. 31

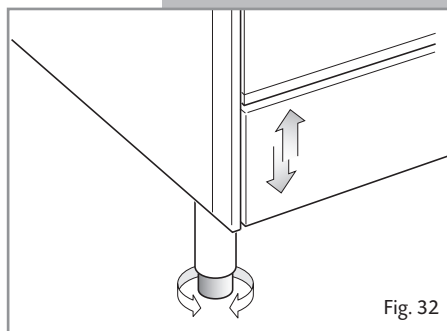

Fig. 32

Levelling the cooker

mod. RV 1001 ..

The cooker is equipped with 4 levelling feet and may be levelled by screwing or unscrewing the feet with a spanner (fig. 33).

It is important to observe the prescriptions of figures 33a - 33b.

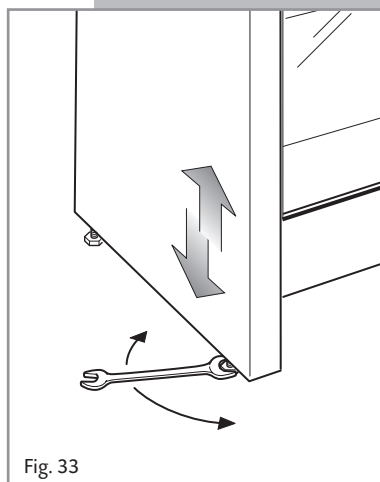
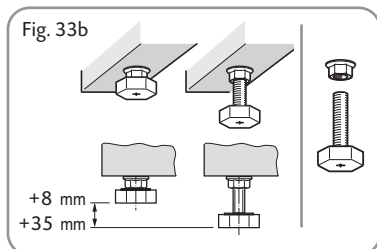
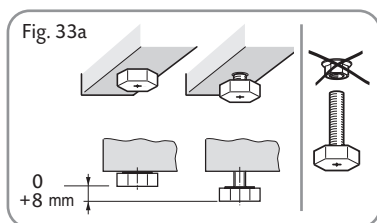

Moving the Cookers

Warning

When raising cooker to upright position always ensure two people carry out this manoeuvre to prevent damage to the adjustable feet (figs. 34a - 34b).

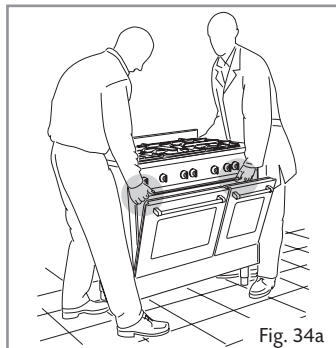

Fig. 34a

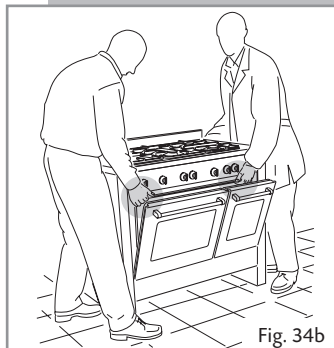

Fig. 34b

Warning

Be carefull: do not lift the cooker by the door handle when raising to the upright position (figs. 35a - 35b).

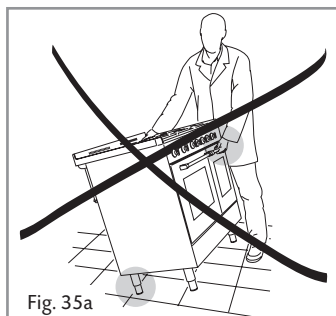

Fig. 35a

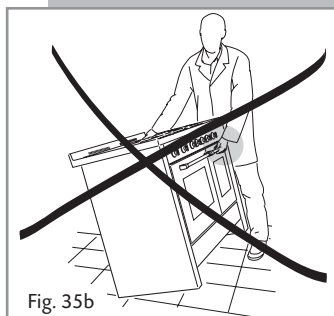

Fig. 35b

Warning

When moving cooker to its final position **DO NOT DRAG** (figs. 36a - 36b).
Lift feet clear of floor (figs. 34a - 34b).

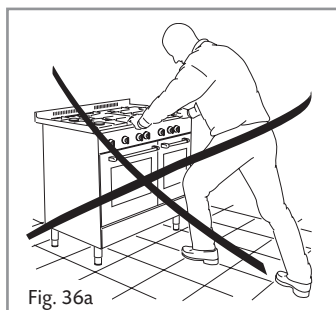

Fig. 36a



Fig. 36b

Stability Bracket

mod. RV 901 ..

We recommend a stability bracket is fitted to the cooker.

The type shown in fig. 38 can be purchased from most plumbers merchants and do it yourself (D.I.Y.) shops.

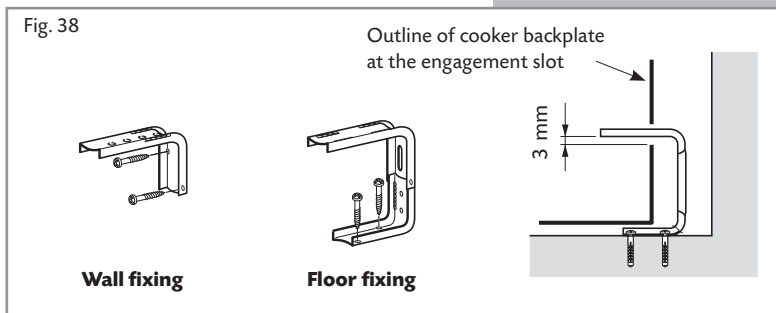
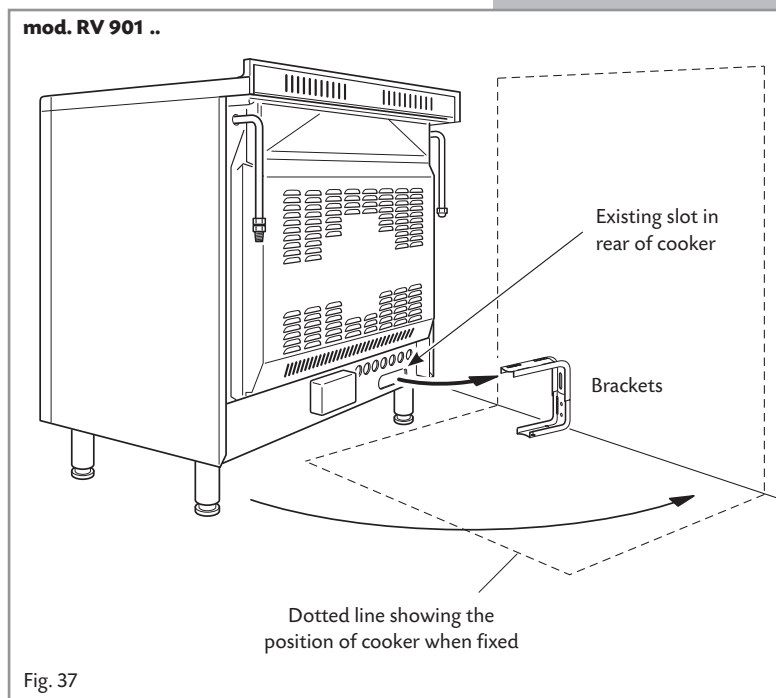

Stability Bracket

mod. RV 1001 ..

We recommend a stability bracket is fitted to the cooker.

The type shown in fig. 40 can be purchased from most plumbers merchants and do it yourself (D.I.Y.) shops.

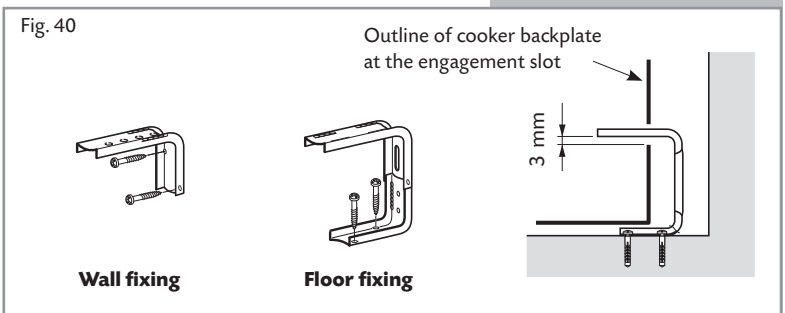
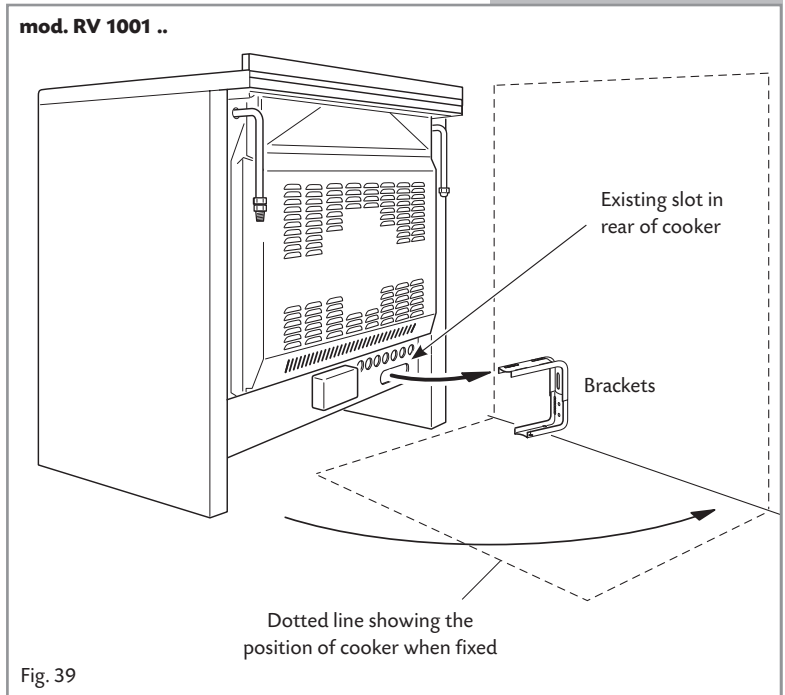

Provision for Ventilation

- The appliance should be installed into a room or space with an air supply in accordance with BS 5440-2: 2000.
- For rooms with a volume of less than 5m^3 - permanent ventilation of 100cm^2 free area will be required.
- For rooms with a volume of between 5m^3 and 10m^3 a permanent ventilation of 50cm^2 free area will be required unless the room has a door which opens directly to the outside air in which case no permanent ventilation is required.
- For rooms with a volume greater than 10m^3 - no permanent ventilation is required.

Note: Regardless of room size, all rooms containing the appliance must have direct access to the outside air via an openable window or equivalent.

- Where there are other fuel burning appliances in the same room, BS 5440-2: 2000 should be consulted to determine the correct amount of free area ventilation requirements.
- The above requirements allow also for use of a gas oven and grill but if there are other gas burning appliances in the same room, consult a qualified engineer.

Gas Installation

Important Note

This appliance is supplied for use on NATURAL GAS or LPG (check the gas regulation label attached on the appliance).

- Appliances supplied for use on NATURAL GAS: they are adjusted for this gas only and cannot be used on any other gas (LPG) without modification. The appliances are manufactured for conversion to LPG.
- Appliances supplied for use on LPG: they are adjusted for this gas only and cannot be used on any other gas (NATURAL GAS) without modification. The appliances are manufactured for conversion to NATURAL GAS.

If the NATURAL GAS/LPG conversion kit is not supplied with the appliance this kit can be purchased by contacting the After-Sales Service.

Installation and Service Regulations (United Kingdom)

It is a legal requirement that all gas appliances are Installed and Serviced by a competent person in accordance with the current editions of the following Standards and Regulations or those regulations appropriate to the geographical region in which they are to be installed:

- Gas Safety (Installation and Use) Regulations
- Building Regulations
- British Standards
- Regulations for Electrical Installation

Installation and service of any gas product must be made by a suitably qualified and registered person competent on the type of product being installed or serviced and holding a valid certificate of competence for the work being carried out. Currently the proof of competence is the Accredited Certification Scheme (ACS) or S/NVQ that has been aligned to the ACS.

It is also a requirement that all businesses or self employed installers are members of a class of person approved by the Health and Safety Executive.

Failure to install the appliance correctly could invalidate any manufacturers warranty and lead to prosecution under the above quoted regulation.

Gas Connection

The installation of the gas appliance to Natural Gas or LP Gas must be carried out by a suitably qualified and registered installer. Installers shall take due account of the provisions of the relevant British Standards Code of Practice, the Gas Safety Regulations and the Building Standards (Scotland) (Consolidation) Regulations issued by the Scottish Development Department.

Installation to Natural Gas

Installation to Natural Gas must conform to the Code of Practice, etc.

The supply pressure for Natural Gas is 20 mbar.

The installation must conform to the relevant British Standards.

Installation to LP Gas

When operating on Butane gas a supply pressure of 28-30 mbar is required. When using Propane gas a supply pressure of 37 mbar is required.

The installation must conform to the relevant British Standards.

Warning: Only a suitably qualified and registered installer, also with technical knowledge of electricity should install the appliance. He should observe the Regulations and Codes of Practice governing such installation of gas appliances.

Note: It is recommended that the gas connection to the appliance is installed with a flexible connecting tube made to BS5386.

Notes:

- **Flexible hoses can be used where the sited ambient temperature of the hose does not exceed 70°C. These hoses must be manufactured in accordance with BS669 part 1 and be of the correct construction for the type of gas being used.**
- **Gas hoses designed for natural gas MUST NOT be used for supplying LPG gas (LPG gas hoses can be identified by a either a red band or stripe on the rubber outer coating of the hose). The hose should not be crushed or trapped or be in contact with sharp or abrasive edges.**

Using a suitable leak detection fluid solution (e.g. Rocol) check each gas connection one at a time by brushing the solution over the connection.

The presence of bubbles will indicate a leak.

If there is a leak, tighten the fitting and then recheck for leaks.

IMPORTANT!

Do not use a naked flame to test for leaks.

Gas Connection

GB Cat: II 2H3+

The gas supply must use the nearest gas inlet pipe which is located at the left or the right hand side at the rear of the appliance (figs. 42a - 42b).

The hose should also be connected in such away that it does not touch the floor.

To screw the connecting tube operate with two spanners (fig. 41).

The unused end inlet pipe must be closed with the plug interposing the gasket.

After connecting to the mains, check that the coupling are correctly sealed, using soapy solution, but never a flame.

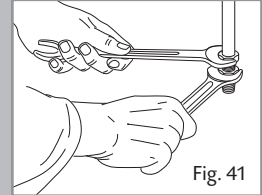

Fig. 41

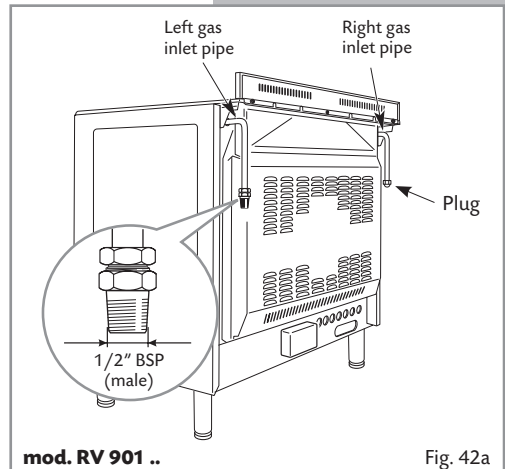

Fig. 42a

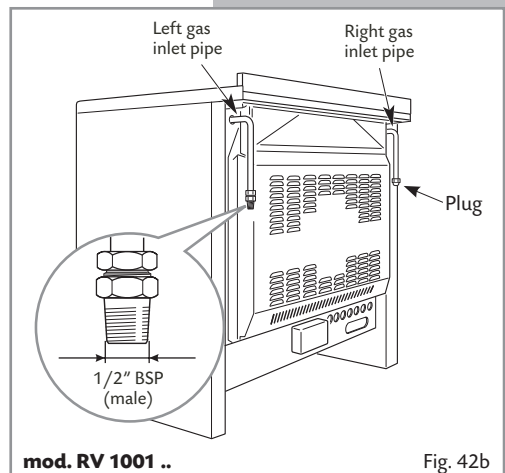
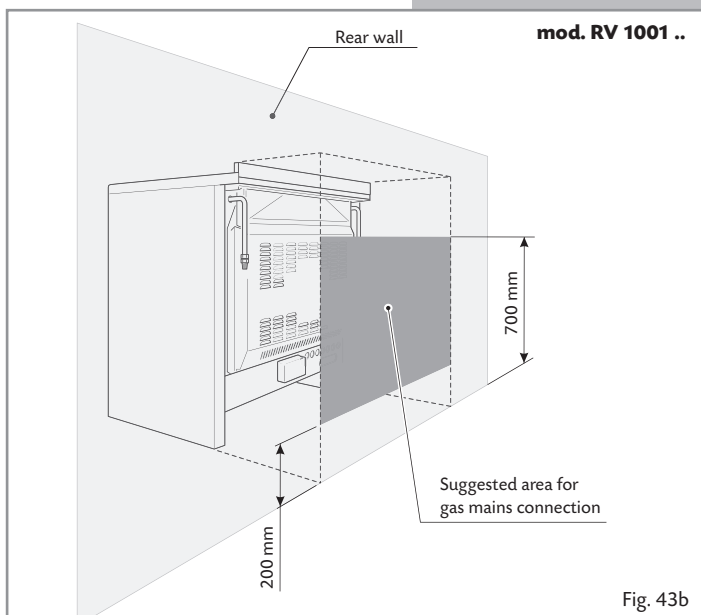
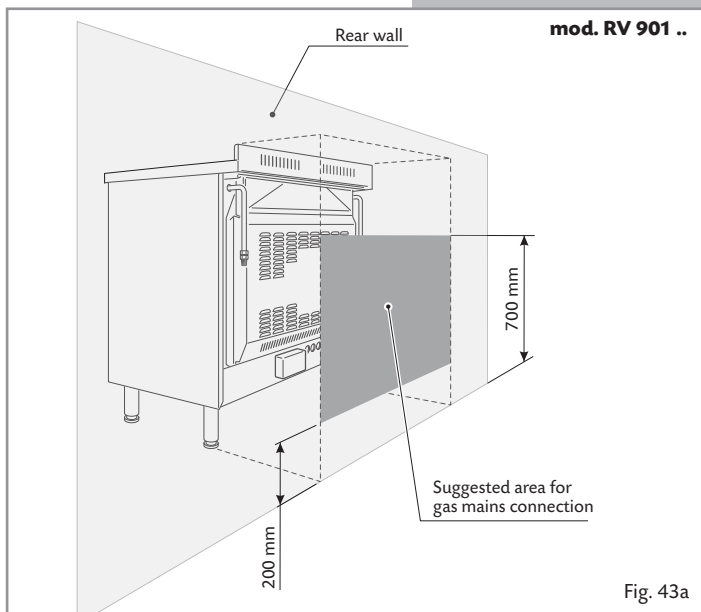

Fig. 42b

Important Prescriptions for Gas Connection



Conversion to Natural Gas or to LPG

Injectors Replacement of Top Burners

Every cooker is provided with a set of injectors for the various types of gas.

Injectors not supplied can be obtained from the After-Sales Service.

Select the injectors to be replaced according to the table at page 47.

The nozzle diameters, expressed in hundredths of a millimetre, are marked on the body of each injector.

To replace the injectors proceed as follows:

- Remove the pan supports, the burner caps and flame spreaders.
- Using a wrench, substitute the nozzle injectors "J" (figs. 44 - 45) with those most suitable for the kind of gas for which it is to be used (see "Table for the choice of the injectors").

The burners are constructed in such a way so as not to require the regulation of the primary air.

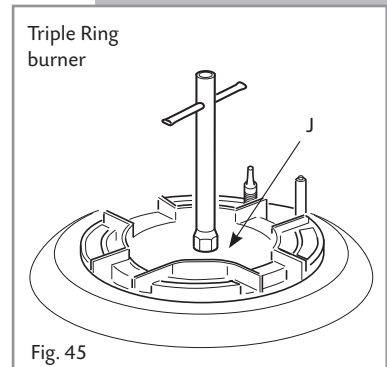
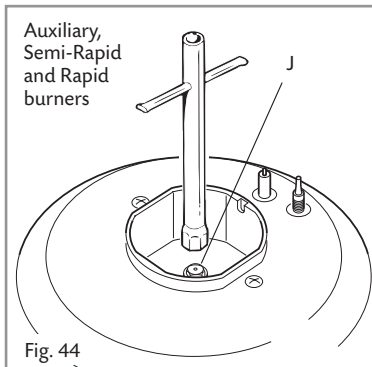

Adjusting of the Minimum of the Top Burners

Considering that in the minimum position the flame must have a length of about 4 mm and must remain lit even with a quick turn from the maximum position to that of minimum.

The flame adjustment is done in the following way:

- Turn on the burner
- Turn the tap to the MINIMUM position
- Take off the knob
- With a thin screwdriver turn the screw "F" until adjustment is correct (fig. 46).

Normally for LPG, tighten up the regulation screw.

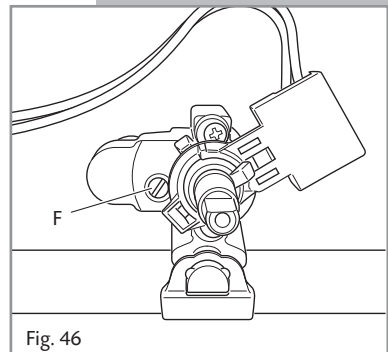

Table for the Choice of the Injectors**GB Cat: II 2H3+**

Burners	Nominal Power kW	Reduced Power kW	G30 - 28-30 mbar G31 - 37 mbar	G20 - 20 mbar
			Ø Injector 1/100 mm	Ø Injector 1/100 mm
Auxiliary (A)	1,00	0,30	50	72 (X)
Semi-Rapid (SR)	1,75	0,45	65	97 (Z)
Rapid (R)	3,00	0,75	85	115 (Y)
Triple Ring (TR)	3,50	1,50	95	135 (T)

Increase of Air Necessary for Gas Combustion (2 m³/h x kW)

Burners	Air necessary for combustion (m ³ /h)
Auxiliary (A)	2,00
Semi-Rapid (SR)	3,50
Rapid (R)	6,00
Triple Ring (TR)	7,00

Lubrication of the Gas Taps

The operations must be executed by a qualified technician.

IMPORTANT: All intervention regarding installation maintenance and conversion of the appliance must be fulfilled with original factory parts.

The manufacturer declines any liability resulting from the non-compliance of this obligation.

Electrical Installation

**WARNING! Electricity can be extremely dangerous.
This appliance must be earthed.**

The appliance must be connected to the electrical network verifying above all that the voltage corresponds to the value indicated on the specifications plate and that the cables section of the electrical plant can bear the load which is also indicated on the plate.

It is recommended that the appliance is connected directly to the mains by fixed wiring, placing a double pole switch with minimum opening between the contacts of 3 mm.

The power supply cable must not touch the hot parts and must be positioned so that it does not exceed 75°C at any point.

Once the cooker has been installed, the switch must always be accessible.

Before effecting any intervention on the electrical parts the appliance must be disconnected from the network.

Electrical Feeder Cable Connection

To connect the feeder cable to the cooker it is necessary to:

- Remove the screw that hold shield "A" behind the cooker (fig. 48).
- Insert the feeder cable of the suitable section (as described in the next chapter) into the cable clamp "D".
- Connect the phase and earth cables to the terminal block "B" according to the diagram in figure 47.
- Pull the feeder cable and block it with cable clamp "D".
- Re-mount shield "A".

Feeder Cable Section

Type H05RRF

230 V~ 3 x 2.5 mm² (**)

(**) - Connection with wall box connection.

Earth cable must be 2 cm longer than neutral and live cables.

230 V ~

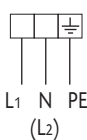

Fig. 47

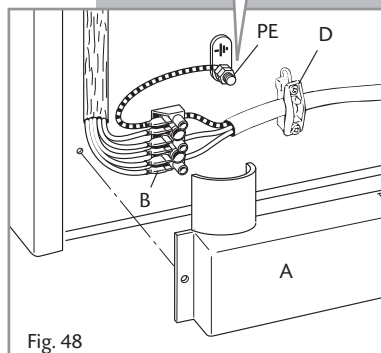
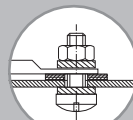

Fig. 48

Connection to Fixed Wiring

A double pole switch must be provided no further than 2 metres from the appliance to the electrical supply.

The appliance should be connected to a DOUBLE POLE SWITCHED FUSED SPUR OUTLET, similar to that shown in Fig. 49.

We recommend that the appliance is connected by a suitably qualified person who will comply with the IEE and local regulation.

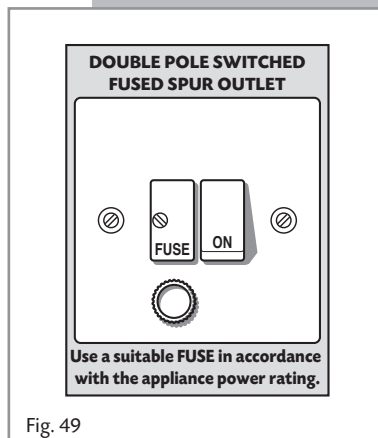

Fig. 49

Appliance Servicing

CDA provide a quality and effective after-sales service to cover all your servicing needs.

Please attach your receipt to this page for safekeeping.

Please help us to help you by having the following information available when booking a service-call:

1. Model type, make and model – see the product data plate.
2. Evidence of installation / purchase date.
3. Retailer where appliance was purchased.
4. Clear and concise details of the fault.
5. Full address including postcode and any contact phone numbers.

Contact telephone numbers

CDA Customer Care Department

– Telephone: 01949 862012

– Fax: 01949 862003

– Email: service@cda.eu

Guarantee

CDA appliances carry a five-year parts and a one-year labour guarantee.

CDA will repair or replace any defect or part attributable to faulty material or workmanship. Within the first year this will be free of both labour and parts charges. After the first year and within five years, the parts will be supplied free of charge provided that the repair is carried out by an agent authorised by CDA and the labour will be charged at the commercial rate applicable at the time of repair.

The appliance must have been installed by a suitably qualified person and in accordance with the manufacturer's instructions and current legislation. The guarantee does not cover faults caused by the incorrect fitting of appliances.

Limit of Cover

- The guarantee does not cover cosmetic damage e.g. discolouration or oxidation.
- Proof of purchase or installation date must be produced before a service-call will be booked.
- The appliance must be used for domestic purposes only. Appliances used for commercial or professional purposes are not covered by the guarantee. Commercial warranty is available at extra cost.
- The appliance must not be modified or tampered with or repair attempted by any unauthorised person.
- The guarantee does not cover damage caused in transit or by misuse, accident, abuse or neglect.
- The guarantee does not cover routine maintenance.
- Use of parts not supplied or recommended by |C|D|A| will invalidate the warranty.
- Rubber seals, filters, removable glass parts, control knobs and buttons, fuses and light bulbs will need replacing periodically and are not covered by the guarantee.
- Second-hand or reconditioned appliances are not covered by the guarantee.

The conditions under which this guarantee is offered are in addition to the statutory rights of the domestic purchaser and these statutory rights are not affected by this guarantee.

CDA reserve the right to change specification without prior notice.



To contact our Customer Care Department, or for Service,
please contact us on the details below.

Free Manuals Download Website

<http://myh66.com>

<http://usermanuals.us>

<http://www.somanuals.com>

<http://www.4manuals.cc>

<http://www.manual-lib.com>

<http://www.404manual.com>

<http://www.luxmanual.com>

<http://aubethermostatmanual.com>

Golf course search by state

<http://golfingnear.com>

Email search by domain

<http://emailbydomain.com>

Auto manuals search

<http://auto.somanuals.com>

TV manuals search

<http://tv.somanuals.com>