

Cateye Cyclosimulator

**MODEL CS-1000
SERVICE MANUAL**

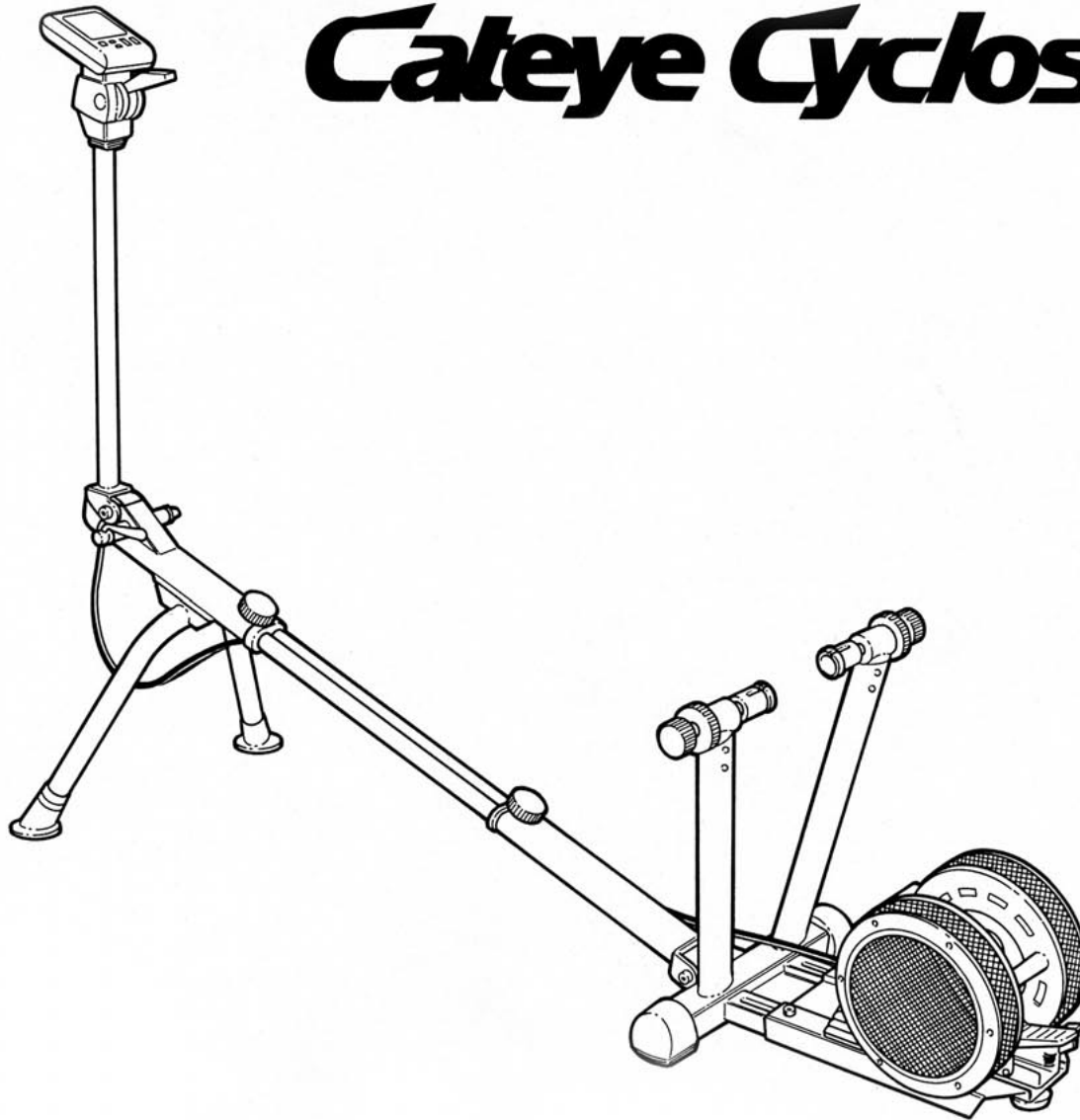

CATEYE CO., LTD.

CS-SEM: 891124

INDEX

INTRODUCTION

- How to use the service manual
- PNE-1: Parts Identification
- PNE-2: Wiring Diagram

Part A

- * Trouble shooting

Part B

- S-1 : Replacing control unit
- S-2 : Replacing grade shift lever
- S-3 : Replacing copper disc
- S-4 : Replacing magnet
- S-5 : Replacing magnet mounting base
- S-6 : Replacing roller revolution sensor
- S-7 : Replacing grade shift lever unit
- S-8 : Replacing workload unit
- S-9 : Replacing clamp cone
- S-10 : Replacing clamp bolt
- S-11 : Replacing inner tube
- S-12 : Replacing fan case
- S-13 : Replacing magnet case
- S-14 : Adjustment of control wire
- S-15 : Adjustment of cord length at roller revolution sensor

Part C

- PLE: Parts list

HOW TO USE THE SERVICE MANUAL

HOW TO USE THE SERVICE MANUAL

This service manual consists of Part A, B, and C. Part A relates to trouble shooting with probable cause and remedy. Part B describes detailed repair work and adjustment in various sections. Part C covers the parts necessary for the repair work, with the corresponding parts numbers.

Whenever any problem is encountered with CS-1000 product, the following sequence will be the tips to correct the condition.

1. Find the probable cause of problem with Part A.
2. Identify parts names with PNE-1 in this manual.
3. Follow Part B for repair work or adjustment required.
4. In case replacement part is required, use Cateye genuine parts listed in Part C.

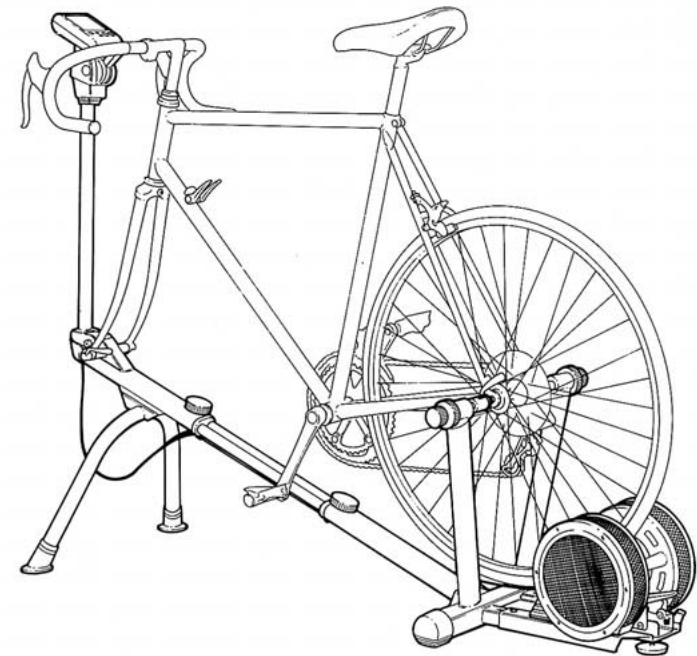

PARTS IDENTIFICATION

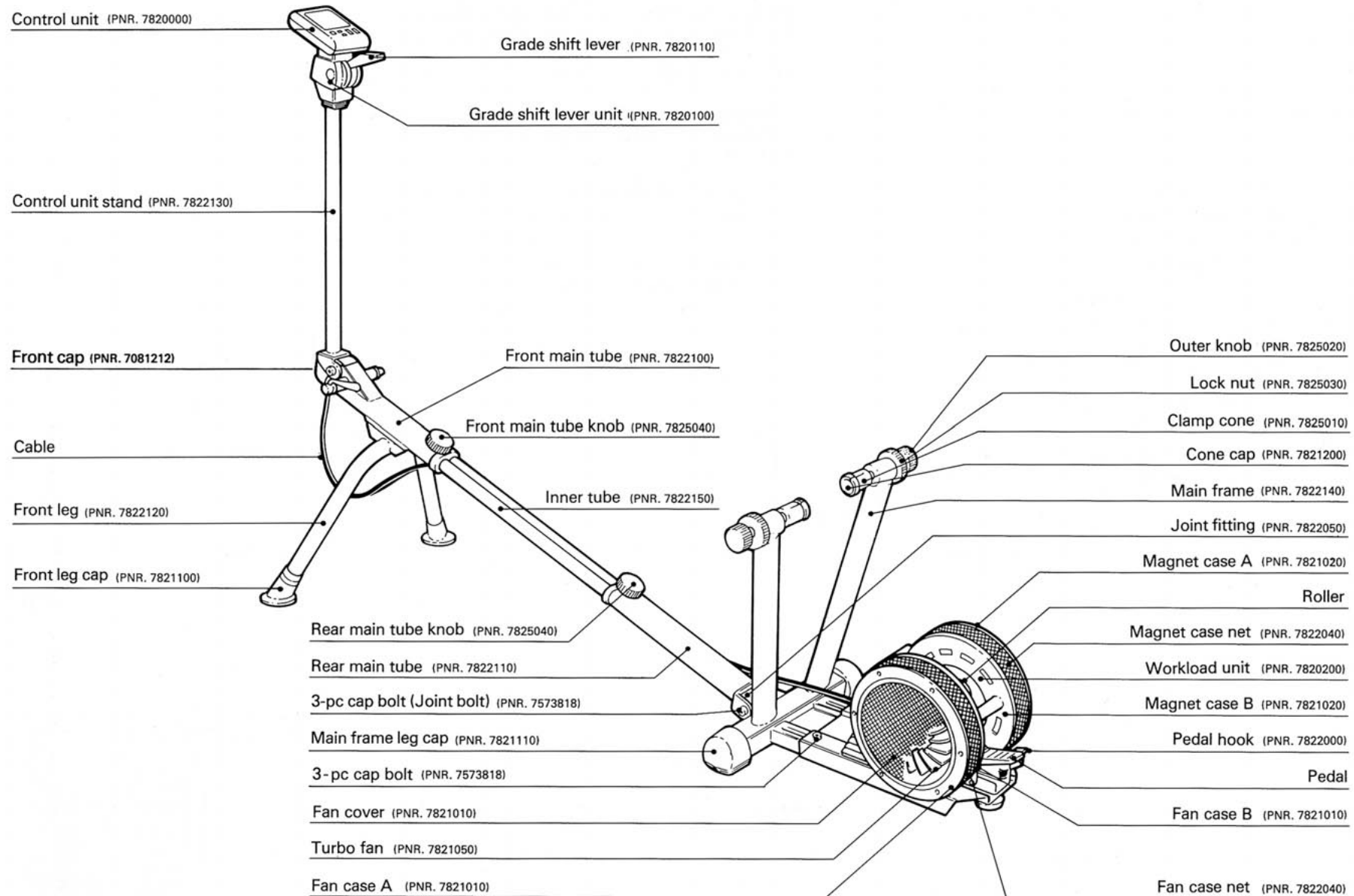

CS-1000 WIRING DIAGRAM

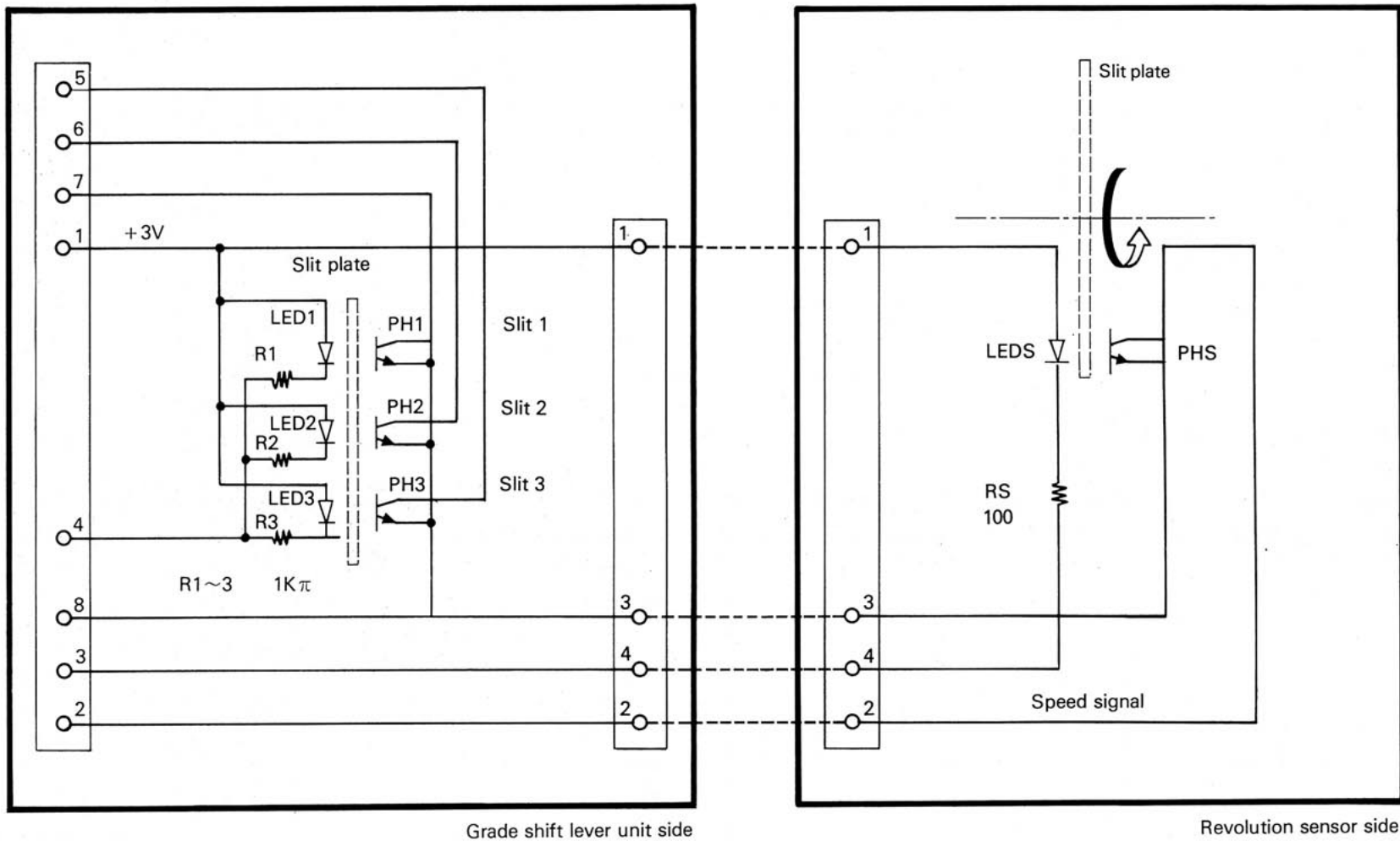

CATEYE CYCLOSIMULATOR MODEL CS-1000 SERVICE MANUAL

Part A

CS-SME-PA1: 891124

| Problems | Probable cause | Check method | Remedy |
|--|--|---|---|
| Displays for current speed, trip distance, work rate, calorie consumption remain all "0", and do not change. | 1. Faulty or poor connection of cord connector inside magnet case: | Remove magnet case A and net, and check if cord connection at the sensor is correct and positive. See S-6: Fig.22. | Re-fix the cord following "S-15: Adjustment of Cord Length at Roller Revolution Sensor", and connect the cord connector securely in position. |
| | 2. Revolution sensor inside magnet case is defective: | Replace sensor with new one, and see if display works properly. | Replace sensor with new one following "S-6: Replacing Roller Revolution Sensor". |
| | 3. Poor connection of cord connector inside control unit: | Take out control unit from grade shift lever unit, and see if connector is positively connected with control unit. See S-1: Fig.4. | Connect cord connector positively into position following "S-1: Replacing Control Unit". |
| | 4. Defective control unit: | Replace control unit with new one, and see if display works. If it does, the control unit was defective. | Replace control unit with new one following "S-1: Replacing Control Unit". |
| | 5. Breakdown of wire in cords: | Replace grade shift lever unit with new one, and see if display works. | Replace grade shift unit with new one, following "S-7: Replacing Grade Shift Lever Unit." |
| Percent grade does not appear on control unit screen. | 1. Defective control unit: | Replacing control unit with new one, see if display works. | Replace control unit with new one following "S-1: Replacing Control Unit". |
| Abnormal displays appear on control unit screen. | 1. "All Clear" operation has been overlooked: | Effect "All Clear" operation by depressing AC button on the back of control unit (See P.7, Operating Instruction), and see if the condition is corrected. | If corrected, the unit is under the normal condition. |
| | 2. Defective control unit: | Replace control unit with new one, and see if the condition is corrected. | If corrected, replace control unit with new one following "S-1: Replacing Control Unit". |
| Nothing appears on control unit screen. | 1. Electric cells have run out. | Replace cells with new ones and see if the condition is corrected. | Replace cells with new ones following "P-7, Operating Instruction". |
| | 2. Defective control unit: | Replace control unit with new one and see if displays are normal. | Replace control unit with new one following "S-1: Replacing Control Unit". |

CATEYE CYCLOSIMULATOR MODEL CS-1000 SERVICE MANUAL

Part A

CS-SME-PA2: 891124

| Problems | Probable cause | Check method | Remedy |
|---|--|---|--|
| Control unit case is broken. | | | Replace control unit with new one following "S-1: Replacing Control Unit". |
| Grade shift lever cannot be set at 10%, or tends to return to 7%. | 1. Control wire is twisted: | Check and see if control wire and cord are twisted at main tube. | Take off workload unit from main frame, and correct the condition. |
| | 2. Maladjustment of control wire inside magnet case: | Remove magnet case A. Moving grade shift lever, see if arm of magnet mounting base comes in contact with adjust boss before the lever reaches grade 10%. See S-5: Fig.21-B. | Re-adjust control wire following "S-14: Adjustment of Control Wire". |
| | 3. Defective parts inside grade shift lever: | Replace grade shift lever with new one, and see if condition is corrected. | Replace grade shift lever with new one following "S-2: Replacing Grade Shift Lever". |
| Heavy drag on grade shift lever. | 1. Breakdown of control wire: | Visually check through condition of control wire. | Replace grade shift lever unit with new one following "S-7: Replacing Grade Shift Lever Unit". |
| | 2. Defective parts in grade shift lever: | Replace grade shift lever with new one, and see if lever travels smoothly. | Replace grade shift lever with new one following "S-2: Replacing Grade Shift Lever". |
| Grade shift lever is broken. | | | Replace grade shift lever with new one following "S-2: Replacing Grade Shift Lever". |

CATEYE CYCLOSIMULATOR MODEL CS-1000 SERVICE MANUAL

Part A

CS-SME-PA3: 891124

| Problems | Probable cause | Check method | Remedy |
|--|---|--|--|
| Abnormal noise at workload unit on operation | 1. Foreign matters in between workload unit frame and roller: | Visually check if any foreign matter exists therein. | Remove the foreign matters. |
| | 2. Magnet may be broken inside magnet case: | Remove magnet case A and net, and see if the magnet is broken. See S-4: Fig.16. | Replace magnet with new one following "S-4: Replacing Magnet". If marked deformation is observed on copper disc, also replace copper disc with new one following "S-3: Replacing Copper Disc". |
| | 3. Magnet is in contact with copper disc: | Remove magnet case A and net, and see if magnet contacts with copper disc. See S-4: Fig.16. | Adjust magnet position following "S-4: Replacing Magnet". |
| | 4. Loose cord connector is in contact with copper disc inside magnet case: | Remove magnet case A and net, and see if cord connector is positively connected in position. Refer to S-1: Fig.4. | Re-fix the cord following "S-15: Adjustment of Cord Length at Roller Revolution Sensor", and set the cord connector securely in position. |
| | 5. Malfunction of workload unit, i.e. defective roller bearing: | If the noise still exists after following steps 1 to 4 above, workload unit itself is considered as defective. | Replace workload unit following "S-8: Replacing Workload Unit". |
| Mechanism locked, or less drag (slippage) on operation. | 1. Releasing roller lock was overlooked: | Check if pedal is locked by pedal hook. | Release locking mechanism by depressing the pedal. |
| | 2. Workload unit is not in the correct position: | Rotating the pedal, see if tire slips against roller. | Re-adjust position of workload unit following instructions in section "How To Mount Your Bike", on page 6 of Operating Instruction. |
| Load is actually felt less than indications on display screen. | 1. Control wire may be twisted or distorted, causing improper conversion of the load: | Check and see if control wire and cord are twisted at main tube. | Take out workload unit from main frame, and eliminate distortion of control wire and cord. |
| | 2. Maladjustment of control wire in magnet case: | Remove magnet case A. Moving grade shift lever towards 10%, see if the clearance between magnet mounting base arm and adjust boss does not exceed abt. 2 mm. (Standard: 0-1 mm) Excess clearance may cause the problem. | Re-adjust control wire following "S-14: Adjustment of Control Wire". |



CATEYE CYCLOSIMULATOR MODEL CS-1000 SERVICE MANUAL

Part A

SC-SME-PA4: 891124

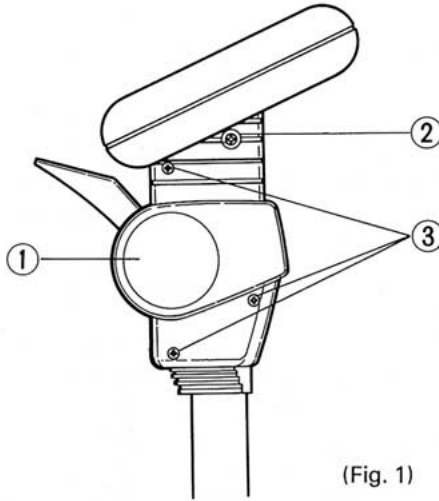
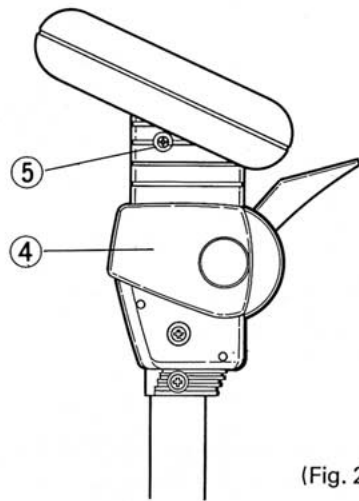
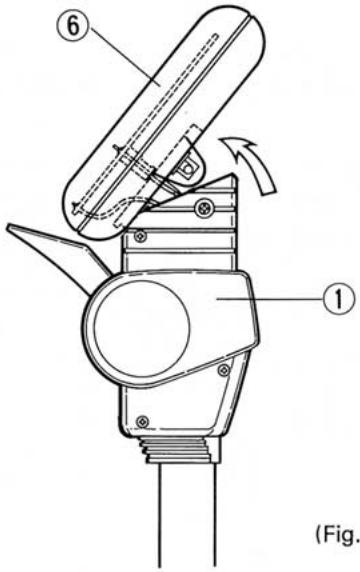
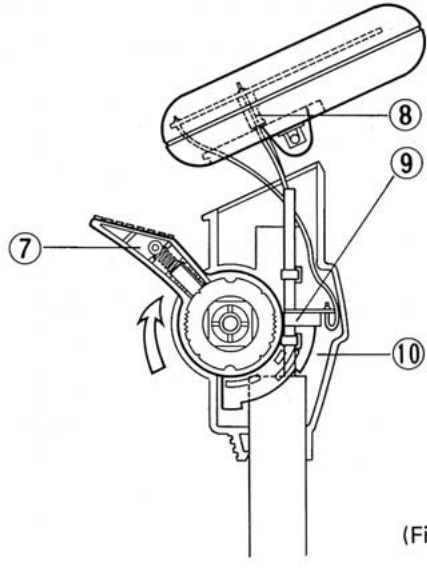
| Problems | Probable cause | Check method | Remedy |
|--|---|--|--|
| Load does not actually change by moving grade shift lever. | 1. Control wire may be broken: | Check through and see if control wire is broken. | Minor deformation of wire can be manually corrected. If deformation is beyond manual handling, replace grade shift lever unit with new one, following "S-7: Replacing Grade Shift Lever Unit". |
| | 2. Improper fixing of outer wire clamp inside magnet case: | Remove magnet case A, and see if outer wire setting screw area is properly fixed in horizontal position. | Loosen hexagonal lock nut for fixing outer wire set screw, re-adjust it into correct horizontal position, and tighten the lock nut. |
| Magnet case or fan case is broken. | | | Replace magnet case, or fan case, with new one, following "S-13: Replacing Magnet Case", or "S-12: Replacing Fan Case". |
| Workload unit does not slide on main frame smoothly. | 1. Dimensional tolerances of sliding bearing surface on workload unit may be out of standard: | Sliding workload unit on main frame, check if its movement is smooth. | If the problem is within the minor degree, lubricate bearing surface and see how it works. If not, replace workload unit with new one following "S-8: Replacing Workload Unit". |
| Rear wheel axle of bike does not snug fit to clamp cone of main frame. | 1. Diameter of rear wheel axle is smaller than the acceptable tolerance of clamp cones: | Fully tighten outer knobs, and see if clearance exists between wheel axle and clamp cones. | Replace clamp bolt with that of longer type (optional item) following "S-10: Replacing Clamp Bolt". |
| | 2. Shape of quick release on rear wheel axle does not fit to clamp cones: | Quick release does not fit to clamp cones, or tends to come out of position in exercise. | Try to use quick release of different type, or prepare clamp cones of special type. Refer to "S-9: Replacing Clamp Cone". |
| Inner tube is bent. | | | Replace inner tube with new one following "S-11: Replacing Inner Tube". |

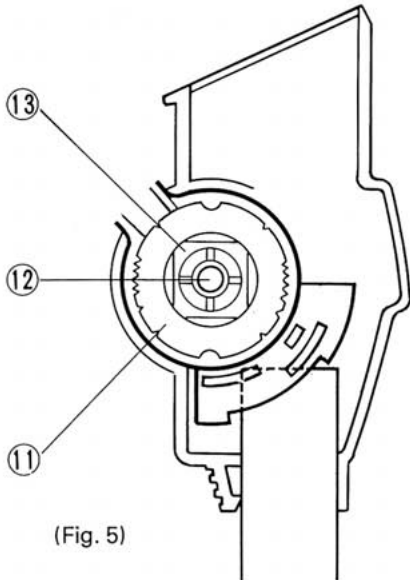
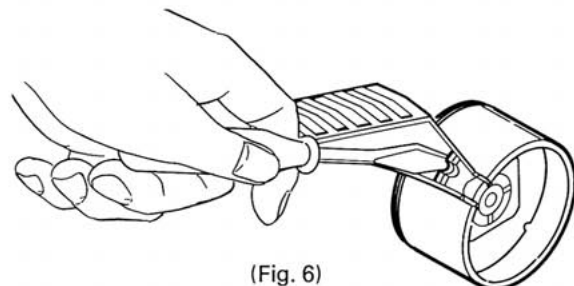
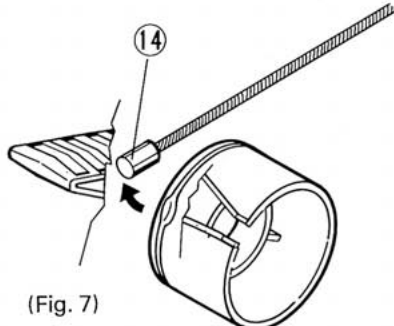
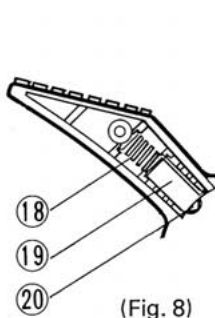
| No. | Replacing Control Unit | EXPLANATION | |
|-----|---|--|--|
| S-1 | <p>(1) Remove 4 set screws (2, and 3) on right side plastic cover (1) of grade shift lever unit, with screw driver. (Fig. 1)</p> <p>(2) Remove screw (5) from left side plastic cover (4). (Fig. 2)</p> <p>(3) Control unit (6) is connected with inside plastic cover with a cord, so carefully remove the unit from plastic cover, by rotating it in the arrow direction around the hook portion of plastic cover, as shown in Fig. 3. Avoid rough handling.</p> <p>(4) Take off right side plastic cover (1). (Fig. 3)</p> <p>(5) Moving grade shift lever (7) until slit plate (8) comes apart from base block (9), and remove the base block by sliding it off along the guide rib of left plastic cover. (Fig. 4)</p> <p>(6) Detach cord connector (10) from the back of control unit. (Fig. 4)</p> <p>(7) Disassembling of control unit is completed with the foregoing steps. For assembling, follow the steps in the reverse way. For step 5 in the course of assembling, slide in base block along the guide rib of plastic cover to the full. Moving the grade shift lever, carefully place slit plate in the slot of base block, to avoid damage on base block.</p> |  <p>(Fig. 1)</p> |  <p>(Fig. 2)</p>  <p>(Fig. 3)</p>  <p>(Fig. 4)</p> |

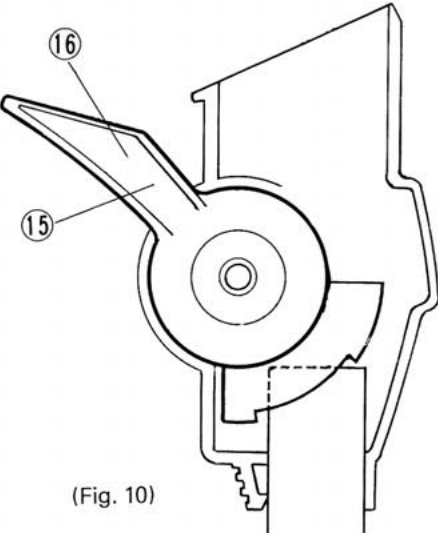
| No. | Replacing Grade Shift Lever | EXPLANATION |
|-----|--|---|
| S-2 | <p>(1) Take out control unit and right side plastic cover of grade shift lever unit. (Refer to S - 1: Replacing Control Unit.)</p> <p>(2) Remove screw (12) and plastic washer (13) setting ratchet discs (11). (Fig. 5)</p> <p>(3) Using a minus (-) screw driver from the side, take out ratchet discs one by one. (Fig. 6)</p> <p>* Ratchet discs are lightly pressed in with the square key hole at the center.</p> <p>(4) Take out grade shift lever, and disengage control wire end (14) from the lever. (Fig. 7)</p> <p>Note: Be sure to keep control wire end outside the tube.</p> <p>(5) Engage control wire end to the new grade shift lever, and assemble the lever to the plastic cover.</p> <p>(6) Place ratchet discs in the correct position, and secure them with a plastic washer and set screw.</p> <p>(7) Insert spring (18), pawl (19) and pawl guide (20) in the lever. Place cushion (17) at the spring, and set cover of lever (15) with screw (16). (Fig. 8, 9 and 10)</p> <p>(8) Assemble right side plastic cover of grade shift lever unit and control unit. (Refer to S - 1: Replacing Control Unit.)</p> |  <p>(Fig. 5)</p>  <p>(Fig. 6)</p>  <p>(Fig. 7)</p>  <p>(Fig. 8)</p>  <p>(Fig. 9)</p>  <p>(Fig. 10)</p> |

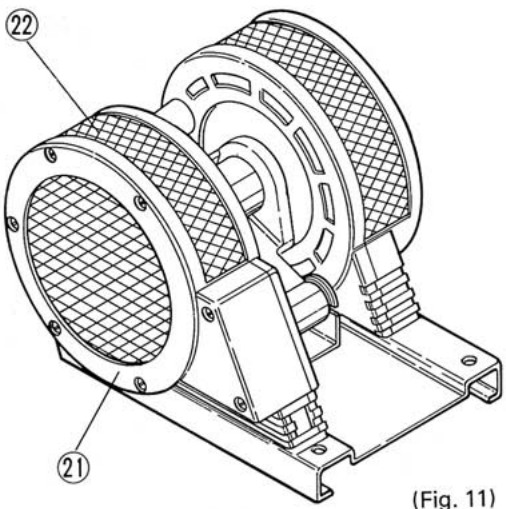
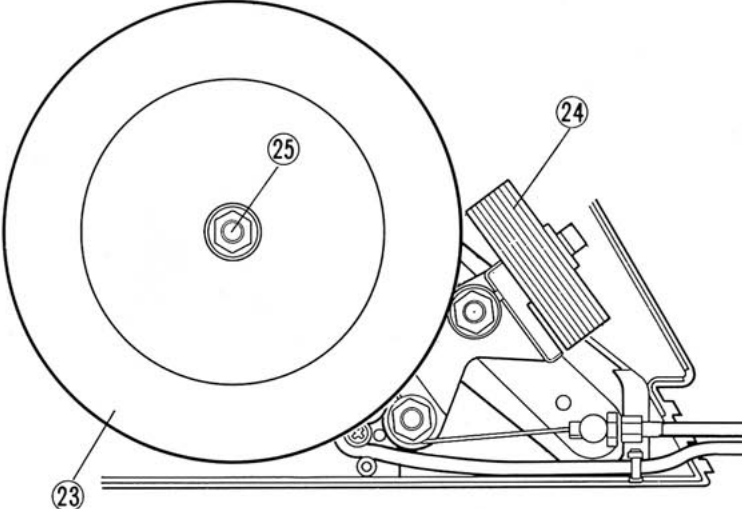
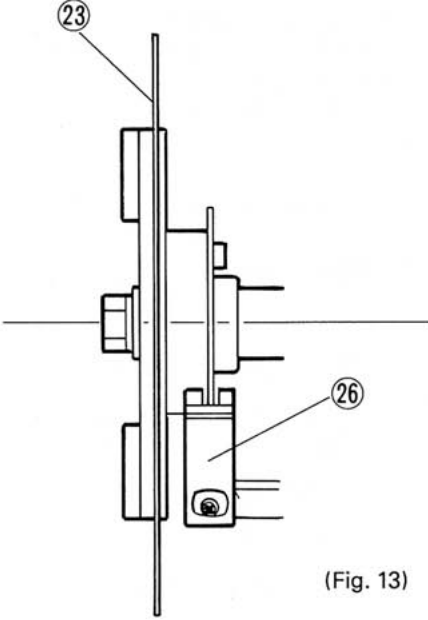
| No. | Replacing Copper Disc | EXPLANATION |
|-----|---|---|
| S-3 | <p>(1) Using a screw driver, loosen tapping screws setting magnet case A (21) to workload unit, and take off magnet case A and magnet case net (22). (Fig. 11)</p> <p>* Pay attention on sharp edges of the net for finger injury.</p> <p>(2) Lift grade shift lever to its top position to grade 0%, and keep magnet (24) apart from copper disc (23). (Fig. 12)</p> <p>(3) Using spanner (B-13) or monkey wrench, loosen hexagonal nut (25) setting the copper disc. Remove fan cover on the other side and hold turbo fan or flywheel by hand for easy access.</p> <p>(4) Remove set screw of roller revolution sensor (26) with screw driver. (Fig. 13)</p> <p>(5) Take out copper disc with flat washer and spring washer from spindle.</p> <p>(6) Assemble new copper disc in the reverse way as described.</p> |  <p>(Fig. 11)</p>  <p>(Fig. 12)</p>  <p>(Fig. 13)</p> |

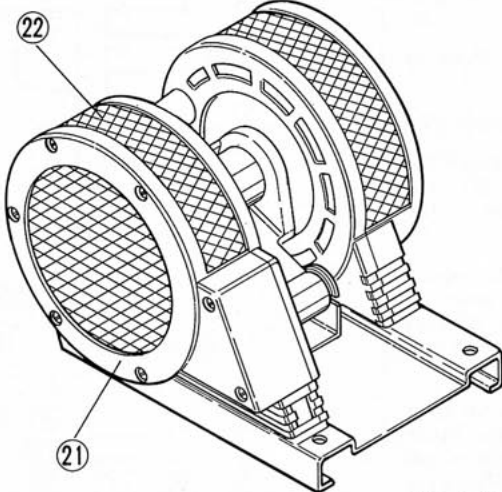
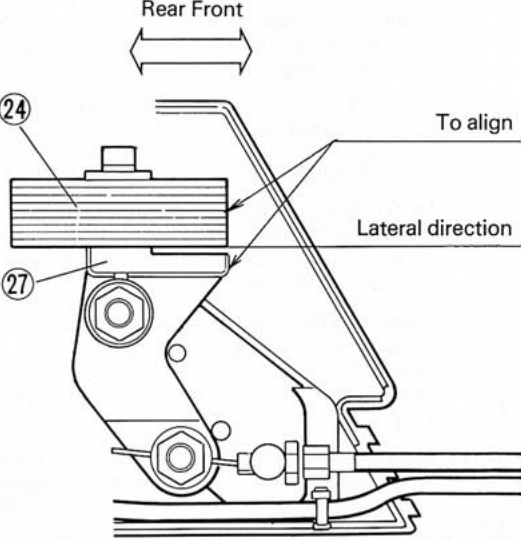
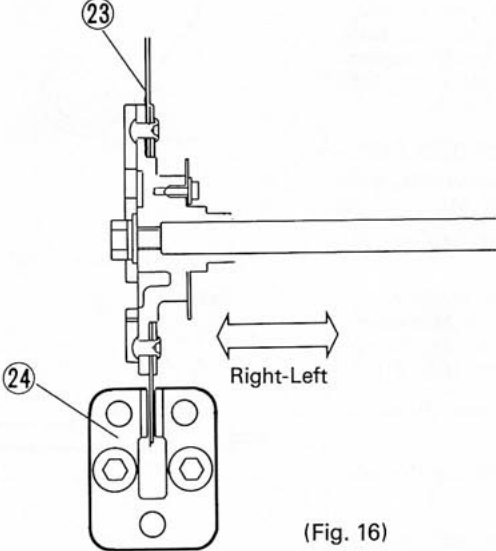
| No. | Replacing Magnet | EXPLANATION |
|-----|--|---|
| S-4 | <p>(1) Using a screw driver, loosen tapping screws on magnet case A (21), and remove magnet case A and magnet case net (22) from workload unit. (Fig. 14)</p> <p>* Pay attention on sharp edges of the net for finger injury.</p> <p>(2) Move down grade shift lever to its lowest position to grade 10% and keep magnet mounting base (27) in horizontal position. (Fig. 15)</p> <p>(3) Remove cap bolt setting magnet (24) with hexagonal L-shape wrench, and take out magnet, spring washer and flat washer from magnet mounting base.</p> <p>(4) Place new magnet on mounting base, and set it in position temporarily with cap bolt, spring washer and flat washer, allowing movement of magnet for adjustment.</p> <p>(5) Determine the correct position of magnet in the following way and secure it by tightening cap bolt with hexagonal L-wrench.</p> <p>* Rear edge of magnet must vertically align with that of mount base. (Fig. 15)</p> <p>* Copper disc clearance to magnet must be the same on both sides. Turn copper disc for one complete rotation, and see that the disc does not contact with magnet. (Fig. 16)</p> <p>(6) Assemble magnet case A and magnet case net with new tapping screws for mounting the cases.</p> | <div style="display: flex; justify-content: space-around;"> <div style="text-align: center;">  <p>(Fig. 14)</p> </div> <div style="text-align: center;">  <p>(Fig. 15)</p> </div> </div> <div style="text-align: center; margin-top: 20px;">  <p>(Fig. 16)</p> </div> |

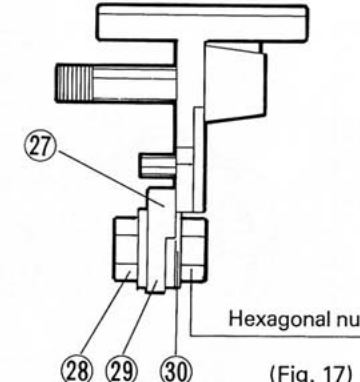
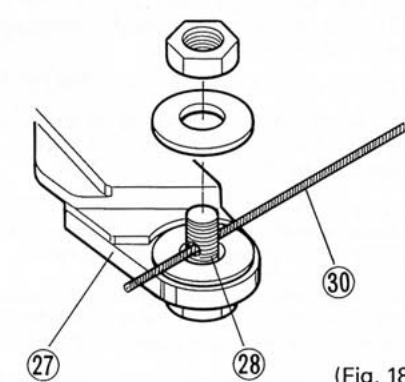
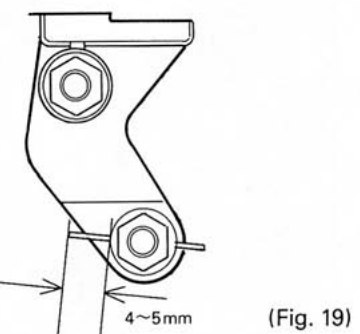
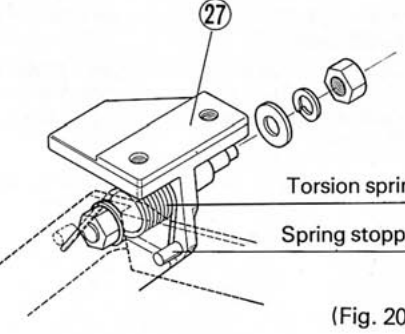
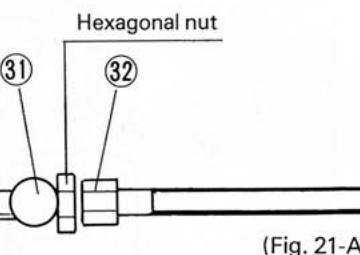
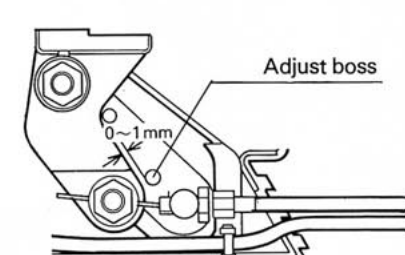
| No. | Replacing Magnet Mouting Base | EXPLANATION |
|---|-------------------------------|---|
| <p>S-5</p> <p>(1) Remove magnet case A and magnet case net from workload unit and take out copper disc. (Refer to S-4: Replacing Copper Disc, step 1 - 5.)</p> <p>(2) Take off magnet from magnet mounting base. (Refer to S-4: Replacing Magnet, step 2 - 3).</p> <p>(3) Move up grade shift lever to the top position to grade 0%.</p> <p>(4) Using spanner (B = 13) or monkey wrench, loosen the hexagonal nut holding magnet mounting base (27), and take out magnet mounting base, spring washer, flat washer and hexagonal nut.</p> <p>(5) Using two spanners (B = 13) or monkey wrenches, loosen hexagonal lock nut, and pull off inner wire which is attached to the magnet mounting base with inner wire set screw (28), spacer (29), flat washer and hexagonal lock nut. (Fig. 17)</p> <p>(6) Remove hexagonal lock nut and a flat washer from inner wire setting area of the new magnet mounting base, insert and draw the end of inner wire through the hole of set screw, protruding by 4 - 5 mm. from flat washer, place a flat washer and tighten lock nut with two spanners (B = 13) or monkey wrenches. (Fig. 18 and 19)</p> <p>(7) When placing magnet mounting base onto the spindle, place both ends of torsion spring in position to rest resiliently against spring stoppers provided inside magnet mounting base. Secure the mounting base with flat washer, spring washer and hexagonal nut. (Fig. 20)</p> <p>(8) <u>Adjustment of control wire on magnet mounting base.</u></p> <p>1. Loosen hexagonal nut for outer wire set screw (31), and tighten adjust bolt (32) to the full. (Fig. 21-A)</p> <p>2. Move down grade shift lever to its lowest position to grade 10%.</p> <p>3. Turning adjust bolt, adjust the clearance between magnet mounting base and adjust boss on Aluminium frame to 0-1 mm and lock adjust bolt by tightening hexagonal nut against outer wire set screw. (Fig. 21-B)</p> <p>(9) Assemble magnet to the magnet mounting base. (Refer to S-3: Replacing Magnet, step 4 - 5.)</p> <p>(10) Assemble copper disc. (Refer to S-3: Replacing Copper Disc.)</p> <p>(11) Assemble magnet case A and magnet case net with tapping screws for mounting covers.</p> | | <p style="text-align: center;">EXPLANATION</p> <div style="display: flex; justify-content: space-around;"> <div style="text-align: center;">  <p>Hexagonal nut</p> <p>(Fig. 17)</p> </div> <div style="text-align: center;">  <p>(Fig. 18)</p> </div> </div> <div style="display: flex; justify-content: space-around; margin-top: 20px;"> <div style="text-align: center;">  <p>4~5mm</p> <p>(Fig. 19)</p> </div> <div style="text-align: center;">  <p>Torsion spring</p> <p>Spring stopper</p> <p>(Fig. 20)</p> </div> </div> <div style="display: flex; justify-content: space-around; margin-top: 20px;"> <div style="text-align: center;">  <p>Hexagonal nut</p> <p>(Fig. 21-A)</p> </div> <div style="text-align: center;">  <p>Adjust boss</p> <p>0~1mm</p> <p>(Fig. 21-B)</p> </div> </div> |

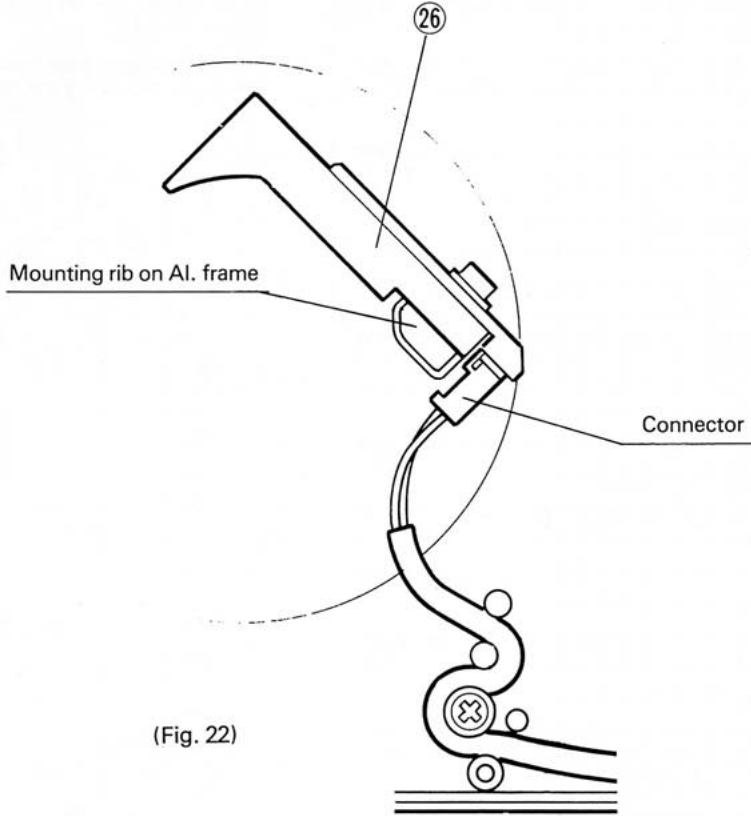
| No. | Replacing Roller Revolution Sensor | EXPLANATION |
|-----|--|--|
| S-6 | <ol style="list-style-type: none"> (1) Remove magnet case A, magnet case net, and copper disc from workload unit. (Refer to S-3: Replacing Copper Disc, step 1 - 5.) (2) Loosen set screw of roller revolution sensor (26) with screw driver. (Fig. 22) (3) Detach cord connector from roller revolution sensor. Connect cord connector to the new roller revolution sensor and place the sensor on the rib on Aluminium frame. (Do not assemble it with screw yet.) (4) Mount copper disc on spindle, and secure it tightly with flat washer, spring washer and hexagonal nut. (5) Tightly secure the roller revolution sensor with set screw. (6) Assemble magnet case A and magnet case net with tapping screws for mounting cases. |  <p>The diagram shows a roller revolution sensor assembly. A callout circle labeled '26' points to a set screw on the sensor. A label 'Mounting rib on Al. frame' points to a rib on the sensor's housing. Another label 'Connector' points to a cable connector attached to the sensor. Below the main assembly, a smaller detail shows a circular component with a cross symbol, likely the copper disc mentioned in the instructions, mounted on a spindle with a flat washer and a hexagonal nut. The entire diagram is labeled '(Fig. 22)'.</p> |

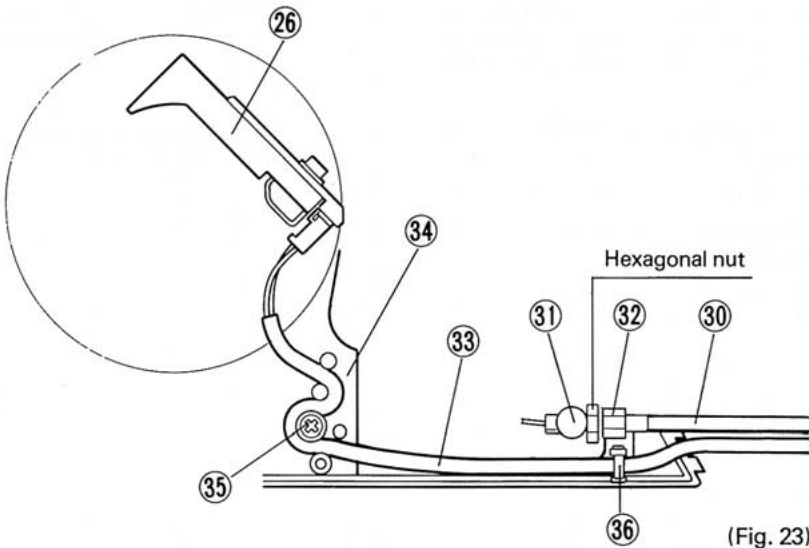
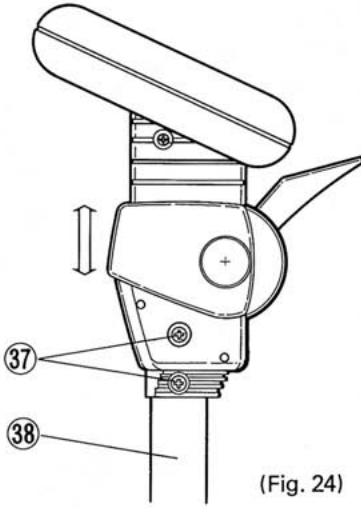
| No. | Replacing Grade Shift Lever Unit | EXPLANATION |
|-----|--|---|
| S-7 | <p><u>Removing revolution sensor cord and control wire from workload unit (Step 1 - 3):</u></p> <p>(1) Remove magnet case A, magnet case net and copper disc from workload unit. (Refer to S-3: Replacing Copper Disc, step 1 - 5.)</p> <p>(2) Take out magnet mounting base with magnet on, and detach inner wire from mounting base. (Refer to S - 5: Replacing Magnet Mounting Base, step 4 - 5.) Release adjust bolt (32) of control wire (30) from outer wire set screw (31), by loosening hexagonal lock nut. (Fig. 23)</p> <p>(3) Detach connector on revolution sensor cord (33) from revolution sensor (26), and loosen tapping screw with washer (35), which holds revolution sensor cord onto the workload cover B (34), with screw driver. Remove cord clamp (36) by cutting it with cutter or nippers. Pay attention to avoid damages on cord sheath.</p> <p><u>Removing work of revolution sensor cord and control wire from workload unit is completed now.</u></p> <p>(4) Take out control unit from grade shift lever unit. (Refer to S-1: Replacing Control Unit, step 1 - 6.)</p> <p>(5) With screw driver, loosen two screws (37) setting grade shift lever unit to control unit post. (Fig. 24)</p> <p>(6) Disengage wire and cord from wire hook on main tube. Take off grade shift lever unit from control unit post (38), together with wire and cord.</p> <p>(7) Pass wire and cord of the new grade shift lever unit through the control unit post, and assemble grade shift lever unit to control unit post with set screw.</p> <p>(8) Assemble control unit to the grade shift lever unit. (Refer to S-1: Replacing Control Unit.)</p> <p><u>Connecting revolution sensor cord and control wire to workload unit (Step 9 - 10):</u></p> <p>(9) Connect cord connector of revolution sensor to the sensor, place the cord in position as illustrated and hold it tightly with tapping screw with washer. Set cord clamp through the holes provided on magnet case B as shown, and cut off extruded portion by a cutter or nippers. (For setting the cord, refer to S-15: Adjustment of Cord Length at Roller Revolution Sensor.)</p> <p>(10) Set adjust bolt of control wire to the outer wire set screw and attach the wire to magnet mounting base. Assemble magnet mounting base with magnet to workload unit. (Refer to S-5: Replacing Magnet Mounting Base, step 6 - 8.)</p> | <p>(11) Place copper disc in position. (Refer to S-3: Replacing Copper Disc.)</p> <p>(12) Assemble magnet case A and magnet case net with tapping screws for mounting the cases.</p>  <p>(Fig. 23)</p>  <p>(Fig. 24)</p> |

| No. | Replacing Workload Unit | EXPLANATION |
|-----|---|-------------|
| S-8 | <ol style="list-style-type: none"> <li data-bbox="322 245 947 320">(1) Detach revolution sensor cord and control wire from the workload unit. (Refer to S-7: Replacing Grade Shift Lever Unit, step 1 - 3.) <li data-bbox="322 336 947 411">(2) Remove magnet case A, magnet case net, and copper plate from the new workload unit. (Refer to S-3: Replacing Copper Disc, step 1, 3 - 5.) <li data-bbox="322 427 947 502">(3) Take out magnet mounting base with magnet on, from the new workload unit. (Refer to S-5: Replacing Magnet Mounting Base, step 5.) <li data-bbox="322 518 947 564">(4) Connect revolution sensor cord to the new workload unit. (Refer to S-7: Replacing Grade Shift Lever Unit, step 9.) <li data-bbox="322 580 947 676">(5) Set adjust bolt of control wire to the outer wire set screw, and attach the wire to magnet mounting base. Assemble magnet mounting unit with magnet to the workload unit. (Refer to S-5: Replacing Magnet Mounting Base, step 6 - 8.) <li data-bbox="322 692 947 738">(6) Assemble copper disc. (Refer to S-3: Replacing Copper Disc.) <li data-bbox="322 754 947 801">(7) Assemble magnet case A and magnet case with tapping screws for mounting the cases. | |

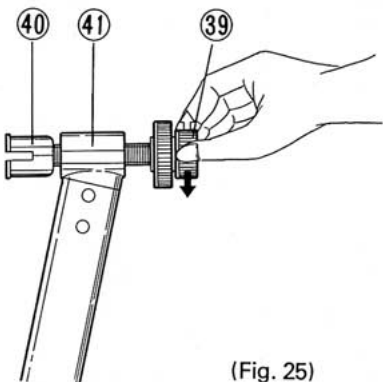
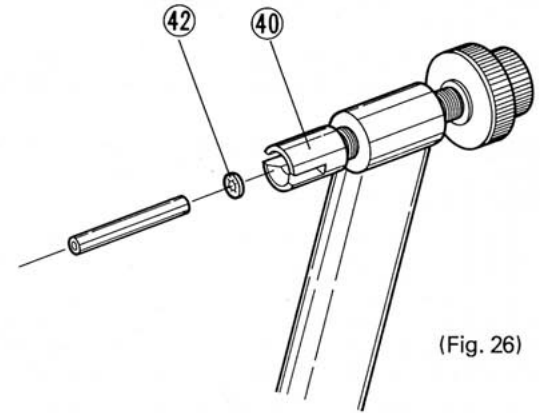
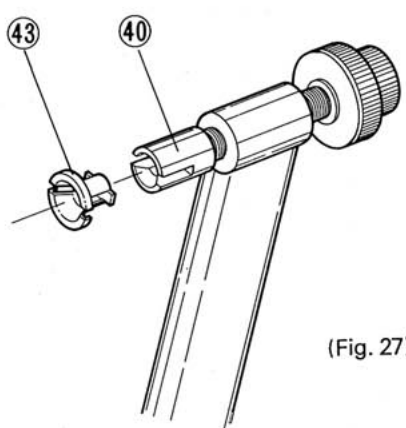
| No. | Replacing Clamp Cone | EXPLANATION |
|-----|--|---|
| S-9 | <p>(1) Turn outer knob (39) counter-clockwise until clamp cone (40) comes in contact with main frame arm. Turning it further in the same direction, clamp cone will come out of clamp bolt. (Fig. 25)</p> <p>(2) Turning outer knob clockwise, bring end portion of clamp bolt out of frame arm, and place new clamp cone thereon.</p> <p>(3) Press in push nut (42) in position to ride on the boss at the inner end of clamp cone hole, using a socket or tube of 10 - 12 mm, OD. (Fig. 26)</p> <p>(4) Insert cone cap (43) to the clamp cone. (Fig. 27)</p> |  <p>(Fig. 25)</p>  <p>(Fig. 26)</p>  <p>(Fig. 27)</p> |

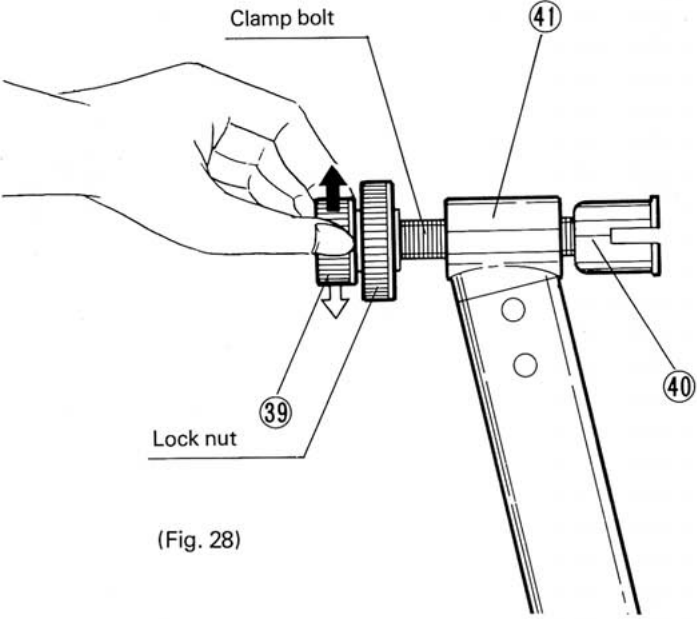
| No. | Replacing Clamp Bolt | EXPLANATION |
|------|--|---|
| S-10 | <p>(1) Turn outer knob (39) counter-clockwise until clamp cone (40) comes in contact with main frame arm. Turning it further in the same direction, clamp cone will come out of clamp bolt. Take out clamp bolt from main frame arm.</p> <p>(2) Remove lock nut from clamp bolt and mount it on the new clamp bolt. (Fig. 28)</p> <p>(3) Place new clamp bolt into main frame arm, and assemble clamp cone and cone cap. (Refer to S-9: Replacing Clamp Cone, step 2 - 4.)</p> |  <p>The diagram illustrates the removal of the clamp bolt from the main frame arm. A hand is shown turning the outer knob (39) counter-clockwise, which causes the clamp cone (40) to move out of the clamp bolt (41). A lock nut is also shown on the bolt. The main frame arm is shown with two holes. The diagram is labeled (Fig. 28).</p> |

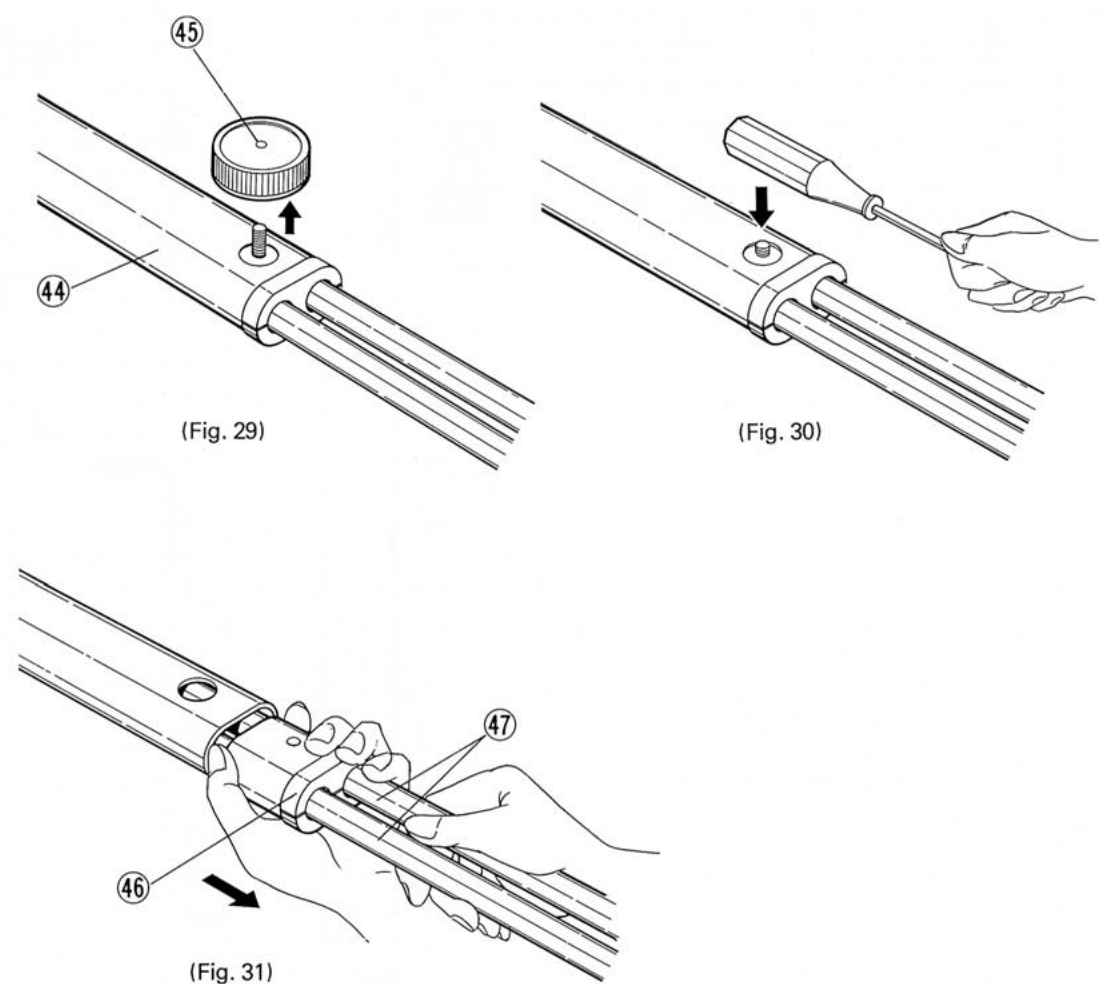
| No. | Replacing Inner Tube | EXPLANATION |
|------|--|--|
| S-11 | <p>(1) Unhook wire and cord from wire hook.</p> <p>(2) Remove front main tube knob (45) from front main tube (44). (Fig. 29)</p> <p>(3) Remove knob bolt by lightly tapping its protrudent tip with a screw driver shank or else. Remove flat washer as well. (Fig. 30)</p> <p>(4) Holding front main tube, pull out inner tube (47) gripping on wire hook (46). (Fig. 31)</p> <p>(5) Pull off inner tube out of rear main tube in the same way.</p> <p>(6) Assemble tube spacer on new inner pipe with wire hook portion underside, and insert it fully into main tube as far as it goes.</p> <p>(7) Push in knob bolt (removed in step 3) into the hole on main tube from underside.</p> <p>(8) Place flat washer at knob bolt, and lightly set with outer knob.</p> |  <p>(Fig. 29)</p> <p>(Fig. 30)</p> <p>(Fig. 31)</p> |

| No. | Replacing Fan Case | EXPLANATION |
|------|---|---|
| S-12 | <p>(1) Remove fan cover (48) from workload unit. Holding turbo fan, or flywheel by hand, remove setting nut of flywheel with spanner (B = 13) or monkey wrench, and take out turbo fan, flywheel, flat washer and spring washer. (Fig. 32, 33)</p> <p>(2) Remove two hexagonal tapping screws (49) with screw driver, from fan case. Take off magnet case A (21) and magnet case net. Removing tapping screw (51) on fan case, take out fan case from magnet case B (50). (Fig. 33, 34 and 35)</p> <p>(3) Remove fan cover from replacement fan case, and assemble fan case to workload unit with two hexagonal tapping screws and tapping screw from magnet case B side. Assemble magnet case A and magnet case net.</p> <p>(4) Mount flywheel, flat washer, and spring washer in position, and secure them with hexagonal nut.</p> <p>(5) Assemble fan cover.</p> | <p>(Fig. 32)</p> <p>(Fig. 33)</p> <p>(Fig. 34)</p> <p>(Fig. 35)</p> |

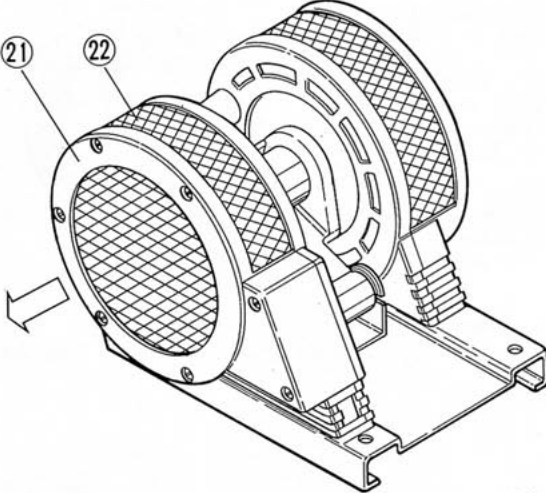
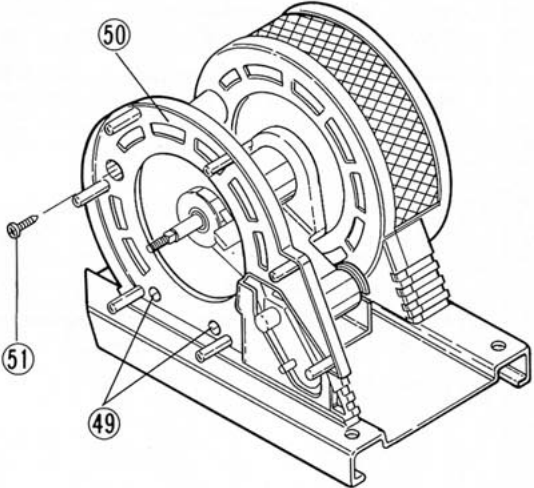

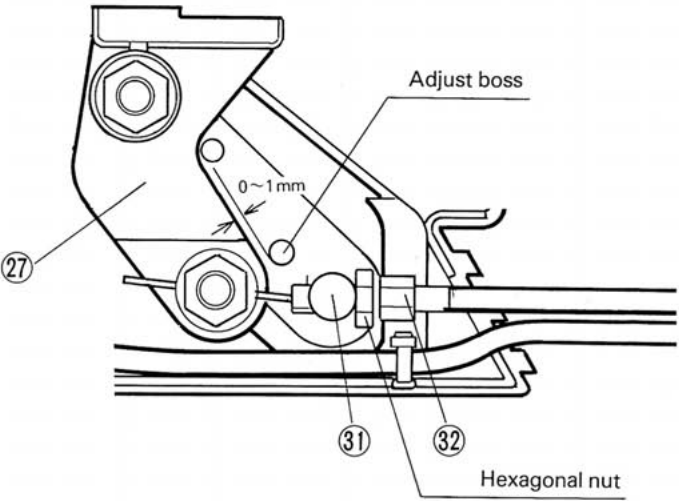

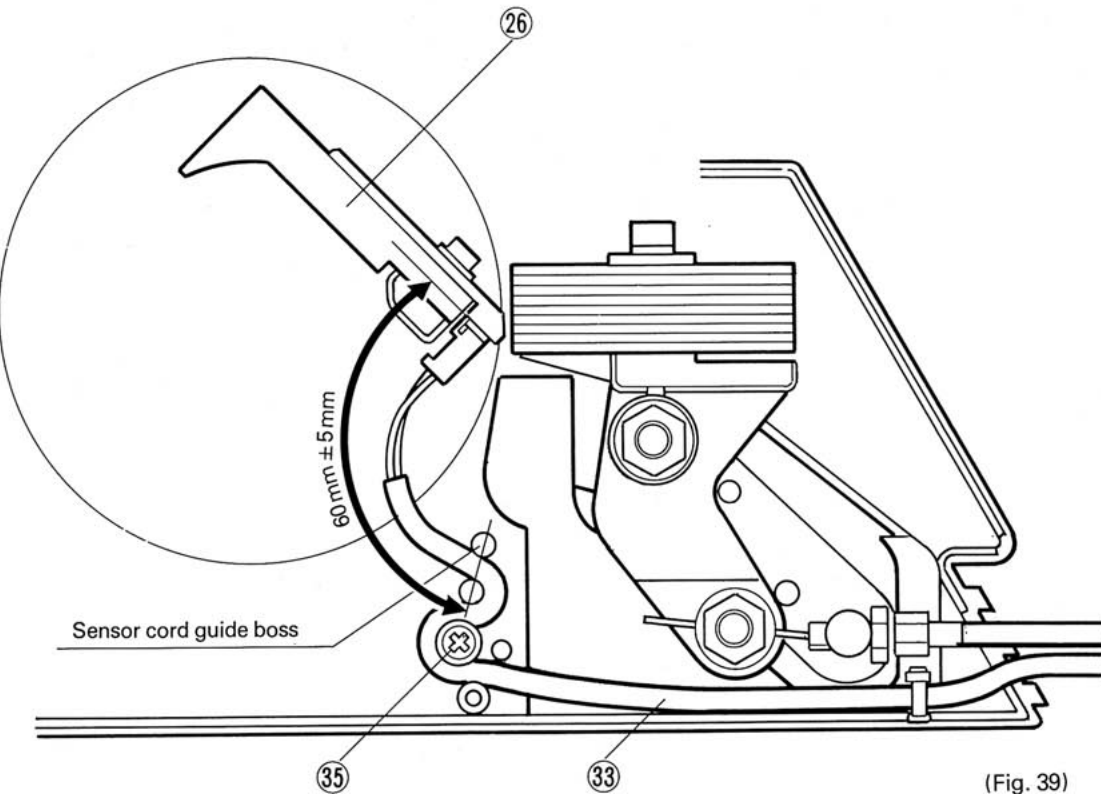

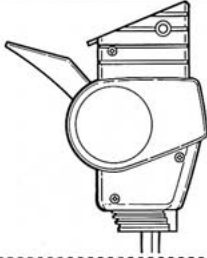
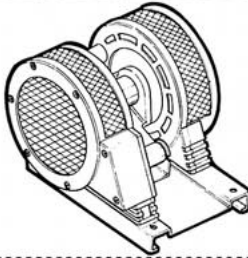
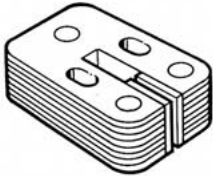
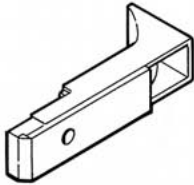

| No. | Replacing Magnet Case | EXPLANATION |
|------|---|--|
| S-13 | <p><u>Replacing magnet case A and magnet case net:</u></p> <ol style="list-style-type: none"> (1) Removing tapping screws on magnet case A (21) with screw driver, take out magnet case A and magnet case net (22) from workload unit. (Fig. 36) Pay attention on sharp edges of net for finger injury. (2) Assemble replacement magnet case A and magnet case net with tapping screws. <p><u>Replacing magnet case set:</u></p> <ol style="list-style-type: none"> (1) Take out magnet case A, magnet case net, copper disc, magnet mounting base, revolution sensor cord and control wire from workload unit. (Refer to S-7: Replacing Grade Shift Lever Unit, step 1 - 3.) (2) With a screw driver, remove two hexagonal tapping screws (49) on magnet case B (50). Also remove tapping screw (51) which holds magnet case B to the fan case, and take out magnet case B. (Fig. 37) (3) Assemble replacement magnet case B to workload unit with two hexagonal tapping screws, and to the fan case with a tapping screw. (4) Assemble revolution sensor cord, control wire, magnet mounting base, and magnet case A onto workload unit. (Refer to S-7: Replacing Grade Shift Lever Unit, step 9 - 12.) | <div style="display: flex; justify-content: space-around; align-items: flex-end;"> <div style="text-align: center;">  <p>(Fig. 36)</p> </div> <div style="text-align: center;">  <p>(Fig. 37)</p> </div> </div> |

| No. | Adjustment of Control Wire | EXPLANATION |
|------|---|--|
| S-14 | <p>(1) Using screw driver, remove tapping screws which hold magnet case A (21) onto workload unit, and take out magnet case A and magnet case net (22). Pay attention on sharp edges of net for finger injury.</p> <p>(2) Move down grage shift lever to the low end to grade 10%.</p> <p>(3) Loosen hexagonal nut for outer wire set screw (31).</p> <p>(4) Turning adjust bolt (32), adjust the clearance between adjust boss on Aluminium frame and magnet mounting base (27) to abt. 0 - 1 mm., and tighten hexagonal nut securely against outer wire set screw. (Fig. 38)</p> <p>(5) Assemble magnet case A and magnet case net.</p> |  <p>(Fig. 38)</p> |

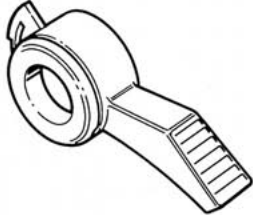
| No. | Adjustment of Cord Length at Roller Revolution Sensor | EXPLANATION |
|------|---|---|
| S-15 | <ol style="list-style-type: none"> (1) Take out magnet case A, magnet case net, and copper disc from workload unit. (Refer to S-3: Replacing Copper Disc, step 1 - 5.) (2) Disconnect connector of revolution sensor cord (33) from revolution sensor (26). (3) Using screw driver, remove tapping screw with washer (35) holding the revolution sensor cord in position. (4) Take out revolution sensor cord from guide boss, and reset the cord in position, keeping the length of abt. 60 mm. from upper side of guide boss upto the end of cord connector. (5) Tighten tapping screw with washer to fix the cord. (6) Connect cord connector to the revolution sensor. (7) Assemble copper disc, magnet case net and magnet case A in position. (Refer to S-3: Replacing Copper Disc.) |  <p style="text-align: right;">(Fig. 39)</p> |

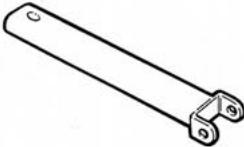

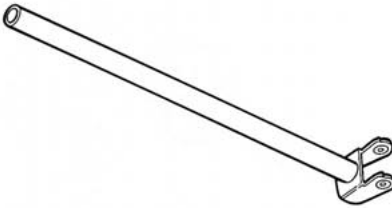
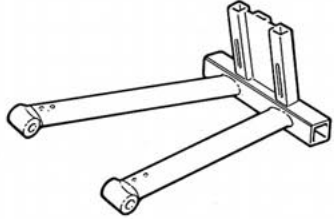
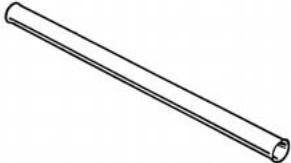







CATEYE CYCLOSIMULATOR EXTRA PART & ACCESSORIES

CS-PLE: 891124

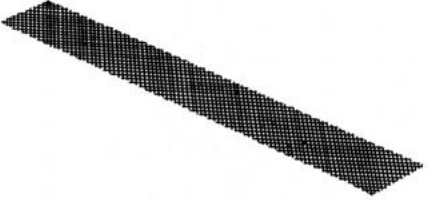
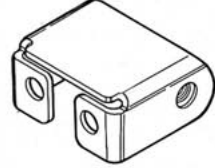
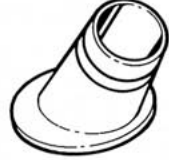
| | | | |
|--|--|--|--|
|  |  |  |  |
| <p>CS - 1000 Control unit Box quantity: 5 pcs. PNR. 7820000</p> | <p>CS - 1000 Grade shift lever unit Box quantity: 5 pcs. PNR. 7820100</p> | <p>CS - 1000 Workload unit Box quantity: 1 pc. PNR. 7820200</p> | <p>CS - 1000 Magnet set Box quantity: 5 pcs. PNR. 7820210</p> |
|  |  |  |  |
| <p>CS - 1000 Roller revolution sensor set Box quantity: 5 pcs. PNR. 7820220</p> | <p>CS - 1000 Copper disc Box quantity: 5 pcs. PNR. 7820230</p> | <p>CS - 1000 Grade shift lever Box quantity: 5 pcs. PNR. 7820110</p> | <p>CS - 1000 Front main tube Box quantity: 5 pcs. PNR. 7822100</p> |
|  |  |  |  |
| <p>CS - 1000 Rear main tube Box quantity: 5 pcs. PNR. 7822110</p> | <p>CS - 1000 Front leg Box quantity: 5 pcs. PNR. 7822120</p> | <p>CS - 1000 Control unit stand Box quantity: 5 pcs. PNR. 7822130</p> | <p>CS - 1000 Main frame Box quantity: 2 pcs. PNR. 7822140</p> |
|  |  | | |
| <p>CS - 1000 Inner tube Box quantity: 20 pcs. PNR. 7822150</p> | <p>CS - 1000 Front cap Box quantity: 10 pcs. PNR. 7081212</p> | | |

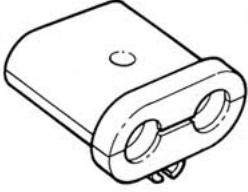

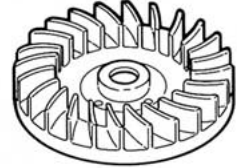

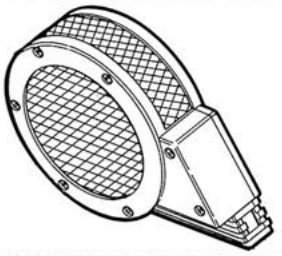





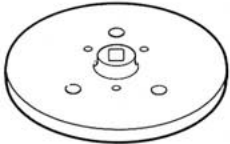

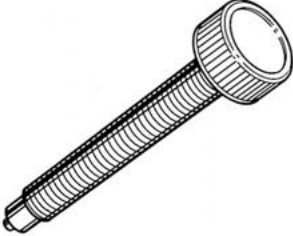
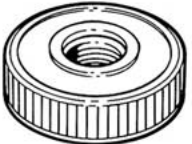

CATEYE CYCLOSIMULATOR EXTRA PART & ACCESSORIES

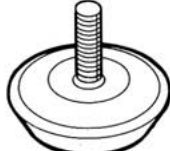
CS- PLE: 891124

| | | | |
|--|---|--|--|
|  |  |  |  |
| <p>CS-1000 Workload mounting bracket Box quantity: 20 pcs. PNR. 7822030</p> | <p>CS-1000 Front leg spacer Box quantity: 20 pcs. PNR. 7822020</p> | <p>CS-1000 Pedal hook Box quantity: 10 pcs. PNR. 7822000</p> | <p>CS-1000 Pedal stopper Box quantity: 10 pcs. PNR. 7822010</p> |
|  |  |  |  |
| <p>CS-1000 Magnet/fan case net Box quantity: 10 sets PNR. 7822040</p> | <p>CS-1000 Joint fitting Box quantity: 10 pcs. PNR. 7822050</p> | <p>CS-1000 Front leg cap Box quantity: 20 pcs. PNR. 7821100</p> | <p>CS-1000 Main frame leg cap R, L Box quantity: 10 sets. PNR. 7821110</p> |
|  |  |  |  |
| <p>CS-1000 Main tube cap Box quantity: 10 pcs. PNR. 7821120</p> | <p>CS-1000 Cone cap Box quantity: 20 pcs. PNR. 7821200</p> | <p>CS-1000 Fork post cap Box quantity: 20 pcs. PNR. 7821040</p> | <p>CS-1000 Turbo fan Box quantity: 10 pcs. PNR. 7821050</p> |
|  |  | | |
| <p>CS-1000 Fan case set A, B Box quantity: 5 sets PNR. 7821010</p> | <p>CS-1000 Magnet case set A, B Box quantity: 5 sets PNR. 7821020</p> | | |









CATEYE CYCLOSIMULATOR EXTRA PART & ACCESSORIES

CS- PLE: 891124

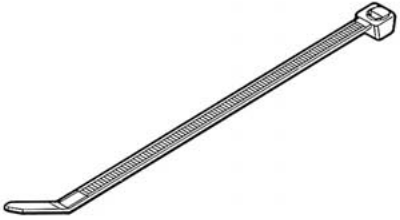
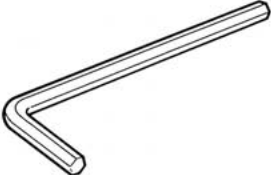
| | | | |
|---|---|---|---|
|  |  |  |  |
| <p>CS-1000 Flywheel Box quantity: 5 pcs. PNR. 7825000</p> | <p>CS-1000 Clamp cone Box quantity: 10 pcs. PNR. 7825010</p> | <p>CS-1000 Outer knob Box quantity: 10 pcs. PNR. 7825020</p> | <p>CS-1000 Lock nut Box quantity: 10 pcs. PNR. 7825030</p> |
|  |  |  |  |
| <p>CS-1000 Rear main tube knob Box quantity: 10 pcs. PNR. 7825040</p> | <p>CS-1000 Pedal hook spring Box quantity: 10 pcs. PNR. 7825100</p> | <p>Cap bolt M8 x 45 (for fastening main tube) Box quantity: 100 pcs. PNR. 7500845</p> | <p>3-pc cap bolt M8 x 18 (for mounting workload unit, metal joint, front leg, and control unit post) Box quantity: 100 pcs. PNR. 7573818</p> |
|  |  |  |  |
| <p>EC-1000 Leveler (for adjusting workload) Box quantity: 20 pcs. PNR. 7243950</p> | <p>Hexagonal nut M8-1 (for mounting copper disc, and flywheel) Box quantity: 100 pcs. PNR. 7521081</p> | <p>Flat washer 8-17-1.6 (for mounting copper disc, and flywheel) Box quantity: 100 pcs. PNR. 7531817</p> | <p>Flat washer 6-18-2.0 (for mounting magnet) Box quantity: 100 pcs. PNR. 7532019</p> |
|  |  |  |  |
| <p>Flat washer 5-12-1.0 (for mounting turbo fan) Box quantity: 100 pcs. PNR. 7531512</p> | <p>Spring washer 8 (for mounting copper disc, and flywheel) Box quantity: 100 pcs. PNR. 7530800</p> | <p>Spring washer 5 (for mounting magnet, and turbo fan) Box quantity: 100 pcs. PNR. 7530500</p> | <p>Push nut 4 Box quantity: 100 pcs. PNR. 7529400</p> |

CATEYE CYCLOSIMULATOR EXTRA PART & ACCESSOIRES

CS- PLE: 891124

| | | | |
|--|--|--|---|
|  |  |  |  |
| <p>Tapping screw S 5 × 12 (for mounting turbo fan) Box quantity: 100 pcs. PNR. 7517912</p> | <p>Cap bolt M5 × 28 (for mounting magnet) Box quantity: 100 pcs. PNR. 7571528</p> | <p>Tapping screw 4 × 40 with washer (for mounting magnet case, and fan case) Box quantity: 100 pcs. PNR. 7515440</p> | <p>Cord clamp CV - 150 (for mounting sensor cord) Box quantity: 100 pcs. PNR. 7295010</p> |
|  |  |  |  |
| <p>L-shape wrench B = 6 (for assembling CS-1000) Box quantity: 10 pcs. PNR. 7580260</p> | <p>CS - 1000 Operating instructions J Box quantity: 10 pcs. PNR. 9689961</p> | <p>CS - 1000 Operating instructions E Box quantity: 10 pcs. PNR. 9689960</p> | <p>CS - 1000 Operating instructions G Box quantity: 10 pcs. PNR. 9689962</p> |
|  |  |  | |
| <p>CS - 1000 Operating instructions F Box quantity: 10 pcs. PNR. 9689963</p> | <p>CS - 1000 Operating instructions I Box quantity: 10 pcs. PNR. 9689964</p> | <p>CS - 1000 Operating instructions D Box quantity: 10 pcs. PNR. 9689965</p> | |
| | | | |



CATEYE CO., LTD.

2-8-25, Kuwazu, Higashi Sumiyoshi-ku, OSAKA, JAPAN.
PHONE: (06) 719-7781 FAX: (06) 719-2362
TELEX: 5277962 CATEYE J

Free Manuals Download Website

<http://myh66.com>

<http://usermanuals.us>

<http://www.somanuals.com>

<http://www.4manuals.cc>

<http://www.manual-lib.com>

<http://www.404manual.com>

<http://www.luxmanual.com>

<http://aubethermostatmanual.com>

Golf course search by state

<http://golfingnear.com>

Email search by domain

<http://emailbydomain.com>

Auto manuals search

<http://auto.somanuals.com>

TV manuals search

<http://tv.somanuals.com>