

CELESTRON[®]



THE CELESTRON C4.5 --- INSTRUCTION MANUAL

TABLE OF CONTENTS

▲ INTRODUCTION	1
How to Use This Manual	2
A Word of Caution	2
The Newtonian Optical System	3
▲ ASSEMBLING YOUR C4.5	4
Unpacking Your C4.5	4
Attaching the Mount to the Tripod	6
Attaching the Accessory Tray	7
Adjusting the Mount	8
Attaching the DEC Slow Motion Knob	8
Attaching the R.A. Slow Motion Knob	9
Attaching the Counterweight Bar	10
Attaching the Telescope to the Mount	11
Installing the Eyepiece	12
Disassembling and Transporting Your C4.5	13
Storing Your C4.5	13
Technical Specifications	14
▲ BASIC OPERATION	15
Moving the Telescope in R.A. and DEC	15
Balancing the Telescope in R.A.	16
Balancing the Telescope In DEC	17
Adjusting the Mount	18
▲ GETTING STARTED	19
Image Orientation	19
Focusing	20
Aligning the Finder	21
Your First Look	22
Daytime Observing	22
Nighttime Observing	23
Calculating Magnification (Power)	24
Determining the Field of View	24
▲ ASTRONOMY BASICS	25
The Celestial Coordinate System	25
Motion of the Stars	26
Polar Alignment	27
Finding the Pole	28
The Latitude Scale	29
Pointing at Polaris	30
Declination Drift	31
Aligning the R.A. Setting Circle	32
▲ CELESTIAL OBSERVING	33
Observing the Moon	33
Observing the Planets	33
Observing the Sun	34
Observing Deep-Sky Objects	35
Using the Setting Circles	35
Star Hopping	36
Viewing Conditions	38
Transparency	38
Sky Illumination	38
Seeing	38
▲ CELESTIAL PHOTOGRAPHY	40
Short Exposure Prime Focus	41
Eyepiece Projection	43
▲ TELESCOPE MAINTENANCE	45
Care and Cleaning of the Optics	45
Collimation	46
Aligning the Secondary Mirror	47
Aligning the Primary Mirror	48
▲ OPTIONAL ACCESSORIES	49
▲ THE MESSIER CATALOG	52
▲ LIST OF BRIGHT STARS	55
▲ FOR FURTHER READING	56

I N T R O D U C T I O N

Welcome to the Celestron world of amateur astronomy! Celestron has been providing amateur astronomers with the tools needed to explore the universe for more than a quarter of a century. The Celestron C4.5 continues in this proud tradition. With a mirror diameter of four and a half inches, the C4.5 has 265 times the light gathering power of the unaided human eye. It can show literally hundreds of planetary and deep-sky objects. Yet the C4.5 is compact enough to take to the mountains or desert or wherever you observe.

The C4.5 is made of the highest quality materials to ensure durability and stability. All this adds up to a telescope that will give you a lifetime of pleasure with a minimal amount of maintenance. In addition, your Celestron C4.5 is versatile — it will grow as your interest grows. All you need to do is take the time to familiarize yourself with your telescope and its operation.

How to Use this Manual

This manual is designed to instruct you in the proper use of your Celestron C4.5 telescope. The instructions are for assembly, initial use, long term operation, and maintenance. There are six major sections to the manual. The first section covers the proper procedure for setting up your Celestron C4.5 telescope.

The second section covers basic operation such as moving the telescope, adjusting the mount, and proper balance of your C4.5. The third section deals with the basics of astronomy. Topics include focusing, aligning the finder, and taking your first look. The fourth section deals with the basics of astronomy which includes celestial coordinate system, the motions of the stars, and polar alignment. The fifth section deals with celestial photography covering all major forms working from the easiest to the most difficult. The last major section is on telescope maintenance, specifically on cleaning and collimation. Keeping your C4.5 in proper collimation is the single most important thing you can do to ensure it performs well.

The final part of this manual contains a list of objects that can be observed through your Celestron C4.5 telescope. Included are the coordinates for each object, its brightness, and a code which indicates what type of an object it is. In addition, there is a list of bright stars that can be used for aligning the setting circles. In addition to the major sections mentioned previously, there is a list of optional accessories for your Celestron C4.5 that include a brief description of its purpose. This is the section to consult when you've mastered the basics and ready for new, more challenging observations.

Read the assembly instructions through completely before you attempt to set up your C4.5 telescope. Then, once you've set up your C4.5, read the section on "Basic Operation" before you take it outside and use it. This will ensure that you are familiar with your telescope before you try to use it under a dark sky. Since it will take a few observing sessions to familiarize yourself with your C4.5, you should keep this manual handy until you have fully mastered your telescope's operation. After that, save the manual for future reference.

A Word of Caution

Your Celestron C4.5 is designed to give you hours of fun and rewarding observations. There are, however, a few things to consider before using your telescope that will ensure your safety and protect your eyes and your equipment.

WARNING !

NEVER LOOK DIRECTLY AT THE SUN WITH THE NAKED EYE OR WITH A TELESCOPE. NEVER POINT YOUR TELESCOPE AT THE SUN UNLESS YOU HAVE THE PROPER MYLAR SOLAR FILTER. PERMANENT AND IRREVERSIBLE EYE DAMAGE MAY RESULT AS WELL AS DAMAGE TO YOUR TELESCOPE.

NEVER USE YOUR TELESCOPE TO PROJECT AN IMAGE OF THE SUN ONTO ANY SURFACE. INTERNAL HEAT BUILD-UP CAN DAMAGE ANY ACCESSORIES ATTACHED TO THE TELESCOPE.

NEVER LEAVE THE TELESCOPE UNSUPERVISED, ESPECIALLY WHEN CHILDREN ARE PRESENT OR OTHER ADULTS WHO MAY NOT BE FAMILIAR WITH THE CORRECT OPERATING PROCEDURES OF YOUR TELESCOPE.

NEVER USE AN EYEPIECE SOLAR FILTER OR A HERSHEL WEDGE SOLAR FILTER. INTERNAL HEAT BUILD-UP INSIDE THE TELESCOPE CAN CAUSE THESE DEVICES TO CRACK OR BREAK ALLOWING UNFILTERED SUNLIGHT TO PASS THROUGH TO THE EYE.

NEVER POINT YOUR TELESCOPE AT THE SUN UNLESS YOU HAVE THE PROPER SOLAR FILTER. WHEN USING YOUR TELESCOPE WITH THE CORRECT SOLAR FILTER, ALWAYS COVER THE FINDER. ALTHOUGH SMALL IN APERTURE, THIS INSTRUMENT HAS ENOUGH LIGHT GATHERING POWER TO CAUSE PERMANENT AND IRREVERSIBLE EYE DAMAGE. FURTHERMORE, THE IMAGE PROJECTED BY THE FINDER IS HOT ENOUGH TO BURN SKIN OR CLOTHING.

The Newtonian Optical System

The Newtonian reflector was developed by Isaac Newton in the early 1700's and therefore carries his name. This type of telescope uses a parabolic primary mirror to focus the light rays it collects. In addition to focusing the light, the mirror also redirects it toward the front of the telescope tube where the light entered. Near the front of the tube, the light rays are intercepted by a small flat mirror (called an elliptical flat) and directed out of the telescope tube at a 90° angle to the incoming light rays (see figure 1-1). It is here that the eyepiece is placed to view the image formed by the telescope.

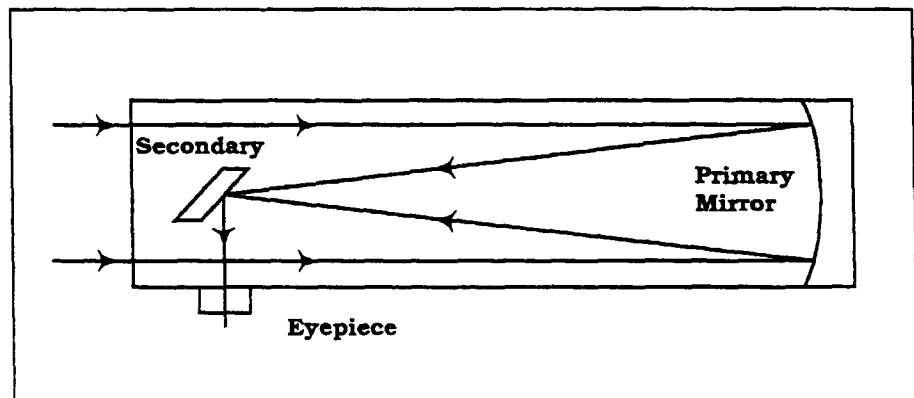

Figure 1-1

This cross sectional diagram shows the light path of the Newtonian optical system.

A S S E M B L I N G Y O U R C 4 . 5

This section covers the assembly instruction for your C4.5 telescope. The C4.5 telescope is shipped in one box, which contains:

- Telescope Tube
- 26mm Plössl Ocular 1-1/4"
- 6x30 Finder and Bracket
- Polaris German Equatorial Mount
- Counterweight Bar
- Counterweight
- Declination (DEC) Slow Motion Knob
- Right Ascension (R.A.) Slow Motion Knob
- Wooden Tripod
- Accessory Tray
- Lens Cap
- Allen Wrench

Use the diagram on the following page (figure 2-1) and other drawings throughout this manual to familiarize yourself with the various parts of your C4.5 telescope for assembly and on-going use. Remember, read this section through carefully before you set up your telescope.

Unpacking Your C4.5

When setting up your C4.5 telescope, find a large, clear area where the parts can be laid out without fear of losing them. Remove the contents of the box and place them neatly on your work surface.

Once your C4.5 telescope has been unpacked and assembled, you will not need the box for everyday storage and transportation. However, you should save the box in case you decide to ship your telescope via a common carrier.

These instructions are laid out in the order each task must be performed.

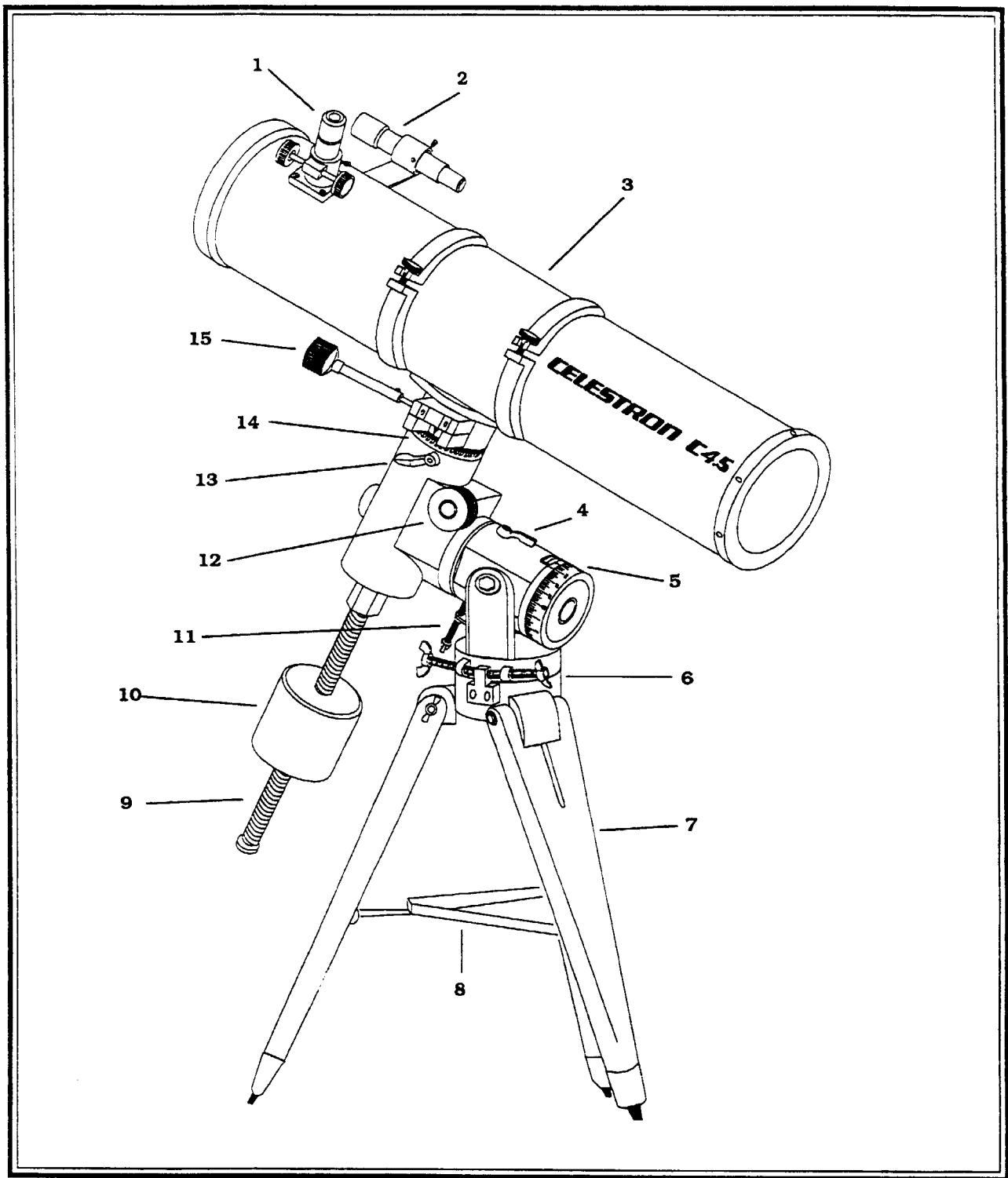

Figure 2-1

- | | |
|-----------------------------|-------------------------------|
| 1. Eyepiece | 9. Counterweight Bar |
| 2. Finder and Bracket | 10. Counterweight |
| 3. Telescope | 11. Altitude Adjustment Screw |
| 4. R.A. Clamp | 12. R.A. Slow Motion Knob |
| 5. R.A. Setting Circle | 13. DEC Clamp |
| 6. Azimuth Adjustment Screw | 14. DEC Setting Circle |
| 7. Tripod | 15. DEC Slow Motion Knob |
| 8. Accessory Tray | |

Attaching the Mount to the Tripod

In order for the tripod to stand, the equatorial mount must be attached. To do this:

1. Locate the long bolts that attach the mount to the tripod head.
2. Remove the wing nut and one of the washers from the bolt.
3. Insert the bolt with remaining washer through the top of the tripod leg.
4. Install the washer and wing nut onto the bolt. Thread the wing nut on about two full turns. Do NOT tighten fully or you will pinch the tripod leg which will prevent the mount from sliding onto the leg.
5. Slide the mount onto each tripod leg, one at a time. Orient the legs so that the accessory tray support brackets are on the inside (see figure 2-2).
6. Tighten each wing nut and bolt completely to hold the mount securely in place.
7. Spread the legs slightly and the tripod will now stand by itself.

Once this is done, you are ready to attach the accessory tray.

NOTE:

Variations in temperature and/or humidity can cause the tripod legs to expand and contract. This expansion and contraction can cause the bolts that hold the tripod legs in place to loosen **WITHOUT** warning. As a result, you should periodically check these bolts to ensure that they are tight. Also, apply lemon oil to the legs occasionally to prevent them from drying out and warping.

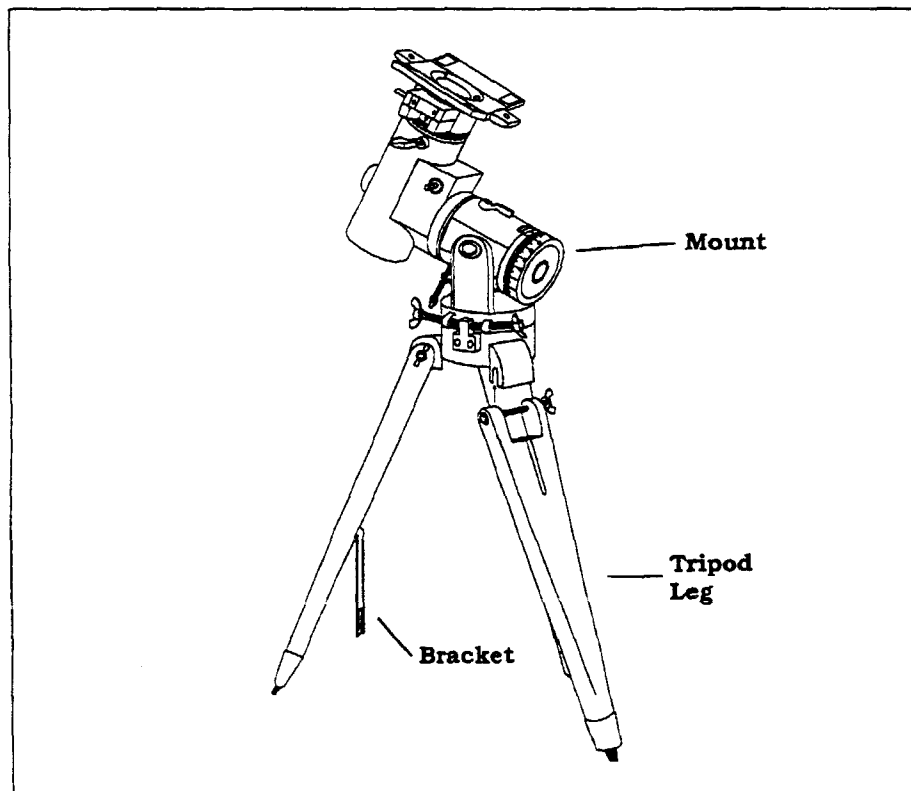

Figure 2-2

Attaching the Accessory Tray

Once the tripod is standing you are ready to attach the accessory tray. To do this:

1. Locate the wing nuts used to hold the accessory tray to the bracket.
2. Locate the brackets that holds the accessory tray. The brackets will be hanging down inside the tripod.
3. Hold one of the brackets up so that it is parallel to the ground.
4. Insert one of the screws on the bottom of the accessory tray through the hole in the bracket. The screw should go through the top of the accessory tray and protrude out the bottom.
5. Thread the wing nut onto the screw of the accessory tray to hold it in place. Repeat this process for the other two brackets (see figure 2-3).
6. Pull the tripod legs apart as far as they can go. This will give you a wider, more stable base.
7. Tighten the wing nuts that hold the accessory tray in place.
8. Tighten the wing nuts that hold the tripod legs to the mount for added stability.

With the accessory tray in place, the tripod is much more stable, making it easier to attach the telescope.

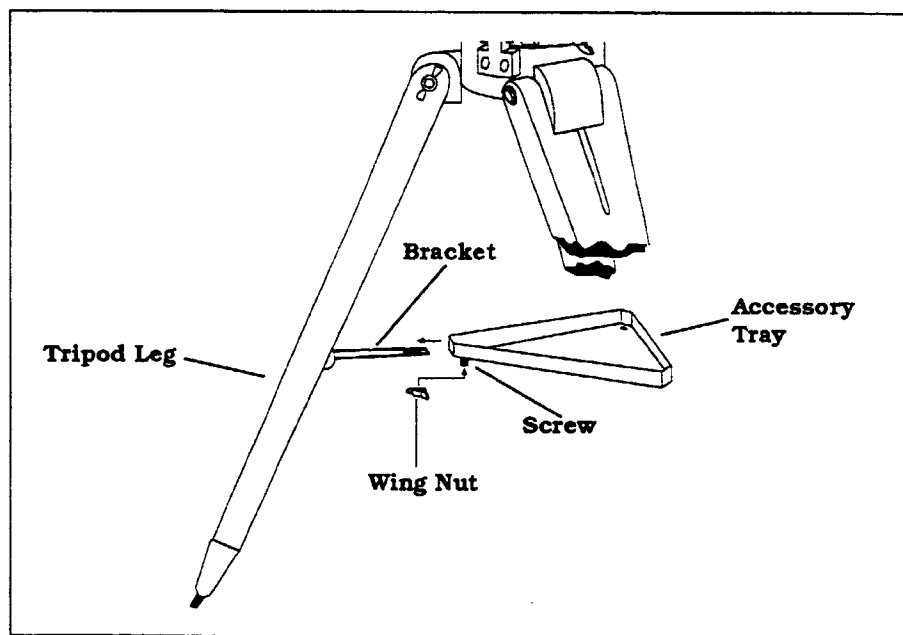
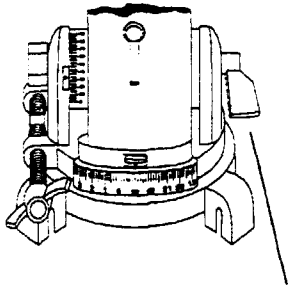

Figure 2-3

Adjusting the Mount



Altitude Locking Clamp

Figure 2-4

Before going further, it is a good idea to adjust the mount to a more convenient position for attaching the accessories and telescope. The mount is shipped with the declination (DEC) setting circle in the 0° position and the mount in the 90° position.

1. Loosen the altitude locking clamp (see figure 2-4).
2. Swing the mount until the latitude scale points to the latitude of your observing site (see figure 2-4). Tighten the altitude adjustment screw.
3. Tighten the altitude locking clamp to hold the mount in place.
4. Loosen the declination clamp and move the telescope mounting platform until the declination circle reads 90° . Swing the mount so that the DEC slow motion shaft points up. This allows for easy access to the DEC slow motion knob when looking through the telescope.

Attaching the DEC Slow Motion Knob

With the mount securely in place, you are ready to attach some of the accessories (the telescope tube is added last). Start with the declination (DEC) slow motion knob. The DEC slow motion knob allows you to make fine adjustments in the direction the telescope is pointing (once it is attached to the mount). The shaft that the DEC slow motion knob fits over is toward the top of the mount, just above the declination setting circle. To install the DEC slow motion knob:

1. Loosen the set screw on the DEC slow motion knob until the tip of the screw no longer extends into the inner diameter of the sleeve. You will need a standard flat-blade screwdriver (or an Allen wrench) to perform this task.
2. Orient the metal sleeve so that the set screw is over the flat portion of the DEC shaft (see figure 2-6).
3. Slide the metal sleeve on the DEC slow motion knob over the DEC shaft (see figure 2-5).
4. Tighten the set screw to hold the DEC slow motion knob firmly in place.

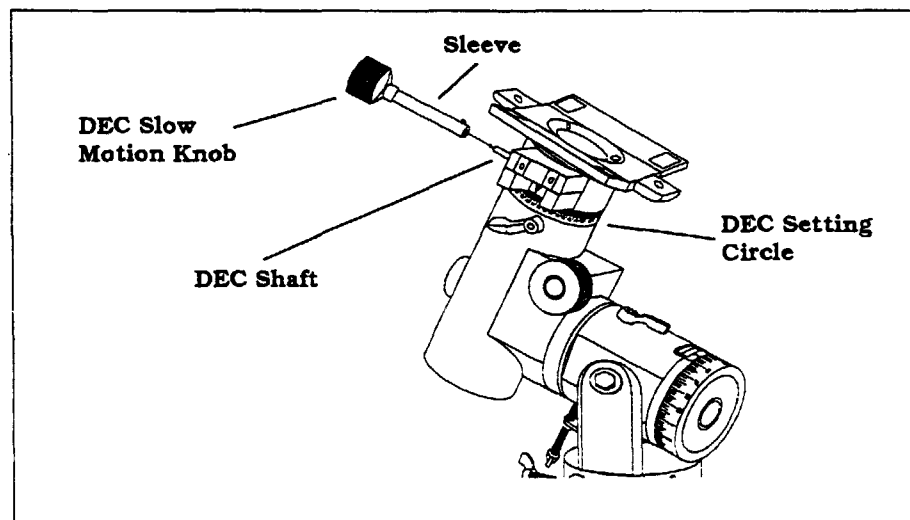

Figure 2-5

Attaching the R.A. Slow Motion Knob

On either side of the mount, just below the DEC setting circle, there are two shafts that extend out about 1/2". These are the R.A. shafts (see figure 2-7). The R.A. slow motion knob has a small metal sleeve that fits over the R.A. shaft. To install the R.A. slow motion knob:

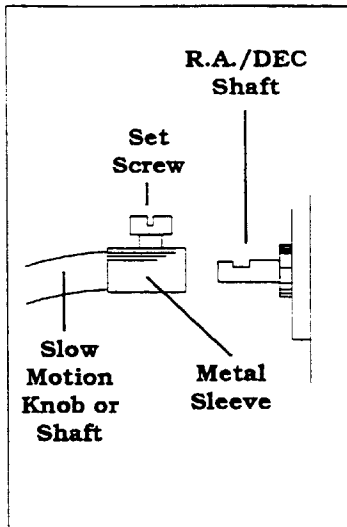

Figure 2-6

Attaching the R.A. and DEC Slow Motion Knobs.

1. Loosen the set screw on the R.A. slow motion knob until the tip of the screw no longer extends into the inner diameter of the sleeve. You will need a standard flat-blade screwdriver (or an Allen wrench) for this task.
2. Orient the metal sleeve so that the set screw is over the flat portion of the R.A. shaft (see figure 2-6).
3. Slide the metal sleeve on the R.A. slow motion knob over R.A. shaft (see figure 2-7).
4. Tighten the set screw to hold the R.A. slow motion knob firmly in place.

As mentioned above, there are two R.A. shafts, one on either side of the mount. It makes no difference which shaft you put it on since both work the same. Use whichever one you find more convenient. If, after a few observing sessions, you find the R.A. slow motion knob is more accessible from the other side, go ahead and move it.

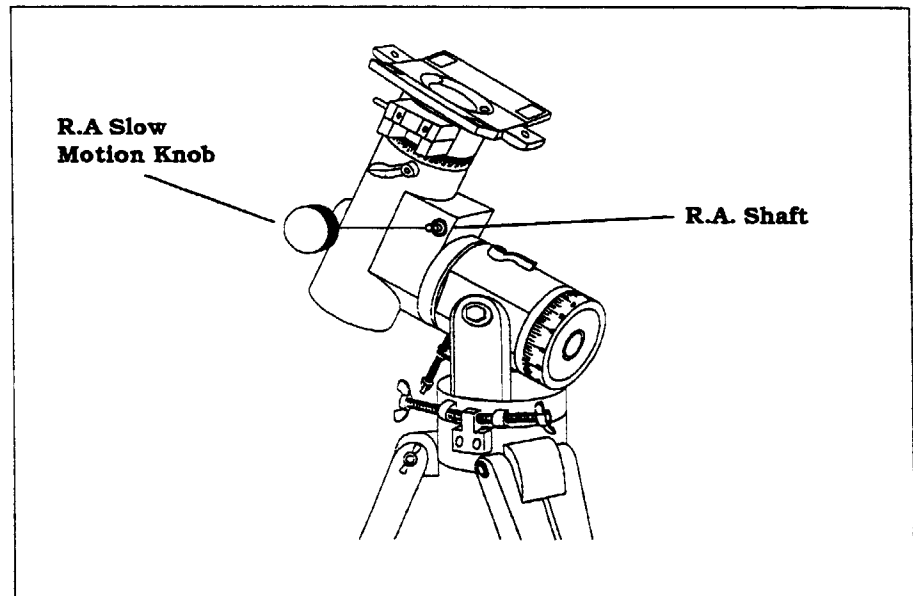

Figure 2-7

Attaching the Counterweight Bar

Used to balanced the telescope, the counterweight bar attaches to the opposite side of the mount as the telescope. To install the counterweight bar:

1. Retract the counterweight bar lock nut by turning it counterclockwise. This will expose the threads on the end of the counterweight bar.
2. Thread the counterweight bar into the mount completely. Once again, it threads into the mount opposite the telescope mounting platform (see figure 2-8).
3. Tighten the lock nut fully for added support.

The counterweight bar is now installed. The counterweight is installed and needs only be adjusted for proper balance. For more information, see the section on "Balancing the Telescope in R.A."

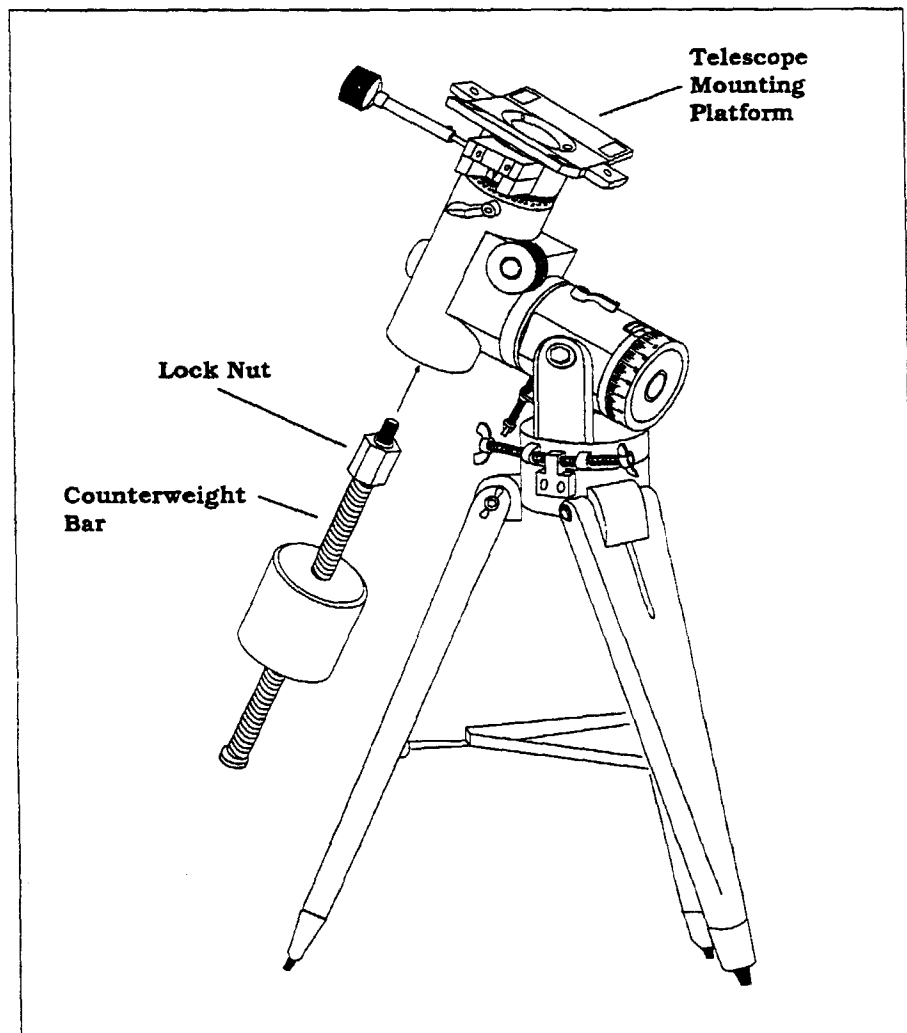

Figure 2-8

Attaching the Telescope to the Mount

Before you attach the optical tube, make sure that the declination and right ascension clamps are tight. The optical tube attaches to the mount via two rings that are mounted on the telescope tube. To mount the telescope tube:

1. Loosen the knobs on the side of the mounting rings. This allows you to slide the mounting rings the length of the optical tube.
2. Slide the mounting rings apart so that each is toward a different end of the telescope. Ideally, the mounting rings should be slightly farther apart than the length of the mounting platform.
3. Orient it so that the finder is on the higher end of the tube pointing up (see figure 2-9).
4. Place the telescope tube on the mount.
5. Slide the rings together until the square extrusions on the rings slide completely over the tabs on the end of the mounting platform.
6. Tighten the mounting knobs on the square extrusions of the mounting rings.
7. Tighten the knobs on the side of the mounting rings to prevent the telescope from sliding forward or backwards. These can be loosened later to reposition the telescope during the DEC balancing process.

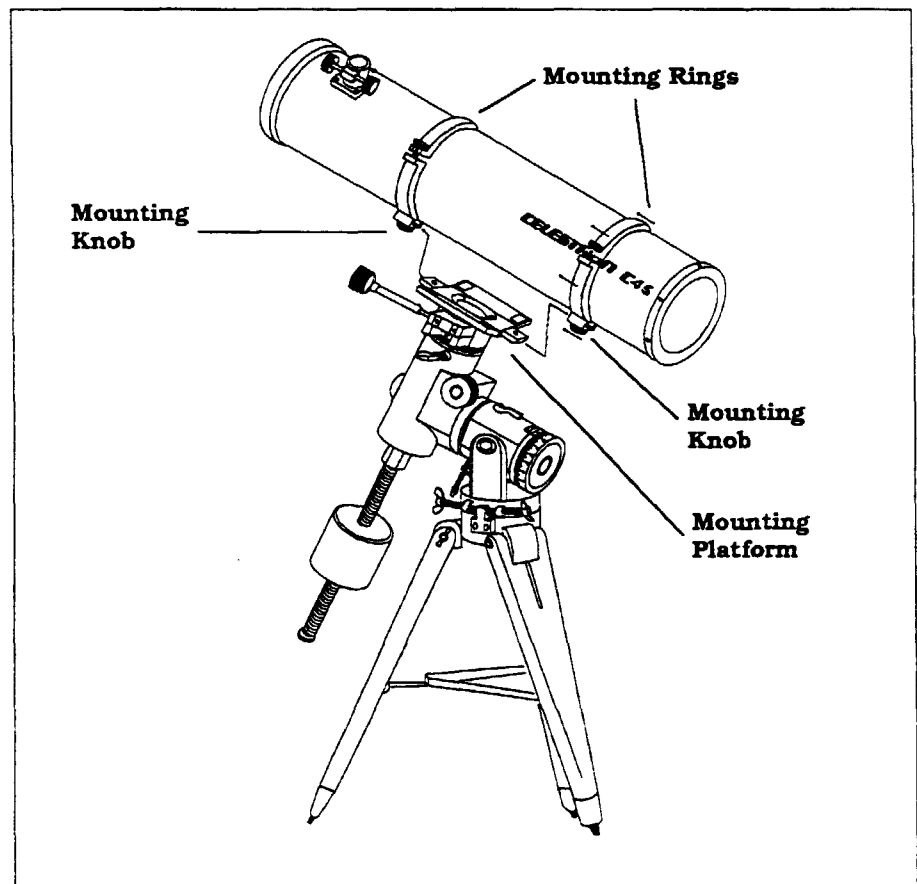

Figure 2-9

Installing the Eyepiece

The eyepiece, or ocular as it is also called, is an optical element that magnifies the image focused by the telescope. Without the eyepiece it would be impossible to use the telescope visually. The eyepiece fits directly into the eyepiece holder. To attach an ocular:

1. Loosen the set screw on the eyepiece holder so that it does not obstruct the inner diameter of the eyepiece holder.
2. Slide the chrome portion of the eyepiece into the eyepiece holder.
3. Tighten the set screw to hold the eyepiece in place.

To remove the eyepiece, loosen the set screw on the eyepiece holder and slide the eyepiece out. You can replace it with another ocular.

Eyepieces are commonly referred to by focal length which is printed on the eyepiece barrel. The longer the focal length (i.e., the larger the number) the lower the eyepiece power and the shorter the focal length (i.e., the smaller the number) the higher the magnification. Generally, you will use low-to-moderate power when viewing. For more information on how to determine power, see the section on "Calculating Magnification."

In addition, eyepieces are also referred to by barrel diameter. The C4.5 uses eyepieces with a barrel diameter of 1-1/4".

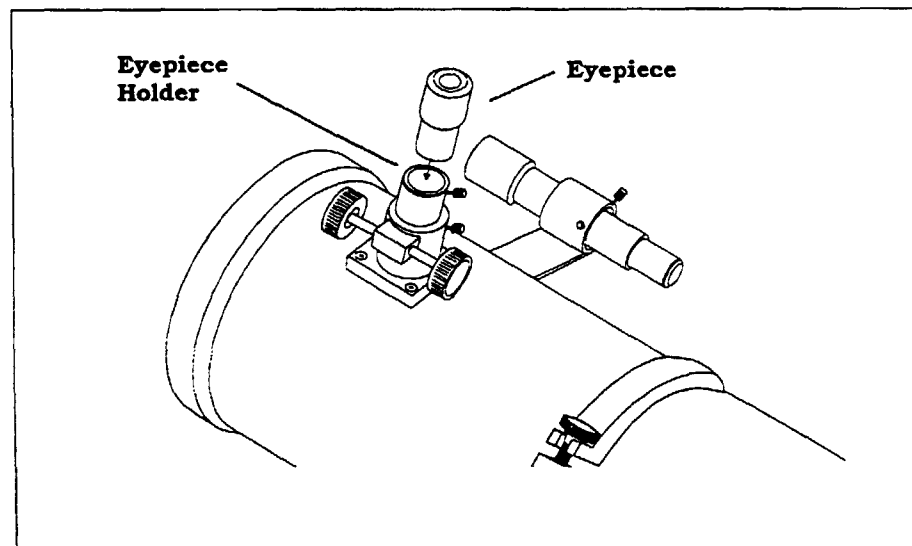

Figure 2-10

Disassembling and Transporting Your C4.5

Once assembled, your C4.5 telescope can be left set up. The entire unit is light enough to pick up and carry outside for a casual observing session. If, however, you want to transport your C4.5 to a remote observing location, you must partially disassemble your telescope. To do so:

1. Remove the optical tube from the equatorial mount.
2. Wrap the tube in cloth to prevent it from being scratched or dented.
3. Remove the three wing nuts that hold the accessory tray to the tripod and pull the tray off of the bracket.
4. Thread the wing nuts back onto the accessory tray to ensure that they do not get lost.
5. Fold the tripod legs together and you are ready to transport your C4.5 telescope.

NOTE: The equatorial mount does NOT have to be removed from the tripod if you are transporting the telescope yourself. However, you may want to remove the counterweight bar to lighten the mount.

If you are shipping your telescope via a common carrier, you should completely disassemble the telescope and return all parts to their original shipping container.

Storing Your C4.5

When not in use, your Celestron C4.5 can be left fully assembled and set up. However, all telescope, finder, and eyepiece covers should be put back in place. This will reduce the amount of dust build-up on the optical surfaces and reduce the number of times you need to clean the instrument. If you decide you want to return everything to its original shipping container and store the parts there, you should still cover all optical surfaces to prevent dust build-up.

To prevent the tripod legs from warping, keep them oiled with a lemon oil. Also, when storing the tripod in the original shipping container, make sure that all the bolts are completely tightened.

Technical Specifications

Below is pertinent technical information on your C4.5 telescope that you may find useful.

Optical System:	Newtonian Reflector
Aperture:	114mm (4.5")
Focal Length:	900mm (35.4")
Near Focus	
with eyepiece:	95'
with camera:	35'
Highest Useful Power:	270x
Resolution (arc seconds):	1.01'
Light Gathering Power:	265x
Limiting Visual Magnitude:	12.8
Secondary Obstruction	1-1/16"
% of Primary Surface Area	7.7%
f/ratio:	f/7.9
Length:	31.5"
Weight	
Optical Tube:	7 lb.
With Tripod:	28 lb.

Note: All specifications are stated for the C4.5 telescope using the standard accessories. These specifications are approximate and subject to change without notice.

B A S I C O P E R A T I O N

With your C4.5 telescope fully assembled, take time to familiarize yourself with its basic operation. This should be done indoors where it is easier to find knobs and clamps. This will make your first observing session under the stars more enjoyable.

Moving the Telescope in R.A. and DEC

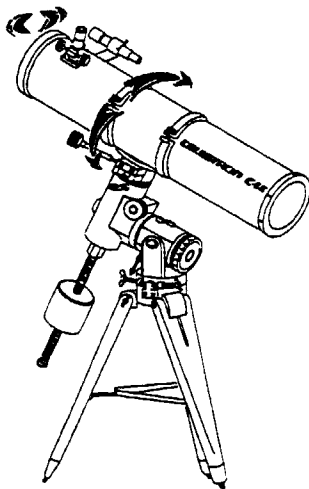

Figure 3-1

To change the direction the telescope is pointing, the C4.5 can be moved in two axes; east/west which is known as the right ascension (R.A.) and north/south which is called declination (DEC). Figure 3-1 shows the appropriate motion of each axis.

For major changes in the direction the telescope is pointing (not the mount):

1. Loosen the R.A. and/or DEC clamps (see figure 3-2).
2. Move the telescope so that it is pointing in the desired direction. Notice that as you move the telescope, the mount always points in the same direction.
3. Tighten the R.A. and DEC clamps to hold the telescope in place.

For fine adjustments needed to center an object, turn the R.A. and DEC slow motion knobs. If you are using the optional motor drive, the telescope will track in right ascension.

The R.A. setting circle reads in minutes and is incremented at 10-minute intervals. The hour of R.A. is printed above the appropriate mark. The declination setting circle reads in degrees and is incremented in 2 degree intervals. For more information, please see the section on "Using the Setting Circles."

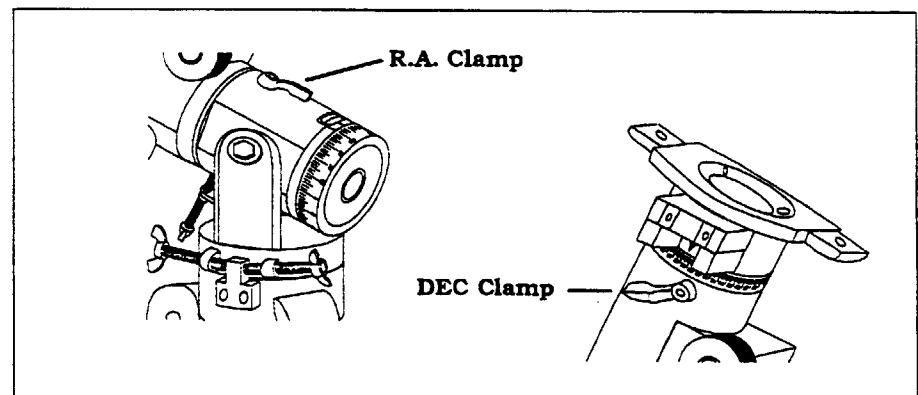

Figure 3-2

Balancing the Telescope in R.A.

To eliminate undue stress on the mount, the telescope should be properly balanced around the R.A. axis (also known as the polar axis.) In addition, proper balancing is crucial for accurate tracking if using the optional clock drive. To balance the mount:

1. Release the R.A. Clamp and position the telescope off to one side of the mount (see figure 3-3).
2. **GRADUALLY** release the telescope to see which way it "rolls."
3. Thread the counterweight up or down the shaft to a point where it balances the telescope (i.e., the telescope remains stationary when the R.A. clamp is released).

When this is done, the scope is properly balanced in right ascension.

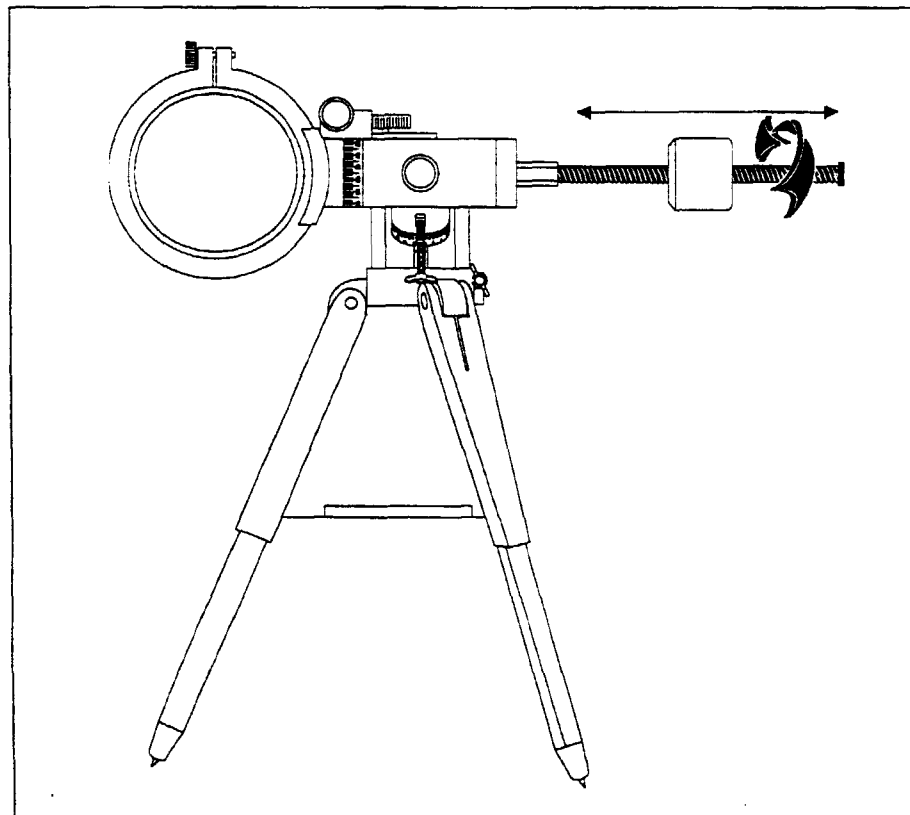

Figure 3-3

Balancing the Telescope in DEC

The telescope should also be balanced in declination to prevent any sudden motions when the DEC clamp is released. To balance the telescope in Declination:

1. Release the R.A. clamp and rotate the telescope so that it is on one side of the mount (i.e., as described in the previous section on balancing the mount in R.A.).
2. Lock the R.A. clamp to hold the telescope in place.
3. Release the DEC clamp and position the telescope so that it is parallel to the ground.
4. GRADUALLY release the telescope tube to see which way it "rolls."
5. Loosen the knobs that hold the telescope inside the mounting rings and slide the telescope either forward or backward until it remains stationary when the DEC clamp is released (see figure 3-4).
6. Tighten the knobs that hold the telescope in the mounting rings.

The telescope is now properly balanced in declination.

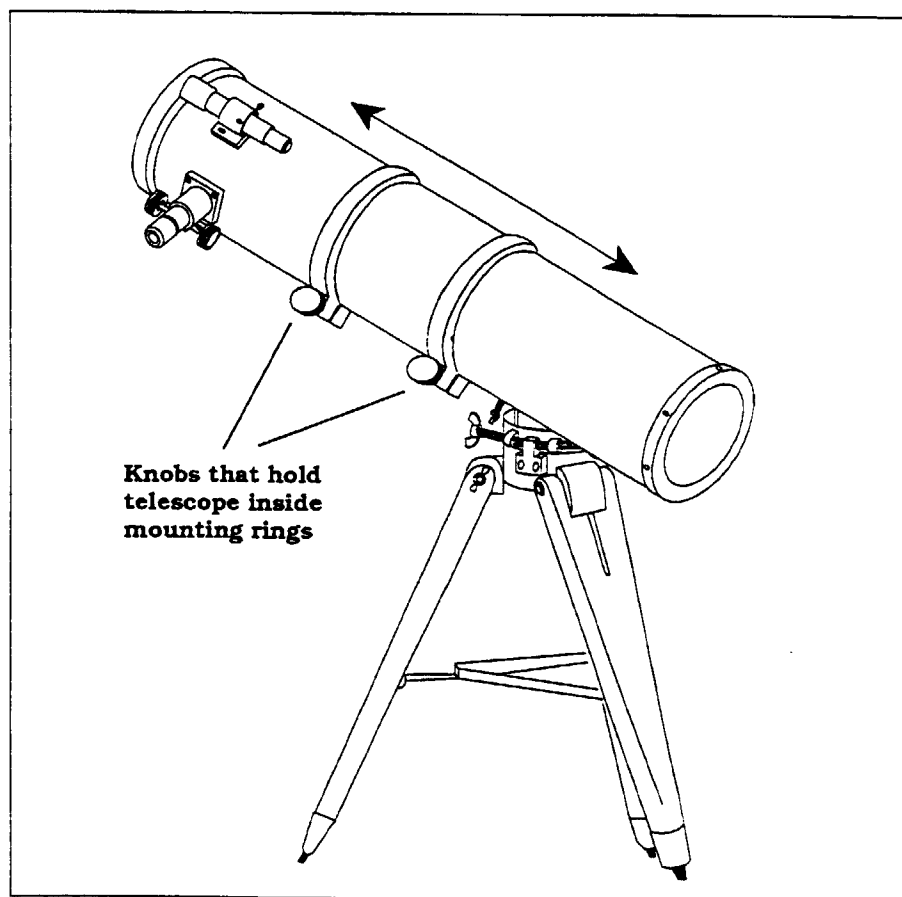

Figure 3-4

Adjusting the Mount

In order to follow objects easily, the telescope's axis of rotation (i.e., the R.A. axis) must be parallel to the Earth's axis. The process of doing so is known as polar alignment and discussed later in this manual. This section simply covers the correct movement of the telescope during the polar alignment process. For the purpose of polar alignment, there are two directions in which the telescope mount can be adjusted; vertically, which is called altitude and horizontally, which is called azimuth (see figure 3-5). To adjust the altitude of the mount (i.e., raise or lower the angle of the polar axis):

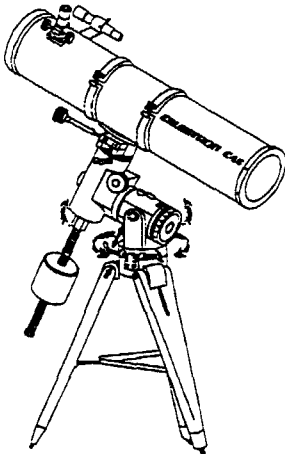

Figure 3-5

1. Loosen the altitude tension clamp on the side of the mount.
2. Turn the altitude adjustment screw underneath the mount (see figure 3-6). Turning the screw clockwise raises the mount, while turning it counterclockwise lowers the mount.
3. Tighten the altitude tension clamp to hold the mount in place when at the desired position. The right position is when the mount is pointing at Polaris.

For an initial setting, adjust the mount until the latitude indicator points to the correct latitude of your observing site.

To adjust the mount in azimuth (i.e., move the polar axis horizontally):

1. Turn the azimuth adjustment screws located on the side of the mount (see figure 3-6). While standing behind the telescope, the knobs are on the left side of the mount.
 - Turning the front adjustment screw clockwise moves the mount toward the left.
 - Turning the back adjustment screw clockwise moves the mount to the right.

Since both of these screws push off of a peg on the tripod head, they produce opposing forces. In other words, you will have to loosen one screw while tightening the other. These screws are used for fine adjustments of the mount during the polar alignment process. For rough adjustments, pick up the telescope and tripod and re-orient it.

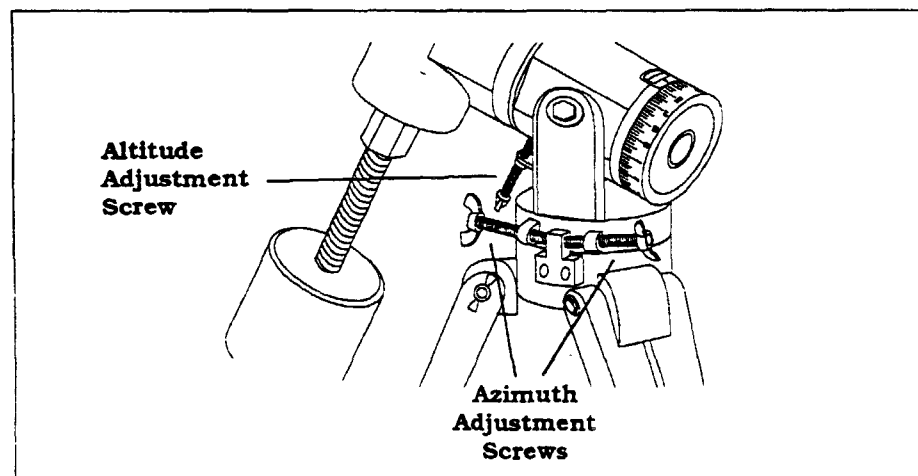

Figure 3-6

GETTING STARTED

As with any optical instrument, there are several things you must know about your C4.5 telescope to get the most out of it. This section deals with basic information and initial use.

Image Orientation

The Newtonian optical system produces an inverted image (i.e., upside down and backwards). Unfortunately, there is no accessory that reinverts the images to match the orientation seen by the unaided human eye. However, this will only affect your terrestrial observations. For celestial viewing, star charts can be made to match the view in the telescope simply by rotating the chart 180° about the center. This orientation applies to the telescope's finder as well.

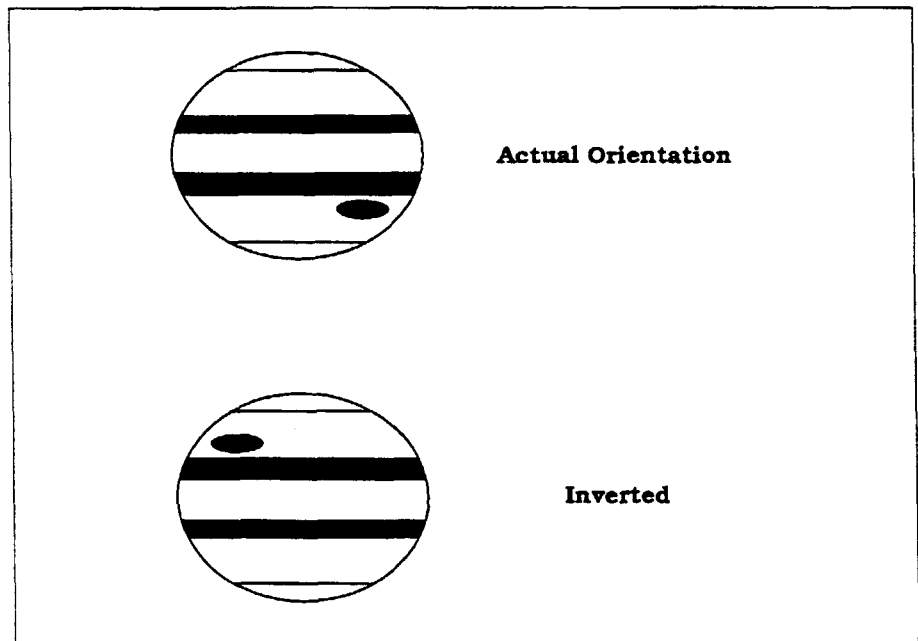

Figure 4-1

The planet Jupiter is used to illustrate the image orientation of the C4.5. Top is the actual orientation while below is an inverted image. Both the C4.5 and its finder produce inverted images.

Focusing

To focus your telescope, simply turn either of the focus knobs located directly below the eyepiece holder (see figure 4-2). Turning the knobs clockwise allows you to focus on an object that is farther than the one you are currently observing. Turning the knob counterclockwise from you allows you to focus on an object closer than the one you are currently observing.

In addition to understanding how the focusing mechanism works, there are a few focusing hints that should be remembered when using any optical instrument.

- Never try to look through glass. Glass found in household windows may vary in thickness from one location to the next, and as a result, is optically imperfect. This inconsistency can and will affect the ability to focus your telescope. In most cases you will not be able to achieve a truly sharp focus. In some cases, you may actually see a double image.
- Never look across or over objects that are producing heat waves. This includes asphalt parking lots on hot summer days or building roof tops.
- Hazy skies, fog and mist can also make it difficult to focus. The amount of detail that can be seen under these conditions will be greatly reduced.
- When using your telescope as a telephoto lens, the split screen focuser of the 35mm camera may "black out." This is common with all long focal length lenses. If this does happen, use the ground glass portion of your focusing screen. To achieve a very sharp focus, consider using a focusing magnifier. (These are readily available from your local camera store.)
- If you wear corrective lenses (specifically glasses), you may want to remove them when observing with an eyepiece attached to the telescope. However, when using a camera you should always wear corrective lenses to ensure the sharpest possible focus. If you have astigmatism, corrective lenses must be worn at all times.

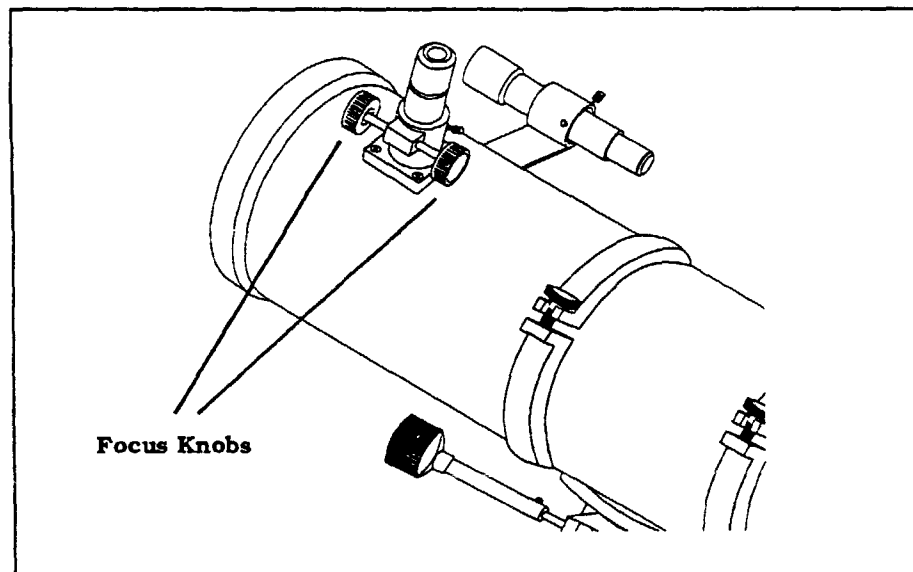

Figure 4-2

Aligning the Finder

Accurate alignment of the finder makes it easy to find objects with the telescope, especially celestial objects. Your finder comes installed and aligned, so there is no need for you to make any changes unless it becomes misaligned. To make aligning the finder as easy as possible, this procedure should be done in the daytime when it is easy to find and identify objects in the telescope without the aid of the finder. To align the finder:

1. Choose a target that is in excess of one mile away. This will eliminate any possible parallax effect between the telescope and finder.
2. Release the R.A. and DEC clamps and point the telescope at your target.
3. Lock the clamps once pointed in the general direction.
4. Center your target in the main optics of the telescope using the R.A. and DEC slow motion knobs.
5. Adjust the thumbscrews on the finder bracket, tightening one while loosening another, until the cross hairs are centered on the target seen through the telescope.
6. Tighten each thumbscrew a quarter of a turn to ensure that they do not come loose easily.

Since the image orientation through the finder is inverted (i.e., upside down and backwards left-to-right), it may take a few minutes to familiarize yourself with the directional change each thumbscrew makes on the finder.

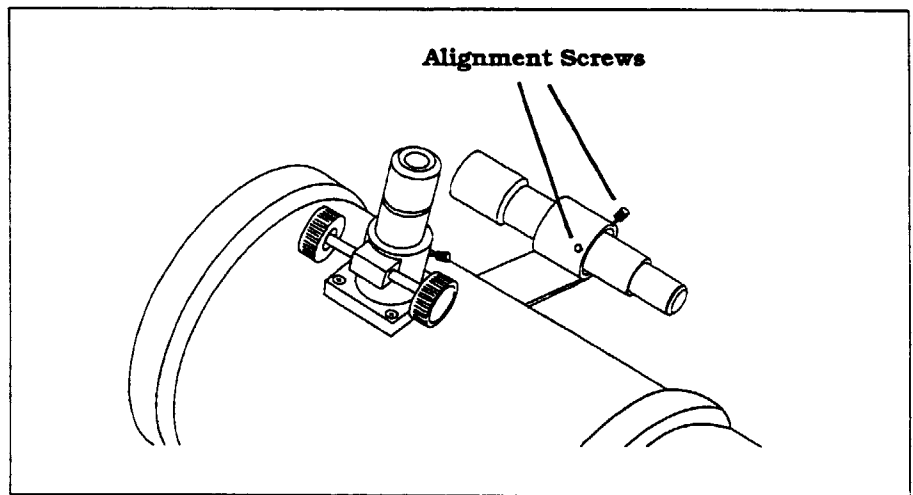

Figure 4-3

Your First Look

With the telescope fully assembled and all the accessories attached you are ready for your first look. Your first look should be done in the daytime when it will be easier to locate the locking clamps and slow motion adjustment knobs. This will help to familiarize you with your telescope, thus making it easier to use at night.

Daytime Observing

To use your C4.5 in the daytime:

WARNING !

NEVER POINT YOUR TELESCOPE AT THE SUN UNLESS YOU HAVE THE PROPER SOLAR FILTER. PERMANENT AND IRREVERSIBLE EYE DAMAGE MAY RESULT AS WELL AS DAMAGE TO YOUR TELESCOPE. ALSO, NEVER LEAVE YOUR TELESCOPE UNATTENDED DURING A DAYTIME OBSERVING SESSION, ESPECIALLY WHEN CHILDREN ARE PRESENT.

1. Find a distant object that is fairly conspicuous.
2. Insert a low power eyepiece (one with a large focal length) into the telescope.
3. Release the R.A. and DEC clamps and point the telescope at the object you selected.
4. Locate the object in your finder.
5. Lock the R.A. and DEC clamps.
6. Use the slow motion knobs to center the object in the field of the finder.
7. Once centered, look through the main optics and the object will be there (if you aligned the finder first).

Try using different eyepieces to see how the field changes with various magnifications. Keep in mind that the image viewed through your C4.5 is inverted. As a result, it is not as desirable for terrestrial viewing. This type of viewing session is primarily to familiarize yourself with the basic operation of your C4.5 before using it under dark skies.

Nighttime Observing

Looking at objects in the sky is quite different than looking at objects on Earth. For one, many objects seen in the daytime are easy to see with the naked eye and can be located by using landmarks. In the night sky many objects you observe are not visible to the naked eye. Finding these objects is discussed later in the section on "Visual Observing." For your first look, choose something bright like the Moon or one of the naked-eye planets.

1. Orient the telescope so that the polar axis is pointing as close to true north as possible. You can use a landmark that you know faces north to get you in the general direction.
2. Make sure the mount is level.
3. Adjust the mount until the latitude indicator points to the latitude from which you are observing.
4. Insert an eyepiece into the telescope. It should be a low power eyepiece (i.e., one with a large number on the side) to give you the widest field possible.
5. Turn the clock drive on (if using the optional motor drive).
6. Release the right ascension and declination clamps and point the telescope at the desired target. The Moon or one of the brighter planets is an ideal first target.
7. Locate the object in the finder and center it.
8. Look through the telescope.
9. Turn the focus knob until the image is sharp.
10. Take your time and study your subject. If looking at the Moon, look for small detail in the craters.

That's all there is to using your Celestron C4.5. However, don't limit your view of an object to a single eyepiece. After observing an object for a few minutes, try using a different eyepiece, perhaps a more powerful one. This gives you an idea of how the field of view changes. Center your target and focus. Once again, if looking at the Moon you will be looking at a few craters at one time. Use the slow motion knobs to scan the lunar surface.

NOTE: If not using the clock drive, the stars will appear to drift out of the field of view. This is due to the Earth's rotation. In fact, anything in the sky, day or night, will drift out of the field unless the telescope has been polar aligned and the clock drive is running. More on this in the section on "Polar Alignment."

Calculating Magnification

You can change the power of your Celestron C4.5 just by changing the eyepiece (ocular). To determine the magnification for your C4.5, simply divide the focal length of the telescope by the focal length of the eyepiece you are using. In equation format, the formula looks like this:

$$\text{Magnification} = \frac{\text{Focal Length of Telescope (mm)}}{\text{Focal Length of Eyepiece (mm)}}$$

Let's say, for example, that you are using a 12.5mm eyepiece. To determine the magnification, simply divide the focal length of your C4.5 (900mm) by the focal length of the eyepiece (12.5mm). This yields a magnification of 72 power.

Although the power is variable, each instrument — under average skies — has a limit to the highest useful magnification. The general rule is that 60 power can be used for every inch of aperture. For example, the C4.5 is 4.5" in diameter. Multiplying 4.5 by 60 gives a maximum useful magnification of 270 power. Although this is the maximum useful magnification, most observing is done in the range of 20 to 35 power for every inch of aperture which is 90 and 135 times for the C4.5.

Determining Field of View

Determining the field of view is important if you want to get an idea of the angular size of the object you are observing. To calculate the actual field of view, divide the apparent field of the eyepiece (supplied by the eyepiece manufacturer) by the magnification. In equation format, the formula looks like this:

$$\text{True Field} = \frac{\text{Apparent Field of Eyepiece}}{\text{Magnification}}$$

As you can see, before determining the field of view you must first calculate the magnification. Using the example we started with above, we can determine the field of view using the same 12.5mm eyepiece. The 12.5mm Ultima eyepiece has an apparent field of view of 51°. Divide the 51° by the magnification, which is 72 power. This yields an actual field of 0.7°, or almost three-quarters of a degree.

This formula gives you the true field of view in degrees. To convert degrees to feet at 1,000 yards, which is more commonly used for terrestrial viewing, simply multiply by 52.5. Continuing with our example, multiply the angular field of .7° by 52.5 produces a linear field width of 36.7 feet at a distance of one thousand yards.

The apparent field of each eyepiece that Celestron manufactures is found in the Celestron accessory catalog (#93685).

ASTRONOMY BASICS

Up to this point, this manual covered the assembly and basic operation of your C4.5 telescope. However, to use your telescope effectively, you need to know a little about the night sky. This section deals with observational astronomy in general and includes information on the night sky and polar alignment.

The Celestial Coordinate System

To help find objects in the sky, astronomers use a celestial coordinate system that is similar to our geographical coordinate system here on Earth. The celestial coordinate system has poles, lines of longitude and latitude, and an equator. For the most part, these remain fixed against the background stars.

The celestial equator runs 360 degrees around the Earth and separates the northern celestial hemisphere from the southern. Like the Earth's equator, it bears a reading of zero degrees. On Earth this would be latitude. However, in the sky this is referred to as declination, or DEC for short. Lines of declination are named for their angular distance above and below the celestial equator. The lines are broken down into degrees, minutes of arc, and seconds of arc. Declination readings south of the equator carry a minus sign (-) in front of the coordinate and those north of the celestial equator are either blank (i.e., no designation) or preceded by a plus sign (+).

The celestial equivalent of longitude is called Right Ascension, or R.A. for short. Like the Earth's lines of longitude, they run from pole to pole and are evenly spaced 15 degrees apart. Although the longitude lines are separated by an angular distance, they are also a measure of time. Each line of longitude is one hour apart from the next. Since the Earth rotates once every 24 hours, there are 24 lines total. As a result, the R.A. coordinates are marked off in units of time. It begins with an arbitrary point in the constellation of Pisces designated as 0 hours, 0 minutes, 0 seconds. All other points are designated by how far (i.e., how long) they lag behind this coordinate after it passes overhead moving toward the west.

Your Celestron C4.5 telescope comes equipped with setting circles that translate the celestial coordinates into a precise location for the telescope to point. The setting circles will not work properly until you have polar aligned the telescope and aligned the R.A. setting circle.

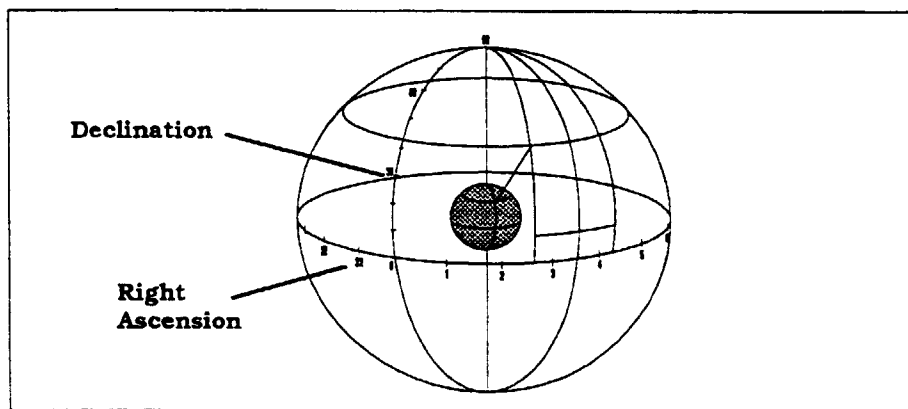

Figure 5-1

The celestial sphere seen from the outside showing R.A. and DEC.

Motion of the Stars

The daily motion of the Sun across the sky is familiar to even the most casual observer. This daily trek is not the Sun moving as early astronomers thought, but the result of the Earth's rotation. The Earth's rotation also causes the stars to do the same, scribing out a large circle as the Earth completes one rotation. The size of the circular path a star follows depends on where it is in the sky. Stars near the celestial equator form the largest circles rising in the east and setting in the west. Moving toward the north celestial pole, the point around which the stars in the northern hemisphere appear to rotate, these circles become smaller. Stars in the mid-celestial latitudes rise in the northeast and set in the northwest. Stars at high celestial latitudes are always above the horizon, and are said to be circumpolar because they never rise and never set. You will never see the stars complete one circle because the sunlight during the day washes out the starlight. However, part of this circular motion of stars in this region of the sky can be seen by setting up a camera on a tripod and opening the shutter for a couple hours. The processed film will reveal semicircles that revolve around the pole. (This description of stellar motions also applies to the southern hemisphere except all stars south of the celestial equator move around the south celestial pole.) The following sections deal with observational astronomy in general. This includes information on the night sky, polar alignment, and using your telescope for astronomical observations.

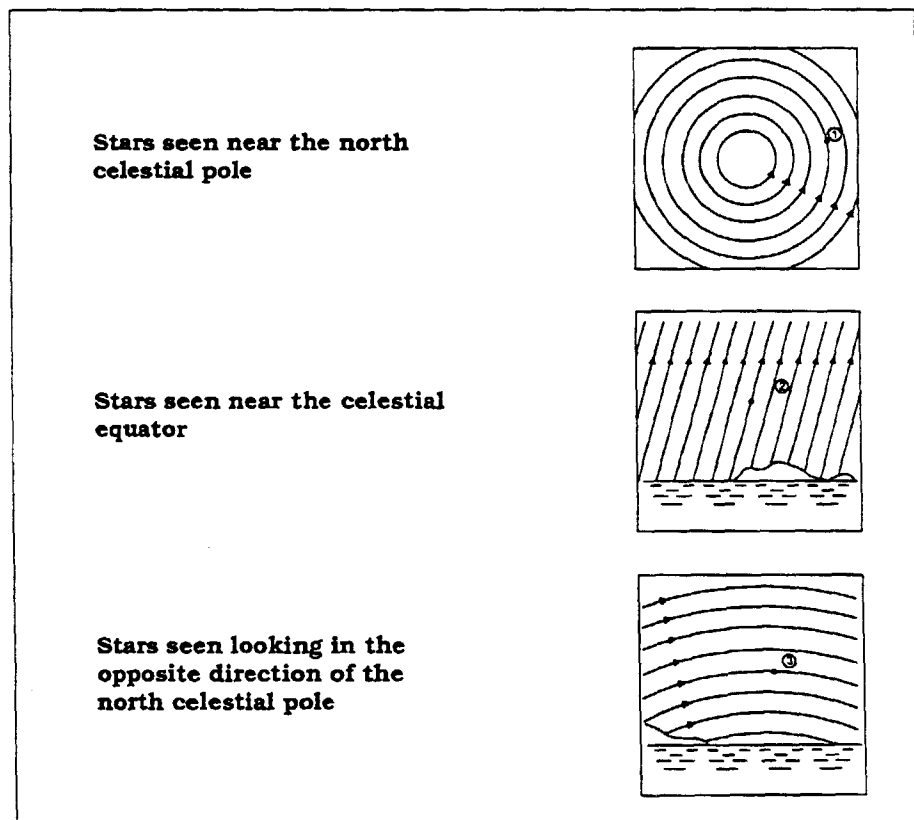

Figure 5-2

All stars appear to rotate around the celestial poles. However, the appearance of this motion varies depending on where you are looking in the sky. Near the north celestial pole the stars scribe out recognizable circles centered on the pole (1). Stars near the celestial equator also follow circular paths around the pole. But, the complete path is interrupted by the horizon. These appear to rise in the east and set in the west (2). Looking toward the opposite pole, stars curve or arc in the opposite direction scribing a circle around the opposite pole (3).

Polar Alignment

In order for the telescope to track the stars you must meet two criteria. First, you need a motor drive that will move at the same rate as the Earth rotates. As an optional accessory, Celestron offers a clock drive that also works as a drive corrector, a device that allows you to override the rate of the motors during astrophotography. The second thing you need is to set the telescope's axis of rotation so that it tracks in the right direction. Since the motion of the stars across the sky is caused by the Earth's rotation about its axis, the telescope's axis must be made parallel to the Earth's.

Polar alignment is the process by which the telescope's axis of rotation (called the polar axis) is aligned (made parallel) with the Earth's axis of rotation. Once aligned, a telescope with a clock drive will track the stars as they move across the sky. The result is that objects observed through the telescope appear stationary (i.e., they will not drift out of the field of view). If not using the clock drive, all objects in the sky (day or night) will slowly drift out of the field. This motion is caused by the Earth's rotation. Even if you are not using the clock drive, polar alignment is still desirable since it will reduce the number of corrections needed to follow an object and limit all corrections to one axis (R.A.). There are several methods of polar alignment, all work on a similar principle, but performed somewhat differently. Each method is considered separately, beginning with the easier methods and working to the more difficult.

Although there are several methods mentioned here, you will never use all of them during one particular observing session. Instead, you may use only one if it is a casual observing session. Or, you may use two methods; one for rough alignment followed by a more accurate method if you plan on doing astrophotography.

Definition:

The polar axis is the axis around which the telescope rotates when moved in right ascension. This axis points the same direction even when the telescope moves in right ascension and declination.

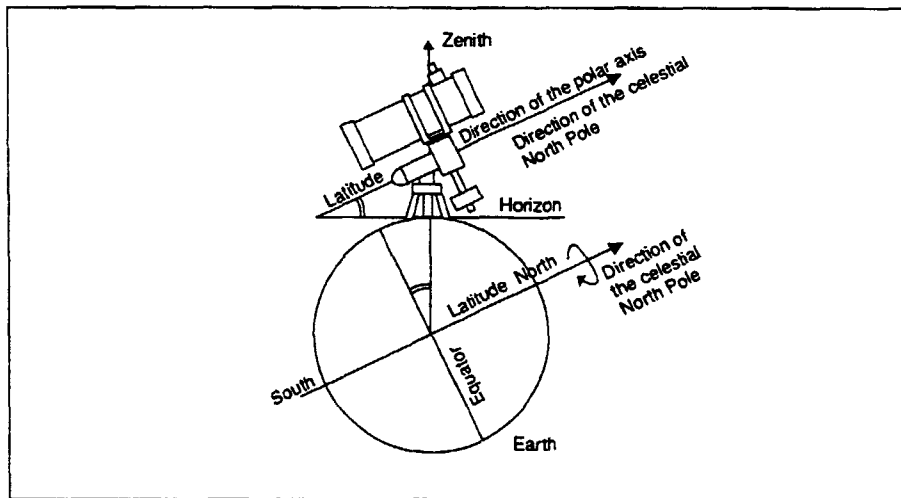

Figure 5-3

When the telescope's axis of rotation (known as the polar or R.A. axis) is parallel to the Earth's axis, stars appear stationary when using the optional clock drive. The process of making the telescope's axis of rotation parallel to the Earth's is described in the section on "Polar Alignment." Once this is done, the telescope is pointed by moving it in R.A. and DEC.

Finding the Pole

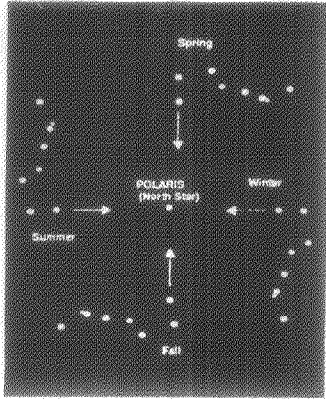

Figure 5-4

The position of the Big Dipper changes throughout the year and throughout the night. This is due to the Earth's motion around the Sun and the Earth's rotation on its axis.

In each hemisphere, there is a point in the sky around which all the other stars appear to rotate. These points are called the celestial poles and are named for the hemisphere in which they reside. For example, in the northern hemisphere all stars move around the north celestial pole. When the telescope's polar axis is pointed at the celestial pole, it is parallel to the Earth's rotational axis.

Many methods of polar alignment require that you know how to find the celestial pole by identifying stars in the area. For those in the northern hemisphere, finding the celestial pole is not too difficult. Fortunately, we have a naked eye star less than a degree away. This star, Polaris, is the end star in the handle of the Little Dipper. Since the Little Dipper (technically called Ursa Minor) is not one of the brightest constellations in the sky, it may be difficult to locate from urban areas. If this is the case, use the two end stars in the bowl of the Big Dipper (the pointer stars). Draw an imaginary line through them toward the Little Dipper. They point to Polaris (see figure 5-5). The position of the Big Dipper changes during the year and throughout the course of the night (see figure 5-4). When the Big Dipper is low in the sky (i.e., near the horizon), it may be difficult to locate. During these times, look for Cassiopeia (see figure 5-5).

Observers in the southern hemisphere are not as fortunate as those in the northern hemisphere. The stars around the south celestial pole are not nearly as bright as those around the north. The closest star that is relatively bright is Sigma Octantis. This star is just within naked eye limit (magnitude 5.5) and lies about 59 arc minutes from the pole. For more information about stars around the south celestial pole, please consult a star atlas.

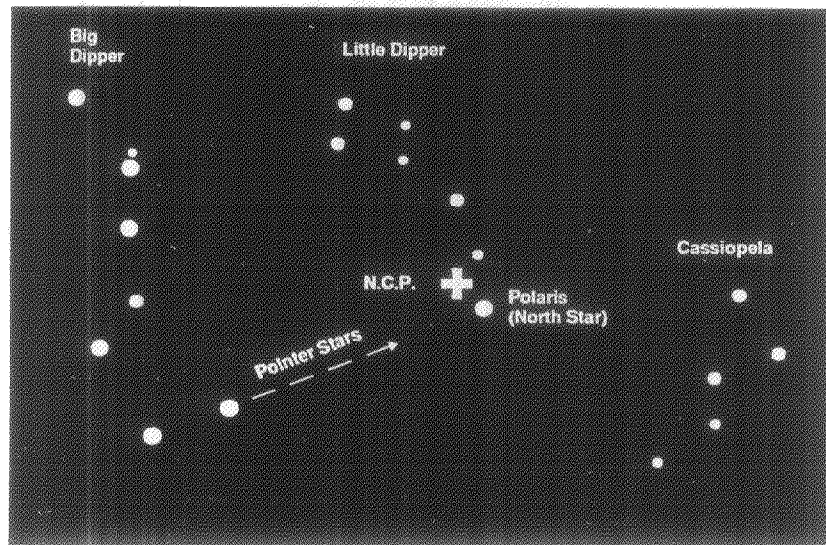

Figure 5-5

The two stars in the front of the bowl of the Big Dipper point to Polaris which is less than one degree from the true (north) celestial pole. Cassiopeia, the "W" shaped constellation is on the opposite side of the pole from the Big Dipper. The North Celestial Pole (N.C.P.) is marked by the "+" sign.

The Latitude Scale

The easiest way to polar align your C4.5 is with the latitude scale. Unlike other methods that require you to find the celestial pole by identifying certain stars near it, this method works using a known constant to determine how high the polar axis should be pointed. The latitude scale for the C4.5 is just above the azimuth adjustment screws (see figure 5-6).

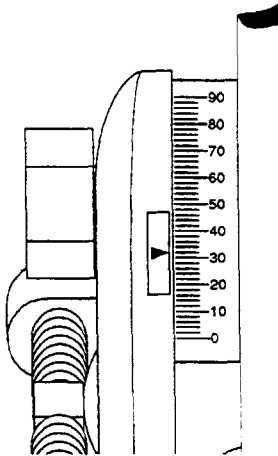

Figure 5-7

While the latitude scale has a range of 0° to 90°, going below 20° will cause the counterweight shaft to hit the tripod.

The constant, mentioned previously, is a relationship between your latitude and the angular distance the celestial pole is above the northern (or southern) horizon. The angular distance from the northern horizon to the north celestial pole is always equal to your latitude. To illustrate this, imagine that you are standing on the north pole, latitude +90°. The north celestial pole, which has a declination of +90°, would be directly overhead, or 90° above the horizon. Now let's say that you move one degree south. Your latitude is now +89° and the celestial pole is no longer directly overhead. It has moved one degree closer toward the northern horizon. This means the pole is now 89° above the northern horizon. If you move one degree further south, the same thing happens again. As you can see from this example, the distance from the northern horizon to the celestial pole is always equal to your latitude.

If you are observing from Los Angeles, which has a latitude of 34°, then the celestial pole would be 34° above the northern horizon. All a latitude scale does then is to point the polar axis of the telescope at the right elevation above the northern (or southern) horizon. To align your telescope using this method:

1. Make sure the R.A. axis (also called the polar axis) is pointing due north. Use a landmark that you know faces north, or you can use a magnetic compass with the local correction for magnetic declination.
2. Make sure that the tripod is level.
3. Move the equatorial head up or down until the latitude indicator points to your latitude (see figure 5-7). For specific information on adjusting the equatorial head, please see the section on "Adjusting the Mount."

This method can be done in daylight, thus eliminating the need to fumble around in the dark. Although this method does NOT put you directly on the pole, it will limit the number of corrections you will make when tracking an object.

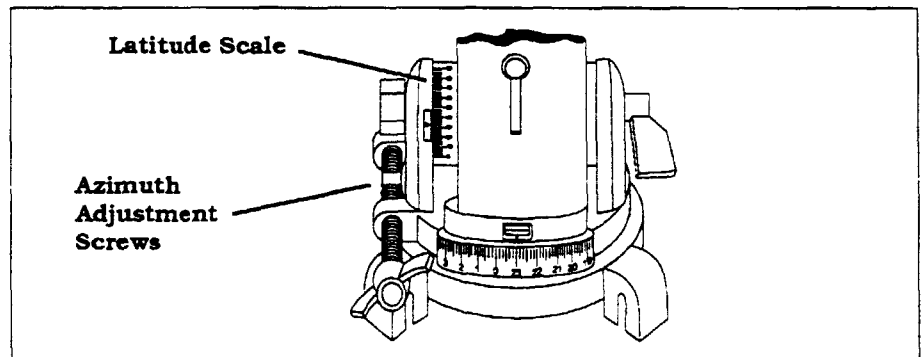

Figure 5-6

Pointing at Polaris

This method utilizes Polaris as a guidepost to the celestial pole. Since Polaris is less than a degree from the celestial pole, pointing the polar axis of the telescope puts you within one degree. Although this is by no means perfect alignment, it is close.

1. Set the telescope up so that the polar axis is pointing north.
2. Release the DEC clamp and move the telescope so that the tube is parallel to the polar axis. When this is done, the declination setting circle will read $+90^\circ$. If the declination setting circle is not aligned, move the telescope so that the tube is parallel to the polar axis (see figure 5-8).
3. Move the mount in altitude and/or azimuth until Polaris is in the field of view of the finder. Rough adjustments in azimuth can be made by moving the tripod.
4. Center Polaris using the altitude and azimuth controls. Remember, do not move the telescope in R.A. and DEC. You want to adjust the direction the polar axis is pointing and you are using the telescope to see where the polar axis is pointing.

Like the previous methods, this gets you close to the pole but not directly on it. The following method will help improve your accuracy for more serious observations and photography.

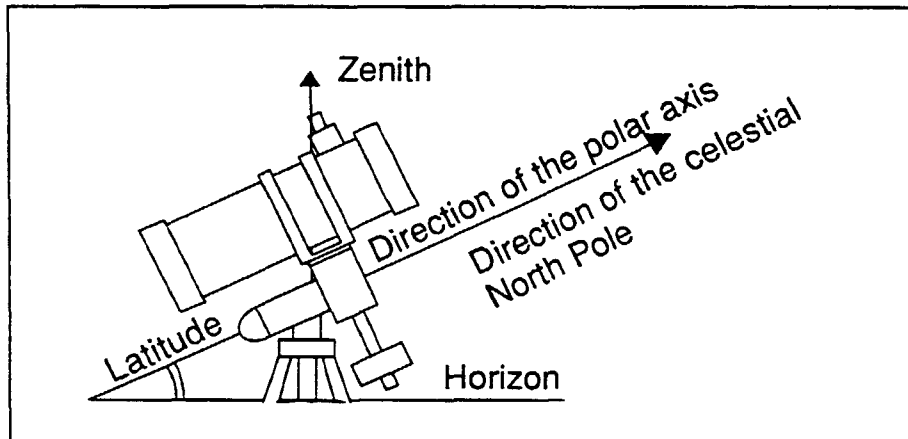

Figure 5-8

One might think that pointing at the pole will produce a parallax effect thus skewing the telescope's axis of rotation with that of the Earth's. Polaris, however, is over 50 light years away, thus making any parallax effect negligible. (One light year is 6.4 trillion miles. To find the distance to Polaris in miles, multiply 6.4 trillion by 50!)

Declination Drift

This method of polar alignment allows you to get the most accurate alignment on the celestial pole and is required if you want to do long exposure deep-sky astrophotography through the telescope. The declination drift method requires that you monitor the drift of selected stars. The drift of each star tells you how far away the polar axis is pointing from the true celestial pole and in what direction. Although declination drift is simple and straightforward, it requires a great deal of time and patience to complete when first attempted. The declination drift method should be done after any one of the previously mentioned methods has been completed.

To perform the declination drift method you need to choose two bright stars. One should be near the eastern horizon and one due south near the meridian. Both stars should be near the celestial equator (i.e., 0° declination). You will monitor the drift of each star one at a time and in declination only. While monitoring a star on the meridian, any misalignment in the east-west direction is revealed. While monitoring a star near the east/west horizon, any misalignment in the north-south direction is revealed. As for hardware, you will need a motor drive, an illuminated reticle ocular to help you recognize any drift. For very close alignment, a Barlow lens is also recommended since it increases the magnification and reveals any drift faster.

Insert the cross hair ocular and align the cross hairs so that one is parallel to the declination axis and the other is parallel to the right ascension axis. Move your C4.5 manually in R.A. and DEC to check parallelism.

First, choose your star near where the celestial equator and the meridian meet. The star should be approximately within 1/2 an hour of the meridian and within five degrees of the celestial equator. Center the star in the field of your telescope and monitor the drift in declination.

- If the star drifts south, the polar axis is too far east.
- If the star drifts north, the polar axis is too far west.

Make the appropriate adjustments to the polar axis to eliminate any drift. Once you have eliminated all the drift, move to the star near the eastern horizon. The star should be 20 degrees above the horizon and within five degrees of the celestial equator.

- If the star drifts south, the polar axis is too low.
- If the star drifts north, the polar axis is too high.

Again, make the appropriate adjustments to the polar axis to eliminate any drift. Unfortunately, the latter adjustments interact with the prior adjustments ever so slightly. So, repeat the process again to improve the accuracy checking both axes for minimal drift. Once the drift has been eliminated, the telescope is very accurately aligned. You can now do prime focus deep-sky astrophotography for long periods.

NOTE:

If the eastern horizon is blocked, you may choose a star near the western horizon, but you must reverse the polar high/low error directions. Also, if using this method in the southern hemisphere, the direction of drift is reversed for both R.A. and DEC.

Aligning the R.A. Setting Circle

In order to align the R.A. setting circle, you must first polar align the mount. Second, you need to know the names of a few bright stars. If you don't, they can be learned by using the Celestron Sky Maps (#93722) or consulting a current issue of an astronomy magazine. To align the R.A. setting circle:

1. Locate a bright star near the celestial equator. The farther you are from the celestial pole the better your reading on the R.A. setting circle will be. The star you choose to align the setting circle with should be a bright one whose coordinates are known and easy to look up. (For a list of bright stars to align the R.A. setting circle, see the list at the back of this manual.)
2. Center the star in the finder.
3. Look through the main telescope and see if the star is in the field. If not, find it and center it.
4. If you purchased the optional clock drive, start it now so that it will track the star.
5. Look up the coordinates of the star.
6. Rotate the R.A. circle until the proper coordinates line up with the R.A. indicator (the zero mark on the vernier scale). The R.A. setting circle should rotate freely.

Once you have finished this process you are ready to use the setting circles to locate objects in the night sky. The declination setting circle is aligned during the process of polar alignment. There is no need to align it in the same manner as the R.A. setting circle. Right ascension is measured in hours and minutes. As a result, the R.A. setting circle is marked off in hours and minutes with markers at 10-minute intervals. The hour of R.A. is printed above the appropriate mark.

Declination is measured in degrees. The Declination setting circle, as a result, is incremented in degrees with a marker every two degrees. Every tenth degree is printed above the appropriate mark.

NOTE: Because the R.A. setting circle does NOT move as the telescope moves in R.A., the setting circle must be aligned each time you want to use it to find an object. This holds true even if you are using the optional clock drive. However, you do not need to use a star each time. Instead, you can use the object you are currently observing.

With your C4.5 set up, you are ready to use it for celestial observing. This section covers visual observing of both solar system and deep-sky objects.

Observing the Moon

In the night sky, the Moon is a prime target for your first look because it is extremely bright and easy to find. Often, it is a temptation to look at the Moon when it is full. At this time, the face we see is fully illuminated and its light can be overpowering. In addition, little or no contrast can be seen during this phase.

One of the best times to observe the Moon is during its partial phases (around the time of first or third quarter). Long shadows reveal a great amount of detail on the lunar surface. At low power you will be able to see all of the lunar disk at one time. Change to higher power (magnification) to focus in on a smaller area. Keep in mind that if you are not using the clock drive, the rotation of the Earth will cause the Moon to drift out of your field of view. You will have to manually adjust the telescope to keep the Moon centered. This effect is more noticeable at higher power.

If you are using the clock drive and have polar aligned, the Moon will remain centered. Consult your local newspaper or a current astronomy magazine to find out when the Moon is visible. Try using filters to increase contrast and bring out more detail on the lunar surface.

Observing the Planets

Other easy targets in the night sky include the five naked eye planets. You can see Venus go through its lunar-like phases. Mars can reveal a host of surface detail and one, if not both, of its polar caps. You will be able to see the cloud belts of Jupiter and the great Red Spot (if it is visible at the time you are observing). In addition, you will also be able to see the moons of Jupiter as they orbit this gas giant. Saturn with its beautiful ring system and Cassini's division are easily visible at moderate power. All you need to know is where to look. Most astronomy publications tell where the planets can be found in the sky each month.

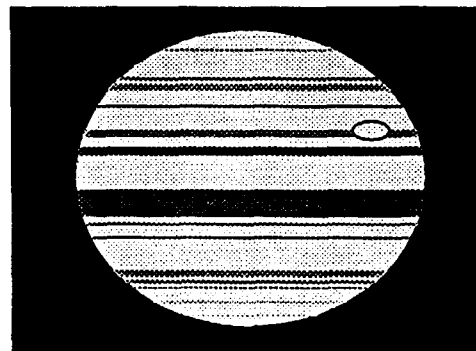

Figure 6-1

This scanned drawing of Jupiter provides a good representation of what you can expect to see with moderate magnification during good seeing conditions. The large, bright cloud belts should be immediately obvious. Smaller, faint belts become visible with practice and experience.

Observing the Sun

Although overlooked by many amateur astronomers, solar observation is both rewarding and fun. However, because the Sun is so bright, special precautions must be taken when observing our star so as not to damage your eyes or your telescope.

WARNING:

Never project an image of the Sun through the telescope. Because of the folded optical design, tremendous heat build-up will result inside the optical tube. This can damage the telescope and/or any accessories attached to the telescope.

For safe solar viewing, use a Celestron solar filter (#94138). This filter reduces the intensity of the Sun's light, making it safe to view. With this filter you can see sunspots as they move across the solar disk and faculae, which are bright patches seen near the Sun's edge. **Be sure to cover the objective lens of the finder or completely remove the finder when observing the Sun. This will ensure that the finder itself is not damaged and that no one looks through it inadvertently.**

SOLAR OBSERVING HINTS

- The best time to observe the Sun is in the early morning or late afternoon when the air is cooler.
- To locate the Sun without a finder, watch the shadow of the telescope tube until it forms a circular shadow on the ground.

Observing Deep-Sky Objects

Deep-sky objects are simply those objects outside the boundaries of our solar system. They include star clusters, planetary nebulae, diffuse nebulae, double stars and other galaxies outside our own Milky Way. Unlike the Sun, Moon, and five major planets, most deep sky objects are not visible to the naked eye. Finding them requires using your setting circles or star hopping to them. Most deep-sky objects have a large angular size. Therefore, low-to-moderate power is all you need to see them. Visually, they are too faint to reveal any color seen in long exposure photographs. Instead, they have a black and white appearance. And, because of their low surface brightness, they should be observed from a dark sky location. Light pollution around large urban areas washes out most nebulae making them difficult, if not impossible, to observe. Light Pollution Reduction filters help reduce the background sky brightness, thus increasing contrast.

Using the Setting Circles

Once the setting circles are aligned you can use them to find any objects with known coordinates.

1. Select an object to observe. Use a seasonal star chart or planisphere to make sure the object you chose is above the horizon. As you become more familiar with the night sky, this will no longer be necessary.
2. Look up the coordinates in an atlas or reference book.
3. Move the telescope in declination until the indicator is pointing at the correct declination coordinate.
4. Move the telescope in R.A. until the indicator points to the correct coordinate (do NOT move the R.A. circle). The telescope will track in R.A. as long as the clock drive is operating and the R.A. clamp is in the locked position.
5. Look through the finder to see if you have located the object.
6. Center the object in the finder.
7. Look in the main optics using a low power eyepiece; the object should be there.
8. Repeat the process for each object observed throughout the observing session.

You may not be able to see fainter objects in the finder. When this happens, gradually sweep the telescope around until the object is visible.

The declination setting circle is scaled in degrees while the R.A. setting circle is incremented in minutes with a marker every tenth minute. As a result, the setting circles will get you close to your target, but not directly on it. Also, the accuracy of your polar alignment will also affect how accurately your setting circles read.

At the end of this manual there is a list of deep-sky objects well within reach of your Celestron C4.5 telescope.

Star Hopping

Another way to find deep sky objects is by star-hopping. Star hopping is done by using bright stars to "guide" you to an object. Here are directions for two popular objects.

The Andromeda Galaxy, M31, is an easy first target. To find M31:

1. Locate the constellation of Pegasus, a large square visible in the fall and winter months.
2. Start at the star in the northeast corner. The star is Alpha (α) Andromedae.
3. Move northeast approximately 7° . There you will find two stars of equal brightness — Delta (δ) and Pi (π) Andromedae — about 3° apart.
4. Continue in the same direction another 8° . There you will find two stars — Beta (β) and Mu (μ) Andromedae — about 3° apart.
5. Move 3° northwest — the same distance between the two star — to the Andromeda galaxy. It is easily visible in the finder.

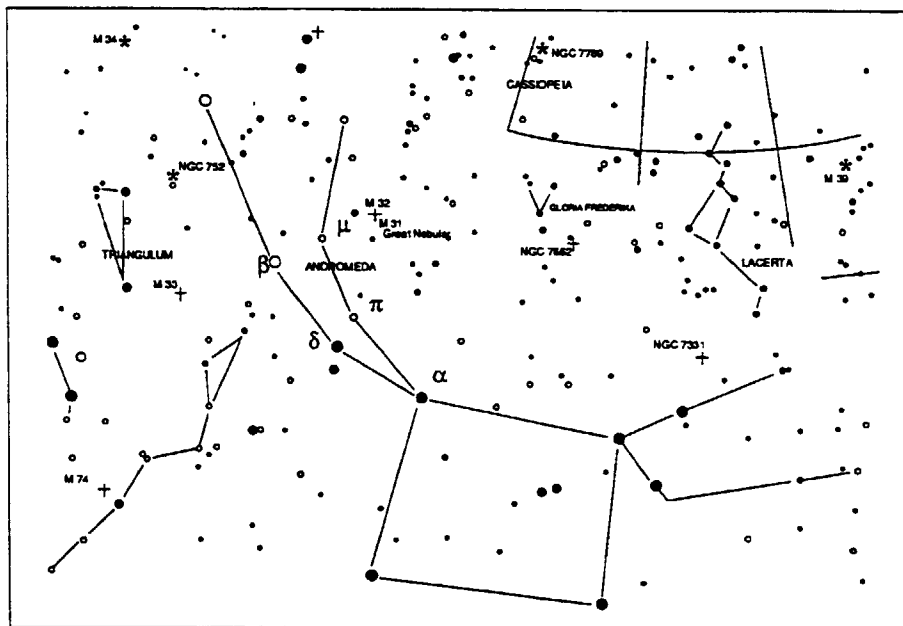

Figure 6-2

Star hopping to the Andromeda Galaxy is a snap to find since all the stars needed to do so are visible to the naked eye. Note that the scale for this star chart is different from the one on the following page which shows the constellation Lyra.

Star hopping may take some getting used to since you can see more stars through the finder than you can see with the naked eye. And, some objects are not visible in the finder. One such object is M57, the famed Ring Nebula. Here's how to find it:

1. Find the constellation of Lyra, a small parallelogram visible in the summer and fall months. Lyra is easy to pick out because it contains the bright star Vega.
2. Start at the star Vega — Alpha (α) Lyrae — and move a few degrees southeast to find the parallelogram. The four stars that make up this geometric shape are all similar in brightness making them easy to see.
3. Locate the two southern most stars that make up the parallelogram — Beta (β) and Gamma (γ) Lyrae (see figure 6-3).
4. Point the finder half way between these two stars.
5. Move about $1/2^\circ$ toward Beta (β) Lyrae, but remaining on a line that connects the two stars.
6. Look through the telescope and the Ring Nebula should be in the telescope. Its angular size is quite small and, therefore, not visible in the finder.

Because the Ring Nebula is rather faint, you may need to use averted vision to see it. Averted vision is the act of looking slightly away from the object you are observing. So, if you are observing the Ring Nebula, center it in the field of view and then look off toward the side. In this manner, light from the object is falling on the black and white sensitive rods as opposed to the color sensitive cones. These two examples should give you an idea of how to star hop to deep sky objects. To use this method on other objects, consult the Celestron Sky Maps (#93722) or any of the various star atlases and star hop to the object of your choice using naked eye stars.

Figure 6-3

Although the Ring Nebula lies between two naked eye stars, it may take a little time to locate since it is not visible in the finder. Note that the scale for this star chart is different from the one on the previous page which shows several constellations including Pegasus, Triangulum, and Andromeda.

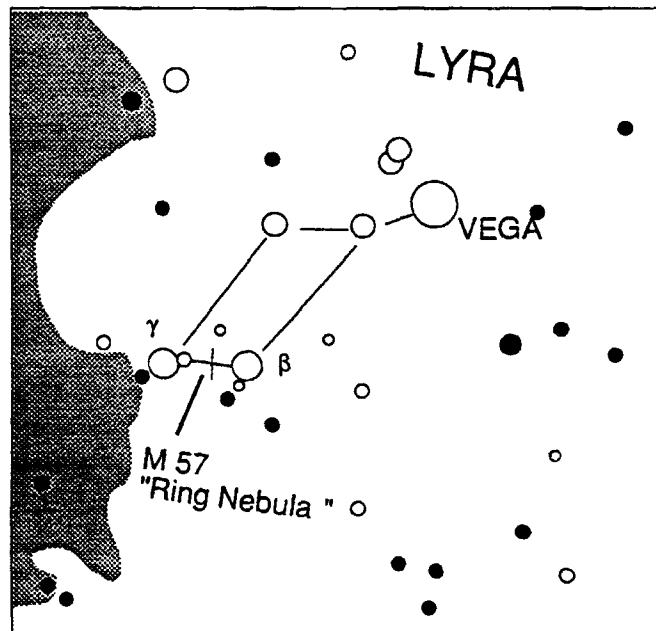

Viewing Conditions

Viewing conditions affect what you can see through your C4.5 telescope during an observing session. Conditions include transparency, sky illumination, and seeing. Understanding viewing conditions and the affect they have on observing will help you get the most out of your C4.5 telescope.

Transparency

Transparency is the clarity of the atmosphere and is affected by clouds, moisture, and other airborne particles. Thick cumulus clouds are completely opaque while cirrus can be thin, allowing the light from the brightest stars through. Hazy skies absorb more light than clear skies making fainter objects harder to see and reducing contrast on brighter objects. Aerosols ejected into the upper atmosphere from volcanic eruptions also affect transparency. Ideal conditions are when the night sky is inky black.

Sky Illumination

General sky brightening caused by the Moon, aurorae, natural airglow, and light pollution greatly affect transparency. While not a problem for the Moon, planets, and brighter stars, bright skies reduce the contrast of extended nebulae making them difficult, if not impossible, to see. To maximize your observing, limit deep sky viewing to moonless nights far from the light polluted skies found around major urban areas. LPR filters enhance deep sky viewing from light polluted areas by blocking unwanted light while transmitting light from certain deep sky objects. You can, on the other hand, observe planets and stars from light polluted areas or when the Moon is out.

Seeing

Seeing conditions refer to the stability of the atmosphere and directly effects the clarity of star images and the amount of fine detail seen in extended objects like the planets. The air in our atmosphere acts as a lens which bends and distorts incoming light rays. The amount of bending depends on air density. Varying temperature layers have different densities and therefore bend light differently. Light rays from the same object arrive slightly displaced creating an imperfect or smeared image. These atmospheric disturbances vary from time-to-time and place-to-place. The size of the air parcels compared to your aperture determines the "seeing" quality. Under good seeing conditions, fine detail is visible on the brighter planets like Jupiter and Mars, and stars are pinpoint images. Under poor seeing conditions, images are blurred and stars appear as blobs. Seeing conditions are rated on a five-point scale where one is the worst and five is the best (see figure 6-4). Seeing conditions can be classified in one of three categories which are based on the cause.

Type 1 seeing conditions are characterized by rapid changes in the image seen through the telescope. Extended objects, like the Moon, appear to shimmer while point sources (i.e., stars) appear double. Type 1 seeing is caused by currents within or very close to the telescope tube. These currents could be caused by a telescope that has not reached thermal equilibrium with the outdoor surroundings, heat waves from people standing near the telescope, or heated dew caps. To avoid the problems associated with Type 1 seeing, allow your telescope approximately 20 to 30 minutes to reach thermal

equilibrium. Once adjusted to the outdoor temperature, don't touch the telescope tube with your hands. When pointing the telescope, hold the C4.5 by the eyepiece holder. If observing with others, make sure no one stands in front of or directly below the telescope tube.

The images produced by Type 2 seeing conditions don't move as quickly as those produced by Type 1 conditions, but the images are quite blurry. Fine detail is lost and the contrast is low for extended objects. Stars are spread out and not sharp. The source of Type 2 seeing is the lower atmosphere, most likely heat waves from the ground or buildings. To avoid the problems associated with Type 2 seeing, select a good observing site. Specifically, avoid sites that overlook asphalt parking lots or plowed fields. Stay away from valleys and shorelines. Instead, look for broad hill tops or open grassy fields. Stable thermal conditions found near lakes and atmospheric inversions also tend to produce good seeing. If you can't get a better location, wait until the early morning hours when the surroundings are uniformly cool and the seeing is generally better.

Type 3 seeing conditions are characterized by fast ripples, but sharp images. In extended objects fine detail is visible, but the image shifts around the field. Stars are crisp points, but they shift small distances rapidly around the field. The cause of type 3 seeing is turbulence in the upper atmosphere which means the observer has less control over it. However, the effects of Type 3 seeing are generally less pronounced than the other two types. You can never really avoid Type 3 seeing. Your best bet is to wait until moments of steadiness. If the seeing is extremely bad, pack up and wait for a better night.

The conditions described here apply to both visual and photographic observations.



Figure 6-4

Seeing conditions directly affect image quality. These drawings represent a point source (i.e., star) under bad seeing conditions (left) to excellent conditions (right). Most often, seeing conditions produce images that lie somewhere between these two extremes.

CELESTIAL PHOTOGRAPHY

After looking at the night sky for awhile you may want to try photographing it. Several forms of celestial photography are possible with your Celestron C4.5 telescope. Two of the most common forms of celestial photography, in order of difficulty are short exposure prime focus and eyepiece projection, both of which can be done from urban areas. Each of these is discussed in moderate detail with enough information to get you started. Topics include the accessories required and some simple techniques. More information is available in some of the publications listed at the end of this manual.

In addition to the specific accessories required for each type of celestial photography, there is the need for a camera — but not just any camera. The camera does not need to have many of the features offered on today's state-of-the-art equipment. For example, you don't need auto focus capability or mirror lock up. Here are the mandatory features a camera needs for celestial photography. First, a 'B' setting which allows for time exposures. This excludes point and shoot cameras and limits the selection to SLR cameras, the most common type of 35mm camera on the market today.

Second, the 'B' or manual setting should not run off the battery. Many new electronic cameras use the battery to keep the shutter open during time exposures. Once the batteries are drained, usually after a few minutes, the shutter closes, whether you have finished with the exposure or not. Look for a camera that has a manual shutter when operating in the time exposure mode. Olympus, Nikon, Minolta, Pentax, Canon and others have made such camera bodies and some still do!

The camera must have interchangeable lenses so you can attach it to the telescope. If you can't find a new camera, you can purchase a used camera body that is not 100-percent functional. The light meter does not have to be operational since you will be determining the exposure length manually. The camera should, however, allow you to select the shutter speed.

Use a cable release with a locking function to hold the shutter open while you do other things. Mechanical and air releases are available.

Short Exposure Prime Focus

Short exposure prime focus photography is the best way to begin recording celestial objects. It is done with the camera attached to the telescope without an eyepiece or camera lens in place. To attach your camera, you need the Celestron T-Adapter (#93634-A) and a T-Ring for your specific camera (i.e., Minolta, Nikon, Pentax, etc.). The T-Ring replaces the 35mm SLR camera's normal lens. Prime focus photography allows you to capture the entire lunar disk or entire solar disk (if using the proper filter). To attach your camera to your C4.5:

1. Remove all visual accessories.
2. Thread the T-Ring onto the T-Adapter.
3. Mount your camera body onto the T-Ring the same as you would any other lens.
4. Thread the T-Adapter onto the focusing draw tube of the Celestron C4.5 while holding the camera in the desired orientation (either vertical or horizontal).

With your camera attached to the telescope, you are ready for prime focus photography. Start with an easy object like the Moon. Here's how to do it:

1. Load your camera with film that has a moderate-to-fast speed (i.e., ISO rating). Faster films are more desirable when the Moon is a crescent. When the Moon is near full, and at its brightest, slower films are more desirable. Here are some film recommendations:
 - T-Max 100
 - T-Max 400
 - Any 100 to 400 ISO color slide film
 - Fuji Super HG 400
2. Center the Moon in the field of your C4.5 telescope.
3. Focus the telescope by turning the focus knob until the image is sharp.
4. Set the shutter speed to the appropriate setting (see table 7-1).
5. Trip the shutter using a cable release.
6. Advance the film and repeat the process.

Lunar Phase	ISO 50	ISO 100	ISO 200	ISO 400
Crescent	1/2	1/4	1/8	1/15
Quarter	1/4	1/8	1/15	1/30
Full	1/60	1/125	1/250	1/500

Table 7-1

Above is a listing of recommended exposure times when photographing the Moon at the prime focus of your Celestron C4.5.

The exposure times listed here should be used as a starting point. Always make exposures that are longer and shorter than the recommended time. Also, try bracketing your exposures, taking a few photos at each shutter speed. This will ensure that you will get a good photo.

If using black and white film, try a yellow filter to reduce the light intensity and to increase contrast.

Keep accurate records of your exposures. This information is useful if you want to repeat your results or if you want to submit some of your photos to various astronomy magazines for possible publication!

This technique is also used for photographing the Sun with the proper Celestron solar filter.

Eyepiece Projection

This form of celestial photography is designed for objects with small angular sizes, primarily the planets and individual lunar features. Planets, although physically quite large, appear small in angular size because of their great distances. Moderate to high magnification is, therefore, required to make the image large enough to see any detail. Unfortunately, the camera/telescope combination alone does not provide enough magnification to produce a usable image size on film. In order to get the image large enough, you must attach your camera to the telescope with the eyepiece in place. To do so, you need two additional accessories; a tele-extender (#93647), which attaches onto the visual back, and a T-ring for your particular camera make (i.e., Minolta, Nikon, Pentax, etc.).

Because of the high magnifications during eyepiece projection, the field of view is quite small which makes it difficult to find and center objects. To make the job a little easier, align the finder as accurately as possible. This allows you to get the object in the field based on the finder's view alone.

Another problem introduced by the high magnification is vibration. Simply tripping the shutter — even with a cable release — produces enough vibration to smear the image. To get around this, use the camera's self-timer if the exposure time is less than one second — a common occurrence when photographing the Moon. For exposures over one second, use the "hat trick." This technique incorporates a hand-held black card placed over the aperture of the telescope to act as a shutter. The card prevents light from entering the telescope while the shutter is released. Once the shutter has been released and the vibration has diminished (a few seconds), move the black card out of the way to expose the film. After the exposure is complete, place the card over the front of the telescope and close the shutter. Advance the film and you're ready for your next shot. Keep in mind that the card should be held a few inches in front of the telescope, and not touching it. It is easier if you use two people for this process; one to release the camera shutter and one to hold the card. Here's the process for making the exposure.

1. Find and center the desired target in the view finder of your camera.
2. Turn the focus knob until the image is as sharp as possible.
3. Place the black card over the front of the telescope.
4. Release the shutter using a cable release.
5. Wait for the vibration caused by releasing the shutter to diminish. Also, wait for a moment of good seeing.
6. Remove the black card from in front of the telescope for the duration of the exposure (see table 7-2).
7. Replace the black card over the front of the telescope.
8. Close the camera's shutter.

Advance the film and you are ready for your next exposure. Don't forget to take photos of varying duration and keep accurate records of what you have done. Record the date, telescope, exposure duration, eyepiece, f /ratio, film, and some comments on the seeing conditions.

The following table lists exposures for eyepiece projection with a 12mm eyepiece. All exposure times are listed in seconds or fractions of a second.

Planet	ISO 50	ISO 100	ISO 200	ISO 400
Moon	2	1	1/2	1/4
Mercury	8	4	2	1
Venus	1/8	1/15	1/30	1/60
Mars	8	4	2	1
Jupiter	2	1	1/2	1/4
Saturn	8	4	2	1

Table 7-2

The exposure times listed here should be used as a starting point. Always make exposures that are longer and shorter than the recommended time. Also, try bracketing your exposures, taking a few photos at each shutter speed. This will ensure that you will get a good photo. It is not uncommon to go through an entire roll of 36 exposures and have only one shot turn out. Also, don't expect to record more detail than you can see visually in the eyepiece at the time you are photographing.

Once you have mastered the technique, experiment with different films, different focal length eyepieces, and even different filters.

TELESCOPE MAINTENANCE

After you have set up your telescope and started using it, there are a few things to remember for future reference.

Care and Cleaning of the Optics

To minimize the need to clean your telescope, replace all lens covers once you have finished using it. Since the front of the telescope tube is open **ALWAYS** replace the front cover when the telescope is not in use. This will minimize the amount of contaminants entering the optical tube and reduce the number of times your telescope needs to be cleaned.

The long tube of your C4.5 Newtonian telescope acts as a dew shield to prevent moisture from building up on the primary mirror. However, on extremely damp nights, the tube may only slow the formation of dew on the primary mirror. If dew condenses on the primary mirror it can be removed with a hair dryer or by pointing the telescope at the ground.

Occasionally, dust and/or moisture may build up on the primary mirror of your telescope. Special care should be taken when cleaning any optical instrument so as not to damage the optics. Internal adjustments and cleaning should be done only by the Celestron repair department. If your telescope is in need of internal cleaning, please call the Celestron repair department for specific information on service.

Collimation

The optical performance of your Celestron C4.5 telescope is directly related to the alignment of the optical system, more commonly referred to as collimation. Your C4.5 was collimated after it was completely assembled. However, if the telescope is dropped or jarred severely, it may have to be recollimated. There are two optical elements that may need to be adjusted. They are the primary and secondary mirrors.

To check the collimation of your telescope:

1. Point your telescope at a well-illuminated object like a wall or the daylight sky (away from the Sun).
2. Remove the accessory adapter and the long black tube that threads into the focuser.
3. Look into the opening in the focuser. You will see three things:
 - The reflection of your eye in the secondary mirror.
 - The reflection of the secondary mirror on the primary mirror and its support arms.
 - The reflection of the primary mirror in the secondary mirror. You will also see part of the inside of the tube.
4. Compare the view seen through the telescope with the illustration below. If the image seen through the telescope looks like this illustration then your telescope is out of collimation.

There are two types of adjustments that need to be made to correct this, which are the primary and secondary mirrors. Generally, you will adjust the primary mirror more often than the secondary mirror. These adjustments are described separately in the following sections.

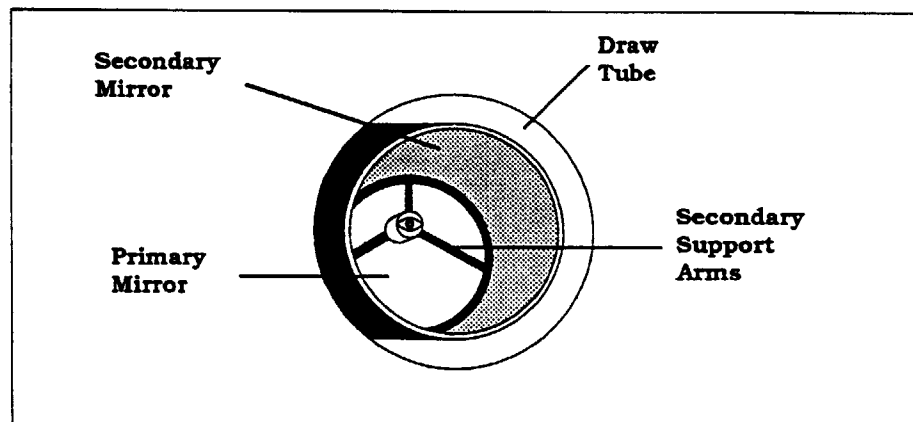

Figure 8-1

This illustration shows the image seen through a poorly collimated C4.5 Newtonian telescope. In this case, both the primary and secondary mirrors need adjusting.

Aligning the Secondary Mirror

To adjust the secondary mirror:

1. Locate the three positioning screws on the secondary mirror housing.
2. Loosen these three screws and rotate the secondary mirror so that it is facing the hole in the focuser (i.e., where the black draw tube and accessory adapter thread into).
3. Adjust the mirror so that the reflection of the primary mirror is centered in the image of the secondary mirror (see figure 8-2).
4. Tighten the screws to hold the secondary in place.

The secondary mirror is now properly aligned.

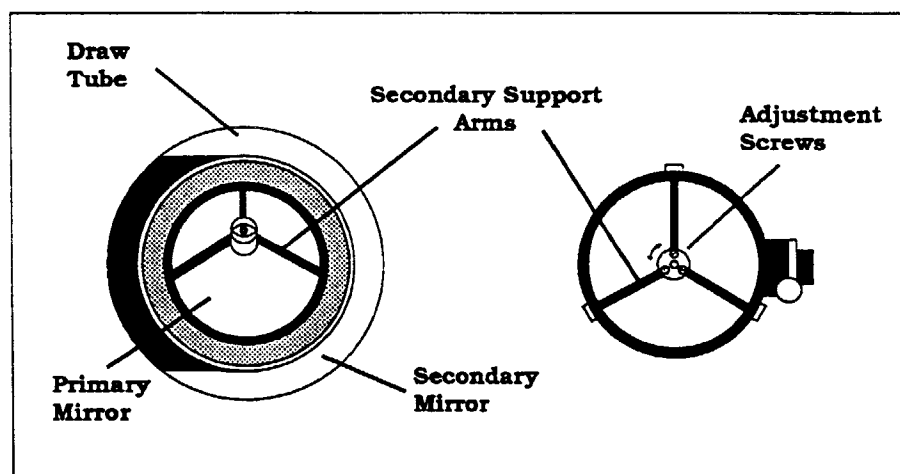

Figure 8-2

The illustration on the left shows the image seen through the telescope after the secondary adjustments have been made. The illustration on the right shows the adjustments screws on the back of the secondary mirror. This view is seen when looking down the telescope tube toward the primary mirror.

Aligning the Primary Mirror

To adjust the primary mirror:

1. Locate the adjustment screws at the end of the tube where the primary mirror sits.
2. Tighten and loosen the adjustment screws as needed to center the reflection of the secondary mirror in the primary mirror. This is a trial and error process!

The screws on the back of the primary mirror are paired. Within each pair one screw pushes on the primary mirror while the other one pulls. If you loosen a screw you must tighten its partner.

The primary mirror is now properly aligned. The telescope is in correct collimation and will produce the best possible images.

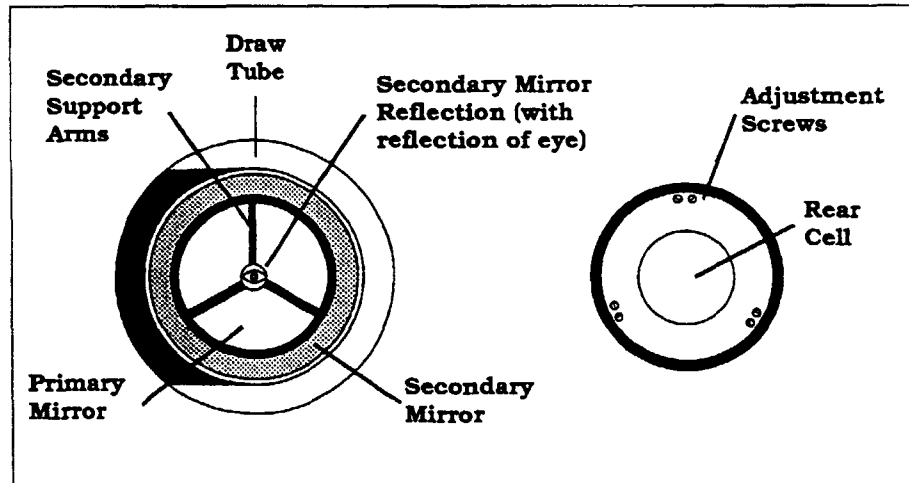

Figure 8-3

This illustration on the left shows the image seen through the telescope when properly collimated. As mentioned in the text, most collimation adjustments are made to the primary mirror. The illustration on the right shows the adjustment screws on the rear cell of the telescope.

OPTIONAL ACCESSORIES

The following is a list of optional accessories that can be used with your Celestron C4.5 Newtonian telescope. All the accessories are listed in alphabetical order. For a complete description of all accessories, ask for the Celestron Accessory Catalog (93685).

Accessory Case (#93500) - This rugged ABS plastic case is designed for carrying a few accessories. Inside is a foam padding that is die cut to 1x1 inch squares. These squares can be removed to accommodate the accessories and eyepieces with a custom fit.

Barlow Lenses - A Barlow lens is a negative lens that increases the focal length of a telescope. Used with any eyepiece, it doubles the magnification of that eyepiece. Celestron offers two Barlow lens in the 1-1/4" size for the C4.5 The 2x Ultima Barlow (#93506) is a compact triplet design that is multicoated for maximum light transmission and parfocal when used with the Ultima eyepieces. It works very well with all Celestron eyepieces. The latest Barlow to be added to Celestron's product line (#93507) is a low profile achromatic design. It weighs just 4 oz. and it under 3" in length.

Collimation Tool (#94183) - A valuable aid to assist you in collimating your Newtonian telescope. A simple tool and detailed instructions are included.

Eyepieces - Like telescopes, eyepieces come in a variety of designs. Each design has its own advantages and disadvantages. For the 1-1/4" barrel diameter there are four different eyepiece designs available.

- **SMA** - The SMA design is an improved version of the Kellner eyepiece. SMA's are very good, economical, general purpose eyepieces. Available in focal lengths of 6mm, 10mm, 12mm, and 25mm.
- **Plössl** - Plössl eyepieces have a 4-element lens designed for low-to-high power observing. The Plössls offer razor sharp views across the entire field, even at the edges! In the 1-1/4" barrel diameter, they are available in the following focal lengths: 6.3mm, 7.5mm, 10mm, 12.5mm, 17mm, 20mm, 26mm, 32mm and 40mm.
- **Ultima** - Ultima is not really a design, but a trade name for our 5-element, wide field eyepieces. In the 1-1/4" barrel diameter, they are available in the following focal lengths: 5mm, 7.5mm, 12.5mm, 18mm, 24mm, 30mm, 35mm, and 42mm. These eyepieces are all parfocal.
- **Lanthanum Eyepieces (LV Series)** - Lanthanum is a unique rare earth glass used in one of the field lenses of this new eyepiece. The Lanthanum glass reduces aberrations to a minimum. All are fully multicoated and have an astounding 20mm of eye relief — perfect for eyeglass wearers! In the 1-1/4" barrel diameter, they are available in the follow-

ing focal lengths: 2.5mm, 4mm, 5mm, 6mm, 9mm, 10mm, 12mm and 15mm. An 8-24mm zoom eyepiece is also available in the LV series.

In addition to the previously mentioned, there is also a deluxe compact zoom ocular (#93306) that has a variable focal length of 6.5 to 18mm. This provides 50 to 138 power on the C4.5.

Eyepiece Filters - To enhance your visual observations of planetary objects, Celestron offers a wide range of colored filters that thread into the 1-1/4" oculars. Available are: #12 Deep Yellow, #21 Orange, #25 Red, #58 Green, #80A Light Blue, #96 Neutral Density (25%, and 13% transmission) and Polarizing filters. The filters are sold separately (or some are available in sets) so you can buy them individually as you need them!

LED Flashlight (#93592) - The LED flashlight uses a red light emitting diode (LED) to allow reading star maps and locating telescope accessories and functions without ruining your night vision. The LED flashlight is small, only 6 inches long, and weighs in at a mere 3 ounces.

Light Pollution Reduction (LPR) Filters - These filters are designed to enhance your views of deep sky astronomical objects when viewed from urban areas. LPR Filters selectively reduce the transmission of certain wavelengths of light, specifically those produced by artificial lights. This includes mercury and high and low pressure sodium vapor lights. In addition, they also block unwanted natural light (sky glow) caused by neutral oxygen emission in our atmosphere. Celestron offers a model for 1-1/4" eyepieces (#94126A).

Micro Guide Eyepiece (#94171) - This multipurpose illuminated 12.5mm reticle can be used for guiding, measuring position angles, angular separations, and more. The laser etched reticle provides razor sharp lines and the variable brightness illuminator is completely cordless. The micro guide eyepiece produces 72 power when used with the C4.5.

Motor Drive with Drive Corrector - This unit is a motor drive and drive corrector in one. It is a necessity if you want to do any form of celestial photography. For the C4.5 we offer a single axis model which runs off DC power (#93516). The drive corrector function allows you to manually override the motors for corrections during celestial photography.

Polar Axis Finder Kit (#93605) - This accessory aids in the polar alignment process by improving the accuracy of your alignment and also reducing the alignment time. The kit includes a finder (15mm diameter objective lens, 3.5x magnification, 6° field of view) with eyepiece diopter adjustment, illuminated cross hair reticle, a 1.5 volt 'AA' battery, and instruction sheet.

Polarizing Filter Set (#93608) - The polarizing filter assembly limits the transmission of light to a specific plane, thus increasing contrast between various subjects. This is used primarily for terrestrial, lunar, and planetary observing.

Sky Maps (#93722) - When learning the night sky, the Celestron Sky Maps offer the ideal solution. The maps include all the constellations with the brighter deep-sky objects. The maps are printed on a heavy stock paper that is moisture-resistant. On the front cover is a rotating planisphere which indicates when specific constellations are visible.

Solar Filter (#94138) - Celestron Solar Screen® solar filters permit direct observation of the Sun with complete safety. These filters, which transmit .001% of visible light, allow you to see sunspots as they move with the Sun's rotation across the solar disk. In addition to reducing the intensity of the Sun's visible light, they also block 99.999% of invisible infrared light. The Celestron Solar Screen® solar filters are made of precision engineered aluminized Mylar® polyester film. A layer of aluminum is vacuum-deposited on one surface of the dual sheets of Mylar® used to make each filter. The aluminum coating produces a cool, comfortable pale blue image of the Sun. (A #21 orange eyepiece filter works well in conjunction with this filter to produce a more natural colored Sun with greater contrast.) This filter can be used for visual observation and photography.

T-Adapter (#93634-A) - A T-Adapter (with T-Ring) allows you to attach your camera to your C4.5 Newtonian for prime focus photography and is used for short exposure astrophotography. It can be used for long exposure work if you are using a separate guidescope.

T-C Adapter (#93636) - This adapter allows you to couple a video or movie camera to a telescope. The video camera must have a removable lens with a standard "C" thread. The T-C Adapter threads into the camera and then onto the T-Adapter.

T-Ring - The T-Ring couples your camera body to the T-Adapter, radial guider, and tele-extender. This accessory is mandatory if you want to do astrophotography through the telescope. Each camera make (i.e., Minolta, Nikon, etc.) has its own unique mount and therefore its own T-Ring.

Tele-Extender (#93647) - The tele-extender is a hollow tube that allows you to attach an eyepiece and a camera to the telescope. This accessory is used for eyepiece projection photography. The tele-extender threads into the focus tube and allows you to insert an eyepiece as well. When the eyepiece is not inserted, the tele-extender can be used as a T-Adapter.

Vibration Suppression Pads (#93503) - These pads rest between the ground and tripod feet of your telescope. They reduce the amplitude and vibration time of your telescope when shaken by the wind or bumped accidentally.

THE MESSIER CATALOG

The Messier Catalog, compiled by Charles Messier, was the first extensive listing of star clusters and nebulae. Messier's primary observational purpose was to discover comets. He compiled this list so that others searching for comets would not be confused by these objects. His list still remains popular today because all of these objects are easily visible in amateur telescopes.

M#	NGC#	Const.	R.A. H M S	DEC ° ' "	Mag	Type	Proper Name
M1	NGC 1952	Tau	5 34.5	22 01	8.4	P. Neb.	Crab Nebula
M2	NGC 7089	Aqr	21 33.5	-00 49	6.5	Gl. Cl.	
M3	NGC 5272	CVn	13 42.2	28 23	6.4	Gl. Cl.	
M4	NGC 6121	Sco	16 23.6	-26 32	5.9	Gl. Cl.	
M5	NGC 5904	Ser	15 18.5	2 05	5.8	Gl. Cl.	
M6	NGC 6405	Sco	17 40.0	-32 13	4.2	Op. Cl.	Butterfly Cluster
M7	NGC 6475	Sco	17 54.0	-34 49	3.3	Op. Cl.	
M8	NGC 6523	Sgr	18 03.7	-24 23	5.8	D. Neb.	Lagoon Nebula
M9	NGC 6333	Oph	17 19.2	-18 31	7.9	Gl. Cl.	
M10	NGC 6254	Oph	16 57.2	-4 06	6.6	Gl. Cl.	
M11	NGC 6705	Sct	18 51.1	-6 16	5.8	Op. Cl.	Wild Duck Cluster
M12	NGC 6218	Oph	16 47.2	-1 57	6.6	Gl. Cl.	
M13	NGC 6205	Her	16 41.7	36 28	5.9	Gl. Cl.	Hercules Cluster
M14	NGC 6402	Oph	17 37.6	-3 15	7.6	Gl. Cl.	
M15	NGC 7078	Peg	21 30.0	12 10	6.4	Gl. Cl.	
M16	NGC 6611	Ser	18 18.9	-13 47	6.0	D. Neb.	Eagle Nebula
M17	NGC 6618	Sgr	18 20.8	-16 11	7.0	D. Neb.	Omega Nebula
M18	NGC 6613	Sgr	18 19.9	-17 08	6.9	Op. Cl.	
M19	NGC 6273	Oph	17 02.6	-26 16	7.2	Gl. Cl.	
M20	NGC 6514	Sgr	18 02.4	-23 02	8.5	D. Neb.	Trifid Nebula
M21	NGC 6531	Sgr	18 04.7	-22 30	5.9	Op. Cl.	
M22	NGC 6656	Sgr	18 36.4	-23 54	5.1	Gl. Cl.	
M23	NGC 6494	Sgr	17 56.9	-19 01	5.5	Op. Cl.	
M24	NGC 6603	Sgr	18 16.4	-18 29	4.5	Op. Cl.	
M25	IC 4725	Sgr	18 31.7	-19 15	4.6	Op. Cl.	
M26	NGC 6694	Sct	18 45.2	-9 24	8.0	Op. Cl.	
M27	NGC 6853	Vul	19 59.6	22 43	8.1	P. Neb.	Dumbbell Nebula
M28	NGC 6626	Sgr	18 24.6	-24 52	6.9	Gl. Cl.	
M29	NGC 6913	Cyg	20 23.0	38 32	6.6	Op. Cl.	
M30	NGC 7099	Cap	21 40.4	-23 11	7.5	Gl. Cl.	
M31	NGC 224	And	0 42.7	41 16	3.4	Sp. Gx.	Andromeda Galaxy
M32	NGC 221	And	0 42.7	40 52	8.2	El. Gx.	
M33	NGC 598	Tri	1 33.8	30 39	5.7	Sp. Gx.	Pinwheel Galaxy
M34	NGC 1039	Per	2 42.0	42 47	5.2	Op. Cl.	
M35	NGC 2168	Gem	6 08.8	24 20	5.1	Op. Cl.	

M#	NGC#	Const.	R.A. H M S	DEC ° ' "	Mag	Type	Proper Name
M36	NGC 1960	Aur	5 36.3	34 08	6.0	Op. Cl.	
M37	NGC 2099	Aur	5 52.0	32 33	5.6	Op. Cl.	
M38	NGC 1912	Aur	5 28.7	35 50	6.4	Op. Cl.	
M39	NGC 7092	Cyg	21 32.3	48 26	4.6	Op. Cl.	
M40		UMa	12 22.2	58 05	8.0	dbl	
M41	NGC 2287	CMa	6 47.0	-20 44	4.5	Op. Cl.	
M42	NGC 1976	Ori	5 35.3	-5 27	4.0	D. Neb.	Great Orion Nebula
M43	NGC 1982	Ori	5 35.5	-5 16	9.0	D. Neb.	
M44	NGC 2632	Cnc	8 40.0	19 59	3.1	Op. Cl.	Beehive Cluster
M45		Tau	3 47.5	24 07	1.2	Op. Cl.	Pleiades
M46	NGC 2437	Pup	7 41.8	-14 49	6.1	Op. Cl.	
M47	NGC 2422	Pup	7 36.6	-14 30	4.4	Op. Cl.	
M48	NGC 2548	Hya	8 13.8	-5 48	5.8	Op. Cl.	
M49	NGC 4472	Vir	12 29.8	8 00	8.4	El. Gx.	
M50	NGC 2323	Mon	7 03.0	-8 20	5.9	Op. Cl.	
M51	NGC 5194-5	CVn	13 29.9	47 12	8.1	Sp. Gx.	Whirlpool Galaxy
M52	NGC 7654	Cas	23 24.2	61 35	6.9	Op. Gx.	
M53	NGC 5024	Com	13 12.9	18 10	7.7	Gl. Cl.	
M54	NGC 6715	Sgr	18 55.1	-30 29	7.7	Gl. Cl.	
M55	NGC 6809	Sgr	19 40.0	-30 58	7.0	Gl. Cl.	
M56	NGC 6779	Lyr	19 16.6	30 11	8.2	Gl. Cl.	
M57	NGC 6720	Lyr	18 53.6	33 02	9.0	P. Neb.	Ring Nebula
M58	NGC 4579	Vir	12 37.7	11 49	9.8	Sp. Gx.	
M59	NGC 4621	Vir	12 42.0	11 39	9.8	El. Gx.	
M60	NGC 4649	Vir	12 43.7	11 33	8.8	El. Gx.	
M61	NGC 4303	Vir	12 21.9	4 28	9.7	Sp. Gx.	
M62	NGC 6266	Oph	17 01.2	-30 07	6.6	Gl. Cl.	
M63	NGC 5055	CVn	13 15.8	42 02	8.6	Sp. Gx.	Sunflower Galaxy
M64	NGC 4826	Com	12 56.7	21 41	8.5	Sp. Gx.	Black Eye Galaxy
M65	NGC 3623	Leo	11 18.9	13 05	9.3	Sp. Gx.	Leo's Triplet
M66	NGC 3627	Leo	11 20.3	12 59	9.0	Sp. Gx.	Leo's Triplet
M67	NGC 2682	Cnc	8 50.3	11 49	6.9	Op. Cl.	
M68	NGC 4590	Hya	12 39.5	-26 45	8.2	Gl. Cl.	
M69	NGC 6637	Sgr	18 31.4	-32 21	7.7	Gl. Cl.	
M70	NGC 6681	Sgr	18 43.2	-32 18	8.1	Gl. Cl.	
M71	NGC 6838	Sge	19 53.7	18 47	8.3	Gl. Cl.	
M72	NGC 6981	Aqr	20 53.5	-12 32	9.4	Gl. Cl.	
M73	NGC 6994	Aqr	20 58.0	-12 38		ast	
M74	NGC 628	Psc	1 36.7	15 47	9.2	S	
M75	NGC 6864	Sgr	20 06.1	-21 55	8.6	Gl. Cl.	
M76	NGC 650-1	Per	1 42.2	51 34	11.5	P. Neb.	Cork Nebula
M77	NGC 1068	Cet	2 42.7	0 01	8.8	Sp. Gx.	
M78	NGC 2068	Ori	5 46.7	0 03	8.0	D. Neb.	
M79	NGC 1904	Lep	5 24.2	-24 33	8.0	Gl. Cl.	
M80	NGC 6093	Sco	16 17.0	-22 59	7.2	Gl. Cl.	

M#	NGC#	Const.	R.A. H M S	DEC ° ' "	Mag	Type	Proper Name
M81	NGC 3031	UMa	9 55.8	69 04	6.8	Sp. Gx.	Bodes Nebula
M82	NGC 3034	UMa	9 56.2	69 41	8.4	Ir. Gx.	
M83	NGC 5236	Hya	13 37.7	-29 52	7.6	Sp. Gx.	
M84	NGC 4374	Vir	12 25.1	12 53	9.3	El. Gx.	
M85	NGC 4382	Com	12 25.4	18 11	9.2	El. Gx.	
M86	NGC 4406	Vir	12 26.2	12 57	9.2	El. Gx.	
M87	NGC 4486	Vir	12 30.8	12 24	8.6	El. Gx.	Virgo A
M88	NGC 4501	Com	12 32.0	14 25	9.5	Sp. Gx.	
M89	NGC 4552	Vir	12 35.7	12 33	9.8	El. Gx.	
M90	NGC 4569	Vir	12 36.8	13 10	9.5	Sp. Gx.	
M91	NGC 4548	Com	12 35.4	14 30	10.2	Sp. Gx.	
M92	NGC 6341	Her	17 17.1	43 08	6.5	Gl. Cl.	
M93	NGC 2447	Pup	7 44.6	-23 52	6.2	Op. Cl.	
M94	NGC 4736	CVn	12 50.9	41 07	8.1	Sp. Gx.	
M95	NGC 3351	Leo	10 44.0	11 42	9.7	Sp. Gx.	
M96	NGC 3368	Leo	10 46.8	11 49	9.2	Sp. Gx.	
M97	NGC 3587	UMa	11 14.9	55 01	11.2	P. Neb.	Owl Nebula
M98	NGC 4192	Com	12 13.8	14 54	10.1	Sp. Gx.	
M99	NGC 4254	Com	12 18.8	14 25	9.8	Sp. Gx.	Pin Wheel Nebula
M100	NGC 4321	Com	12 22.9	15 49	9.4	Sp. Gx.	
M101	NGC 5457	UMa	14 03.2	54 21	7.7	Sp. Gx.	
M102	NGC 5457	UMa	14 03.2	54 21	7.7	dup	
M103	NGC 581	Cas	1 33.1	60 42	7.4	Op. Cl.	
M104	NGC 4594	Vir	12 40.0	-11 37	8.3	Sp. Gx.	Sombrero Galaxy
M105	NGC 3379	Leo	10 47.9	12 35	9.3	El. Gx..	
M106	NGC 4258	CVn	12 19.0	47 18	8.3	Sp. Gx.	
M107	NGC 6171	Oph	16 32.5	-13 03	8.1	Gl. Cl.	
M108	NGC 3556	UMa	11 11.6	55 40	10.0	Sp. Gx.	
M109	NGC 3992	UMa	11 57.7	53 23	9.8	Sp. Gx.	
M110	NGC 205	And	0 40.3	41 41	8.0	El. Gx.	

Object Abbreviations:

- Sp. Gx.Spiral Galaxy
- El. Gx.Elliptical Galaxy
- Ir. Gx.Irregular Galaxy
- Op. Cl.Open Cluster
- Gl. Cl.Globular Cluster
- D. Neb.Diffuse Nebula
- P. Neb.Planetary Nebula

NOTE: All coordinates for the objects in the Messier catalog are listed in epoch 2000.00.

LIST OF BRIGHT STARS

The following is a list of bright stars that can be used to align the R.A. setting circle. All coordinates are in epoch 2000.0.

Star Name	Constellation	Epoch 2000.0		Magnitude
		R.A. H M S	DEC ° ' "	
Sirius	CMa	06 45 09	-16 42 58	-1.47
Canopus	Car	06 23 57	-52 41 44	-0.72
Arcturus	Boo	14 15 40	+19 10 57	-0.72
Rigel Kent.	Cen	14 39 37	-60 50 02	+0.01
Vega	Lyr	18 36 56	+38 47 01	+0.04
Capella	Aur	05 16 41	+45 59 53	+0.05
Rigel	Ori	05 14 32	-08 12 06	+0.14
Procyon	CMi	07 38 18	+05 13 30	+0.37
Betelgeuse	Ori	05 55 10	+07 24 26	+0.41
Achernar	Eri	01 37 43	-57 14 12	+0.60
Hadar	Cen	14 03 49	-60 22 22	+0.63
Altair	Aqi	19 50 47	+08 52 06	+0.77
Aldebaran	Tau	04 35 55	+16 30 33	+0.86
Spica	Vir	13 25 12	-11 09 41	+0.91
Antares	Sco	16 29 24	-26 25 55	+0.92
Fomalhaut	Psa	22 57 39	-29 37 20	+1.15
Pollux	Gem	07 45 19	+28 01 34	+1.16
Deneb	Cyg	20 41 26	+45 16 49	+1.28
Beta Crucis	Cru	12 47 43	-59 41 19	+1.28
Regulus	Leo	10 08 22	+11 58 02	+1.36

FOR FURTHER READING

The following is a list of astronomy books that will further enhance your understanding of the night sky. The books are broken down by classification for easy reference.

Astronomy Texts

Astronomy Now	Pasachoff & Kutner
Cambridge Atlas of Astronomy	Audouze & Israel
McGraw-Hill Encyclopedia of Astronomy	Parker
Astronomy-The Evolving Universe	Zeilik

Atlases

Atlas of Deep Sky Splendors	Vehrenberg
Sky Atlas 2000.0	Tirion
Sky Catalog 2000.0 Vol 1 & 2	Hirshfeld & Sinnott
Uranometria Vol. 1 & 2	Tirion, Rappaport, Lovi
Magnitude 6 Star Atlas	Dickinson, Costanzo, Chaple
NGC 2000.0	Sinnott

General Observational Astronomy

The Cambridge Astronomy Guide	Liller & Mayer
A Complete Manual of Amateur Astronomy	Sherrod
The Guide to Amateur Astronomy	Newton & Teece

Visual Observation

Observational Astronomy for Amateurs	Sidgwick
Astronomical Calendar	Ottewell
Burnham's Celestial Handbook Vols. 1, 2 & 3	Burnham
The Planet Jupiter	Peek
Field Guide to The Stars & Planets	Menzel & Pasachoff
Observe Comets	Edberg & Levy

Astrophotography

Skys shooting	Mayall & Mayall
Astrophotography A Step-by-Step Approach	Little
Astrophotography for the Amateur	Covington
Astrophotography	Gordon
Astrophotography II	Martinez
A Manual of Celestial Photography	King
Manual of Advanced Celestial Photography	Wallis & Provin
Colours of The Stars	Malin & Muirden

CELESTRON ONE YEAR LIMITED WARRANTY

A. Celestron International (CI) warrants its telescopes to be free from defects in materials and workmanship for one year. CI will repair or replace such product or part thereof which, upon inspection by CI is found to be defective in materials or workmanship. As a condition to the obligation of CI to repair or replace such product, the product must be returned to CI together with proof-of-purchase satisfactory to CI.

B. The proper Return Authorization Number must be obtained from CI in advance of return. Call Celestron at 310-328-9560 to receive the number to be displayed on the outside of your shipping container.

All returns must be accompanied by a written statement setting forth the name, address and daytime telephone number of the owner, together with a brief description of any claimed defects. Parts or product for which replacement is made shall become the property of CI.

The customer shall be responsible for all costs of transportation and insurance, both to and from the factory of CI, and shall be required to prepay such costs.

CI shall use reasonable effort to repair or replace any telescope covered by this warranty within thirty days of receipt. In the event repair or replacement shall require more than thirty days, CI shall notify the customer accordingly. CI reserves the right to replace any product which has been discontinued from its product line with a new product of comparable value and function.

This warranty shall be void and of no force of effect in the event a covered product has been modified in design or function, or subjected to abuse, misuse, mishandling or unauthorized repair. Further, product malfunction or deterioration due to normal wear is not covered by this warranty.

CI disclaims any warranties, express or implied, whether of merchantability of fitness for a particular use, except as expressly set forth herein.

The sole obligation of CI under this limited warranty shall be to repair or replace the covered product, in accordance with the terms set forth herein. CI expressly disclaims any lost profits, general, special, indirect or consequential damages which may result from breach of any warranty, or arising out of the use or inability to use any CI product. Any warranties which are implied and which cannot be disclaimed shall be limited in duration to a term of one year from the date of original retail purchase.

Some states do not allow the exclusion or limitation of incidental or consequential damages or limitation on how long an implied warranty lasts, so the above limitations and exclusions may not apply to you. This warranty gives you specific legal rights, and you may also have other rights which vary from state to state.

CI reserves the right to modify or discontinue, without prior notice to you, any model or style of telescope. If warranty problems arise, or if you need assistance in using your telescope, contact:

Celestron International
Customer Service Department
2835 Columbia Street, Torrance, CA 90503
310-328-9560
310-212-5835 fax
Monday - Friday 8AM-4PM PST

This warranty supersedes all other product warranties.

NOTE: This warranty is valid to U.S.A. and Canadian customers who have purchased this product from an authorized CI dealer in the U.S.A. or Canada. Warranty outside the U.S.A. and Canada is valid only to customers who purchased from a CI International Distributor or Authorized CI Dealer in the specific country. Please contact them for any warranty service.

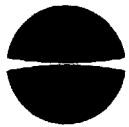

CELESTRON®

Celestron International
2835 Columbia Street
Torrance, CA 90503
Tel: 310-328-9560
Fax: 310-212-5835

Copyright 1997 Celestron International
All right reserved
(Products or instructions may change
without notice or obligation).

Item# 94109
6-97
Price \$10.00

Free Manuals Download Website

<http://myh66.com>

<http://usermanuals.us>

<http://www.somanuals.com>

<http://www.4manuals.cc>

<http://www.manual-lib.com>

<http://www.404manual.com>

<http://www.luxmanual.com>

<http://aubethermostatmanual.com>

Golf course search by state

<http://golfingnear.com>

Email search by domain

<http://emailbydomain.com>

Auto manuals search

<http://auto.somanuals.com>

TV manuals search

<http://tv.somanuals.com>