



CELESTRON



**The CR-150 HD
6" Refractor**

Model #21017

INSTRUCTION MANUAL

TABLE OF CONTENTS

▲ INTRODUCTION	4
How to Use this Manual	5
A Word of Caution	5
The Refractor Optical System	6
▲ ASSEMBLING YOUR CR-150 HD	7
The CR-150 HD	8
Assembling the CG-5 Equatorial Mount	9
Setting Up the Tripod	9
Adjusting the Tripod Height	9
Attaching the Accessory Tray	10
Attaching the Equatorial Mount	11
Attaching the R.A. Slow Motion Knob	12
Attaching the Declination Slow Motion Knob	13
Attaching the Counterweight Bar and Counterweights	14
Attaching the Telescope to the Mount	15
Removing the Lens Cap	16
Balancing the Telescope in R.A.	17
Balancing the Telescope in DEC	17
Adjusting the Mount in Altitude	18
Adjusting the Mount in Azimuth	18
Disassembling and Transporting Your CR-150 HD	19
Storing Your CR-150 HD	19
Technical Specification	19
▲ TELESCOPE BASICS	20
Attaching the Accessories	20
The Star Diagonal	20
The Eyepiece	20
Focusing	22
Attaching the Finder	22
Aligning the Finder	23
Image Orientation	24
Your First Look	24
Daytime Observing	24
Nighttime Observing	25
Calculating Magnification	26
Determining Field of View	26
General Photography Hints	27
▲ ASTRONOMY BASICS	28
The Celestial Coordinate System	28
Motion of the Stars	29
Polar Alignment	30
Finding the Pole	31
Latitude Scales	32
Pointing at Polaris	33
Declination Drift	34
Polar Alignment Finders	35
Aligning the R.A. Setting Circle	35

▲	CELESTIAL OBSERVING	36
	Observing the Moon	36
	Observing the Planets	37
	Using the Lens Cap Aperture Stop.....	37
	Observing the Sun	37
	Observing Deep-Sky Objects	38
	Using the Setting Circles	38
	Star Hopping	39
	Viewing Conditions	41
	Transparency	41
	Sky Illumination	41
	Seeing	41
▲	CELESTIAL PHOTOGRAPHY	43
	Short Exposure Prime Focus	44
	Piggyback	46
	Projection Photography	48
▲	TELESCOPE MAINTENANCE.....	49
	Care and Cleaning of the Optics	49
▲	OPTIONAL ACCESSORIES	50
▲	THE MESSIER CATALOG.....	53
▲	LIST OF BRIGHT STARS	56
▲	FOR FURTHER READING	57

I N T R O D U C T I O N

Welcome to the Celestron world of amateur astronomy! For more than a quarter of a century, Celestron has provided amateur astronomers with the tools to explore the universe. The line of Celestron refractors continues in this proud tradition. Each telescope is made of the highest quality materials to ensure durability and stability. And, your Celestron refractor is versatile — it will grow as your interest grows. All this adds up to a telescope that will give you a lifetime of pleasure with a minimal amount of maintenance. All you need to do is take the time to familiarize yourself with your Celestron telescope and its operation.

How to Use This Manual



This manual is designed to instruct you in the proper use of your Celestron refracting telescope. This includes assembly, initial use, and long term operation and maintenance. There are four major sections to the manual. The first section covers the proper procedure for setting up your Celestron refracting telescope.

The second section covers basic operations that are common to all telescopes. This includes attaching the accessories, focusing, aligning the finderscope, and taking your first look.

The third section deals with the basics of astronomy and using your telescope for astronomical viewing. This includes polar alignment, aligning the setting circles and using your Celestron for astronomical observations, both visual and photographic. The last major section is on telescope maintenance, specifically on care and cleaning.

In addition to the major sections listed above, there is a list of optional accessories for all models of Celestron refractors. This includes a brief description of the accessory and its purpose.

Finally, there is a list of celestial objects visible through your Celestron telescope. Included are the coordinates for each object, its brightness and a code which indicates object type. In addition, there is a list of bright stars that can be used for aligning the setting circles on the CG-5 equatorial mount.

You should keep your refractor manual handy until you have fully mastered your telescope's operation.

A Word of Caution!

Your Celestron refractor is designed to give you hours of fun and rewarding observations. However, there are a few things to consider before using your telescope that will ensure your safety and protect your eyes and your equipment.

WARNING !

NEVER LOOK DIRECTLY AT THE SUN WITH THE NAKED EYE OR WITH A TELESCOPE. PERMANENT AND IRREVERSIBLE EYE DAMAGE MAY RESULT.

NEVER USE YOUR TELESCOPE TO PROJECT AN IMAGE OF THE SUN ONTO ANY SURFACE. INTERNAL HEAT BUILD-UP CAN DAMAGE THE TELESCOPE AND/OR ANY ACCESSORIES ATTACHED TO IT.

NEVER USE AN EYEPIECE SOLAR FILTER OR A HERSHEY WEDGE. INTERNAL HEAT BUILD-UP INSIDE THE TELESCOPE CAN CAUSE THESE DEVICES TO CRACK OR BREAK, ALLOWING UNFILTERED SUNLIGHT TO PASS THROUGH TO THE EYE.

NEVER LEAVE THE TELESCOPE UNSUPERVISED, EITHER WHEN CHILDREN ARE PRESENT OR ADULTS WHO MAY NOT BE FAMILIAR WITH THE CORRECT OPERATING PROCEDURES OF YOUR TELESCOPE.

NEVER POINT YOUR TELESCOPE AT THE SUN UNLESS YOU HAVE THE PROPER SOLAR FILTER. WHEN USING YOUR TELESCOPE WITH THE CORRECT SOLAR FILTER, ALWAYS COVER THE FINDER. ALTHOUGH SMALL IN APERTURE, THIS INSTRUMENT HAS ENOUGH LIGHT GATHERING POWER TO CAUSE PERMANENT AND IRREVERSIBLE EYE DAMAGE. IN ADDITION, THE IMAGE PROJECTED BY THE FINDER IS HOT ENOUGH TO BURN SKIN OR CLOTHING.

The Refractor Optical System

Developed in the early 1600s, the refractor is the oldest telescope design. It derives its name from the method it uses to focus incoming light rays. The refractor uses a lens to bend or refract incoming light rays, hence the name (see Figure 1-1). Early designs used single element lenses. However, the single lens acts like a prism and breaks light down into the colors of the rainbow, a phenomenon known as chromatic aberration. To get around this problem, a two-element lens, known as an achromat, was introduced. Each element has a different index of refraction allowing two different wavelengths of light to be focused at the same point. Most two-element lenses, usually made of crown and flint glasses, are corrected for red and green light. Blue light may still be focused at a slightly different point.

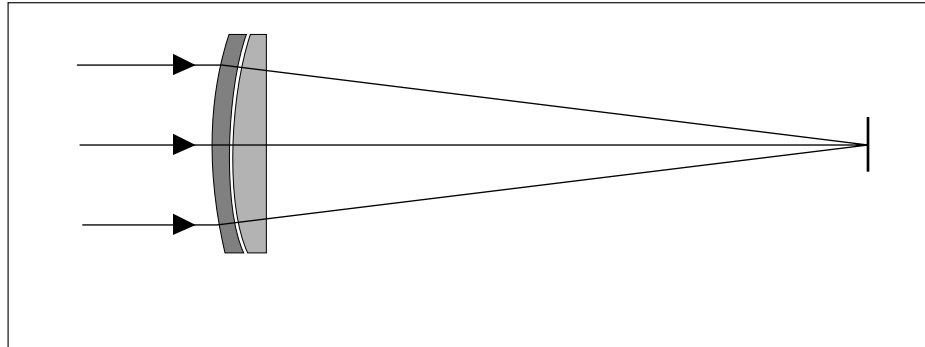

Figure 1-1

This cross sectional diagram shows the light path of a classical two-element refractor.

The Mount

In the world of astronomy, there are basically two different types of mounts; Altazimuth and equatorial. Both derive their names from the axial motion of the mount. The Altazimuth moves vertically (altitude) and horizontally (azimuth) relative to the horizon. The equatorial mount has its axis of rotation tilted so that it can be aligned with the Earth's axis of rotation. When this is done, the telescope (when fitted with an optional clock drive) can track the stars. The directional movements on this mount are North/South and East/West. The Celestron CR-150 HD, 6 inch refractor uses a German equatorial mount called the CG-5 mount.

ASSEMBLING YOUR CR - 150 HD

The CR-150 HD (#21017) refracting telescope is offered on a German equatorial mount. The CR-150 HD is shipped in two boxes. The first box includes the optical tube and all of the standard accessories, which include:

- 20mm Plossl Ocular 1-1/4"
- Star Diagonal 1-1/4"
- 2x Barlow Lens 1-1/4", with built-in Camera Adapter
- 9x50mm Finder and Bracket
- Lens Cap with 112mm aperture stop

The second box contains the tripod, equatorial mount and the hardware needed to set it up. Included are the:

- CG-5 German Equatorial Mount
- Counterweight Bar
- Two 5.1Kg (11 lb.) Counterweights
- Declination (DEC) Slow Motion Knob
- Right Ascension (R.A.) Slow Motion Knob
- Adjustable Aluminium Tripod
- Accessory Tray

Unpacking Your CR-150 HD

When setting up the telescope, find a large, clear area where the parts can be laid out without fear of losing them. Start with the tripod and mount. Remove the contents of the box and place them neatly on your work surface. Leave the optical tube in its box until you are ready to attach it to the mount. Once your CR-150 HD has been unpacked and assembled, you will not need the shipping boxes for everyday storage and transportation. However, you should save them in case you decide to ship your telescope via a common carrier.

The CR-150 HD

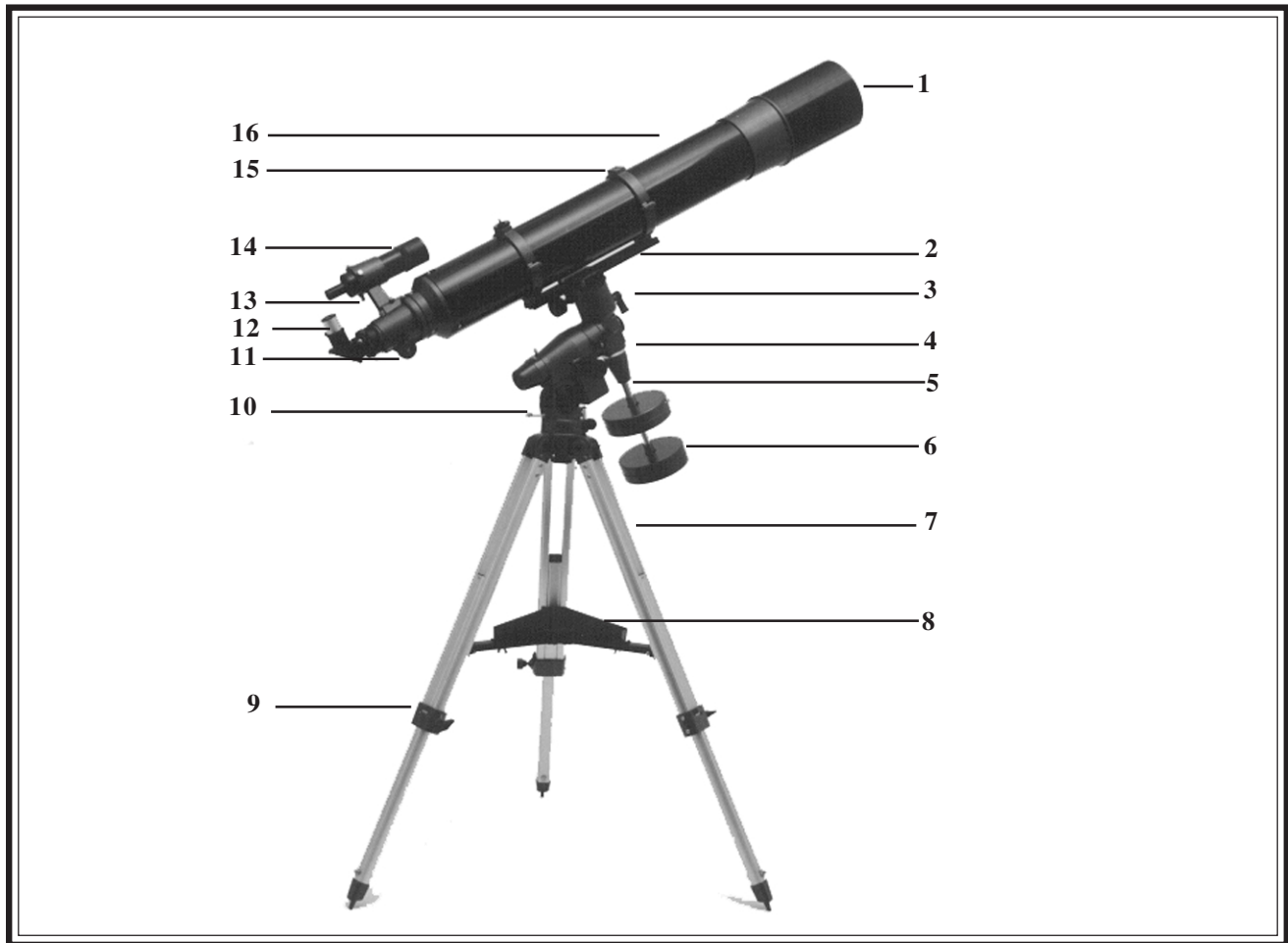

Figure 2-1

- | | |
|--------------------------------------|--------------------------------------|
| 1. Lens Cap (not shown) | 9. Leg Extension Clamp |
| 2. Dovetail Slidebar | 10. Latitude Adjustment Screw |
| 3. Declination Lock | 11. Focus Knobs |
| 4. Declination Setting Circle | 12. Eyepiece |
| 5. Counterweight Shaft | 13. Finderscope Bracket |
| 6. Counterweights | 14. Finderscope |
| 7. Tripod Leg | 15. Tube Mounting Rings |
| 8. Accessory Tray | 16. Optical Tube |

Assembling the CG-5 Equatorial Mount

Setting Up the Tripod

The tripod comes fully assembled with the metal plate, called the tripod head, that holds the legs together at the top. In addition, the brackets that support the accessory tray are also attached to the tripod.

Stand the tripod upright and pull the tripod legs apart until the leg brace assembly for the accessory tray is fully extended (see figure 2-2). The tripod will now stand by itself. To increase the stability, tighten the bolts that hold the legs to the tripod head (use the appropriate size wrench from the supplied set). This will help minimize any flexure or wobble of the legs.

Adjusting the Tripod Height

Once the tripod is set up, you can adjust the height at which it stands. To do this:

1. Loosen the knob on the leg clamp so that the tripod leg can be adjusted.
2. Slide the center portion of the tripod leg away from the tripod head until it is at the desired height.
3. Tighten the knobs on each leg clamp to hold the legs in place.

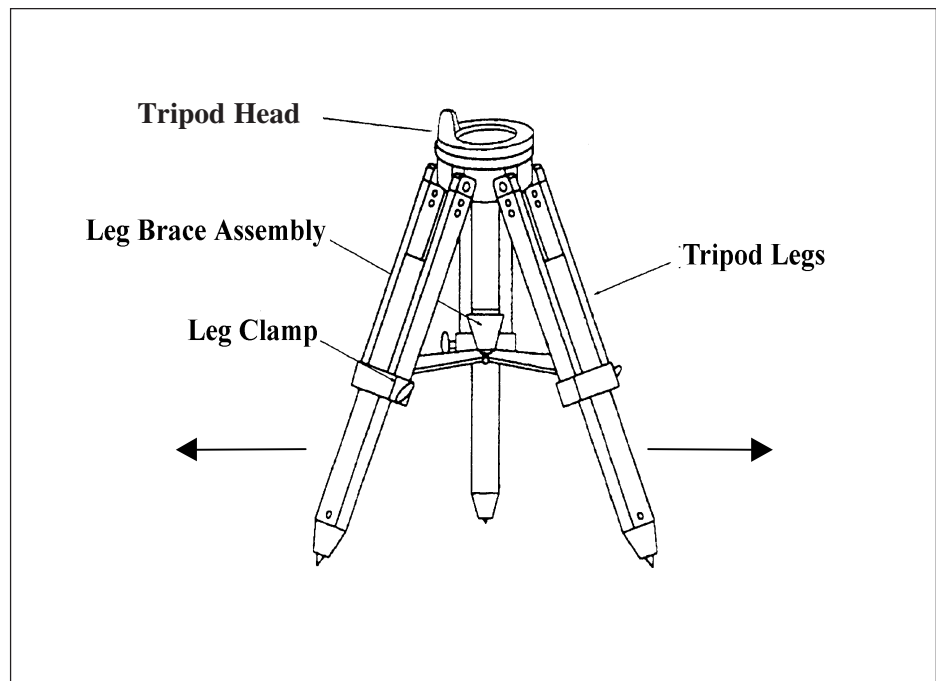

Figure 2-2

Setting up the tripod requires nothing more than pulling the tripod legs away from the tripod head. The height at which the tripod stands can be adjusted by sliding the slats in the center of each leg toward or away from the tripod head.

Attaching the Accessory Tray

With the tripod set up, you are ready to attach the accessory tray to the tripod. There are three wing bolts that hold the accessory tray to the bracket.

1. Locate the three wing bolts.
2. Place the accessory tray over the bracket and position it so the thread holes in the accessory tray are above the slotted holes in the bracket.
3. Insert the wing bolts up through the slotted holes in the bracket (see figure 2-3).
4. Thread the wing bolts into the holes in the accessory tray.
5. Tighten the wing bolts fully.

With the accessory tray in place, the tripod will be much more stable making it easier to attach the mount and telescope.

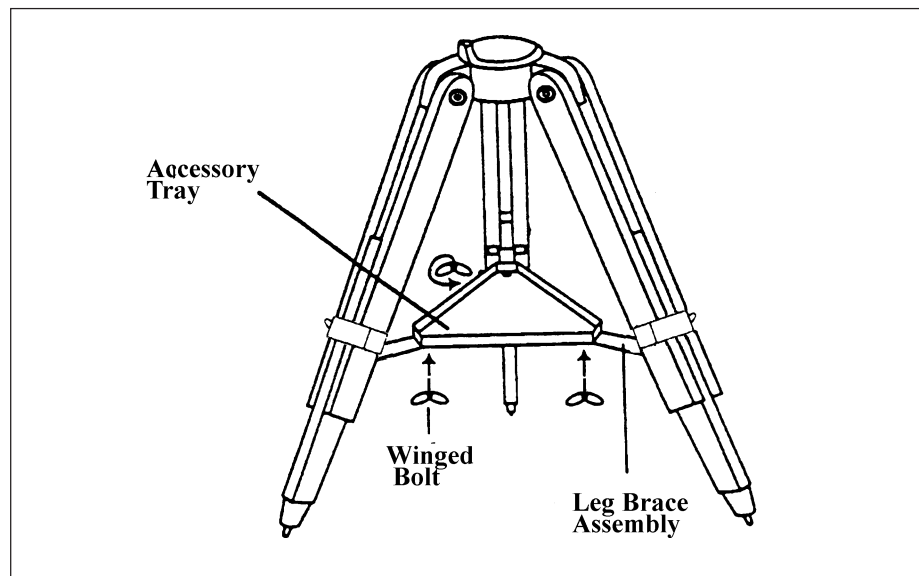

Figure 2-3

Attaching the Equatorial Mount

The equatorial mount allows you to tilt the telescope's axis of rotation so that you can track the stars as they move across the sky. The CG-5 mount is a German equatorial mount that attaches to the tripod head (i.e., metal plate on the tripod). On one side of the plate there is an "N" which signifies north. This side of the tripod will face north when setting up for an astronomical observing session. Above the "N" is a peg about 3/4" high that points straight up. To attach the equatorial head:

1. Locate the azimuth adjustment screws on the equatorial mount.
2. Retract the screws so they no longer extend into the azimuth housing (rectangular extrusion) on the mount. **Do NOT remove the screws since they are needed later for polar alignment.**
3. Hold the equatorial mount over the tripod head so that the azimuth housing is above the metal peg.
4. Place the equatorial mount on the tripod head so that the two are flush.
5. Tighten the knob on the underside of the tripod head to hold the equatorial mount firmly in place. The knob is already attached and can **NOT** be removed.

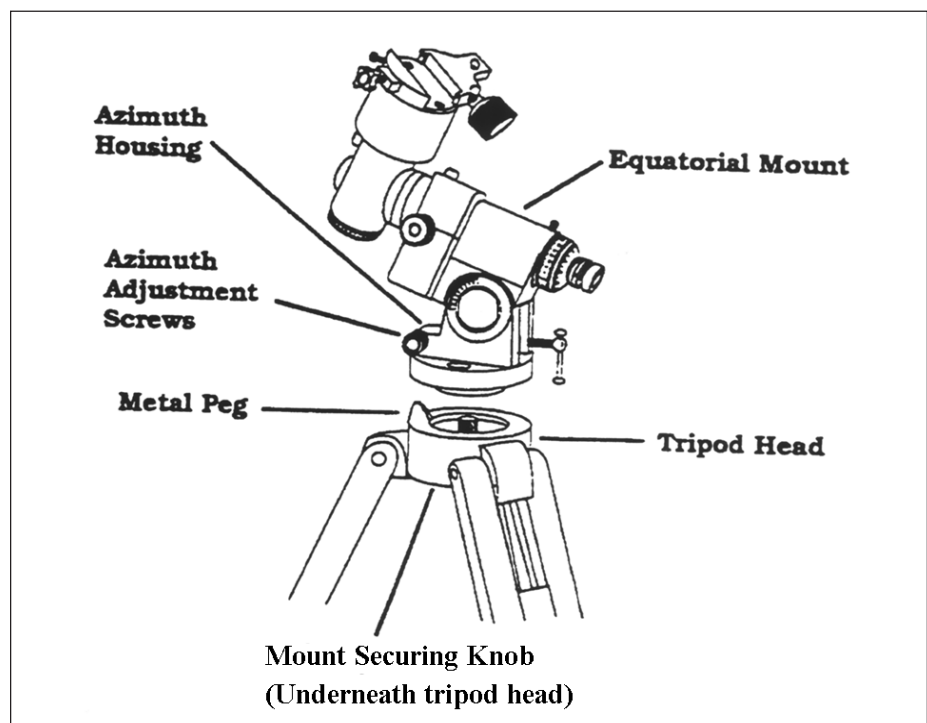

Figure 2-4

Attaching the R.A. Slow Motion Knob

With the mount securely in place, you are ready to attach some of the accessories (the telescope tube will be added last). Start with the Right Ascension (R.A.) slow motion knob. The R.A. slow motion knob allows you to make fine pointing adjustments in the direction the telescope is aiming (once it is attached to the mount). To install the knob:

1. Locate the hard plastic shell under the R.A. shafts.
2. Remove either of the two oval tabs by pulling tightly.
3. Line up the flat area on the inner portion of the R.A. slow motion knob with the flat area on the R.A. shaft.
4. Slide the R.A. slow motion knob onto the R.A. shaft.

The knob is a tension fit, so sliding it on holds it in place. As mentioned above, there are two R.A. shafts, one on either side of the mount. It makes no difference which shaft you use since both work the same. Use whichever one you find more convenient. If, after a few observing sessions, you find the R.A. slow motion knob is more accessible from the other side, pull firmly to remove the knob, then install it on the opposite side.

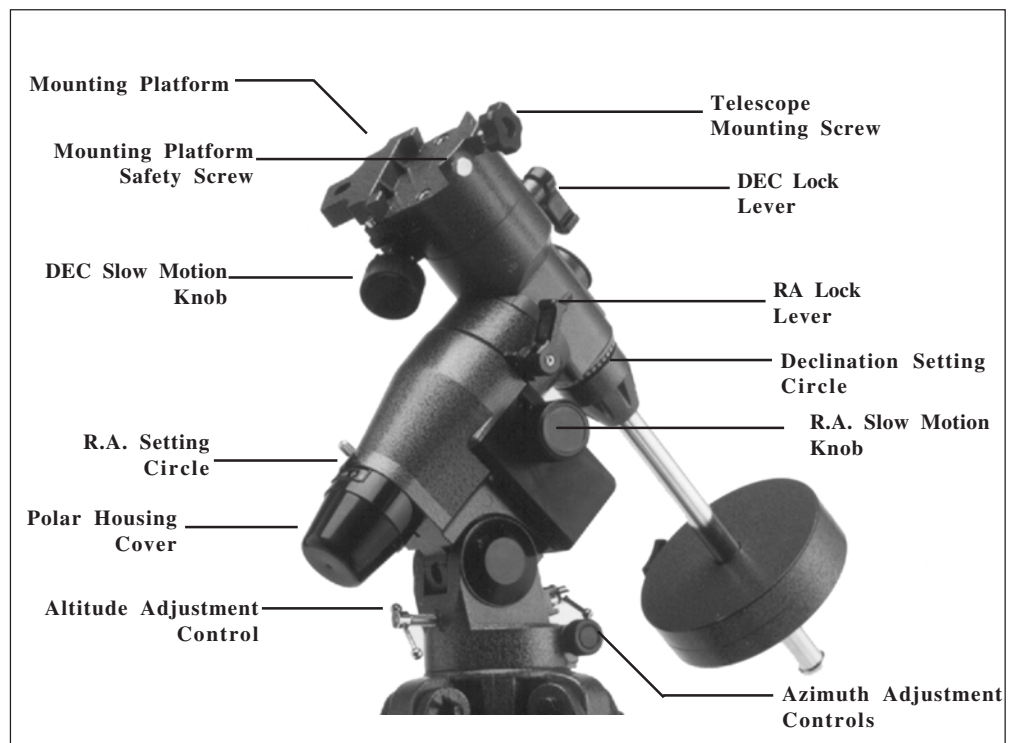

Figure 2-5

Attaching the Declination Slow Motion Knob

Like the R.A. slow motion knob, the DEC slow motion knob allows you to make fine pointing adjustments in the direction the telescope is pointed.

The DEC slow motion knob attaches in the same manner as the R.A. knob. The shaft that the DEC slow motion knob fits over is toward the top of the mount, just below the telescope mounting platform. Once again, you have two shafts to choose from. Use the shaft that is pointing toward the ground. This makes it easy to reach while looking through the telescope, something which is quite important when you are observing.

1. Line up the flat area on the inner portion of the DEC slow motion knob with the flat area on the DEC shaft.
2. Slide the DEC slow motion knob over the DEC shaft (see figure 2-6).

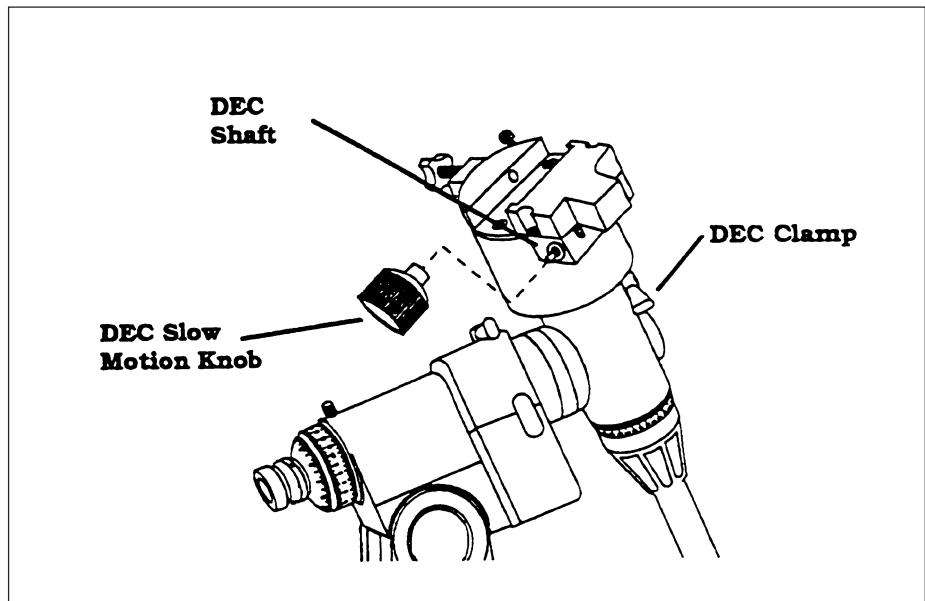

Figure 2-6

Attaching the Counterweight Bar and Counterweights

The last item to be mounted before the telescope tube is the counterweight bar and counterweights. Used to balanced the telescope, the counterweight bar attaches to the opposite side of the mount as the telescope. To install the counterweight bar:

1. Retract the counterweight bar lock nut by turning it counterclockwise. This will expose the threads on the end of the counterweight bar.
2. Thread the counterweight bar into the mount completely. Once again, **it threads into the mount opposite the telescope tube** (see figure 2-7).
3. Tighten the counterweight bar lock nut fully for added support.

The counterweight bar is now installed. With the counterweight bar in place, you are ready to attach the counterweights.

1. Lock the DEC clamp to hold the mount in place.
2. Remove the safety thumbscrew on the end of the counterweight bar.
3. Loosen the set screw on the counterweight itself so that the central hole of the counterweight is unobstructed.
4. Slide the counterweight onto the counterweight bar. Move it high enough to allow room for the second weight (see figure 2-7).
5. Tighten the set screw on the counterweight to hold it in position.
6. Repeat this process for the second weight.
7. Replace the safety thumbscrew on the end of the counterweight bar. The thumbscrew will prevent the counterweights from sliding off the bar should they ever become loose.

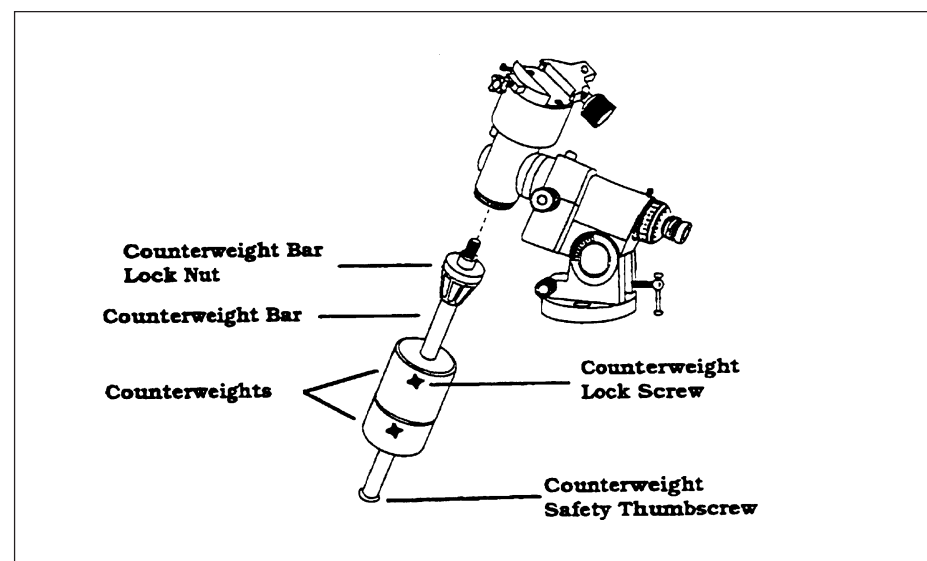

Figure 2-7

Attaching the Telescope to the Mount

With the mount fully assembled, you are ready to attach the telescope to the mount.

The optical tube attaches to the mount using a dovetail slidebar that is fastened to two tube rings that clamp around the tube.

- **Before you attach the optical tube, fully tighten the right ascension and declination clamps. This will prevent the telescope from moving suddenly once attached to the mount.**
1. Loosen the hand knob on the side of the CG-5 mount.
 2. Slide the dovetail bar that is attached to the telescope's tube rings onto the mounting platform of the CG-5 mount (see figure 2-8).
 3. Tighten the knob on the CG-5 mount to hold the telescope in place.

NOTE:

Never loosen any of the knobs on the telescope tube or mount. Also, be sure that the objective lens end of the telescope is pointing away from the ground at all times.

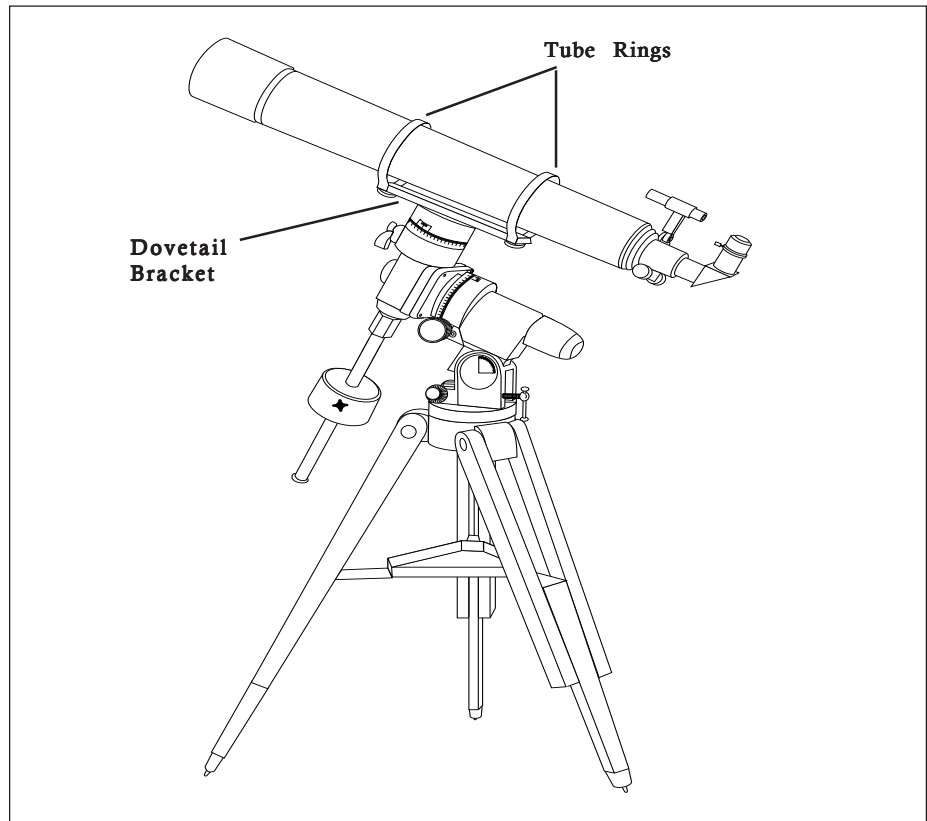

Figure 2-8

This illustration shows the optical tube mounted on the CG-5 mount. The dovetail slide bar has been attached to the telescope tube and is ready to attach to the CG-5 mount.

Balancing the Telescope in R.A.

To eliminate undue stress on the mount, the telescope should be properly balanced around the polar axis. In addition, proper balancing is crucial for accurate tracking if using an optional motor drive. To balance the mount:

1. Release the R.A. Clamp and position the telescope off to one side of the mount (make sure that the balance bracket thumbscrew is tight). The counterweight bar will extend horizontally on the opposite side of the mount (see figure 2-9).
2. Release the telescope — **GRADUALLY** — to see which way the telescope “rolls.”
3. Loosen the set screw on one or both counterweights.
4. Move the counterweights to a point where they balance the telescope (i.e., it remains stationary when the R.A. clamp is released).
5. Tighten the set screw to hold the counterweight(s) in place.

These are general balance instructions and will reduce undue stress on the mount. When taking astrophotos, this balance process should be done for the specific area at which the telescope is pointing.

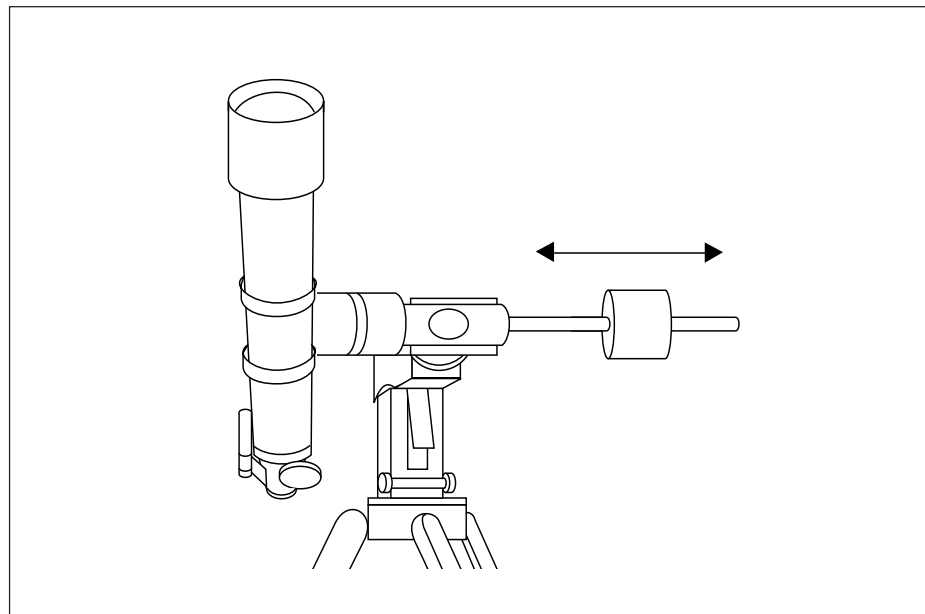

Figure 2-9

The telescope should be balanced after all the standard accessories (i.e., star diagonal, eyepiece, etc.) have been attached to the telescope. The correct procedure for attaching these accessories is discussed in the section on “Telescope Basics.”

Balancing the Telescope in DEC

The telescope should also be balanced on the declination axis to prevent any sudden motions when the DEC clamp is released. To balance the telescope in DEC:

1. Release the R.A. clamp and rotate the telescope so that it is on one side of the mount (i.e., as described in the previous section on balancing the telescope in R.A.).
2. Lock the R.A. clamp to hold the telescope in place.
3. Release the DEC clamp and rotate the telescope until the tube is parallel to the ground (see figure 2-10).
4. Release the tube — **GRADUALLY** — to see which way it rotates around the declination axis. **DO NOT LET GO OF THE TELESCOPE TUBE COMPLETELY!**
5. Slightly loosen the balance bracket thumbscrew and slide the telescope either forward or backward until it remains stationary when the DEC clamp is released. **Do NOT let go of the telescope tube while the balance bracket thumbscrew is loose.**
6. Tighten the thumbscrew firmly to hold the telescope in place.

Like the R.A. balance, these are general balance instructions and will reduce undue stress on the mount. When taking astrophotographs, this balance process should be done for the specific area at which the telescope is pointing.

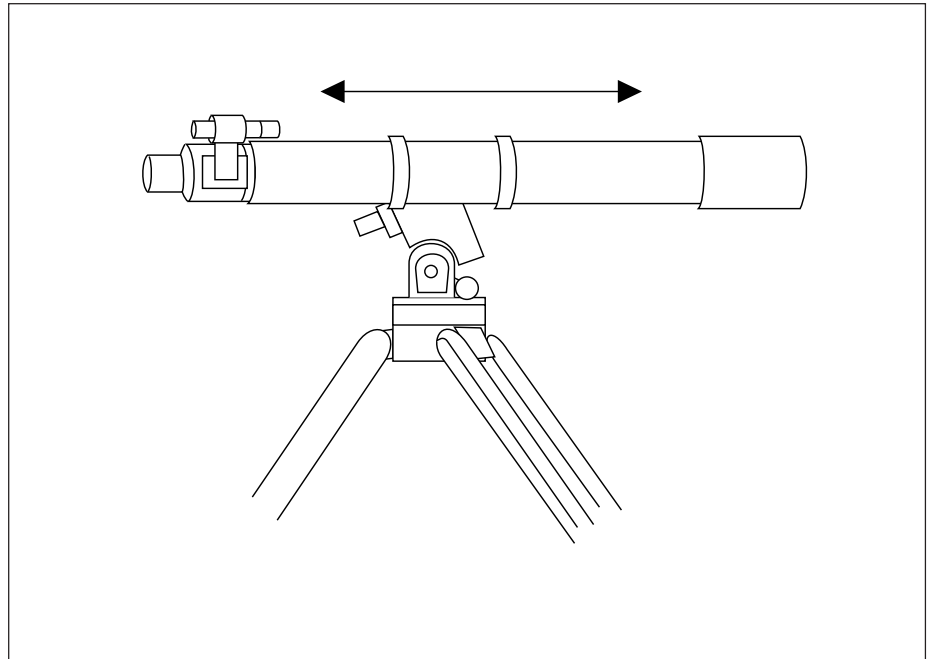

Figure 2-10

As with R.A., the telescope should be balanced in DEC after all the standard accessories (i.e., star diagonal, eyepiece, etc.) have been attached to the telescope.

Adjusting the Mount in Altitude

For the purpose of polar alignment, there are two directions in which the mount can be adjusted; vertically, which is called altitude and horizontally, which is called azimuth. There are several ways to align on the celestial pole, some of which are discussed later in this manual. This section simply covers the correct movement of the mount during the polar alignment process. To adjust the mount in altitude (i.e., raise or lower the angle of the polar axis), turn the altitude adjustment lever:

- Turning the lever clockwise increases the angle at which the polar axis is pointing
- Turning the lever counterclockwise lowers the angle at which the polar axis is pointing.

The latitude adjustment on the CG-5 mount has a range of 40°, starting at 20° going up to 60°.

Adjusting the Mount in Azimuth

For rough adjustments in azimuth, simply pick up the telescope and tripod and move it. For fine adjustments in azimuth:

1. Turn the azimuth adjustment screws located on either side of the azimuth housing. While standing behind the telescope, the knobs are on the front of the mount.
 - Turning the right adjustment knob clockwise moves the mount toward the right.
 - Turning the left adjustment knob clockwise moves the mount to the left.

Both screws push off of the peg on the tripod head, which means you may have to loosen one screw while tightening the other. The screw that holds the equatorial mount to the tripod may have to be loosened slightly.

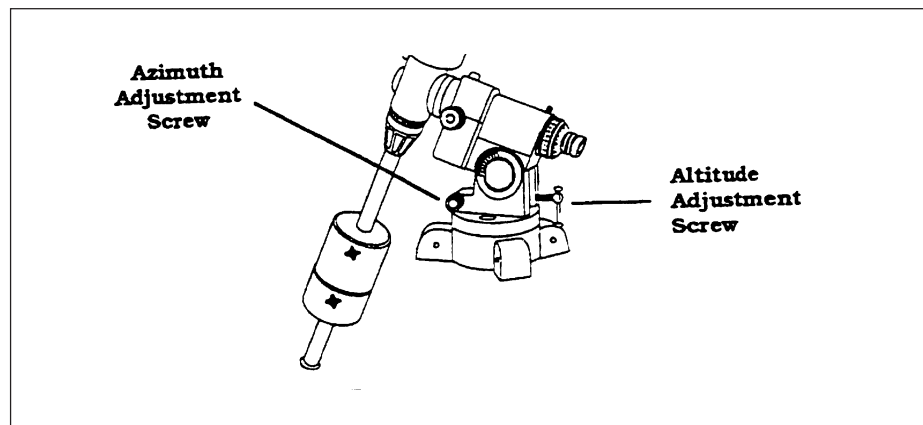

Figure 2-11

Disassembling and Transporting Your CR-150 HD

The entire telescope and mount is light enough to pick up and carry outside for a casual observing session. If, however, you want to transport your CR-150 HD to a remote observing location, you must partially disassemble it. Here's how:

1. Remove the telescope from the equatorial mount. Return it to the shipping carton to ensure safe transportation.
2. Remove the three wing bolts that hold the accessory tray to the tripod.
3. Pull the accessory tray off the bracket.
4. Thread the wing bolts back onto the accessory tray once they are removed from the bracket. This will eliminate the possibility of losing them.
5. Fold the tripod legs together and you are ready to transport your CR-150 HD telescope.

The equatorial mount does **NOT** have to be removed if you are transporting the telescope yourself. However, you may want to remove the counterweights from the counterweight bar to lighten the mount.

If you are shipping the telescope via a common carrier, you should completely disassemble the telescope and return all parts to their original shipping container.

Storing Your CR-150 HD

When not in use, your Celestron CR-150 HD can be left fully assembled and set up. However, all lens and eyepiece covers should be put back in place. The opening to the rear cell must also be covered. This will reduce the amount of dust build-up on the optical surfaces and reduce the number of times you need to clean the instrument. You may want to return everything to its original shipping container and store all the parts there. If this is the case, all optical surfaces should still be covered to prevent dust build-up.

Technical Specifications

Below is pertinent technical information on your Celestron CR-150 HD refractor telescope that you may find useful.

OPTICAL TUBE:	CR-150 HD
Optical System:	Refractor
Aperture:	6" (150mm)
Focal Length:	1200mm (48")
F/ratio:	f/8
Highest Useful Power Magnification:	360x
Lowest Useful Power Magnification:	21x
Resolution (arc seconds):	0.33
Photographic Resolution:	182 lines/mm
Light Gathering Power:	459x
Limiting Visual Magnitude:	13.4
Optical Tube Length:	50.5"
Weight	
Optical Tube:	18.5 lbs.

Once your telescope has been fully assembled, you are ready to attach the accessories and have a look. This section deals with basic telescope operations that are common to all Celestron refractor telescopes.

Attaching the Accessories

There are several accessories that come standard with all the Celestron refractor telescopes. The installation and use of each of these is described in this section.

The Star Diagonal

The star diagonal uses a mirror that reflects the light at a right angle to the light path of the telescope. This allows you to observe in positions that are physically more comfortable than if you were to look straight through. To attach the star diagonal:

1. Turn the set screw on the accessory adapter until it no longer extends into (i.e., obstructs) its inner diameter of the visual back.
2. Slide the chrome portion of the star diagonal into the accessory adapter (see figure 4-1).
3. Tighten the set screw to hold the star diagonal in place.

If you wish to change the orientation of the star diagonal, loosen the set screw on the visual back until the star diagonal rotates freely. Rotate the diagonal to the desired position and tighten the set screw.

The Eyepiece

The eyepiece, or ocular, is an optical element that magnifies the image focused by the telescope. The eyepiece(s) fits into either the accessory adapter directly, the star diagonal, or an erect image diagonal (see *Optional Accessories* section). To attach an eyepiece:

1. Loosen the set screw on the star diagonal so that it does not obstruct the inner diameter of the eyepiece end of the diagonal.
2. Slide the chrome portion of the eyepiece into the star diagonal (see figure 4-1).
3. Tighten the set screw to hold the eyepiece in place.

To remove the eyepiece, loosen the set screw on the star diagonal and slide the eyepiece out. You can then replace it with another ocular.

Eyepieces are commonly referred to by focal length and barrel diameter. The focal length of each eyepiece is printed on the eyepiece barrel. The longer the focal length (i.e., the larger the number) the lower the eyepiece magnification (i.e., power) and the shorter the focal length (i.e., the smaller the number) the higher the magnification. Generally, you will use low-to-moderate power when viewing. For more information on how to determine power, see the section on "Calculating Magnification."

Barrel diameter is the diameter of the barrel that slides into the star diagonal or accessory adapter. Your CR-150 HD refracting telescope can use eyepieces with both a 1-1/4" barrel diameter and 2" barrel diameter. To use a 2" barrel eyepiece, the 1 1/4" accessory adapter must first be removed. To do this, simply loosen the two chrome thumbscrews located around the focuser barrel (see figure 4-1) and remove the 1 1/4" adapter. Once removed, a 2" eyepiece or accessory can be inserted directly into the focuser barrel and secured with the two thumb screws.

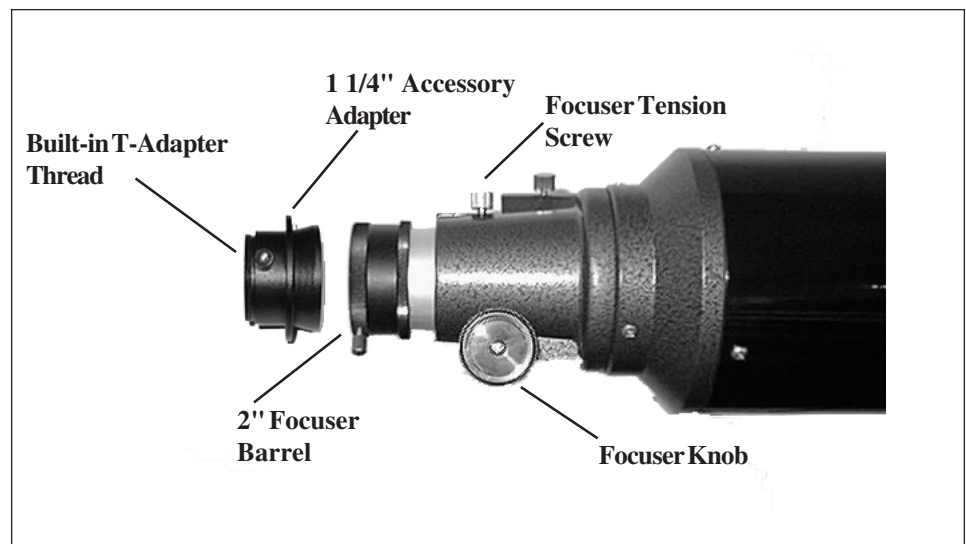

Figure 4-1

Focusing

To focus your telescope, simply turn either of the focus knobs located under the focus tube (see figure 4-1). Turn the focus knobs until the image is sharp. Once sharp, turn the knobs toward you to focus on an object that is closer than the one you are currently observing. Turn the knobs away from you to focus on a more distant object than the one you are currently observing.

When working with any optical instrument, there are a few things to remember to ensure you get the best possible image.

- Never look through window glass. Glass found in household windows is optically imperfect, and as a result, may vary in thickness from one part of a window to the next. This inconsistency can and will affect the ability to focus your telescope. In most cases you will not be able to achieve a truly sharp image, while in some cases, you may actually see a double image.
- Never look across or over objects that are producing heat waves. This includes asphalt parking lots on hot summer days or building rooftops.
- Hazy skies, fog, and mist can also make it difficult to focus when viewing terrestrially. The amount of detail seen under these conditions is greatly reduced. Also, when photographing under these conditions, the processed film may come out a little grainier than normal with lower contrast and underexposed.
- If you wear corrective lenses (specifically glasses), you may want to remove them when observing with an eyepiece attached to the telescope. When using a camera, however, you should always wear corrective lenses to ensure the sharpest possible focus. If you have astigmatism, corrective lenses must be worn at all times.

Attaching the Finder

The finder is mounted in the bracket and only needs to be attached to the telescope. On the back of the telescope tube, just above the focusing knobs, there is a small bracket with a regular head screw in it. This is where the finder bracket is mounted. To install the finderscope:

1. Locate the mounting bracket near the back of the telescope tube.
2. Loosen the regular head screw from the mounting bracket on the telescope.
3. Slide the finder bracket onto the bracket on the telescope. The finder bracket will slide in from the back. Orient the finder so that the objective lens is toward the objective end of the telescope.
4. Tighten the regular head screw on the bracket to hold the finder in place.

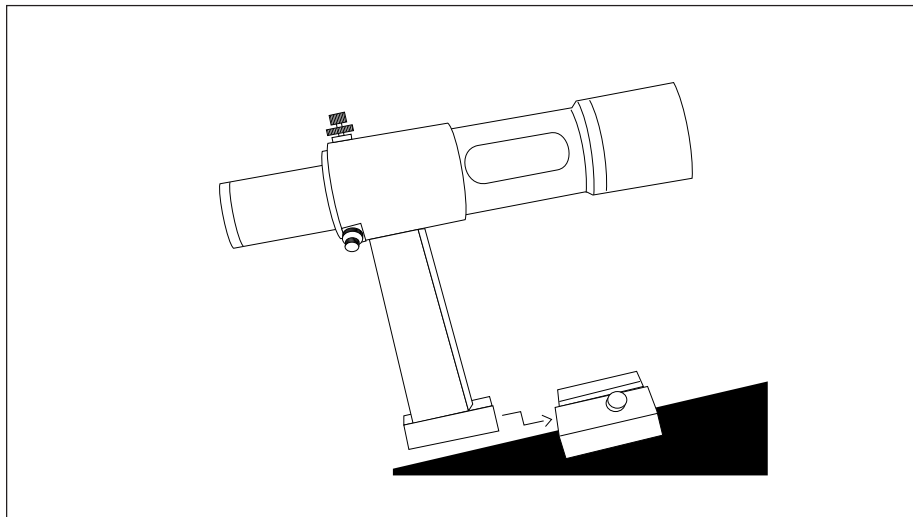

Figure 4-2

The finder comes mounted in the finder bracket. To mount the finder to the telescope, the finder bracket attaches to the mounting bracket on the telescope.

Aligning the Finder

The CR-150 HD comes with a 9x50mm finder. The finder is designed to help you find objects that are easily overlooked in the main optics of the telescope. The first number used to describe the finder is the power. The second number is the diameter of the objective lens in millimeters. For example, the CR-150 HD finder is 9x50 which means it is 9 power and has a 50mm objective lens. Incidentally, power is always compared to the unaided human eye. So, a 9 power finder magnifies images nine times more than the human eye.

The 9x50mm finder is adjusted using two adjustment screws, located on the top and on the right (when looking through the finder) of the finder bracket and a spring loaded pivot screw (located on the left side of the bracket). This allows you to turn the top adjustment screw to move the finderscope up and down, and turn the right adjustment screw to move the finderscope right to left. The spring loaded pivot screw puts constant pressure on the finder so that the adjustment screws are always making contact with the finder.

To make things a little easier, you should align the finder during the day when it is easier to locate objects. To align the finder:

1. Choose a conspicuous object that is over 500 yards away. This will eliminate any possible parallax effect.
2. Point your telescope at the target and center it in the main optics of the telescope (the eyepiece).
3. Lock the R.A. and DEC clamps to hold the telescope in place.
4. Check the finder to see where the object is located in the field of view.
5. Adjust the screws on the finder bracket, tightening one while loosening another, until the cross hairs are centered on the target.

Accurate alignment of the finder will make it much easier to find objects in the main optical tube.

Image Orientation

It should be noted that the image orientation will change depending on the viewing configuration. When using the star diagonal, the image is right-side-up, but reversed from left-to-right. If inserting the eyepiece into the accessory adapter (i.e., without the star diagonal), the image is inverted (upside down and reversed from left-to-right). This holds true for the 9x50 finder as well as the telescope. For correct orientation through the telescope, which is important primarily for terrestrial observing, use the optional 45° erect image diagonal 1-1/4" (#94112-A).



Actual image orientation as seen with the unaided eye



Reversed from left to right, as viewed with a Star Diagonal



Inverted image, as viewed with the eyepiece directly in telescope

Figure 4-3

Your First Look

With the telescope fully assembled and all the accessories attached you are ready for your first look. Your first look should be done in the daytime when it will be easier to locate the locking clamps and adjustment handles. This will help to familiarize you with your telescope, thus making it easier to use at night.

Daytime Observing

Your Celestron CR-150 HD telescope works well as a terrestrial spotting scope. When not used to examine objects in the night sky, it can be used to study objects here on Earth.

WARNING !

NEVER POINT YOUR TELESCOPE AT THE SUN UNLESS YOU HAVE THE PROPER SOLAR FILTER. PERMANENT AND IRREVERSIBLE EYE DAMAGE MAY RESULT AS WELL AS DAMAGE TO YOUR TELESCOPE. ALSO, NEVER LEAVE YOUR TELESCOPE UNATTENDED DURING A DAYTIME OBSERVING SESSION, ESPECIALLY WHEN CHILDREN ARE PRESENT.

1. Begin by finding a distant object that is fairly bright.
2. Insert the eyepiece (one with a large focal length) into the telescope.
3. Release the R.A. and DEC clamps and point the telescope at the object you selected.
4. Locate the object in your finder and lock the R.A. and DEC clamps.
5. Use the slow motion knobs to center the object in the field of the finder.
6. Once centered, look through the main optics and the object will be there (if you aligned the finder first).

Nighttime Observing

Looking at objects in the sky is quite different than looking at objects on Earth. For one, many objects seen in the daytime are easy to see with the naked eye and can be located by using landmarks. In addition, objects on the ground are stationary, at least for the most part. In the night sky you will see a tremendous amount of stars through the telescope that are not visible to the naked eye. One way to find objects (at least initially) is by using other stars to guide you there. This method of finding objects, known as star hopping, is very accurate. Yet it requires a fair amount of time to learn the stars well enough to guide you to other objects. In addition, the stars will appear to drift out of the field of view. This is due to the Earth's rotation. In fact, anything in the sky, day or night, will drift out unless the telescope has been polar-aligned and an optional motor drive is running. There is more on this in the section on "Polar Alignment."

1. Orient the telescope so that the equatorial mount is pointing north, as close to true north as possible. You can use a landmark that you know faces north to get you in the general direction.
2. Adjust the mount until the latitude indicator points to the latitude of your observing site.
3. Insert the eyepiece (low power) into the telescope to give you the widest field possible.
4. You are now ready to observe.
5. Release the right ascension and declination clamps and point the telescope at the desired target. The Moon or one of the brighter planets is an ideal first target.
6. Locate the object in the finder.
7. Lock the R.A. and DEC clamps to hold the telescope in place.
8. Center the object in the finder using the slow motion knobs.
9. Turn the focus knob until the image is sharp.
10. Take your time and study your subject. If looking at the Moon, look for small details in the craters.

That's all there is to using your Celestron telescope. However, don't limit your view of an object to a single eyepiece. After a few minutes, try using a different optional eyepiece, a more powerful one. This gives you an idea of how the field of view changes.

Calculating Magnification

You can change the power of your Celestron CR-150 HD telescope just by changing the eyepiece (ocular). To determine the magnification for your telescope, you would simply divide the focal length of the telescope (1200mm) by the focal length of the eyepiece that you are using. In equation format, the formula looks like this:

$$\text{Magnification} = \frac{\text{Focal Length of Telescope (mm)}}{\text{Focal Length of Eyepiece (mm)}}$$

Let's say, for example, that you are using a 20mm eyepiece. To determine the magnification, simply divide the focal length of your telescope (1200mm) by the focal length of the eyepiece (20mm). Dividing 1200 by 20 yields a magnification of 60 power.

Although the power is variable, each instrument has a limit to the highest useful magnification. The general rule is that 60 power can be used for every inch of aperture. For example, the CR-150 HD is 6" in diameter. Multiplying 6 by 60 gives a maximum useful magnification of 360 power. Although this is the maximum useful magnification, due to limiting atmospheric conditions most observing is done in the range of 20 to 35 power for every inch of aperture which is 120 to 210 power for the CR-150 HD.

Determining Field of View

Determining the field of view is important if you want to get an idea of the size of the object you are observing. To calculate the actual field of view, divide the apparent field of the eyepiece (supplied by the eyepiece manufacturer) by the magnification. In equation format, the formula looks like this:

$$\text{True Field} = \frac{\text{Apparent Field of Eyepiece}}{\text{Magnification}}$$

Using the example we started with above, we can determine the field of view using the same 20mm eyepiece. The 20mm eyepiece has an apparent field of view of 52°. Divide the 52° by the magnification, which is 60 power. This yields an actual field of .87°, or a little more than three quarters of a degree.

For terrestrial viewing, field size is often referred to as feet at a thousand yards. To convert this to feet at one thousand yards, multiply the actual field of .87° by 52.5. This produces a field width of 45.7 feet at one thousand yards.

The apparent field of each eyepiece that Celestron manufacturers is found in the Celestron Accessory Catalog (#93685).

General Photography Hints

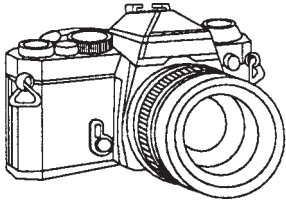

Your Celestron telescope can be used for both terrestrial and astronomical photography. Your telescope has a fixed aperture and, as a result, a fixed f /ratio. To properly expose your subjects photographically, you need to set your shutter speed accordingly. Most 35mm single lens reflex (SLR) cameras offer through-the-lens metering that lets you know if your picture is under or overexposed. This is important for terrestrial photography where exposure times are measured in fractions of a second. In astrophotography, the exposures are much longer, requiring that you use the “B” setting on your camera. The actual exposure time is determined by how long you keep the shutter open. More on this in the section on “Celestial Photography.”

To reduce vibration when tripping the shutter, use a cable release. Releasing the shutter manually can cause vibration, something that produces blurred photos. A cable release allows you to keep your hands clear of the camera and telescope, thus reducing the possibility of shaking the telescope. Mechanical shutter releases can be used, though air-type releases are best.

ASTRONOMY BASICS

This section deals with observational astronomy in general. It includes information on the night sky, polar alignment, and using your telescope for astronomical observations.

The Celestial Coordinate System

In order to help find objects in the sky, astronomers use a celestial coordinate system which is similar to our geographical coordinate system here on Earth. The celestial coordinate system has poles, lines of longitude and latitude, and an equator. For the most part, these remain fixed against the background stars.

The celestial equator runs 360 degrees around the Earth and separates the northern celestial hemisphere from the southern. Like the Earth's equator it bears a reading of zero degrees. On Earth this would be latitude. However, in the sky this is now referred to as declination, or DEC for short. Lines of declination above and below the celestial equator are labeled for their angular distance from the equator. The lines are broken down into degrees, minutes, and seconds of arc. Declination readings south of the equator carry a minus sign (-) in front of the number and those north are often preceded by a plus sign (+).

The celestial equivalent of longitude is called Right Ascension, or R.A. for short. Like the Earth's lines of longitude, they run from pole to pole and are evenly spaced 15 degrees apart. Although the longitude lines are separated by an angular distance, they are also a measure of time. Each line of longitude is one hour apart from the next. Since the Earth rotates once every 24 hours, there are 24 lines total. The R.A. coordinates are marked off in units of time. It begins with an arbitrary point in the constellation of Pisces designated as 0 hours, 0 minutes, 0 seconds. All other points are designated by how far (i.e., how long) they lag behind this coordinate after it passes overhead moving toward the west.

Your Celestron telescope comes equipped with setting circles that translate the celestial coordinates into a precise location for the telescope to point. The setting circles will not work properly until you have polar aligned the telescope and set the R.A. setting circle. Note that the process of polar alignment sets the declination setting circle.

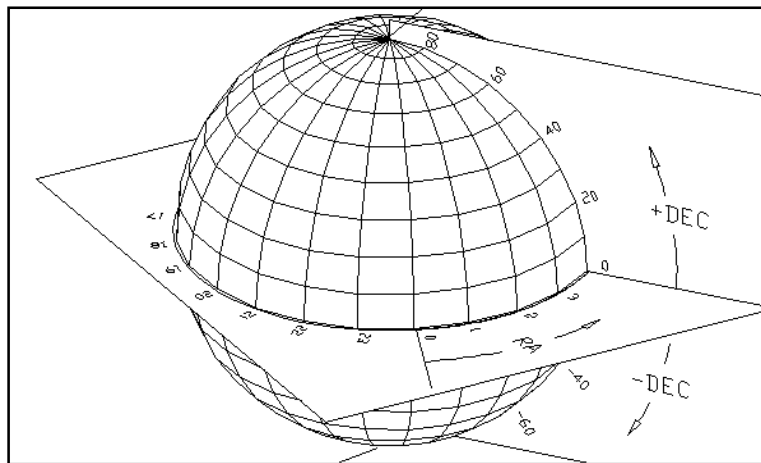

Figure 5-1

Motion of the Stars

Like the Sun, the stars also appear to move across the sky. This motion is caused by the Earth's rotation. For observers in the northern hemisphere, all stars appear to move around the north celestial pole. For observers in the southern hemisphere, all stars appear to move around the south celestial pole. This means that over a 24-hour period, any given star will scribe out a complete circle around its respective celestial pole. The farther you move away from the celestial pole, the larger this circle becomes and is largest at the celestial equator. Stars near the celestial equator rise in the east and set in the west. However, stars near the celestial poles are always above the horizon. They are said to be circumpolar because they don't rise and set. You will never see the stars complete one circle because the sunlight during the day washes out the starlight. However, part of this circular motion of stars in this region of the sky can be seen by setting up a camera on a tripod and opening the shutter for a couple of hours. The processed film will reveal circular arcs that are centered on the pole. This information will be useful for certain methods of polar alignment.

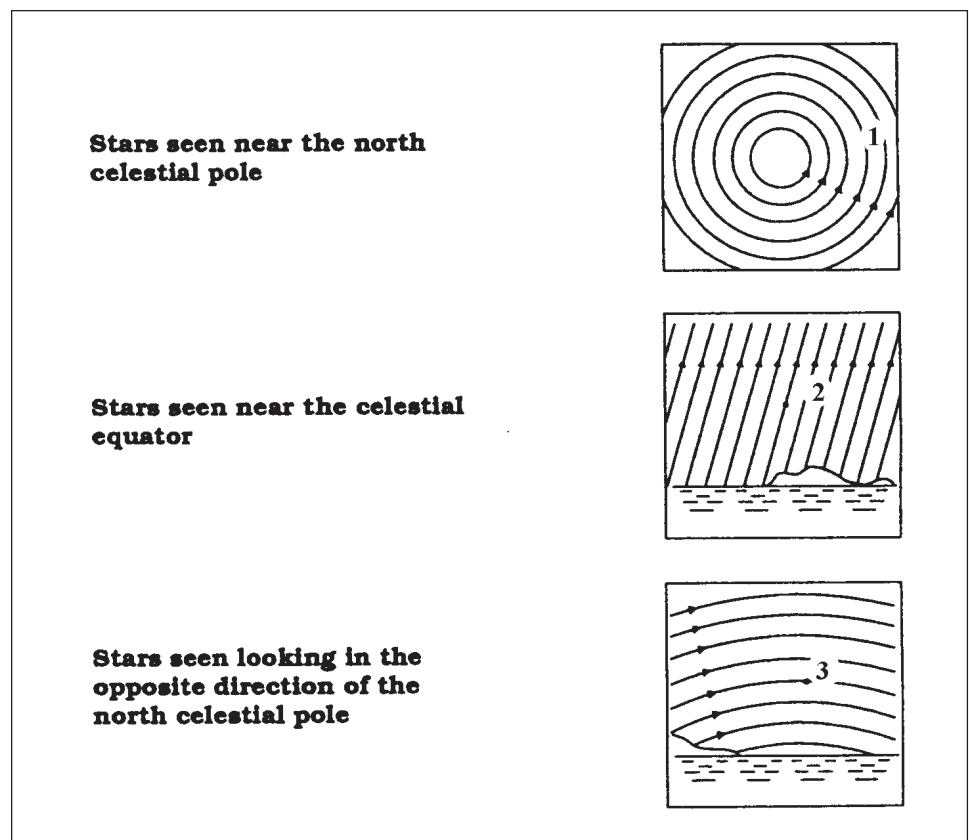

Figure 5-2

All stars appear to rotate around the celestial poles. However, the appearance of this motion varies depending on where you are looking in the sky. Near the north celestial pole the stars scribe out recognizable circles centered on the pole (1). Stars near the celestial equator also follow circular paths around the pole. But, the complete path is interrupted by the horizon. These appear to rise in the east and set in the west (2). Looking toward the opposite pole, stars curve or arc in the opposite direction scribing a circle around the opposite pole (3).

Polar Alignment

In order for the telescope to track the stars it must meet two criteria. First, you need a drive motor that will move at the same rate as the stars. For the CR-150 HD there are two optional motor drives (#93518 and #93523) that can be fitted to it. The second thing you need is to set the telescope's axis of rotation so that it tracks in the right direction. Since the motion of the stars across the sky is caused by the Earth's rotation about its axis, the telescope's axis must be made parallel to the Earth's axis.

Polar alignment is the process by which the telescope's axis of rotation is aligned (made parallel) with the Earth's axis of rotation. Once aligned, a telescope with a clock drive will track the stars as they move across the sky. The result is that objects observed through the telescope will appear stationary (i.e., they will not drift out of the field of view). If your telescope does not use a motor drive, all objects in the sky (day or night) will drift out of the field. This apparent motion is caused by the Earth's rotation. Even if you are not using a motor drive, polar alignment is still desirable since it will reduce the number of corrections needed to follow an object and will limit all corrections to one axis (R.A.). There are several methods of polar alignment, all of which work on a similar principle, but are performed somewhat differently. Each method will be considered separately, beginning with the easier methods and working to the more difficult, but more precise.

Although there are several methods mentioned here, you will never use all of them during one particular observing session. Instead, you may use only one if it is a casual observing session. Or, if you plan on astrophotography, you may use two methods — one for rough alignment followed by a more accurate method.

Definition:

The polar axis is the axis around which the telescope rotates when moving the telescope in right ascension. This axis remains stationary as the telescope moves in right ascension and declination.

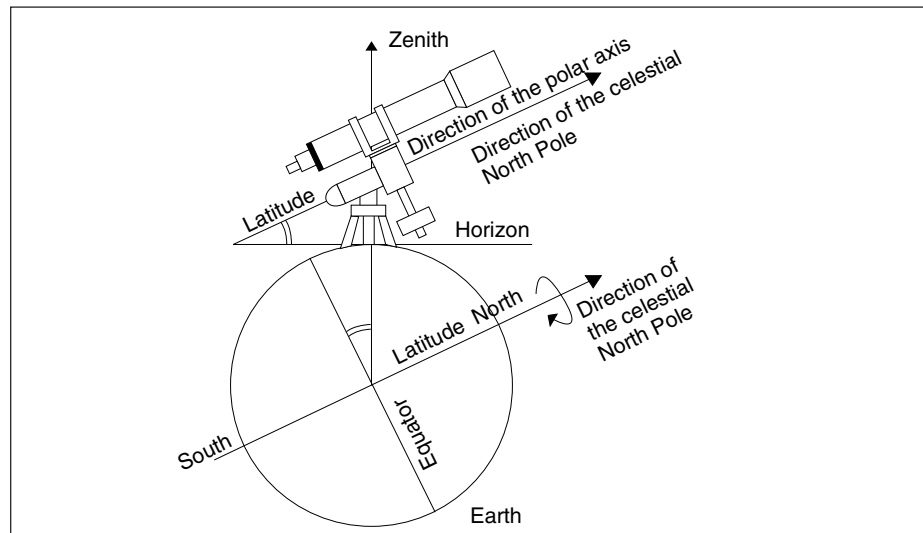

Figure 5-3

When the telescope's axis of rotation is parallel to the Earth's axis, stars viewed through the telescope appear stationary when using a motor drive.

Finding the Pole

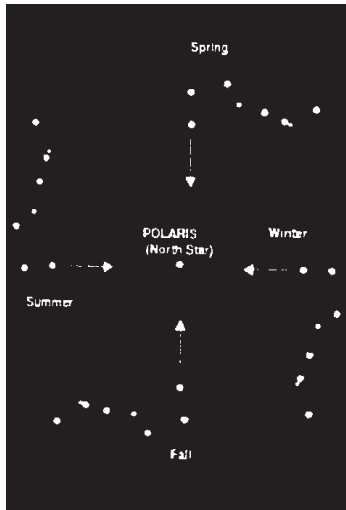

Figure 5-4

The position of the Big Dipper changes throughout the year and throughout the night.

Definition:

For each hemisphere, there is a point in the sky around which all the other stars appear to rotate. These points are called the celestial poles and are named for the hemisphere in which they reside. For example, in the northern hemisphere all stars move around the north celestial pole. When the telescope's polar axis is pointed at the celestial pole, it is parallel to the Earth's rotational axis.

Many of the methods of polar alignment require that you know how to find the celestial pole by identifying stars in the area. For those in the northern hemisphere, finding the celestial pole is relatively easy. Fortunately, we have a naked eye star less than a degree away. This star, Polaris, is the end star in the handle of the Little Dipper (see figure 5-5). Since the Little Dipper (technically called Ursa Minor) is not one of the brightest constellations in the sky, it may be difficult to locate, especially from urban areas. If this is the case, use the two end stars in the bowl of the Big Dipper. Draw an imaginary line through them (about five times the distance between these two stars) toward the Little Dipper. They will point to Polaris. The position of the Big Dipper will change during the year and throughout the course of the night (see figure 5-4). When the Big Dipper is difficult to locate, try using Cassiopeia.

Observers in the southern hemisphere are not as fortunate as those in the northern hemisphere. The stars around the south celestial pole are not nearly as bright as those around the north. The closest star that is relatively bright is Sigma Octantis. This star is just within naked eye limit (magnitude 5.5) and lies 59 arc minutes from the pole. For more information about stars around the south celestial pole, please consult a star atlas.

While it may seem that pointing at the pole star produces a parallax effect, especially for observers near the equator, this effect is negligible since Polaris is so far away.

The north celestial pole is the point in the northern sky around which all stars appear to rotate. The counterpart in the southern hemisphere is referred to as the south celestial pole.

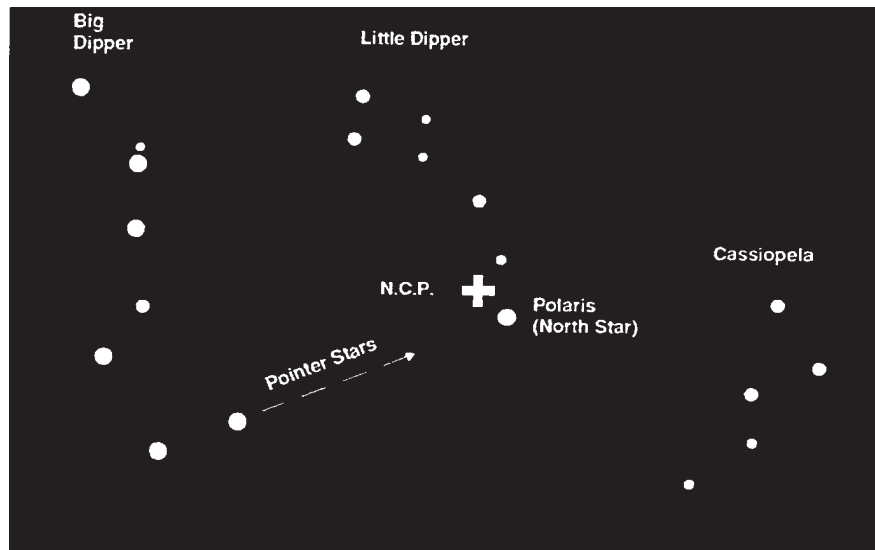

Figure 5-5

The two stars in the front of the bowl of the Big Dipper point to Polaris which is less than one degree from the true (north) celestial pole. Cassiopeia, the "W" shaped constellation is on the opposite side of the pole from the Big Dipper. The North Celestial Pole (N.C.P.) is marked by the "+" sign.

Latitude Scales

The easiest way to polar align a telescope is with a latitude scale. Unlike other methods that require you to find the celestial pole by identifying certain stars near it, this method works off of a known constant (your latitude) to determine how high the polar axis should be pointed. The latitude range varies depending upon the telescope you own. The range for the CG-5 is 40° .

The constant, mentioned above, is a relationship between your latitude and the angular distance the celestial pole is above the northern (or southern) horizon. The angular distance from the northern horizon to the north celestial pole is always equal to your latitude. To illustrate this, imagine that you are standing on the north pole, latitude $+90^\circ$. The north celestial pole, which has a declination of $+90^\circ$, would be directly overhead (i.e., 90° above the horizon). Now let's say that you move one degree south. Your latitude is now $+89^\circ$ and the celestial pole is no longer directly overhead. It has moved one degree closer toward the northern horizon. This means the pole is now 89° above the northern horizon. If you move one degree further south, the same thing happens again. As you can see from this example, the distance from the northern horizon to the celestial pole is always equal to your latitude.

If you are observing from Los Angeles, which has a latitude of 34° , then the celestial pole would be 34° above the northern horizon. All a latitude scale does then is to point the polar axis of the telescope at the right elevation above the northern (or southern) horizon. To align your telescope:

1. Point your telescope due north. Use a landmark that you know faces north.
2. Level the tripod by raising or lowering the legs as needed. There is a bubble level built into the tripod of the CG-5 mount for this purpose.
3. Adjust the telescope mount in altitude until the latitude indicator (see figure 5-6) points to your latitude.

This method can be done in daylight, thus eliminating the need to fumble around in the dark. Although this method does **NOT** put you directly on the pole, it will limit the number of corrections needed when tracking an object. It will also be accurate enough for short exposure prime focus planetary photography (a couple of seconds) and short exposure piggyback astrophotography.

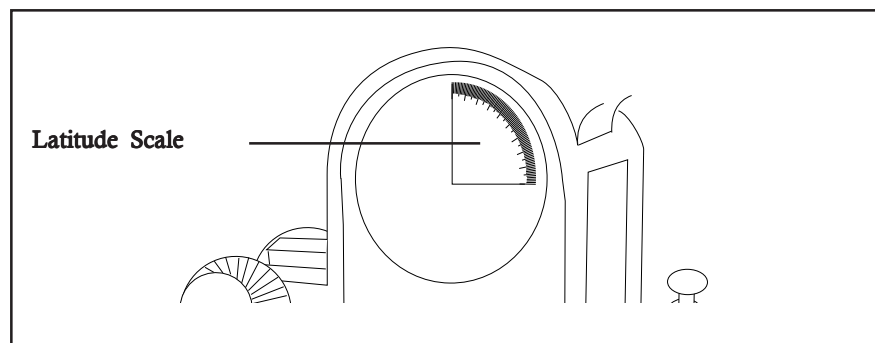

Figure 5-6

Pointing at Polaris

This method utilizes Polaris as a guidepost to the celestial pole. Since Polaris is less than a degree from the celestial pole, many amateurs simply point the polar axis of their telescope at Polaris. Although this is by no means a perfect alignment, it is close. To align using this method:

Align the finderscope with the main optical tube as described in the "Aligning the Finder" section earlier in the manual.

- 1 Set the telescope up so that the polar axis is pointing north and the counterweight shaft is rotated towards the ground.
- 2 Release the DEC clamp and move the telescope so that the optical tube is directly over the polar axis.
- 3 Move the mount in altitude and/or azimuth until Polaris is in the field of view of the finder. Rough azimuth adjustments can be made by moving the tripod.
- 4 Center Polaris using the fine altitude and azimuth controls (see figure 5-7). **Remember, do not move the telescope in R.A. or DEC. You want to adjust the direction the mount is pointing and you are using the telescope to see where the mount is pointing.**
- 5 Once Polaris is in the finder it should also be centered in the telescope. If not, use the fine adjustment controls to center Polaris in the telescope field.
- 6 Rotate the Declination circle, just above the counterweight shaft, to read 90° . Do not move the Declination circle by hand after it is set.

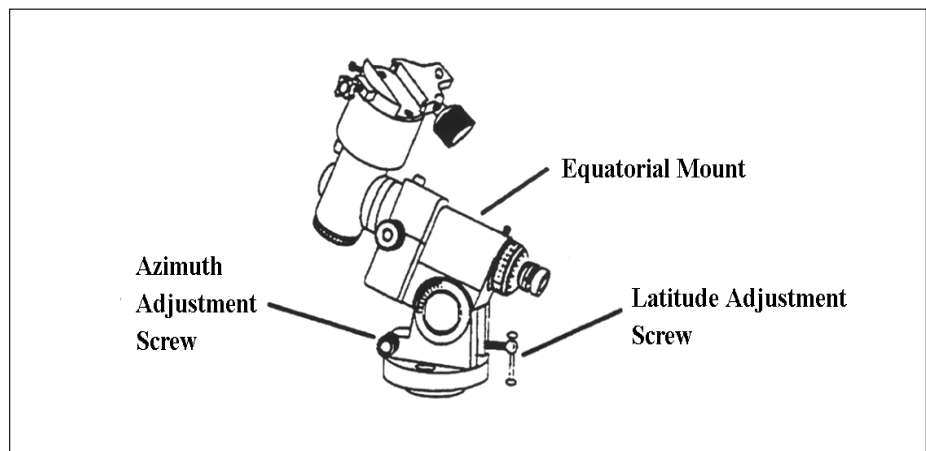

Figure 5-7

Declination Drift

This method of polar alignment allows you to get the most accurate alignment on the celestial pole and is required if you want to do long exposure deep-sky astrophotography through the telescope. The declination drift method requires that you monitor the drift of selected guide stars. The drift of each guide star tells you how far away the polar axis is pointing from the true celestial pole and in what direction. Although declination drift is quite simple and straightforward, it requires a great deal of time and patience to complete when first attempted. The declination drift method should be done after any one of the previously mentioned methods has been completed.

To perform the declination drift method you need to choose two bright stars. One should be near the eastern horizon and one due south near the meridian. Both stars should be near the celestial equator (i.e., 0° declination). You will monitor the drift of each star one at a time and in declination only. While monitoring a star on the meridian, any misalignment in the east-west direction will be revealed. While monitoring a star near the east/west horizon, any misalignment in the north-south direction will be revealed. As for hardware, you will need an illuminated reticle ocular to help you recognize any drift. For very close alignment, a Barlow lens is also recommended since it increases the magnification and reveals any drift faster.

When looking due south with the scope on the side of the mount, insert the diagonal so it points straight up. Insert a cross hair ocular and align the cross hairs to be parallel to declination and right ascension motion.

First choose your star near where the celestial equator and the meridian meet. The star should be approximately $\pm 1/2$ hour of the meridian and ± 5 degrees of the celestial equator. Center the star in the field of your telescope and monitor the drift in declination.

- If the star drifts south, the polar axis is too far east.
- If the star drifts north, the polar axis is too far west.

Make the appropriate adjustments to the polar axis to eliminate any drift. Once you have managed to eliminate all drift, move to the star near the eastern horizon. The star should be 20 degrees above the horizon and ± 5 degrees off of the celestial equator.

- If the star drifts south, the polar axis is too low.
- If the star drifts north, the polar axis is too high.

Once again, make the appropriate adjustments to the polar axis to eliminate any drift. Unfortunately, the latter adjustments interact with the prior adjustments ever so slightly. So, repeat the process again to improve the accuracy checking both axes for minimal drift. Once the drift has been eliminated, the telescope is very accurately aligned. You will now be able to do prime focus deep-sky astrophotography for long periods.

NOTE:

If the eastern horizon is blocked, you may choose a star near the western horizon. However, you will have to reverse the polar high/low error directions. If using this method in the southern hemisphere, the procedure is the same as described above. However, the direction of drift is reversed.

Polar Alignment Finders

There are two finders specifically designed for polar alignment that can be used with the CR-150 HD telescopes. These finders can be purchased as optional accessories for the CR-150 HD. The first finder, known as the 7x50 Polaris finder (#93785-8P), is used as a regular finder.

The second finder is the polar axis finderscope (#94221). Its sole purpose is polar alignment and can NOT be used to find objects in the telescope. Both these finders work on the same principle, but their methods of operation are slightly different. These methods are generally easier than those already described and they are fairly accurate. For more information on both these finderscopes, refer to the Optional Accessories section of this manual or ask for the Celestron accessory catalog (#93685).

Aligning the R.A. Setting Circle

Before you can use the setting circles to find objects in the sky you need to align the R.A. setting circle. The declination setting circle is aligned during the polar alignment process. In order to align the R.A. setting circle you will need to know the names of a few of the brightest stars in the sky. If you don't, they can be learned by using the Celestron Sky Maps (#93722) or consulting a current astronomy magazine. To align the R.A. setting circle:

1. Locate a bright star near the celestial equator. The farther you are from the celestial pole the better your reading on the R.A. setting circle will be. The star you choose to align the setting circle with should be a bright one whose coordinates are known and easy to look up. (For a list of bright stars to align the R.A. setting circle, see the list at the back of this manual.)
2. Center the star in the finder.
3. Look through the main telescope and see if the star is in the field. If not, find it and center it.
4. Start the optional motor drive so that it will track the star. If you are not using a motor drive the star will start to drift out of the field and you will need to center it again before setting the R.A. circle.
5. Look up the coordinates of the star.
6. Rotate the circle until the proper coordinates line up with the R.A. indicator (the zero mark on the vernier scale). The R.A. setting circle should rotate freely.

As mentioned above, the declination setting circle is aligned during the process of polar alignment. There is no need to align it in the same manner as the R.A. setting circle.

Once you have finished this process you are ready to use the setting circles to locate objects in the night sky. See the section on "Using the Setting Circles" for specific information.

With your telescope set up, you are ready to use it for celestial observing. This section covers visual observing of both solar system and deep-sky objects.

Observing the Moon

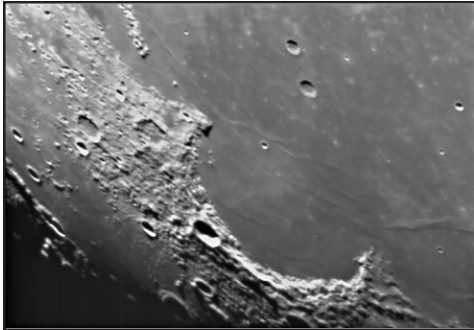

In the night sky, the Moon is a prime target for your first look because it is extremely bright and easy to find. Often, it is a temptation to look at the Moon when it is full. At this time, the face we see is fully illuminated and its light can be overpowering. In addition, little or no contrast can be seen during this phase.

One of the best times to observe the Moon is during its partial phases (around the time of first or third quarter). Long shadows reveal a great amount of detail on the lunar surface. At low power you will be able to see most of the lunar disk at one time. Change to higher power (magnification) to focus in on a smaller area. Keep in mind that if you are not using an optional motor drive, the rotation of the Earth will cause the Moon to drift out of your field of view. You will have to manually adjust the telescope to keep the Moon centered. This effect is more noticeable at higher power.

If you are using a motor drive and have polar aligned, the Moon will remain centered. Consult your local newspaper or a current astronomy magazine to find out when the Moon will be visible. Try using filters to increase contrast and bring out more detail on the lunar surface.

Observing the Planets

Other easy targets in the night sky include the five naked eye planets. You can see Venus go through its lunar-like phases. Mars can reveal a host of surface detail and one, if not both, of its polar caps. You will be able to see the cloud belts of Jupiter and the great Red Spot (if it is visible at the time you are observing). In addition, you will also be able to see the moons of Jupiter as they orbit this gas giant. Saturn with its beautiful ring system and Cassini's division are easily visible at moderate power. All you need to know is where to look. Most astronomy publications tell where the planets can be found in the sky each month.

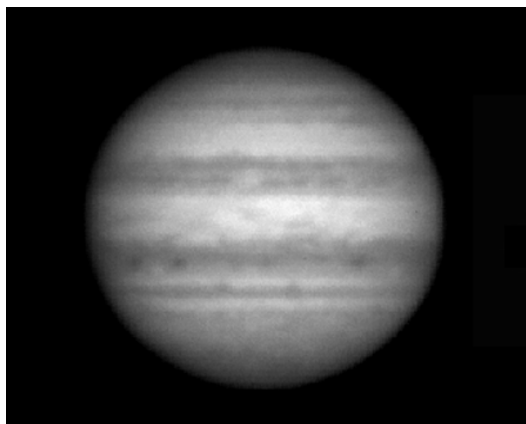

Using the Lens Cap Aperture Stop

As mentioned in the introduction, all refractive optics will exhibit some amount of chromatic aberration due to the prism effect of lenses. Chromatic aberration will become more pronounced the farther the incoming light rays are off-axis (i.e. passing through the edge of the objective lens) and virtually unnoticeable on-axis (passing through the center of the objective lens). This type of aberration is only evident when observing very bright sources of light, such as bright planets and very luminous stars (like Sirius). There are several techniques that the observer can employ to suppress visible signs of chromatic aberration, these include; reducing the aperture and using filters.

The objective lens cap covering the objective lens of the telescope has a built-in 112mm aperture stop in the center. By leaving the lens cap on the telescope with the aperture stop removed, you will allow all the incoming light to pass closer to the center of the optical axis. Since, most planets are extremely bright objects (visible to the unaided eye) any loss of light from reducing the aperture will be unnoticeable.

NOTE: The lens cap should always be completely removed when observing deep-sky objects such as galaxies and nebulae, where aperture (light gathering power) is essential and chromatic aberration is not an issue.

Another useful technique for reducing aberrations and improving planetary detail is the use of colored eyepiece filters. Filters are commonly used to bring out particular planetary detail, such as the polar caps on Mars or the bands and zones around Jupiter. The use of colored filters (especially red and green filters) reduces the effect of chromatic aberration as well as improves contrast and resolution.

Observing the Sun

WARNING:

Although overlooked by many amateur astronomers, solar observation is both rewarding and fun. However, because the Sun is so bright, special precautions must be taken when observing our star so as not to damage your eyes or your telescope.

Never project an image of the Sun through the telescope. Because of the folded optical design, tremendous heat build-up will result inside the optical tube. This can damage the telescope and/or any accessories attached to the telescope.

For safe solar viewing, use a Celestron solar filter. This filter reduces the intensity of the Sun's light, making it safe to view. With this filter you can see sunspots as they move across the solar disk and faculae, which are bright patches seen near the Sun's edge. **Be sure to cover the objective lens of the finder or completely remove the finder when observing the Sun. This will ensure that the finder itself is not damaged and that no one looks through it inadvertently.**

SOLAR OBSERVING HINTS

- The best time to observe the Sun is in the early morning or late afternoon when the air is cooler.
- To locate the Sun without a finder, watch the shadow of the telescope tube until it forms a circular shadow.

Observing Deep-Sky Objects

Deep-sky objects are simply those objects outside the boundaries of our solar system. They include star clusters, planetary nebulae, diffuse nebulae, double stars, and other galaxies outside our own Milky Way. The Celestron Sky Maps (#93722) can help you locate the brightest deep-sky objects.

Most deep-sky objects have a large angular size. Therefore, low-to-moderate power is all you need to see them. Visually, they are too faint to reveal any color seen in long exposure photographs. Instead, they have a black and white appearance. And, because of their low surface brightness, they should be observed from a dark sky location. Light pollution around large urban areas washes out most nebulae making them difficult, if not impossible, to observe. Light Pollution Reduction filters help reduce the background sky brightness, thus increasing contrast.

Using the Setting Circles

Once the setting circles are aligned you can use them to find any object with known coordinates.

1. Select an object to observe. Use a seasonal star chart or planisphere to make sure the object you chose is above the horizon. As you become more familiar with the night sky, this will no longer be necessary.
2. Look up the coordinates in an atlas or reference book.
3. Move the telescope in declination until the indicator is pointing at the correct declination coordinate.
4. Move the telescope in R.A. until the indicator points to the correct coordinate (do NOT move the R.A. circle). The telescope will track in R.A. as long as a motor drive is operating and the R.A. clamp is in the locked position.
5. Look through the finder to see if you have located the object.
6. Center the object in the finder.
7. Look in the main optics using a low power eyepiece; the object should be there. The telescope will track in R.A. as long as the motor drive is operating.
8. Repeat the process for each object observed throughout the observing session.

You may not be able to see fainter objects in the finder. When this happens, gradually sweep the telescope around until the object is visible.

The declination setting circle is scaled in degrees while the R.A. setting circle is incremented in minutes with a marker every fifth minute. As a result, the setting circles will get you close to your target, but not directly on it. Also, the accuracy of your polar alignment will also affect how accurately your setting circles read.

At the end of this manual there is a list of deep-sky objects well within reach of your Celestron telescope.

Star Hopping

You can use your setting circles to find these objects (as described earlier in this manual) or try star hopping. Star hopping is done by using bright stars to guide you to an object. Here are directions for two popular objects.

The Andromeda Galaxy, M31, is an easy first target. To find M31:

1. Locate the constellation of Pegasus, a large square visible in the fall and winter months.
2. Start at the star in the northeast corner. The star is Alpha (α) Andromeda.
3. Move northeast approximately 7° . There you will find two stars of equal brightness — Delta (δ) and Pi (π) Andromeda — about 3° apart.
4. Continue in the same direction another 8° . There you will find two stars — Beta (β) and Mu (μ) Andromeda — about 3° apart.
5. Move 3° northwest — the same distance between the two stars — to the Andromeda galaxy. It is easily visible in the finder.

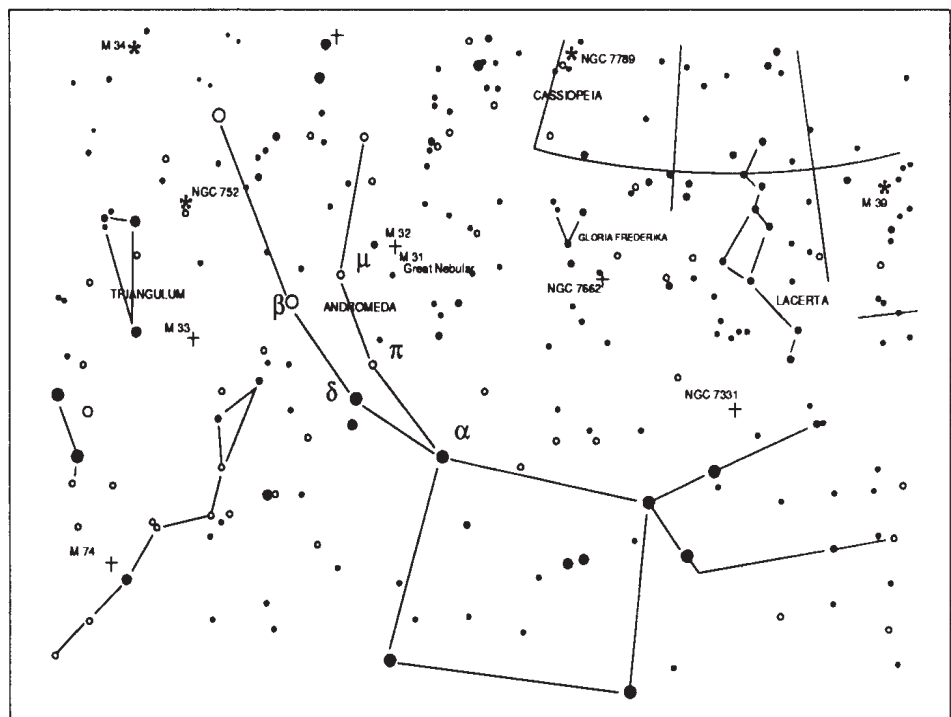

Figure 6-2

Star hopping to the Andromeda Galaxy is a snap to find since all the stars needed to do so are visible to the naked eye. Note that the scale for this star chart is different from the one on the following page which shows the constellation Lyra.

Star hopping may take some getting used to since you can see more stars through the finder than you can see with the naked eye. And, some objects are not visible in the finder. One such object is M57, the famed Ring Nebula. Here's how to find it:

1. Find the constellation of Lyra, a small parallelogram visible in the summer and fall months. Lyra is easy to pick out because it contains the bright star Vega.
2. Start at the star Vega — Alpha (α) Lyrae — and move a few degrees southeast to find the parallelogram. The four stars that make up this geometric shape are all similar in brightness, making them easy to see.
3. Locate the two southern most stars that make up the parallelogram — Beta (β) and Gamma (γ) Lyrae (see figure 6-3).
4. Point the finder half way between these two stars.
5. Move about $1/2^\circ$ toward Beta (β) Lyrae, but remaining on a line that connects the two stars.
6. Look through the telescope and the Ring Nebula should be in the telescope. Its angular size is quite small and, therefore, not visible in the finder.

These two examples should give you an idea of how to star hop to deep-sky objects. To use this method on other objects, consult any of the star atlases listed at the end of this book.

Figure 6-3

Although the Ring Nebula lies between two naked eye stars, it may take a little time to locate since it is not visible in the finder. Note that the scale for this star chart is different from the one on the previous page which shows several constellations including Pegasus, Triangulum, and Andromeda.

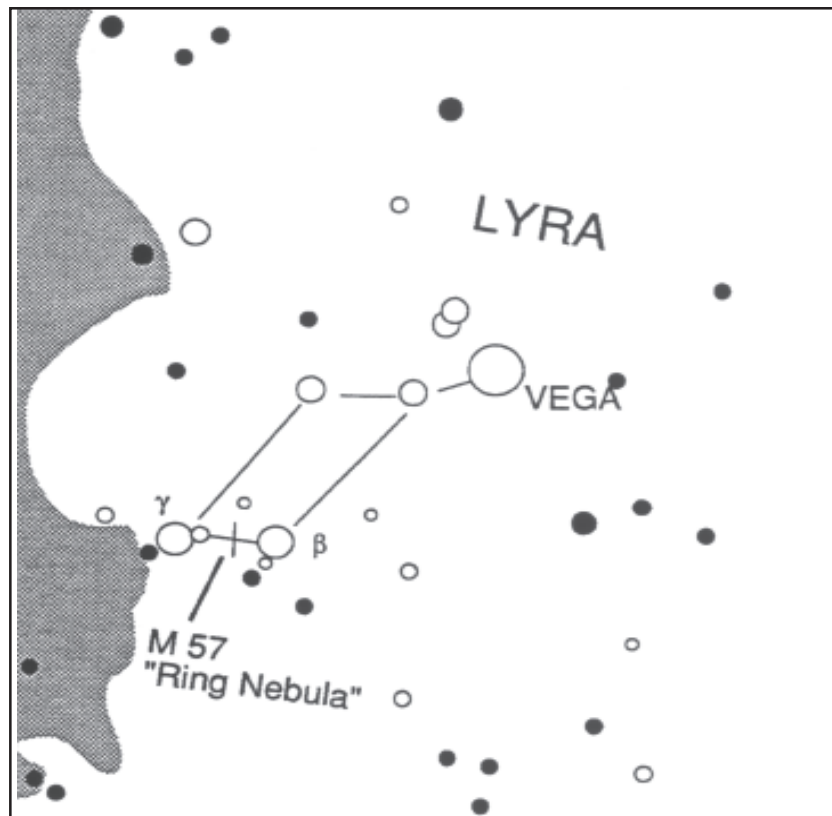

Viewing Conditions

Viewing conditions affect what you can see through your CR-150 HD telescope during an observing session. Conditions include transparency, sky illumination, and seeing. Understanding viewing conditions and the affect they have on observing will help you get the most out of your telescope.

Transparency

Transparency is the clarity of the atmosphere and is affected by clouds, moisture, and other airborne particles. Thick cumulus clouds are completely opaque while cirrus clouds can be thin, allowing the light from the brightest stars through. Hazy skies absorb more light than clear skies making fainter objects harder to see and reducing contrast on brighter objects. Aerosols ejected into the upper atmosphere from volcanic eruptions also affect transparency. Ideal conditions are when the night sky is inky black.

Sky Illumination

General sky brightening caused by the Moon, aurorae, natural airglow, and light pollution greatly affect transparency. While not a problem for the Moon, planets, and brighter stars, bright skies reduce the contrast of extended nebulae making them difficult, if not impossible, to see. To maximize your observing, limit deep-sky viewing to moonless nights far from the light polluted skies found around major urban areas. LPR filters enhance deep-sky viewing from light polluted areas by blocking unwanted light while transmitting light from certain deep-sky objects. You can, on the other hand, observe planets and stars from light polluted areas or when the Moon is out.

Seeing

Seeing conditions refer to the stability of the atmosphere and directly effects the clarity of star images and the amount of fine detail seen in extended objects like the planets. The air in our atmosphere acts as a lens which bends and distorts incoming light rays. The amount of bending depends on air density. Varying temperature layers have different densities and therefore bend light differently. Light rays from the same object arrive slightly displaced creating an imperfect or smeared image. These atmospheric disturbances vary from time-to-time and place-to-place. The size of the air parcels compared to your aperture determines the “seeing” quality. Under good seeing conditions, fine detail is visible on the brighter planets like Jupiter and Mars, and stars are pinpoint images. Under poor seeing conditions, images are blurred and stars appear as blobs. Seeing conditions are rated on a five-point scale where one is the worst and five is the best (see figure 6-4). Seeing conditions can be classified in one of three categories which are based on the cause.

Type 1 seeing conditions are characterized by rapid changes in the image seen through the telescope. Extended objects, like the Moon, appear to shimmer while point sources (i.e., stars) appear double. Type 1 seeing is caused by currents within or very close to the telescope tube. These currents could be caused by a telescope that has not reached thermal equilibrium with the outdoor surroundings, heat waves from people standing near the telescope, or heated dew caps. To avoid the problems associated with Type 1 seeing, allow your telescope approximately 20 to 30 minutes to reach thermal equilibrium.

Once adjusted to the outdoor temperature, don't touch the telescope tube with your hands. When pointing the telescope, hold the telescope by the star diagonal. If observing with others, make sure no one stands in front of or directly below the telescope tube.

The images produced by Type 2 seeing conditions don't move as quickly as those produced by Type 1 conditions, but the images are quite blurry. Fine detail is lost and the contrast is low for extended objects. Stars are spread out and not sharp. The source of Type 2 seeing is the lower atmosphere, most likely heat waves from the ground or buildings. To avoid the problems associated with Type 2 seeing, select a good observing site. Specifically, avoid sites that overlook asphalt parking lots or ploughed fields. Stay away from valleys and shorelines. Instead, look for broad hilltops or open grassy fields. Stable thermal conditions found near lakes and atmospheric inversions also tend to produce good seeing. If you can't get a better location, wait until the early morning hours when the surroundings are uniformly cool and the seeing is generally better.

Type 3 seeing conditions are characterized by fast ripples, but sharp images. In extended objects fine detail is visible, but the images shift around the field. Stars are crisp points, but they shift small distances rapidly around the field. The cause of Type 3 seeing is turbulence in the upper atmosphere which means the observer has less control over it. However, the effects of Type 3 seeing are generally less pronounced than the other two types. You can never really avoid Type 3 seeing. Your best bet is to wait until moments of steadiness. If the seeing is extremely bad, pack up and wait for a better night.

The conditions described here apply to both visual and photographic observations.



Figure 6-4

Seeing conditions directly affect image quality. These drawings represent a point source (i.e., star) under bad seeing conditions (left) to excellent conditions (right). Most often, seeing conditions produce images that lie somewhere between these two extremes.

After looking at the night sky for awhile you may want to try photographing it. Several forms of celestial photography are possible with your Celestron CR-150 HD telescope. The most common forms of celestial photography, in order of difficulty are: short exposure prime focus, piggyback, and projection photography. Each of these is discussed in moderate detail with enough information to get you started. Topics include the accessories required and some simple techniques. More information is available in some of the publications listed at the end of this manual.

In addition to the specific accessories required for each type of celestial photography, there is the need for a camera — but not just any camera. The camera does not have to have many of the features offered on today's state-of-the-art equipment. For example, you don't need auto focus capability or mirror lock up. Here are the mandatory features a camera needs for celestial photography. First, a 'B' setting which allows for time exposures. This excludes point and shoot cameras and limits the selection to 35mm SLR cameras.

Second, the 'B' or manual setting should not run off the battery. Many new electronic cameras use the battery to keep the shutter open during time exposures. Once the batteries are drained, usually after a few minutes, the shutter closes, whether you have finished with the exposure or not. Look for a camera that has a manual shutter when operating in the time exposure mode. Olympus, Nikon, Minolta, Pentax, Canon and others have made such camera bodies.

The camera should have interchangeable lenses so you can attach it to the telescope and use a variety of lenses for piggyback photography. If you can't find a new camera, you can purchase a used camera body that is not 100 percent functional. The light meter does not have to be operational since you will be determining the exposure length manually.

Use a cable release with a locking function to hold the shutter open while you do other things. Mechanical and air releases are available at most camera stores.

Short Exposure Prime Focus

Short exposure prime focus photography is the best way to begin recording celestial objects. It is done with the camera attached to the telescope without an eyepiece or camera lens in place. To attach your camera, you need the T-adapter and a T-Ring for your specific camera (i.e., Minolta, Nikon, Pentax, etc.). The CR-150 HD focuser has a built-in T-adapter and is ready to accept a 35mm camera body. The T-Ring replaces the 35mm SLR camera's normal lens. Prime focus photography allows you to capture the entire solar disk (if using the proper filter) as well as the entire lunar disk. To attach your camera to your telescope:

- 1 Remove the eyepiece from the 1 1/4" eyepiece holder.
- 2 Unthread the 1 1/4" accessory adapter from the focuser assembly. This will expose the male thread of the built-in T-adapter.
- 3 Thread the T-ring onto the exposed T-adapter threads.
- 4 Mount your camera body onto the T-Ring the same as you would any other lens.

With your camera attached to the telescope, you are ready for prime focus photography. Start with an easy object like the Moon. Here's how to do it:

1. Load your camera with film that has a moderate-to-fast speed (i.e., ISO rating). Faster films are more desirable when the Moon is a crescent. When the Moon is near full, and at its brightest, slower films are more desirable. Here are some film recommendations:
 - T-Max 100
 - T-Max 400
 - Any 100 to 400 ISO color slide film
 - Fuji Super HG 400
2. Center the Moon in the field of your telescope.
3. Focus the telescope by turning the focus knob until the image is sharp.
4. Set the shutter speed to the appropriate setting (see table 6-1).
5. Trip the shutter using a cable release.
6. Advance the film and repeat the process.

Lunar Phase	ISO 50	ISO 100	ISO 200	ISO 400
Crescent	1/2	1/4	1/8	1/15
Quarter	1/15	1/30	1/60	1/125
Full	1/30	1/60	1/125	1/250

Table 7-1

Above is a listing of recommended exposure times when photographing the Moon at the prime focus of your Celestron telescope.

The exposure times listed here should be used as a starting point. Always make exposures that are longer and shorter than the recommended time. Also, try bracketing your exposures, taking a few photos at each shutter speed. This will ensure that you will get a good photo. If using black and white film, try a yellow filter to reduce the light intensity and to increase contrast.

Keep accurate records of your exposures. This information is useful if you want to repeat your results or if you want to submit some of your photos to various astronomy magazines for possible publication!

This technique is also used for photographing the Sun with the proper solar filter.

Piggyback

The easiest way to enter the realm of deep-sky, long exposure astrophotography is via the piggyback method. Piggyback photography is done with a camera and its normal lens riding on top of the telescope. Through piggyback photography you can capture entire constellations and record large scale nebulae that are too big for prime focus photography. Because you are photographing with a low power lens and guiding with a high power telescope, the margin for error is very large. Small mistakes made while guiding the telescope will not show up on film. To attach the camera to the top of the telescope, thread the bottom of the camera body onto the 1/4"-20 photographic adapter bolt located on the top of the telescope tube clamping ring. In order to guide the exposure, you will also need an optional motor drive (#93518 or #93523).

As with any form of deep-sky photography, it should be done from a dark sky observing site. Light pollution around major urban areas washes out the faint light of deep-sky objects. You can still practice from less ideal skies.

1. Polar align the telescope (using one of the methods described earlier) and start the motor drive.
2. Load your camera with slide film, ISO 100 or faster, or print film, ISO 400 or faster!
3. Set the f/ratio of your camera lens so that it is a half stop to one full stop down from completely open.
4. Set the shutter speed to the "B" setting and focus the lens to the infinity setting.
5. Locate the area of the sky that you want to photograph and move the telescope so that it points in that direction.
6. Find a suitable guide star in the telescope eyepiece field of view. This is relatively easy since you can search a wide area without affecting the area covered by your camera lens. If you do not have an illuminated cross hair eyepiece for guiding, simply defocus your guide star until it fills most of the field of view. This makes it easy to detect any drift.
7. Release the shutter using a cable release.
8. Monitor your guide star for the duration of the exposure making the necessary corrections needed to keep the star centered.
9. Close the camera's shutter.

As for lenses, use good ones that produce sharp images near the edge of the field. The lenses should have a resolving power of at least 40 lines per millimeter. A good focal length range is 50 to 500mm for lenses designed for 35mm cameras.

The exposure time depends on the film being used. However, five minutes is usually a good starting point. With slower films, like 100 ISO, you can expose as long as 45 minutes. With faster films, like 1600 ISO, you really shouldn't expose more than 5 to 10 minutes. When getting started, use fast films to record as much detail in the shortest possible time. Here are proven recommendations:

- Ektar 1000 (color print)
- Konica 3200 (color print)
- Fujichrome 1600D (color slide)
- 3M 1000 (color slide)
- T-Max 3200 (black and white print)
- T-Max 400 (black and white print)

As you perfect your technique, try specialized films, that is films that are designed or specially treated for celestial photography. Here are some popular choices:

- Ektar 125 (color print)
- Fujichrome 100D (color slide)
- Tech Pan, gas hypered (black and white print)

As with all forms of photography, keep accurate records of your work. This information can be used later if you want to reproduce certain results or if you want to submit photos for possible publication.

Once you have mastered piggyback photography with wide angle and normal lenses, try longer focal length lenses. The longer the focal length, the more accurate your guiding must be. You can continue to increase the focal length of the lens until you are ready for prime focus photography with your telescope.

Projection Photography

This form of celestial photography is designed for objects with small angular sizes, primarily the planets and individual lunar features. Planets, although physically quite large, appear small in angular size because of their great distances. Moderate to high magnification is, therefore, required to make the image large enough to see any detail. Unfortunately, the camera/telescope combination alone does not provide enough magnification to produce a usable image size on film. In order to get the image large enough, you must attach your camera to the telescope with a projection lens in place. This can be accomplished with the use of the 2x barlow lens / T-adapter. Slide the 1 1/4" barrel of the barlow lens directly into the focuser and secure with the chrome set screw. Then attach the T-ring for your particular camera make (i.e., Minolta, Nikon, Pentax, etc.) and camera body to the T-adapter.

Because of the higher magnifications during projection photography, the field of view is smaller which makes it more difficult to find and center objects. To make the job a little easier, align the finder as accurately as possible. This allows you to get the object in the field based on the finder's view alone.

Another problem introduced by the higher magnification is vibration. Simply tripping the shutter — even with a cable release — produces enough vibration to smear the image. To get around this, use the camera's self-timer if the exposure time is less than one second — a common occurrence when photographing the Moon. For exposures over one second, use the "hat trick." This technique incorporates a hand-held black card placed over the aperture of the telescope to act as a shutter. The card prevents light from entering the telescope while the shutter is released. Once the shutter has been released and the vibration has diminished (a few seconds), move the black card out of the way to expose the film. After the exposure is complete, place the card over the front of the telescope and close the shutter. Advance the film and you're ready for your next shot. Keep in mind that the card should be held a few inches in front of the telescope, and not touching it. It is easier if you use two people for this process; one to release the camera shutter and one to hold the card. Here's the process for making the exposure.

1. Find and center the desired target in the view finder of your camera.
2. Turn the focus knob until the image is as sharp as possible.
3. Place the black card over the front of the telescope.
4. Release the shutter using a cable release.
5. Wait for the vibration caused by releasing the shutter to diminish. Also, wait for a moment of good seeing.
6. Remove the black card from in front of the telescope for the duration of the exposure.
7. Replace the black card over the front of the telescope.
8. Close the camera's shutter.

Advance the film and you are ready for your next exposure. Don't forget to take photos of varying duration and keep accurate records of what you have done. Record the date, telescope, exposure duration, eyepiece, f/ratio, film, and some comments on the seeing conditions.

TELESCOPE MAINTENANCE

Refractors are generally very low maintenance telescopes. Cleaning is really all that is needed, and even that is minimal if the telescope is stored properly.

Care and Cleaning of the Optics

Occasionally, dust and/or moisture may build up on the objective lens of your telescope. Special care should be taken when cleaning any instrument so as not to damage the optics. If dust has built up on the objective lens, remove dust with a camel's hair brush or a can of pressurized air. Spray at an angle to the lens for approximately 2 to 4 seconds. Then, use optical cleaning solution and white tissue paper to remove any remaining debris. Strokes should go from the center of the objective lens to the outer portion. Do **NOT** rub in circles! With refractive lenses, never apply the cleaning solution directly to the lens. Because the elements are air-spaced, excess solution may seep between the lenses. Apply the solution to the tissue, then the tissue to the lens.

You can use commercially made lens cleaner or mix your own. A good cleaning solution is isopropyl alcohol mixed with distilled water. The solution should be 60% isopropyl alcohol and 40% distilled water. Or, liquid dish soap diluted with water (a couple of drops per one quart of water) can be used.

Occasionally, you may experience dew build-up on the objective lens of your telescope during an observing session. This may be removed with a hair dryer or by pointing the telescope at the ground. Since your Celestron refractor has a built-in dew cap, the dewing process is slightly reduced. If moisture condenses on the inside of the lens, remove the accessories from the telescope. Place the telescope in a dust-free environment and point it down. This will remove the moisture from the telescope tube.

To minimize the need to clean your telescope, replace all lens covers once you have finished using it. Since the back of the telescope where the accessories attach is **NOT** sealed, the plastic cap should be placed over the opening when not in use. This will prevent contaminants from entering the optical tube.

OPTIONAL ACCESSORIES

The following is a partial list of optional accessories available for your Celestron CR-150HD.



CD-ROM (93700) - Celestron and Software Bisque have joined together to present this comprehensive CD-ROM called *The Sky™ Level 1 - for Celestron*. It features a 10,000 object database, 75 color images, horizontal projection, custom sky chart printing, zoom capability and more! A fun, useful and educational product. PC format.

Dual Axis Drive System - #93523

This drive motor, with drive corrector capabilities, is designed for Celestron's CG-5 Equatorial telescope mount. It precisely controls the telescope's tracking speed during timed exposures astrophotography of celestial objects, producing the best possible image sharpness. This precision, state-of-the-art DC motor drive operates on a 9 volt battery. The hand controller module is very compact and fits easily in the palm of your hand. Motors for both axes are included, along with brackets, clutches and hardware.

Erect Image Diagonal (#94112-A) - This accessory is an Amici prism arrangement that allows you to look into the telescope at a 45° angle with images that are oriented properly (upright and correct from left-to-right). It is useful for daytime, terrestrial viewing.

Eyepieces - Like telescopes, eyepieces come in a variety of designs. Each design has its own advantages and disadvantages. For the 1-1/4" barrel diameter there are four different eyepiece designs available.



- **Super Modified Achromatic (SMA) Eyepieces:**

The SMA design is an improved version of the Kellner eyepiece. SMAs are very good, economical, general purpose eyepieces that deliver a wide apparent field, good color correction and an excellent image at the center of the field of view. Celestron offers SMA eyepieces in the following focal lengths: 6mm, 10mm, 12mm, 17mm and 25mm.

- **Plössl** - Plössl eyepieces have a 4-element lens designed for low-to-high power observing. The Plössls offer razor sharp views across the entire field, even at the edges! In the 1-1/4" barrel diameter, they are available in the following focal lengths: 6.3mm, 7.5mm, 10mm, 12.5mm, 17mm, 20mm, 26mm, 32mm and 40mm.

- **Ultima** - Ultima is not really a design, but a trade name for our 5-element, wide field eyepieces. They are available in the following focal lengths: 5mm, 7.5mm, 12.5mm, 18mm, 30mm, 35mm, and 42mm. These eyepieces are all parfocal. The 35mm Ultima gives the widest possible field of view with a 1-1/4" diagonal.

- **Lanthanum Eyepieces (LV Series)** - Lanthanum is a unique rare earth glass used in one of the field lenses of this new eyepiece. The Lanthanum glass reduces aberrations to a minimum. All are fully multicoated and have an astounding 20mm of eye relief — perfect for eyeglass wearers! They are available in the following focal lengths: 2.5mm, 4mm, 5mm, 6mm, 9mm, 10mm, 12mm and 15mm. Celestron also offers the LV Zoom eyepiece (#3777) with a focal length of 8mm to 24mm. It offers an apparent field of 40° at 24mm and 60° at 8mm. Eye relief ranges from 15mm to 19mm.



Eyepiece Filters - To enhance your visual observations of solar system objects, Celestron offers a wide range of colored filters that thread into the 1-1/4" oculars. Available individually are: #12 deep yellow, #21 orange, #25 red, #58 green, #80A light blue, #96 neutral density - 25%T, #96 neutral density - 13%T, and polarizing. These and other filters are also sold in sets.

Finderscopes - Finderscopes are used to help you locate objects in the main telescope. The larger the finder, the more you will see, making it easier to locate objects. One option for finders is the illuminated Polaris 7x50 Finder (#93785-8P). Another tool for finding objects in the sky is the **Star Pointer (#51630)**. The Star Pointer is different from a finderscope in that you can use both eyes when pointing the telescope at an object. A partially reflective surface projects the image of an LED illuminated pinpoint into the line of sight. Just align the illuminated pinpoint with the object you are interested in and the object will be in the main telescope.

Night Vision Flashlight - (#93588) - Celestron's premium model for astronomy, using two red LEDs to preserve night vision better than red filters or other devices. Brightness is adjustable. Operates on a single 9 volt battery (included).

Light Pollution Reduction (LPR) Filters - The 1 1/4" eyepiece filter is designed to enhance your views of deep sky astronomical objects when viewed from urban areas. LPR Filters selectively reduce the transmission of certain wavelengths of light, specifically those produced by artificial lights. This includes mercury and high and low pressure sodium vapor lights. In addition, it also block unwanted natural light (sky glow) caused by neutral oxygen emission in our atmosphere.

Micro Guide Eyepiece (#94171) - This multipurpose 12.5mm illuminated reticle can be used for guiding deep-sky astrophotos, measuring position angles, angular separations, and more. The laser etched reticle provides razor sharp lines and the variable brightness illuminator is completely cordless. The micro guide eyepiece produces 96 power when used with the CR-150 HD at f/8.

Moon Filter (94119-A) - Celestron's Moon Filter is an economical eyepiece filter for reducing the brightness of the moon and improving contrast, so greater detail can be observed on the lunar surface. The clear aperture is 21mm and the transmission is about 18%.

Motor Drive System - #93518

By adding the MDCG-5 Drive System to your mount, you add the capacity to *automatically* track objects in the sky, a convenience you'll be sure to enjoy during long viewing or astrophotography sessions, when manual tracking can become tiring. Furthermore, the Drive System will enhance high-power visual observing. It attaches to the R.A. (east/west) drive axis of your CG-5 Mount and will drive the telescope at the normal sidereal rate as well as allowing you to guide at 2x and 4x sidereal. Power is supplied via a DC battery pack.

Planisphere (93720) - A simple and inexpensive tool for all levels of observers, from naked eye viewers to users of highly sophisticated telescopes. The Celestron Planisphere makes it easy to locate stars for observing and is a great planet finder as well. A map of the night sky, oriented by month and day, rotates within a depiction of the 24 hours of the day, to display exactly which stars and planets will be visible at any given time. Ingeniously simple to use, yet quite effective. Made of durable materials and coated for added protection. Celestron Planispheres come in three different models, to match the latitude from which you're observing:

For 20° to 40° of latitude	93720-30
For 30° to 50° of latitude	93720-40
For 40° to 60° of latitude	93720-50

Polarizing Filter Set (#93608) - The polarizing filter set limits the transmission of light to a specific plane, thus increasing contrast between various objects. This is used primarily for terrestrial, lunar and planetary observing.

Polar Axis Finderscope (#94221) - This useful accessory speeds accurate polar alignment by providing a means of visually aligning your German equatorial mount with Polaris and true north. The finderscope has an eyepiece with etched reticle for quick polar alignment.

Sky Maps (#93722) - Celestron Sky Maps are the ideal teaching guide for learning the night sky. You wouldn't set off on a road trip without a road map, and you don't need to try to navigate the night sky without a map either. Even if you already know your way around the major constellations, these maps can help you locate all kinds of fascinating objects.

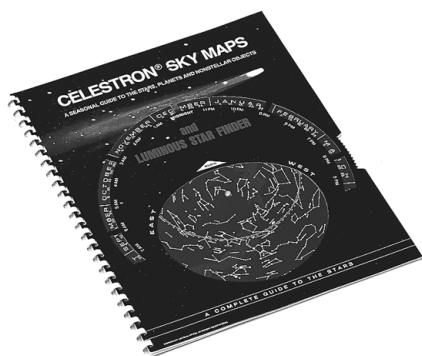

T-Ring - The T-Ring couples your 35mm SLR camera body to the T-Adapter, Radial Guider, or Tele-extender. This accessory is mandatory if you want to do photography through the telescope. Each camera make (i.e., Minolta, Nikon, Pentax, etc.) has its own unique mount and therefore, its own T-Ring. Celestron has 8 different models for 35mm cameras.

A full description of all Celestron accessories can be found in the Celestron accessory catalog (#93685).

THE MESSIER CATALOG

The Messier Catalog, compiled by Charles Messier, was the first extensive listing of star clusters and nebulae. Messier's primary observational purpose was to discover comets. He compiled this list so that others searching for comets would not be confused by these objects. His list still remains popular today because all of these objects are easily visible in amateur telescopes.

M#	NGC#	Const.	R.A. H M S	DEC ° ' "	Mag	Type	Proper Name
M1	NGC 1952	Tau	5 34.5	22 01	8.4	P. Neb.	Crab Nebula
M2	NGC 7089	Aqr	21 33.5	-00 49	6.5	Gl. Cl.	
M3	NGC 5272	CVn	13 42.2	28 23	6.4	Gl. Cl.	
M4	NGC 6121	Sco	16 23.6	-26 32	5.9	Gl. Cl.	
M5	NGC 5904	Ser	15 18.5	2 05	5.8	Gl. Cl.	
M6	NGC 6405	Sco	17 40.0	-32 13	4.2	Op. Cl.	Butterfly Cluster
M7	NGC 6475	Sco	17 54.0	-34 49	3.3	Op. Cl.	
M8	NGC 6523	Sgr	18 03.7	-24 23	5.8	D. Neb.	Lagoon Nebula
M9	NGC 6333	Oph	17 19.2	-18 31	7.9	Gl. Cl.	
M10	NGC 6254	Oph	16 57.2	-4 06	6.6	Gl. Cl.	
M11	NGC 6705	Sct	18 51.1	-6 16	5.8	Op. Cl.	Wild Duck Cluster
M12	NGC 6218	Oph	16 47.2	-1 57	6.6	Gl. Cl.	
M13	NGC 6205	Her	16 41.7	36 28	5.9	Gl. Cl.	Hercules Cluster
M14	NGC 6402	Oph	17 37.6	-3 15	7.6	Gl. Cl.	
M15	NGC 7078	Peg	21 30.0	12 10	6.4	Gl. Cl.	
M16	NGC 6611	Ser	18 18.9	-13 47	6.0	D. Neb.	Eagle Nebula
M17	NGC 6618	Sgr	18 20.8	-16 11	7.0	D. Neb.	Omega Nebula
M18	NGC 6613	Sgr	18 19.9	-17 08	6.9	Op. Cl.	
M19	NGC 6273	Oph	17 02.6	-26 16	7.2	Gl. Cl.	
M20	NGC 6514	Sgr	18 02.4	-23 02	8.5	D. Neb.	Trifid Nebula
M21	NGC 6531	Sgr	18 04.7	-22 30	5.9	Op. Cl.	
M22	NGC 6656	Sgr	18 36.4	-23 54	5.1	Gl. Cl.	
M23	NGC 6494	Sgr	17 56.9	-19 01	5.5	Op. Cl.	
M24	NGC 6603	Sgr	18 16.4	-18 29	4.5	Op. Cl.	
M25	IC 4725	Sgr	18 31.7	-19 15	4.6	Op. Cl.	
M26	NGC 6694	Sct	18 45.2	-9 24	8.0	Op. Cl.	
M27	NGC 6853	Vul	19 59.6	22 43	8.1	P. Neb.	Dumbbell Nebula
M28	NGC 6626	Sgr	18 24.6	-24 52	6.9	Gl. Cl.	
M29	NGC 6913	Cyg	20 23.0	38 32	6.6	Op. Cl.	
M30	NGC 7099	Cap	21 40.4	-23 11	7.5	Gl. Cl.	
M31	NGC 224	And	0 42.7	41 16	3.4	Sp. Gx.	Andromeda Galaxy
M32	NGC 221	And	0 42.7	40 52	8.2	El. Gx.	
M33	NGC 598	Tri	1 33.8	30 39	5.7	Sp. Gx.	Pinwheel Galaxy
M34	NGC 1039	Per	2 42.0	42 47	5.2	Op. Cl.	
M35	NGC 2168	Gem	6 08.8	24 20	5.1	Op. Cl.	

M#	NGC#	Const.	R.A. H M S	DEC ° ' "	Mag	Type	Proper Name
M36	NGC 1960	Aur	5 36.3	34 08	6.0	Op. Cl.	
M37	NGC 2099	Aur	5 52.0	32 33	5.6	Op. Cl.	
M38	NGC 1912	Aur	5 28.7	35 50	6.4	Op. Cl.	
M39	NGC 7092	Cyg	21 32.3	48 26	4.6	Op. Cl.	
M40		UMa	12 22.2	58 05	8.0	dbl	
M41	NGC 2287	CMa	6 47.0	-20 44	4.5	Op. Cl.	
M42	NGC 1976	Ori	5 35.3	-5 27	4.0	D. Neb.	Great Orion Nebula
M43	NGC 1982	Ori	5 35.5	-5 16	9.0	D. Neb.	
M44	NGC 2632	Cnc	8 40.0	19 59	3.1	Op. Cl.	Beehive Cluster
M45		Tau	3 47.5	24 07	1.2	Op. Cl.	Pleiades
M46	NGC 2437	Pup	7 41.8	-14 49	6.1	Op. Cl.	
M47	NGC 2422	Pup	7 36.6	-14 30	4.4	Op. Cl.	
M48	NGC 2548	Hya	8 13.8	-5 48	5.8	Op. Cl.	
M49	NGC 4472	Vir	12 29.8	8 00	8.4	El. Gx.	
M50	NGC 2323	Mon	7 03.0	-8 20	5.9	Op. Cl.	
M51	NGC 5194-5	CVn	13 29.9	47 12	8.1	Sp. Gx.	Whirlpool Galaxy
M52	NGC 7654	Cas	23 24.2	61 35	6.9	Op. Gx.	
M53	NGC 5024	Com	13 12.9	18 10	7.7	Gl. Cl.	
M54	NGC 6715	Sgr	18 55.1	-30 29	7.7	Gl. Cl.	
M55	NGC 6809	Sgr	19 40 .0	-30 58	7.0	Gl. Cl.	
M56	NGC 6779	Lyr	19 16.6	30 11	8.2	Gl. Cl.	
M57	NGC 6720	Lyr	18 53.6	33 02	9.0	P. Neb.	Ring Nebula
M58	NGC 4579	Vir	12 37.7	11 49	9.8	Sp. Gx.	
M59	NGC 4621	Vir	12 42.0	11 39	9.8	El. Gx.	
M60	NGC 4649	Vir	12 43.7	11 33	8.8	El. Gx.	
M61	NGC 4303	Vir	12 21.9	4 28	9.7	Sp. Gx.	
M62	NGC 6266	Oph	17 01.2	-30 07	6.6	Gl. Cl.	
M63	NGC 5055	CVn	13 15.8	42 02	8.6	Sp. Gx.	Sunflower Galaxy
M64	NGC 4826	Com	12 56.7	21 41	8.5	Sp. Gx.	Black Eye Galaxy
M65	NGC 3623	Leo	11 18.9	13 05	9.3	Sp. Gx.	Leo's Triplet
M66	NGC 3627	Leo	11 20.3	12 59	9.0	Sp. Gx.	Leo's Triplet
M67	NGC 2682	Cnc	8 50.3	11 49	6.9	Op. Cl.	
M68	NGC 4590	Hya	12 39.5	-26 45	8.2	Gl. Cl.	
M69	NGC 6637	Sgr	18 31.4	-32 21	7.7	Gl. Cl.	
M70	NGC 6681	Sgr	18 43.2	-32 18	8.1	Gl. Cl.	
M71	NGC 6838	Sge	19 53.7	18 47	8.3	Gl. Cl.	
M72	NGC 6981	Aqr	20 53.5	-12 32	9.4	Gl. Cl.	
M73	NGC 6994	Aqr	20 58.0	-12 38		ast	
M74	NGC 628	Psc	1 36.7	15 47	9.2	S	
M75	NGC 6864	Sgr	20 06.1	-21 55	8.6	Gl. Cl.	
M76	NGC 650-1	Per	1 42.2	51 34	11.5	P. Neb.	Cork Nebula
M77	NGC 1068	Cet	2 42.7	0 01	8.8	Sp. Gx.	
M78	NGC 2068	Ori	5 46.7	0 03	8.0	D. Neb.	
M79	NGC 1904	Lep	5 24.2	-24 33	8.0	Gl. Cl.	
M80	NGC 6093	Sco	16 17.0	-22 59	7.2	Gl. Cl.	

M#	NGC#	Const.	R.A. H M S	DEC ° ‘	Mag	Type	Proper Name
M81	NGC 3031	UMa	9 55.8	69 04	6.8	Sp. Gx.	Bodes Nebula
M82	NGC 3034	UMa	9 56.2	69 41	8.4	Ir. Gx.	
M83	NGC 5236	Hya	13 37.7	-29 52	7.6	Sp. Gx.	
M84	NGC 4374	Vir	12 25.1	12 53	9.3	El. Gx.	
M85	NGC 4382	Com	12 25.4	18 11	9.2	El. Gx.	
M86	NGC 4406	Vir	12 26.2	12 57	9.2	El. Gx.	
M87	NGC 4486	Vir	12 30.8	12 24	8.6	El. Gx.	Virgo A
M88	NGC 4501	Com	12 32.0	14 25	9.5	Sp. Gx.	
M89	NGC 4552	Vir	12 35.7	12 33	9.8	El. Gx.	
M90	NGC 4569	Vir	12 36.8	13 10	9.5	Sp. Gx.	
M91	NGC 4548	Com	12 35.4	14 30	10.2	Sp. Gx.	
M92	NGC 6341	Her	17 17.1	43 08	6.5	Gl. Cl.	
M93	NGC 2447	Pup	7 44.6	-23 52	6.2	Op. Cl.	
M94	NGC 4736	CVn	12 50.9	41 07	8.1	Sp. Gx.	
M95	NGC 3351	Leo	10 44.0	11 42	9.7	Sp. Gx.	
M96	NGC 3368	Leo	10 46.8	11 49	9.2	Sp. Gx.	
M97	NGC 3587	UMa	11 14.9	55 01	11.2	P. Neb.	Owl Nebula
M98	NGC 4192	Com	12 13.8	14 54	10.1	Sp. Gx.	
M99	NGC 4254	Com	12 18.8	14 25	9.8	Sp. Gx.	Pin Wheel Nebula
M100	NGC 4321	Com	12 22.9	15 49	9.4	Sp. Gx.	
M101	NGC 5457	UMa	14 03.2	54 21	7.7	Sp. Gx.	
M102	NGC 5457	UMa	14 03.2	54 21	7.7	dup	
M103	NGC 581	Cas	1 33.1	60 42	7.4	Op. Cl.	
M104	NGC 4594	Vir	12 40.0	-11 37	8.3	Sp. Gx.	Sombrero Galaxy
M105	NGC 3379	Leo	10 47.9	12 35	9.3	El. Gx..	
M106	NGC 4258	CVn	12 19.0	47 18	8.3	Sp. Gx.	
M107	NGC 6171	Oph	16 32.5	-13 03	8.1	Gl. Cl.	
M108	NGC 3556	UMa	11 11.6	55 40	10.0	Sp. Gx.	
M109	NGC 3992	UMa	11 57.7	53 23	9.8	Sp. Gx.	
M110	NGC 205	And	0 40.3	41 41	8.0	El. Gx.	

Object Abbreviations:

- Sp. Gx. Spiral Galaxy
- El. Gx. Elliptical Galaxy
- Ir. Gx. Irregular Galaxy
- Op. Cl. Open Cluster
- Gl. Cl. Globular Cluster
- D. Neb. Diffuse Nebula
- P. Neb. Planetary Nebula

NOTE: All coordinates for the objects in the Messier catalog are listed in epoch 2000.00.

LIST OF BRIGHT STARS

The following is a list of bright stars that can be used to align the R.A. setting circle. All coordinates are in epoch 2000.0.

Star Name	Constellation	Epoch 2000.0		Magnitude
		R.A. H M S	DEC ° ' "	
Sirius	CMa	06 45 09	-16 42 58	-1.47
Canopus	Car	06 23 57	-52 41 44	-0.72
Arcturus	Boo	14 15 40	+19 10 57	-0.72
Rigel Kent.	Cen	14 39 37	-60 50 02	+0.01
Vega	Lyr	18 36 56	+38 47 01	+0.04
Capella	Aur	05 16 41	+45 59 53	+0.05
Rigel	Ori	05 14 32	-08 12 06	+0.14
Procyon	CMi	07 38 18	+05 13 30	+0.37
Betelgeuse	Ori	05 55 10	+07 24 26	+0.41
Achernar	Eri	01 37 43	-57 14 12	+0.60
Hadar	Cen	14 03 49	-60 22 22	+0.63
Altair	Aqi	19 50 47	+08 52 06	+0.77
Aldebaran	Tau	04 35 55	+16 30 33	+0.86
Spica	Vir	13 25 12	-11 09 41	+0.91
Antares	Sco	16 29 24	-26 25 55	+0.92
Fomalhaut	PsA	22 57 39	-29 37 20	+1.15
Pollux	Gem	07 45 19	+28 01 34	+1.16
Deneb	Cyg	20 41 26	+45 16 49	+1.28
Beta Crucis	Cru	12 47 43	-59 41 19	+1.28
Regulus	Leo	10 08 22	+11 58 02	+1.36

FOR FURTHER READING

The following is a list of astronomy books that will further enhance your understanding of the night sky. The books are broken down by classification for easy reference.

Astronomy Texts

Astronomy Now	Pasachoff & Kutner
Cambridge Atlas Of Astronomy	Audouze & Israel
McGraw-Hill Encyclopedia Of Astronomy	Parker
Astronomy-The Evolving Universe	Zeilik

Atlases

Atlas Of Deep Sky Splendors	Vehrenberg
Sky Atlas 2000.0	Tirion
Sky Catalog 2000.0 Vol 1 & 2	Hirshfeld & Sinnott
Uranometria Vol. 1 & 2	Tirion, Rappaport, Lovi
Magnitude 6 Star Atlas	Dickinson, Costanzo, Chaple
NGC 2000.0.....	Sinnott

General Observational Astronomy

The Cambridge Astronomy Guide	Liller & Mayer
A Complete Manual Of Amateur Astronomy	Sherrod
The Guide To Amateur Astronomy	Newton & Teece

Visual Observation

Observational Astronomy For Amateurs	Sidgwick
Astronomical Calendar	Ottewell
Burnham's Celestial Handbook Vols. 1, 2 & 3	Burnham
The Planet Jupiter	Peek
Field Guide To The Stars & Planets	Menzel & Pasachoff
Observe Comets	Edberg & Levy

Astrophotography

Skyshooting	Mayall & Mayall
Astrophotography A Step-by-Step Approach.....	Little
Astrophotography For The Amateur	Covington
Astrophotography	Gordon
Astrophotography II	Martinez
A Manual Of Celestial Photography	King
Manual Of Advanced Celestial Photography	Wallis & Provin
Colours Of The Stars	Malin & Muirden

CELESTRON ONE YEAR WARRANTY

- A. Celestron International (CI) warrants this telescope to be free from defects in materials and workmanship for one year. CI will repair or replace such product or part thereof which, upon inspection by CI, is found to be defective in materials or workmanship. As a condition to the obligation of CI to repair or replace such product, the product must be returned to CI together with proof-of-purchase satisfactory to CI.
- B. The Proper Return Authorization Number must be obtained from CI in advance of return. Call Celestron at (310) 328-9560 to receive the number to be displayed on the outside of your shipping container.

All returns must be accompanied by a written statement setting forth the name, address, and daytime telephone number of the owner, together with a brief description of any claimed defects. Parts or product for which replacement is made shall become the property of CI.

The customer shall be responsible for all costs of transportation and insurance, both to and from the factory of CI, and shall be required to prepay such costs.

CI shall use reasonable efforts to repair or replace any telescope covered by this warranty within thirty days of receipt. In the event repair or replacement shall require more than thirty days, CI shall notify the customer accordingly. CI reserves the right to replace any product which has been discontinued from its product line with a new product of comparable value and function.

This warranty shall be void and of no force of effect in the event a covered product has been modified in design or function, or subjected to abuse, misuse, mishandling or unauthorized repair. Further, product malfunction or deterioration due to normal wear is not covered by this warranty.

CI DISCLAIMS ANY WARRANTIES, EXPRESS OR IMPLIED, WHETHER OF MERCHANTABILITY OF FITNESS FOR A PARTICULAR USE, EXCEPT AS EXPRESSLY SET FORTH HEREIN.

THE SOLE OBLIGATION OF CI UNDER THIS LIMITED WARRANTY SHALL BE TO REPAIR OR REPLACE THE COVERED PRODUCT, IN ACCORDANCE WITH THE TERMS SET FORTH HEREIN. CI EXPRESSLY DISCLAIMS ANY LOST PROFITS, GENERAL, SPECIAL, INDIRECT OR CONSEQUENTIAL DAMAGES WHICH MAY RESULT FROM BREACH OF ANY WARRANTY, OR ARISING OUT OF THE USE OR INABILITY TO USE ANY CI PRODUCT. ANY WARRANTIES WHICH ARE IMPLIED AND WHICH CANNOT BE DISCLAIMED SHALL BE LIMITED IN DURATION TO A TERM OF ONE YEAR FROM THE DATE OF ORIGINAL RETAIL PURCHASE.

Some states do not allow the exclusion or limitation of incidental or consequential damages or limitation on how long an implied warranty lasts, so the above limitations and exclusions may not apply to you.

This warranty gives you specific legal rights, and you may also have other rights which vary from state to state.

CI reserves the right to modify or discontinue, without prior notice to you, any model or style telescope.

If warranty problems arise, or if you need assistance in using your telescope contact:

Celestron International
Customer Service Department
2835 Columbia Street
Torrance, CA 90503
Tel. (310) 328-9560
Fax. (310) 212-5835
Monday-Friday 8AM-4PM PST

This warranty supersedes all other product warranties.

NOTE: This warranty is valid to U.S.A. and Canadian customers who have purchased this product from an Authorized CI Dealer in the U.S.A. or Canada. Warranty outside the U.S.A. and Canada is valid only to customers who purchased from a CI International Distributor or Authorized CI Dealer in the specific country and please contact them for any warranty service.

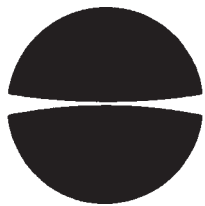

CELESTRON®

Celestron International
2835 Columbia Street
Torrance, CA 90503
Tel: 310-328-9560
Fax: 310-212-5835
Web site: www.celestron.com

Copyright 1999 Celestron International
All right reserved
(Products or instructions may change
without notice or obligation).

Item #21017-INST
10-99
Price \$10.00

Free Manuals Download Website

<http://myh66.com>

<http://usermanuals.us>

<http://www.somanuals.com>

<http://www.4manuals.cc>

<http://www.manual-lib.com>

<http://www.404manual.com>

<http://www.luxmanual.com>

<http://aubethermostatmanual.com>

Golf course search by state

<http://golfingnear.com>

Email search by domain

<http://emailbydomain.com>

Auto manuals search

<http://auto.somanuals.com>

TV manuals search

<http://tv.somanuals.com>