

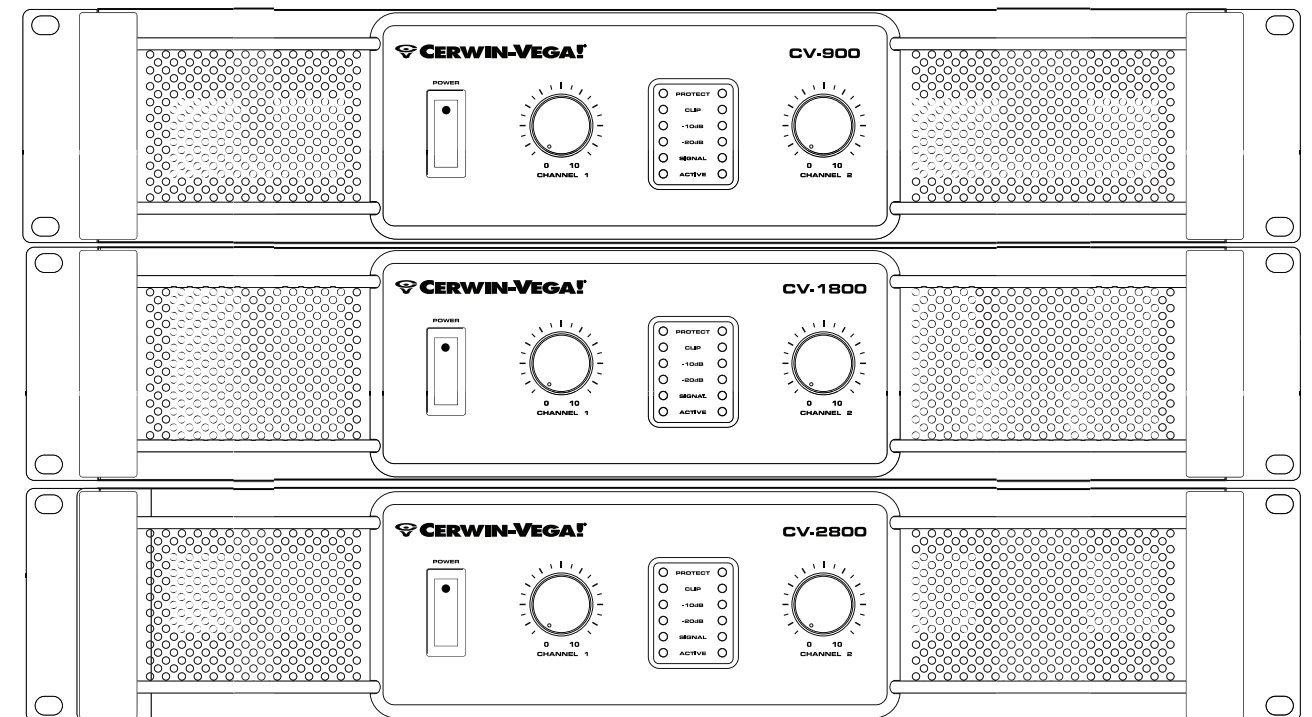





CV-900 / CV-1800 / CV-2800 HEAVY DUTY PROFESSIONAL AMPLIFIERS



USER MANUAL

IMPORTANT SAFETY INSTRUCTIONS

1. Read these instructions - All the safety and operating instructions should be read before this product is operated.
2. Retain these instructions - The safety and operating instructions should be retained for future reference.
3. Heed all warnings - All warnings on the appliance and in the operating instructions should be adhered to.
4. Follow all instructions - All operating and use instructions should be followed.
5. Do not use this apparatus near water - The appliance should not be used near water or moisture - for example, in a wet basement or near a swimming pool, and the like.
6. Clean only with dry cloth.
7. Do not block any ventilation openings. Install in accordance with the manufacturer's instructions.
8. Do not install near any heat sources such as radiators, heat registers, stoves, or other apparatus (including amplifiers) that produce heat.
9. Do not defeat the safety purpose of the polarized or grounding plug. A polarized plug has two blades with one wider than the other. A grounding plug has two blades and a third grounding prong. The wide blade or the third prong is provided for your safety. If the provided plug does not fit into your outlet, consult an electrician for replacement of the obsolete outlet.
10. Protect the power cord from being walked on or pinched particularly at the plugs, convenience receptacles, and at the point where they exit from the apparatus.
11. Only use attachments/accessories specified by the manufacturer.
12. Use only with the cart, stand, tripod, bracket, or table specified by the manufacturer, or sold with the apparatus. When a cart or rack is used, use caution when moving the cart/apparatus combination to avoid injury from tip-over. 
13. Unplug the apparatus during lightning storms or when unused for long periods of time.
14. Refer all servicing to qualified personnel. Servicing is required when the apparatus has been damaged in any way, such as power supply cord or plug is damaged, liquid has been spilled or objects have fallen into the apparatus has been exposed to rain or moisture, does not operate normally, or has been dropped.
15. Please keep the unit in a good ventilation environment.
16. **WARNING:** To reduce the risk of fire or electric shock, do not expose this apparatus to rain or moisture. The apparatus shall not be exposed to dripping or splashing and that no objects filled with liquids, such as vases, shall not be placed on apparatus.
17. **WARNING:** The mains plug or appliance inlet is used as disconnect device, the disconnect device shall remain readily operable.
18. **Power Sources** – This product should be operated only from the type of power source indicated on the rating label. If you are not sure of the type of power supply to your home, consult your product dealer or local power company. For products intended to operate from battery power, or other sources, refer the operating instructions.
19. **Safety Check** – Upon completion of any service or repairs to this product, ask the service technician to perform safety checks to determine that the product is in proper operating condition.
20. Don't touch conductive parts of output terminals to prevent hazardous electrical shock. The external wiring connected to the terminals requires installation by an instructed person or the used of ready-made leads or cords.
21. This equipment is for commercial & professional use only.
22. This product is in compliance with EU WEEE regulations. Disposal of end of life product should not be treated as municipal waste. Please refer to your local regulations for instructions on proper disposal of this product. 
23. To prevent hazardous electrical shock, do not touch the conductive parts of the output terminals. The external wiring connected to the terminals requires installation by a qualified technician or the use of ready made leads or cords. 



Hot danger. Please don't touch the area because a hot danger may exist.



Protective earthing terminal. The apparatus should be connected to a mains socket outlet with a protective earthing connection.



This lightning flash is intended to alert the user to the presence of non-insulated "dangerous voltage" on the output terminals that may be of sufficient magnitude to constitute a risk of electric shock. The external wiring connected to the terminals requires installation by an instructed person or the used of ready-made leads or cords.



CAUTION

RISK OF ELECTRIC SHOCK
DO NOT OPEN



CAUTION: To reduce the risk of electric shock, do not remove any cover. No user-serviceable parts inside. Refer servicing to qualified service personnel only.



The lightning flash with arrowhead symbol within the equilateral triangle is intended to alert the user to the presence of uninsulated "dangerous voltage" within the product's enclosure that may be of sufficient magnitude to constitute a risk of electric shock.



The exclamation point within the equilateral triangle is intended to alert the user to the presence of important operation and maintenance (servicing) instructions in the literature accompanying this appliance.

CAUTION: To prevent electric shock, do not use this polarized plug with an extension cord, receptacle or other outlet unless the blades can be fully inserted to prevent blade exposure.

FRONT PANEL CONTROLS

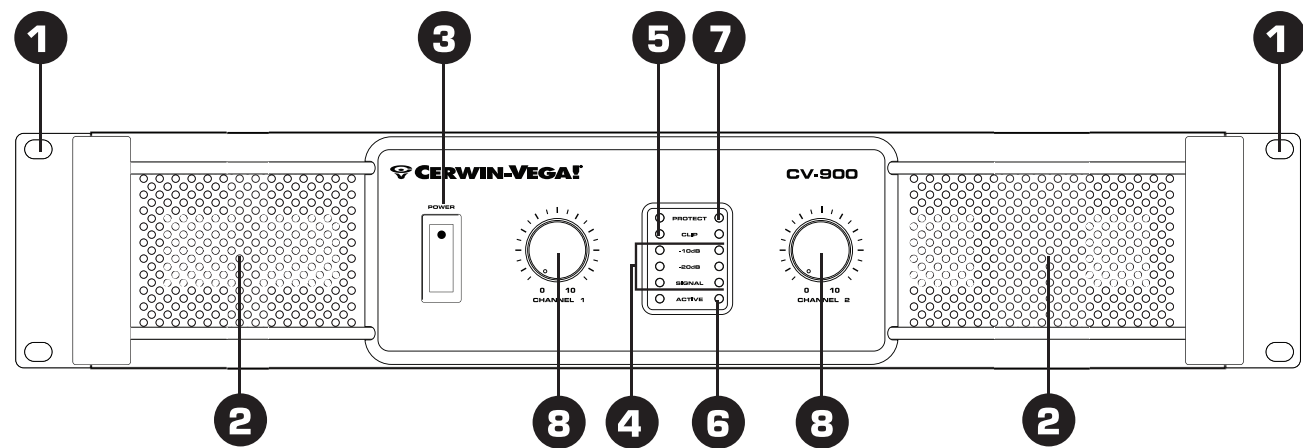

- 1. Rack Ears**
These ears are used to mount the amplifier in any standard 19" rack.
- 2. Fan Vent**
The CV-Series amplifiers are cooled by two rear-mounted fans (except for CV-900 which is cooled by a single rear mounted fan). Cool air flows through the front fan filters, reducing the temperature of internal components while forcing the heat out the rear vents. Never block these vents and keep them clean at all time.
- 3. AC Power Switch**
This switch powers the unit on and off.
- 4. Signal Indicators**
These blue LED's will illuminate to indicate that a signal is present at the amplifier input, and that the signal is being amplified.
- 5. Clip Indicators**
These red LED's will illuminate at the clipping threshold. These lights should not light up during normal use as they indicate signal outside of the amplification range of the amplifier. When a signal is "clipped" and the clip indicator illuminates, it means that the signal is being distorted at the output stage. Prolonged clipping can not only damage your amplifier, but also your speakers, so be careful to monitor the clip indicator during setup and use. If the clip indicator is illuminated then simply lower the channel gain or input signal until the indicator does not light.

- 6. Active Indicators**
These blue LED's indicate that AC power is connected and the amplifier is turned on.
- 7. Protect Indicators**
These red LED's indicate that the channel is in Protect mode. When the channel goes into protect mode all output for that channel will be muted. The protect LED's light when overheating or other severe problems occur. This is to protect any speakers connected to the channel. The LED's also light for approximately five seconds whenever the unit is powered on and fade slowly when the amplifier is powered off.
- 8. Channel input level control**
These two 21-position detented potentiometers adjust input level for their respective amplifier channels. In Bridged Mono Mode, only channel 1 level control is used to adjust signal level. In Parallel Mode, both input level control are used to adjust signal level for their respective amplifier channels. At their fully counter-clockwise position, the signal is attenuated by more than 80dB. At their fully clockwise position, the signal is at maximum gain. When 0 dBu of signal arrives at the input jacks and the Channel input level controls are set to their fully clockwise position, the unit delivers full power output.

NOTES

WARRANTY & RETURN POLICY

Who's covered by this warranty?

Cerwin-Vega's Limited Warranty on professional audio products extends only to the original purchaser as evidenced by the original Bill of Sale and only for the products purchased from authorized Cerwin-Vega dealers. Ten words of advice: retain the original bill of sale in a safe place!

What's covered by this warranty?

Cerwin-Vega warrants that all new professional audio products shall be free from defects in material and workmanship, under normal and proper use. During the warranty period, Cerwin-Vega agrees to repair or replace (at our option) all such defective parts at no charge for labor or materials.

What's Not covered by this warranty?

This Limited Warranty does not apply to defective equipment that: has been altered or repaired by other than factory approved procedures; has been subjected to negligence, misuse or accident; has been damaged by improper line voltage; had its serial number or any part of it altered, defaced, or removed; or has been used in a way that is contrary to Cerwin-Vega's written instructions. Except as provided by statute, this Limited Warranty does not cover losses, consequential or otherwise, resulting from the improper use of, or inability to operate, any Cerwin-Vega product.

How long Does the warranty Extend?

Cerwin-Vega's Limited Warranty extends for a period of (5) years for all non-powered speaker systems and related components and (3) years for all stand-alone power amplifiers and related components from date of purchase as shown on the original Bill of Sale. The warranty period will be extended if the warranty repairs have not been performed due to delays caused by circumstances beyond the control of the original purchaser, or if the warranty repairs did not remedy the defect and the original purchaser notifies Cerwin-Vega or the original dealer or an Authorized Cerwin-Vega Service Center of the failure of the repairs within 30 days after they were completed.

How Do you get warranty Service?

In order to obtain warranty service, contact your original dealer or distributor, or an Authorized Cerwin-Vega Service Center. If, for some reason, you have trouble locating a service representative, contact Cerwin-Vega's Customer Service Department for assistance:

Cerwin-Vega! Customer Service Dept.
P.O. Box 816667
Hollywood, FL 33081

In some cases, the Customer Service Department can solve a service problem without any return of equipment to Cerwin-Vega, thereby avoiding transit delays.

Phone: 954.316.1500 option 5 Fax: 954.316.1590.
E-mail: info@cerwin-vega.com

Now, what if the product must be returned?

If the Customer Service Department determines that the equipment must be returned to Cerwin-Vega for service, a Return Authorization will be issued, and the defective merchandise may be shipped directly to the above address freight prepaid, along with a copy of both the Return Authorization and the original Bill of Sale. The product will be repaired or replaced (at our option) and returned to the original purchaser. Only the return postage will be paid by Cerwin-Vega. Cerwin-Vega will not be responsible for damage occurring in shipment from the original purchaser or due to improper packing materials. Remember to pack all equipment carefully and in the original carton if possible. Additional charges may be added if new packing materials are required for return shipment. **SAVE YOUR ORIGINAL PACKING MATERIALS!**

Other remedies under the law

The exercise of any of the provisions under the Limited Warranty does not affect the protections or remedies of the original purchaser under other laws. If you have additional questions about service, write or call the Customer Service Department. This Limited Warranty applies to all Cerwin-Vega Professional products, and supersedes all previous warranty statements. Cerwin-Vega reserves the right to make changes in product design and specifications at any time.

EXCEPT AS PROVIDED HEREIN AND BY APPLICABLE LAW, CERWIN-VEGA MAKES NO ADDITIONAL REPRESENTATION or WARRANTY OF ANY NATURE WHATSOEVER, EXPRESSED OR IMPLIED, AS TO THE EQUIPMENT, INCLUDING BUT NOT LIMITED TO, THE MERCHANTABILITY, FITNESS FOR A PARTICULAR PURPOSE, DESIGN CONDITION OR WORKMANSHIP OF THE EQUIPMENT, OR THE QUALITY OF THE MATERIAL INCLUDED THEREIN, THIS LIMITED WARRANTY CONSTITUTES THE SOLE AND ENTIRE AGREEMENT BETWEEN CERWIN-VEGA AND THE ORIGINAL PURCHASER

REAR PANEL CONTROLS

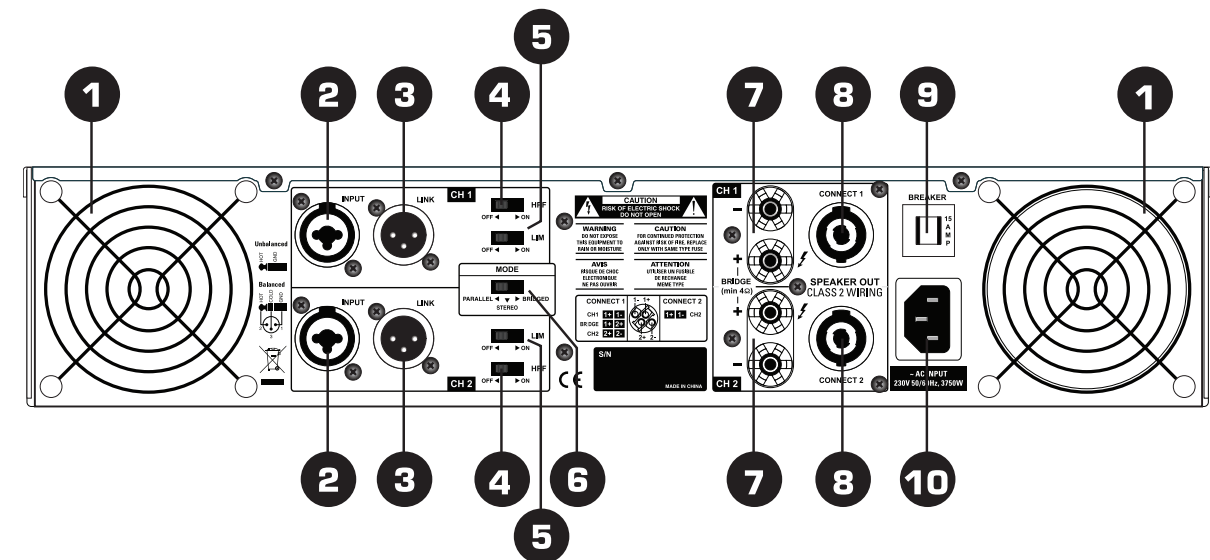

1. Fan

This is a variable speed cooling fan. Cool air enters the amplifier through the fan filters located on the front of the amplifier. Be sure not to block these ports when installing the amplifier or other equipment.

2. Input connectors

Connect the input source to the balanced combo connectors using either XLR or 1/4" TRS plugs. They are configured as follows : Pin 2 (Tip) hot, Pin 3 (Ring) cold, and Pin 1 (Sleeve) ground. We recommend using balanced three-conductor cabling wherever possible. Unbalanced two-conductor 1/4" plugs can also be inserted into these inputs, but you will get better signal quality and less noise and hum if you use balanced lines. Stereo signal should be connected to the Channel 1 and Channel 2 input jacks. When operating the unit in Bridged Mono or Parallel modes, use the Channel 1 input jack only.

3. Link connectors

These jacks are used to send a parallel signal to another device or amplifier.

4. High Pass Filter (HPF) switch.

These switches are used to activate the built-in High Pass Filter. The HPF rolls off signals below 40Hz. This improves bass performance by limiting sub-audio cone motion, making more power available for the speaker's rated frequency range. When the filter is turned off, a 5 Hz roll off protects against DC or deep sub-audio inputs.

5. Limiter switch

When the input signal connected to your amplifier is too high, you end up with a distorted output signal. To prevent this, both channels feature a clip limiter that can be engaged or disengaged selectively.

6. Bridge / Stereo / Parallel switch

This switch changes the amplifier operating mode between stereo, mono bridged, and parallel.

7. 5-way Binding Post

Connect each channel of the unit to your speakers. Binding posts are provided for each channel as well as Speakon® connectors, so that paralleling of speakers is possible. Connection to the binding posts can be made with bare wire, banana plugs, or spade lug terminations. Make connections to both the Channel 1 and Channel 2 terminals for Stereo or Parallel Mode, or a single connection across the red terminals only of Channel 1 and Channel 2 for Bridged Mono Mode.

8. Speakon® output connectors

You can use these to connect each channel of the unit to 8 ohms or 4 ohms loudspeakers. Using Speakon® speaker cables, make connections to both the channel 1 and channel 2 connectors for Stereo or Parallel Mode, or to the Bridged mode connector for Bridged Mono Mode.

9. Circuit breaker

The breaker acts in place of common disposable fuses. This circuit breaker will trip if there is a fault with the main voltage or if maximum output is exceeded. Simply depress the circuit breaker and power up the unit again.

10. AC input

IEC connector for AC power cable. Connect the supplied heavy-gauge 3-pin IEC power cable.

PROTECTION

Every model in the CV-Series incorporates protection features. The front panel Protection LED indicates the activity of the speaker connection relay circuitry in each channel. When the protection LED turns on, this circuitry is active, and all connected speakers are muted.

Initial power-up : For approximately five seconds after initial power-up, the protection circuitry is activated and the speaker outputs are muted. If everything is operating normally, you will hear an audible click at the conclusion of this brief period, as the protection circuitry is deactivated and the unit begins delivering signal to the connected speakers. It is normal for the Protection LED to fade gradually after the amplifier is powered off.

Thermal Protection : Abnormally high heat sink temperatures will engage the protection circuitry for the overheating channel only. An output relay disconnects the speakers until normal temperature range is restored. The Protect indicator will light to show the protection circuit is active. To guard against this problem, make sure the unit receives adequate ventilation on all sides and that both the front and rear panels are unobstructed. If the power transformer gets too hot, its thermal switch will disconnect all of the secondary power and disconnect both channel outputs.

Short circuit : If output is shorted due to faulty wiring, the thermal circuitry will automatically protect the amplifier. If this occurs, the load will be disconnected by the thermal protection circuitry.

DC Voltage Protection : If an amplifier channel detects DC voltage at the speaker output, the output relay will immediately open to prevent speaker damage.

Subsonic Frequency Protection : The built-in High Pass Filter provides subsonic frequency protection for each channel.

Current limiting Protection : At the amplifier's full power limit, or clipping point, the limiter circuitry will be activated. This is indicated by illumination of the Clip LED. The channel gain is automatically reduced, protecting the speakers from high power. Uncontrolled feedback, oscillations, or improper equipment gain setting may activate this circuitry, which is virtually transparent in operation as full signal bandwidth is maintained.

There is reason to be concerned any time the Protection LED lights up (except for initial power-up during approximately five seconds). If this occurs, turn the amplifier off immediately and check all wiring and external equipment carefully in order to locate and correct the condition.

SETUP

Clip limiter

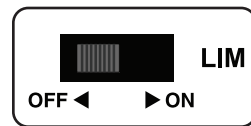

Clipping is the result of an amplifier running into power supply limitation. The maximum output voltage that any amplifier can produce is limited by its power supply. Attempting to output a voltage (or current) level that exceeds the power supply limit will result in a flattening effect on the signal. A clipped waveform exhibits extreme harmonic distortion, making it sound harsh or dissonant. The clip limiter detects this and reduces the gain to minimize the amount of overdrive. To preserve as much of the program dynamics as possible, limiting reduces the average program level until peaks barely clip. Each channel has its own clip limiter, which can be switched on or off. When driving full-range speakers, clip limiting reduces high frequency distortion caused by bass overload. It also protects higher frequency drivers from excess overdrive and harsh clipping harmonics.

HPF (Hi-Pass Filter)

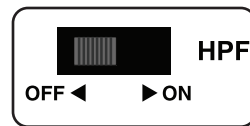

Also known as a low-cut filter, a High Pass Filter rolls off signals below 40Hz. The reproduction of the signal's bass portion is thus optimized, since ultrCV-low, distracting frequencies are eliminated, and more power is available for the reproduction of the wanted segment of the signal.

You should set up the filters so they best suit the frequency response of your speakers, since some speakers are particularly sensitive to over-excursion. The 40Hz filter works well with most compact full-range speakers.

SPEAKER COMPATIBILITY

The CV Series of amplifiers are designed to work with many different speakers on the market. They have been paired with the following Cerwin-Vega speakers. The following compatibility matrix can be used as a reference. (See: www.cerwin-veg.com for product specs.)

Amp Compatibility Information with CV Speakers			
Speakers	Amp Model	Amp Mode	
Two INT-152s	CV-1800	Stereo	
Two INT-252s	CV-1800	Stereo	
Two 118S	CV-2800	Stereo	
Two 118S	CV-2800	Bridged	
Two 118S	CV-1800	Bridged	
One 118S	CV-900	Bridged	
Two INT-152s + Two 118S	CV-2800	Stereo	one top + one sub per amp channel
One JE- or EL-36B	CV-900	Bridged	
Two JE- or EL-36B	CV-2800	Stereo	
Two JE- or EL-36B	CV-1800	Bridged	
One AB-36B	CV-1800	Bridged	
One AB-36B	CV-1800	Bridged	
Two AB-36B	CV-2800	Stereo	
Two INT-252s + Two EL or JE-36B	CV-2800	Stereo	one top + one sub per amp channel
Two INT-252s + Two AB-36B	CV-2800	Stereo	one top + one sub per amp channel
Two INT-152s + Two JE- or EL-36B	CV-2800	Stereo	one top + one sub per amp channel
Two INT-152s + Two AB-36B	CV-2800	Stereo	one top + one sub per amp channel
Two INT-252s + Two 118S	CV-2800	Stereo	one top + one sub per amp channel
Four (2 per ch) INT-252s	CV-1800	Stereo	two INT-252s per channel
Four (2 per ch) INT-152s	CV-2800	Stereo	two INT-152s per channel
Four (2 per ch) INT-152s	CV-1800	Stereo	two INT-152s per channel

SPECIFICATIONS

	CV-900	CV-1800	CV-2800
Output Power	Stereo Both Channel Driven		
8 ohms	210 W	400 W	600 W
4 ohms	320 W	600 W	900 W
2 ohms	420 W	900 W	1400 W
Output Power	Bridged Mono		
8 ohms	650 W	1200 W	1800 W
4 ohms	845 W	1800 W	2800 W
Signal to Noise Ratio (20 Hz ~ 20k Hz)	100dB	102dB	104dB
Distortion (SMPTE-IM)	0.05%	0.01%	0.04%
Input sensitivity @8 ohms	4dBu	4dBu	4dBu
Voltage Gain	30dB	33dB	35dB
Output Circuitry	AB	AB	H
Current Consumption	120Vac (U.S.A) / 240Vac(EU)		
@ 1/8 power @4 ohms	3.3A / 1.7A	8.8A / 4.4A	6.8A / 3.4A
@ 1/3 power @4 ohms	7A / 3.6A	12A / 6A	17A / 8.3A
@ Full power @4 ohms	10.5A / 5.5A	19.5A / 9.5A	32A / 16A
Distortion			
20 Hz-20k Hz Half Power	0.01%	0.01%	0.03%
1k Hz Full Power	0.1%	0.1%	0.1%
Frequency Response	0/-0.5dB ; 20Hz-20KHz, 0/-3dB ; 5Hz-60KHz		
Damping Factor (400 Hz)	200	280	350
Input Impedance	15Kohm Unbalanced, 30Kohm Balanced		
Input Clipping	22dBu (10Vrms)		
Cooling	Continuously variable speed, Front to rear		
Connectors (each)			
Input	Active balanced combo (XLR and 1/4" TRS common use)		
Output	5-way Binding post and Speakon®		
Control			
Front	AC power switch, Channel 1 and 2 volume		
Rear	HPF switch, Limiter switch, Mode selector switch		
Indicators	Active(light blue), Protection(red), Clip(red), Signal (dark blue)		
Protection	Short circuit, Thermal, Current limit, DC offset, Current inrush, RF protection, Turn on / Turn off muting		
Power requirements	100v 50/60Hz(JP) 120V 60Hz(U.S.A. & Canada) 240V 50Hz(EU)		
Dimensions (W _ H _ D)	19"(482mm) _ 3.5"(88mm) _ 16.5"(420 mm)		
Net Weight	28 lb (12.6 kg)	40 lb (18 kg)	46 lb (20.7 kg)

SETUP

Mode Select

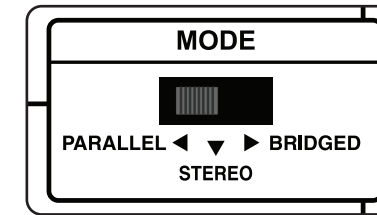

Stereo Mode

In stereo mode, both channels operate independently with individual input gain controls. Signal at channel 1's input produces output at channel 1, while signal at channel 2's input produces output at channel 2's output. Recommended minimum nominal load impedance for stereo operation is 2 ohms per channel.

Parallel Mode

When set to Parallel mode, a signal applied to channel 1's input will be amplified and appear at outputs for both channel 1 & 2. The parallel mode is well suited for applications in which driving two speakers with the same signal but with separate amplification. The 'Channel1' and 'Channel 2' input gain controls individually control the output level on channels 1 and 2.

Bridged Mono Mode

Bridged mono mode straps both amplifier channels together to make a very powerful, single-channel monaural amplifier. One channel "pushes" and the other channel "pulls" equally, doubling the power over that of either channel alone. Therefore the voltage is doubled, the peak power is quadrupled, and program power is roughly three times as high as that of the individual channel.

Signal is applied to the channel 1 input only and channel 1 input gain control is used to adjust signal level. The input gain control belonging to channel 2 are not used.

Note : Bridged mono mode is to be used only when the CV-Series is connected to a 4 or 8 ohms speaker load. Use of Bridged mode with speaker loads of less than 4 ohms can result in severe damage to the unit due to excessive heat and current limiting.

 Use extreme caution when operating the amplifier in Bridged Mono Mode. Never ground either side of the speaker cable; the speaker load must "float" away from the

CONNECTIONS

Stereo Mode

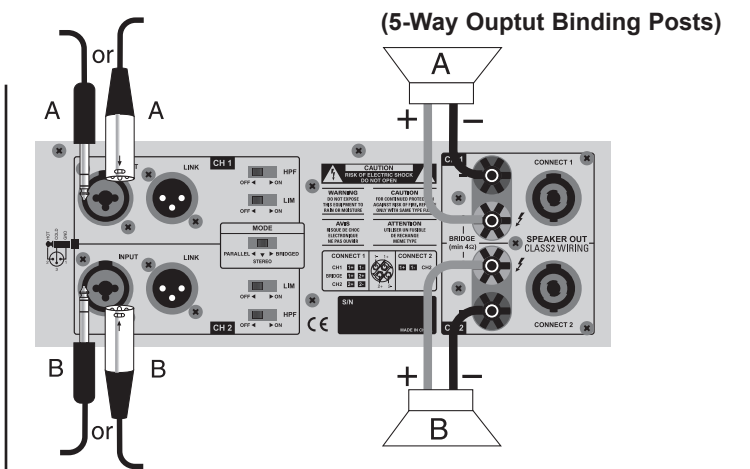

Parallel Mode

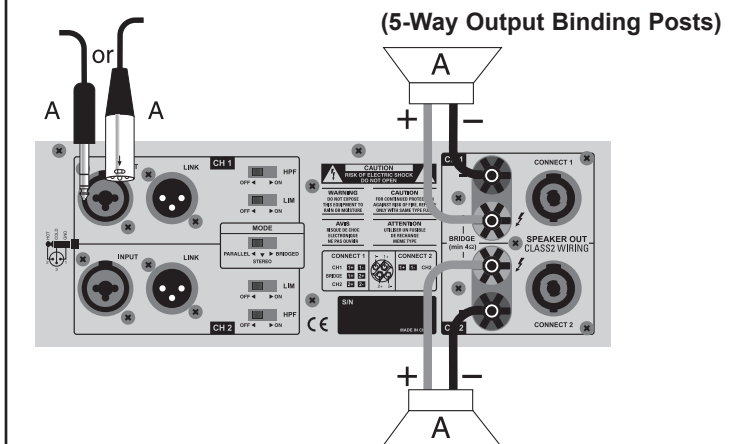

Bridged Mono Mode

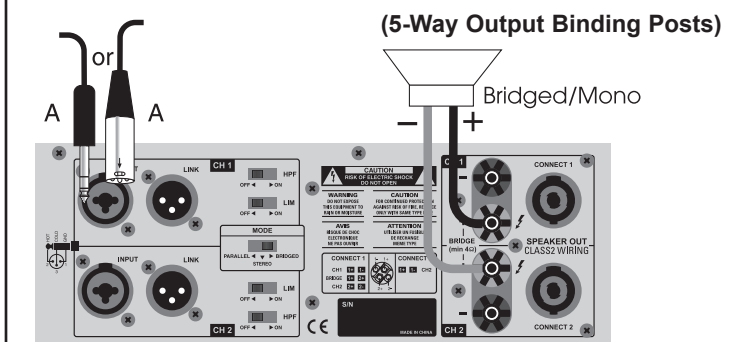

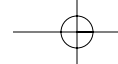

CONNECTIONS

Stereo Mode

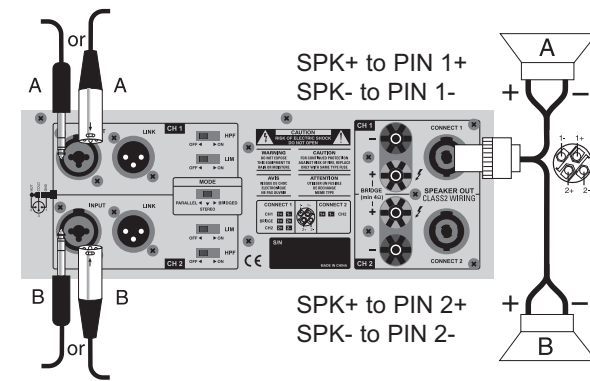
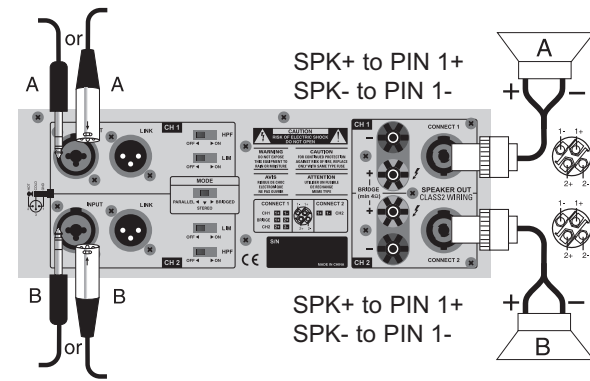

Parallel Mode

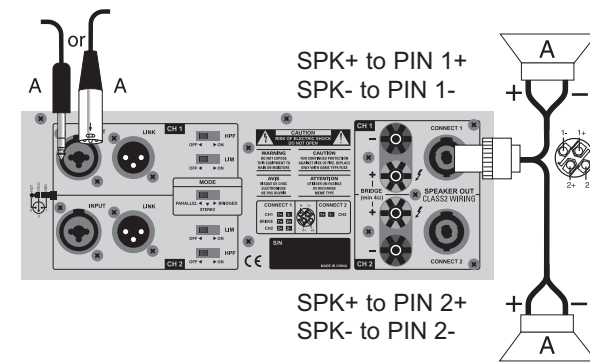
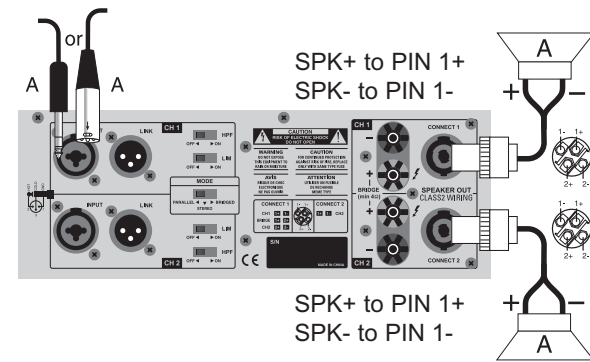

Bridged Mono Mode

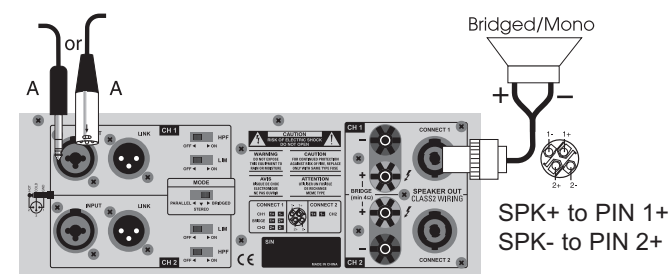

WIRING

These are several ways to interface to the amplifier to support a variety of applications.

Unbalanced 1/4" Connector

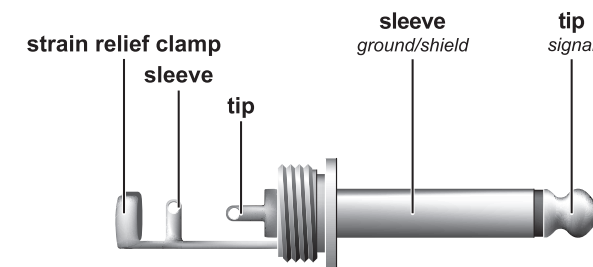

Speakon® Connector

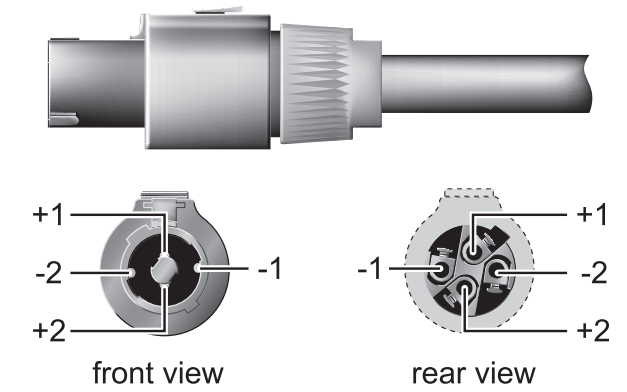

Balanced TRS 1/4" Connector

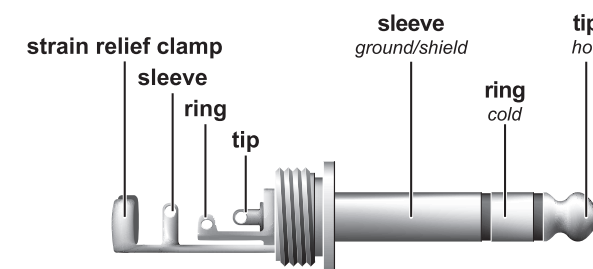

For connection of balanced and unbalanced plugs, ring and sleeve have to be bridged at the stereo plug.

XLR Balanced Wiring Guide

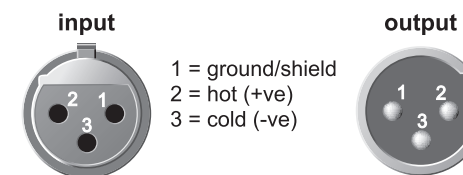

For unbalanced use pin 1 and pin 3 have to be bridged



Free Manuals Download Website

<http://myh66.com>

<http://usermanuals.us>

<http://www.somanuals.com>

<http://www.4manuals.cc>

<http://www.manual-lib.com>

<http://www.404manual.com>

<http://www.luxmanual.com>

<http://aubethermostatmanual.com>

Golf course search by state

<http://golfingnear.com>

Email search by domain

<http://emailbydomain.com>

Auto manuals search

<http://auto.somanuals.com>

TV manuals search

<http://tv.somanuals.com>