

# DC2000 Back-Up Wiring for the OmniControl™ Board with Optional Equipment

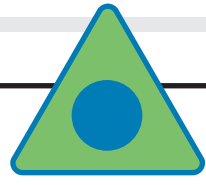

## System Setup

**"Manual" setting:** The DC2000 will respond to the input devices wired to the J 20 socket.

This mode can also be used as an emergency override. If 115 Vac power is on, but the system has an electronic malfunction, the gate can be operated using the DC2000 system with input devices wired to J 20 socket.

**"Auto" setting:** The DC2000 opens the gate automatically upon 115 Vac power failure and stays open. When 115 Vac power is restored, the gate operator will return to normal operation. (The gate can be closed by manual command)

	115 Vac Power Failure	115 Vac Power On, OmniControl Board™ Malfunction	115 Vac Power On, Emergency Override
<b>Manual Mode</b>	Push and <b>Hold</b> to operate gate	Turn the 115 Vac power off then push and <b>Hold</b> to operate gate	Push and <b>Hold</b> to override the OmniControl™ Board
<b>Auto Mode</b>	Gate automatically opens	Turn the 115 Vac power off then gate opens automatically	Push and <b>Hold</b> to override the OmniControl™ Board



## EMERGENCY OVERRIDE

If 115 Vac power is on, but the system has an electronic malfunction, the gate can be operated using the DC2000 system with ANY of these devices shown.

### "Optional Manual One-Button"

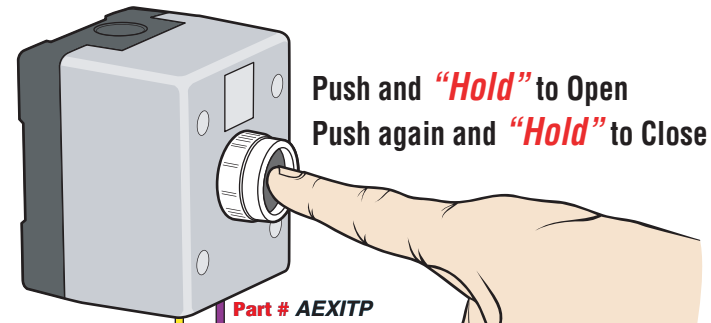

## SAFETY OPTIONS

### "Optional Edge Sensor"

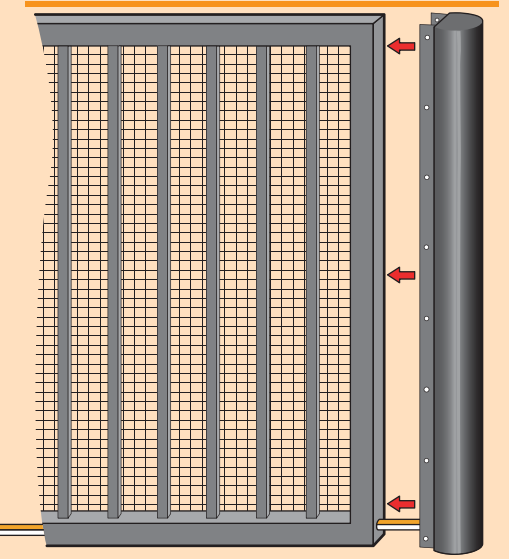

### "Optional Photocell Sensor" 12 VDC

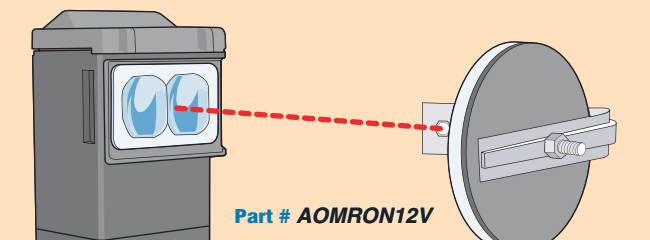

**Failsafe Photocell:** If a photocell is not working or loses power or photo beam is blocked, then the photocell will stop **all** gate operation.

**DO NOT** wire 115 Vac power to the DC2000

If the DC2000 is automatically opening the gate due to a power failure, any manual command such as **"Manual One-Button"**, **"Three Push Button"**, **"Key Switch"**, **"Photocell"** or **"Edge Sensor"** will cancel the automatic mode of the DC2000. After such cancellation, the DC2000 will continue to operate in manual mode until 115 Vac power is restored.

**J 20 Socket**

### "Optional Key Switch"

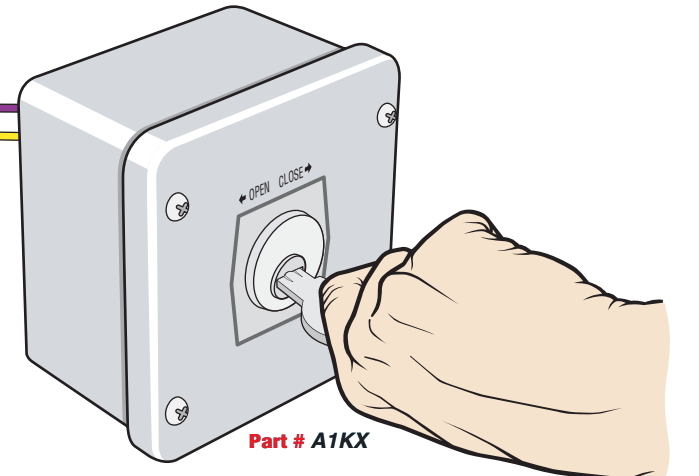

**Interlock Assembly**

### "Optional Three-Button"

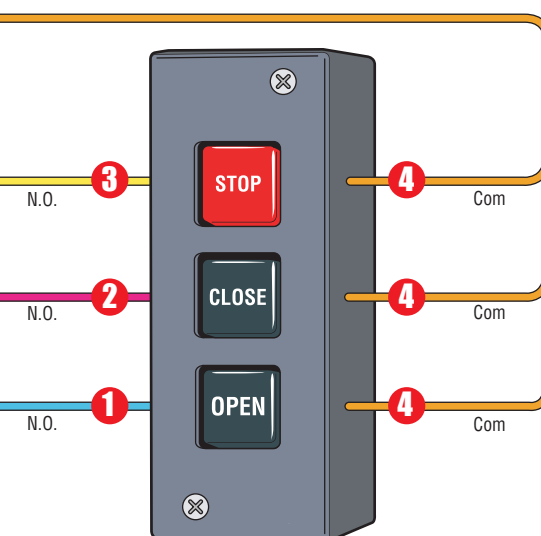

### "Optional Radio Receivers"

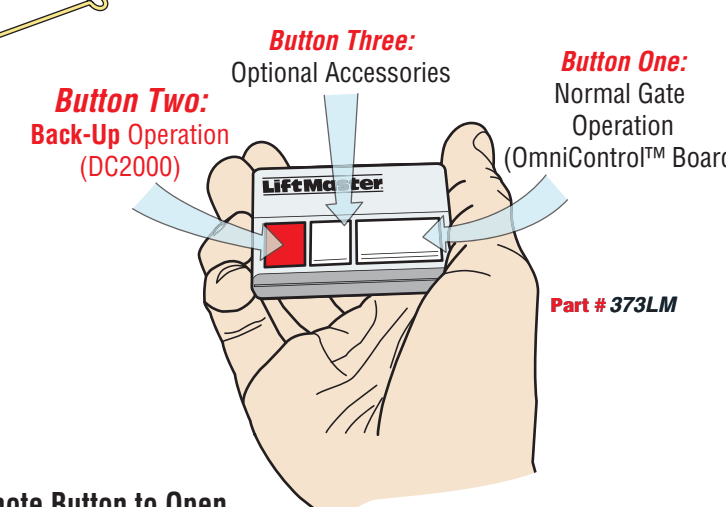
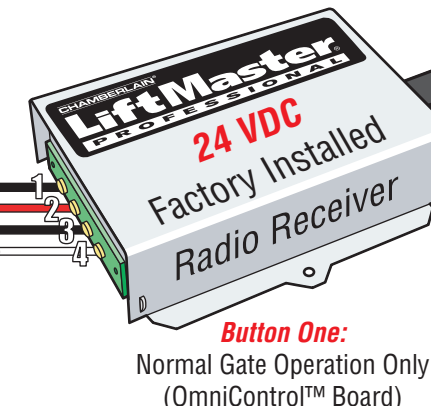
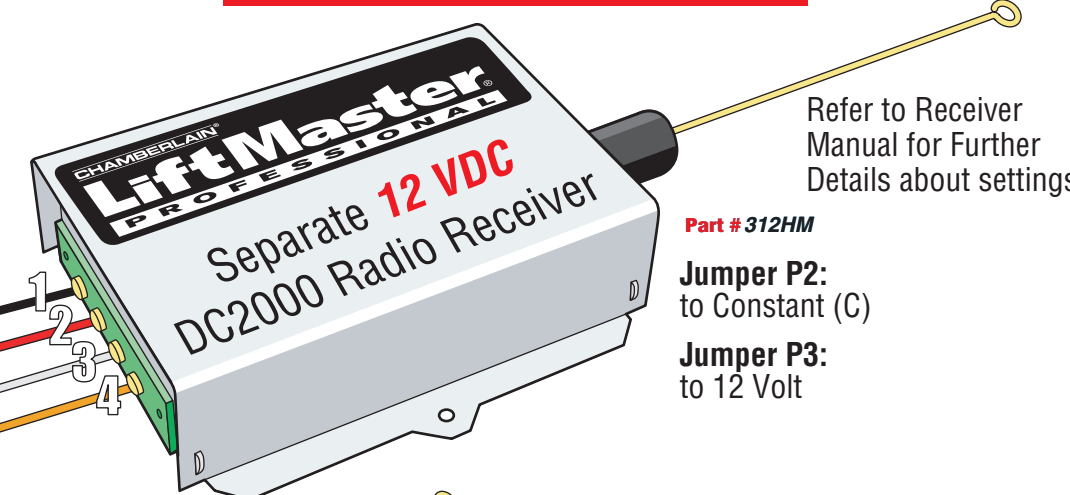

Push and **"Hold"** DC2000 Remote Button to Open  
Push again and **"Hold"** DC2000 Remote Button to Close

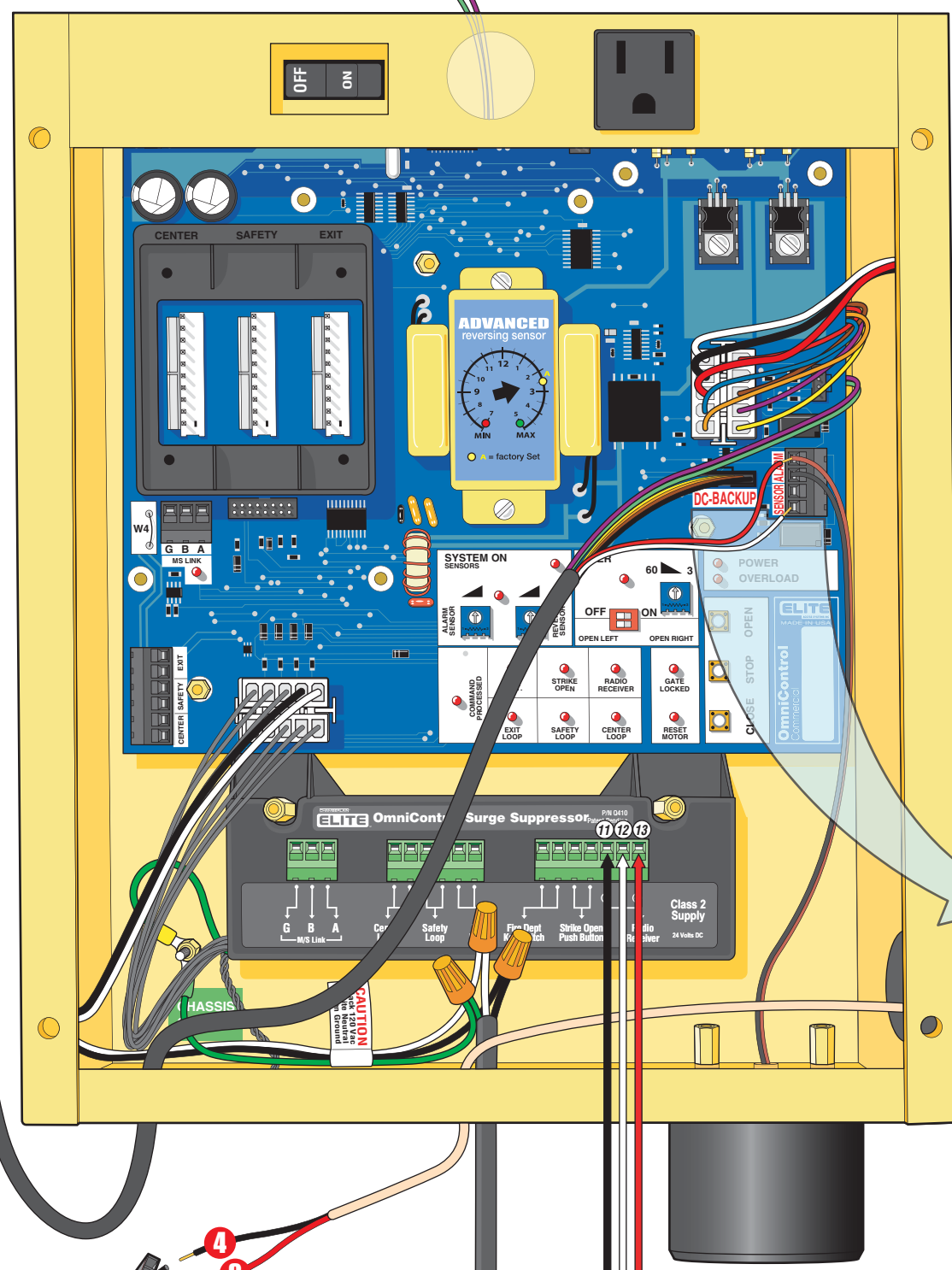

**DO NOT** remove existing wires from the audio alarm or secondary protection sensor.

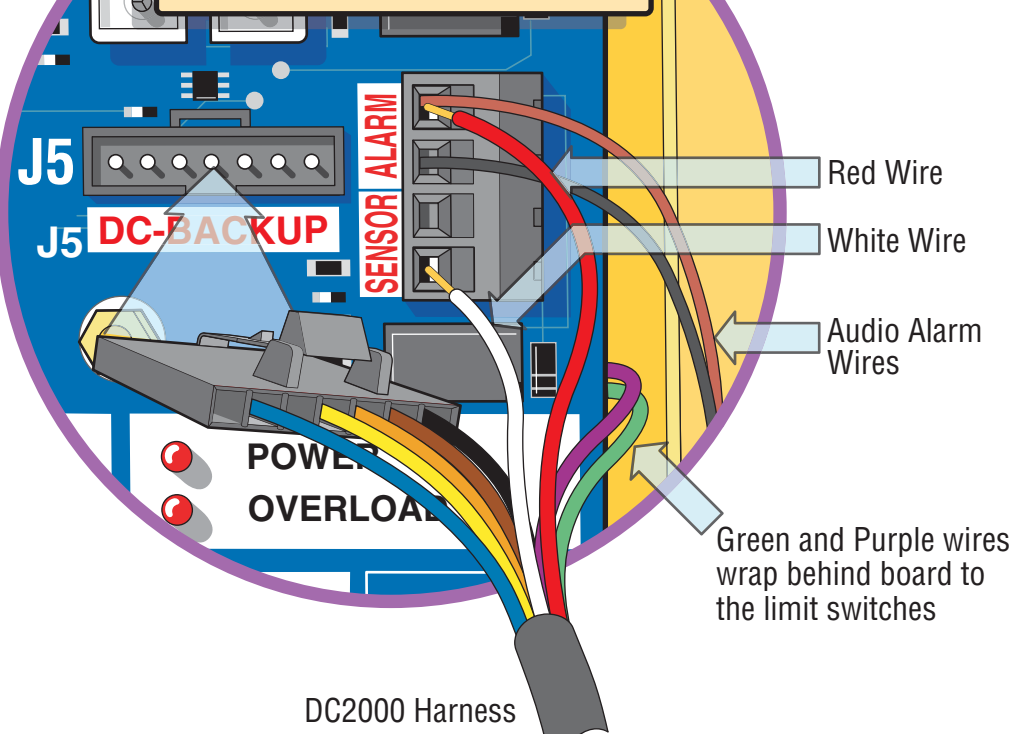

Cut and Discard Plug

Factory installed Interlock Assembly Wires to J20 Socket

For Technical Support and Ordering Parts:  
**1-800-528-2806**



# DC2000 Back-Up Installation for SL3000UL™ models

## SL3000UL™ & SL3000ULD™ Step-by-Step DC2000 Installation

### STEP 1

Bolt the DC2000 plate and guard to the operator chassis. Do not tighten the bolts. Adjustment is required in Step 3.

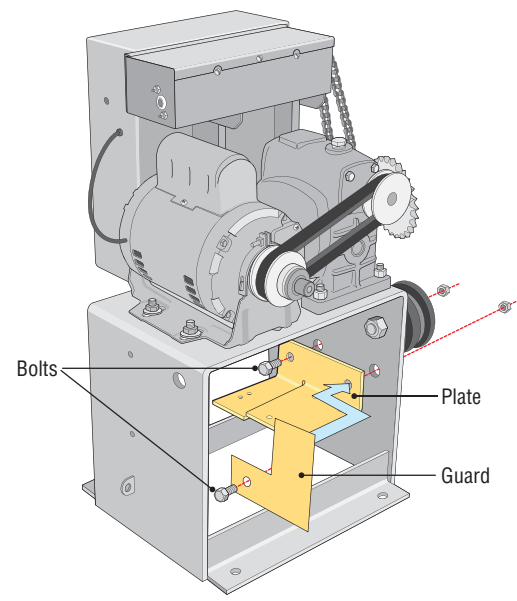

### STEP 2

- A Bolt the DC2000 control unit to the plate.
- B Bolt the DC motor to the plate.
- C Connect the DC motor wires to the DC2000 control unit wires. **Red to Red and Black to Black.**

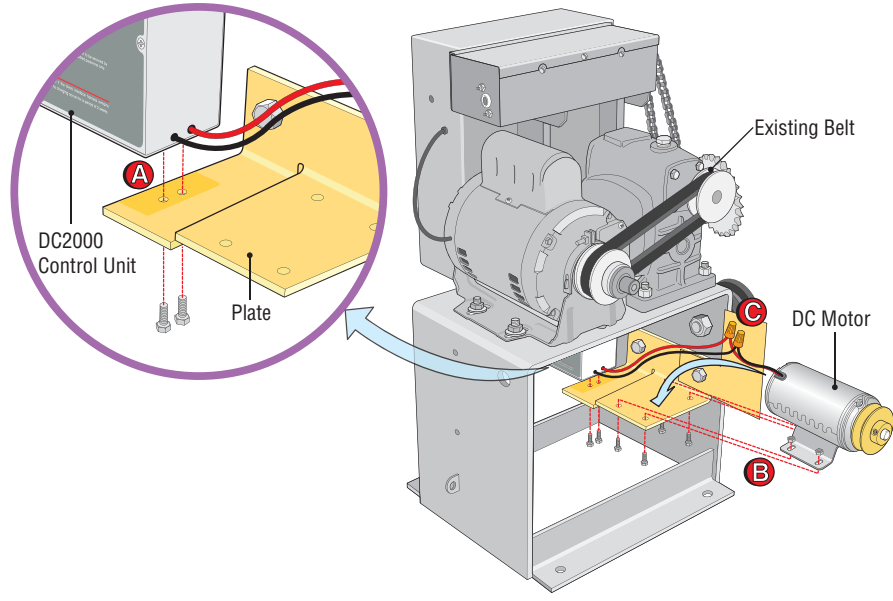

### STEP 3

- A Replace the existing belt with the new belt provided. Make sure that the pulleys are aligned.
- B Pull down the DC2000 Plate to tighten the belt tension. Tighten the plate bolts to secure the plate.

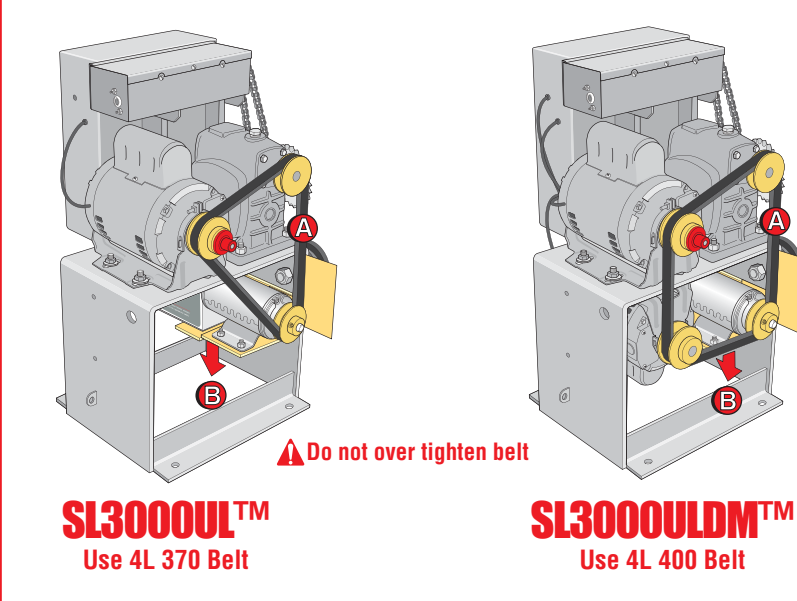

### STEP 4

- A Remove the OmniControl™ board from the electrical box.
- B Plug in the DC2000 harness into the DC2000 control unit.
- C Feed the DC2000 harness through the bottom of the electrical box.
- D Feed the green and purple wires to the limit box.

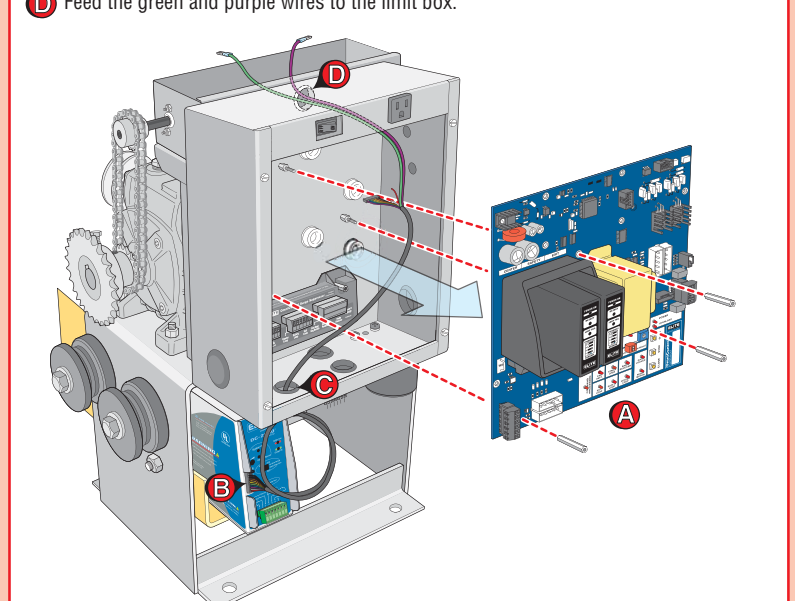

### STEP 5

- A Reinstall the OmniControl™ board and make sure that the green and purple wires do not get pinched by the board.
- B Plug in the DC2000 harness in the DC-BackUp J5 slot on the OmniControl™ board.
- C Connect the red wire from the DC2000 harness into the top slot of the audio alarm plug. **(DO NOT remove audio alarm wires)**
- D Connect the white wire from the DC2000 harness into the bottom slot of the sensor plug.

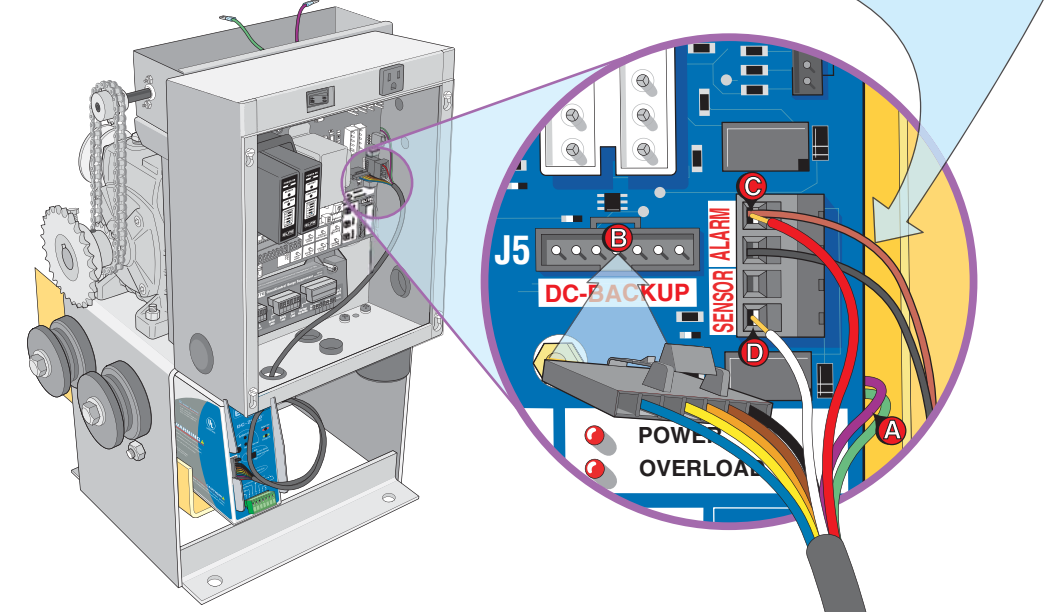

### STEP 6

- A Connect the purple and green wires to the limit switches.
- B Make sure brown wire is in the "Common" connector on the limit switch. ⚠

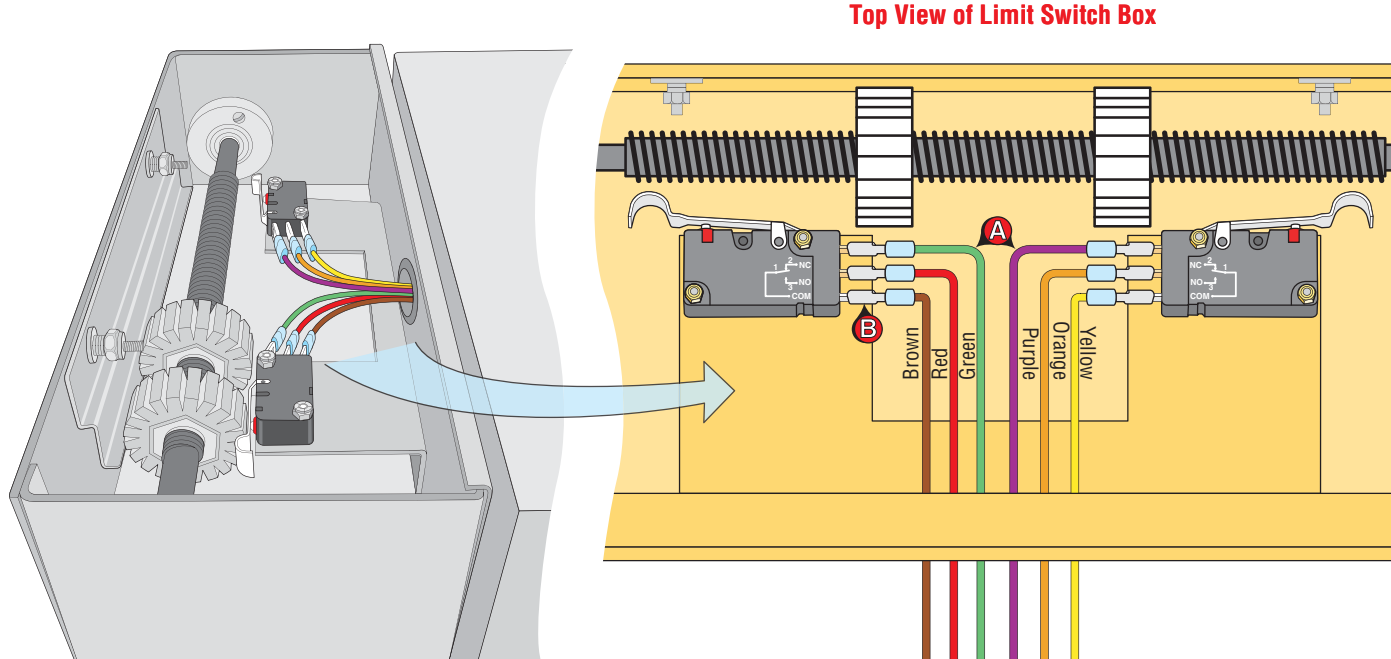

### STEP 7

- A Set switch for the gate direction. (Open left or Open right)
- B Select your mode of operation for the DC2000 unit. (Automatic open or Manual open)
- C Permanently wire optional controls according to label on control unit. (See back page)
- D Adjust the sensitivity for the reverse sensor.



## SL3000UL™ & SL3000ULD™ with Interlock Assembly Step-by-Step DC2000 Installation

### STEP 1

Bolt the DC2000 plate and guard to the operator chassis. Do not tighten the bolts. Adjustment is required in Step 3.

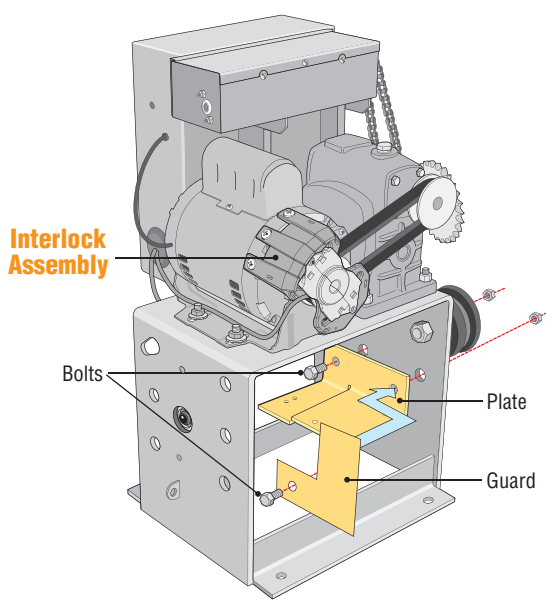

### STEP 2

- A Bolt the DC2000 control unit to the plate.
- B Bolt the DC motor to the plate.
- C Connect the DC motor wires to the DC2000 control unit wires. **Red to Red and Black to Black.**

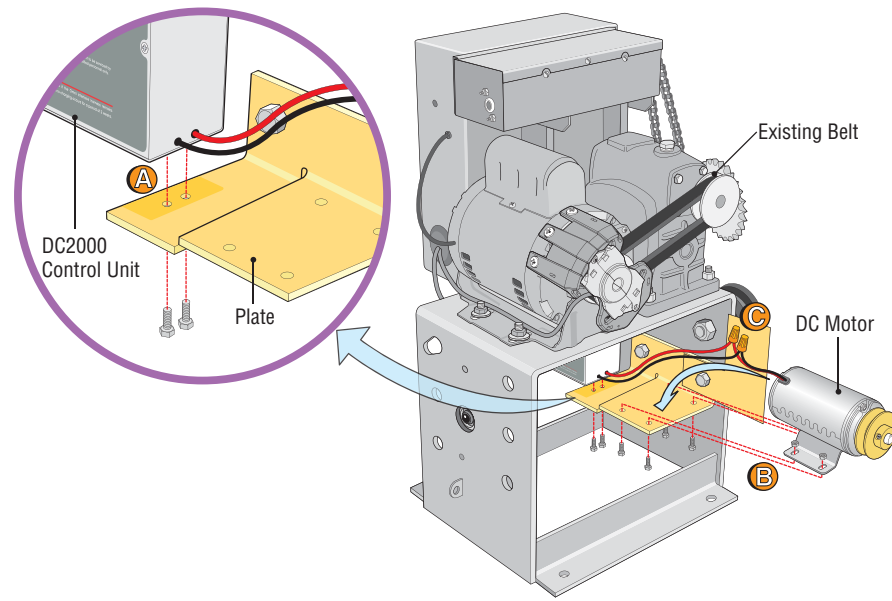

### STEP 3

- A Remove interlock assembly from motor with 3 screws.
- B Replace the existing belt with the new belt provided. Make sure that the pulleys are aligned.
- C Pull down the DC2000 Plate to tighten the belt tension. Tighten the plate bolts to secure the plate.
- D Reattach interlock assembly.

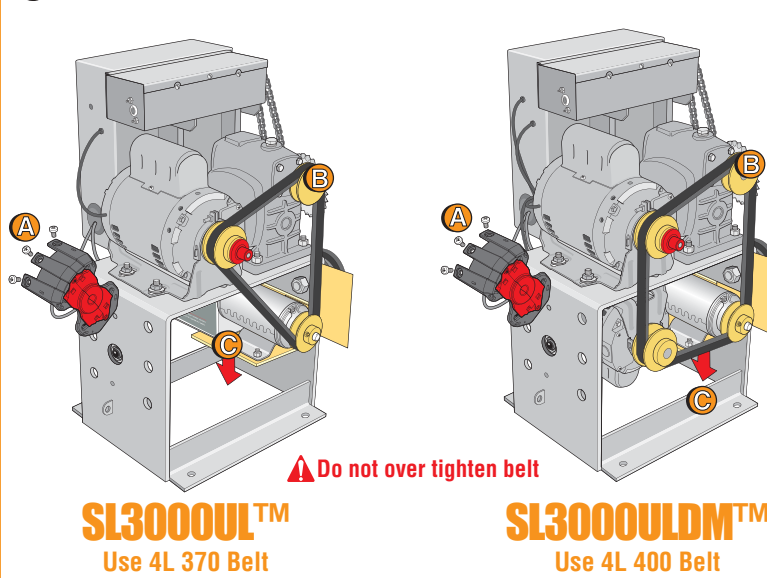

### STEP 4

Unplug interlock wire from OmniControl board, cut the plug off and strip wires. Insert **Red** wire in J-20 socket 3 and **Black** wire into socket 4 of the DC2000.

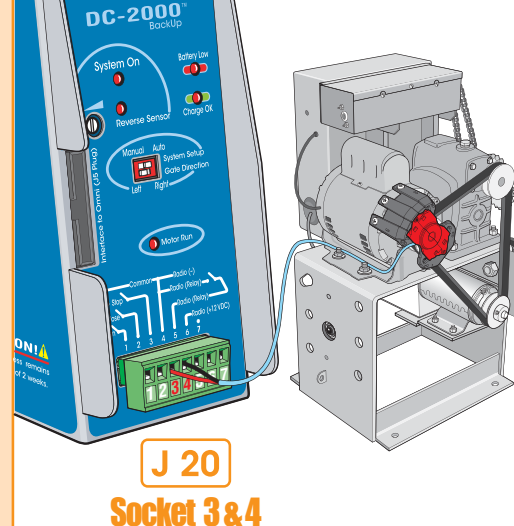

### STEP 5

- A Remove the OmniControl™ board from the electrical box.
- B Plug in the DC2000 harness into the DC2000 control unit.
- C Feed the DC2000 harness through the bottom of the electrical box.
- D Feed the green and purple wires to the limit box.

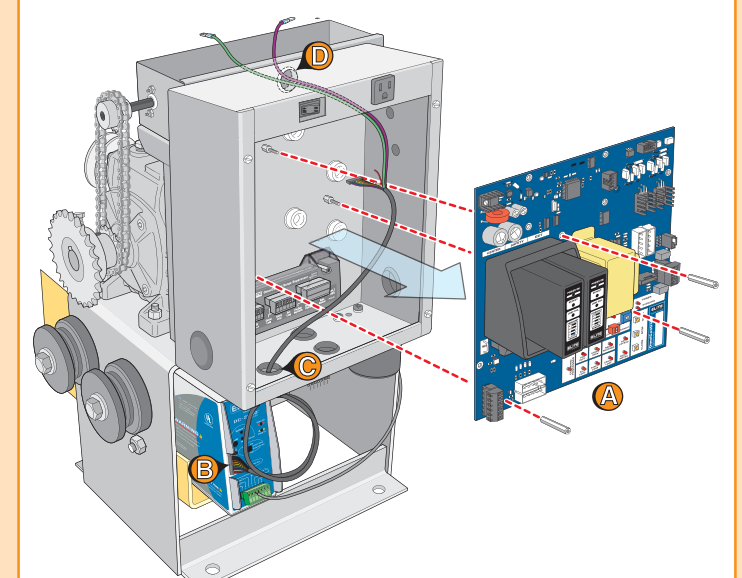

### STEP 6

- A Reinstall the OmniControl™ board and make sure that the green and purple wires do not get pinched by the board.
- B Plug in the DC2000 harness in the DC-BackUp J5 slot on the OmniControl™ board.
- C Connect the red wire from the DC2000 harness into the top slot of the audio alarm plug. **(DO NOT remove audio alarm wires)**
- D Connect the white wire from the DC2000 harness into the bottom slot of the sensor plug.

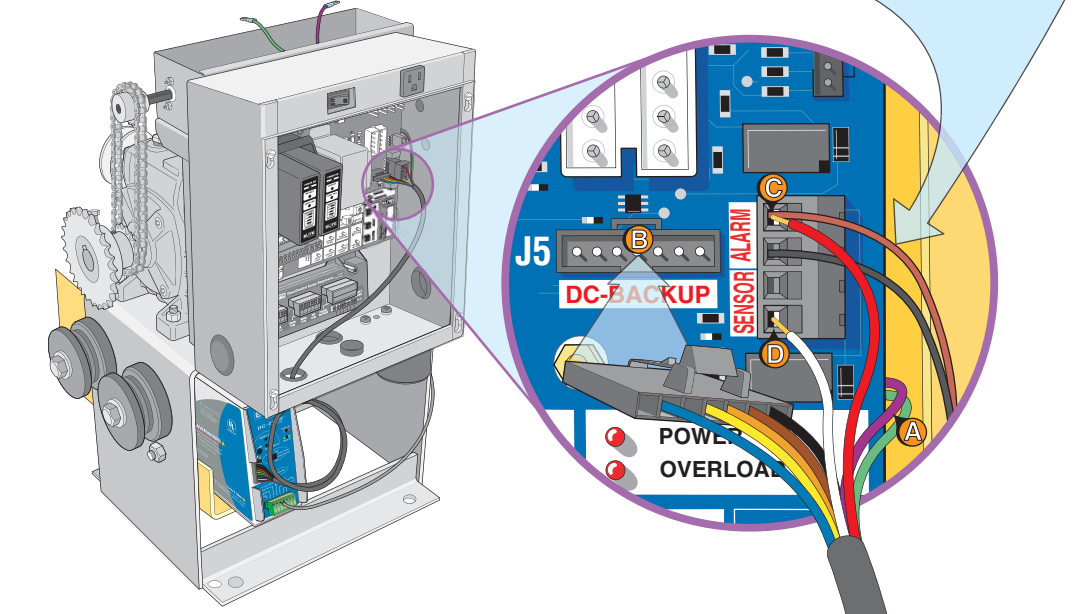

### STEP 7

- A Connect the purple and green wires to the limit switches.
- B Make sure brown wire is in the "Common" connector on the limit switch. ⚠

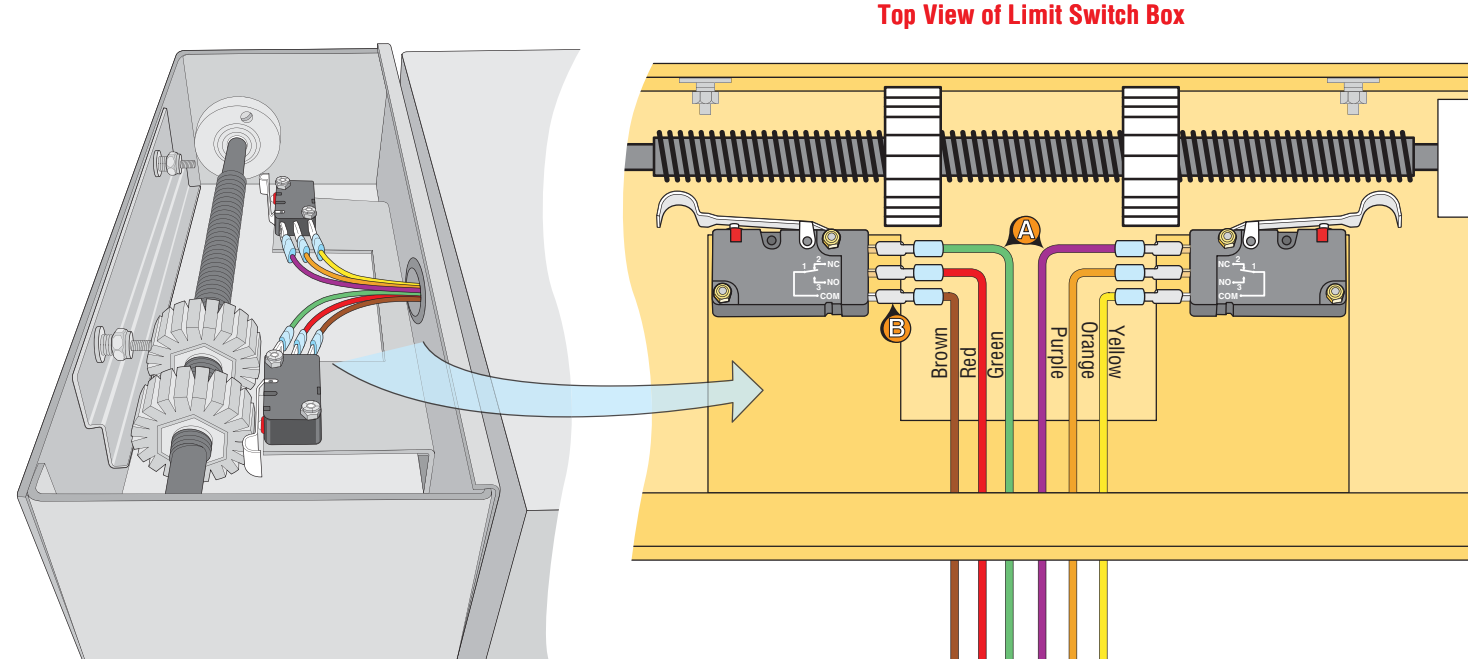

### STEP 8

- A Set switch for the gate direction. (Open left or Open right)
- B Select your mode of operation for the DC2000 unit. (Automatic open or Manual open)
- C Permanently wire optional controls according to label on control unit. (See back page)
- D Adjust the sensitivity for the reverse sensor.



For Technical Support and Ordering Parts:  
**1-800-528-2806**

© 2008 The Chamberlain Group, Inc.  
All Rights Reserved.

CHAMBERLAIN®  
**ELITE™**  
845 Larch Avenue, Elmhurst, Illinois 60126  
www.chamberlain.com



## Free Manuals Download Website

<http://myh66.com>

<http://usermanuals.us>

<http://www.somanuals.com>

<http://www.4manuals.cc>

<http://www.manual-lib.com>

<http://www.404manual.com>

<http://www.luxmanual.com>

<http://aubethermostatmanual.com>

Golf course search by state

<http://golfingnear.com>

Email search by domain

<http://emailbydomain.com>

Auto manuals search

<http://auto.somanuals.com>

TV manuals search

<http://tv.somanuals.com>