

**CITIZEN**

**User's Manual**

Model      CBM-290/291

**Japan CBM Corporation**  
Information Systems Div.

### <Important safety instruction>

- Read all of these instructions and save them for later reference.
- Follow all warnings and instructions marked on the product.
- Unplug this product from the wall outlet before cleaning. Do not use liquid or aerosol cleaners. Use a damp cloth for cleaning.
- Do not use this product near water.
- Do not place this product on an unstable cart, stand or table. The product may fall, causing serious damage to the product.
- Slots and openings on the cabinet and the back or bottom are provided for ventilation. To ensure reliable operation of the product and to protect it from overheating, do not block or cover these openings. The openings should never be blocked by placing the product on a bed, sofa, rug or other similar surface.  
This product should never be placed near or over a radiator or heat register.  
This product should not be placed in a built-in installation unless proper ventilation is provided.
- This product should be operated from the type of power source indicated on the marking label. If you're not sure of the type of power available, consult your dealer or local power company.
- Do not allow anything to rest on the power cord. Do not locate this product where the cord will be walked on.
- In an extension cord is used with this product, make sure that the total of the ampere ratings on the products plugged into the extension cord do not exceed the extension cord ampere rating. Also, make sure that the total of all products plugged into the wall outlet does not exceed 15 amperes.
- Never push objects of any kind into this product through cabinet slots as they may touch dangerous voltage points or short out parts that could result in a risk of fire or electric shock. Never spill liquid of any kind on the product.
- Except as explained elsewhere in this manual, don't attempt to service this product yourself. Opening and removing those covers that are marked "Do Not Remove" may expose you to dangerous voltage points or other risks. Refer all servicing on those compartments to service personnel.
- Unplug this product from the wall outlet and refer servicing to qualified service personnel under the following conditions:
  - A. When the power cord or plug is damaged or frayed
  - B. If liquid has been spilled into the product.
  - C. If the product has been exposed to rain or water.
  - D. If the product does not operate normally when the operating instructions are followed. Adjust only those controls that are covered by the operating instructions since improper adjustment of other controls may result in damage and will often require extensive work by a qualified technician to restore the product to normal operation.
  - E. If the product has been dropped the cabinet has been damaged.
  - F. If the product exhibits a distinct change in performance, indicating a need for service.
- Please keep the poly bag which this equipment is packed in away from children or throw it away to prevent children from putting it on. Putting on it may cause suffocation to them.

**IMPORTANT:** This equipment generates, uses, and can radiate radio frequency energy and if not installed and used in accordance with the instruction manual, may cause interference to radio communications. It has been tested and found to comply with the limits for a Class A computing device pursuant to Subpart J of Part 15 of FCC Rules, which are designed to provide reasonable protection against such interference when operated in a commercial environment. Operation of this equipment in a residential area is likely to cause interference, in which case the user at his own expense will be required to take whatever measures may be necessary to correct the interference.

**CAUTION:** Use shielded cable for this equipment.

For Uses in Canada

This digital apparatus does not exceed the class A limits for radio noise emissions from digital, apparatus, as set out in the radio interface regulations of the Canadian department of communications.

## <Cautions>

1. Before using this equipment, be sure to read this User's manual thoroughly and save it for future reference.
2. Portions of the contents of this User's manual may be changed without prior notice.
3. The reproduction of parts or all of the contents of this User's manual without permission is strictly forbidden.
4. Absolutely do not carry out maintenance, disassembly, or repair of parts that are not specified in this User's manual.
5. Note that losses which may be attributed to the user's wrong operation method or operating environment will be outside the responsibility of this company.
6. Do not carry out operations other than those explained in this User's manual, since doing so may cause an accident or breakdown.
7. Because data is basically transient, long-period and permanent storage of data will not be possible. Please note in advance that this company will not be responsible in any way for losses or lost profits caused through the clearing of the data due to breakdowns, repairs, investigations, etc.
8. If any questionable points, mistakes, omitted explanations, etc. are found in the contents of this manual, please contact this company.
9. Please note that notwithstanding the conditions in above 8, this company will not be responsible for the consequences of results obtained through operation of this equipment.
10. Please make sure to carry out maintenance before using this equipment after long term storage.



This symbol represents an illustration shown to attract user's attentions.



This symbol represents an illustration shown the information like method etc....

## <! Warning>

Do not subject this equipment to excessive force or shocks such as by standing on it, dropping it or hitting it.

Do not install this equipment in locations with poor ventilation, and do not use the equipment in such way that the ventilation port is obstructed.

Do not use this equipment in locations such as laboratories in which chemical reaction takes place, or in locations in which the air includes salt or toxic gases.

Do not use this equipment at voltage other than the specified voltage or at frequencies other than at the specified frequencies.

Do not insert or remove the power cables or interface cable by pulling on the cable, and do not carry the main unit in such way as to subject the cables to force.

Do not drop or insert foreign subjects like paper clips or split pins, etc. into the equipment.  
In case of dropping those foreign object into the equipment, remove power supply plug and contact your sales shop.

Do not arrange the power cable so that many plugs are using same power outlet.

Do not spill drinks such as tea, coffee or juice, or spray any chemicals liquid, etc onto the equipment.  
In case of spilling drinks like water, switch off the power, remove power supply cable and contact your sales shop.

Do not attempt to disassemble or modify this equipment, since these actions will cause fire or electric shock.

Please keep the poly bag which this equipment is packed in away from children or throw it away to avoid children putting it on, putting it on may cause suffocation.

## <! Precautions for installation>

1. Do not install or store this printer near fire, water, a heater, in the direct sunshine in the locations such as high-temperature, high humidity, oily and dusty. This may cause fire and abnormality.
2. Do not use this printer in locations such as laboratories in which chemical reactions take place, or in locations in which the air includes salt or toxic gases. This may cause a fire or electric shock.
3. Make sure to install this printer on the vertical mounting panel with no vibration.
4. Do not use this printer in the locations which have environment to cause trouble in operations.
5. Do not put anything on the printer unit. This may cause a breakage.
6. To fix this printer, make sure to use enclosed rack mounting bracket and screws. Do not fasten the screws excessively. This may cause abnormality and breakage.
7. Do not use this printer near radio or television, and do not use same outlet as the one used for radio and television. This may cause a trouble with receiving an electric wave.
8. Do not use voltage or power supply other than specified in this manual. Do not use this printer in case + side and GND are not connected properly. This may cause breakage and a fire.
9. Make sure that capacity of the power supply connected to this printer is enough before using this printer.
10. Do not arrange the power cable so that many plugs are using same power outlet.  
This may cause heat or fire of power supply cable due to the excess of capacity and power supply may be cut off.  
Do not tread on the power supply cable or do not put anything on this cable.
11. Absolutely do not connect the earth with gas pipe. This may a possibility of explosion.  
Make sure to remove the power plug from power outlet in case of connect or disconnect the earth.
12. Make sure to connect or disconnect the cable holding the main body of connectors after switching off the both power of this equipment and the equipment which this equipment is connected to.
13. Certainly connect the connector cables. Especially, if the polarity is connected in reverse way, this may cause the damage to the internal parts or to the equipment which this equipment is connected to.
14. To avoid data transmission error due to noise, make sure not to use too many extension power supply cables , or not to connect the other equipment creates much noise with this single line.

! Caution label is attached on the following position.  
Make sure to use this equipment properly. Read the cautions for handling carefully.

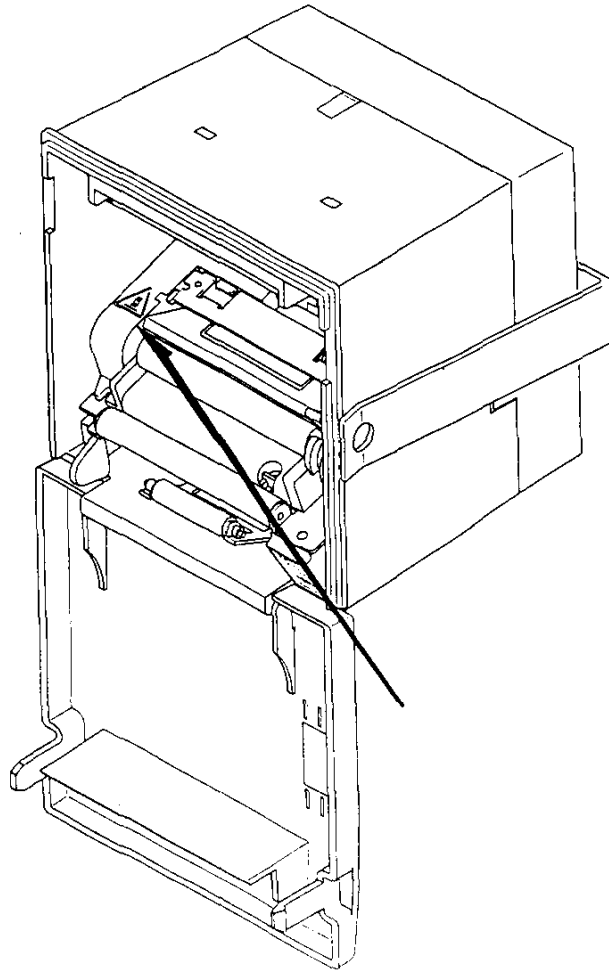

This label indicates the danger of burn due to the heat of print head.

### < ! Ordinary Maintenance >

1. Make sure to maintain the equipment after switching OFF the power .
2. When cleaning the platen of printer mechanism, wipe out the dirty portion by a cotton pad dipped into ethyl alcohol.
3. When cleaning the surface of the main unit case, use soft cloth.  
In case the dirty portion can not be cleared out by the soft cloth, use wet cloth squeezed tightly.  
Absolutely do not use thinners, trichlene, benzine or ketone group solvents, or chemical-impregnated cleaning cloths.
4. In case the print head becomes dirty because of paper dust, clean it by using a soft brush.

! Cautions : Do not carry out the maintenance right after printing, since print head and motor are so hot.



# Contents

1 Outline .....	11
1.1 Features .....	11
1.2 Package.....	11
2 Basic Specifications.....	12
2.1 Model classifications .....	12
2.2. Specifications .....	13
2.3. Specifications of Roll paper.....	14
2.3.1. Recommended paper .....	14
2.3.2. Printing position .....	14
2.3.3. Position of printer head and auto cutter .....	14
2.4 Specified Power Supply.....	15
2.5 Outer appearances and parts name.....	15
2.5.1 Outer appearances and parts name .....	15
2.5.2 Explanation of each parts .....	16
3 Operation .....	17
3.1 Rack mounting .....	17
3.2 Connecting a cable for power supply and interface.....	18
3.3 Opening/closing front cover.....	19
3.4 Paper feeding.....	19
3.5 Auto paper loading function .....	20
3.6 Setting roll paper.....	20
3.7 Removing paper jam and canceling cutter lock .....	21
3.8 Self print function .....	21
3.9 PE and Mechanical alarm.....	21
4. Dip switch setting .....	23
5. Connecting connector .....	24
5.1 Function of each connector pins .....	24
5.2 Precautions .....	25
6 Parallel Interface .....	25
6.1 Specifications .....	25
6.2 Explanation of input / output signals .....	25
6.3 Electrical characteristics .....	26
6.4 Timing chart.....	27
6.5 Data receiving control.....	27
6.6 Buffering .....	27
7 Serial Interface.....	28
7.1 Specifications.....	28
7.2 Explanation of Input / Output signals .....	29

7.3 Date configuration.....	30
7.4 Error detection.....	30
7.5 Data receiving control.....	31
7.6 Buffering .....	31
7.7 Electrical characteristics .....	31
8. Print Control Function .....	32
8.1 Command Lit.....	32
8.2 Command Details.....	33
9. Character Table.....	46
9.1 International .....	46
9.2 International Character Code Table .....	47
Appendix 1. Block Diagram .....	48
Appendix 2. Outer Appearance .....	49

## 1 Outline

CBM-290 is a Line Thermal printer which can be equipped in a rack and is widely used for various data communication, POS terminal and various measurement devices.

This printer can be used for various applications since abundant functions are incorporated.

Prior to actual use, please read this instruction manual carefully for your correct understanding.

### 1.1 Features

- 1 Ultra small-sized rack mounting line thermal printer
- 2 High speed and quite printing
- 3 High reliability due to the long life of thermal print head and simple design
- 4 Serial(RS-232C) and Parallel(Centronics) interface are available by dip switch
- 5 Input buffer incorporated
- 6 Bar code printing(by special command)
- 7 Auto paper cutter is equipped(CBM-291 only)
- 8 User-defined character registration function (94 characters)

### 1.2 Package

Make sure to confirm the following components are contained in this package.

Printer main unit	1 pc
Roll paper sample	1 pc
A cable for power supply and interface	1 pc
Rack mounting bracket	1 pc
Screw for mounting	2 pcs
Wire cramp	1 pc
User's manual	1 pc

## 2 Basic Specifications

### 2.1 Model classifications

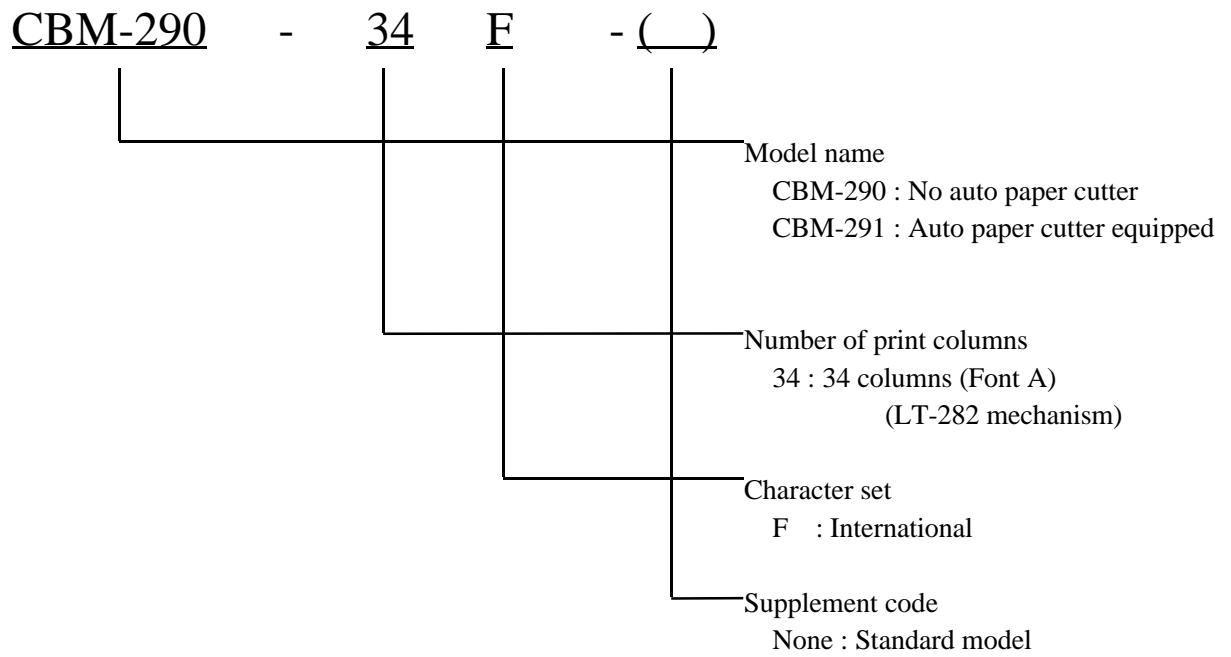

## 2.2. Specifications

ITEM	CONTENTS
Printing method	Line Thermal Dot Printing System
Print speed	50 mm / s (MAX)
Dot density	8 Dots / mm (Vertical / Horizontal)
Number of columns	Font A : 34 columns Font B : 46 columns
Character size	Font A : 1.25 mm x 3.00 mm (10 x 24 + 2 dot space) Font B : 0.88 mm x 2.13 mm ( 7 x 17 +2 dot space)
Character type	Alphanumeric, international characters
Bar code type	UPC-A/E, JAN (EAN) 13 / 8 columns , ITF CODE 39, CODE 128, CODABAR
Line pitch	4.23 mm (1/6 inch) (Selectable by command)
Paper	Thermal Roll Paper Paper Width : 58 mm Roll Diameter : Ø50 mm or less
Interface	Parallel (conforms to Centronics) or Serial (conforms to RS-232C) (Selectable by dip switch)
Input buffer	4 K bytes
Paper end detection	Equipped (Printer stops printing when roll paper runs out completely.)
Auto-Loading function	Equipped (Printer automatically feeds paper when paper sensor detects paper in paper inlet.)
International Character	U.S.A., France, Germany, U.K., Denmark 1,2, Sweden, Italy, Spain, Japan, Norway (Specified by command)
Auto paper cutter (Only CBM-291)	Printer automatically cuts paper by command. Partial cut (One tear point left) and Full cut are available by command.
Supply voltage	5V ± 5 % Stand-by : Approx.0.2A Printing : Approx. 0.2A 24 V ± 5 % Stand-by : Approx. 10mA Printing : Average : 1.8 A (Peak approx. 6 A)
Operating environment	5 - 40°C 35 - 85 % RH (No condensation)
Storage environment	-20 - 60 °C 10 - 90 % RH (No condensation)
Outer dimension	106 mm (W) x 109 mm(H) x 99 mm(D)
Weight	Approx. 560 g (Main body)
Safety standard	UL, CUL, TUV
EMI	FCC : Class A , VCC I: Class A (These standards are applied only for the printer which is used with our exclusive AC Adapter.)
Reliability	Print head life : Pulse resistance 50 million pulse (printing ratio 12.5%) Wear resistance 30 km (at normal temperature and humidity, with recommended paper) Auto cutter life : 300,000 cuts (CBM-291)

## 2.3. Specifications of Roll paper

### 2.3.1. Recommended paper

Type	: Thermal Paper
Paper width	: 58 + 0, - 1 mm
Paper thickness	: 65 ± 5 micro m
Outer diameter	: Ø50 mm or less
Recording side	: Outside of roll
Recommended type	: Japan Paper Mill TF50KS-E2C or equivalent
Core	: Ø12 mm (Inner diameter), 18 mm (Outer diameter)

#### ! Cautions :

1. Do not paste the paper to the core.
2. Chemicals or oil may change the color of paper, or printed characters may fade.
3. Change of paper color starts from approx. 70°C. Pay attention to heat, humidity and sun light.
4. Color of paper may be changed by being scratched by nail or hard metal, etc.

### 2.3.2. Printing position

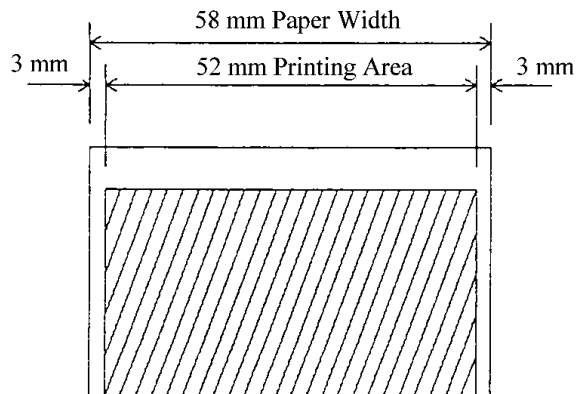

### 2.3.3. Position of printer head and auto cutter

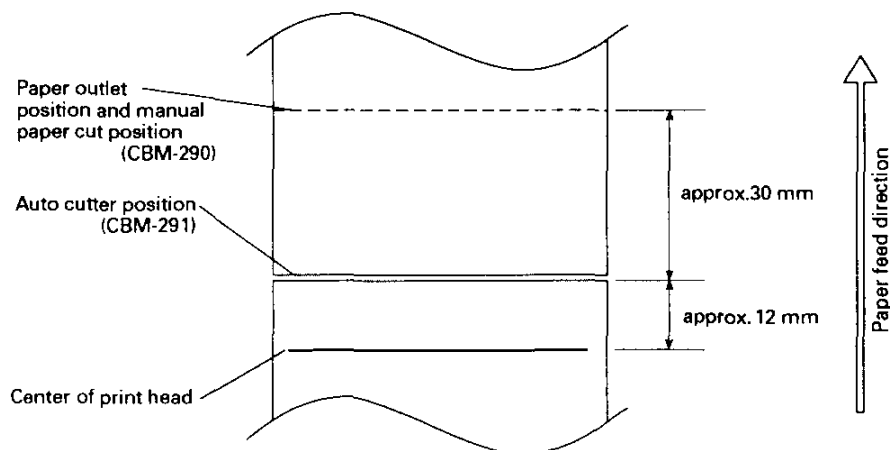

## 2.4 Specified Power Supply

The following specifications is required for Power supply.

VCC : DC 5V  $\pm$  5% 0.2 - 0.5 A

VP : DC24V $\pm$ 5% 2 - 3 A (6A or more at peak)

Avoid using power supply which its power capacity of power current is extremely high.

## 2.5 Outer appearances and parts name

### 2.5.1 Outer appearances and parts name

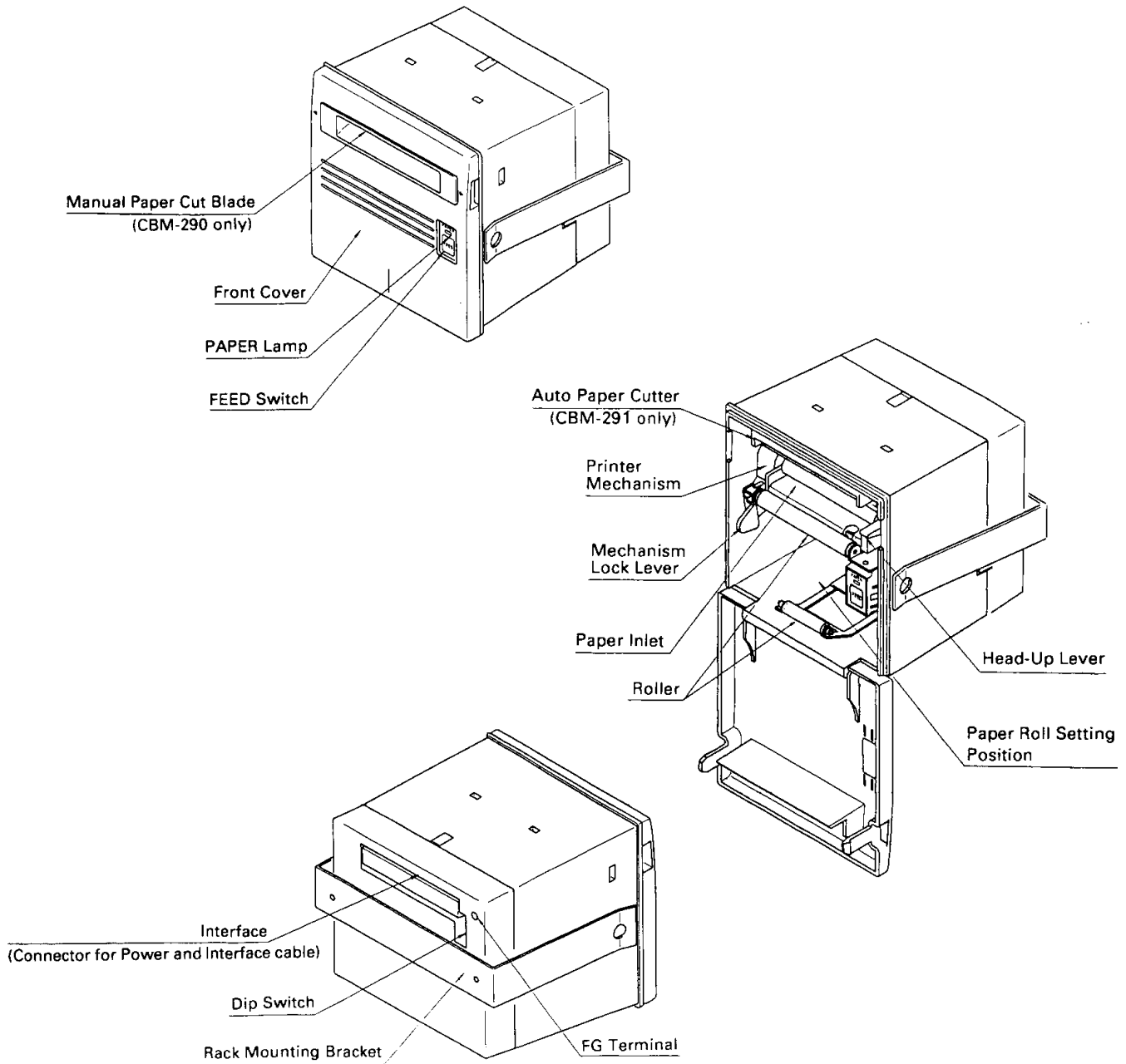

### 2.5.2 Explanation of each parts

- Front cover  
Open/close this cover in case of paper change or paper jam.
- Paper lamp  
Lights up when paper runs out.
- Feed switch  
Press this switch to feed the paper. Pressing this switch keeps paper feeding continuously.
- Mechanism lock lever  
This lock lever is used to pull down the printer mechanism to lift up the print head and to remove the paper manually. Or move the cutter blade in case the cutter blade is locked due to paper jam.
- Head - up lever  
This is the lever to lift up print head.
- Cutter blade(For CBM-290)  
Used to cut the paper manually.
- Mounting bracket  
Used to mount this equipment on the rack etc.
- Interface connector  
Connect a cable for power supply and interface to this connector.
- DIP switch  
Used to set the initial setting such as the type of interface (serial/parallel) or print density etc.
- FG terminal  
Used to earth the frame of main body. Connect it properly.
- Auto paper cutter (CBM-291 only)  
Paper is cut automatically by command. Complete full cut or partial cut (one tear point remains) can be specified.



## 3 Operation

### 3.1 Rack mounting

- (1) Put the main body into the rack as shown in the following drawing.
- (2) Hold the main body from rear side with mounting bracket, fasten the screws to fix the main body.
- (3) After mounting, make sure that front cover opens/closes properly.
- (4) In fasten screws, do not fasten the screws until the main body is deformed.  
This may be abnormal force onto the main body as well as be an cause of breakage.
- (5) Thickness of rack panel to fix the main body is to be approx. 1 - 3 mm.

! Cautions : For mounting bracket, length of the screws must be 15 mm or less.

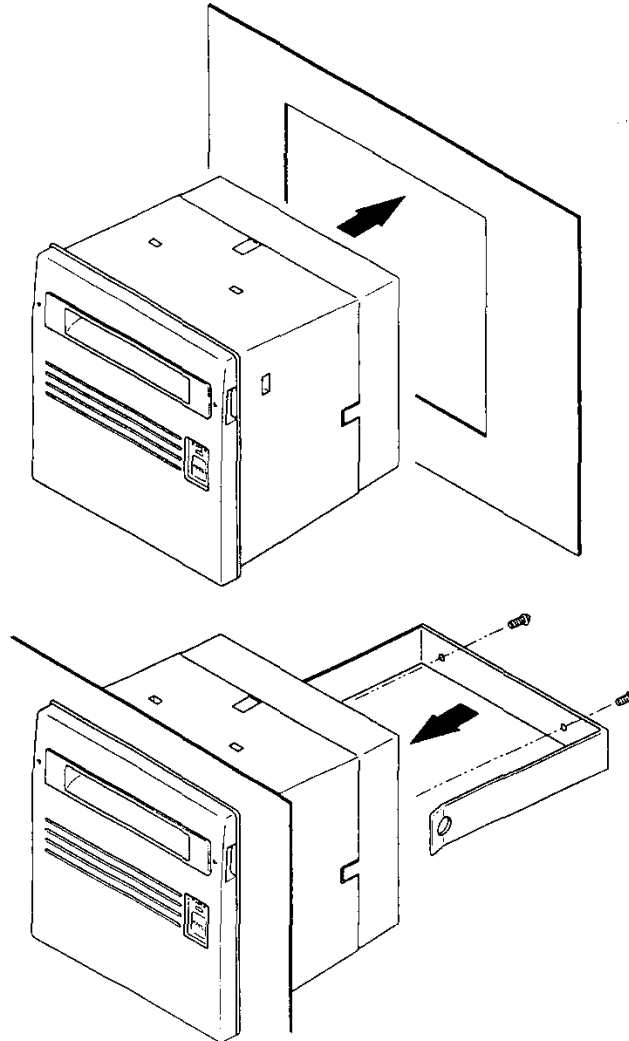

### 3.2 Connecting a cable for power supply and interface

- (1) Make sure that main power supply is turned OFF before connecting this cable.
- (2) Prepare power supply which satisfies the power voltage and current capacity specified in this manual.
- (3) Firmly connect, in appropriate direction, the power supply and the main body using this cable.

As shown in the drawing, this connector locates on the rear side of main body.

This cable integrates the cable for power supply and the cable for interface.

- (4) Connect this cable to external power supply.  
Pay attention not to connect power supply cable in reverse polar.
- (5) Earth the frame of main body.  
Earthing this is recommended to avoid noise and electronic statistic problem. For connecting, fix it with FG terminal on rear side properly.

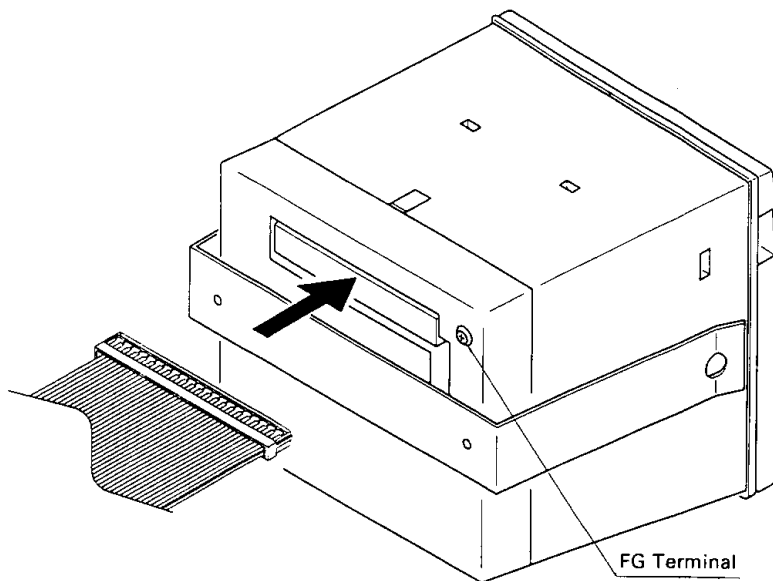

### 3.3 Opening/closing front cover

(1) Applying your finger on the projection on the left side of the front panel, pull it forward when the lock is released.

It opens by about 180 ° centering around the fixed axis.

(2) For closing, pressing the front panel, tightly close it until click sound is heard.

Also, confirm, on closing, that paper is free of slack.

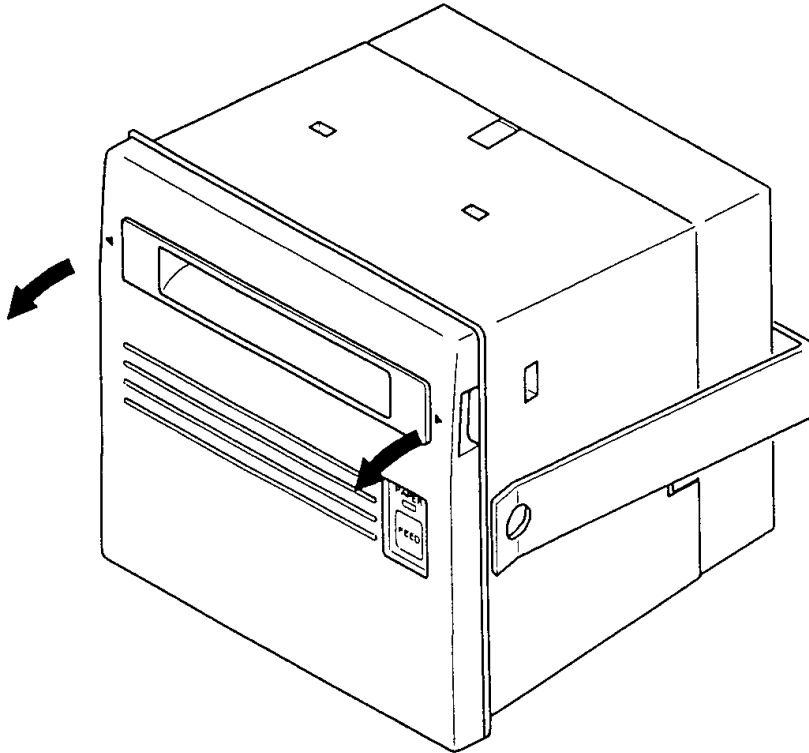

### 3.4 Paper feeding

With the LF switch pressed once, paper is fed by one line.

Paper is fed while it is continuously pressed.

Do not pull paper forcibly to feed paper. Use the LF switch.

While the front cover is open or printer mechanism is pulled down, paper can be fed. But, do not do this often. This may cause a paper jam, etc.

### 3.5 Auto paper loading function

This printer equips a function to feed the paper automatically when a new paper for replacement is inserted into paper inlet of printer mechanism.

This printer feeds paper automatically when the printer detects the paper in paper inlet.

### 3.6 Setting roll paper

1. Open the front cover.
2. Cut the edge of paper at a right or bent angle as the following drawing.  
Insert the edge of paper into the paper inlet of the printer mechanism.  
When paper is inserted into paper inlet in printer mechanism, paper is loaded automatically.
3. Make sure paper winding direction.
4. After setting paper, set roll paper inside of main unit.
5. Eliminating slack on the printing paper and close the front panel.
6. Feed paper by pressing Feed switch, if necessary.

\*Factory setting is Head up position.

Make sure to pull head up lever forward to pull down printer mechanism, Because auto paper feed can not be carried out at had up condition.

\*When any print data is remaining us print buffer, printer stars printing automatically after loading paper.

Make sure to pay attention to the followings.

1. In case that the paper is bent or the paper is not fed properly, set print head at head up condition and remove the paper carefully by turning paper feed knob.
2. For replacing roll paper, set print head at head up condition, and remove the paper which remains in printer unit carefully by turning paper feed knob.

### 3.7 Removing paper jam and canceling cutter lock

Remove paper jam or cancel cutter lock by following the procedure explained below.

- (1) Open front cover
- (2) Put mechanism lock lever inside of main body, pull down printer mechanism.  
When paper remains inside of printer, remove this paper.
- (3) Removing paper jam  
Remove paper jam manually with care. To pull out the paper from printer mechanism, pull it out carefully at head up condition.
- (4) Canceling cutter lock  
Remove paper inside of paper cutter and turn ON power. In case cutter blades to home position and carries out initializing, cutter lock was cleared completely.  
In case cutter does not return to home position or occurs some error again, turn OFF power, turn the knob which locates on left bottom side of auto cutter to the front side as shown in the below, then return cutter blade manually and remove the paper inside of auto cutter.
- (5) After fixing the problem, pull down head up lever and return printer mechanism to its home position.

! Caution : As print head and motor are hot, do not carry out this action right after printing.

This may cause burning from this heat.

For removing the remaining paper, do not touch the surface of print head and motor.

### 3.8 Self print function

By supplying power as pushing FEED switch or send RESET signal to this printer, type of characters which is used, ROM version and DIP switch setting etc are automatically printed. For CBM-291, paper is automatically cut off after this self printing.

### 3.9 PE and Mechanical alarm

#### 3.9.1 Paper end (PE)

This sensor detects the existence of paper. Printer stops printing when roll paper runs out, outputs BUSY and PE signal and lights up PAPER lamp.

When new roll paper is set, this signal is canceled and PAPER lamp lights off.

And then, printer starts printing and becomes data waiting status. When any print data is remaining in print buffer, make sure that printer starts printing the data after new roll paper is set.

#### 3.9.2 Mechanical alarm

This printer stops printing, stops supplying motor and print head with power and outputs BUSY signal and FAULT (in Parallel interface) signal to host computer, when the motor of printer mechanism is locked, auto paper cutter is locked, or temperature of print head is getting high.

In this case, turn OFF power supply and clear the problem. To make printer stand-by mode, turn ON power supply after clearing the problem.

Make sure that the data which is stored in the buffer is to be cleared due to power supply is turned OFF.

Absolutely, do not carry out clearing the problem during power is ON.

- Auto paper cutter lock, paper jam.

Turn OFF power supply and clear the problem. To make printer ready for print, turn ON power again after clearing the problem.

In this case, the print data which is remaining inside of print buffer is cleared due to power supply is turned OFF. Absolutely, do not carry out clearing problem supplying power.

- Head-up condition

Pull down had up lever forward. Print head is pulled down and error signal is cleared, then printer becomes ready for print.

- Heating up of print head temperature

When temperature of print head is getting high due to continuous printing etc., printer stops printing.

During temperature of print head is high, any operation is not available, keep printer without printing.

As soon as temperature of print head goes low, error signal is canceled automatically and printer becomes ready for print.

#### 4. Dip switch setting

Dip switch locates on the rear side of main body.

Make sure that power is turned OFF before changing Dip switch settings.

Change during power is ON can not be effective.

##### DIP SWITCH

		ON	OFF	FACTORY SETTING
DS1-1	AUTO CUTTER	EQUIPPED	NONE	OFF = CBM-290 ON = CBM-291
2	CR SELECTION	LF ENABLE	LF DISABLE	OFF
3	PRINT DENSITY	STANDARD	DARKER	OFF
4	DTR-DSR/XON-XOFF	XON-XOFF	DTR/DSR	OFF
5	INTERFACE	SEE BELOW		OFF
6	"			OFF
7	"			OFF
8	"			OFF

##### DS1-

8	7	6	5	INPUT METHOD	PARITY	BAUD RATE
OFF	OFF	OFF	OFF	PARALLEL INPUT	--	--
OFF	OFF	OFF	ON	SERIAL INPUT	NONE	1200 bps
OFF	OFF	ON	OFF	"	"	2400 bps
OFF	OFF	ON	ON	"	"	4800 bps
OFF	ON	OFF	OFF	"	"	9600 bps
OFF	ON	OFF	ON	"	"	19200 bps
OFF	ON	ON	OFF	"	ODD	1200 bps
OFF	ON	ON	ON	"	"	2400 bps
ON	OFF	OFF	OFF	"	"	4800 bps
ON	OFF	OFF	ON	"	"	9600 bps
ON	OFF	ON	OFF	"	"	19200 bps
ON	OFF	ON	ON	"	EVEN	1200 bps
ON	ON	OFF	OFF	"	"	2400 bps
ON	ON	OFF	ON	"	"	4800 bps
ON	ON	ON	OFF	"	"	9600 bps
ON	ON	ON	ON	"	"	19200 bps

Remarks : For CBM-290, It make Error when ON is selected for DS1-1.

DS1-4 is ignored when parallel input is specified.

Some specifications has been selected in factory setting by jumper as follows.

Jumper	International model	International model
J1	Short	International character : U.S.A.
J2	Short	Auto-loading : Enabled
J3	Short	Input Buffer : 4 K bytes
J4	Short	Serial communication bit length : 8 bit
J5	Short	
J6	Short	
J7	Short	
J8	Open	

## 5. Connecting connector

Configuration of the connector for power and interface which is packed in this box is as follows.  
Make sure to confirm the following configuration before connecting the connector.

### 5.1 Function of each connector pins

PIN NO.	SIGNAL NAME	I/O	FUNCTION
1 – 3	VCC	OUTPUT	POWER SUPPLY FOR CIRCUIT (+5V)
4 – 6	GND		GND
7 – 12	VP	INPUT	POWER SUPPLY FOR OPERATION(+24V)
13 – 18	P-GND		GND FOR OPERATION
19	-		Not available
20	ERROR	OUTPUT	ERROR LED OUTPUT (Can be connected directly.)
21			Not available
22	DTR	OUTPUT	SERIAL INTERFACE DTR
23	TXD	OUTPUT	SERIAL INTERFACE TXD
24	RXD	INPUT	SERIAL INTERFACE RXD
25	DSR	INPUT	SERIAL INTERFACE DSR
26	STB	INPUT	PARALLEL INTERFACE STROBE
27	BUSY	OUTPUT	PARALLEL INTERFACE BUSY
28	ACK	OUTPUT	PARALLEL INTERFACE ACK
29	DATA 0	INPUT	PARALLEL INTERFACE DATA 0
30	DATA 1	INPUT	PARALLEL INTERFACE DATA 1
31	DATA 2	INPUT	PARALLEL INTERFACE DATA 2
32	DATA 3	INPUT	PARALLEL INTERFACE DATA 3
33	DATA 4	INPUT	PARALLEL INTERFACE DATA 4
34	DATA 5	INPUT	PARALLEL INTERFACE DATA 5
35	DATA 6	INPUT	PARALLEL INTERFACE DATA 6
36	DATA 7	INPUT	PARALLEL INTERFACE DATA 7
37	PE	OUTPUT	PARALLEL INTERFACE PE
38	FAULT	OUTPUT	PARALLEL INTERFACE FAULT
39	RESET	INPUT	PARALLEL INTERFACE RESET
40	-	-	Not available

Using connector : LY20-40P-DT1-P5 (JAE) or equivalent

Applicable connector : LY10-DC40 (JAE) or equivalent



## 5.2 Precautions

1. For LED ERROR , there is a resistor of 330 Ohm on the circuit side to make current value 10 mA. Please use LED which its voltage is approx. 2V. LED over 10 mA may break a control board.
2. Make sure to supply power to all pins of power supply for circuit and power supply for operation to keep required current capacity.
3. Serial interface equips a driver and receiver of RS-232C, make sure to use it at RS-232C level.
4. RESET terminal is pulled up by 3.3K Ohm. Make sure to make this terminal NC, when this terminal is not used.
5. Absolutely, do not carry use No.19, No.21 and No.40 pins. Since they are used for printer main unit. In case they are used, they may cause abnormality or break control board.

## 6 Parallel Interface

### 6.1 Specifications

Data input method : 8 bit parallel signal (DATA0 - 7)

Control signals :  : ACK, BUSY, STB, FAULT, PE, RESET

### 6.2 Explanation of input / output signals

DATA0-7 : 8 bit parallel signal (Positive logic)

 STB : Strobe signal to read 8 bit data (Positive signal)

 RESET : Signal to reset control board

 ACK : 8 bit data request signal. Pulse signal output at the end of the BUSY signal (Negative logic)

BUSY : Signal to indicate BUSY state of the printer. Input new data for "LOW" (Positive logic)

 FAULT : Signal which is made "LOW" when printer is in alarm state.(Negative logic)

PE : Signal which is output when paper runs out.(Positive logic)

### 6.3 Electrical characteristics

#### (1) Input Signal Level

All the input signals are at TTL level.

"HIGH" level :  $0.7V_{cc}$  MIN

"LOW" level :  $0.3V_{cc}$  MAX

#### (2) Output Signal Level

All the input signals are at TTL level.

"HIGH" level :  $V_{cc} - 0.1V$  MIN

"LOW" level :  $0.1V$  MAX

#### (3) I/O Conditions

Input signal of STB and RESET are pulled up by 3.3K Ohm. Others are pulled up by 50K Ohm.

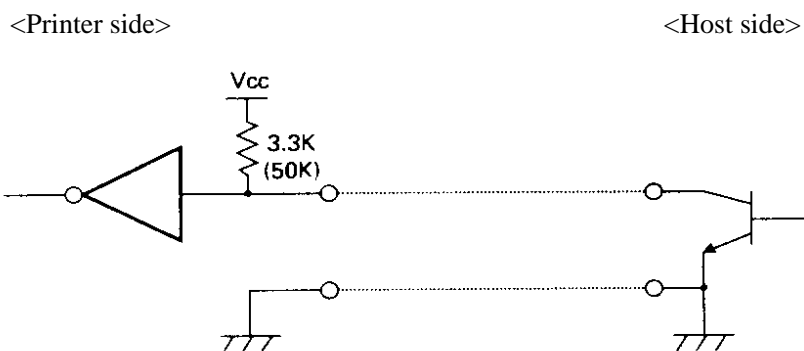

All the output signals are pulled up by 50K Ohm.

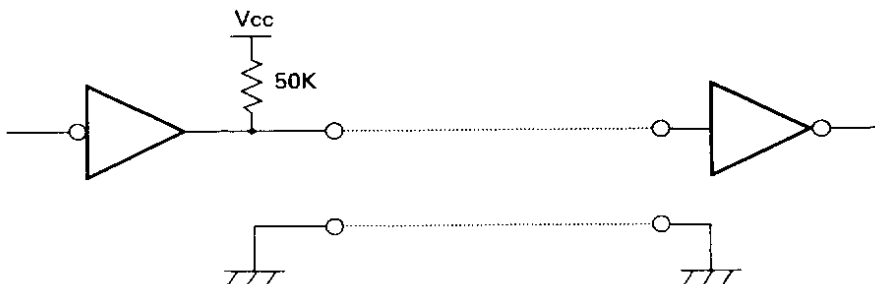

## 6.4 Timing chart

### (1) Data Input and Printing Timing

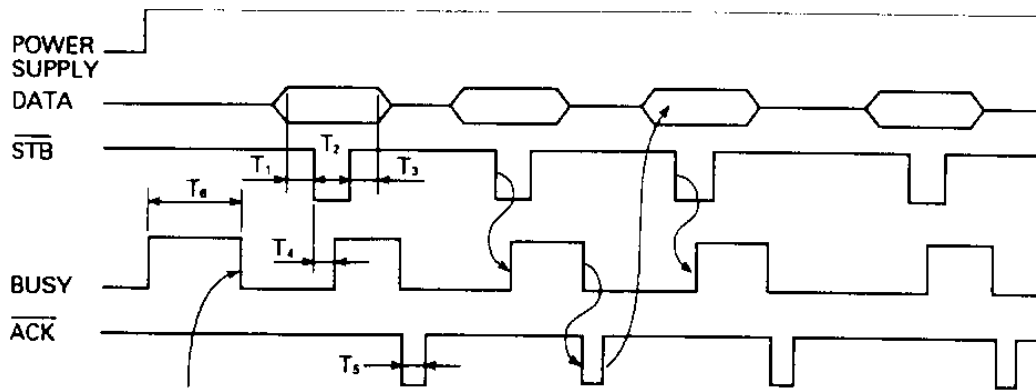

ACK is not outputted.

T1, T2, T3	: 0.5 micro sec. MIN
T4	: 270 ns MAX
T5	: 2.3 micro sec. TYP
T6	: 500 ms MIN (On supplying power)

## 6.5 Data receiving control

When BUSY signal is "LOW", data from the host can be received. When it being "HIGH", data can not be received.

## 6.6 Buffering

4 K bytes input buffer is incorporated. Due to this large buffer, host side is released immediately.

## 7 Serial Interface

### 7.1 Specifications

(1) Data transfer system: Asynchronous

(2) Baud rates

1200, 2400, 4800, 9600, 19200 bps (Selectable by user)

(3) Configuration of one word

Start bit : 1 bit

Data bit : 8 bits

Parity bit : Add/even or no parity (Selectable by user)

Stop bit : 1 bit or more

(4) Signal polarity

RS-232C

● Mark = logic "1" (-3V - -12V)

● Space = logic "0" (+3V - +12V)

(5) Receiving data (RD signal)

RS-232C

● Mark = 1

● Space = 0

(5) Receiving control (DTR signal)

RS-232C

● Mark : Data transfer not available

● Space : Data transfer available

(6) Transmission control (TD signal)

DC1 code (11H) X-ON : Data reception available

DC3 code (13H) X-OFF : Data reception not available

## 7.2 Explanation of Input / Output signals

### 7.2.1 Input / Output signals

(1) RD

Serial receiving data signal. On occurrence of framing error, overrun error, or parity error, the data is printed as "?".

(2) DTR

When this signal is READY, write data or a command. When they are written in BUSY, overrun error is occurred and data is ignored. Even during printing, data can be loaded in the input buffer. Further, BUSY can take place on supply of power, during test printing, during on-line, or on resetting.

(3) TD

When, while in data reception, the rest of input buffer on the printer side goes less than 128 bytes, DC3 (13H) data reception impossible signals are output.

When the rest of input buffer goes more than 256 bytes, DC1 (11H) data reception possible signals are output to the host. When DTR/DSR control having been selected in status information transmission, it is first confirmed that DSR is "space" and data is sent.

When DTR/DSR control has not been selected, DSR is ignored and data is transmitted.

(4) FG

Case GND

(5) GND

Common GND on the circuit.

### 7.3 Date configuration

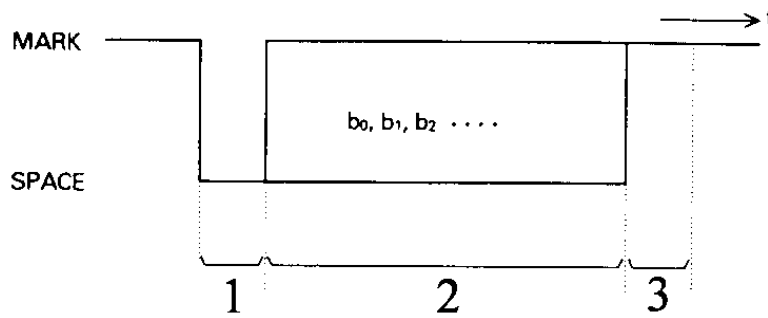

- 1 Start bit
- 2 Data bit (+ parity bit)
- 3 Stop bit ( 1 or more )

- (1) Start Bit  
In 1/2 bit from the mark-to-space starting edge, state is read once again. When "space" state is confirmed, it is recognized as the start bit. If it is "mark" state, it is not taken as the start bit. Without taking it as an error, detection of a start bit is carried out once again.
- (2) Data Bit + Parity Bit  
Data bit and parity bit are sampled at 1/2 start bit for time length equal to 1 bit. The state thus sampled is taken as the data for the bit concerned. Bits are named as Bit 0, Bit 1, ..... parity bit counted from the one close to the start bit.
- (3) Stop Bit  
The stop bit is a mark level of 1 bit or more. With "space" having been detected on detection of a stop bit, framing error takes place.

### 7.4 Error detection

Parity, framing, and overrun are detected. On detection of any error, the data are stored in the buffer as "?".

#### (1) Framing Error

With "space" state having been detected on detection of a stop bit, error takes place. The data are stored in the buffer as "?".

#### (2) Parity Error

With an error having been detected under specifying parity check, the data is stored in the buffer as "?".

#### (3) Overrun Error

On detection of an overrun error, the data are stored in the buffer as "?".

### 7.5 Data receiving control

When DTR/DSR control having been selected, with BUSY signal at "LOW", data from the host side are received. With the signal at "HIGH", they can not be received.  
 When DTR/DSR control not having been selected, after X-ON transmission, data is received from the host side. No transmission of data can take place after X-OFF is transmitted.

### 7.6 Buffering

Data transfer to the input buffer include DTR signals and TD signals as the control signals concerned.

- (1) DTR signals (See 7.2. (2).)
- (2) TXD signals (See 7.2. (3).)

### 7.7 Electrical characteristics

(1) RS-232C Circuit

Input (RXD, DSR)

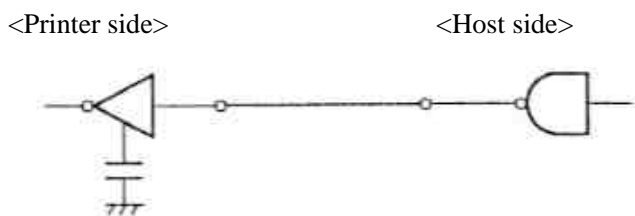

MAX 232 equivalent

RXD Mark = (-8V) : Stop bit  
 Space = (+8V) : Start bit

Output (DTR, TXD)



MAX 232 equivalent

DTR (-8V) : When busy  
 (+8V) : When ready  
 TXD Mark = (-8V) : 1  
 Space = (+8V) : 0

## 8. Print Control Function

### 8.1 Command List

	CONTROL CODE	FUNCTION
1	HT	Horizontal tab command
2	CR	Print command
3	LF	Printing and paper feed
4	ESC SP	Setting the right space amount of the character
5	!	Collective specifying printing mode
6	%	Specifying/canceling download character set
7	&	Defining download characters
8	*	Specifying the bit image mode
9	-	Specifying/canceling underline
10	2	Specifying 1/6-inch line feed rate
11	3	Setting line feed rate of minimum pitch
12	@	Initializing the Printer
13	D	Setting horizontal tab position
14	E	Specifying/canceling highlighting
15	G	Specifying/canceling double printing
16	J	Printing and feeding paper n/203 inch
17	R	Selecting the international characters
18	c3	Nop
19	c4	Nop
20	c5	Enabling/disabling the panel switches
21	d	Printing and feeding the paper by n lines
22	p	NOP
23	t	Selecting the character code table
24	v	Transmitting the printer status (Serial type)
25	u	NOP
26	{	Specifying/canceling the inverted characters
27	V	Specifying/canceling the 90° - right-turned characters
28	\$	Specifying the absolute positions
29	¥	Specifying the relative positions
30	GS k	Printing the bar code
31	w	Selecting the horizontal size (scale factor) of bar code
32	h	Selecting the height of the bar code
33	H	Selecting of print position of HRI code
34	f	Selecting the font of HRI code
35	*	Defining the download bit image
36	/	Printing the download bit image
37	:	Starting/ending macro definition
38	^	Executing the macro
39	ESC =	Data input control
40	a	Aligning the characters
41	i	Activating auto cutter (Full cut)
42	m	Activating auto cutter (Partial cut)



## 8.2 Command Details

### (1) Horizontal Tab Command (HT)

Code : (09)h

Shifts the printing position to the next horizontal tab position. The horizontal tab position is set by ESC D. Initial setting of the horizontal tab position is each 8 characters in 9th, 17th, 25th, 33rd columns.

### (2) Print Command (CR)

Code : (0D)h

1) When DS 1 -2 is OFF:

This command is ignored.

2) When DS 1- 2 is ON:

With data held inside the internal print buffer, printing and line feed are performed.

Without data inside the internal print buffer, however, no printing is performed.

### (3) Printing and Paper Feed Command (LF)

Code : (0A)h

Prints data inside the input buffer and feeds lines based on the line feed amount having been set.

### (4) Setting the right space amount of the characters (ESC SP n)

Code : (1B)h + (20)h + n

\* {0 ≤ n ≤ 20} Data is described in Hex code.

The rightward space amount is set in dot unit (1/203 inch unit). In the initial value, it is n=0.

The rightward space amount in double wide mode is made double of the set volume.

### (5) Collective Specifying Printing Mode (ESC ! n)

Code: (1B)h + (21)h + n

\* {0 ≤ n ≤ FF} Data is described in Hex code.

Printing mode is assigned. Each n bit indicates the following:

BIT	FUNCTION	VALUE	
		0	1
0	Character Font	Font A	Font B
1	Undefined		
2	Undefined		
3	High-lighting	Canceled	Specified
4	Double height	Canceled	Specified
5	Double width	Canceled	Specified
6	Undefined		
7	Underline	Canceled	Specified

- With double height and double width being specified simultaneously, double wide and double high characters are consisted.
- An underline is attached to the full character width, which, however, is not attached to the part having been skipped by the horizontal tab. Neither is it attached to 90°-right-turned characters.
- The underline width is as having been specified by <ESC - >. (The default setting is 1 dot width. )  
In case that double wide character and normal character exist in same one line, the layout of underline is consistent one.

(6) Specifying/Canceling Download Character Set (ESC % n)

Code: [1B]h + [25]h + [n]

\* {0 ≤ n ≤ FF} data is described in Hex code.

Specifying/canceling download characters. Download characters and download bit images cannot be defined simultaneously. Further, only the lowest bit (n0) is valid for n.

The lowest bit (n0) indicates the following.

n0	Function
0	Canceling download character
1	Specifying download character

(7) Defining Download Character (ESC & s n m a (D1D2 - Dn))

Code: [1B]h + [26]h + s + n + m + a + Dn

\* {s = 03}

{20 (Hex) ≤ n ≤ 7E (Hex)}

{20 (Hex) ≤ m ≤ 7E (Hex)}

{0 ≤ a ≤ 0A (Hex)}

Defines the font of download characters of alphanumeric characters.

- "s" indicates the number of bytes in vertical direction.
- "n" indicates the start character code and m the end character code. To define only one character, set n=m.
- Character codes definable includes 95 ASCII codes in total between <20>H - <7E>H.
- "a" indicates the number of dots in horizontal direction for definition.
- Dn is the data to be defined, which indicate a pattern equal to "a" dot in horizontal direction from the left end. The rest of the pattern on the right side is filled with space. The rest of data to be defined is s x a.
- Download characters thus defined remain valid until redefinition, ESC @ execution, GS \* execution, or power OFF is practiced.

[EXAMPLE]

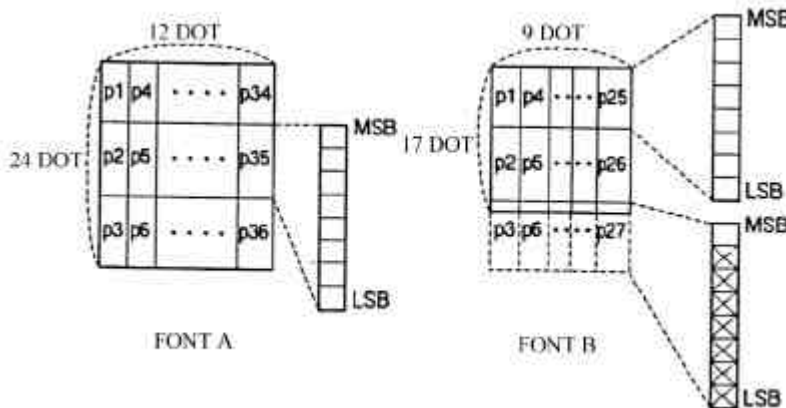

(8) Specifying the Bit Image Mode (ESC \* m n1 n2 D1 - Dn)

Code : [1B]h + [2A]h + m + n1 + n2 + Dn

\* {m= bit image mode (See the table below.)}

{0 ≤ n1 ≤ FF}

{0 ≤ n2 ≤ 02} Data is described in Hex code.

According to the number of dots specified in n1, n2, specify the bit image of mode n.

- The no. of dots printed is divided by 256, whose quotient is taken as n2 and residual as n1.
- The total no. of dots printed in the bit image is equal to n1 + (256 x n2).
- When bit image data have been input in excess of dot position of one line (448 dots), the excess data are discarded.
- d is bit image data, the bits subject to printing are taken as "1" and those not as "0".
- The bit image modes specified by m are shown as follows:

m(Hex)	MODE	VERTICAL DIRECTION		HORIZONTAL DIRECTION	
		NO. OF DOTS	DOT DENSITY	DOT DENSITY	MAX. NO OF DOTS
0	8-dot single density	8	67 DPI	101 DPI	224 (208)
1	8-dot double density	8	67 DPI	203 DPI	448 (416)
32	24-dot single density	24	203 DPI	101 DPI	224 (208)
33	24-dot double density	24	203 DPI	203 DPI	448 (416)

- When the values set in m (bit image mode) are out of the above range, the data following after n1 is processed as normal printing data.
- After completion of bit image printing, printer returns to normal data processing mode.

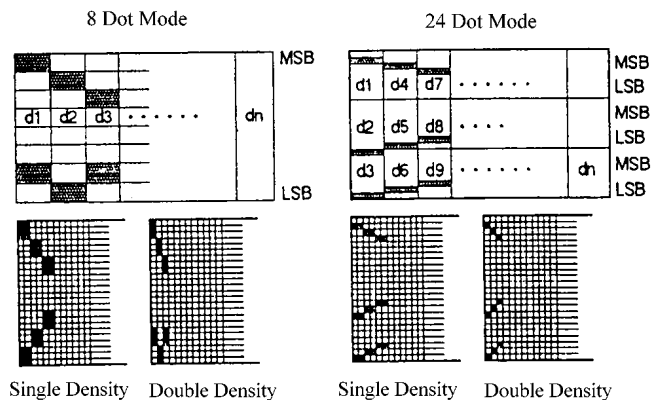

(9) Specifying/ Canceling Underline (ESC - n)

Code: [1B]h + [2D]h + n

\* {0 ≤ n ≤ 02} data is described in Hex code.

Specifying/canceling an underline.

- An underline is attached to the full character width. It is, however, not attached to the part having been skipped by horizontal tab command.
- An underline is not attached to a 90° - right-turned characters.
- Types of underlines by n value are shown below:

n (Hex)	Type
0	Canceling an underline.
1	Specifying an underline for 1-dot width.
2	Specifying an underline for 2-dot width.

(10) Specifying 1/6 inch line feed rate (ESC 2)

Code : [1B]h + [32]h

The line feed rate per line is specified by 1/6 inch.

(11) Setting line feed rate of minimum pitch (ESC 3 n)

Code : [1B]h + [33]h + n

\* {0 ≤ n ≤ FF} data is described in Hex code.

The line feed rate per line is specified by n/360 inch.

- The initial value is n = 60(1/6 inch)(18H), being 4.23 mm line feed rate.

(12) Initializing Printer (ESC @)

Code : [1B]h + [40]h

Clears data stored in the print buffer and brings various settings to the initial state (Default state).

- Data inside the internal input buffer are not cleared.
- Dip switches setting are read once again.

(13) Setting Horizontal Tab Position (ESC D n NUL)

Code : [1B]h + [44]h + n [00]h

\* {0 ≤ n ≤ FF} Data is described in Hex code.

Specifying a horizontal tab position.

- "n" indicates the no. of columns from the beginning to the horizontal tab position. At this time, n= set position - 1 is to be specified. For example, to set the position at 9th column, n=8 is to be specified.
- The tab position is set at position where it is "character width x n" from the line beginning. The character width, at this time, includes the rightward space amount. In double wide characters, it is made double of the ordinary case.
- Tab positions can be specified are maximum 32. Specifying exceeding this is ignored.
- ESC D NUL clears all the set tab positions. Following clearing, horizontal tab command is ignored.
- Initial value is specified for each eight characters(9.17.25.33.) of ANK characters.

(14) Specifying/canceling highlighting (ESC E n)

Code : [1B]h + [45]h + n

\* {0 ≤ n ≤ FF} Data is described in Hex code.

Specifying/canceling the highlighting characters.

- "n" is valid only for the lowest bit (n0).
- Control by the lowest bit (n0) is shown as follows:

n0	Type
0	Canceling highlighting.
1	Specifying highlighting.

- This is effective to all characters.
- Dot configuration of a highlighted character includes one extra dot added at its side.
- The print result of Double printing and highlight character printing is completely same.

(15) Specifying/canceling Double Printing (ESC G n)

Code : [1B]h + [47]h + n

\* {0 ≤ n ≤ FF} Data is described in Hex code.

Specifying/canceling the double printing.

- "n" is valid only for the lowest bit (n0).
- Control by n is shown as follows.

n0	Type
0	Canceling double printing.
1	Specifying double printing.

- The print result of Double printing and highlight character printing is completely same

(16) Printing and feeding paper at minimum pitch (ESC J n)

Code : [1B]h + [4A]h + n

\* {0 ≤ n ≤ FF} Data is described in Hex code.

Prints data inside the print buffer and feeds paper by n/360 inch.

- Specified volume does not remain.
- The beginning of the line is to be considered as the next printing start position.
- Initial value is not defined.

(17) Selecting International Characters (ESC R n)

Code : [1B]h + [52]h + n

\* {0 ≤ n ≤ 0A} Data is described in Hex code.

Selecting international characters.

- Depending on the value of n, following character sets are specified.

n(Hex)	CHARACTER SET
0	U.S.A.
1	France
2	Germany
3	U.K.
4	Denmark 1
5	Sweden
6	Italy
7	Spain
8	Japan
9	Norway
10	Denmark 2

- The initial value of n indicates the character set specified by Jumper setting (J1 - J3).

(18) NOP (ESC c3)

(19) NOP (ESC c5)

(20) Enabling/Disabling Panel Switch (ESC c 5 n)

Code : [1B]h + [63]h + [35]h + n

\* {0 ≤ n ≤ FF} Data is described in Hex code.

Selecting the LF switch valid/invalid.

- "n" is valid only in the lowest bit (n0).
- "n" bit means the followings.

N0	Condition
0	LF SW valid.
1	LF SW invalid.

- The initial value of n is "0".

(21) Printing and Feeding the paper by n lines (ESC d n)

Code : [1B]h + [64]h + n

\* {0 ≤ n ≤ FF} Data is described in Hex code.

Prints data inside the buffer and feeds paper by n lines.

- Specified line does not remain.
- The beginning of the line is to be considered as the next printing start position.
- The initial value is not defined.

(22) Generating specified Pulse (ESC p m n1 n2)

Code : [1B]h + [70]h + m + n + n2

\* {m = connector pin No. (See table below.)}

{0 ≤ n1 ≤ FF}

{0 ≤ n2 ≤ FF} Data is described in Hex code.

Signals specified by n1, n2 are output to Connector Pin m.

- Bit m (m0) means the followings.

m0	Condition
0	Drawer kick No. 2 pin
1	Drawer kick No. 5 pin

- ON time is considered as n1 x 2ms and OFF time as n2 x 2ms.
- When m is out of the defined range, n1, n2 are discarded, where no signals are output.
- Drive duty of Drawer is shown below:

$$\frac{\text{ON time}}{\text{ON time} + \text{OFF time}} \leq 0.2$$

(Take OFF time as being 4 times or more longer than ON time.)

(23) Selecting Character Code Table (ESC t n)

Code : [1B]h + [74]h + n

\* {0 ≤ n ≤ 1} Data is described in Hex code.

Selecting Page n on the character code table:

- "n" means the followings.

n (Hex)	Condition
0	IBM Character #2
1	Japanese Character

- The initial value of n is specified by Jumper setting (J1 - J3).

(24) Transmitting the printer status (ESC v)

Code : [1B]h + [76]h

Current printer status is transmitted..

- Status sent out consists of 1 byte whose content is as in the table below.
- In DTR/DSR control, after receivable state of the host (DSR signal being in SPACE state) is confirmed, only 1 byte is transmitted. In XON/XOFF control, DSR signal state not being confirmed, only 1 byte is transmitted.
- In DTR/DSR control, when the host is in unreceivable state(DSR signal being in MARK state), it waits until receivable state is created.
- In paper end (paper near end) status, this command may be unreceivable state due to BUSY state.

Remarks. This command is valid only for serial interface model.

BIT	FUNCTION	VALUE	
		0	1
0	Not defined		
1	Not defined		
2	Paper end	With paper	Without paper
3	Not defined		
4	Not used	Fixed to 0	-
5	Not defined		
6	Not defined		
7	Not defined		

(25) Transmitting the status of Peripheral Equipment (ESC u n)

Code : [1B]h + [75]h + n

\* {n = 0}

Current status of connector pin No.3 is transmitted.

- "n" means the followings.

n (Hex)	Condition
0	Drawer Kick Connector No. 3

- Status transmitted consists of 1 byte whose content is as in the table below.
- Any equipment has not been connected to this connector, Bit 0 of n is always "1".
- In DTR/DSR control, after receivable state of the host (DSR signal being in SPACE state) is confirmed, only 1 byte is transmitted. Further, in XON/ XOFF control, DSR signal state not being confirmed, only 1 byte is transmitted.
- In DTR/DSR control, when the host is unreceivable state (DSR signal being in MARK state), it keeps waiting until receivable state is created.

BIT	FUNCTION	VALUE	
		0	1
0	Not defined		
1	Not defined		
2	Paper end	Paper remains	Paper out
3	Not defined		
4	Not used	Fixed to 0	-
5	Not defined		
6	Not defined		
7	Not defined		

Remarks :This command is valid only for serial interface mode.

(26) specifying/Canceling Inverted Characters (ESC { )

Code : [1B]h + [7B]h + n

\* {0 ≤ n ≤ FF} Data is described in Hex code.

Specifying/canceling inverted characters.

- "n" is valid only for the lowest bit (n0).
- Bit n (n0) means the followings.

n0	Condition
0	Canceling inverted characters.
1	Specifying inverted characters.

- Inverted printing means printing the line at 180° turned.
- This is valid only when this is specified at the beginning of a line.
- The initial value of n is "0".

(27) Specifying/Canceling 90° -right- turned Characters (ESC V n)

Code : [1B]h + [56]h + n

\* {0 ≤ n ≤ 1} Data is described in Hex code.

Specifying/canceling characters 90°-right- turned character.

- No underlines are attached to 90°-right- turned characters .
- "n" means the followings.

n (Hex)	Condition
0	Canceling 90° -right- turned Characters
1	Specifying 90° -right- turned Characters

- The initial value of n is "0".

(28) Specifying Absolute Positions (ESC \$ n1 n2)

Code : [1B]h + [24]h + n1 + n2

\* {0 ≤ n1 ≤ FF}

{0 ≤ n2 ≤ 1} Data is described in Hex code.

The printing start position is specified in the number of dots from the beginning of line.  
(1/20 inch unit)

- The number of dots is divided by 256, whose quotient is taken as n2 and the residual as n1. Therefore, the printing start position is equal to n1 + n2 x 256 from the beginning of line..
- Specifying beyond the line end is ignored.
- In case underline is specified, no underline is provided to the skipped portion.

(29) Specifying Relative Positions (ESC ¥ n1 n2)

Code : [1B]h + [5C]h + n1 + n2

\* {0 ≤ n1 ≤ FF}

{0 ≤ n2 ≤ FF} Data is described in Hex code.

The printing start position is specified in the number of dots from the current position.

- Rightward direction is taken as plus and leftward direction as minus.
- To specify N dot in minus (left) direction, use a complement of N for assignment.  
- N dots = 65536 - N
- The number of dots is divided by 256, whose quotient is taken as n2 and the residual as n1.
- Specifying exceeding the end of line is ignored.
- In case underline is specified, no underline is provided to the skipped portion.



(30) Bar Code Printing (GS k n Dn NUL)

Code : [1D]h + [6B]h + n + Dn + [00]h

\* {0 ≤ n ≤ 7} Data are described in Hex code.

Specifying a type of bar code and printing bar codes.

- The beginning of line is considered as the next printing start position.
- Depending on the value of n, the following bar code can be selected.
- Dn indicates a character code to be printed.

n (Hex)	Bar Code System	Maximum Columns
0	UPC-A	---
1	UPC-E	---
2	JAN13 (EAN)	---
3	JAN 8 (EAN)	---
4	CODE 39	14
5	ITF	24
6	CODABAR (NW-7)	18
7	CODE 128	15

- When data being held in the print buffer, this command is ignored.
- Regardless of the specified feed pitch, this command feeds the paper to be required to print a bar code.
- When the character code Dn cannot be printed, the data following after this is printed as ordinary print data.
- When a bar code whose number of characters to be printed is fixed has been selected, the number of characters have to be always made equal to the number of characters to be printed.
- When the horizontal direction exceeds one line length, the excess part is not printed.

(31) Selecting Bar Code width (GS w n)

Code : [1d]H + [77]H + N

\* {2 ≤ n ≤ 4} Data is described in Hex code.

Selecting bar code width.

- The initial value of this width is "3".

(32) Selecting Bar Code Height (GS h n)

Code : [1d]H + [68]H + N

\* {1 ≤ n ≤ FF} Data is described in Hex code.

Selecting bar code height.

- "n" indicates the number of dots in vertical direction.
- The initial value of n is "162".

(33) Selecting Printing Position of HRI Characters (GS H n)

Code : [1d]H + [48]H + N

\* {0 ≤ n ≤ 3} Data is described in Hex code.

Selecting printing position of HRI characters in printing bar codes.

- "n" means the followings.

n (Hex)	Printing Position
0	No printing
1	Above the bar code
2	Below the bar code
3	Both above and below the bar code

- The initial value of n is "0".

(34) Selecting the font of HRI code (GS f n)

Code : [1D]h + [66]h + N

\* n = 0, 1

Selecting the font of HRI code in printing bar code.

The type of font can be printed by selecting n is as follows.

n	Font
0	Font A
1	Font B

(35) Defining Download Bit Image (GS \* n1 n2 Dn)

Code : [1D]h + [2A]h + n1 + n2 Dn

\* {1 ≤ n1 ≤ FF}

{1 ≤ n2 ≤ 48}

{n1 X n2 ≤ 1311} Data is described in Hex code.

Defines downloading bit images of the number of dots specified by n1/n2.

- The numbers of dots are n1 x 8 in horizontal direction and n2 x 8 in vertical direction.
- Dn indicates bit image data.
- The download bit image thus defined remains effective until redefinition, ESC @ execution, ESC &, or power OFF takes place.
- A download character and a download bit image cannot be defined simultaneously. With this command executed, defined content of a download character is cleared.
- Relations between the bit image data and the dot defined are shown below:

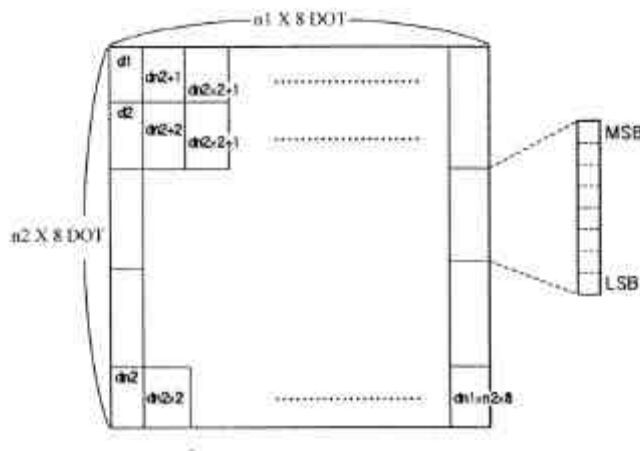

(36) Printing Download Bit Image (GS / m)

Code : [1D]h + [2F]h + m

\* {0 ≤ m ≤ 3} Data is described in Hex code.

Prints download bit iamges in a mode specified by m.

- Modes can be selected by m are shown in table for selection with m are shown below.

m	MODE NAME	DOT DENSITY IN VERTICAL DIRECTION	DOT DENSITY IN HORIZONTAL DIRECTION
0	Normal mode	203 DPI	203 DPI
1	Double wide mode	203 DPI	101 DPI
2	Double high mode	101 DPI	203 DPI
3	Double wide/double high mode	101 DPI	101 DPI

- When data exist inside the print buffer, this command is ignored.
- When a download bit image has not been defined, this command is ignored.
- A portion of a download bit image exceeding one line length is not printed.
- A download character and a download bit image cannot be defined simultaneously.

(37) Starting / Ending Macro Definition (GS :)

Code : [1D]h + [3A]h

Specifying starting / ending macro definition. Maximum content available for macro definition is 2048 bytes. A portion exceeding 2048 bytes is not defined.

- Even with ESC @ (initialization of the printer) having been executed, defined content is not cleared. Therefore, it is possible to include ESC @ into the content of macro definition.
- Normal printing operation is carried out even while in macro definition

(38) Macro Execution (GS ^ n1 n2 n3)

Code : [1D]h + [5E]h + n1 + n2 + n3

\* {0 ≤ n1 ≤ FF}

{0 ≤ n2 ≤ FF}

{0 ≤ 3 ≤ 1} Data is described in Hex code.

Executing contents defined in macro.

- "n1 - n3" indicate as follows:
  - n1 : The number of times of macro execution
  - n2 : Waiting time on macro execution  
Waiting time of n2 x 100 msec is given for every execution.
  - n3 : Macro execution mode

n3	Mode
0	Continuous execution
1	Execution by LF SW

Continuous execution : The Macro is executed n1 times continuously at the time intervals specified by n2.

Execution by FEED SW : After waiting for lapse of time specified by n2, the ERROR LED flickers and the LF switch is waited to be pressed. When it is pressed, the macro is executed once. This action is repeated n1 times.

- When this command is received while in macro definition, suspension of macro definition is indicated. At this time, the defined content is cleared.
- No execution takes place when macro is held undefined or n1=0.
- While in macro execution with n3=1, paper feed with the LF SW is not available.

(39) Data Input Control (ESC = n)

Code : [1B]h + [3D]h + n

\* {0 ≤ n ≤ FF} Data is described in Hex code.

Selecting equipment in which data input from the host is effective.

- Each bit of n indicates as follows:

BIT	EQUIPMENT	VALUE	
		0	1
0	Printer	Invalid	Valid
1	Not defined		
2	Not defined		
3	Not defined		
4	Not defined		
5	Not defined		
6	Not defined		
7	Not defined		

- When the printer has not been selected, this printer abandons all the received data until it is selected by this command.
- Even when the printer has not been selected, it can become BUSY state through printer operation.
- The initial value of n is "1".

(40) Aligning the characters (ESC a n)

Code : [1b]h + [61]h + n

\* {0 ≤ n ≤ 2} Data is described in Hex code.

All the printed data within one line are aligned in the specified position.

- Depending on n value, positional alignment is carried out as in the table below:

n (Hex)	POSITION
0	Left end alignment
1	Centering
2	Right end alignment

- This is valid only when n is inputted at the beginning of line.
- The initial value of n is "0".

(41) Full Cut (ESC i)

Code : [1B]h + [69]h

Activating auto cutter (Full cut)

- This is valid only when n is inputted at the beginning of line.
- Make sure to feed the paper by 18 mm or more before cutting paper, unless characters remain before the cutting point.

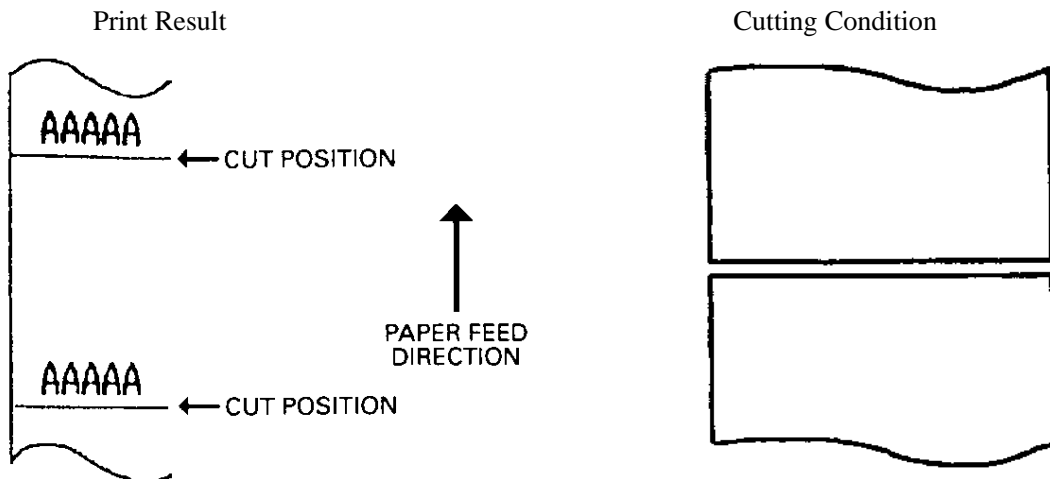

(42) Partial Cut (ESC m) (In selection of cutter option)

Code : [1B]h + [6D]h

Activating auto cutter unit (Partial cut)

- This is valid only when n is inputted at the beginning of line.
- Make sure to feed the paper by 18 mm or more before cutting paper, unless characters remain before the cutting point.

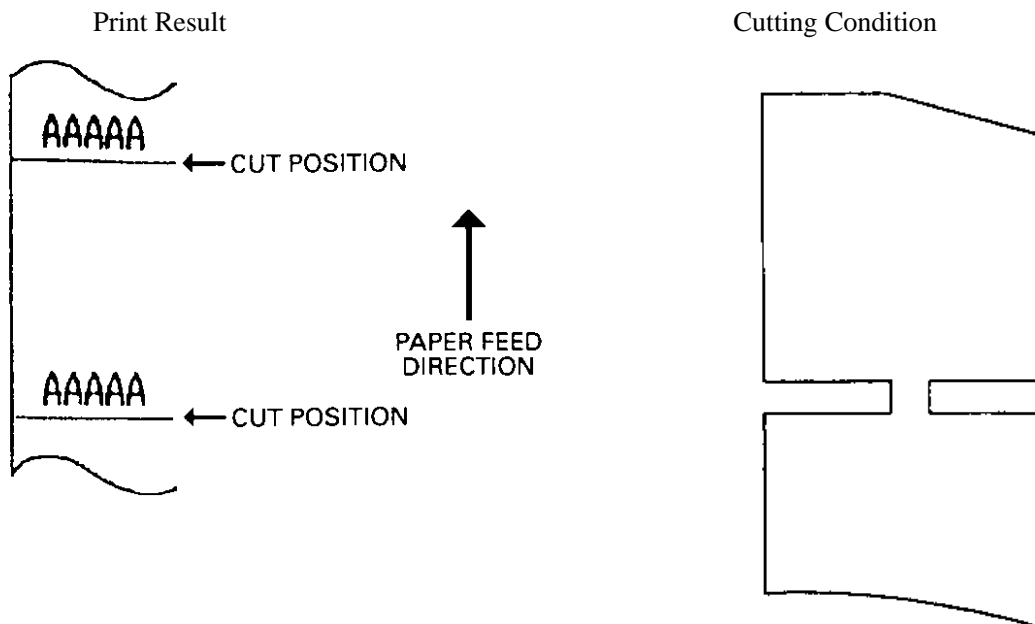

# 9. Character Table

## 9.1 International

	0	1	2	3	4	5	6	7	8	9	A	B	C	D	E	F
0	sol		SP	0	@	P	'	p	ç	é	á	☒	L	⊥	α	■
1		sol		1	A	Q	a	q	ú	z	l	☒	⊥	⊥	β	±
2		'	·	2	B	R	b	r	é	λ	ó	☒	T	T	Γ	≠
3		sol	#	3	C	S	c	s	á	ó	ú		⊥	⊥	κ	≠
4			\$	4	D	T	d	t	a	ó	ñ	⊥	—	⊥	Σ	Γ
5			%	5	E	U	e	u	a	ó	ñ	⊥	⊥	⊥	σ	Γ
6			&	6	F	V	f	v	á	ú	í	⊥	⊥	⊥	μ	÷
7			'	7	G	W	g	w	ç	ú	í	⊥	⊥	⊥	τ	≈
8			(	8	H	X	h	x	é	γ	¿	⊥	⊥	⊥	Φ	·
9	HT		)	9	I	Y	i	y	e	ó	í	⊥	⊥	⊥	θ	·
A	LP		*	:	J	Z	j	z	é	ó	í		⊥	⊥	Ω	·
B		esc	+	:	K	[	k	[	í	é	⊥	⊥	T	■	δ	√
C		PS	,	<	L	\	l		í	£	⊥	⊥	⊥	■	∞	·
D		GS	-	=	M	]	m	)	í	¥	í	⊥	—	■	φ	?
E			.	>	N	·	n	~	λ	R	<	⊥	⊥	■	ε	■
F			/	?	O	—	o	SP	λ	f	>	⊥	⊥	■	∩	SP

## 9.2 International Character Code Table

	Country	23	24	40	5B	5C	5D	5E	60	7B	7C	7D	7E
0	U. S. A.	#	\$	@	[	\	]	^	`	(		)	~
1	France	#	\$	à	·	ç	§	^	`	é	ù	è	-
2	Germany	#	\$	§	λ	0	0	^	`	a	o	u	ü
3	U. K.	£	\$	@	[	\	]	^	`	(		)	~
4	Denmark I	#	\$	@	Æ	Ø	λ	^	`	æ	ø	å	~
5	Sweden	#	¤	é	λ	0	λ	0	é	a	o	a	ü
6	Italy	#	\$	@	·	\	é	^	ù	a	ó	è	ì
7	Spain	R	\$	@	i	ñ	¿	^	`	~	n	]	~
8	Japan	#	\$	@	[	¥	]	^	`	(		)	~
9	Norway	#	¤	é	Æ	Ø	λ	0	é	æ	ø	å	ü
10	Denmark II	#	\$	é	Æ	Ø	λ	0	é	æ	ø	å	ü

# Appendix 1. Block Diagram

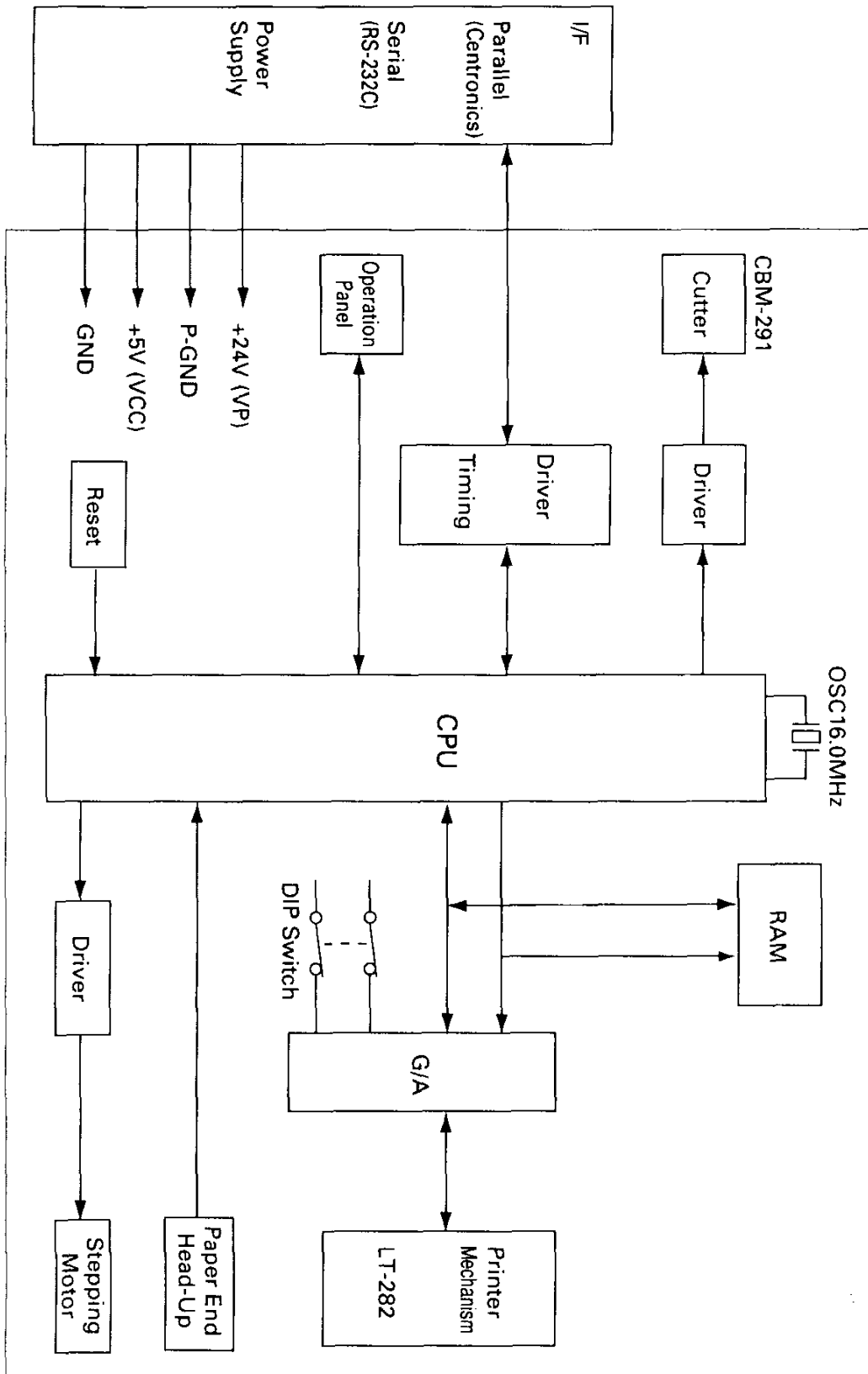



## Appendix 2. Outer Appearance

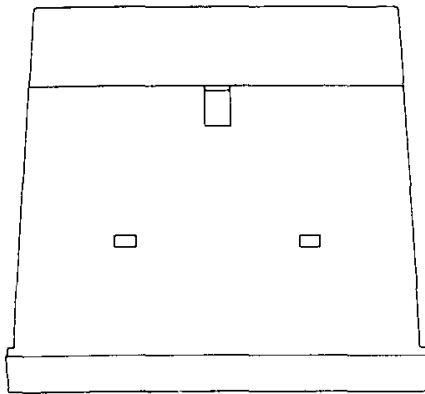

Installing space diameter

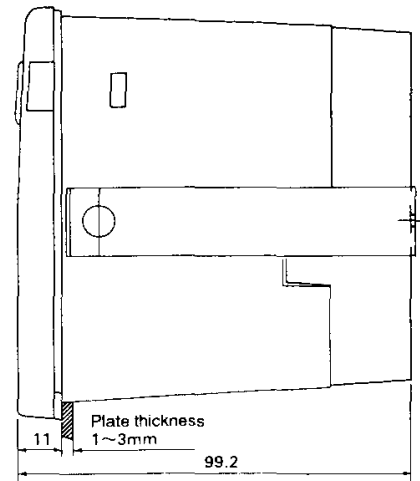
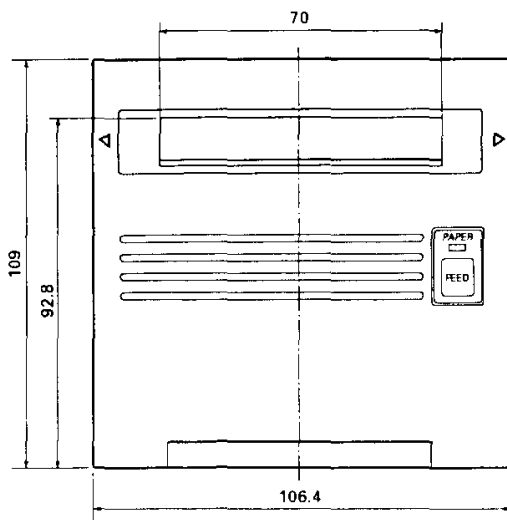
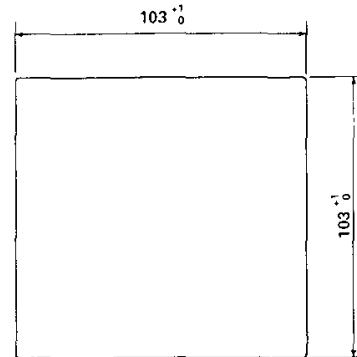

## Free Manuals Download Website

<http://myh66.com>

<http://usermanuals.us>

<http://www.somanuals.com>

<http://www.4manuals.cc>

<http://www.manual-lib.com>

<http://www.404manual.com>

<http://www.luxmanual.com>

<http://aubethermostatmanual.com>

Golf course search by state

<http://golfingnear.com>

Email search by domain

<http://emailbydomain.com>

Auto manuals search

<http://auto.somanuals.com>

TV manuals search

<http://tv.somanuals.com>