

CITIZEN

User's Manual

LINE THERMAL PRINTER

MODEL **CBM-230/231**

Japan CBM Corporation
Information Systems Div.

1996.08.02(10-DCL)15

Declaration of Conformity

Manufacturer's Name : Japan CBM Corporation
 Manufacturer's Address : 1-1-7, Okubo, Shinjuku-ku, Tokyo
 169, Japan

Declare the Product

Product Name Thermal Printer
 Model Number (s) CBM230 Series
 (CBM230R,CBM230P,CBM231R, BM231P
 (S.NO.95Y0001 -)

Conform to the following Standards

LVD	: EN60950	:1992+A1+A2:1993
EMC	: EN55022	:1994 Class A
	: EN61000-3-2	:1995
	: EN50082-1	:1992
	: IEC801-2	:1991 4KV CD, 8KV AD
	: IEC801-3	:1984 3V/m, 27MHz-500MHz
	: IEC801-4	:1988 0.5KV Signal Line 1KV AC mains

Supplementary Information

"The product complies with the requirements of the Low Voltage Directive 73/23/EEC,
 93/68/EEC and the EMC Directive 89/336EEC, 92/31/EEC, 93/68EEC"

Signature

Place Tokyo, Japan

Date November, 1995



Full Name : Koji Tanabe

Position : General Manager

R & D Department

Europe Contact :

Europe Liaison Office
 Kuruisweg 805, Holland Office Center Building
 3-2132 NG Hoofddorp, the Netherlands

Warning

This is a Class A products. In a domestic environment this product may cause radio interference in which case the user may be required to take adequate measures.

This declaration is applied only for 230V model.

IMPORTANT SAFETY INSTRUCTIONS

- Read all of these instructions and save them for later reference.
- Follow all warnings and instructions marked on the product.
- Unplug this product from the wall outlet before cleaning. Do not use liquid or aerosol cleaners. Use a damp cloth for cleaning.
- Do not use this product near water.
- Do not place this product on an unstable cart, stand or table. The product may fall, causing serious damage to the product.
- Slots and openings on the cabinet and the back or bottom are provided for ventilation. To ensure reliable operation of the product and to protect it from overheating, do not block or cover these openings. The openings should never be blocked by placing the product on a bed, sofa, rug or other similar surface.
This product should never be placed near or over a radiator or heat register.
This product should not be placed in a built-in installation unless proper ventilation is provided.
- This product should be operated from the type of power source indicated on the marking label. If you're not sure of the type of power available, consult your dealer or local power company.
- Do not allow anything to rest on the power cord. Do not locate this product where the cord will be walked on.
- In an extension cord is used with this product, make sure that the total of the ampere ratings on the products plugged into the extension cord do not exceed the extension cord ampere rating.
Also, make sure that the total of all products plugged into the wall outlet does not exceed 15 amperes.
- Never push objects of any kind into this product through cabinet slots as they may touch dangerous voltage points or short out parts that could result in a risk of fire or electric shock. Never spill liquid of any kind on the product.
- Except as explained elsewhere in this manual, don't attempt to service this product yourself. Opening and removing those covers that are marked "Do Not Remove" may expose you to dangerous voltage points or other risks. Refer all servicing on those compartments to service personnel.
- Unplug this product from the wall outlet and refer servicing to qualified service personnel under the following conditions:
 - A. When the power cord or plug is damaged or frayed
 - B. If liquid has been spilled into the product.
 - C. If the product has been exposed to rain or water.
 - D. If the product does not operate normally when the operating instructions are followed. Adjust only those controls that are covered by the operating instructions since improper adjustment of other controls may result in damage and will often require extensive work by a qualified technician to restore the product to normal operation.
 - E. If the product has been dropped the cabinet has been damaged.
 - F. If the product exhibits a distinct change in performance, indicating a need for service.

IMPORTANT: This equipment generates, uses, and can radiate radio frequency energy and if not installed and used in accordance with the instruction manual, may cause interference to radio communications. It has been tested and found to comply with the limits for a Class A computing device pursuant to Subpart J of Part 15 of FCC Rules, which are designed to provide reasonable protection against such interference when operated in a commercial environment. Operation of this equipment in a residential area is likely to cause interference, in which case the user at his own expense will be required to take whatever measures may be necessary to correct the interference.

CAUTION: Use shielded cable for this equipment.

For Uses in Canada

This digital apparatus does not exceed the class A limits for radio noise emissions from digital, apparatus, as set out in the radio interface regulations of the Canadian department of communications.

CONTENTS

1 GENERAL DESCRIPTION	6
1.1 Features	6
1.2 Precautions for Installation	6
2 BASIC SPECIFICATIONS	7
2.1 Model Classification	7
2.2 Specifications List	8
2.3 Specifications for Printing Paper	9
2.3.1 Specified Paper	9
2.3.2 Printing Position	9
2.3.3 Head and Cutter Positional Relations.....	9
3 APPEARANCE AND COMPONENT PARTS.....	10
4 OPERATION.....	11
4.1 Connecting the Interface Cable.....	11
4.2 Connecting the Drawer Kick Connector.....	12
4.3 Inserting the Paper Roll	13
4.4 Operation Panel	17
4.5 Opening the Auto Cutter(CBM-231)	18
5 SETTING OF DIP SWITCHES.....	19
6 PARALLEL INTERFACE.....	22
6.1 Specifications	22
6.2 Connector's Pin Configuration.....	22
6.3 Input / Output Signals.....	23
6.3.1 Input / Output Signals.....	23
6.3.2 Electrical Characteristics.....	24
6.3.3 Timing Chart	25
6.3.4 Data Receiving Control.....	25
6.3.5 Buffering	25
7 SERIAL INTERFACE.....	26
7.1 Specifications	26
7.2 Connector's Pin Configuration.....	27
7.3 Input / Output Signals.....	28
7.3.1 Input / Output Signals.....	28
7.3.2 Data Configuration	29
7.3.3 Error Detection	29
7.3.4 Data Receiving Control.....	30
7.3.5 Buffering	30
7.3.6 Electrical Characteristics.....	31
8 DRAWER KICK CONNECTOR.....	32
8.1 Specifications	32
8.2 Connector's Pin Configuration.....	32
8.3 Drive Circuit	32
9 PRINT CONTROL FUNCTION	33
9.1 Control Codes List.....	33
9.2 Input Data Format	34
10 CHARACTER CODE TABLE.....	54
10.1 International	54
10.2 International Character Code Table.....	55
Appendix 1. Precaution and Maintenance	56
Appendix 2. External Dimensions	57
Appendix 3. Block Diagram.....	59

1 GENERAL DESCRIPTION

This is a small line thermal printer developed to be used for various data communication terminals such as POS terminals, kitchen printers.

With its abundant features, it can be widely used for various types of applications.
Read this manual thoroughly prior to using the printer to understand its contents.

1.1 Features

1. Compact, light-weight, and small installation area required
2. High speed and low noise due to line thermal printing
3. High reliability due to long-life printing head and simple mechanism
4. Input buffer incorporated
5. Capable of printing a bar codes (exclusive command)
6. Drawer kickout interface incorporated
7. Equipped with an auto cutter (CBM-231)
8. User-Defined character registration function(95 characters)
9. Easy handling due to incorporated power supply

1.2 Precautions for Installation

1. Upon unpacking the printer, make sure that the following parts are contained in the package.

Printer main body	1 unit
Sample paper roll	1 roll
Instruction manual	1 copy
2. Install the printer on a flat and stable desk or table.
3. Do not install the printer near a heater or in the direct sunshine.
4. Do not use the printer in a high-temperature, high-humidity, or contaminated environment.
5. Prepare a separate AC power supply from other equipment which causes noises.
6. Connect only a specified solenoid to the drawer kick connector.
7. When transporting or not using the printer for a long period of time, leave the printing head kept up.

2 BASIC SPECIFICATIONS

2.1 Model Classification

The model is classified by the following designation method.

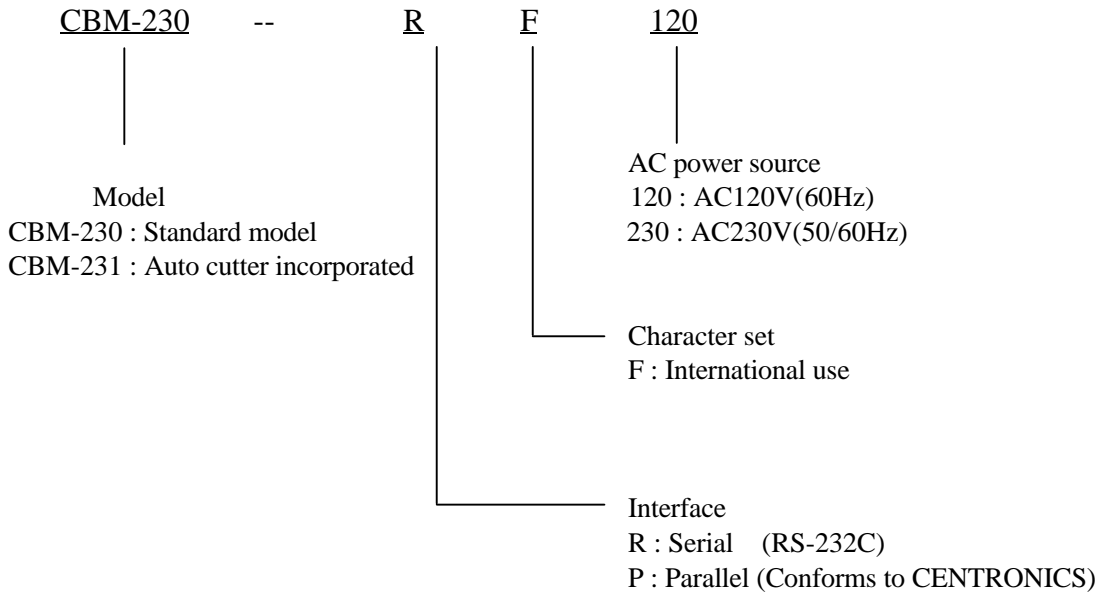

2.2 Specifications List

Item	Description
Printing system	Line thermal dot printing system
Print width	72 mm/576 dots
Dot density	8 dots / mm (Horizontal, Vertical)
Printing speed	62.5 mm/sec. (at Max. speed) (500-dot Line / sec.)
No. of columns	48 columns (12 x 24, Font A) *(42 columns) 64 columns (9 x 17, Font B) *(56 columns)
Character size	1.25 mm x 3.00 mm (12 x 24, Font A) 0.88 mm x 2.13 mm (9 x 17, Font B)
Character type	Alphanumeric, International characters
Bar code type	UPC-A/E, JAN(EAN) 13 columns/18 columns, ITF CODE 39, CODE 128, CODABAR
Line pitch	1/6 inch (approx. 4.23mm) (can be selected by Command) Min. 1/203 inch
Paper	Thermal roll paper 80 mm x Ø83 mm (Refer to Specifications for Print Paper)
Interface	Serial (RS-232C), Parallel (Conforms to Centronics.)
Input buffer	72 byte / 4 K byte (Can be selected with the Dip switch)
Power supply voltage	120 V AC \pm 10 %, 60 Hz 230 V AC \pm 10 %, 50 / 60 Hz
Power consumption	100W
Weight	1.70 kg (CBM-230), 1.85 kg (CBM-231)
External dimensions (main body)	145 (W) x 216 (D) x 150 (H)
Operating temperature/humidity	5 - 40 °C
Storage temperature/humidity	-20 - 60 °C
Reliability	Print head's life : Pulse resistance 50 million pulses Wear resistance 30 Km (Printing ratio 12.5%, normal temperature, normal humidity, recommended paper) Auto cutter's life : 300,000 cut (Normal temperature, normal humidity, recommended paper)

* Special ROM only

2.3 Specifications for Printing Paper

2.3.1 Specified Paper

Type	: Thermal paper
Paper width	: 80+0 or -1 mm
Paper thickness	: 65 ± 5 Micro m
Roll diameter	: Ø83mm or less
Print surface	: Outside of the roll(surface)
Recommended paper	: TF50KS-E2C made by Nihon Paper Mill. or other equivalent
Core	: Ø12 mm (inner diameter), Ø18 mm (outer diameter)

[Caution] Do not paste the paper to the core.

2.3.2 Printing Position

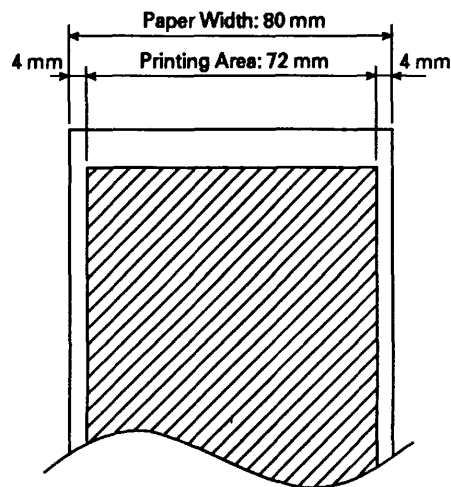

2.3.3 Head and Cutter Positional Relations

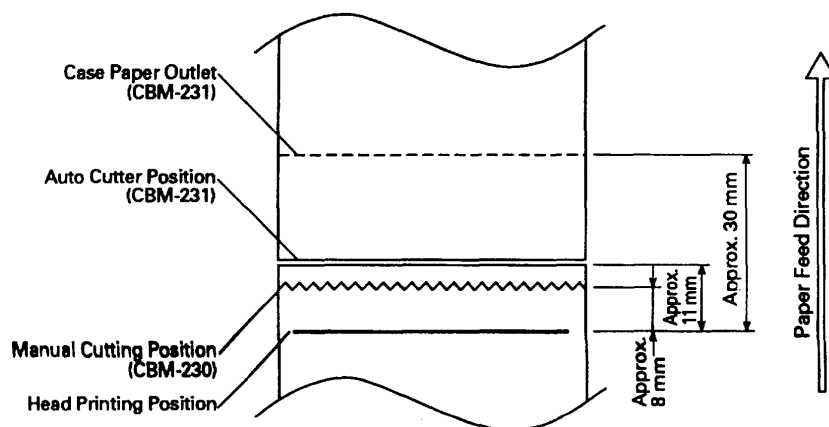

3 APPEARANCE AND COMPONENT PARTS

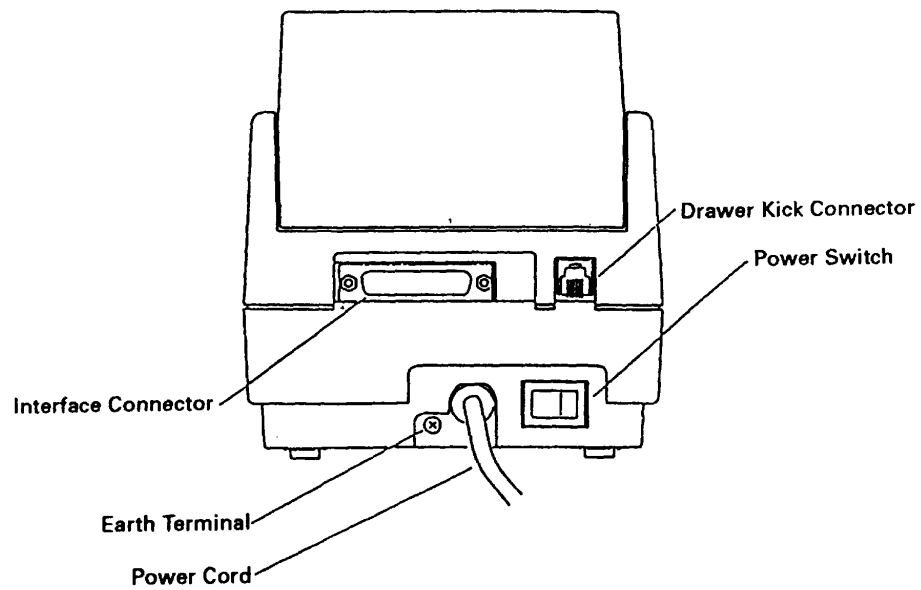
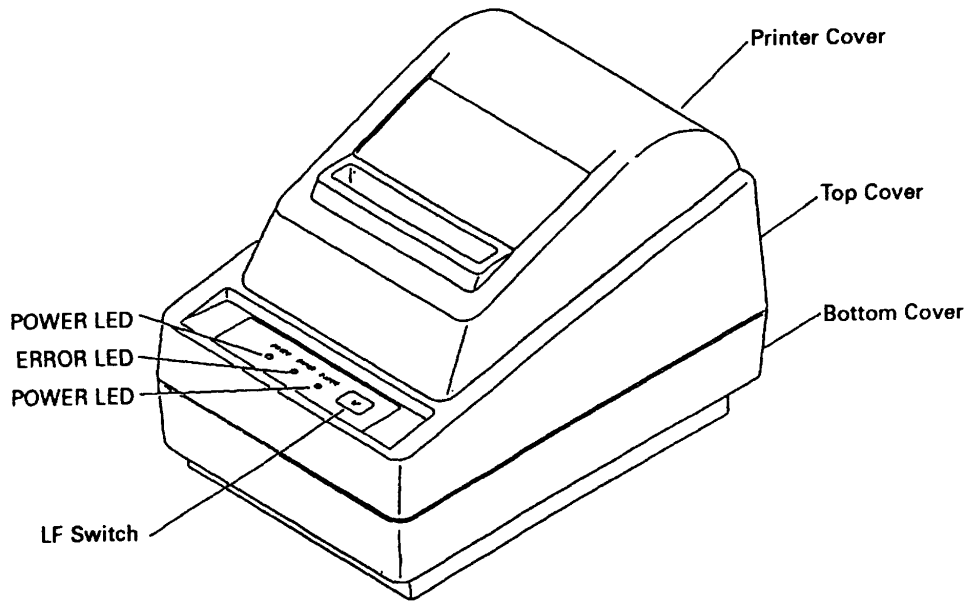

4 OPERATION

4.1 Connecting the Interface Cable

1. Turn off the power.
2. Confirm the vertical direction of a cable terminal and connect it to the interface connector.
3. Fix the cable terminal.
 - Serial interface : Tighten screws to fix.
 - Parallel interface : Turn a fixture in an arrow direction to fix.
4. Connect the cable to the computer.

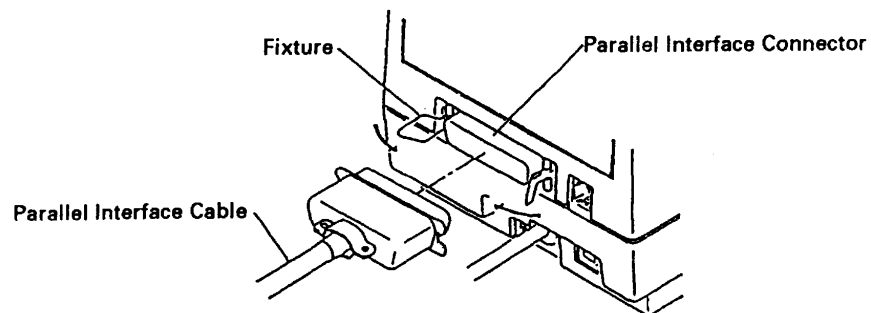
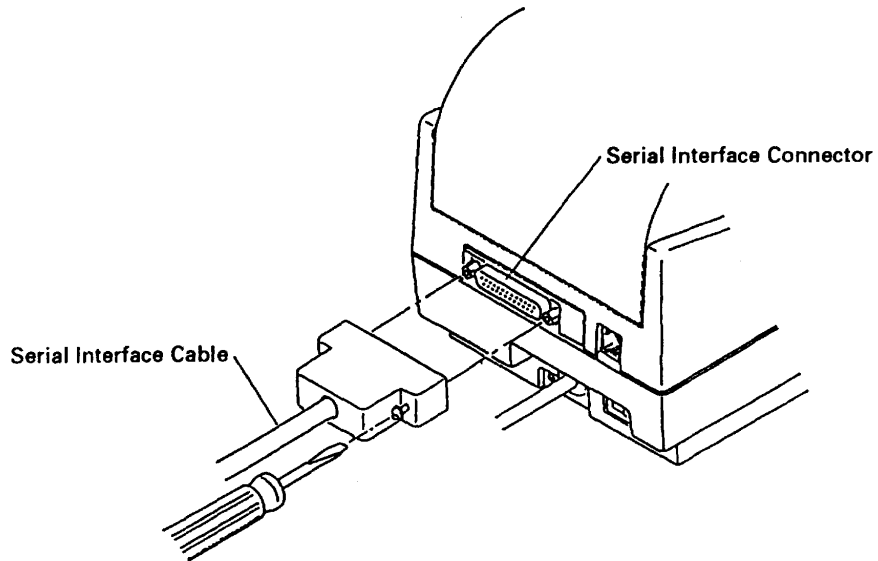

4.2 Connecting the Drawer Kick Connector

1. Turn off the power.
2. Confirm the vertical direction of a drawer kick cable connector and insert it into the drawer kick connector on the back of the printer.
3. Using a screw, fix a drawer's earthing conductor to the earth terminal of the printer.

[Caution] Connect only a specified drawer(solenoid) to the drawer kick connector.

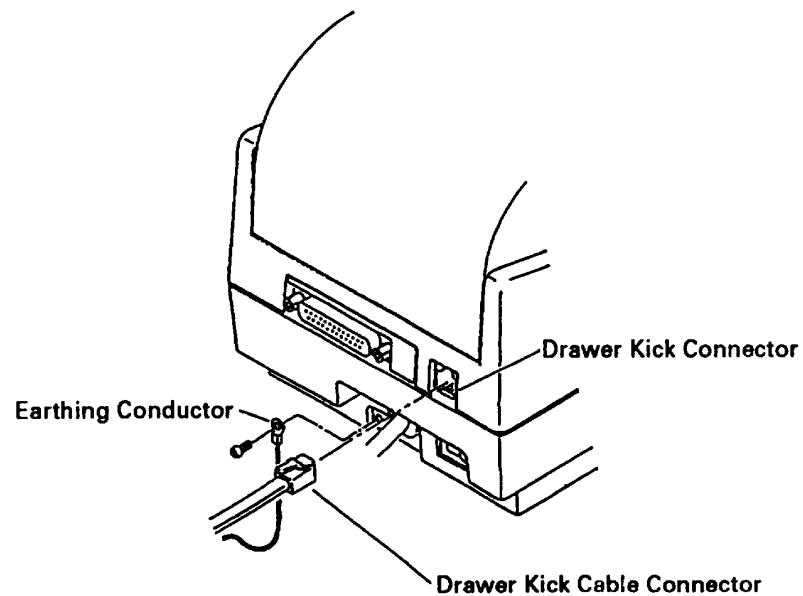

4.3 Inserting the Paper Roll

[Caution] Be sure to use a specified paper roll.

1. Open the printer cover.
2. Shift the head-up lever in an arrow direction to move up the printing head.

[Caution] When setting the paper roll, you do not have to open the auto cutter. (CBM-231)

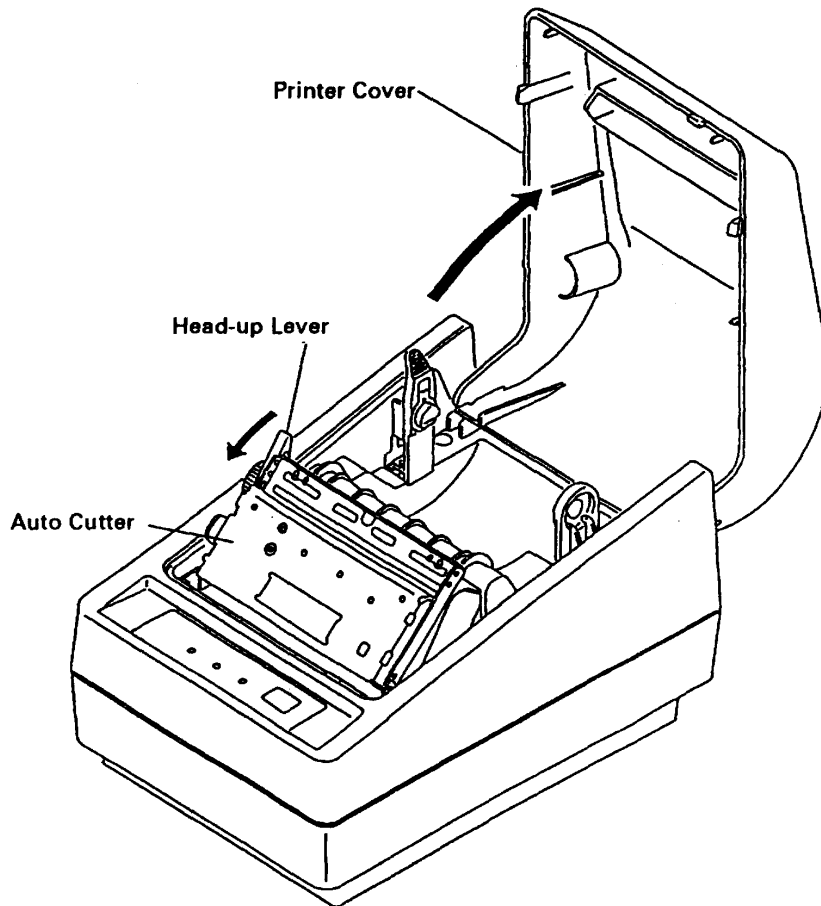

CBM-231

3. Using the scissors, cut the end of the paper at a right angle.
[Caution] Do not insert the paper with its end fluffed or bent.

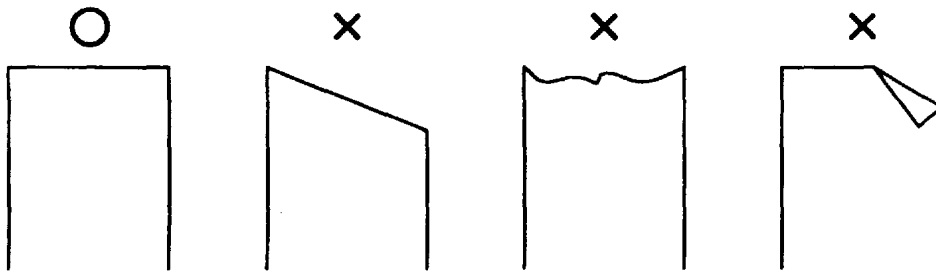

4. Confirm the winding direction of the paper roll. Opening the paper holder in the direction of the arrow, set the paper and hold the core center properly.
[Caution] Make sure that the paper roll rotates smoothly without tilting the paper.

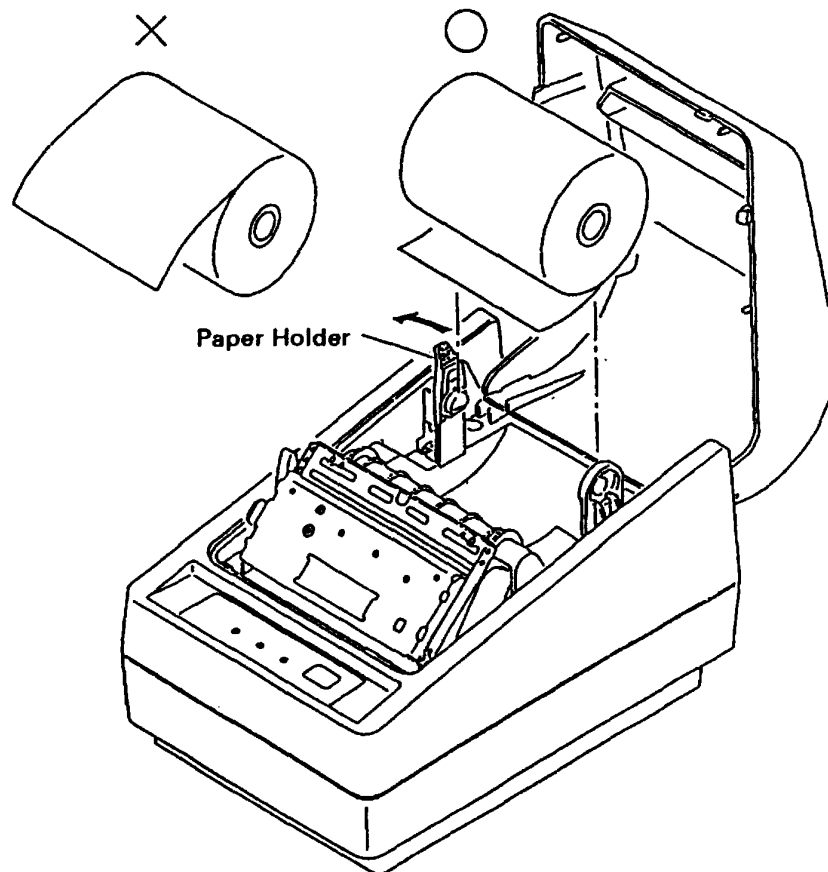

5. Insert the end of the paper into the paper inlet, turn the paper feed knob in the direction of the arrow to feed out the paper about 5 cm from the paper outlet of the auto cutter or nose of the manual cutter. (The figure below shows the CBM-231).
[Caution] Do not turn the paper feed knob when the printing head is in its down position.

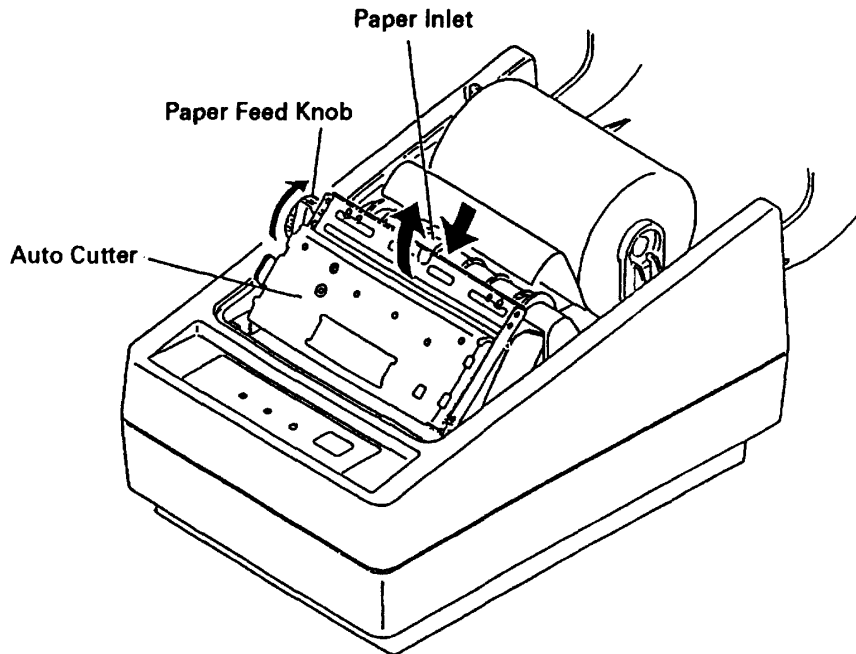

6. When the paper is tilting, correct it and move the printing head down.

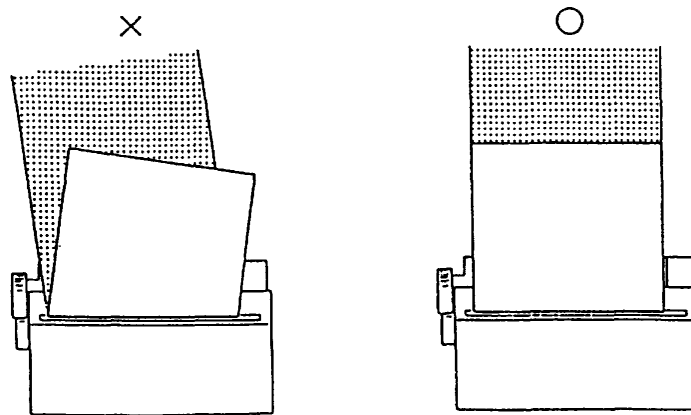

- Cut off the surplus paper at the edge of the paper outlet of the auto cutter or blade of the manual cutter.

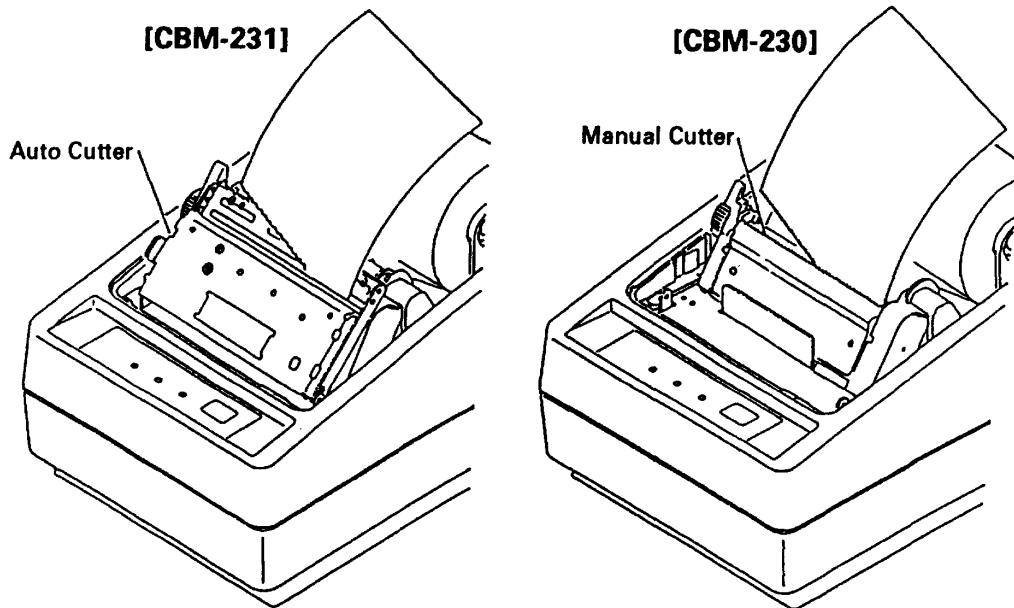

- Close the printer cover. You are finished with setting of the paper roll.
[Caution] Do not open the printer cover during printing.
- When removing the remaining paper upon its replacement with new one, pull it out straight with the printing head kept up.
- When using the auto loading function, follow the procedure below.
 - Change the setting of the DIP switch to the auto loading mode. (Turn on DS1-3)
 - Move the printing head up.
 - Insert the end of the paper straight into the paper inlet of the printer and move down the printing head. The paper is automatically pulled in by a constant amount.
 - Close the printer cover to finish setting of the paper roll.
[Caution] When the paper is tilting, move up the printing head and correct it manually.

4.4 Operation Panel

1. POWER LED(green)

Illuminated when the power is supplied.

2. ERROR LED(red)

Indicates different errors, depending on the illuminated or blinking condition.

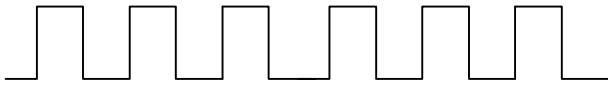
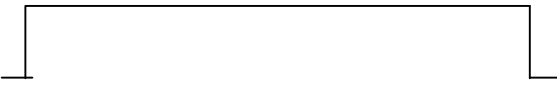
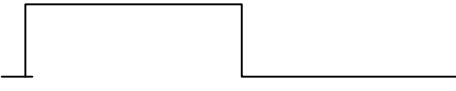
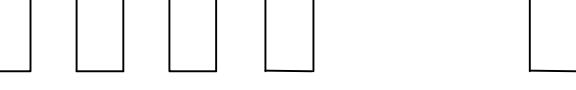
ERROR DETAIL	DISPLAY PATTERN	RESETTING METHOD
Printer cover open	Illuminated	Close the cover
Head Up	Illuminated	Move down the head
Memory check		Disabled
Head overheat		Automatically reset by temperature drop
Macro execution wait		Press the LF switch
Cutter motor lock		Eliminate paper jam and press LF switch

3 PAPER LED(red)

Near end enabled : Illuminated when the paper is near its end (Stops after printing the set length)

Near end disabled : Illuminated when the paper is at its end (Stops printing)

[Caution] Use the DIP switch to enable or disable the near end detecting function.

4 LF switch

Pressing this switch for a short time feeds the paper by one line. Holding it down feeds the paper continuously.

In case of macro execution wait, pressing the LF switch executes it.

[Caution] Depending on a selection of the DIP switch, the paper can be fed when the cover is opened.

5 LF switch and power switch

Self-printing is performed by turning on the power switch with the LF switch held down.

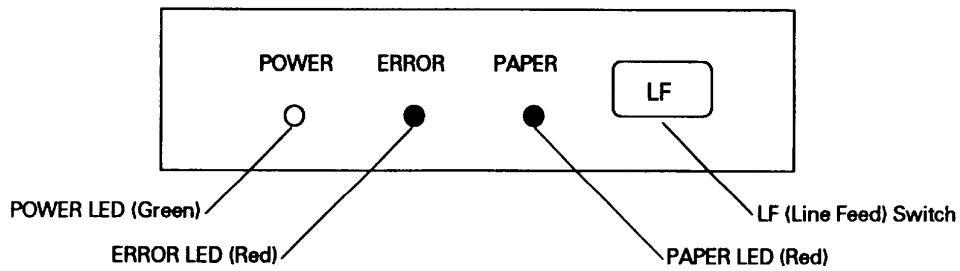

4.5 Opening the Auto Cutter(CBM-231)

When the paper is jamming or when you open the auto cutter in order to clean the head, raise the auto cutter, pulling the cutter lock lever in the direction of the arrow.

[Caution] Immediately after printing, the printing head and motor have a high temperature.

Never touch the printing head and motor when you open the auto cutter.

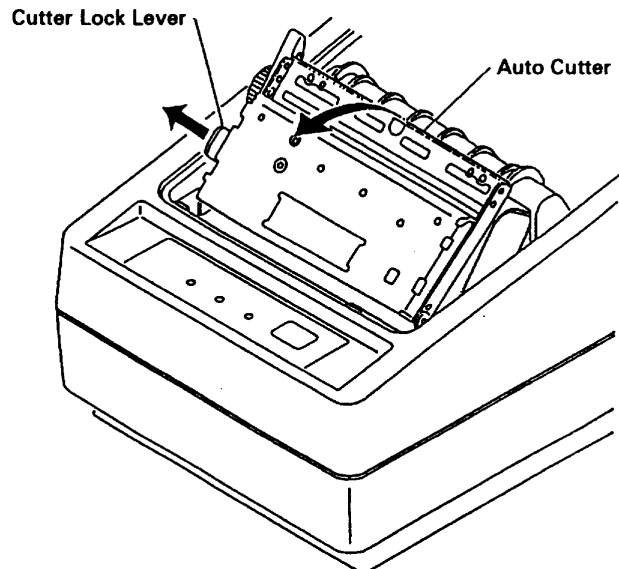

5 SETTING OF DIP SWITCHES

The DIP switches are located in the position shown in the figure below. Unscrew and remove the DIP switch cover.
 [Caution] Turn off the power to set the DIP switch.

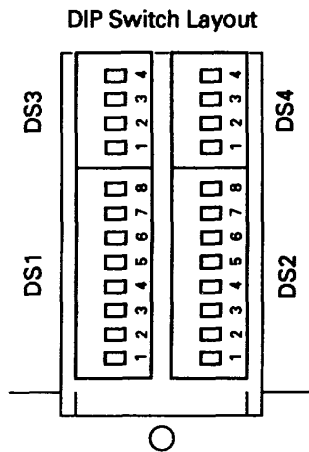
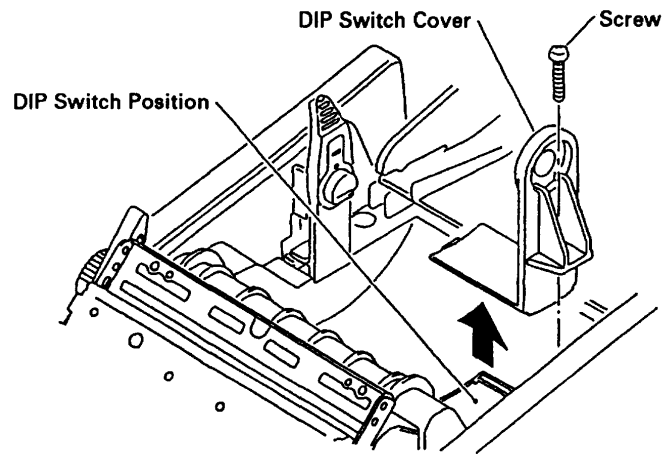

DS1	FUNCTION	ON	OFF	FACTORY SETTING
-1	Paper cutter	Equipped	Not Equipped	*
-2	Cover open	Disabled	Enabled	OFF
-3	Auto loading	Enabled	Disabled	OFF
-4	Input buffer	72 bytes	4K bytes	OFF
-5	Paper near end	Disabled	Enabled	OFF
-6	Paper near end remainder 1	Refer to the table below		OFF
-7	Paper near end remainder 2			OFF
-8	CR switching	LF activated	Ignored	OFF

DS2	FUNCTION	ON	OFF	FACTORY SETTING
-1	Print density	Refer to the table below		ON
-2	Print density			OFF
-3	International character		International	OFF
-4	Unused			OFF
-5	International character	Refer to the table below		OFF
-6	International character			OFF
-7	International character			OFF
-8	International character			OFF

DS3		ON	OFF	FACTORY SETTING
-1	Bit length	7 bits	8 bits	OFF
-2	Parity	Equipped	Not equipped	OFF
-3	Odd / even	Even	Odd	OFF
-4	DTR / XON-XOFF	XON-XOFF	DTR / DSR	OFF

DS4		ON	OFF	FACTORY SETTING
-1	Baud rate	Refer to the table below		OFF
-2	Baud rate			ON
-3	Baud rate			ON
-4	Unused			OFF

The Switch segment marked * are set depending on each models.
 The DIP switches DS3 and DS4 are only for the serial interface.

Remaining printable Length	0 cm	50 cm	1 m	2 m
DS1-6	OFF	ON	OFF	ON
7	OFF	OFF	ON	ON

Print density	Light	Standard	Dark	darker
DS-1	OFF	ON	OFF	ON
-2	OFF	OFF	ON	ON

INTERNATIONAL	U.S.A.	FRANCE	GERMANY	U.K.	DENMARK 1	SWEDEN	ITALY	SPAIN	JAPN	NORWAY	DENMARK2
DS1-6	OFF	ON	OFF	ON	OFF	ON	OFF	ON	OFF	OFF	OFF
DS1-6	OFF	OFF	ON	ON	OFF	OFF	ON	ON	OFF	OFF	ON
-7	OFF	OFF	OFF	OFF	ON	ON	ON	ON	OFF	ON	OFF
-8	OFF	OFF	OFF	OFF	OFF	OFF	OFF	OFF	ON	ON	ON

BAUD RATE	150	300	600	1200	2400	4800	9600	19200
DS4-1	OFF	ON	OFF	ON	OFF	ON	OFF	ON
-2	OFF	OFF	ON	ON	OFF	OFF	ON	ON
-3	OFF	OFF	OFF	OFF	ON	ON	ON	ON

6 PARALLEL INTERFACE

6.1 Specifications

- Data input method : 8-bit parallel(DATA 1-8)
- Control signal : ACK, BUSY, STB, FAULT, PE, RESET
- Applicable connectors : Printer side : 57LE-40360(equivalent to amphenol)
Cable side : 57-30360(equivalent to amphenol)

6.2 Connector's Pin Configuration

No.	SIGNAL NAME	No.	SIGNAL NAME
1	STB	19	TWISTED PAIR GND
2	DATA 1	20	
3	DATA 2	21	
4	DATA 3	22	
5	DATA 4	23	
6	DATA 5	24	
7	DATA 6	25	

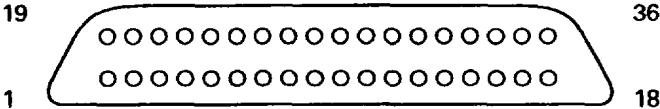

7 DATA 6 25

CITIZEN 22

7 DATA 6 25

6.3 Input / Output Signals

6.3.1 Input / Output Signals

(1) Input signals to the printer

- DATA : This is an 8-bit parallel signal (Positive logic)
- STB : This is a strobe signal to read in 8-bit data (Negative logic)
- RESET : This signal resets the entire printer (Negative logic) 1 ms or more

(2) Output signals from the printer

- ACK : This is an 8-bit data request signal. Pulse signal output at the end of the BUSY signal (Negative logic)
- BUSY : This signal indicates the BUSY state of the printer. Enter new data when it is at LOW. (Positive logic)
- FAULT : This signal is set to low when the printer has an alarm.
When this is done, all control circuits in the printer stop. (Negative logic)
- PE : This signal is output when the printing paper has run out or is running out.
(Positive logic)
- Drawer switch output : This signal is set to HIGH when the switch is opened, and to LOW when shorted.

(3) Power signals

- +5VDC : This is a 5 V output pulled up at a 3.3 k Ohm resistor.
- GND : This is a common ground on the circuits.

6.3.2 Electrical Characteristics

(1) Input signal level

All input signals are at the TTL level.

"HIGH" level: 2.0 V at minimum

"LOW" level : 0.8 V at maximum

(2) Output signal level

All output signals are at the TTL level.

"HIGH" level: 2.4 V at minimum

"LOW" level : 0.4 V at maximum

(3) Input/output conditions

All input signals are pulled up at 3.3 k Ohm.

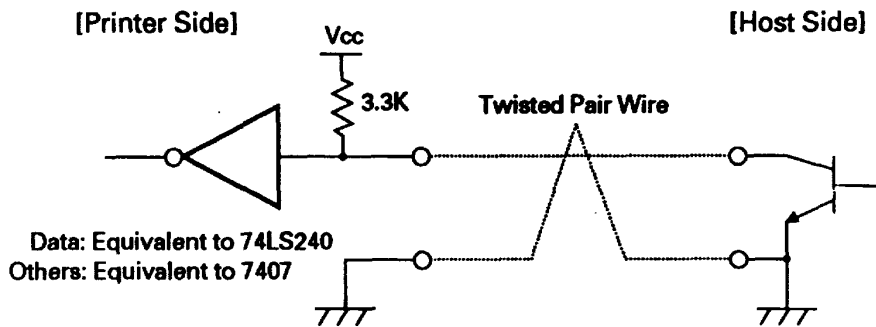

All output signals are pulled up at 3.3 k Ohm.

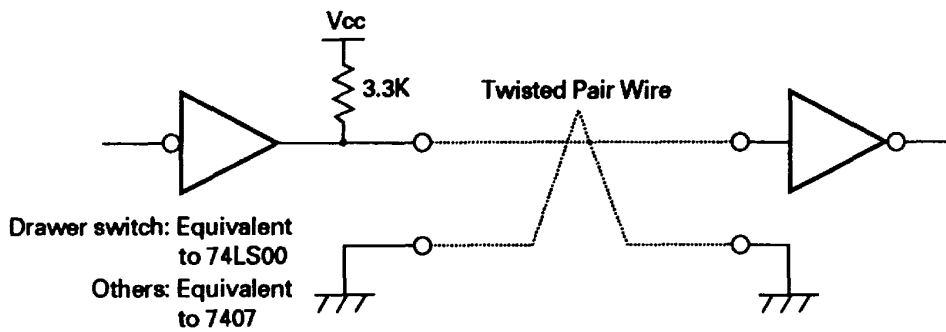

6.3.3 Timing Chart

(1) Data input and printing timing

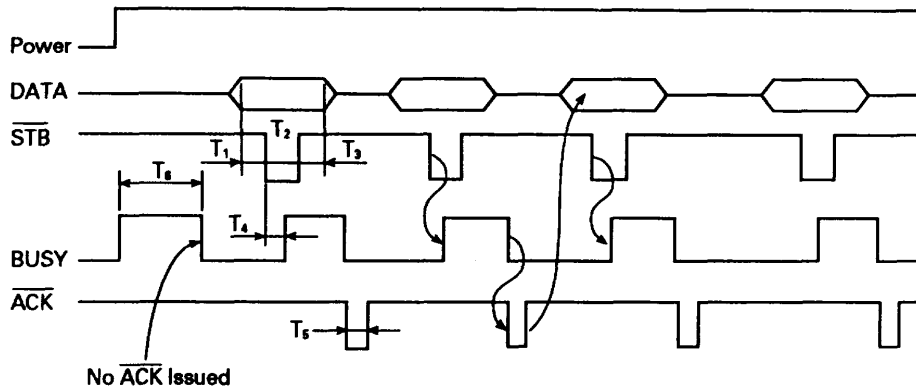

T1, T2, T3	0.5 μ s MIN
T4	270 ns MAX
T5	2.3 μ s TYP
T6	500 ms MIN (at power-on)

6.3.4 Data Receiving Control

When the BUSY signal is at LOW, the data from the host side can be received, but when at HIGH, it cannot be received.

6.3.5 Buffering

A size of the input buffer can be selected by setting the DIP switch segment DS1-4.

When a 4KB buffer is selected, the host side is immediately free because a large amount of data can be buffered.

7 SERIAL INTERFACE

7.1 Specifications

- (1) Synchronizing system : Asynchronous
- (2) Baud rate : 150, 300, 600, 1,200, 2,400, 4,800, 9,600, 19,200 bps (Selected by the user)
- (3) Word Length
 - Start bit : 1 bit
 - Data bit : 7 bits or 8 bits (Selected by the user)
 - Parity bit : Odd/even parity or no parity (Selected by the user)
 - Stop bit : 1 bit or more
- (4) Signal polarity
 - RS-232C
 - Mark = Logic "1" (-3 V to -12 V)
 - Space = Logic "0" (+3 V to +12 V)
- (5) Receive data (RD signal)
 - RS-232C
 - Mark = 1
 - Space = 0
- (6) Data receiving control (DTR signal)
 - RS-232C
 - Mark : Data transfer not possible
 - Space : Data transfer possible
- (7) Data transmission control (TD signal)
 - DC1 code(11H) X-ON : Data reception possible
 - DC3 code(13H) X-OFF : Data reception not possible

7.2 Connector's Pin Configuration

No.	SIGNAL NAME	I/O	FUNCTION
1	FG		Frame Grand
7	GND		Signal GND
3	RD	Input	Receiving data
20	DTR	Output	Printer BUSY signal
2	TD	Output	Transmission data
6	DSR	Input	Data set READY

- [Cautions]
1. RS-232C signals are based on the EIA RS-232C.
 2. When no data is being transferred, the receive data should be always maintained in the mark state.

Applicable connectors (D-Sub connectors)

Printer side : 17LE-13250 (Equivalent to DDK)

Cable side : 17JE-23250 (Equivalent to DDK)

7.3 Input / Output Signals

7.3.1 Input / Output Signals

(1) RD

This is a serial receive data signal. When there is a framing error, overrun error, or parity error, that data is printed as "?."

(2) DTR

Write the data or a command when this signal is ready.

If you write while it is busy, the data will be ignored, resulting in an overrun error.

The data can be written into the input buffer even during printing.

A BUSY signal is also issued at power-on, during test printing, in the on-line mode, or upon occurrence of reset.

(3) TD

When the remaining capacity of the input buffer on the printer side comes to 10 bytes(at 72 bytes) or 128 bytes(at 4K bytes) while receiving the data, DC3(13H), a data reception impossible signal, is output.

When the remaining capacity of the input buffer comes to over 20 bytes(at 72 bytes) or

256 bytes(at 4K bytes)DC1(11H), a data reception possible signal is output to the host side.

When transmitting the status information, if DTR/DSR control has been selected, the data will be transmitted after confirming that DSR is a space.

If DTR/DSR control has not been selected, the data will be transmitted, ignoring DSR.

(4) FG

This is a Frame ground.

(5) GND

This is a common ground on the circuits.

7.3.2 Data Configuration

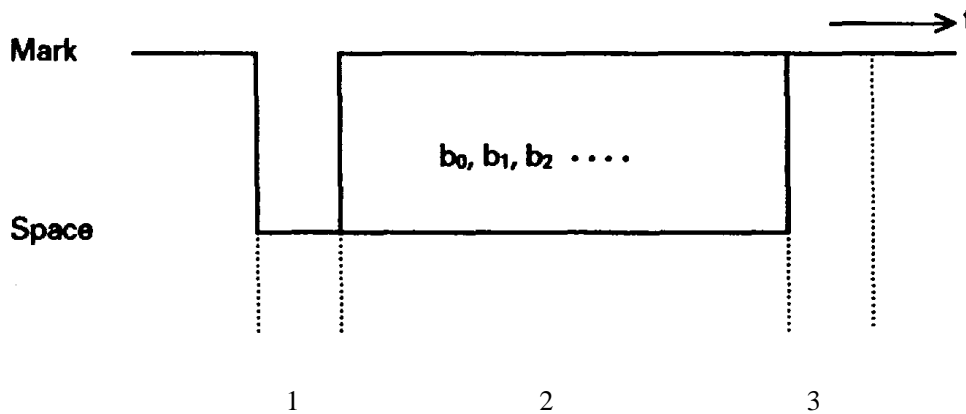

- 1 Start bit
- 2 Data bit(+ parity bit)
- 3 Stop bit(1 or more)

(1) Start bit

When half a bit has passed since a fall edge of a mark to a space, the state of the bit is read in again, and if it is a space, it will be recognized as a start bit.

If it is a mark, it will not be recognized as the start bit. The start bit will be detected again without assuming it to be an error.

(2) Data bit + parity bit

The data bit and parity bit are sampled for one bit worth of time since the time of half the start bit and assume the then state to be the data for the relevant bits.

The bits are arranged in order of bit 0, bit 1, ..., parity bit, starting from the one next to the start bit.

(3) Stop bit

The stop bit is a 1-bit or more mark level. If a space is detected in detecting the stop bit, a framing error will result.

7.3.3 Error Detection

A parity error, framing error, and overrun error are detected. When an error is detected, that data is stored in the buffer as "?."

(1) Framing error

When a space is detected at stop bit detection time, an error result. That data is stored in the buffer as "?."

(2) Parity error

When a parity check has been specified and an error is detected at parity check time, that data is stored in the buffer as "?."

(3) Overrun error

When an overrun error is detected, that data is stored in the buffer as "?."

7.3.4 Data Receiving Control

When DTR/DSR control has been selected, if the DTR signal is at SPACE, the data from the host side can be received, but when at MARK, it cannot be received.

When DTR/DSR control has not been selected, the data from the host side can be received after transmitting XON, but it cannot be received after transmitting XOFF.

7.3.5 Buffering

There are DTR and TD signals as control signals for data transfer to the input buffer.

- (1) DTR signal (Refer to 7.3 1)
- (2) TD signal (Refer to 7.3 1)

7.3.6 Electrical Characteristics

(1) RS-232C circuit
Input (RD,DSR)

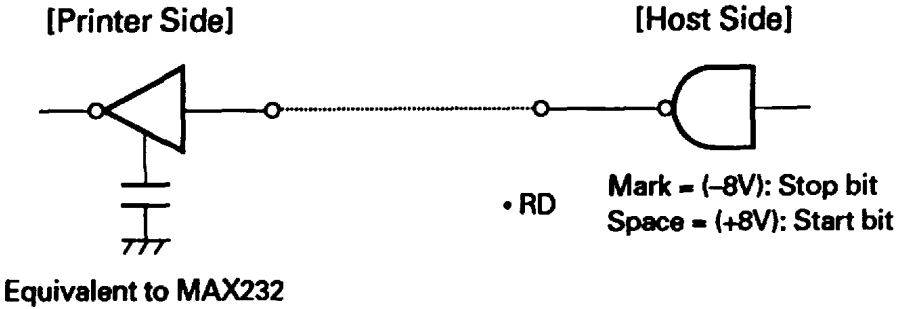

Output (DTR,TD)

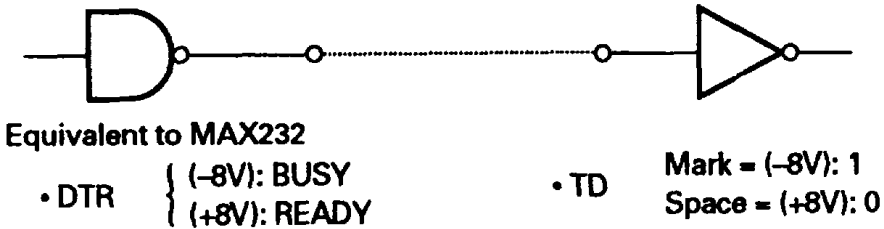

8 DRAWER KICK CONNECTOR

8.1 Specifications

(1) Drawer kick drive signal

The pulses specified by ESC p are output. The state of the switch(+) can be known through the pin 34 of the interface connector when parallel interface is used, and through the ESC u command when the serial interface is used.

(2) Electrical characteristics

- 1) Drive voltage : DC 24 V
- 2) Drive current : 0.8 A at maximum(should be within 510 ms)
- 3) Switch signal : Signal level "L" = 0 to 0.5 V
"H" = 3 to 5 V

8.2 Connector's Pin Configuration

No.	SIGNAL NAME	FUNCTION
1	FG	Frame ground
2	DRAWER 1	Drawer 1 driving signal
3	DRSW	Drawer SW input
4	VDR	Drawer driving power supply
5	DRAWER 2	Drawer 2 driving signal
6	GND	Common ground on the circuits

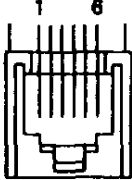

Connector used : TM5RJ3-66(HIROSE)

Applicable connector :Equivalent to TM3P-66P(HIROSE)

[Cautions] 1) No output is allowed during printing.

2) The drawers 1 and 2 cannot be driven at the same time.

3) A solenoid for the drawer should be of 36 Ohm or more.

(See to it that an output current will not exceed 0.8 A.

Be careful not to use a drawer with a current over 0.8A to avoid damage to the printer.)

8.3 Drive Circuit

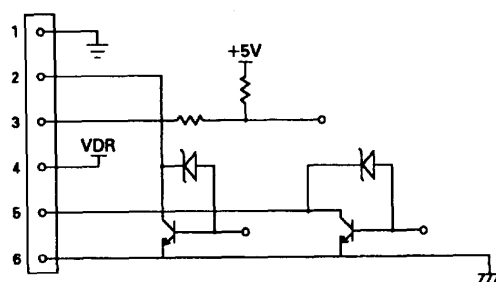

9 PRINT CONTROL FUNCTION

9.1 Control Codes List

	CONTROL CODE	FUNCTION
1	HT	Horizontal tab command
2	CR	Print command
3	LF	Printing and paper feed
4	ESC SP	Setting the right space amount of the character
5	!	Collective specifying printing mode
6	%	Specifying/canceling download character set
7	&	Defining download characters
8	*	Specifying the bit image mode
9	-	Specifying/canceling underline
10	2	Specifying 1/6-inch line feed rate
11	3	Setting line feed rate n/203 inch
12	@	Initializing the Printer
13	D	Setting horizontal tab position
14	E	Specifying/canceling highlighting
15	G	Specifying/canceling double printing
16	J	Printing and feeds paper n/203 inch
17	R	Selecting the international characters
18	c3	Setting of paper end sensor effective for outputting a signal for no paper(Parallel Mode Only)
19	c4	Setting of paper end sensor effective for print stop
20	c5	Enabling/disabling the panel switches
21	d	Printing and feeding the paper by n lines
22	p	Generating the specified pulse(Drawer Kickout)
23	t	Selecting the character code table
24	v	Transmitting the printer status(Serial Mode Only)
25	u	Transmitting the status of peripheral equipment(Serial Mode Only)
26	{	Specifying/canceling the inverted characters
27	V	Specifying/canceling the 90°- right-turned characters
28	\$	Specifying the absolute positions
29	¥	Specifying the relative positions
30	GS k	Printing the bar code
31	w	Selecting the horizontal size (scale factor) of bar code
32	h	Selecting the height of the bar code
33	H	Selecting the printing position of HRI character
34	f	Selecting the font of HRI character
35	*	Defining the download bit image
36	/	Printing the download bit image
37	:	Starting/ending macro definition
38	^	Executing the macro
39	ESC =	Data input control
40	a	Aligning the characters
41	i	Full cut
42	m	Partial cut

9.2 Input Data Format

(1) Horizontal Tab Command (HT)

Code : (09)h

Shifts the printing position to the next horizontal tab position. The horizontal tab position is set by ESC D. Initial setting of the horizontal tab position is in 9th, 17th, 25th, 33rd, 41st columns of FONT A.

(2) Print Command (CR)

Code : [0D]h

1) When DS 1 - 8 is OFF:

This command is ignored.

2) When DS 1 - 8 is ON:

With data held inside the input buffer, printing and line feed are performed.

Without data inside the input buffer, however, no printing is performed.

(3) Printing and Paper Feed Command (LF)

Code : [0A]h

Prints data inside the internal input buffer and feeds lines based on the line feed amount having been set.

(4) Setting the right space amount of the characters (ESC SP)

Code : [1Bh] + [20h] + n

* {0 < n < 20} Data is described in Hex code.

The rightward space amount is set in dot unit (0.165 mm unit). In the initial value, it is n=0.

The rightward space amount in double wide mode is made double of the set volume.

(5) Specifying Collectively the Print Mode (ESC ! n)

Code: [1Bh] + [21h] + n

* {0 < n < FF} The data is described in Hex code.

Printing mode is assigned. Each n bit indicates the following:

BIT	FUNCTION	VALUE	
		0	1
0	Character font	Font A	Font B
1	Undefined		
2	Undefined		
3	Highlighting	Canceled	Specified
4	Double height	Canceled	Specified
5	Double width	Canceled	Specified
6	Undefined		
7	Underline	Canceled	Specified

- With double height and double width being specified simultaneously, double wide and double high characters are consisted.
- An underline is attached to the full character width, which, however, is not attached to the part having been skipped by the horizontal tab. Neither is it attached to 90°-right-turned characters.
- The underline width is as having been specified by ESC -. The initial value is "0".

(6) Specifying/Canceling Download Character Set (ESC % n)

Code: [1B]h + [25]h + n

* {0 < n < FF} Data is described in Hex code.

Specifying/canceling download characters. Download characters and download bit images cannot be defined simultaneously. Further, only the lowest bit (n0) is valid for n. The lowest bit (n0) indicates the following:

- n0= 0: Canceling download character
- n0= 1: Specifying download character

(7) Defining Download Character (ESC & s n m a (D1D2 -Dn)

Code: [1B]h + [26]h + s +n +m +a +Dn

* {s = 02}

{20 (Hex) ≤ n ≤ 7E (Hex)}

{20 (Hex) ≤ m ≤ 7E (Hex)}

{0 < a < 0A (Hex)}

Defines the font of download characters of alphanumeric characters.

- "s" indicates the number of bytes in vertical direction.
- "n" indicates the start character code and "m" indicates the end character code. To define only one character, set n = m.
- Character codes definable includes 95 ASCII codes in total between <20>H-<7E>H.
- "a" indicates the number of dots in horizontal direction for definition.
- Dn is the data to be defined, which indicate a pattern equal to "a" dot in horizontal direction from the left end. The rest of the pattern on the right side is filled with space.
- Download characters thus defined remain valid until redefinition, ESC @ execution, GS * execution, or power OFF is practiced.

Example
For Font A

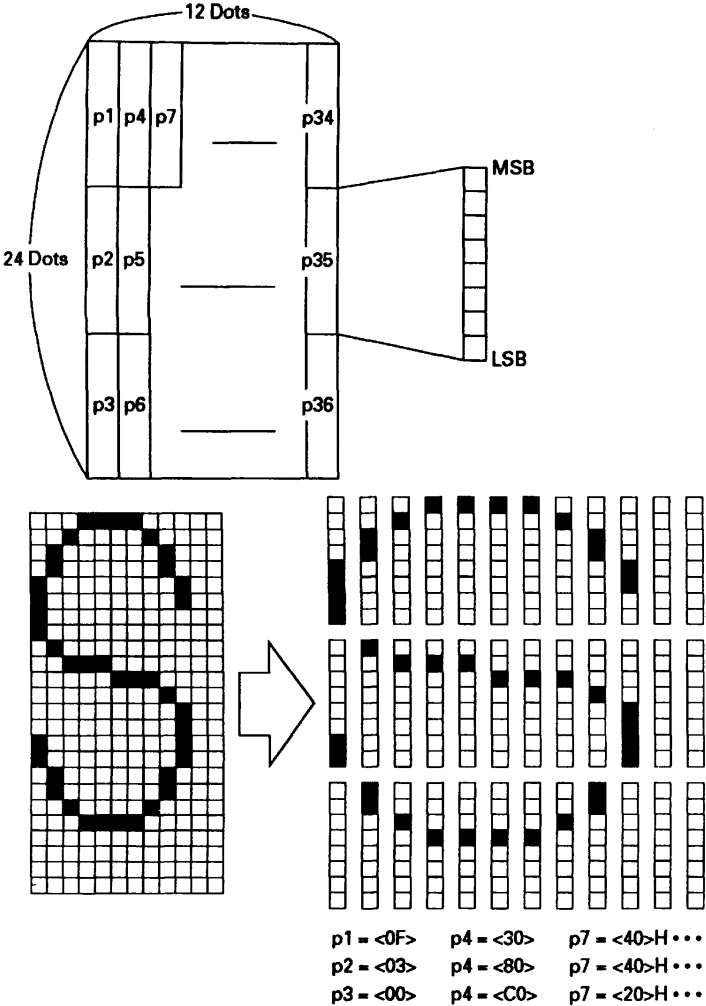

For Font B

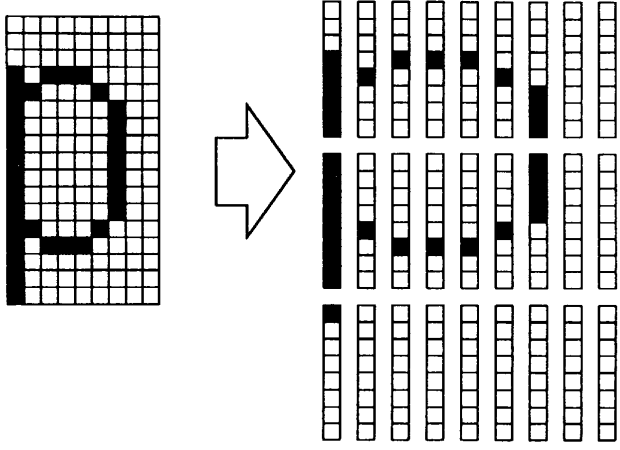
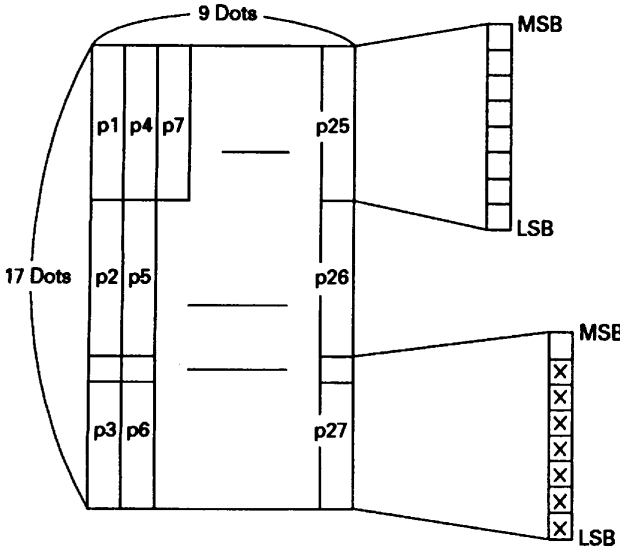

p1 = <1F> p4 = <08>H p7 = <10>H...
 p2 = <FF> p4 = <08>H p7 = <04>H...
 p3 = <80> p4 = <00>H p7 = <00>H...

(8) Specifying the Bit Image Mode (ESC * m n1 n2 D1 -Dn)

Code : [1B]h + [2A]h + m + n1 + n2 + Dn

* {m= bit image mode (See the table below.)}

{0 ≤ n1 ≤ FF}

{0 ≤ n2 ≤ 02} Data is described in Hex code.

According to the bit image mode assigned in m, prints data in the bit image.

- The no. of dots printed is divided by 256, whose quotient is taken as n2 and residual as n1.
- The total no. of dots printed in the bit image is equal to n1 + (256 x n2).
- When bit image data have been input in excess of 1 dot/line (448 dots) position, the excess data are discarded.
- In the bit image data (Dn), the bits subject to printing are taken as "1" and those not as "0".
- The bit image modes are shown as follows:

m(Hex)	MODE	VERTICAL DIRECTION		HORIZONTAL DIRECTION	
		NO. OF DOTS	DOT DENSITY	DOT DENSITY	MAX. NO OF DOTS
0	8-dot single density	8	67 DPI	101 DPI	288
1	8-dot double density	8	67 DPI	203 DPI	576
20	24-dot single density	24	203 DPI	101 DPI	288
21	24-dot double density	24	203 DPI	203 DPI	576

- When the value set in m (bit image mode) are out of conditions, the data following after n1 is processed as printing data.

The relation between bit image data and printing dots are shown below.

8-dot Bit Image

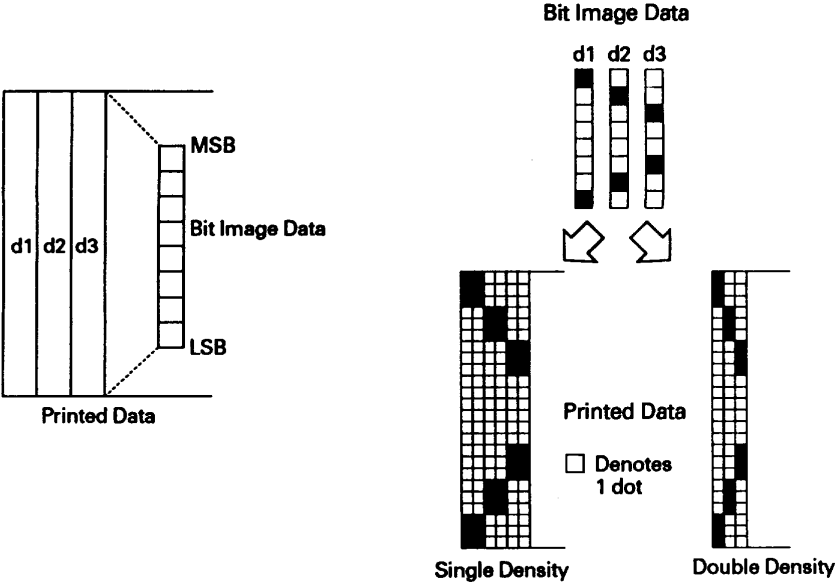

24-dot Bit Image

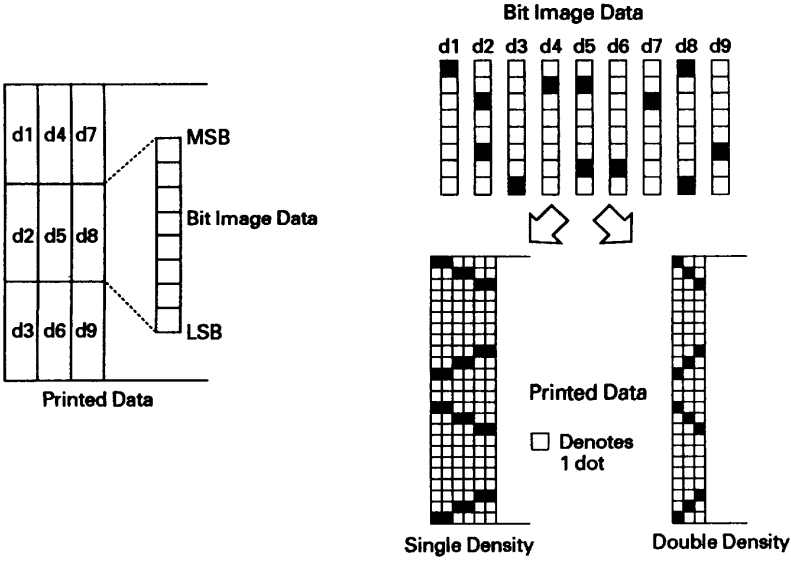

(9) Specifying/ Canceling Underline (ESC - n)

Code: [1B]h + [2D]h + n

* {0 ≤ n ≤ 02} Data is described in Hex code.

Specifying/canceling an underline.

- An underline is attached to the full character width. It is, however, not attached to the part having been horizontal tab command.
- An underline is not attached to a 90 °- right-turned characters.
- An initial value is "1".
- Types of underlines by n value are shown below:

n (Hex)	Type
0	Canceling an underline.
1	Specifying an underline for 1-dot width.
2	Specifying an underline for 2-dot width.

(10) Specifying 1/6 inch line feed rate (ESC 2)

Code : [1B]h + [32]h

The line feed rate per line is specified by 1/6 inch.

(11) Setting line feed rate n/203 inch (ESC 3 n)

Code : [1B]h + [33]h + n

* {0 ≤ n ≤ FF} Data is described in Hex code.

The line feed rate per line is specified by n/156 inch.

- The initial value is n = [22]h

(12) Initializing Printer (ESC @)

Code : [1B]h + [40]h

Clears data stored in the print buffer and brings various settings to the initial state (Default state).

- Data inside the internal input buffer are not cleared.
- Dip switches are read once again.

(13) Setting Horizontal Tab Position (ESC D n NUL)

Code : [1B]h + [44]h + n [00]h

* {0 ≤ n ≤ FF} Data is described in Hex code.

Specifying a horizontal tab position.

- "n" indicates the no. of columns from the beginning to the horizontal tab position. At this time, n= set position - 1 is to be specified.
- The tab position is set at position where it is "character width x n" from the line beginning. The character width, at this time, includes the rightward space amount. In double wide characters, it is made double of the ordinary case.
- Tab positions can be specified are maximum 24. Specifying exceeding this is ignored.
- ESC D NUL clears all the set tab positions. Following clearing, horizontal tab command is ignored.
- Initial value is specified for each eight characters(9.17.25.33.41) of ANK characters.

(14) Specifying/canceling highlighting (ESC E n)

Code : [1B]h + [45]h + n

* {0 ≤ n ≤ FF} Data is described in Hex code.

Specifying/canceling the highlighted characters.

- "n" is valid only for the lowest bit (n0).
- Control by the lowest bit (n0) is shown as follows:

	Type
0	
0	Canceling highlighting.
1	Specifying highlighting.

- This is effective to all characters.
- Dot configuration of a highlighted character includes one extra dot added at its side.

(15) Specifying/canceling Double Printing (ESC G n)

Code : [1B]h + [47]h + n

* {0 ≤ n ≤ FF} Data is described in Hex code.

Specifying/canceling the double printing.

- "n" is valid only for the lowest bit (n0).
- Control by n is shown as follows.

	Type
0	
0	Canceling double printing.
1	Specifying double printing.

- The print result of Double printing and highlight character printing is completely same

(16) Printing and feeding paper n/203 inch (ESC J n)

Code : [1B]h + [4A]h + n

* {0 ≤ n ≤ FF} Data is described in Hex code.

Prints data inside the print buffer and feeds paper by n/156 inch.

- Specified volume does not remain.
- The beginning of the line is to be considered as the next printing start position.

(17) Selecting International Characters (ESC R n)

Code : [1B]h + [52]h + n
 * {0 ≤ n ≤ 0A} Data is described in Hex code.

Selecting international characters.

- Depending on the value of n, following character sets are specified.

n(Hex)	CHARACTER SET
0	U.S.A.
1	France
2	Germany
3	U.K.
4	Denmark 1
5	Sweden
6	Italy
7	Spain
8	Japan
9	Norway
A	Denmark 2

- The initial value of n indicates the character set specified by the dip switch. However, setting is available only through use of this command for "Spain", "Norway", and "Denmark II".

(18) Setting of paper end detector available for output of paper end signal

Code : [1B]h + [63]h + [33]h + n
 * {0 ≤ n ≤ FF} Data is described in Hex code

Specifying the condition of paper end detector to stop printing operation.

- n is valid only for the lowest bit. (n0)
- n bit means the followings.

n0	Condition
0	Paper near end disable (initial value)
1	Paper near end enable

Remarks : This is valid only for parallel interface model.

(19) Setting of paper end detector available for print stop

Code : [1B]h + [63]h + [34]h + n
 * {0 ≤ n ≤ FF} Data is described in Hex code.

Specifying the condition of paper end detector to stop printing operation.

- n is valid only for the lowest bit. (n0)
- An initial value of "n" is specified by the Dip Switch (DS1-5).
- n bit means the followings.

n0	Condition
0	Paper near end disable (initial value)
1	Paper near end enable

(20) Enabling/Disabling Panel Switch (ESC c 5 n)

Code : [1B]h + [63]h + [35]h + n
 * {0 ≤ n ≤ FF} Data is described in Hex code.

Selecting the paper feed switch valid/invalid.

- "n" is valid only in the lowest bit (n0).
- "n" bit means the followings.

	Condition
0	
0	LF switch enabled
1	LF switch disabled

- The initial value of n is "0".

(21) Printing and Feeding the paper by n lines (ESC d n)

Code : [1B]h + [64]h + n
 * {0 ≤ n ≤ FF} Data is described in Hex code.

Prints data inside the buffer and feeds paper by n lines.

- Specified line does not remain.
- The beginning of the line is to be considered as the next printing start position.

(22) Generating specified Pulse (ESC p m n1 n2)

Code : [1B]h + [70]h + m + n + n2
 * {m = connector pin No. (See table below.)}
 {0 ≤ n1 ≤ FF}
 {0 ≤ n2 ≤ FF} Data is described in Hex code.

Signals specified by n1, n2 are output to Connector Pin m.

- Bit m (m0) means the followings.

m0	Condition
0	Drawer kick No. 2 pin
1	Drawer kick No. 5 pin

- ON time is considered as n1 x 2ms and OFF time as n2 x 2ms.
- When m is out of the defined range, n1, n2 are discarded, where no signals are output.
- Drive duty of Drawer is shown below:

$$\frac{\text{ON time}}{\text{ON time} + \text{OFF time}} \leq 0.2$$

(Take OFF time as being 4 times or more longer than ON time.)

(23) Selecting Character Code Table (ESC t n)

Code : [1B]h + [74]h + n
 * {0 ≤ n ≤ 1} Data is described in Hex code.

Selecting Page n on the character code table:

- "n" means the followings.

n (Hex)	Condition
0	IBM Character #2
1	Japanese Character

(24) Transmitting the printer status (ESC v)

Code : [1B]h + [76]h

Current printer status is transmitted..

- Status sent out consists of 1 byte whose content is as in the table below.
- In DTR/DSR control, after receptive state of the host (DSR signal being in SPACE state) is confirmed, only 1 byte is transmitted. In XON/XOFF control, DSR signal state not being confirmed, only 1 byte is transmitted.
- In DTR/DSR control, when the host is in unreceptive state (DSR signal being in MARK state), it waits until receptive state is created.

IT	FUNCTION	VALUE	
		0	1
0	Paper near end	Paper available	Paper not available
1	Undefined		
2	Paper end	Paper available	Paper not available
3	Undefined		
4	Unused	Fixed to 0	-
5	Undefined		
6	Undefined		
7	Undefined		

Remarks. This command is valid only for serial interface model.

(25) Transmitting the status of Peripheral Equipment (ESC u n)

Code : [1B]h + [75]h + n
 * {n = 0}

Current status of connector pin No.3 is transmitted.

- "n" means the followings.

n (Hex)	Condition
0	Drawer Kick Connector No. 3

- Status transmitted consists of 1 byte whose content is as in the table below.
- Any equipment has not been connected to this connector, Bit 0 of n is always "1".
- In DTR/DSR control, after receptible state of the host (DSR signal being in SPACE state) is confirmed, only 1 byte is transmitted. Further, in XON/ XOFF control, DSR signal state not being confirmed, only 1 byte is transmitted.
- In DTR/DSR control, when the host is unreceptible state (DSR signal being in MARK state), it keeps waiting until receptible state is created.

BIT	FUNCTION	VALUE	
		0	1
0	Level of pin No. 3	"L"	"H"
1	Undefined		
2	Undefined		
3	Undefined		
4	Unused	Fixed to 0	-
5	Undefined		
6	Undefined		
7	Undefined		

Remarks This command is valid only for serial interface model.

(26)specifying/Canceling Inverted Characters (ESC {n)

Code : [1B]h + [7B]h + n
 * {0 ≤ n ≤ FF} Data is described in Hex code.

Specifying/canceling inverted characters.

- "n" is valid only for the lowest bit (n0).
- Bit n (n0) means the followings.

n	Condition
0	Canceling inverted characters.
1	Specifying inverted characters.

- This is valid only when this is specified at the beginning of a line.
- The printing example is shown below.
- The initial value of n is "0".

When inverted characters
have been canceled:

When inverted characters
have been assigned:

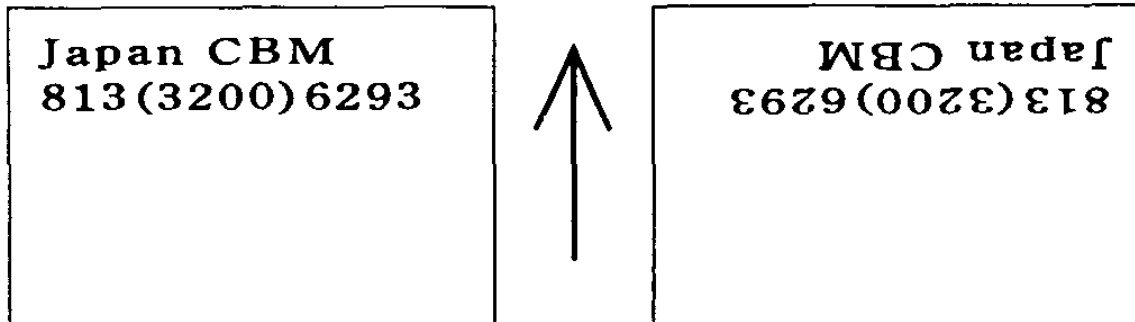

Paper feed direction

(27)Specifying/Canceling 90° - right- turned Characters (ESC V n)

Code : [1B]h + [56]h + n
 *{0 ≤ n ≤ 1} Data is described in Hex code.

Specifying/canceling characters 90°-right- turned character.

- No underlines are attached to 90°-right- turned characters .
- "n" means the followings.

(Hex)	Condition
0	Canceling 90° -right- turned Characters
1	Specifying 90° -right- turned Characters

- The initial value of n is "0".

(28) Specifying Absolute Positions (ESC \$ n1 n2)

Code : [1B]h + [24]h + n1 + n2

* {0 ≤ n1 ≤ FF}

{0 ≤ n2 ≤ 1} Data is described in Hex code.

The printing start position is specified in the number of dots from the beginning of line.

- The number of dots is divided by 256, whose quotient is taken as n2 and the residual as n1. Therefore, the printing start position is equal to n1 + n2 x 256 from the beginning of line..
- Specifying beyond the line end is ignored.

(29) Specifying Relative Positions (ESC ¥ n1 n2)

Code : [1B]h + [5C]h + n1 + n2

* {0 ≤ n1 ≤ FF}

{0 ≤ n2 ≤ FF} Data is described in Hex code.

- The printing start position is specified in the number of dots from the current position.
- Rightward direction is taken as plus and leftward direction as minus.
- To specify N dot in minus (left) direction, use a complement of N for assignment.
- N dots = 65536 - N
- The number of dots is divided by 256, whose quotient is taken as n2 and the residual as n1.
- Specifying exceeding the end of line is ignored.

(30)Bar Code Printing (GS k n Dn NUL)

Code : [1D]h + [6B]h + n + Dn + [00]h
 * {0 ≤ n ≤ 7} Data are described in Hex code.

Specifying a type of bar code and printing bar codes.

- The beginning of line is considered as the next printing start position.
- Depending on the value of n, the following bar code can be selected.
- Dn indicates a character code to be printed.

n (Hex)	Bar Code System
0	UPC-A
1	UPC-E
2	JAN13 (EAN)
3	JAN 8 (EAN)
4	CODE 39
5	ITF
6	CODABAR
7	CODE 128

- Data, when being held in the print buffer, are ignored.
- When the character code Dn cannot be printed, the data following after this is printed as ordinary print data.
- When a bar code whose number of characters to be printed is fixed has been selected, the number of characters have to be always made equal to the number of characters to be printed.
- When the horizontal direction exceeds one line length, the excess part is not printed.

(31) Selecting Bar Code width (GS w n)

Code : [1d]H + [77]H + N

* {2 ≤ n ≤ 4} Data is described in Hex code.

Selecting bar code width.

- The initial value of this width is "3".

(32) Selecting Bar Code Height (GS h n)

Code : [1d]H + [68]H + N

* {1 ≤ n ≤ FF} Data is described in Hex code.

Selecting bar code height.

- "n" indicates the number of dots in vertical direction.
- The initial value of n is "162".

(33) Selecting Printing Position of HRI Characters (GS H n)

Code : [1d]H + [48]H + N

* {0 ≤ n ≤ 3} Data is described in Hex code.

Selecting printing position of HRI characters for printing bar codes.

- "n" means the followings.

n (Hex)	Printing Position
0	No printing
1	Above the bar code
2	Below the bar code
3	Both above and below the bar code

- The initial value of n is "0".

(34) Selecting the Font of HRI characters (GS f n)

Code : [1D]h + [66]h + n

* {0 ≤ n1 ≤ 1} Data is described in Hex code.

Select the font of HRI characters when printing bar code.

- “n” has the following meanings.

n (Hex)	Font
0	Font A
1	Font B

(35) Defining Download Bit Image (GS * n1 n2 Dn)

Code : [1D]h + [2A]h + n1 + n2 Dn

* {1 ≤ n1 ≤ FF}

{1 ≤ n2 ≤ 48}

{n1 x n2 ≤ 1311} Data is described in Hex code.

Defines downloading bit images of the number of dots specified by n1/n2.

- The numbers of dots are n1 x 8 in horizontal direction and n2 x 8 in vertical direction.
- Dn indicates bit image data.
- The download bit image thus defined remains effective until redefinition, ESC @ execution, ESC &, or power OFF takes place.
- A download character and a download bit image cannot be defined simultaneously. With this command executed, defined content of a download character is cleared.
- Relations between the bit image data and the dot defined are shown below:

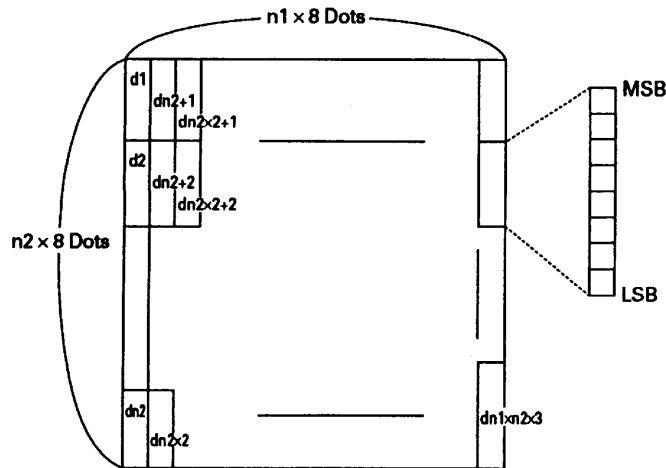

(36)Printing Download Bit Image (GS / m)

Code : [1D]h + [2F]h + m
 * {0 ≤ m ≤ 3} Data is described in Hex code.

Prints download bit images in a mode specified by m.

- Modes can be selected by m are shown table for selection with m are shown below.

	Mode Name	Vertical Dot Density	Horizontal Dot Density
0	Normal mode	203 DPI	203 DPI
1	Double wide mode	203 DPI	101 DPI
2	Double high mode	101 DPI	203 DPI
3	Double wide/double high mode	101 DPI	101 DPI

- When data exist inside the print buffer, this command is ignored.
- When a download bit image has not been defined, this command is ignored.
- A portion of a download bit image exceeding one line length is not printed.
- A download character and a download bit image cannot be defined simultaneously.

(37)Starting / Ending Macro Definition (GS :)

Code : [1D]h + [3A]h

Specifying starting / ending macro definition. Maximum content available for macro definition is 2048 bytes. A portion exceeding 2048 bytes is not defined.

- Even with ESC @ (initialization of the printer) having been executed, defined content is not cleared. Therefore, it is possible to include ESC @ into the content of macro definition.
- Normal printing operation is carried out even while in macro definition

(38) Macro Execution (GS^ n1 n2 n3)

Code : [1D]h + [5E]h + n1 + n2 + n3
 * {0 ≤ n1 ≤ FF}
 {0 ≤ n2 ≤ FF}
 {0 ≤ n3 ≤ 1} Data is described in Hex code.

Executing contents defined in macro.

- "n1-n3" indicate as follows:
 - n1 : The number of times of macro execution
 - n2 : Waiting time on macro execution
Waiting time of n2 x 100 msec is given for every execution.
 - n3 : Macro execution mode

n3	Mode
0	Continuous execution
1	Execution by the paper feed SW

Continuous execution : The Macro is executed n1 times continuously at the time intervals specified by n2.

Execution by FEED SW : After waiting for lapse of time specified by n2, the ERROR LED flickers and the paper feed switch is waited to be pressed. When it is pressed, the macro is executed once. This action is repeated n1 times.

- When this command is received while in macro definition, suspension of macro definition is indicated. At this time, the defined content is cleared.
- No execution takes place when macro is held undefined or n1=0.
- While in macro execution with n3=1, paper feed with the FEED SW is not available.

(38) Data Input Control (ESC = n)

Code : [1B]h + [3D]h + n

* {0 ≤ n ≤ FF} Data is described in Hex code.

Selecting equipment in which data input from the host is effective.

- Each bit of n indicates as follows:

IT	Device	VALUE	
		0	1
0	Printer	Invalid	Valid
1	Undefined		
2	Undefined		
3	Undefined		
4	Undefined		
5	Undefined		
6	Undefined		
7	Undefined		

- When the printer has not been selected, this printer abandons all received data until it is selected by this command.
- Even when the printer has not been selected, it can become BUSY state through printer operation.
- The initial value of n is "1".

(39) Aligning the characters (ESC a n)

Code : [1b]h + [61]h + n

* {0 ≤ n ≤ 2} Data is described in Hex code.

All the printed data within one line are aligned in the specified position.

- Depending on n value, positional alignment is carried out as in the table below:

n (Hex)	POSITION
0	Left end alignment
1	Centering
2	Right end alignment

- This is valid only when n is inputted at the beginning of line.
- The initial value of n is "0".

(40) Full Cut (ESC i)

Code : [1B]h + [69]h

Full cutting of paper is performed.

- This is valid only when n is inputted at the beginning of line.

(41) Partial Cut (ESC m)

Code : [1B]h + [6D]h

Partial cutting of paper is carried out.

- This is valid only when n is inputted at the beginning of line.

10 CHARACTER CODE TABLE

10.1 International

	0	1	2	3	4	5	6	7	8	9	A	B	C	D	E	F
0	DEL		SP	0	@	P	'	p	ç	é	À	☒	¸	¸	α	■
1		xxx	l	1	A	Q	a	q	ù	à	Ì	☒	¸	¸	β	±
2			'	2	B	R	b	r	é	Á	Ó	☒	¸	¸	Γ	≠
3		xxx	#	3	C	S	c	s	À	Ò	Ù		¸	¸	κ	≠
4			\$	4	D	T	d	t	Á	Ó	Ñ	¸	¸	¸	Σ	¸
5			%	5	E	U	e	u	À	Ô	Ñ	¸	¸	¸	σ	¸
6			&	6	F	V	f	v	À	Ù	Ì	¸	¸	¸	μ	+
7			'	7	G	W	g	w	ç	Ù	Ì	¸	¸	¸	τ	≠
8			(8	H	X	h	x	ó	Ý	¸	¸	¸	¸	Φ	·
9	HT)	9	I	Y	i	y	ó	Ù	¸	¸	¸	¸	θ	·
A	LP		*	:	J	Z	j	z	ó	Ù	¸		¸	¸	Ω	·
B		xxx	+	:	K	[k	(í	é	¸	¸	¸	¸	δ	√
C		PS	,	<	L	/	l		í	£	¸	¸	¸	¸	∞	·
D		GS	-	=	M]	m)	í	¥	¸	¸	¸	¸	φ	·
E			.	>	N	'	n	~	λ	℞	<	¸	¸	¸	ε	■
F			/	?	O	-	o	SP	λ	f	>	¸	¸	¸	∩	SP

10.2 International Character Code Table

	Country	23	24	40	5B	5C	5D	5E	60	7B	7C	7D	7E
0	U. S. A.	#	\$	@	[\]	^	`	()	~
1	France	#	\$	a	·	ç	§	^	`	é	ù	è	~
2	Germany	#	\$	§	λ	0	0	^	`	a	o	u	ü
3	U. K.	£	\$	@	[\]	^	`	()	~
4	Denmark I	#	\$	@	Æ	Ø	Λ	^	`	æ	ø	å	~
5	Sweden	#	κ	é	λ	0	λ	0	é	a	o	a	u
6	Italy	#	\$	@	·	\	é	^	ù	a	ó	è	ì
7	Spain	R	\$	@	i	Ñ	¿	^	`	~	n)	~
8	Japan	#	\$	@	[¥]	^	`	()	~
9	Norway	#	κ	é	Æ	Ø	Λ	0	é	æ	ø	å	u
10	Denmark II	#	\$	é	Æ	Ø	Λ	0	é	æ	ø	å	u

Appendix 1. Precaution and Maintenance

1.1 Precaution for Handling the Printer Mechanism

1. Use of unspecified paper may not assure you of printing quality and product life.
2. With the printing head kept down, do not turn the paper feed knob or pull out the paper.
3. Do not touch the heating element's surface of the head.

1.2 Precautions for Handling the Thermal Paper

1. A contact of chemicals or oil may discolor or erase the record.
2. Rubbing the paper hard with nail or hard metal may discolor it.
3. Discoloring starts at approximately 70°C. Pay attention to an effect of heat, humidity, light, etc.

1.3 Other Precautions

1. Be careful not to drop foreign matter such as clip, pin into the main body.
2. When cleaning the surface of the main body case, use neutral detergent.
Do not use alcohol, thinner, etc.

1.4 Eliminating the Jammed Paper

1. Open the auto cutter, move up the printing head, and eliminate the paper. (CBM-231)
 2. When the paper is coiling around the platen roller, eliminate it gradually, turning the paper feed knob.
- [Caution] Do not touch the printing head or motor immediately after printing because they are very hot.

1.5 Eliminating the Paper Powder

When the printer is contaminated with paper powder, clean it with a brush or vacuum cleaner.
[Caution] Do not touch the printing head or motor immediately after printing because they are very hot.

1.6 Cleaning the Head

1. Open the auto cutter and move up the printing head.(CBM-231)
 2. Use the cardboard and gauze as shown in the figure below.
 3. Dip the gauze slightly into alcohol, insert it in between the printing head and platen roller as shown in the figure, and clean by moving it aside.
- [Caution] Do not touch the printing head or motor immediately after printing because they are very hot.

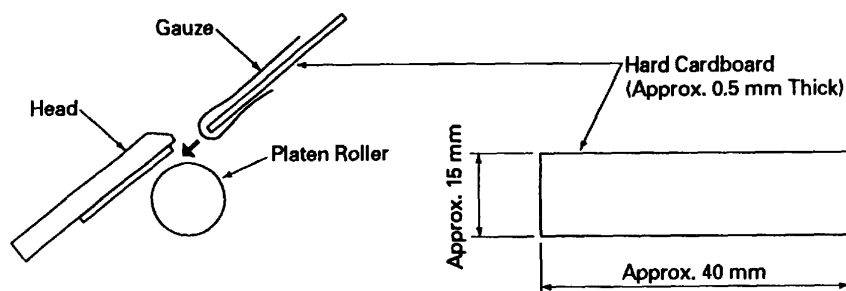

Appendix 2. External Dimensions

1. CBM-230

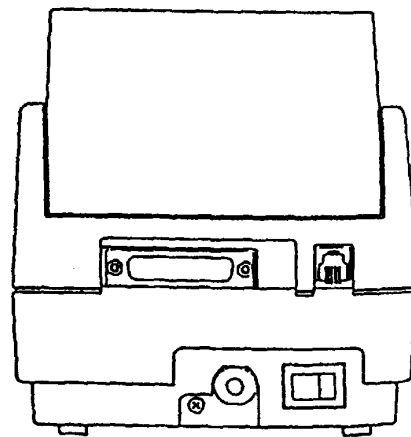
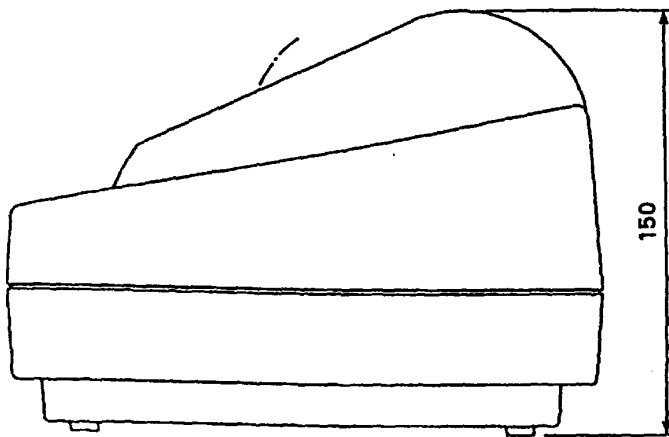
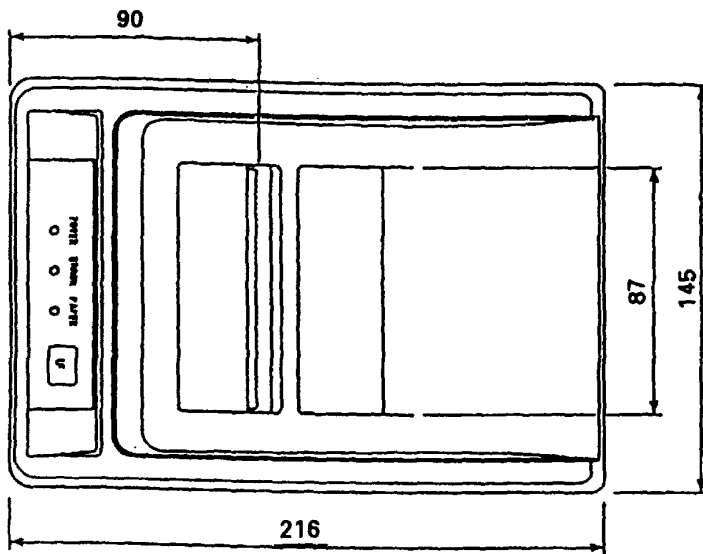

2. CBM-231

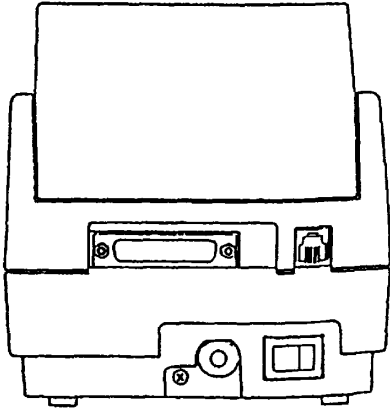
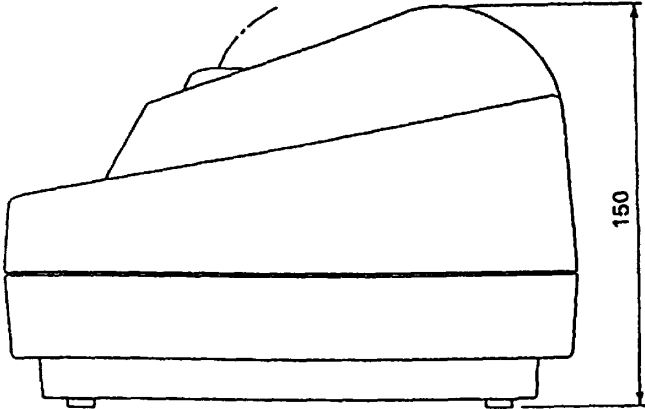
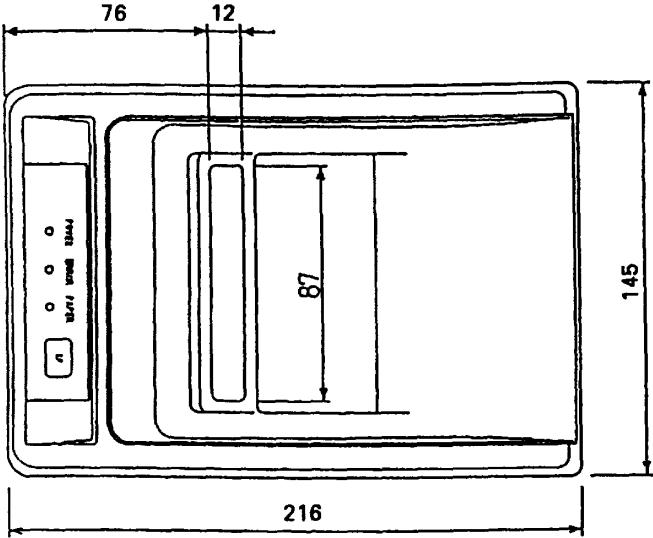

Appendix 3. Block Diagram

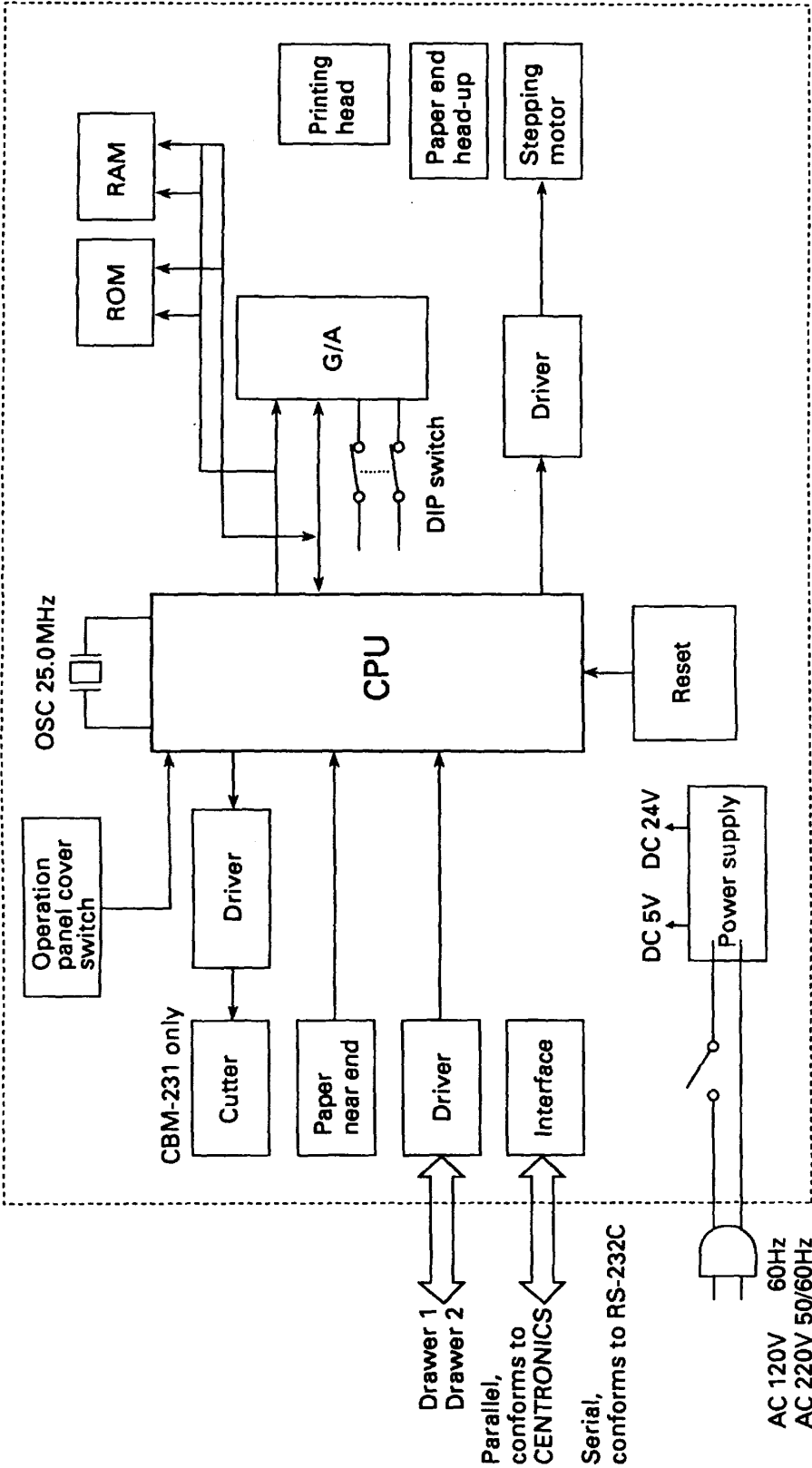

Free Manuals Download Website

<http://myh66.com>

<http://usermanuals.us>

<http://www.somanuals.com>

<http://www.4manuals.cc>

<http://www.manual-lib.com>

<http://www.404manual.com>

<http://www.luxmanual.com>

<http://aubethermostatmanual.com>

Golf course search by state

<http://golfingnear.com>

Email search by domain

<http://emailbydomain.com>

Auto manuals search

<http://auto.somanuals.com>

TV manuals search

<http://tv.somanuals.com>