

Clarion®

Owner's manual
Mode d'emploi
Manual de instrucciones

DRZ

9 2 5 5

HIGH-FIDELITY AM/FM CD PLAYER

LECTEUR AM/FM CD HAUTE FIDELITE

REPRODUCTOR DE CD CON AM/FM DE ALTA FIDELIDAD

ProAudio

CaNET

COMPACT
disc
DIGITAL AUDIO
TEXT

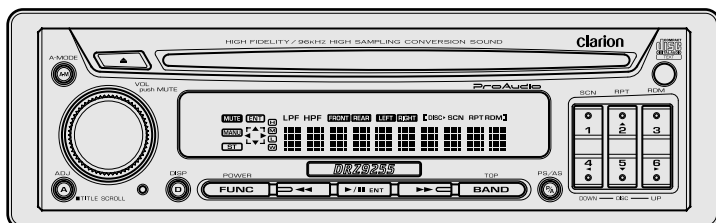

Thank you for purchasing this **Clarion** product.

- * Please read this owner's manual in its entirety before operating this equipment.
- * After reading this manual, be sure to keep it in a handy place (e.g., glove compartment).
- * Check the contents of the enclosed warranty card and keep it carefully with this manual.
- * This manual includes the operating procedures of the CD changer and TV tuner connected via the CeNET cable. The CD changer and TV tuner have their own manuals, but no explanations for operating them are described.

Contents

1. FEATURES	2
2. PRECAUTIONS	3
Handling Compact Discs	4
Digital Wiring	4
3. CONTROLS	5
4. NOMENCLATURE	6
Names of the Buttons and their Functions	6
Major Button Operations when External Equipment is Connected to this Unit	7
Display Items	8
5. REMOTE CONTROL	9
Inserting the Batteries	9
Functions of Remote Control Unit Buttons	10
6. OPERATIONS	11
Basic Operations	11
Radio Operations	13
CD Operations	14
Operations Common to Each Mode	16
7. OPERATIONS OF ACCESSORIES	25
CD Changer Operations	25
TV Operations	27
8. IN CASE OF DIFFICULTY	29
9. ERROR DISPLAYS	30
10. SPECIFICATIONS	30
APPENDIX : TIME ALIGNMENT LIST	32
MEMO : SOUND SETUP MEMO	34

1. FEATURES

- 96kHz High sampling conversion sound
- Burr Brown DACs / 0.5dB STEP Burr Brown Volume
- 6N 8ch / MAX 8 Volt Gold Plated RCA Line Level Output and 4-Channel RCA AUX Input with 3 Level Adjustments
- 0.7cm STEP Time alignment / 4WAY Cross-Over / 5-BAND Parametric EQ
- Direct (Front+Rear+Non-fader) / Standard (Front2Way+Rear+SUB) / 4-Way Multi Mode
- Aluminum Upper Covered DC-DC converter
- CeNET with Balanced Audio Line Transmission and Dynamic Noise Canceling
- IR Remote Control Included

2. PRECAUTIONS

1. When the inside of the car is very cold and the player is used soon after switching on the heater moisture may form on the disc or the optical parts of the player and proper playback may not be possible. If moisture forms on the disc, wipe it off with a soft cloth. If moisture forms on the optical parts of the player, do not use the player for about one hour. The condensation will disappear naturally allowing normal operation.
2. Driving on extremely bumpy roads which cause severe vibration may cause the sound to skip.
3. This unit uses a precision mechanism. Even if the disc that trouble arises, never open the case, disassemble the unit, or lubricate the rotating parts.

This equipment has been tested and found to comply with the limits for a Class B digital device, pursuant to Part 15 of the FCC Rules.

These limits are designed to provide reasonable protection against harmful interference in a residential installation.

This equipment generates, uses, and can radiate radio frequency energy and, if not installed and used in accordance with the instructions, may cause harmful interference to radio communications. However, there is no guarantee that interference will not occur in a particular installation.

If this equipment does cause harmful interference to radio or television reception, which can be determined by turning the equipment off and on, the user is encouraged to consult the dealer or an experienced radio/TV technician for help.

CAUTION

USE OF CONTROLS, ADJUSTMENTS, OR PERFORMANCE OF PROCEDURES OTHER THAN THOSE SPECIFIED HEREIN, MAY RESULT IN HAZARDOUS RADIATION EXPOSURE.

THE COMPACT DISC PLAYER and MINI DISC PLAYER SHOULD NOT BE ADJUSTED OR REPAIRED BY ANYONE EXCEPT PROPERLY QUALIFIED SERVICE PERSONNEL.

CHANGES OR MODIFICATIONS NOT EXPRESSLY APPROVED BY THE MANUFACTURER FOR COMPLIANCE COULD VOID THE USER'S AUTHORITY TO OPERATE THE EQUIPMENT.

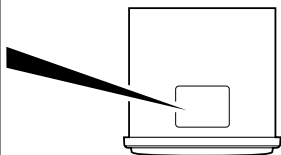
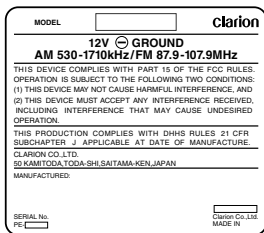

INFORMATION FOR USERS:
CHANGES OR MODIFICATIONS TO THIS PRODUCT NOT APPROVED BY THE MANUFACTURER WILL VOID THE WARRANTY AND WILL VIOLATE FCC APPROVAL.



Bottom View of Source Unit

English

Handling Compact Discs

Use only compact discs bearing the  or  mark.

Do not play heart-shaped, octagonal, or other specially shaped compact discs.

Some CDs recorded in CD-R/CD-RW mode may not be usable.

Handling

Compared to ordinary music CDs, CD-R and CD-RW discs are both easily affected by high temperature and humidity and some of CD-R and CD-RW discs may not be played. Therefore, do not leave them for a long time in the car.

New discs may have some roughness around the edges. If such discs are used, the player may not work or the sound may skip. Use a ball-point pen or the like to remove any roughness from the edge of the disc.

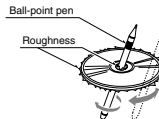

- Never stick labels on the surface of the compact disc or mark the surface with a pencil or pen.
- Never play a compact disc with any cellophane tape or other glue on it or with peeling off marks. If you try to play such a compact disc, you may not be able to get it back out of the CD player or it may damage the CD player.

- Do not use compact discs that have large scratches, are misshapen, cracked, etc. Use of such discs may cause misoperation or damage.
- To remove a compact disc from its storage case, press down on the center of the case and lift the disc out, holding it carefully by the edges.
- Do not use commercially available CD protection sheets or discs equipped with stabilizers, etc. These may damage the disc or cause breakdown of the internal mechanism.

Storage

- Do not expose compact discs to direct sunlight or any heat source.
- Do not expose compact discs to excess humidity or dust.
- Do not expose compact discs to direct heat from heaters.

Cleaning

- To remove fingermarks and dust, use a soft cloth and wipe in a straight line from the center of the compact disc to the circumference.
- Do not use any solvents, such as commercially available cleaners, anti-static spray, or thinner to clean compact discs.
- After using special compact disc cleaner, let the compact disc dry off well before playing it.

Digital Wiring

About Reset

Digital Output

- When a 5.1ch surround decoder is connected, switch the set to direct mode.

Digital Input

- When the optical digital cable is connected to or disconnected from this set later, press the function button while holding down direct buttons [1] and [6] with the power OFF to perform a system check. Though pressing the reset button also performs a system check, the contents of memory will be erased completely in this case.

Be sure to unfold and read the next page. / Veuillez déplier et vous référer à la page suivante.
Cerciórese de desplegar y de leer la página siguiente.

3. CONTROLS / LES COMMANDES / CONTROLES

Source unit / Appareil pilote / Unidad fuente

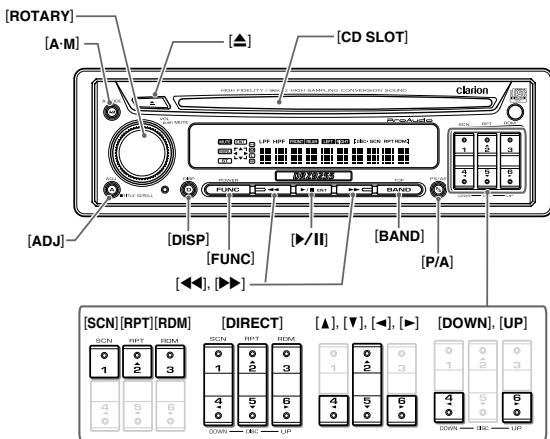

Note: Be sure to unfold this page and refer to the front diagrams as you read each chapter.
 Remarque: Veuillez déplier cette page et vous référer aux schémas quand vous lisez chaque chapitre.
 Nota: Cuando lea los capítulos, despliegue esta página y consulte los diagramas.

4. NOMENCLATURE

Note:

• Be sure to read this chapter referring to the front diagrams of chapter "3. CONTROLS" on page 5 (unfold).

Names of the Buttons and their Functions

[ROTARY] knob

- Adjust the volume by turning the knob clockwise or counterclockwise.
- Mute the sound. When the knob is pressed and held for 1 second or longer, the volume is changed from 1db steps to 0.5db steps.

[▲] button

- Eject a CD when it is loaded into the unit.

[CD SLOT]

- CD insertion slot.

[SCN] button

- Perform scan play for 10 seconds of each track while in the CD mode.

[RPT] button

- Repeat play while in the CD mode.

[RDM] button

- Perform random play while in the CD mode.

[DIRECT] buttons

- Store a station into memory or recall it directly while in the radio mode.

[▲], [▼], [←], [→] buttons

- Select items in the Adjust mode.

[UP], [DOWN] buttons

- Select the disc.

[P/A] button

- Perform preset scan while in the radio mode. When the button is pressed and held, auto store is performed.

[BAND] button

- Switch the band, or seek tuning or manual tuning while in the radio mode.
- Play a first track while in the CD mode.

[<<], [>>] buttons

- Select a station while in the radio mode or select a track when listening to a CD. These buttons are used to make various settings.
- Press and hold the button for 1 second or longer to switch the fast-forward/fast-backward.

[>||] button

- Play or pause a CD while in the CD mode.

[FUNC] button

- Press the button to turn on the power. Press and hold the button for 1 second or longer to turn off the power.
- Switches the operation mode among the radio mode, etc.

[DISP] button

- Switch the display indication (Main display, Sub display, Clock display).

[ADJ] button

- Press the button to enter the adjust mode.
- When the button is pressed and held for 1 second or longer, the title is scrolled.

[A-M] button

- Use the button to switch to the audio mode (bass/treble, balance/fader)
- Hold down for at least one second to turn the display OFF.

Major Button Operations when External Equipment is Connected to this Unit

● When the CD/DVD changer is connected

- * For details, see the section "CD changer operations". For the DVD changer, refer to the Owner's Manual provided with the DVD changer.

[SCN] button

- Perform scan play for 10 seconds of each track. Disc scan play is performed when the button is pressed and held.

[RPT] button

- Perform repeat play. When this button is pressed and held, disc repeat play is performed.

[RDM] button

- Perform random play. Also perform disc random play when the button is pressed and held.

[UP], [DOWN] buttons

- Select the disc.

[BAND] button

- Move the next disc in increasing order.

[◀◀], [▶▶] buttons

- Select a track when listening to a disc.
- Press and hold the button for 1 second or longer to switch the fast-forward/fast-backward.

[▶/II] button

- Play or pause a CD or DVD.

[DISP] button

- Press and hold the button to switch between the user titles or track titles, etc. while in the CD changer mode.

● When the TV is connected

- * For details, see the section "TV operations".

[DIRECT] buttons

- Store a station into memory or recall it directly.

[P/A] button

- Perform preset scan while in the TV mode. When the button is pressed and held, auto store is performed.

[BAND] button

- Switch the band.
- Press and hold the button to switch between seek tuning or manual mode.

[◀◀], [▶▶] buttons

- Select a station.

[▶/II] button

- Switch the TV picture mode or VTR (external) picture mode.

Display Items

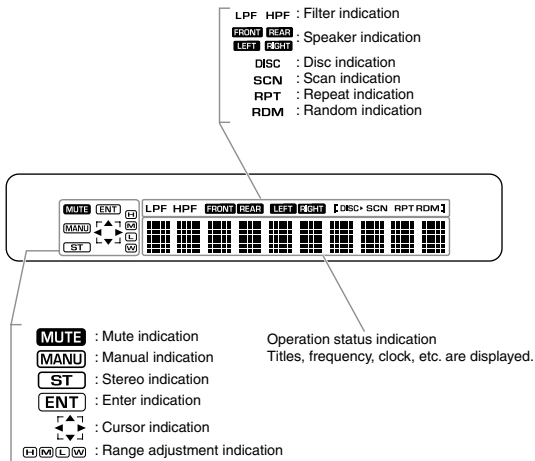

5. REMOTE CONTROL

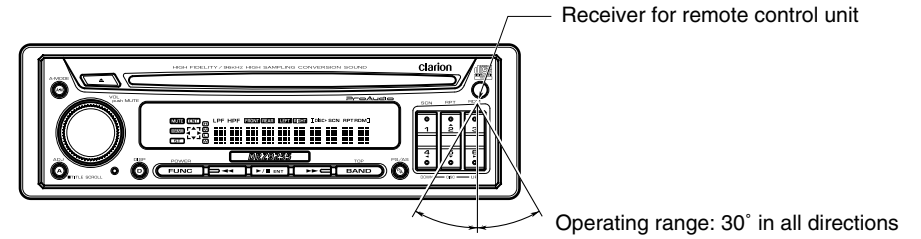

Remote control unit

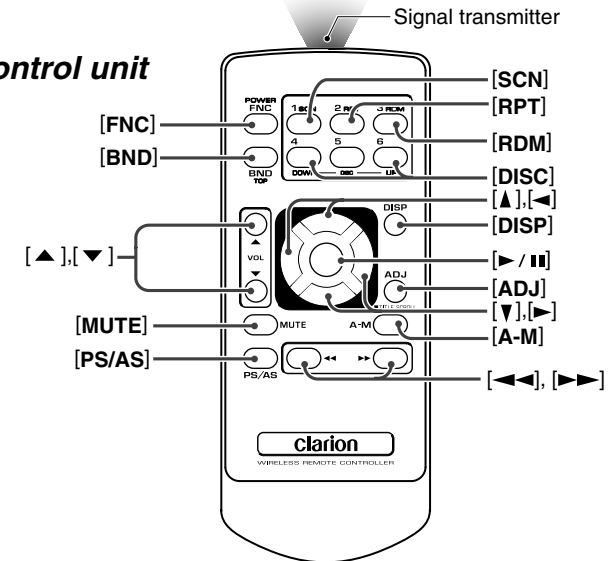

Inserting the Batteries

1. Turn the remote control over, and remove the rear cover with a sharp-pointed object while pressing in the direction of the arrow.
2. Insert batteries (CR2025) making sure that they face the directions shown in the figure.
3. Press in the cover until you hear it click into place.

Notes:

Using batteries improperly can cause them to explode. Take note of the following points:

- When replacing batteries, replace both batteries with new ones.
- Do not short-circuit, disassemble or heat batteries.
- Do not dispose of batteries into fire or flames.
- Dispose of spent batteries properly.

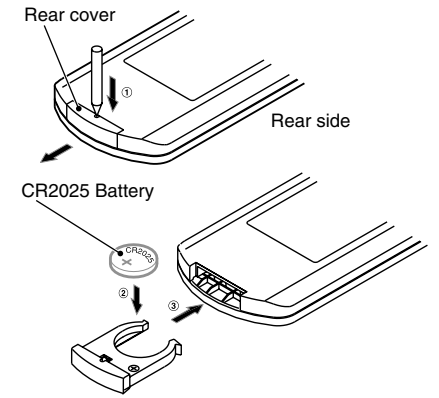

Functions of Remote Control Unit Buttons

Mode Button	Radio	CD	CD changer DVD changer	TV
[FNC]	Switches among radio, CD, CD changer, DVD changer, TV and AUX.			
[BND]	Switches reception band.	Plays the first track. Top play.	Moves the next disc in increasing order.	Switches reception band.
[▲], [▼]	Increases and decreases volume (in all modes).			
[←], [→]	Tunes in the desired station.	Moves tracks up and down. When pressed and held for 1 second: Fast-forward/fast-backward.		Tunes in the desired TV station.
[▶/⏸]	No function.	Switches between playback and pause.		Switches between TV and VTR.
[MUTE]	Turns mute on and off. Holding down the button for about one second changes the volume from 1dB steps to 0.5dB steps.			
[DISP]	Switches among main display, sub display, clock display.			
[SCN] [1]	Recalls the station in the memory. When pressed and held for 1 second: Manual memory.	Scan play.	Scan play. When pressed and held for 1 second: Disc scan play.	Recalls the station in the memory. When pressed and held for 1 second: Manual memory.
[RPT] [2]		Repeat play.	Repeat play. When pressed and held for 1 second: Disc repeat play.	
[RDM] [3]		Random play.	Random play. When pressed and held for 1 second: Disc random play.	
[DISC] [4][6]		No function.	[4]:Disk down. [6]:Disk up.	
[5]		No function.	No function.	
[▲][▼][←][→]	Select items in the Adjust mode.			
[PS/AS]	Preset scan. When pressed and held for 2 seconds: Auto store.	Scan play.	Scan play.	Preset scan. When pressed and held for 2 seconds: Auto store.
[ADJ]	Enters the adjust mode.	Enters the adjust mode. When pressed and held for 1 second: Title scroll.	Enters the adjust mode. When pressed and held for 1 second: Title scroll. (This function is only for CD changer.)	Enters the adjust mode.
[A-M]	Adjusts the tone, the balance, and the fader. When pressed and held for 1 second: Display off.			

* Some of the corresponding buttons on the main unit and remote control unit have different functions.

6. OPERATIONS

Basic Operations

Note: Be sure to read this chapter referring to the front diagrams of chapter "3. CONTROLS" on page 5 (unfold).

⚠ CAUTION

Be sure to lower the volume before switching off the unit power or the ignition key. The unit remembers its last volume setting. If you switch the power off with the volume up, when you switch the power back on, the sudden loud volume may hurt your hearing and damage the unit.

Turning on/off the power

Note:

• Be careful about using this unit for a long time without running the engine. If you drain the car's battery too far, you may not be able to start the engine and this can reduce the service life of the battery.

1. Press the [FUNC] button.
2. The illumination and display on the unit light up. The unit automatically remembers its last operation mode and will automatically switch to display that mode.
3. Press and hold the [FUNC] button for 1 second or longer to turn off the power for the unit.

Note:

• System check

The first time this unit is turned on after the wire connections are completed, it must be checked what equipment is connected. When the power is turned on, "SYSTEM CHK" and "Push POWER" appear in the display alternately, so press the [FUNC] button. The system check starts within the unit. When the system check is complete, press the [FUNC] button again.

Selecting a mode

1. Press the [FUNC] button to change the operation mode.
2. Each time you press the [FUNC] button, the operation mode changes in the following order:

Radio mode → CD mode → CD changer mode → DVD changer mode → TV mode → AUX mode → Radio mode...

* External equipment not connected with CeNET is not displayed.

Adjusting the volume

Turning the [ROTARY] knob clockwise increases the volume; turning it counterclockwise decreases the volume.

- * The volume level is from ---- (minimum) to +6dB (maximum).
- * Holding down the [ROTARY] knob switches the volume from 1dB steps to 0.5dB steps.

Mute the sound

To mute the volume during playback, press the [ROTARY] knob.

Switching the display

Press the [DISP] button to select the desired display.

Each time you press the [DISP] button, the display switches in the following order:

Main display

F1 98.10



Sub display

NO TITLE



Clock display

AM 10:00



Main display

* Once selected, the preferred display becomes the display default. When a function adjustment such as volume is made, the screen will momentarily switch to that function's display, then revert back to the preferred display several seconds after the adjustment.

Basic Operations

Turning on/off the display

You can turn the display ON/OFF by holding the [A-M] button down for at least one second. You can also turn the display ON by pressing the [DISP] button while the display is OFF.

Adjusting the tone

Press the [A-M] button and select the item to adjust. Each time you press the [A-M] button, the item changes in the following order:

* "BASS" and "TREB" are displayed when "BASS/TREB" are selected at EQ SELECT.

● When "STD" is set

"SW-VOL" *1 → "BASS" *2 → "TREBLE" *2 → "BAL" → "FADER" → Last function mode.

● When "DIRECT" is set

"N-FAD VOL" → "BAL" → "FADER" → Last function mode.

● When "MULTI" is set

"SW-VOL" *1 → "BASS" *2 → "TREBLE" *2 → "BAL" → Last function mode.

*1 The item can be adjusted when the sub-woofer setting is not set to "OFF".

*2 The item can be adjusted when "EQ SELECT" in the Adjust mode is set to "BASS/TREB".

Adjusting the volume of sub-woofer/non-fader output

These items can be adjusted when the sub-woofer/non-fader setting is "ST" (stereo) or "MONO" (monaural).

* The factory default setting is "0.0 dB".

1. Press the [A-M] button to select "SW-VOL" or "N-FAD VOL".
 - * Select "SW-VOL" when the Audio mode is the Standard mode or the Multi mode, and "N-FAD VOL" when the Audio mode is the Direct mode.
2. Press the [▲] or [▼] button to set the output volume.
 - * The adjustment range is -10.0 dB to +10.0 dB (0.5 dB steps).
3. Press the [A-M] button several times to return to the previous mode.

Adjusting the bass/treble

This function is used to set the tone in more detail for listening.

- The tone can be adjusted when the Equalizer mode is set to "BASS/TREB".
 - * This can be adjusted when the Audio mode is the Standard mode or the Multi mode.
 - * The factory default setting is "0 dB".
1. Press the [A-M] button to select "BASS" or "TREB".
 2. Press the [▲] or [▼] button to adjust the output volume.
 - * The adjustment range is -12 dB to +12 dB
 3. Press the [A-M] button several times to return to the previous mode.

Adjusting the balance/fader

- "FADER" (fader) can be adjusted when the Audio mode is the Standard mode or the Direct mode.

* The factory default setting is "0".

1. Press the [A-M] button to select "BAL" or "FADER".
2. Press the [▲] or [▼] button to adjust the volume.
 - * The adjustment range is L13 to R13.

● Adjusting the balance (volume of the left and right speakers)

To enhance the left side, press the [▼] button.

To enhance the right side, press the [▲] button.

* The adjustment range is L13 to R13.

- #### ● Adjusting the fader (volume of the front and rear speakers)
- To enhance the rear side, press the [▼] button.
- To enhance the front side, press the [▲] button.
- * The adjustment range is R12 to F12.
3. Press the [A-M] button several times to return to the previous mode.

Radio Operations

FM reception

For enhanced FM performance the **MAGI-TUNE**® tuner includes signal actuated stereo control, Enhanced Multi AGC, Impulse noise reduction circuits and Multipath noise reduction circuits.

Listening to the radio

1. Press the [FUNC] button and select the radio mode. The frequency appears in the display.
2. Press the [BAND] button and select the radio band. Each time the button is pressed, the radio reception band changes in the following order:
FM1 → FM2 → FM3 → AM → FM1...
3. Press the [◀◀] or [▶▶] button to tune in the desired station.

Tuning

There are 3 types of tuning mode available, seek tuning, manual tuning and preset tuning.

Seek tuning

1. Press the [BAND] button and select the desired band (FM or AM).
 - * If "MANU" is lit in the display, press and hold the [BAND] button for 1 second or longer. "MANU" in the display goes off and seek tuning is now available.
2. Press the [◀◀] or [▶▶] button to automatically seek a station.

When the [▶▶] button is pressed, the station is sought in the direction of higher frequencies; if the [◀◀] button is pressed, the station is sought in the direction of lower frequencies.

Manual tuning

There are 2 ways available: Quick tuning and step tuning.

When you are in the step tuning mode, the frequency changes one step at a time. In the quick tuning mode, you can quickly tune the desired frequency.

1. Press the [BAND] button and select the desired band (FM or AM).
 - * If "MANU" is not lit in the display, press and hold the [BAND] button for 1 second or longer. "MANU" is lit in the display and manual tuning is now available.
2. Tune in a station.

● Quick tuning:

Press and hold the [◀◀] or [▶▶] button for 1 second or longer to tune in a station.

● Step tuning:

Press the [◀◀] or [▶▶] button to manually tune in a station.

Recalling a preset station

A total of 24 preset positions (6-FM1, 6-FM2, 6-FM3, 6-AM) exist to store individual radio stations in memory. Pressing the corresponding [DIRECT] button recalls the stored radio frequency automatically.

1. Press the [BAND] button and select the desired band (FM or AM).
2. Press the corresponding [DIRECT] button to recall the stored station.
 - * Press and hold one of the [DIRECT] buttons for 2 seconds or longer to store that station into preset memory.

Manual memory

1. Select the desired station with seek tuning, manual tuning or preset tuning.
2. Press and hold one of the [DIRECT] buttons for 2 seconds or longer to store the current station into preset memory.

Auto store

Auto store is a function for storing up to 6 stations that are automatically tuned in sequentially. If 6 receivable stations cannot be received, a previously stored station remains unoverwritten at the memory position.

1. Press the [BAND] button and select the desired band (FM or AM).
2. Press and hold the [P/A] button for 2 seconds or longer. The stations with good reception are stored automatically to the preset channels.
 - * If auto store is performed in the FM bands, the stations are stored in FM3 even if FM1 or FM2 was chosen for storing stations.

Preset scan

Preset scan receives the stations stored in preset memory in order. This function is useful when searching for a desired station in memory.

1. Press the [P/A] button.
2. When a desired station is tuned in, press the [P/A] button again to continue receiving that station.

Note:



- Be careful not to press and hold the [P/A] button for 2 seconds or longer, otherwise the auto store function is engaged and the unit starts storing stations.

Loading a CD

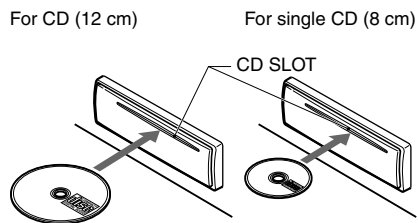
Insert a CD into the center of the CD SLOT with the labeled side facing up. "LOADING" appears in the display, the CD enters into the slot, and the play starts.



Notes:

- Never insert foreign objects into the CD SLOT.
- If the CD is not inserted easily, there may be another CD in the mechanism or the unit may require service.
- Discs not bearing the  or  mark and CD-ROMs cannot be played by this unit.
- Some CDs recorded in CD-R/CD-RW mode may not be usable.

Loading 8 cm compact discs

- * No adapter is required to play an 8 cm CD.
- * Insert the 8 cm CD into the center of the insertion slot.

Listening to a CD already inserted

Press the [FUNC] button to select the CD mode. Play starts automatically. If no CD is loaded in the unit, "NO DISC" appears in the display.

Pausing play

1. Press the [▶/||] button to pause play. "PAUSE" appears in the display.
2. To resume CD play, press the [▶/||] button again.

Displaying CD titles

This unit can display title data for CD-text CDs and user titles input with this unit.

1. Press the [DISP] button to display the title.
2. Each time you press and hold the [DISP] button for 1 second or longer, the title display changes in the following order:
CD-text title (disc) → Artist name → CD-text title (track) ...

Note:

- If the CD playing is not a CD-text CD or no user title has been input, "NO TITLE" appears in the display.

Ejecting a CD

1. Press the [▲] to eject the CD. Take it out from the ejected position.

Note:

- If you force a CD into before auto reloading, the CD can be damaged.
- * If a CD (12 cm) is left in the ejected position for 15 seconds, the CD is automatically reloaded (Auto reload).
- * 8 cm CDs are not auto reloaded. Be sure to remove it when ejected.

Selecting a track

● **Track-up**

1. Press the [▶▶] button to move ahead to the beginning of the next track.
2. Each time you press the [▶▶] button, the track advances ahead to the beginning of the next track.

● **Track-down**

1. Press the [◀◀] button to move back to the beginning of the current track.
2. Press the [◀◀] button twice to move to the beginning of the previous track.

Fast-forward/fast-backward

● **Fast-forward**

Press and hold the [▶▶] button for 1 second or longer.

● **Fast-backward**

Press and hold the [◀◀] button for 1 second or longer.

Top function

The top function resets the CD player to the first track of the disc. Press the [BAND] button to play the first track (track No. 1) on the disc.

Scan play

The scan play locates and plays the first 10 seconds of each track on a disc automatically. This function continues on the disc until it is cancelled.

* The scan play is useful when you want to select a desired track.

1. Press the [SCN] button to start scan play. "SCN" lights in the display.
2. To cancel the scan play, press the [SCN] button again. "SCN" goes off from the display and the current track continues to play.

Repeat play

The repeat play continuously plays the current track. This function continues automatically until it is cancelled.

1. Press the [RPT] button. "RPT" lights in the display and the current track is repeated.
2. To cancel the repeat play, press the [RPT] button again. "RPT" goes off from the display and normal play resumes.

Random play

The random play selects and plays individual tracks on a disc in no particular order. This function continues automatically until it is cancelled.

1. Press the [RDM] button. "RDM" lights in the display, an individual track is selected randomly and play begins.
2. To cancel the random play, press the [RDM] button again. "RDM" goes off from the display and normal play resumes.

Setting the clock

This unit displays the time when the car engine is running (ACC ON).
The clock is displayed in 12-hour format.

- When a navigation system is connected, the clock cannot be adjusted as clock data is sent from the navigation system.

1. Press the [ADJ] button. The previously adjusted item "CLOCK", for example, is displayed on the title display, and the mode changes to the Adjust mode.
2. Press the [◀] or [▶] button to select "CLOCK".
3. Press the [▶/||] button. The time at adjustment (e.g. "PM 2:20") is displayed, and the mode changes to the Clock setup mode.



* The clock is not adjusted if you press any other button while you are setting the clock.

4. Press the [◀] or [▶] button to select hours or minutes. Items that are blinking can be adjusted.
5. Press the [▲] or [▼] button to set the setting for the item.
6. Press the [▶/||] button. You will hear a short high-pitched sound, and the clock will be set.

Note:

- You cannot set the clock when it is displayed with the power turned OFF.
- Set the clock again if you remove the battery for inspection or repairs.

7. Press the [ADJ] button to return to the previous mode.

Selecting the sampling frequency (SAMPLING)

●About the sampling frequency

You can switch between 96 kHz and 48 kHz as the sampling frequency.

When the sampling frequency is set to 96 kHz, high band spread, depth of tones and transparency of sound are improved.

* The factory default setting is "fs=96 kHz".

1. Press the [ADJ] button.
2. Press the [◀] or [▶] button to select "SAMPLING".
3. Press the [▲] or [▼] button to select "fs=96kHz" or "NORMAL" (fs=48kHz).
4. Press the [ADJ] button to return to the previous mode.

Selecting the audio mode (MODE)

* The factory default setting is "STANDARD".

●Standard mode <STANDARD>/Multi mode <MULTI>

This is used to make various sound adjustments for playback. For details, see "About the Standard mode and Multi mode" (page 18)

●Direct mode <DIRECT>

This is used to playback tones as they are without adjusting the tones of this unit. The configuration of the speaker system becomes "front (2ch) + rear (2ch) + non-fader (2ch)."

1. Press the [ADJ] button.
2. Press the [◀] or [▶] button to select "MODE".
3. Press the [▲] or [▼] button to select "STANDARD", "DIRECT" or "MULTI".
4. Press the [ADJ] button to return to the previous mode.

Adjusting the filter (FILTER/X-OVER)

The filter can be adjusted for each speaker. For details, see "About filter settings" (page 18).

* The filter can be adjusted when the Audio mode is the Standard mode or the Multi mode.

1. Press the [ADJ] button.
2. Press the [◀] or [▶] button to select "SOUND".
3. Press the [▶/||] button.
4. Press the [▲] or [▼] button to select "FILTER" or "X-OVER".
* Select "FILTER" when the Audio mode is the Standard mode, and "X-OVER" when the Audio mode is the Multi mode.
5. Press the [◀] or [▶] button to select "[H] FRONT" or "[H] HIGH".
* Select "[H] FRONT" when the Audio mode is the Standard mode, and "[H] HIGH" when the Audio mode is the Multi mode.
6. Press the [▲] or [▼] button to select the speaker to adjust.
* The mute function of a selected speaker can be turned ON/OFF by pressing the [ROTARY] knob while the speaker is selected.

Each press of the buttons switches the setting as follows:

In the Standard mode:

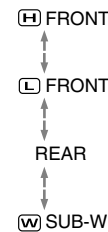

In the Multi mode:

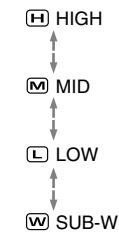

7. Press the [▶] button.
8. Press the [▲] or [▼] button to select the speaker adjustment item. Each press of the buttons switches the adjustment item.



fc LPF (filter frequency of low-pass filter)*

SLP LPF (filter slope of low-pass filter)*

fc HPF (filter frequency of high-pass filter)*

SLP HPF (filter slope of high-pass filter)*

G (gain)*

PHASE (phase)*

* Sometimes this is not displayed depending on the selected speaker.

9. Press the [▶/||] button. The setting value blinks.
10. Press the [▲] or [▼] button to adjust the setting.
* For details of the adjustment ranges of each adjustment item, see "About filter settings" (page 18).
11. When you have finished the adjustment, press the [▶/||] button to return to the screen in step 8. This sets the setting value.
12. Repeat steps 8 to 11 to adjust the adjustment items for the selected speaker.
13. When you have finished the adjustment, press the [◀] button to return to the screen in step 6.
14. Repeat steps 6 to 13 to adjust the filter of each speaker.
15. Press the [ADJ] button to return to the previous mode.

About the Standard mode and Multi mode

These two modes can be used to make the following various sound adjustments for playing back music sources:

- Setting of the filter (high-pass filter and low-pass filter) frequency for each speaker
- Tone adjustment by P.EQ (parametric equalizer) or BASS/TREB (bass/treble)
- Position setting by TIME ALIGN (time alignment)
- Sub-woofer "ST" (stereo), "MONO" (monaural) and "OFF"

Select the Standard mode or the Multi mode according to your speaker configuration.

- Standard mode: FRONT(2ch) + FRONT(2ch) + REAR(2ch) + SUB-W(2ch)
- Multi mode: HIGH(2ch) + MID(2ch) + LOW(2ch) + SUB-W(2ch)

●About filter settings

The following filters can be set for each speaker:

- Filter frequency (fc)
- Filter slope (SLP)
- Gain (G)
- Phase (PHASE)

Notes:

- Input of a low-band signal to the tweeter may cause a malfunction.

About filter frequency (fc)

The filter (high-pass filter and low-pass filter) frequency can be set for each speaker according to the characteristics of the speaker. Set the lower limit frequency to be played back mainly on that speaker on the high-pass filter (simply called "HPF" from here on), and set the upper limit frequency on the low-pass filter (simply called "LPF" from here on).

When HPF is set to "2kHz" and LPF is set to "20kHz"

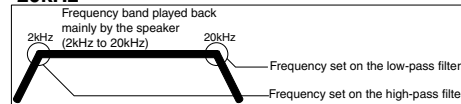

When the filter is set to "THROUGH", the setting for that filter is disabled, and all frequencies are played back.

When HPF is set to "2kHz" and LPF is set to "THROUGH"

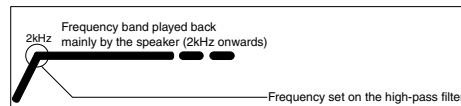

When HPF is set to "THROUGH" and LPF is set to "20kHz"

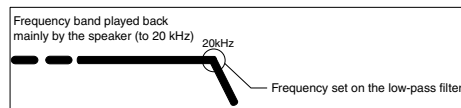

The following figure shows the factory default settings for filter frequencies in the Multi mode.

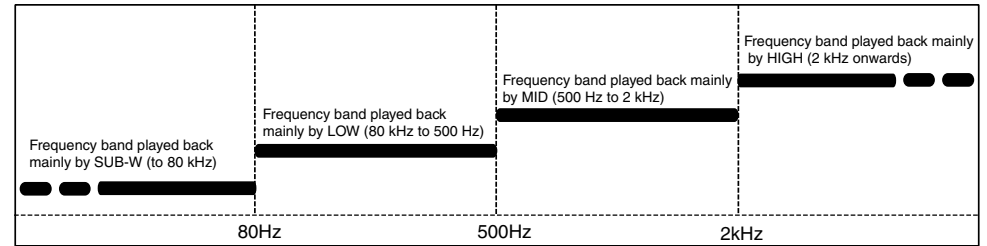

The filter frequency ranges that can be set vary according to the speaker. The following table shows these ranges.

Note, however, that the frequencies are selected from the value (1/3 octave steps) currently set on this unit.

	Speaker	HPF (lower limit frequency)	LPF (upper limit frequency)
Standard	<input checked="" type="checkbox"/> FRONT	315Hz to 20kHz (factory default setting: 2kHz)	-
	<input checked="" type="checkbox"/> FRONT	-	250Hz to 20kHz, THROUGH (factory default setting: 2kHz)
	REAR	THROUGH, 25Hz to 250Hz (factory default setting: THROUGH)	-
	<input checked="" type="checkbox"/> SUB-W	THROUGH, 16Hz to 80Hz (factory default setting: THROUGH)	25Hz to 250Hz, THROUGH (factory default setting: 80Hz)
Multi	<input checked="" type="checkbox"/> HIGH	315Hz to 20kHz (factory default setting: 2kHz)	-
	<input checked="" type="checkbox"/> MID	THROUGH, 200Hz to 10kHz (factory default setting: 500 Hz)	250Hz to 20kHz, THROUGH (factory default setting: 2kHz)
	<input checked="" type="checkbox"/> LOW	THROUGH, 25Hz to 250Hz (factory default setting: 80Hz)	250Hz to 10kHz, THROUGH (factory default setting: 500 Hz)
	<input checked="" type="checkbox"/> SUB-W	THROUGH, 16Hz to 80Hz (factory default setting: THROUGH)	25Hz to 250Hz, THROUGH (factory default setting: 80Hz)

-: THROUGH (fixed) cannot be changed.

About filter slope (SLP)

Effectiveness can be adjusted for each filter (HPF or LPF).

"-12dB/oct" is more effective than "-6dB/oct" and "-18dB/oct" is much more effective.

The factory default setting is "-12dB/oct". Try switching between "-6dB/oct", "-12dB/oct" and "-18dB/oct" and select the setting that sounds most natural to you.

●Characteristics during filter slope adjustment

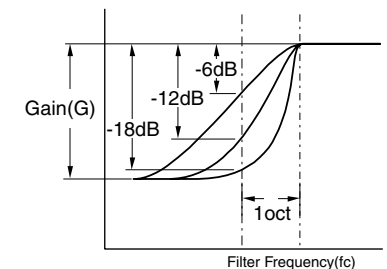

Operations Common to Each Mode

About gain (G)

This function allows you to adjust how much the output level is to be lowered.

●Characteristics during gain adjustment



About phase (PHASE)

The factory default setting is "NOR" (forward phase). Try switching between "NOR" (forward phase) and "REV" (reverse phase) and select the setting that sounds most natural to you.

Adjusting the position (TIME ALIGN)

●About the time alignment function

This function allows you to adjust the speakers so that any listener in the car can obtain the same sound effect from the speakers.

* This item can be adjusted when the Audio mode is the Standard mode or the Multi mode.

1. Press the [ADJ] button.
2. Press the [◀] or [▶] button to select "SOUND".
3. Press the [▶/||] button.
4. Press the [▲] or [▼] button to select "TIME ALIGN".
5. Press the [◀] or [▶] button to select "[F] FRONT LEFT" or "[F] HIGH LEFT".
 - * Select "[F] FRONT LEFT" when the Audio mode is the Standard mode, and "[F] HIGH LEFT" when the Audio mode is the Multi mode.
6. Press the [▲] or [▼] button to select the speaker to adjust.

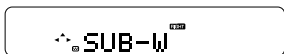

* The mute function of a selected speaker can be turned ON/OFF by pressing the [ROTARY] knob while the speaker is selected.

Each press of the button switches the setting as follows.

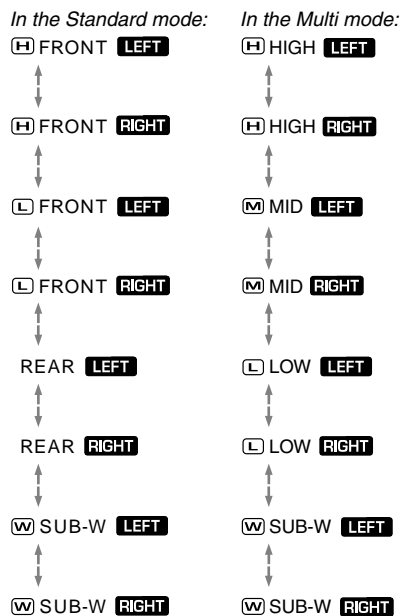

7. Press the [▶] button. The setting value is displayed.



8. Press the [▶/||] button. The setting value blinks.
9. Press the [▲] or [▼] button to set the distance from the speaker up to the listener.
 - * The adjustment range is 0 cm to 512.4 cm (in about 0.7 cm steps).
 - * The range can be adjusted in about 7 cm steps by holding down the [▲] or [▼] buttons.
 - * For details, see "Appendix : Time Alignment List" (page 32).
10. When you have finished the adjustment, press the [▶/||] button to return to the screen in step 7. This sets the setting value.
11. Press the [◀] button to return to the screen in step 6.
12. Repeat steps 6 to 11 to adjust the position of each speaker.
13. Press the [ADJ] button to return to the previous mode.

Operations Common to Each Mode

Adjusting P.EQ

●About P.EQ (Parametric Equalizer)

This function allows you to correct in detail all frequency levels by a smooth curve by correcting frequencies matched to the type of your car.

* This can be adjusted when the Equalizer mode is set to "P.EQ".

* This can be adjusted when the Audio mode is the Standard mode or the Multi mode.

1. Press the [ADJ] button.
2. Press the [◀] or [▶] button to select "SOUND".
3. Press the [▶/||] button.
4. Press the [▲] or [▼] button to select "P.EQ".
5. Press the [▶] button.
6. Press the [▲] or [▼] button to select the adjustment item.



* Pressing the [ROTARY] knob while the L/R channel is selected turns the mute function of the selected channel ON/OFF.

Each press of the button switches the setting as follows.

P.EQ ON/OFF: ON/OFF

P.EQ LEFT/RIGHT: Left channel/Right channel

BAND: band (1 to 5)

fo: frequency (BAND 1,2,3 : 50 Hz to 20 kHz)
(BAND 4,5 : 630 Hz to 20 kHz)

G: gain (-12 dB to +12 dB)

Q: Q-curve (0.5 to 12.0)

C: copy

●About P.EQ adjustment

The P.EQ menu contains the following adjustment items.

- Selection of channel (LEFT/RIGHT)
Select the channel (left or right) to be adjusted.
- Selection of band (BAND)
Select the frequency band (1 to 5) to be adjusted.
- Selection of center frequency (fo)
Select the frequency to be taken as the center frequency in frequency correction.
Bands 1 to 3: Select from the range 50 Hz to 20 kHz (1/3 octave steps, 27 points)
Bands 4 and 5: Select from the range 630 Hz to 20 kHz (1/3 octave steps, 16 points)
- Gain adjustment (GAIN)
Gain (output level) can be adjusted within the range -12 dB to +12 dB.
(0.5 dB steps, 49 points)
- Selection of Q-curve (Q)
Select the sharpness of the Q-curve within the range 0.5 to 12.0.
(0.5 steps, 24 points)
- Copying adjustment values (COPY)
Select whether or not to copy the channel settings currently being adjusted to another channel. When you press the [▶/||] button, the copy confirmation screen is displayed.

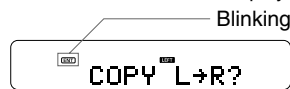

* L: shows the channel being adjusted while R: shows un-adjusted channels.

Holding down the [▶/||] button for about 1 second copies the settings, and returns to the previous screen.
To return to the previous screen without copying the settings, press the [▶/||] button.

●About correction

When the frequency characteristics are measured by a measuring device, they do not need to be corrected if the frequency characteristics are flat (no ridges or valleys in the frequency waveform). However, frequency characteristics sometimes partially rise up or fall down. If this happens, create a frequency curve of inverse characteristics matched to the center frequency of the ridges or valleys in the frequency waveform. This corrects the frequency characteristics so that they are flat.

"Correction" is the process of making frequency characteristics as flat as possible.

About correction of frequency characteristics

The following figure shows the relationship between center frequency, gain and Q-curve.

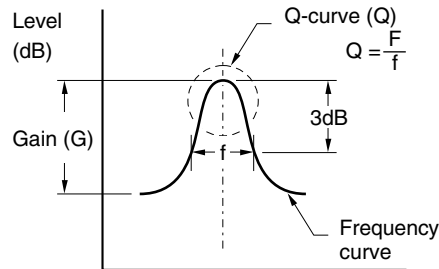

About Q-curve

The following figure and the table show the relationship between center frequency, gain and Q-curve.

When a large numerical value is set, the Q-curve becomes sharper, and when a small numerical value is set, the Q-curve becomes gentler.

Flat frequency characteristics can be made by selecting a Q-curve inverted to the frequency curve to be corrected.

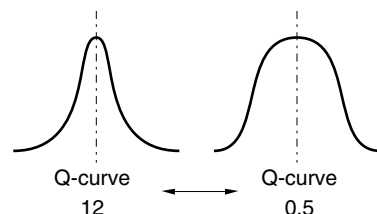

fo: Center frequency, G: gain (output level), Q: Q-curve

BAND	Parametric equalizer parameters					
	Left channel			Right channel		
	fo	G	Q	fo	G	Q
BAND1	50Hz*1	0dB	1	50Hz*1	0dB	1
BAND2	160Hz*1	0dB	1	160Hz*1	0dB	1
BAND3	500Hz*1	0dB	1	500Hz*1	0dB	1
BAND4	2kHz*2	0dB	1	2kHz*2	0dB	1
BAND5	8kHz*2	0dB	1	8kHz*2	0dB	1

*1 Select from range 50 Hz to 20 kHz

*2 Select from range 630 Hz to 20 kHz

Saving the filter setting/time alignment setting/P.EQ setting (MEMORY)

Three groups of adjustment settings made to suit your car can be saved for both the Standard mode and Multi mode.

* P.EQ settings are not saved when the Equalizer mode is set to "BASS/TREB".

1. Press the [ADJ] button.
2. Press the [◀] or [▶] button to select "SOUND".
3. Press the [▶/||] button.
4. Press the [▲] or [▼] button to select "MEMORY".
5. Press the [▶] button.
6. Press the [▲] or [▼] button to select "MEMORY1", "MEMORY2", "MEMORY3" or "DEFAULT".
* The factory default setting is "DEFAULT". This setting can be called up but cannot be changed to other settings.
7. Hold down the [▶/||] button for about 1 second. "SAVE?" is displayed.
8. Hold down the [▶/||] button for about 1 second. You will hear a short high-pitched sound, and the filter settings, time alignment settings and P.EQ settings are saved to the memory (1 to 3) selected in step 6.
9. Press the [ADJ] button to return to the previous mode.

●To call up saved settings

At step 7, press the [▶/||] button, and hold down the [▶/||] button for about 1 second when "LOAD?" is displayed.

You will hear a short high-pitched sound, and the settings are called up. Press the [ADJ] button to return to the previous mode.

* When the Equalizer mode is set to "BASS/TREB", the P.EQ settings that are called up are reflected when the Equalizer mode setting is changed to "P.EQ".

●About settings after a reset

When the [RESET] button is pressed to reset this unit, all settings set here disappear. Make a note of the settings in the Sound Setup Memo (page 34) to make these settings again after a reset.

Selecting the equalizer mode (EQ SELECT)

This item can be selected when the Audio mode is the Standard mode or the Multi mode.

The factory default setting is "P.EQ".

●Parametric equalizer mode <P.EQ>

The sound field can be adjusted by the P.EQ of five bands. For details on P.EQ adjustment, see "Adjusting P.EQ" (page 21).

●Bass/treble mode <BASS/TREB>

The sound field can be adjusted by bass/treble. For details on bass/treble adjustment, see "Adjusting the bass/treble" (page 12).

1. Press the [ADJ] button.
2. Press the [◀] or [▶] button to select "EQ SELECT".
3. Press the [▲] or [▼] button to select "P.EQ" or "BASS/TREB".
4. Press the [ADJ] button to return to the previous mode.

Setting the sub-woofer/non-fader (SUB-WOOFER/NON-FADER)

Set to "ST" (stereo) or "MONO" (monaural) when a sub-woofer/non-fader is connected. There is no output when "OFF" is set.

* The factory default setting is "ST".

1. Press the [ADJ] button.
2. Press the [◀] or [▶] button to select "SUB-WOOFER" or "NON-FADER".
* Select "SUB-WOOFER" when the Audio mode is the Standard mode or the Multi mode, and "NON-FADER" when the Audio mode is Direct mode.
3. Press the [▲] or [▼] button to select "ST" (stereo), "MONO" (monaural) or "OFF".
4. Press the [ADJ] button to return to the previous mode.

Operations Common to Each Mode

Setting the input level for portable audio (AUX SENS)

This unit is provided with two AUX input lines. The input level for third-party portable audio connected to each of these lines can be set.

* The factory default setting is "MID".

1. Press the [ADJ] button.
2. Press the [◀] or [▶] button to select "AUX SENS".
3. Press the [▶/II] button.
4. Press the [▲] or [▼] button to select the input line.



Each press of the button switches the line as follows:

AUX1 SENS: Input line 1



AUX2 SENS: Input line 2

5. Press the [▶] button.
6. Press the [▲] or [▼] button to select "HIGH", "MID" or "LOW".
7. When you select this, press the [◀] button to return to the screen in step 4.
8. Repeat steps 4 to 7 to set the input level of each input line.
9. Press the [ADJ] button to return to the previous mode.

Setting the digital output (D-OUT)

Set digital output ON when the digital output connector is used as the digital output connector of the built-in CD. There is no output when "OFF" is set.

* This item cannot be set when a CD changer is connected via the CeNET cable.

* The factory default setting is "OFF".

1. Press the [ADJ] button.
2. Press the [◀] or [▶] button to select "D-OUT".
3. Press the [▲] or [▼] button to select "ON" or "OFF".
4. Press the [ADJ] button to return to the previous mode.

Setting the anti-theft indicator (BLINK LED)

This function makes the indicator of Pch6 blink (red) when ACC is OFF to create a visual anti-theft effect.

* The factory default setting is "OFF".

1. Press the [ADJ] button.
2. Press the [◀] or [▶] button to select "BLINK-LED".
3. Press the [▲] or [▼] button to select "ON" or "OFF".
4. Press the [ADJ] button to return to the previous mode.

Setting the beep tone during button operation (BEEP)

A high-pitched beep tone is emitted when you operate a button. This beep output can be disabled.

* The factory default setting is "ON".

1. Press the [ADJ] button.
2. Press the [◀] or [▶] button to select "BEEP".
3. Press the [▲] or [▼] button to select "ON" or "OFF".
4. Press the [ADJ] button to return to the previous mode.

7. OPERATIONS OF ACCESSORIES

CD Changer Operations

CD changer functions

When an optional CD changer is connected through the CeNET cable, this unit controls all CD changer functions. This unit can control a total of 2 changers.

Press the [FUNC] button and select the CD changer mode to start play. If 2 CD changers are connected, press the [FUNC] button to select the CD changer for play.

* If "NO MAG" appears in the display, insert the magazine into the CD changer. "DISC CHK" appears in the display while the player loads (checks) the magazine.

* If "NO DISC" appears in the display, eject the magazine and insert discs into each slot. Then, reinsert the magazine back into the CD changer.

Note:

- Some CDs recorded in CD-R/CD-RW mode may not be usable.

CAUTION

CD-ROM discs cannot be played from every CD changer, it depends on the model.

Pausing play

1. Press the [▶/II] button to pause play. "PAUSE" appears in the display.
2. To resume play, press the [▶/II] button again.

Displaying CD titles

This unit can display title data for CD-text CDs and user titles input with this unit.

* Title data for CD-text CDs can be displayed with this unit only when it is connected to CDC655Tz.

● When connected to DCZ625 or CDC1255z.

Press the [DISP] button to display the title.

● When connected to CDC655Tz

1. Press the [DISP] button to display the title.
2. Each time you press and hold the [DISP] button for 1 second or longer, the title display changes in the following order:
CD-text title (disc) → Artist name → CD-text title (track) ...

Notes:

- If the CD playing is not a CD-text CD or no user title has been input, "NO TITLE" appears in the display.
- If a CD-text CD is not input its disc title or a track title, "NO TITLE" appears in the display.

Procedure to scroll a title

1. Press and hold the [ADJ] button for 1 second or longer.
2. The title is scrolled.

Selecting a CD

1. Press the [UP] or [DOWN] button to select the desired disc.
 - * If a CD is not loaded in a slot of magazine, pressing the [UP] or [DOWN] button can not work.

Selecting a track**● Track-up**

1. Press the [▶▶] button to move ahead to the beginning of the next track.
2. Each time you press the [▶▶] button, the track advances ahead to the beginning of the next track.

● Track-down

1. Press the [◀◀] button to move back to the beginning of the current track.
2. Press the [◀◀] button twice to move to the beginning of the previous track.

Fast-forward/fast-backward**● Fast-forward**

Press and hold the [▶▶] button for 1 second or longer.

● Fast-backward

Press and hold the [◀◀] button for 1 second or longer.

Scan play

Scan play locates and plays the first 10 seconds of each track on a disc automatically. This function continues on the disc until it is cancelled.

* The scan play is useful when you want to select a desired track.

1. Press the [SCN] button to start track scanning. "SCN" lights in the display.
2. To cancel the scan play, press the [SCN] button again. "SCN" goes off from the display and the current track continues to play.

Disc scan play

Disc scan play locates and plays the first 10 seconds of the first track on each disc in the currently selected CD changer. This function continues automatically until it is cancelled.

* Disc scan play is useful when you want to select a desired CD.

1. Press and hold the [SCN] button for 1 second or longer. "DISC" and "SCN" light in the display and disc scan play starts.
2. To cancel disc scan play, press the [SCN] button again. "DISC" and "SCN" go off from the display and the current track continues to play.

Repeat play

Repeat play continuously plays the current track. This function continues automatically until it is cancelled.

1. Press the [RPT] button. "RPT" lights in the display and the current track is repeated.
2. To cancel repeat play, press the [RPT] button again. "RPT" goes off from the display and normal play resumes.

Disc repeat play

After all the tracks on the current disc have been played, disc repeat play automatically replays the current disc over from the first track. This function continues automatically until it is cancelled.

1. Press and hold the [RPT] button for 1 second or longer. "DISC" and "RPT" light in the display and disc repeat play starts.
2. To cancel disc repeat play, press the [RPT] button again. "DISC" and "RPT" go off from the display and normal play resumes on the current track.

Random play

Random play selects and plays individual tracks on the disc in no particular order. This function continues automatically until it is cancelled.

1. Press the [RDM] button. "RDM" lights in the display and random play begins.
2. To cancel random play, press the [RDM] button again. "RDM" goes off from the display and normal play resumes.

Disc random play

The disc random play selects and plays individual tracks or discs automatically in no particular order. This function continues automatically until it is cancelled.

1. Press and hold the [RDM] button for 1 second or longer. "DISC" and "RDM" light in the display and disc random play starts.
2. To cancel disc random play, press the [RDM] button again. "DISC" and "RDM" go off from the display and normal play resumes from the current track.

TV tuner functions

When an optional TV tuner is connected through the CeNET cable, this unit controls all TV tuner functions. To watch a TV, a TV tuner and a monitor are required.

Watching a TV

1. Press the [FUNC] button and select the TV mode.
2. Press the [BAND] button to select the desired TV band (TV1 or TV2). Each time the button is pressed, the input selection toggles between TV1 and TV2.
3. Press the [◀◀] or [▶▶] button to tune in the desired TV station.

Watching a video

The TV tuner has a VTR input terminal to which 1 external device can be connected. Connect a 12 V video cassette player (VCP) or video cassette recorder (VCR) to the TV tuner input terminal.

1. Press the [▶/II] button to select VTR.
2. To return to the TV broadcast, press the [▶/II] button.

Tuning

There are 3 types of tuning mode available, Seek tuning, manual tuning and preset tuning.

Seek tuning

1. Press the [BAND] button and select the desired TV band (TV1 or TV2).
 - * If "MANU" is lit in the display, press and hold the [BAND] button for 1 second or longer. "MANU" in the display goes off and seek tuning is now available.
2. Press the [◀◀] or [▶▶] button to automatically seek a station. Press the [▶▶] button to automatically tune up the frequency band to the next available TV station; press the [◀◀] button to automatically tune down.

Manual tuning

There are 2 ways available: Quick tuning and step tuning.

When you are in the step tuning mode, the frequency changes one step at a time. In the quick tuning mode, you can quickly tune the desired frequency.

1. Press the [BAND] button and select the desired band (TV1 or TV2).
 - * If "MANU" is not lit in the display, press and hold the [BAND] button for 1 second or longer. "MANU" lights in the display and manual tuning is now available.
2. Tune in a station.

● Quick tuning:

Press and hold the [◀◀] or [▶▶] button for 1 second or longer to tune in a station.

● Step tuning:

Press the [◀◀] or [▶▶] button to manually tune in a station.

Recalling a preset station

A total of 12 TV stations can be stored (6-TV1 and 6-TV2). This allows you to select your favorite TV stations and store them in memory for later recall.

1. Press the [BAND] button and select the desired TV band (TV1 or TV2).
2. To recall a stored TV station, press the desired [DIRECT] button to select that station.
 - * Press and hold one of the [DIRECT] buttons for 2 seconds or longer to store the current station into preset memory.

Manual memory

1. Select the desired station with seek tuning, manual tuning or preset tuning.
2. Press and hold one of [DIRECT] buttons for 2 seconds or longer to store the current station into preset memory.

Auto store

Auto store selects 6 TV stations automatically and stores each one into preset memory.

If there are not 6 stations with good reception, stations previously stored in memory remain and only the strong stations are stored into memory.

1. Press the **[BAND]** button and select the desired TV band (TV1 or TV2).
2. Press and hold the **[P/A]** button for 2 seconds or longer. The stations with good reception are stored automatically to the preset channels.

Preset scan

Preset scan allows the user to view each preset position before it automatically advances to the next preset. This function is useful for searching for a desired TV station in memory.

1. Press the **[P/A]** button.
2. When the desired station is found, press the **[P/A]** button again to remain tuned to that station.

Note:

- Do not press and hold the **[P/A]** button for 2 seconds or longer. Doing so will trigger the auto store function and start storing stations into memory.

Setting the TV diversity (TV DIVER)

This function automatically switches to reception by a good-reception antenna during reception of TV broadcasts (when a TV tuner is connected).

* The factory default setting is "ON". Set again to "OFF" when the TV diversity antenna is not in use.

1. Press the **[ADJ]** button.
2. Press the **[◀]** or **[▶]** button to select "TV DIVER".
3. Press the **[▲]** or **[▼]** button to select "ON" or "OFF".
4. Press the **[ADJ]** button to return to the previous mode.

8. IN CASE OF DIFFICULTY

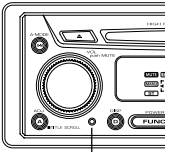
	Problem	Cause	Measure
General	Power does not turn on. (No sound is produced.)	Fuse is blown.	Replace with a fuse of the same amperage. If the fuse blows again, consult your store of purchase.
		Incorrect wiring.	Consult your store of purchase.
	No sound output when operating the unit with amplifiers or power antenna attached.	Power antenna lead is shorted to ground or excessive current is required for remote controlling on the amplifiers or power antenna.	<ol style="list-style-type: none"> 1. Turn the unit off. 2. Remove all wires attached to the power antenna lead. Check each wire for a possible short to ground using an ohm meter. 3. Turn the unit back on. 4. Reconnect each amplifier remote wire to the power antenna lead one by one. If the amplifiers turn off before all wires are attached, use an external relay to provide remote-on voltage (excessive current required).
CD	Nothing happens when buttons are pressed. Display is not accurate.	The microprocessor has malfunctioned due to noise, etc.	Press the reset button for about 2 seconds with a thin rod.  <p style="text-align: center;">Reset button</p>
	Compact disc cannot be loaded.	Another compact disc is already loaded.	Eject the compact disc before loading the new one.
	Sound skips or is noisy.	Compact disc is dirty.	Clean the compact disc with a soft cloth.
		Compact disc is heavily scratched or warped.	Replace with a compact disc with no scratches.
Sound is bad directly after power is turned on.	Water droplets may form on the internal lens when the car is parked in a humid place.	Let dry for about 1 hour with the power on.	
The CD is automatically ejected.	A CD is loaded upside-down inside the CD deck and does not play.	Eject the disc then reload it properly.	

9. ERROR DISPLAYS

If an error occurs, one of the following displays is displayed.
Take the measures described below to eliminate the problem.

	Error Display	Cause	Measure
CD	ERROR 2	A CD is caught inside the CD deck and is not ejected.	This is a failure of CD deck's mechanism. Consult your store of purchase.
	ERROR 3	A CD cannot be played due to scratches, etc.	Replace with a non-scratched, non-warped-disc.
CD changer	ERROR 2	A CD inside the CD changer is not loaded.	This is a failure of CD changer's mechanism. Consult your store of purchase.
	ERROR 3	A CD inside the CD changer cannot be played due to scratches, etc.	Replace with a non-scratched, non-warped disc.
	ERROR 6	A CD inside the CD changer cannot be played because it is loaded upside-down.	Eject the disc then reload it properly.
DVD changer	ERROR 2	A DISC inside the DVD changer cannot be played.	This is a failure of DVD mechanism. Consult your store of purchase.
	ERROR 3	A DISC cannot be played due to scratches, etc.	Retry or replace with a non-scratched, non-warped-disc.
	ERROR 6	A DISC inside the DVD changer cannot be played because it is loaded upside-down.	Eject the disc then reload it properly
	ERROR P	Parental level error	Set the correct Parental level.
	ERROR R	Region code error	Eject the disc and replace correct region code disc.

If an error display other than the ones described above appears, press the reset button. If the problem persists, turn off the power and consult your store of purchase.

10. SPECIFICATIONS

FM Tuner

Frequency Range:
87.9 MHz to 107.9 MHz

Usable Sensitivity:
9 dBf

50dB Quieting Sensitivity:
15 dBf

Alternate Channel Selectivity:
70 dB

Stereo Separation (1 kHz):
35 dB

Frequency Response (± 3 dB):
30 Hz to 15 kHz

AM Tuner

Frequency Range:
530 kHz to 1710 kHz

Usable Sensitivity:
25 μ V

CD Player

System:
Compact disc digital audio system

Usable Discs:
Compact disc

Frequency Response (± 1 dB):
5 Hz to 20 kHz

Signal to Noise Ratio (1 kHz):
112 dB

Dynamic Range (1 kHz):
100 dB

Harmonic Distortion:
0.003% (20Hz to 20kHz)

Audio

Bass Control Action (50 Hz):
 ± 12 dB

Treble Control Action (10 kHz):
 ± 12 dB

Line Output Level (CD 1 kHz):
Vol 0dB = 4V
Vol +6dB = 8V (Max)

DSP/DAC

- A/D conversion: 24-bit 64x oversampling $\Delta\Sigma$ A/D converter
- D/A conversion: 96 kHz/24-bit advanced segment D/A converter
- 8x oversampling digital filter:
Blocked band attenuation: -130 dB
Transmitted band attenuation: ± 0.00001 dB
- Sampling rate converter:
Input sampling rate (fs32k, fs44.1k, fs48k, fs96k)
Output sampling rate (fs48k, fs96k)
- DSP: 24-bit audio DSP, 34-bit arithmetic operation (overflow margin 4-bit)
MULTI mode: 4WAY. X-OVER/
HIGH-HPF 315 Hz to 20 kHz/
MID-LPF 250 Hz to 20 kHz, THROUGH/
LOW-LPF 250 Hz to 10 kHz, THROUGH/
LOW-HPF THROUGH, 25 Hz to 250 Hz/
SUB-W-LPF 25 Hz to 250 Hz, THROUGH/
SUB-W-HPF THROUGH, 16 Hz to 80 Hz
Each fc1/3 oct step SLOPE -6/-12/-18 dB
GAIN 0 to -24 dB
: 5BAND-P.EQ/BAND 1/2/3 50 Hz to 20 kHz
BAND4/5 630 Hz to 20 kHz

Note:

- Specifications and design are subject to change without notice for further improvement.

Each fc1/3 oct step GAIN ± 12 dB Q0.5 to 12
: Time alignment/0 to 512.4 cm 0.7 cm steps

: Tone control/BASS 50 Hz ± 12 dB
TREBLE 10 kHz ± 12 dB

* When BASS/TREB is selected
STANDARD mode: FRONT-2WAY

HIGH-HPF 315 Hz to 20 kHz/
FRONT-LPF 250 Hz to 20 kHz, THROUGH/
REAR-HPF THROUGH, 25 Hz to 250 Hz/
SUB-W-LPF 25 Hz to 250 Hz, THROUGH/
SUB-W-HPF THROUGH, 16 Hz to 80 Hz

Each fc1/3 oct step SLOPE -6/-12/-18 dB
GAIN 0 to -24 dB
5BAND-P.EQ/time alignment/tone control
DIRECT mode: FRONT+REAR+NON-FADER

General

Power Supply Voltage:
14.4 V DC (10.8 to 15.6 V allowable),
negative ground

Current Consumption:
Less than 5 A

Weight / Source unit:
3.96 lb. (1.8 kg)

Weight / DC-DC Converter:
1.541 lb. (700 g)

Weight / Remote control unit:
1.76 oz. (50 g) (including battery)

Dimensions / Source unit:
7" (Width) \times 2" (Height) \times 6-1/8" (Depth)
[178 (W) \times 50 (H) \times 155 (D) mm]

Dimensions / DC-DC Converter:
6-7/10" (Width) \times 1-5/8" (Height) \times 3-7/8" (Depth)
[163 (W) \times 42 (H) \times 98 (D) mm]

Dimensions / Remote control unit:
1-3/4" (Width) \times 4-5/16" (Height) \times 1-1/8" (Depth)
[52 (W) \times 125 (H) \times 12 (D) mm]

MEMO : SOUND SETUP MEMO

Multi Mode

English

English

Standard Mode

			MEMORY1	MEMORY2	MEMORY3		
FILTER	FRONT-HIGH	HPF	Filter frequency(fc)				Hz
			Slope				dB/oct
		Gain					dB
		Phase	NOR/REV	NOR/REV	NOR/REV		
	FRONT-LOW	LPF	Filter frequency(fc)				Hz
			Slope				dB/oct
		Gain					dB
		Phase	NOR/REV	NOR/REV	NOR/REV		
	REAR	HPF	Filter frequency(fc)				Hz
			Slope				dB/oct
		Gain					dB
		Phase	NOR/REV	NOR/REV	NOR/REV		
SUB-W	LPF	Filter frequency(fc)				Hz	
		Slope				dB/oct	
	Gain					dB	
	Phase	NOR/REV	NOR/REV	NOR/REV			

			MEMORY1	MEMORY2	MEMORY3		
X-OVER	HIGH	HPF	Filter frequency(fc)				Hz
			Slope				dB/oct
		Gain					dB
	MID	LPF	Filter frequency(fc)				Hz
			Slope				dB/oct
		Phase	NOR/REV	NOR/REV	NOR/REV		
	LOW	HPF	Filter frequency(fc)				Hz
			Slope				dB/oct
		Gain					dB
	SUB-W	LPF	Filter frequency(fc)				Hz
			Slope				dB/oct
		Phase	NOR/REV	NOR/REV	NOR/REV		

			MEMORY1	MEMORY2	MEMORY3	
TIME Alignment	FRONT-HIGH	Lch				cm
		Rch				cm
	FRONT-LOW	Lch				cm
		Rch				cm
	REAR	Lch				cm
		Rch				cm
	SUB-W	Lch				cm
		Rch				cm

			MEMORY1	MEMORY2	MEMORY3	
TIME Alignment	HIGH	Lch				cm
		Rch				cm
	MID	Lch				cm
		Rch				cm
	LOW	Lch				cm
		Rch				cm
	SUB-W	Lch				cm
		Rch				cm

			MEMORY1	MEMORY2	MEMORY3		
P.EQ	LEFT	BAND1	Center frequency(fo)				Hz
			Gain				dB
			Q				
		BAND2	Center frequency(fo)				Hz
			Gain				dB
			Q				
		BAND3	Center frequency(fo)				Hz
			Gain				dB
			Q				
		BAND4	Center frequency(fo)				Hz
	Gain					dB	
	Q						
	BAND5	Center frequency(fo)				Hz	
		Gain				dB	
		Q					
	RIGHT	BAND1	Center frequency(fo)				Hz
			Gain				dB
			Q				
		BAND2	Center frequency(fo)				Hz
			Gain				dB
Q							
BAND3		Center frequency(fo)				Hz	
		Gain				dB	
		Q					
BAND4		Center frequency(fo)				Hz	
	Gain				dB		
	Q						
BAND5	Center frequency(fo)				Hz		
	Gain				dB		
	Q						

			MEMORY1	MEMORY2	MEMORY3		
P.EQ	LEFT	BAND1	Center frequency(fo)				Hz
			Gain				dB
			Q				
		BAND2	Center frequency(fo)				Hz
			Gain				dB
			Q				
		BAND3	Center frequency(fo)				Hz
			Gain				dB
			Q				
		BAND4	Center frequency(fo)				Hz
	Gain					dB	
	Q						
	BAND5	Center frequency(fo)				Hz	
		Gain				dB	
		Q					
	RIGHT	BAND1	Center frequency(fo)				Hz
			Gain				dB
			Q				
		BAND2	Center frequency(fo)				Hz
			Gain				dB
Q							
BAND3		Center frequency(fo)				Hz	
		Gain				dB	
		Q					
BAND4		Center frequency(fo)				Hz	
	Gain				dB		
	Q						
BAND5	Center frequency(fo)				Hz		
	Gain				dB		
	Q						

Free Manuals Download Website

<http://myh66.com>

<http://usermanuals.us>

<http://www.somanuals.com>

<http://www.4manuals.cc>

<http://www.manual-lib.com>

<http://www.404manual.com>

<http://www.luxmanual.com>

<http://aubethermostatmanual.com>

Golf course search by state

<http://golfingnear.com>

Email search by domain

<http://emailbydomain.com>

Auto manuals search

<http://auto.somanuals.com>

TV manuals search

<http://tv.somanuals.com>