

clarion

APA1100
MONO



CAR AUDIO
AMPLIFIER

OPERATION
INSTALLATION
MANUAL

INTRODUCTION

Thank you for purchasing a Clarion APA1100 mono car audio amplifier. You've selected an amplifier that is one of the finest available on the market today. The APA1100 puts out 100 watts of continuous power into a 4-ohm load and delivers 150 watts (typical) into a 2-ohm load. It also comes with the following features:

- ◆ Full frequency response with low distortion and exceptional signal-to-noise performance
- ◆ Variable low-pass electronic crossover with an 12 dB per octave slope and full adjustment range (from 50 to 200 Hz) to aid in audio system design
- ◆ Variable bass extender circuit to reinforce low frequency signals that may be lost due to box design
- ◆ Auto-mix summing circuit (L+R Mono) to prevent the loss of bass due to differences in left or right input signals
- ◆ Ground loop isolation inputs with adjustable input level controls to accept a wide range of input signals
- ◆ Remote turn-on with "soft-start" muting to prevent turn-on "thump"
- ◆ Regulated MOSFET power supply with low AM RFI and protection circuits for overheating and speaker shorts
- ◆ 2-ohm load capability to drive a variety of speaker systems
- ◆ Gold-plated input/output connectors and an external automotive-type fuse
- ◆ Aluminum heat sink for efficient dissipation of heat
- ◆ Low profile, compact size for space-limited installations

In order to start enjoying your new Clarion APA1100 mono car audio amplifier as soon as possible, please read the remaining pages to plan your installation. When you're finished, fill out and send in the enclosed warranty card to protect your purchase and to aid us in any service-related questions. Also, **save your original bill of sale as a proof of purchase.**

TABLE OF CONTENTS

Description	3
Amplifier Inputs/Controls/Power Indicator	4
Connections for Speakers/Power	5
Applications	6
Single Mono Subwoofer System (4-ohm Load)	6
Dual Mono Subwoofer System (4-ohm Load)	7
Dual Mono Subwoofer System (2-ohm Load)	8
Installation	9
Mounting Precautions	9
Wiring Precautions	9
Setting Gain	12
Adjusting The Low-Pass Filter	13
Adjusting The Bass Extender	13
Final System Checks	14
Troubleshooting	14
Everyone Wants "More Bass"	16
Specifications	17

DESCRIPTION

The Clarion APA1100 mono car audio amplifier (shown in Figure 1) provides 100 watts of rms power into a 4-ohm load and 150 watts (typical) into a 2-ohm load. This full-featured model is an excellent choice for configuring a variety of car audio sound systems.

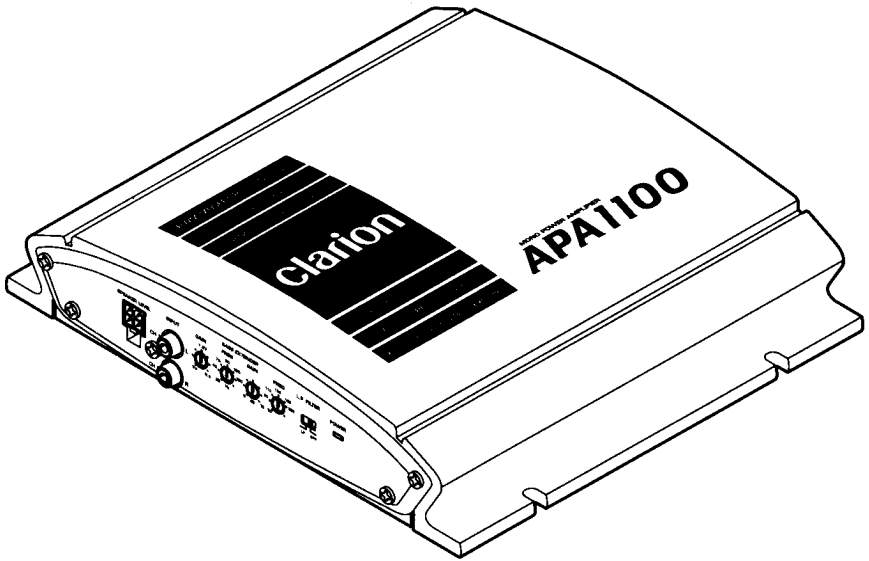

Figure 1. Clarion APA1100 mono car audio amplifier.

The APA1100 uses a regulated MOSFET power supply for superior control of output wattage, regardless of input voltage or musical energy content. MOSFETs are chosen for their inherent characteristics to provide superior accuracy, stability, and control. A toroid-coil transformer yields maximum power transfer with minimum heat loss. Careful attention to circuit design keeps AM RFI at low levels, so you won't hear unwanted noise when the level is cranked up. Protection circuits safeguard the amplifier when overheating and speaker shorts or improper load conditions occur.

All connections and controls are on end panels and are straightforward and easy to understand. We use gold-plated RCA and barrier connectors to ensure the best electrical connection for your system. Included is an external automotive-type fuse that is easy to replace.

Amplifier Inputs/Controls/Power Indicator

The APA1100's front panel (see Figure 2) has dual speaker-level input connections, dual-RCA input jacks, GAIN, BASS EXTENDER, and FILTER controls, and a POWER indicator.

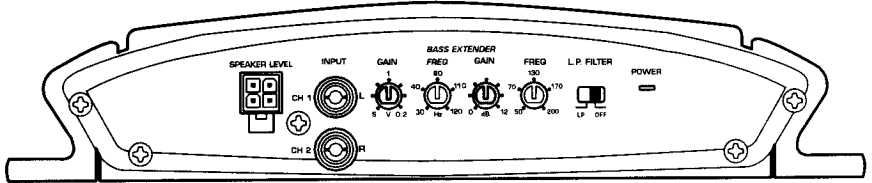

Figure 2. Front panel layout of the Clarion APA1100.

Low-Level/Speaker-Level Summed (L+R) Inputs

Gold-plated RCA input jacks, labeled CH 1 (L) and CH 2 (R), provide connections for a low-level stereo source. Speaker-level connections are provided for installations where the source unit's RCA outputs are unavailable (see *Specifications* on page 17 for wire codes). An internal summing circuit electronically adds the stereo audio (present on inputs 1 and 2) to create a true mono signal (L+R) at the input stage. This helps prevent signal loss when you adjust the balance and also insures constant bass, no matter what audio information is contained in the individual left or right stereo channels.

Gain Control

The GAIN control lets you set the amplifier's nominal operating level. The wide range, 200 mV to 5 V for RCA inputs or 400 mV to 10 V for speaker-level inputs, can handle input levels from virtually any brand of source unit.

Bass Extender Control

The APA1100's "high-Q" (i.e., narrow frequency band) BASS EXTENDER circuit has full-adjustable GAIN and FREQ (frequency) controls. It acts much like an equalizer, so you can adjust gain from 0 to +12 dB at any frequency between 30 and 120 Hz (using the FREQ control). Use it to precisely tune low-frequency audio response to compensate for a less-than-ideal subwoofer enclosure design. The added boost produces rich, full bass tones that are normally difficult to reproduce in the car audio environment.

Filter Controls

The APA1100 has a 12 dB per octave electronic low-pass filter for precise frequency attenuation with minimal phase distortion. The steep crossover slope keeps midrange tones out of the subwoofer, eliminating unnatural “nasal” tone quality in the audio system. The filter is fully adjustable between 50 and 200 Hz for a wide range of crossover points. Use this feature, along with your speaker manufacturer’s recommended crossover frequencies, to quickly design a more advanced system (see *Applications* starting on page 6). Slide the LP FILTER switch to LP to activate the low-pass filter. Set the FREQ (frequency) control anywhere between 50 to 200 Hz. If your system design doesn’t call for a crossover filter, simply leave the LP FILTER switch in the OFF position.

NOTE: If the LP FILTER switch is set to OFF, varying its FREQ control will produce no effect.

Connections for Speakers/Power

The APA1100’s rear panel (see Figure 3) contains speaker and power connections and an external fuse.

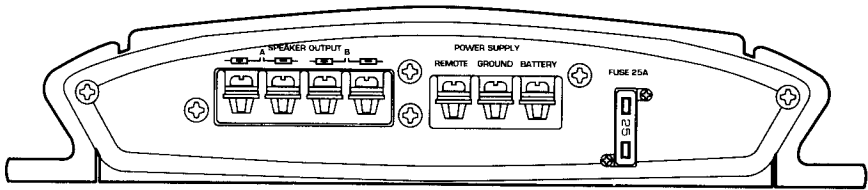

Figure 3. Rear panel layout of the Clarion APA1100.

Speaker Connections

The speaker terminals are gold-plated terminals with polarity markings for A and B (mono) speaker connections.

Power Connections

The power connections are also gold-plated and are labeled REMOTE (for remote turn-on via source unit), GROUND, and BATTERY (+12 Vdc). An automotive-type 25 A fuse protects the amplifier circuit.

APPLICATIONS

The Clarion APA1100 mono car audio amplifier can be used in a variety of system applications. Here are three examples to help plan your own installation (see Figures 4 through 6).

Single Mono Subwoofer System **4-ohm Load – 200 Watts (rms)**

(Use "L" or "R" input or use both inputs for true L+R MONO signal)

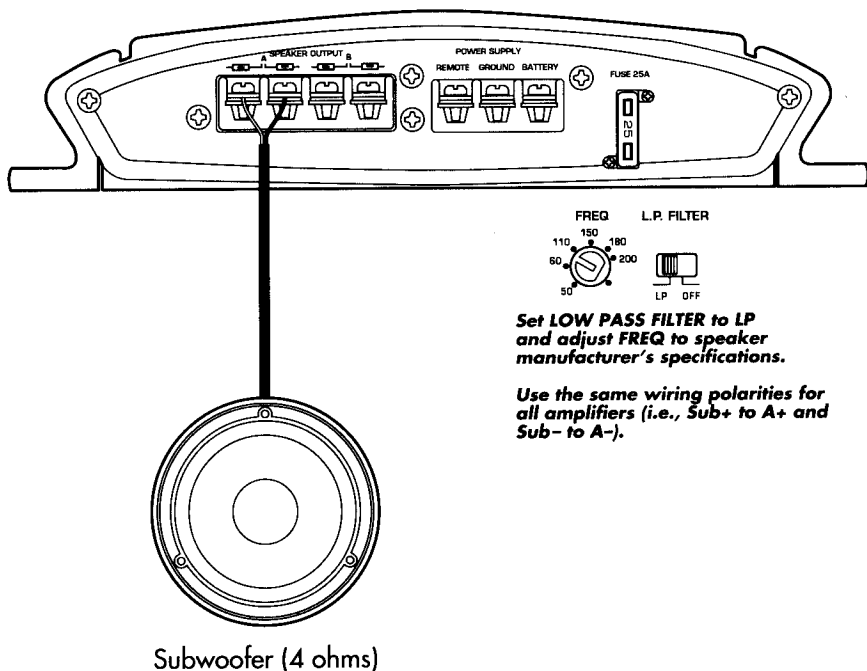

Set LOW PASS FILTER to LP and adjust FREQ to speaker manufacturer's specifications.

Use the same wiring polarities for all amplifiers (i.e., Sub+ to A+ and Sub- to A-).

Figure 4. In this application, an APA1100 drives a single 4-ohm subwoofer with 100 watts of continuous average power.

Dual Mono Subwoofer System

4-ohm Load - 200 Watts (rms)

(Use "L" or "R" input or use both inputs for true L+R MONO signal)

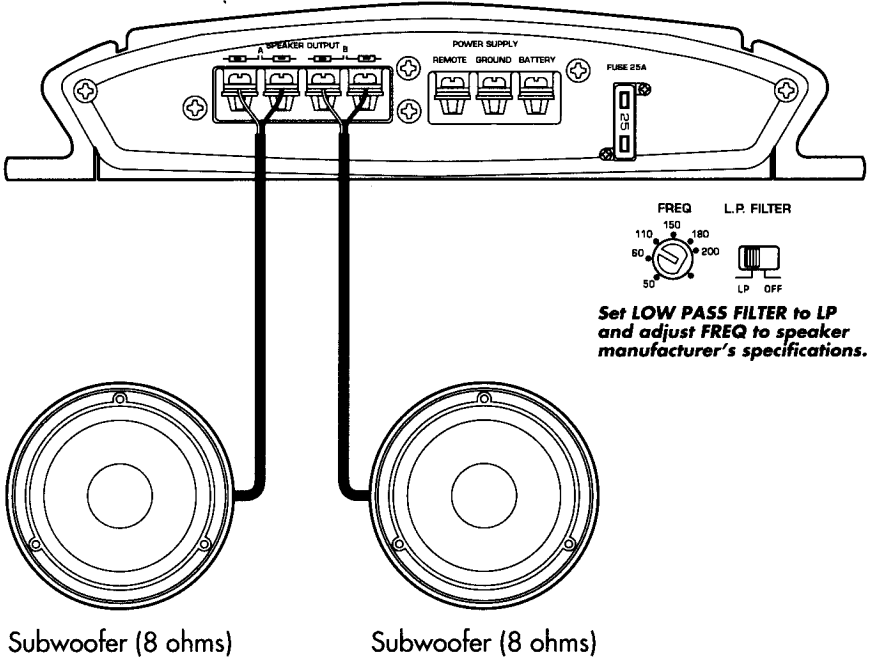

Figure 5. In this application, an APA 1100 drives two 8-ohm subwoofers at 100 watts of continuous average power.

Dual Mono Subwoofer System

2-ohm Load – 300 Watts (rms)

(Use "L" or "R" input or use both inputs for true L+R MONO signal)

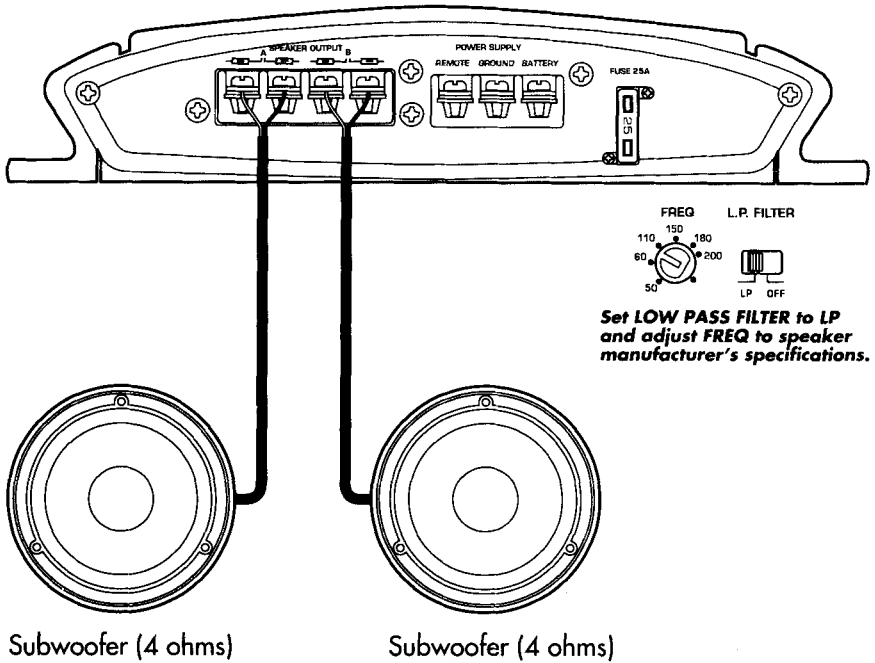

Figure 6. In this application, an APA1100 drives two 4-ohm subwoofers at 150 watts of continuous average power.

NOTE: Power supply heat dissipation doubles with 2-ohm loading. Make sure there is sufficient air circulation around the amplifier; otherwise excessive heat may damage the unit.

INSTALLATION

This section lists mounting and wiring precautions for installing a Clarion APA1100 mono car audio amplifier. Combined with the experience of a professional installer, these safeguards provide enough detail to successfully complete an installation. If you do not have the necessary skills, do not install the amplifier yourself. Instead, see your authorized Clarion dealer for installation recommendations.

Mounting Precautions

Although the Clarion APA1100 mono car audio amplifier incorporates electronic protection circuits, mounting any amplifier in a confined space without any air movement can still damage internal circuits over time. Choose a site that provides adequate ventilation around the amplifier. For easy system set-up, mount the amplifier so the controls and fuse will be accessible after installation.

In addition, observe these precautions:

- ◆ For the most efficient cooling, mount the amplifier so cool air runs along the length of the heatsink, rather than across it. Remember, any moving air across the heatsink surface will dissipate heat.
- ◆ Mount the amplifier on a rigid surface inside the vehicle. Do not install the amplifier on plastic or other combustible materials.
- ◆ Prior to drilling, make sure proposed mounting holes will not cut into the fuel tank, fuel lines, brake lines (under chassis), or electrical wiring.

Wiring Precautions

- ◆ Read all wiring precautions. If you are not sure of the connections, contact your authorized Clarion dealer.
- ◆ Before installation, make sure the source unit power switch is in the OFF position.
- ◆ Disconnect the negative (-) lead at the battery before making any power connections.

- ◆ When making connections, be sure that each connection is clean and secure. Insulate final connections with electrical tape or shrink tubing. Failure to do so may damage your equipment.
- ◆ A secure, clean ground connection is critical to the performance of your Clarion car audio amplifier. Use the shortest ground wire possible to minimize resistance and avoid noise problems.
- ◆ Refer to Figure 7 when making electrical connections. Connect the amplifier's positive (+) power lead via a fuse directly to the positive (+) terminal on the battery. Do not connect this wire to the car's fuse panel. Use the power cable calculator chart (see Figure 8 on page 12) to determine the appropriate wire size for the amplifier's positive (+) power lead and the same-gauge black-insulated wire for the ground.

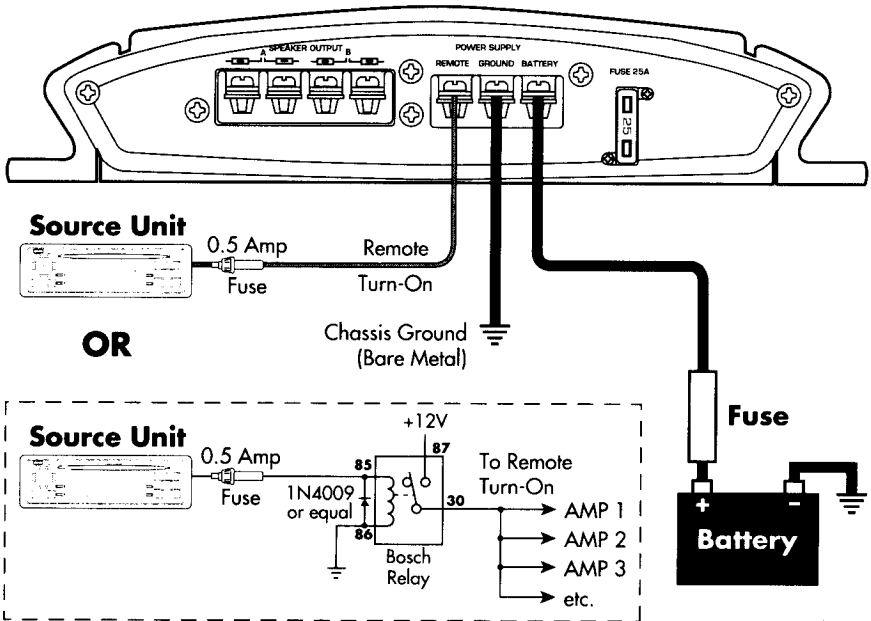

Caution: Clarion's Antenna/Amp output is restricted to 500 mA (MAXIMUM). Do not replace the 0.5 A fuse with a higher value or you will damage the unit. If more current is required when installing multiple amplifiers, use this relay circuit.

Figure 7. Electrical connections for an APA1100 amplifier.

- ◆ Add an external fuse on the positive (+) power lead and connect it as close as possible to the vehicle's (+) battery terminal. Use a rating that equals the total current consumption at full output of all amplifiers in the system. Adding an external fuse will protect the electrical system from short circuits that can cause a fire.
- ◆ When replacing the amplifier's fuse, always use one having the same current rating. Substituting a higher-rated fuse can reduce protection and may result in serious damage to the amplifier.
- ◆ Never ground the speakers to the vehicle chassis or body.
- ◆ Make sure that your vehicle's electrical system (i.e., alternator, battery, etc.) is capable of handling the additional load. If you are planning a multi-amplifier system, you may need to add a second battery and possibly upgrade the alternator with a higher-output-rated model. Consult your authorized Clarion dealer for recommendations.
- ◆ To avoid possible noise problems, run the amplifier's positive (+) power lead along one side of the vehicle to the battery. Run the remote turn-on wire and RCA audio cables down the center, and route the speaker wires along the remaining side. If wires must cross, run them perpendicular to each other.
- ◆ When creating passage holes for the power wire, use grommets to eliminate any sharp edges created during drilling. This will protect the wire from being nicked and causing a short circuit.
- ◆ Extra cable can cause signal loss and act as an "antenna" for noise. Use only high-quality RCA cables that are no longer than necessary to make a direct connection with the source unit or equalizer.
- ◆ Depending on the type of system being installed, refer to the examples in Figures 4 through 6 (starting on page 6) for information on wiring and setting the operation mode.

Power Cable Calculator

Total System Amperage Draw	Cable 0' - 4'	Cable 4' - 7'	Cable 7' - 10'	Cable 10' - 13'	Cable 13' - 16'	Cable 16' - 19'	Cable 19' - 22'	Cable 22' - 28'
0 - 20 amperes	14	12	12	10	10	8	8	8
20 - 35 amperes	12	10	8	8	6	6	6	4
35 - 50 amperes	10	8	8	6	6	4	4	4
50 - 65 amperes	8	8	6	4	4	4	4	2
65 - 85 amperes	6	6	4	4	2	2	2	0
85 - 105 amperes	6	6	4	2	2	2	2	0
105 - 125 amperes	4	4	4	2	2	0	0	0
125- 150 amperes	2	2	2	2	0	0	0	00

Figure 8. Use this chart to find a copper-wire gauge that will exhibit no more than a 0.5 volt drop for a desired cable length. If aluminum or tinned wire is used, select an even larger gauge size to compensate for material difference. NOTE: Cable-size calculations take into account terminal connection resistance.

SETTING GAIN

After completing the installation, follow these steps to set the amplifier's GAIN control:

1. Turn input GAIN and Bass Extender's GAIN controls full left to their minimum positions.
2. Turn the vehicle's ignition switch to the ON position. Then turn on the source unit. Set all tone or equalization controls to "flat" positions and turn loudness off.
3. Play a CD or tape and set the volume control at 75% of full level.
4. Verify that the POWER indicator on the amplifier comes on.

NOTE: When using an equalizer, set its frequency controls to "flat."

5. If appropriate, set the fader control (on the source unit) to feed the amplifier at full level. Slowly increase the input GAIN. Stop when you hear a slight distortion of audio.

ADJUSTING THE LOW-PASS FILTER

NOTE: Clarion recommends turning the amplifier off before changing any switch position to eliminate any possible damage from transient spikes to the amplifier or speaker system.

1. When connecting the amplifier to a subwoofer driver, slide the LP FILTER switch to the LP position. (In the OFF position, full frequency audio signals will pass through the amplifier to the speaker).
2. Set the FREQ control set to 50 Hz (i.e., full left) or to the recommended crossover point from the speaker manufacturer.
3. Listen to a variety of music styles (Rock, Rap, R&B, etc.) and slowly increase or decrease the FREQ control until the best performance of the subwoofer is realized.

NOTE: For most subwoofer systems, the crossover point will be between 50 and 200 Hz. Setting it too high may cause the audio system to sound “boomy” or vocals and speech to become very “nasal” in tone.

ADJUSTING THE BASS EXTENDER

NOTE: Clarion recommends setting the frequency of the low-pass filter before attempting to adjust bass response with the Bass Extender controls.

1. Initially set the Bass Extender’s FREQ control to its full right position (i.e., 120 Hz) and its GAIN control to its middle position (i.e., +6 dB).
2. Listen to a variety of music styles (e.g., Rock, Rap, R&B, etc.) and slowly decrease the FREQ control until no noticeable increase in low bass response is perceived.
3. Slowly adjust the Bass Extender’s GAIN control (up or down) to realize the best low bass response.

CAUTION: If the subwoofer begins to “pop” (due to over-excursion), lower the GAIN control or raise the FREQ control to prevent speaker damage. If the subwoofer begins to sound muddy and distorted (due to amplifier clipping), lower the GAIN control to avoid shutdown from overheating or raise the FREQ control until clear bass response returns.

FINAL SYSTEM CHECKS

1. Start the engine and turn on the source unit. After a two-second delay, slowly increase the volume control and listen to the audio. If you hear any noise, static, distortion, or no sound at all, check the connections, and also refer to *Troubleshooting*. Depending on your system, the levels may be quite loud even at low volume settings. Until you get an “audio feel” of the system’s power, use care when adjusting controls.
2. Vary the balance control from left to right and listen to the results. Bass levels should not vary if the amplifier is configured using both L and R audio inputs.
3. Increase the volume and verify that the amplifier reproduces audio without distortion. If you hear distortion, check the connections and verify that the GAIN and BASS EXTENDER controls are set correctly. Another possibility is damaged (or under-powered) speakers. Once again, refer to *Troubleshooting* for additional help.

TROUBLESHOOTING

Symptom	Cause	Solution
No audio	Low or no remote turn-on voltage	Check REMOTE wiring or add relay circuit if source unit fuse continues to blow
	Blown amplifier fuse	Replace with new fast-blow fuse (same rating)
	Power wires not connected	Check BATTERY and GROUND wiring at amplifier; check battery connections
	Speaker leads shorted	Check speaker continuity to ground; should not show a common ground

Symptom	Cause	Solution
No audio	Low or no remote Speakers not connected or are blown	Check REMOTE wiring Check speaker connections at amplifier; measure coil impedance
Audio cycles on and off	Thermal protection circuits are shutting amplifier off	Check location for adequate ventilation; consult an authorized Clarion dealer
Distorted audio	Gain is not set properly, or damaged speaker cones	Review <i>Setting Gain</i> on page 12; inspect each speaker cone for signs of damage (e.g., frozen cone, burning smell, etc.)
Audio lacks punch	Speakers wired incorrectly, which causes cancellation of bass frequencies	Check polarity of wires from amplifier to each speaker as defined by the system design
Amplifier fuse keeps blowing	Incorrect wiring or short circuit	Review <i>Installation</i> on pages 9 ~ 11; check all wiring connections
Whining or ticking noise in the audio with engine on	Amplifier is picking up alternator noise or radiated noise	Check power and ground connections on amplifier; check or move audio cables; install an in-line noise filter on source unit's power wire; check alternator and/or voltage regulator; test for weak battery or add water to battery

EVERYONE WANTS "MORE BASS"

In the car audio environment, subsonic bass information (often called "thump") requires three sizable components:

1. Speaker Piston Area (the size of the moving surface)
2. Cone Excursion (the amount of surface travel)
3. Power (the ability to move the surface)

In a home, bass is easily propagated (i.e., reproduce one complete cycle of an audio signal), whereas in a small vehicle, "air pressure" must be modulated to simulate propagation of the bass wave. Speaker piston area and cone excursion become the critical factors in producing low-frequency response.

As a general rule of thumb, remember that the smaller the speaker, the greater the mechanical cone travel required to produce low bass. The larger the speaker, the shorter the mechanical cone travel required to produce the same bass response.

A single subwoofer can only produce as much "pressure" as the piston area and the amount of mechanical cone excursion allow. Throwing more power on a single subwoofer may not be the best answer to more bass response. Adding multiple subwoofers to an audio system is often more economical than adding sheer brute amplifier power.

The best answer may be a combination of factors, including larger speakers, multiple drivers, and bigger amplifiers. This may require modification of the car's electrical system, or special installation skills necessary to design and install multiple subwoofer speaker systems. Just how much bass is enough?

Everyone wants "more **BASS**" in the car audio environment. If this is your goal, we suggest visiting your local authorized Clarion dealer for professional system designs and installation options.

Free Manuals Download Website

<http://myh66.com>

<http://usermanuals.us>

<http://www.somanuals.com>

<http://www.4manuals.cc>

<http://www.manual-lib.com>

<http://www.404manual.com>

<http://www.luxmanual.com>

<http://aubethermostatmanual.com>

Golf course search by state

<http://golfingnear.com>

Email search by domain

<http://emailbydomain.com>

Auto manuals search

<http://auto.somanuals.com>

TV manuals search

<http://tv.somanuals.com>