

SERVICE MANUAL

M660SE / M665SE

notebook

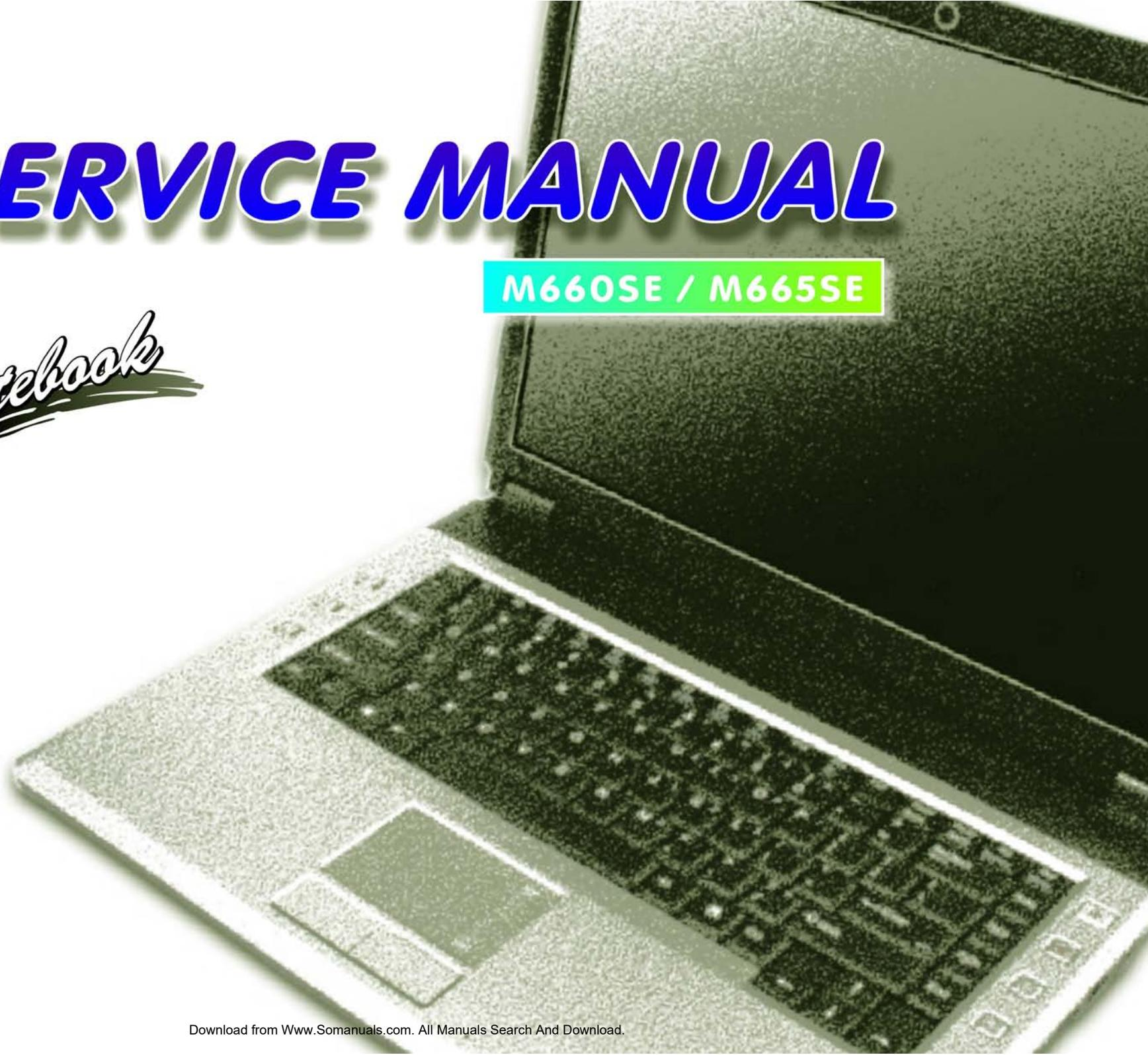

Notebook Computer

M660SE/M665SE

Service Manual

Notice

The company reserves the right to revise this publication or to change its contents without notice. Information contained herein is for reference only and does not constitute a commitment on the part of the manufacturer or any subsequent vendor. They assume no responsibility or liability for any errors or inaccuracies that may appear in this publication nor are they in anyway responsible for any loss or damage resulting from the use (or misuse) of this publication.

This publication and any accompanying software may not, in whole or in part, be reproduced, translated, transmitted or reduced to any machine readable form without prior consent from the vendor, manufacturer or creators of this publication, except for copies kept by the user for backup purposes.

Brand and product names mentioned in this publication may or may not be copyrights and/or registered trademarks of their respective companies. They are mentioned for identification purposes only and are not intended as an endorsement of that product or its manufacturer.

Version 1.0
February 2007

Trademarks

Intel, **Celeron**, and **Intel Core** are trademarks/registered trademarks of Intel Corporation.

Windows® is a registered trademark of Microsoft Corporation.

Other brand and product names are trademarks and./or registered trademarks of their respective companies.

About this Manual

This manual is intended for service personnel who have completed sufficient training to undertake the maintenance and inspection of personal computers.

It is organized to allow you to look up basic information for servicing and/or upgrading components of the *M660SE/M665SE* series notebook PC.

The following information is included:

Chapter 1, Introduction, provides general information about the location of system elements and their specifications.
Chapter 2, Disassembly, provides step-by-step instructions for disassembling parts and subsystems and how to upgrade elements of the system.

Appendix A, Part Lists

Appendix B, Schematic Diagrams

IMPORTANT SAFETY INSTRUCTIONS

Follow basic safety precautions, including those listed below, to reduce the risk of fire, electric shock and injury to persons when using any electrical equipment:

1. Do not use this product near water, for example near a bath tub, wash bowl, kitchen sink or laundry tub, in a wet basement or near a swimming pool.
2. Avoid using a telephone (other than a cordless type) during an electrical storm. There may be a remote risk of electrical shock from lightning.
3. Do not use the telephone to report a gas leak in the vicinity of the leak.
4. Use only the power cord and batteries indicated in this manual. Do not dispose of batteries in a fire. They may explode. Check with local codes for possible special disposal instructions.
5. This product is intended to be supplied by a Listed Power Unit (DC Output 19V, 3.42A or 18.5, 3.5A AC/DC Adapter).

CAUTION

Always disconnect all telephone lines from the wall outlet before servicing or disassembling this equipment.

**TO REDUCE THE RISK OF FIRE, USE ONLY NO. 26 AWG OR LARGER,
TELECOMMUNICATION LINE CORD**

This Computer's Optical Device is a Laser Class 1 Product

Instructions for Care and Operation

The notebook computer is quite rugged, but it can be damaged. To prevent this, follow these suggestions:

1. **Don't drop it, or expose it to shock.** If the computer falls, the case and the components could be damaged.



2. **Keep it dry, and don't overheat it.** Keep the computer and power supply away from any kind of heating element. This is an electrical appliance. If water or any other liquid gets into it, the computer could be badly damaged.

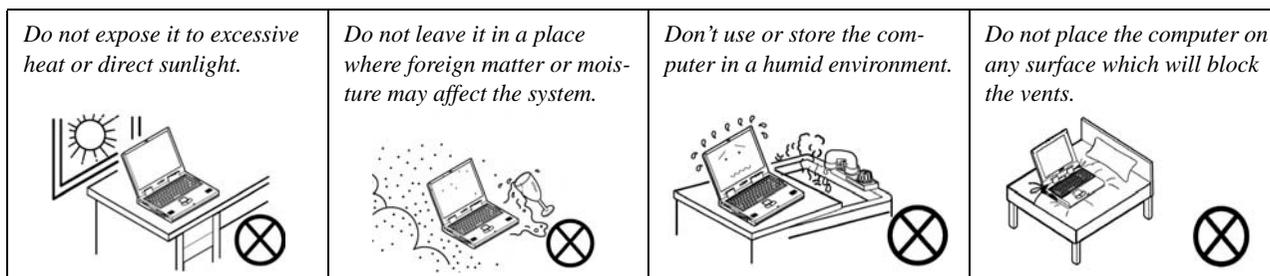

3. **Follow the proper working procedures for the computer.** Shut the computer down properly and don't forget to save your work. Remember to periodically save your data as data may be lost if the battery is depleted.

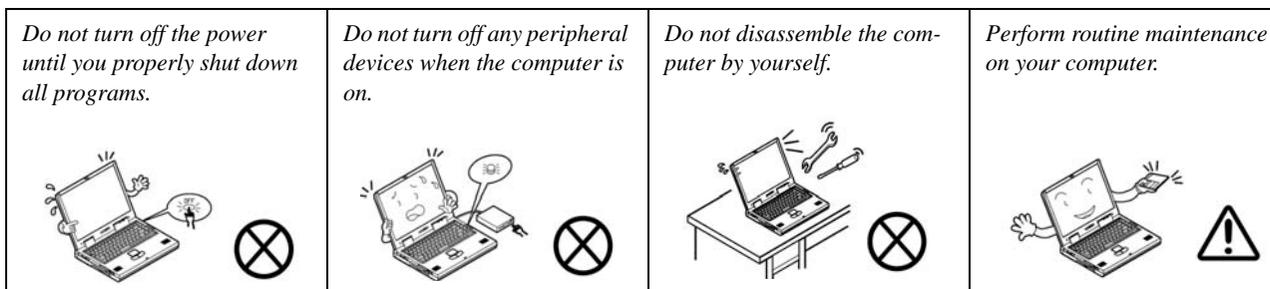

4. **Avoid interference.** Keep the computer away from high capacity transformers, electric motors, and other strong magnetic fields. These can hinder proper performance and damage your data.
5. **Take care when using peripheral devices.**

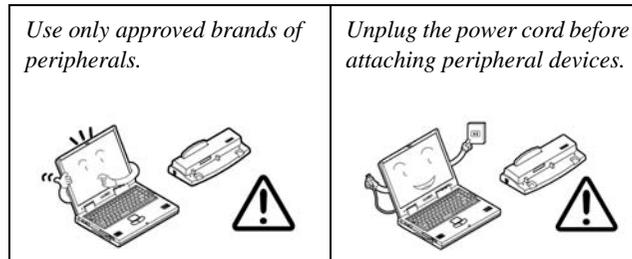

Power Safety

The computer has specific power requirements:

- Only use a power adapter approved for use with this computer.
- Your AC adapter may be designed for international travel but it still requires a steady, uninterrupted power supply. If you are unsure of your local power specifications, consult your service representative or local power company.
- The power adapter may have either a 2-prong or a 3-prong grounded plug. The third prong is an important safety feature; do not defeat its purpose. If you do not have access to a compatible outlet, have a qualified electrician install one.
- When you want to unplug the power cord, be sure to disconnect it by the plug head, not by its wire.
- Make sure the socket and any extension cord(s) you use can support the total current load of all the connected devices.
- Before cleaning the computer, make sure it is disconnected from any external power supplies.

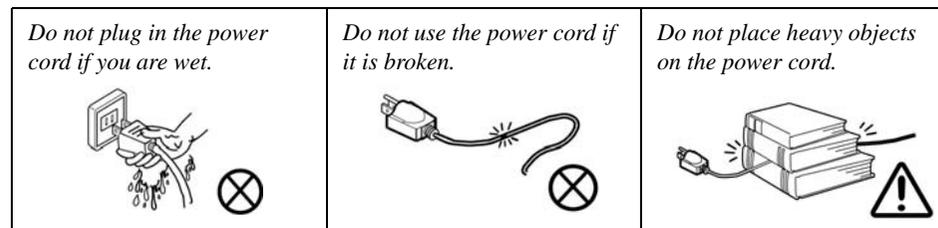

Power Safety Warning

Before you undertake any upgrade procedures, make sure that you have turned off the power, and disconnected all peripherals and cables (including telephone lines). It is advisable to also remove your battery in order to prevent accidentally turning the machine on.

Battery Precautions

- Only use batteries designed for this computer. The wrong battery type may explode, leak or damage the computer.
- Do not continue to use a battery that has been dropped, or that appears damaged (e.g. bent or twisted) in any way. Even if the computer continues to work with a damaged battery in place, it may cause circuit damage, which may possibly result in fire.
- Recharge the batteries using the notebook's system. Incorrect recharging may make the battery explode.
- Do not try to repair a battery pack. Refer any battery pack repair or replacement to your service representative or qualified service personnel.
- Keep children away from, and promptly dispose of a damaged battery. Always dispose of batteries carefully. Batteries may explode or leak if exposed to fire, or improperly handled or discarded.
- Keep the battery away from metal appliances.
- Affix tape to the battery contacts before disposing of the battery.
- Do not touch the battery contacts with your hands or metal objects.



Battery Disposal

The product that you have purchased contains a rechargeable battery. The battery is recyclable. At the end of its useful life, under various state and local laws, it may be illegal to dispose of this battery into the municipal waste stream. Check with your local solid waste officials for details in your area for recycling options or proper disposal.

Caution

Danger of explosion if battery is incorrectly replaced. Replace only with the same or equivalent type recommended by the manufacturer. Discard used battery according to the manufacturer's instructions.

Related Documents

You may also need to consult the following manual for additional information:

User's Manual on CD

This describes the notebook PC's features and the procedures for operating the computer and its ROM-based setup program. It also describes the installation and operation of the utility programs provided with the notebook PC.

Contents

Introduction1-1

Overview	1-1
System Specifications	1-2
Model Differences	1-5
External Locator - Top View with LCD Panel Open	1-6
External Locator - Front & Rear Views	1-7
External Locator - Left & Right Side Views	1-8
External Locator - Bottom View	1-9
M660SE Mainboard Overview - Top (Key Parts)	1-10
M660SE Mainboard Overview - Bottom (Key Parts)	1-11
M660SE Mainboard Overview - Top (Connectors)	1-12
M660SE Mainboard Overview - Bottom (Connectors)	1-13

Disassembly2-1

Overview	2-1
Maintenance Tools	2-2
Connections	2-2
Maintenance Precautions	2-3
Removing the Battery	2-5
Removing the Hard Disk Drive	2-6
Removing the System Memory (RAM)	2-8
Removing the Processor	2-10
Removing the Wireless LAN Module	2-12
Removing the Modem	2-13
Removing the Bluetooth Module	2-14
Removing the Optical (CD/DVD) Device	2-15
Removing the Keyboard	2-16

Part ListsA-1

Part List Illustration Location	A-2
Top (M660SE)	A-3

Top (M665SE)	A-4
Bottom (M660SE/M665SE)	A-5
LCD (M660SE/M665SE)	A-6
CDRW (M660SE/M665SE)	A-7
Combo (M660SE/M665SE)	A-8
DVD RW (M660SE/M665SE)	A-9

Schematic Diagrams.....B-1

SYSTEM BLOCK DIAGRAM	B-2
CLOCK GENERATOR	B-3
CPU-1	B-4
CPU-2	B-5
VN896-1	B-6
VN896-2	B-7
VN896-3	B-8
VN896-4	B-9
DDR2-1	B-10
DDR2-2	B-11
VGA G72M-1	B-12
VGA G72M-2	B-13
VGA G72M-3	B-14
VGA G72M-4	B-15
VT8237A-1	B-16
VT8237A-2	B-17
VT8237A-3	B-18
HDD & CDROM	B-19
CARD READER	B-20
NEW CARD SOCKET	B-21
LAN	B-22
USB & CCD	B-23
HITACHI H8	B-24

Preface

CRT & LVDS	B-25
CPU FAN, LPC ROM	B-26
MINI-PCI & BLUETOOTH	B-27
AUDIO VT1708A/ALC883	B-28
LED	B-29
CHARGER, DC IN	B-30
1.05VS, 1.5V, 2.5VS	B-31
VCORE	B-32
1.8V, 0.9VS	B-33
VDD3, VDD5	B-34
EXT GPU 1.0VS/1.2VS	B-35
HOTKEY LT BOARD	B-36
PWR HOT BOARD	B-37
AUDIO & MODEM BOARD	B-38
CLICK BOARD	B-39
USB BOARD	B-40
FINGERPRINT BOARD	B-41

Chapter 1: Introduction

Overview

This manual covers the information you need to service or upgrade the *M660SE/M665SE* series notebook computer. Information about operating the computer (e.g. getting started, and the *Setup* utility) is in the *User's Manual*. Information about drivers (e.g. VGA & audio) is also found in *User's Manual*. That manual is shipped with the computer.

Operating systems (e.g. *Windows XP*, *Windows Vista*, etc.) have their own manuals as do application software (e.g. word processing and database programs). If you have questions about those programs, you should consult those manuals.

The *M660SE/M665SE* series notebook is designed to be upgradeable. See “*Disassembly*” on page 2 - 1 for a detailed description of the upgrade procedures for each specific component. Please note the warning and safety information indicated by the “” symbol.

The balance of this chapter reviews the computer's technical specifications and features.

System Specifications



Latest Specification Information

The specifications listed in this Appendix are correct at the time of going to press. Certain items (particularly processor types/speeds and CD/DVD device types) may be changed, delayed or updated due to the manufacturer's release schedule. Check with your service center for details.

Feature	Specification
Processor	Intel® Core™2 Duo Processor (478-pin) Micro-FC-PGA Package T7200/ T7400/ T7600 65nm (65 Nanometer) Process Technology 4MB On-die L2 Cache & 667MHz FSB 2.0/ 2.16/ 2.33 GHz
	Intel® Core™2 Duo Processor (478-pin) Micro-FC-PGA Package T5500/ T5600 65nm (65 Nanometer) Process Technology 2MB On-die L2 Cache & 667MHz FSB 1.66/ 1.83 GHz
	Intel® Core™ Duo Processor (478-pin) Micro-FC-PGA Package T2300/ T2400/ T2500/ T2600/ T2700 65nm (65 Nanometer) Process Technology 2MB On-die L2 Cache & 667MHz FSB 1.66/ 1.83/ 2.0/ 2.16/ 2.33 GHz
	Intel® Core™ Solo Processor (478-pin) Micro-FC-PGA Package T1300/ T1400 65nm (65 Nanometer) Process Technology 2MB On-die L2 Cache & 667MHz FSB 1.66/ 1.83 GHz
	Intel® Celeron® M Processor (478-pin) Micro-FCPGA Package 410/ 420/ 430/ 440/ 450 65nm (65 Nanometer) Process Technology 1MB On-die L2 Cache & 533MHz FSB 1.46/ 1.60/ 1.73/ 1.86/ 2.0 GHz
Core Logic	VIA VN896 + VT8237A Chipset
Memory	Two 200 Pin SO-DIMM Sockets Supporting DDRII (DDR2) 533/667 MHz 64-bit Wide DDRII (DDR2) Data Per Channel Memory Expandable up to 2GB (256/ 512/ 1024 MB DDRII Modules)

Feature	Specification	
Security	Security (Kensington® Type) Lock Slot	BIOS Password
BIOS	One 4Mb Flash ROM	Phoenix™ BIOS
LCD	15.4" WXGA (1280 * 800) TFT LCD	
Video Adapter	VIA VN896 Integrated Video System (Internal On Chip) Chrome 9HC™ Integrated 128bit 2D/3D Graphic Engine and Clock up to 250MHz Supports CRT Resolutions up to 2048 * 1536 at 75Hz Supports Microsoft DirectX 9.0	
Storage	One Changeable 12.7mm(h) Optical Device (CD/DVD) Type Drive One Easy Changeable 2.5" 9.5 mm (h) SATA (Serial) HDD	
Audio	Integrated AZALIA Compliant Interface (HDA) 3D Stereo Enhanced Sound System Sound-Blaster PRO™ Compatible	2 * Built-In Speakers Built-In Microphone
Keyboard & Pointing Device	Winkey Keyboard	Built-In TouchPad with Scrolling Function
Interface	Three USB 2.0 Ports One External Monitor Port One Headphone-Out Jack One Microphone-In Jack One Line-In Jack	One S/PDIF Out Jack One RJ-11 Modem Jack One RJ-45 LAN Jack One DC-in Jack
Card Reader	Embedded 7-in-1 Card Reader (MS/ MS Pro/ SD/ Mini SD/ MMC/ RS MMC/ MS Duo) Note: MS Duo/ Mini SD/ RS MMC Cards require a PC adapter	
ExpressCard Slot	One ExpressCard/34(54) Slot	
Communication	AZALIA 56K Plug & Play Fax/Modem V.90/92 Compliant 10M/100Mb Base-T Ethernet LAN 802.11 b/g USB Wireless LAN Module (Option) USB (2.0) Bluetooth Module - Version 2.0 (Factory Option) 300K or 1.3M Pixel USB PC Camera Module (Factory Option)	

Introduction

Feature	Specification	
Power Management	Supports ACPI 2.0 and PCI Bus Power Management 1.1 Compliant	Battery Low Suspend Supports Wake on LAN
Power	Full Range AC/DC Adapter 19V, 3.42A or 18.5V, 3.5A (65W), 100~240V, 50~60Hz	
Battery	6 Cell Smart Lithium-Ion Battery Pack, 4000mAh	
Environmental Spec	Temperature Operating: 5°C ~ 35°C Non-Operating: -20°C ~ 60°C	Relative Humidity Operating: 20% ~ 80% Non-Operating: 10% ~ 90%
Dimensions & Weight	360mm (w) * 267mm (d) * 25.4-34mm (h)	2.6 kg With 6 Cell Battery
Optional	Optical Drive Module Options: DVD/CD-RW Combo Drive Module DVD-Dual Drive Module	802.11 b/g USB Wireless LAN Module 300K or 1.3M Pixel USB PC Camera Module (Factory Option) USB (2.0) Bluetooth Module - Version 2.0 (Factory Option)

Model Differences

The models vary slightly in external cover design and color.



Figure 1
Model Differences

Introduction

Figure 2
Top View

External Locator - Top View with LCD Panel Open

1. Optional Built-In PC Camera
2. LCD
3. Speakers
4. Power Button
5. Hot Key Buttons
6. Keyboard
7. TouchPad and Buttons
8. Built-In Microphone
9. LED Indicators

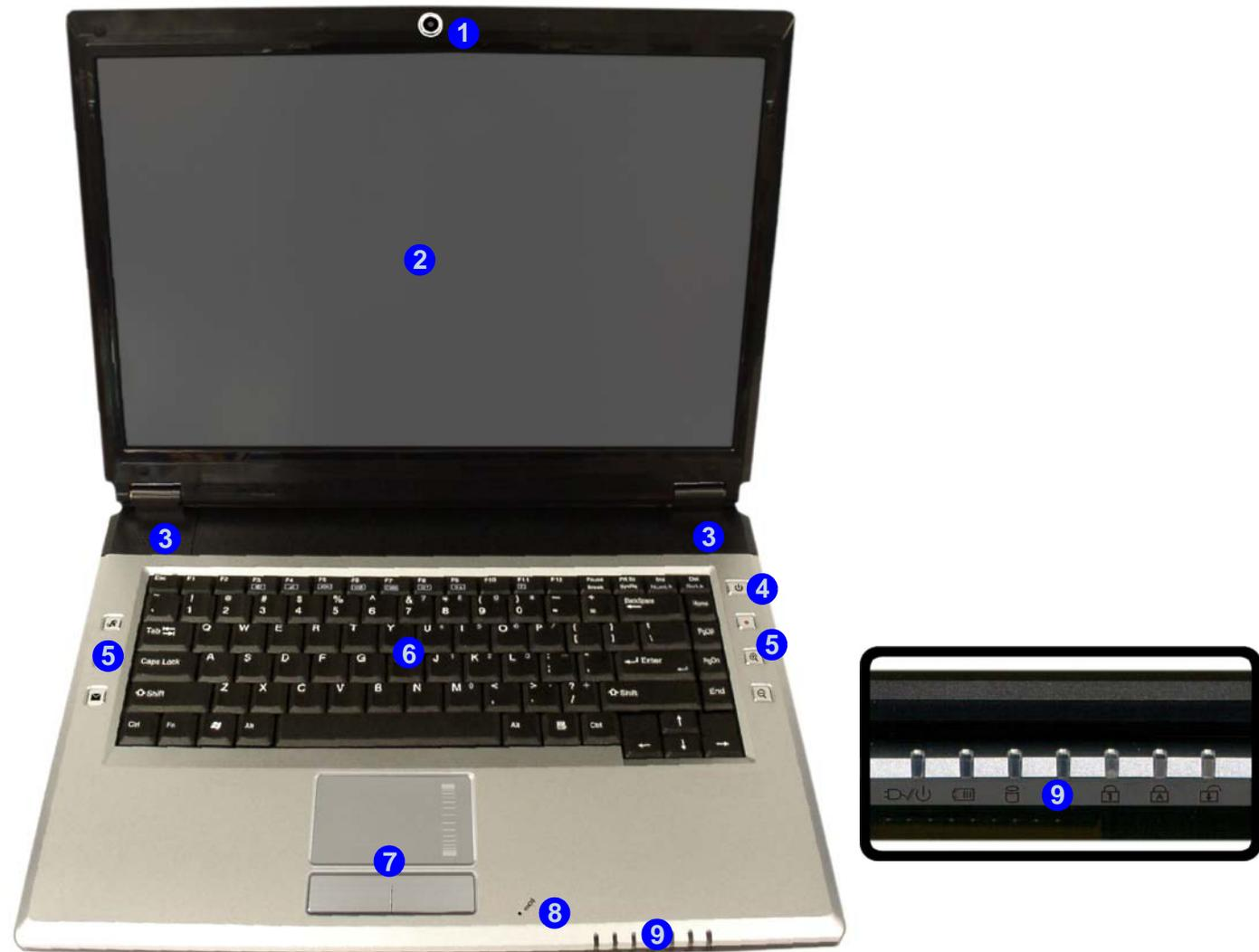

1 - 6 External Locator - Top View with LCD Panel Open

External Locator - Front & Rear Views



Figure 3
Front Views
1. LED Indicators



Figure 4
Rear Views
1. 1 * USB Port
2. DC-In Jack
3. Battery

Introduction

External Locator - Left & Right Side Views

Figure 5
Left Side View

1. Security Lock Slot
2. Optical Device Drive Bay
3. RJ-11 Modem Jack
4. S/PDIF-Out Jack
5. Microphone-In Jack
6. Headphone-Out Jack
7. Line-In Jack



Figure 6
Right Side View

1. ExpressCard Slot
2. 7-in-1 Card Reader
3. 2 * USB 2.0 Ports
4. RJ-45 LAN Jack
5. External Monitor Port

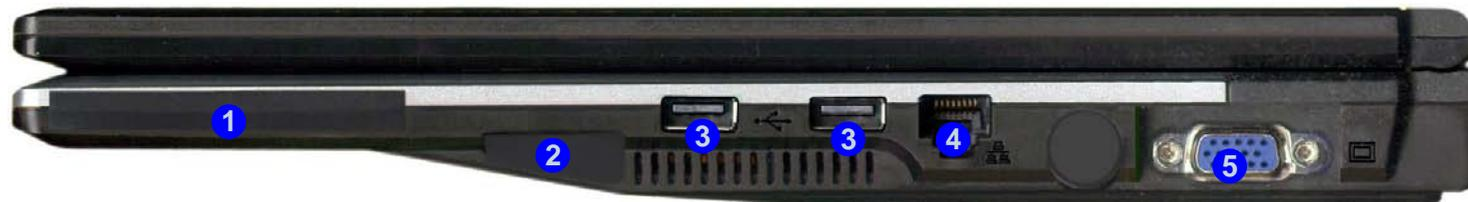

1 - 8 External Locator - Left & Right Side Views

External Locator - Bottom View

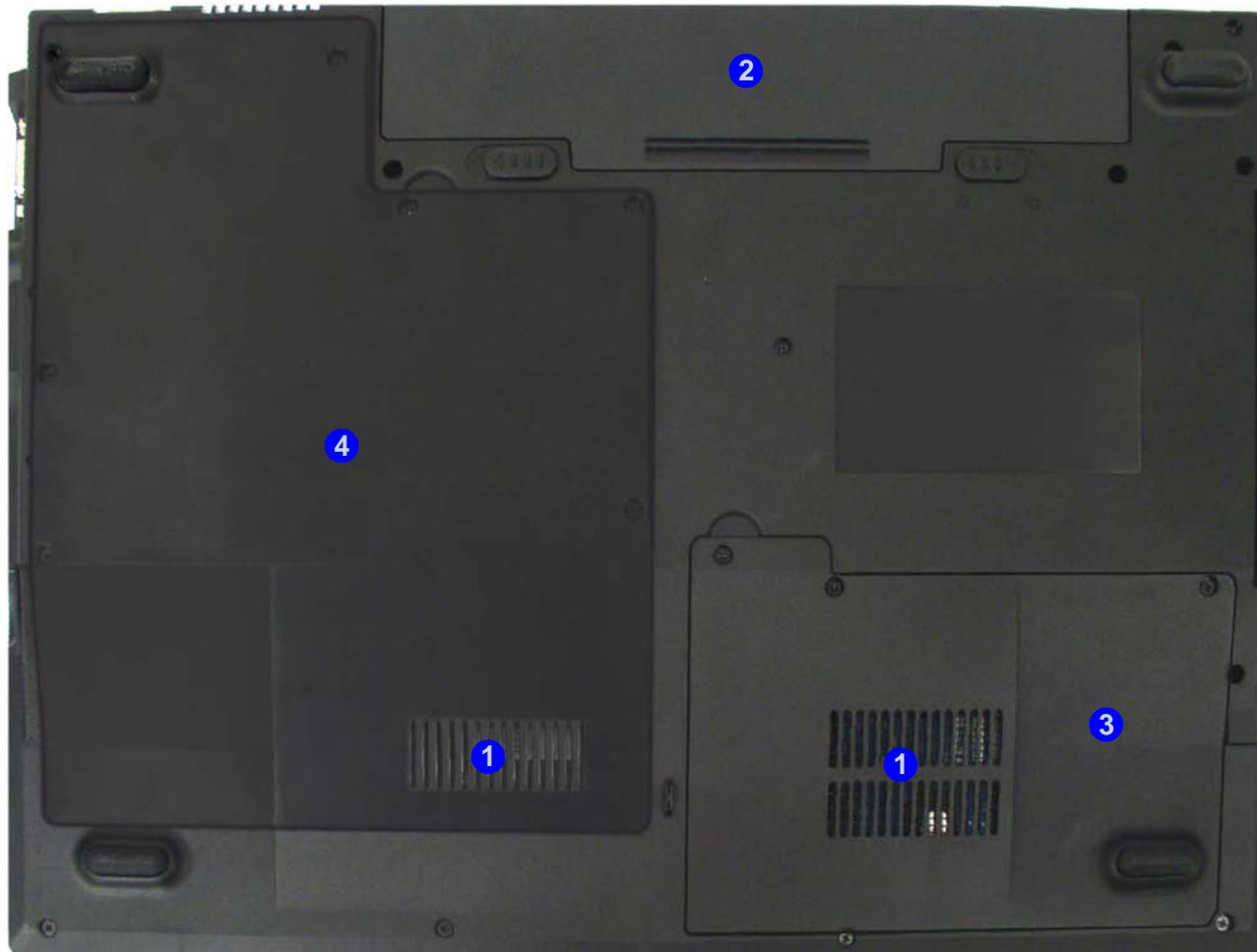

Figure 7
Bottom View

1. Vent/Fan Intake
2. Battery
3. Hard Disk Bay Cover
4. CPU/RAM Bay Cover



Overheating

To prevent your computer from overheating make sure nothing blocks the vent/fan intakes while the computer is in use.

Introduction

Figure 8
Mainboard Top
Key Parts

1. Audio Codec
VT1613
2. Audio Amp
3. Hitachi H8
4. Card Reader
Control
5. PC Card
Assembly

M660SE Mainboard Overview - Top (Key Parts)

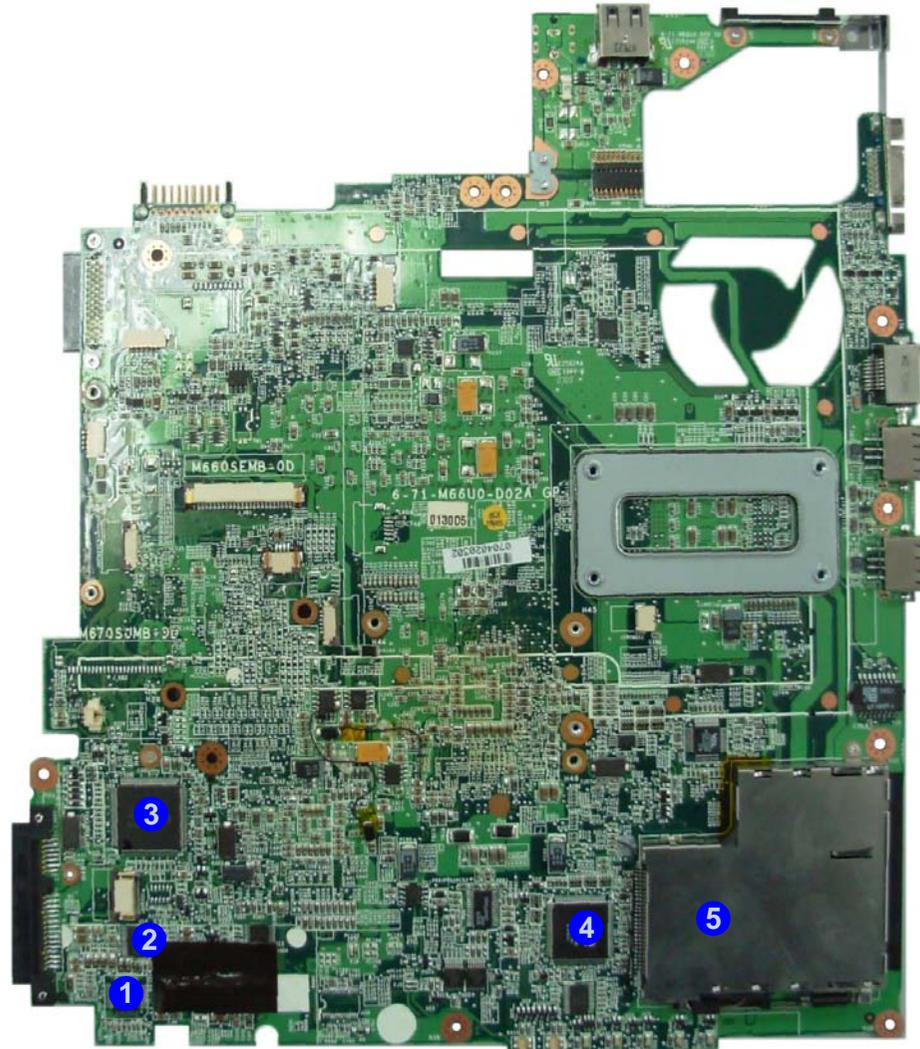

1 - 10 M660SE Mainboard Overview - Top (Key Parts)

M660SE Mainboard Overview - Bottom (Key Parts)



Figure 9
**Mainboard Bottom
Key Parts**

1. CPU Socket (no CPU installed)
2. Memory Slots DDR2 So-DIMM
3. Northbridge-VN896
4. ICS Clock Generator
5. Southbridge-VT8237A
6. Flash BIOS ROM

Introduction

Figure 10
**Mainboard Top
Connectors**

1. External Monitor Port
2. RJ-45 LAN Jack
3. USB Port
4. HDD Connector
5. Hotkey Cable Connector
6. Power Hotkey Cable Connector
7. Touch Pad Cable Connector
8. Keyboard Cable Connector
9. Speaker Cable Connector
10. Inverter Cable Connector
11. CCD Cable Connector

M660SE Mainboard Overview - Top (Connectors)

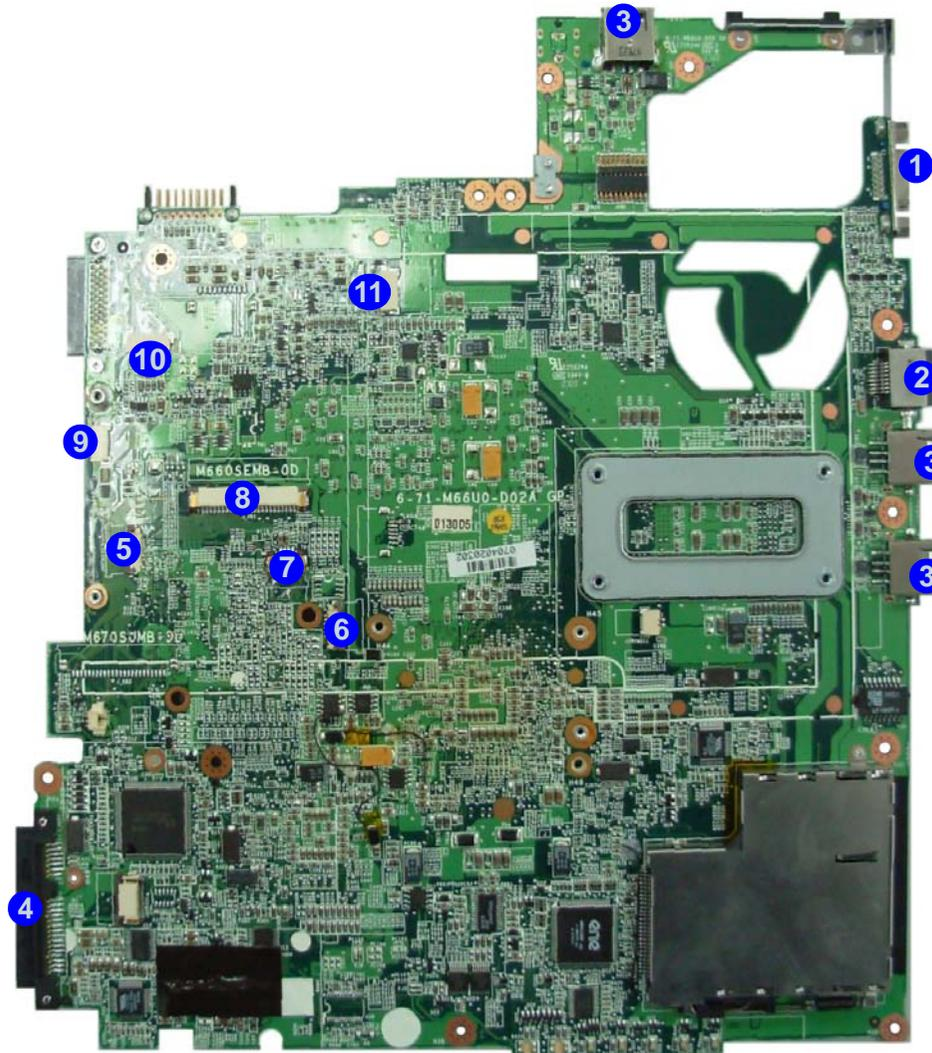

1 - 12 M660SE Mainboard Overview - Top (Connectors)

M660SE Mainboard Overview - Bottom (Connectors)



Figure 11
**Mainboard Bottom
Connectors**

1. DC-In Jack
2. Fan Cable Connector
3. LCD Cable Connector
4. Battery Connector
5. Optical Device Drive Connector
6. Bluetooth Cable Connector
7. Card Reader

Chapter 2: Disassembly

Overview

This chapter provides step-by-step instructions for disassembling the *M660SE/M665SE* series notebook's parts and sub-systems. When it comes to reassembly, reverse the procedures (unless otherwise indicated).

We suggest you completely review any procedure before you take the computer apart.

Procedures such as upgrading/replacing the RAM, CD device and hard disk are included in the User's Manual but are repeated here for your convenience.

To make the disassembly process easier each section may have a box in the page margin. Information contained under the figure # will give a synopsis of the sequence of procedures involved in the disassembly procedure. A box with a  lists the relevant parts you will have after the disassembly process is complete. **Note:** The parts listed will be for the disassembly procedure listed ONLY, and not any previous disassembly step(s) required. Refer to the part list for the previous disassembly procedure. The amount of screws you should be left with will be listed here also.

A box with a  will also provide any possible helpful information. A box with a  contains warnings.

An example of these types of boxes are shown in the sidebar.

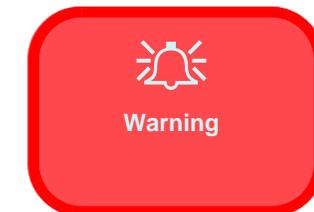

Disassembly

NOTE: All disassembly procedures assume that the system is turned **OFF**, and disconnected from any power supply (the battery is removed too).

Maintenance Tools

The following tools are recommended when working on the notebook PC:

- M3 Philips-head screwdriver
- M2.5 Philips-head screwdriver (magnetized)
- M2 Philips-head screwdriver
- Small flat-head screwdriver
- Pair of needle-nose pliers
- Anti-static wrist-strap

Connections

Connections within the computer are one of four types:

Locking collar sockets for ribbon connectors	To release these connectors, use a small flat-head screwdriver to gently pry the locking collar away from its base. When replacing the connection, make sure the connector is oriented in the same way. The pin1 side is usually not indicated.
Pressure sockets for multi-wire connectors	To release this connector type, grasp it at its head and gently rock it from side to side as you pull it out. Do not pull on the wires themselves. When replacing the connection, do not try to force it. The socket only fits one way.
Pressure sockets for ribbon connectors	To release these connectors, use a small pair of needle-nose pliers to gently lift the connector away from its socket. When replacing the connection, make sure the connector is oriented in the same way. The pin1 side is usually not indicated.
Board-to-board or multi-pin sockets	To separate the boards, gently rock them from side to side as you pull them apart. If the connection is very tight, use a small flat-head screwdriver - use just enough force to start.

Maintenance Precautions

The following precautions are a reminder. To avoid personal injury or damage to the computer while performing a removal and/or replacement job, take the following precautions:

1. **Don't drop it.** Perform your repairs and/or upgrades on a stable surface. If the computer falls, the case and other components could be damaged.
2. **Don't overheat it.** Note the proximity of any heating elements. Keep the computer out of direct sunlight.
3. **Avoid interference.** Note the proximity of any high capacity transformers, electric motors, and other strong magnetic fields. These can hinder proper performance and damage components and/or data. You should also monitor the position of magnetized tools (i.e. screwdrivers).
4. **Keep it dry.** This is an electrical appliance. If water or any other liquid gets into it, the computer could be badly damaged.
5. **Be careful with power.** Avoid accidental shocks, discharges or explosions.
 - Before removing or servicing any part from the computer, turn the computer off and detach any power supplies.
 - When you want to unplug the power cord or any cable/wire, be sure to disconnect it by the plug head. Do not pull on the wire.
6. **Peripherals** – Turn off and detach any peripherals.
7. **Beware of static discharge.** ICs, such as the CPU and main support chips, are vulnerable to static electricity. Before handling any part in the computer, discharge any static electricity inside the computer. When handling a printed circuit board, do not use gloves or other materials which allow static electricity buildup. We suggest that you use an anti-static wrist strap instead.
8. **Beware of corrosion.** As you perform your job, avoid touching any connector leads. Even the cleanest hands produce oils which can attract corrosive elements.
9. **Keep your work environment clean.** Tobacco smoke, dust or other air-borne particulate matter is often attracted to charged surfaces, reducing performance.
10. **Keep track of the components.** When removing or replacing any part, be careful not to leave small parts, such as screws, loose inside the computer.

Cleaning

Do not apply cleaner directly to the computer, use a soft clean cloth.

Do not use volatile (petroleum distillates) or abrasive cleaners on any part of the computer.



Power Safety Warning

Before you undertake any upgrade procedures, make sure that you have turned off the power, and disconnected all peripherals and cables (including telephone lines). It is advisable to also remove your battery in order to prevent accidentally turning the machine on.

Disassembly Steps

The following table lists the disassembly steps, and on which page to find the related information. **PLEASE PERFORM THE DISASSEMBLY STEPS IN THE ORDER INDICATED.**

To remove the Battery:

1. Remove the battery [page 2 - 5](#)

To remove the HDD:

1. Remove the battery [page 2 - 5](#)
2. Remove the HDD [page 2 - 6](#)

To remove the System Memory:

1. Remove the battery [page 2 - 5](#)
2. Remove the system memory [page 2 - 8](#)

To remove the Processor:

1. Remove the battery [page 2 - 5](#)
2. Remove the processor [page 2 - 10](#)

To remove the Wireless LAN Module:

1. Remove the battery [page 2 - 5](#)
2. Remove the wireless LAN [page 2 - 12](#)

To remove the Modem :

1. Remove the battery [page 2 - 5](#)
2. Remove the modem [page 2 - 13](#)

To remove the Bluetooth:

1. Remove the battery [page 2 - 5](#)
2. Remove the bluetooth [page 2 - 14](#)

To remove the Optical Device:

1. Remove the battery [page 2 - 5](#)
2. Remove the Optical device [page 2 - 15](#)

To remove the Keyboard:

1. Remove the battery [page 2 - 5](#)
2. Remove the keyboard [page 2 - 16](#)

Removing the Battery

1. Turn the computer **off**, and turn it over.
2. Slide the latches (1 & 2) the direction of the arrow, and hold latch 2 in place.
3. Slide the battery in the direction of the arrow 3.
4. Lift the battery 4 out.

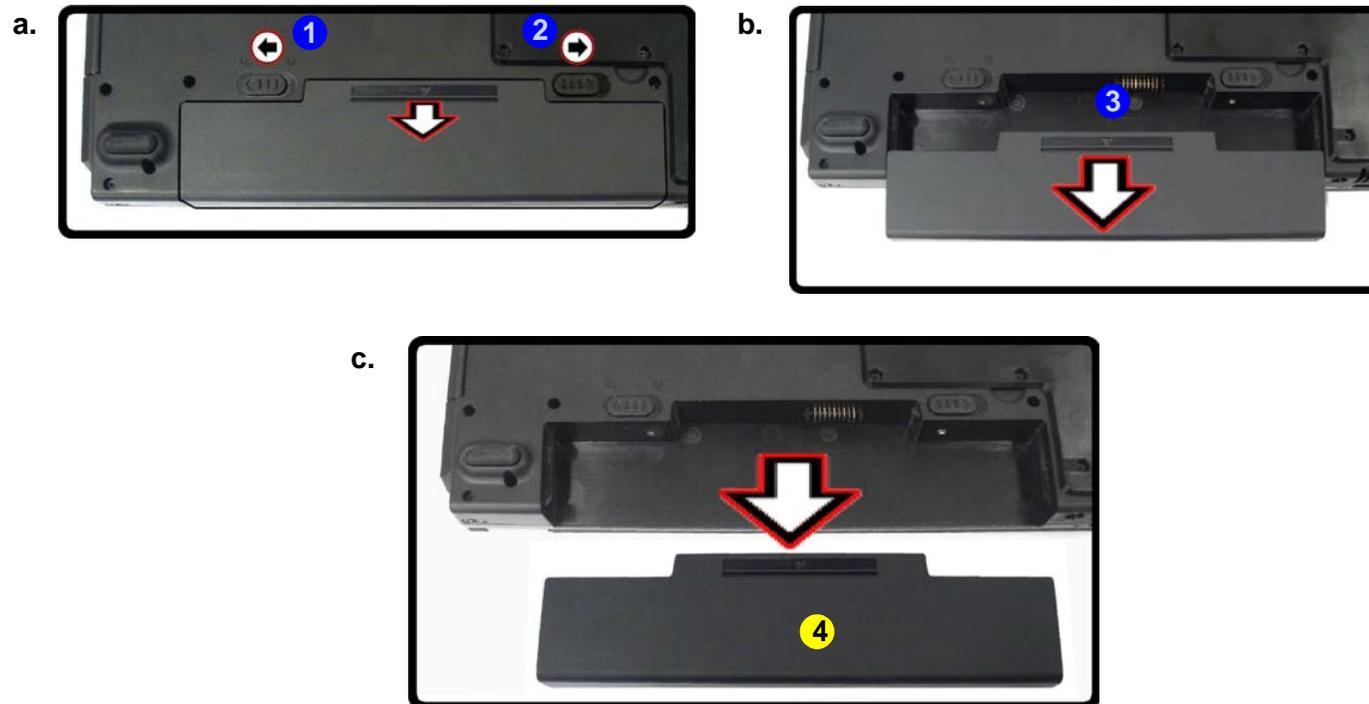
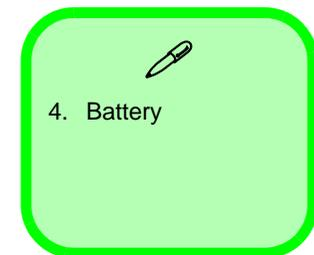

Figure 1
Battery Removal

- a. Slide the 2 latches and hold latch 2 in place.
- b. Slide the battery in the direction of the arrow.
- c. Lift the battery out.



Disassembly

Figure 2
**HDD Assembly
Removal**

- Locate the HDD bay cover and remove the screws.
- Remove the bay cover.

Removing the Hard Disk Drive

The hard disk drive can be taken out to accommodate other 2.5" serial (SATA) hard disk drives with a height of 9.5mm (h). Follow your operating system's installation instructions, and install all necessary drivers and utilities (as outlined in **Chapter 4 of the User's Manual**) when setting up a new hard disk.

Hard Disk Upgrade Process:

- Turn **off** the computer, and remove the battery ([page 2 - 5](#)).
- Locate the hard disk bay cover and remove the screws (1 - 3).
- Remove the bay cover (4).

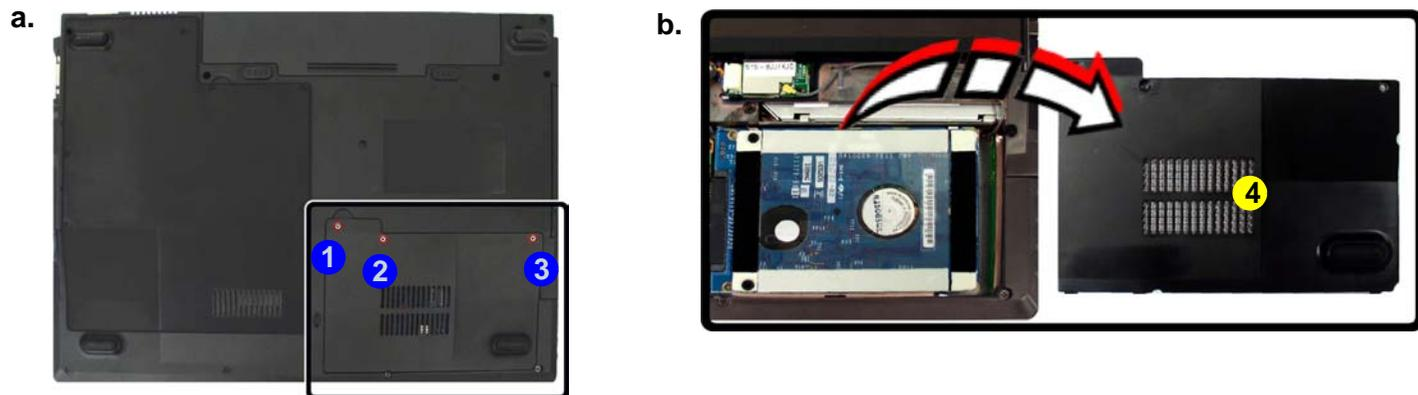

4. HDD Bay Cover
- 3 Screw



HDD System Warning

New HDD's are blank. Before you begin make sure:

You have backed up any data you want to keep from your old HDD.

You have all the CD-ROMs and FDDs required to install your operating system and programs.

If you have access to the internet, download the latest application and hardware driver updates for the operating system you plan to install. Copy these to a removable medium.

- Carefully grip the mylar tab **5** and slide the hard disk in the direction of arrow.
- Lift the hard disk up (**Figure d**) in the direction of arrow.
- Remove the screws **6** - **7** and separate the mylar cover **8** from the hard disk **9**.
- Reverse the process to install any new hard disk.

c.

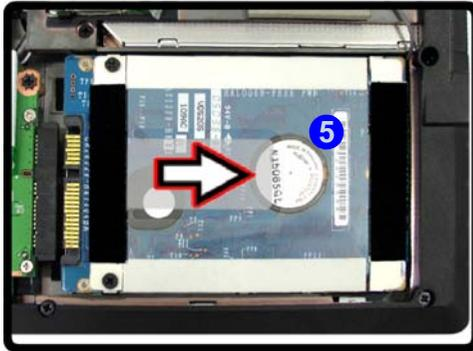

d.

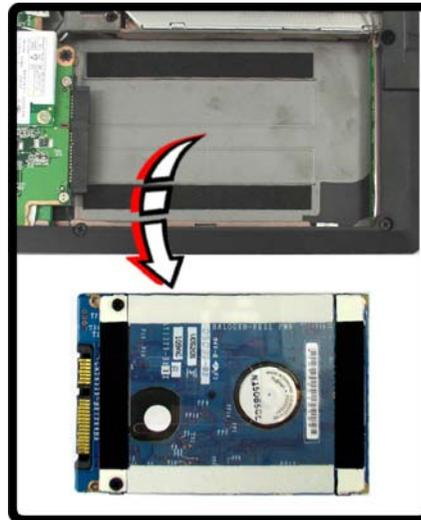

e.

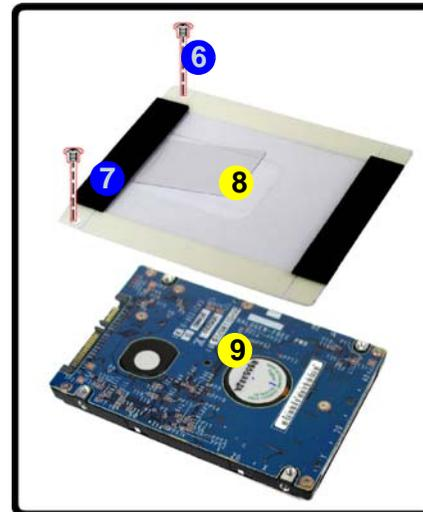

- Figure 3*
**HDD Assembly
Removal Sequence**
- Slide the HDD in the direction of the arrow.
 - Lift the HDD out of the bay.
 - Remove the screws and separate the mylar cover from the HDD.



- Mylar Cover
- HDD

Disassembly

Figure 4
RAM Module Removal

- Remove the screws.
- Remove the cover.

Removing the System Memory (RAM)

The computer has two memory sockets for 200 pin Small Outline Dual In-line Memory Modules (SO-DIMM) supporting **DDRII** 533/667MHz. The main memory can be expanded up to 2GB. The SO-DIMM modules supported are 256MB, 512MB and 1024MB **DDRII** Modules. The total memory size is automatically detected by the POST routine once you turn on your computer.

Memory Upgrade Process

- Turn **off** the computer, remove the battery ([page 2 - 5](#)).
- Locate the CPU/RAM bay cover, and remove screws **1** - **7**.
- Remove the bay cover **8**.
- The RAM will be visible at point **9** on the mainboard.

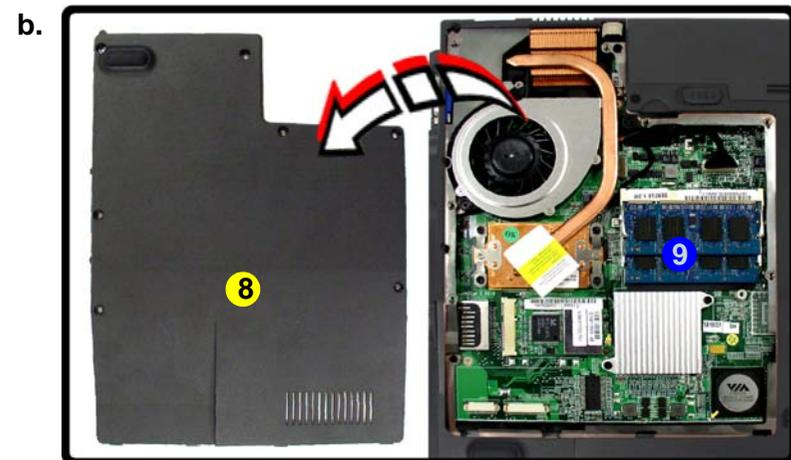
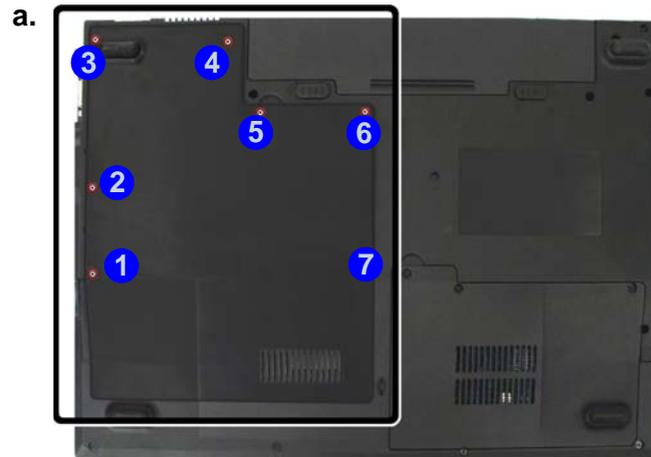

Contact Warning

Be careful not to touch the metal pins on the module's connecting edge. Even the cleanest hands have oils which can attract particles, and degrade the module's performance.



8. CPU/RAM Bay Cover

- 7 Screws

Figure 5
Memory Removal Sequence

- c. Push the release latch(es).
- d. Remove the module(s).

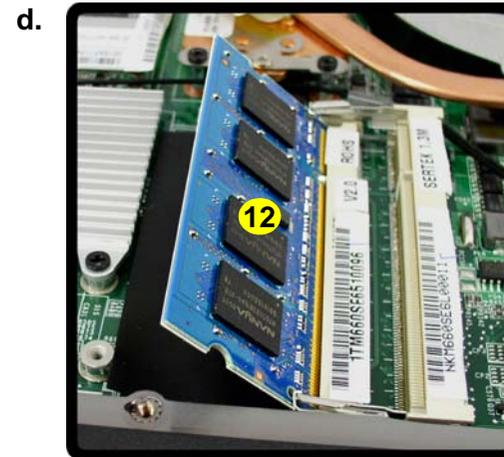
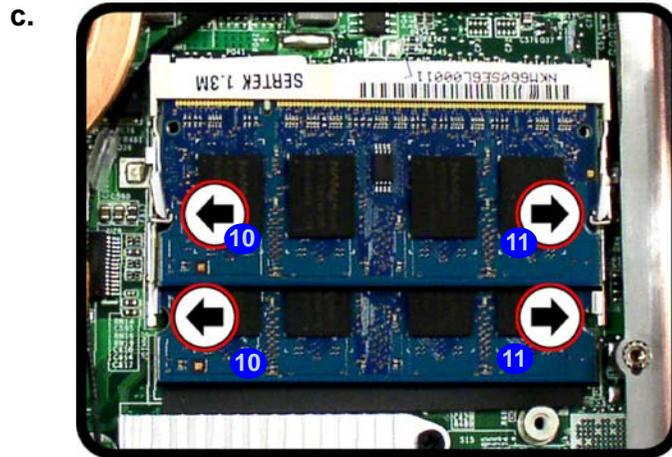

- 7. Push the latches to release the second module if necessary.
- 8. Insert a new module holding it at about a 30° angle and fit the connectors firmly into the memory slot.
- 9. The module will only fit one way as defined by its pin alignment. Make sure the module is seated as far into the slot as it will go. **DO NOT FORCE IT**; it should fit without much pressure.
- 10. Press the module down towards the mainboard until the slot levers click into place to secure the module.
- 11. Replace the bay cover and the screws (see [page 2 - 8](#)).
- 12. Restart the computer to allow the BIOS to register the new memory configuration as it starts up.



12 RAM Module(s)

Disassembly

Figure 6

Processor Removal

- Remove the cover and locate the heat sink.
- Remove the 4 screws in the order indicated.
- Remove the heat sink.

Removing the Processor

- Turn off the computer, and remove the battery ([page 2 - 5](#)) and the CPU/RAM bay cover ([page 2 - 8](#)).
- The CPU heat sink will be visible at point **1** on the mainboard.
- Remove screws **2** - **5** from the heat sink in the order indicated.
- Carefully lift up the heat sink **6** ([Figure c](#)) off the computer.

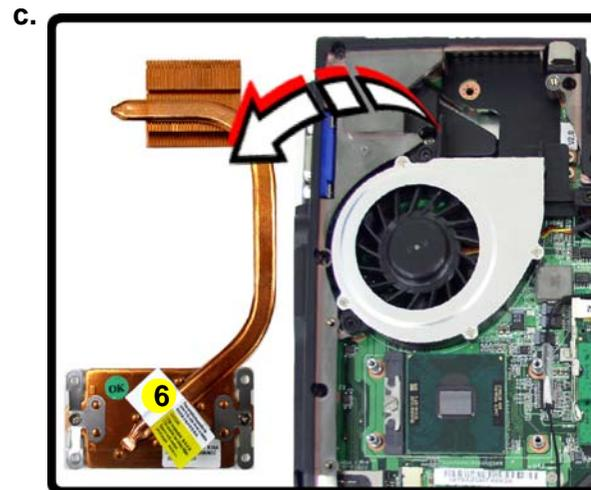
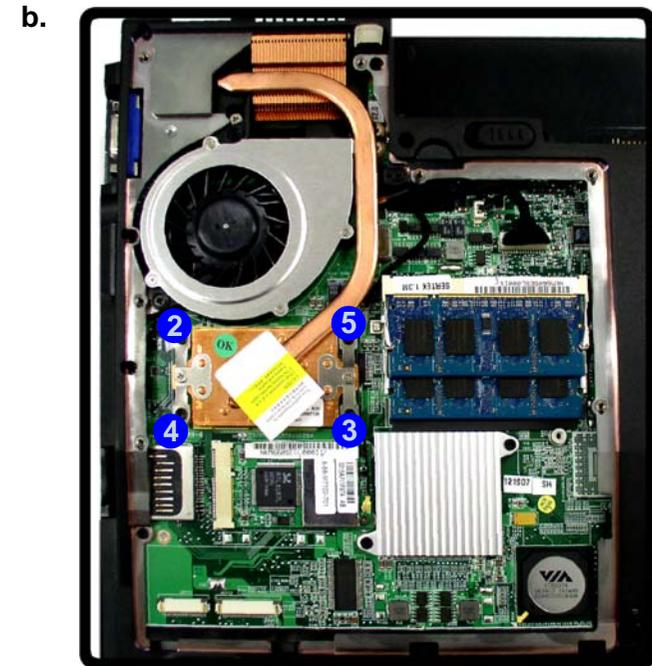
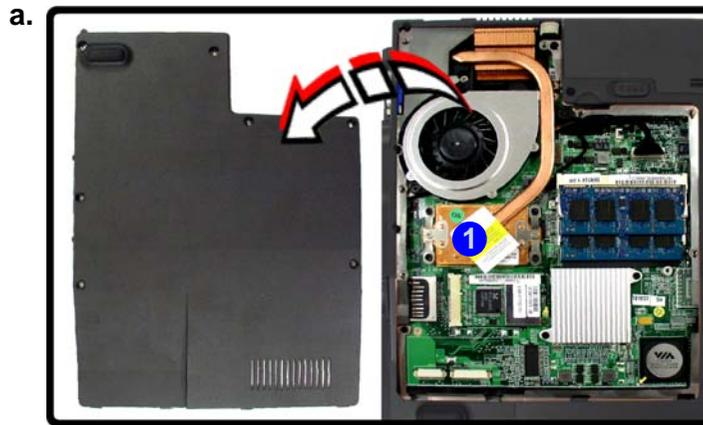

6. Heat Sink

- 4 Screws

- Turn the release latch **7** towards the unlock symbol , to release the CPU (*Figure d*).
- Carefully (it may be hot) lift the CPU **8** up out of the socket (*Figure e*).
- Reverse the process to install a new CPU.
- When re-inserting the CPU, pay careful attention to the pin alignment, it will fit only one way (DO NOT FORCE IT!).

Figure 7
Processor Removal (cont'd)

- Turn the release latch to unlock the CPU.
- Lift the CPU out of the socket.

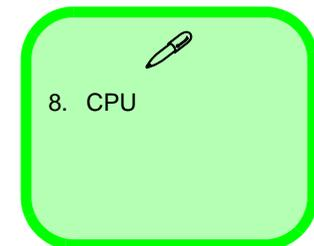
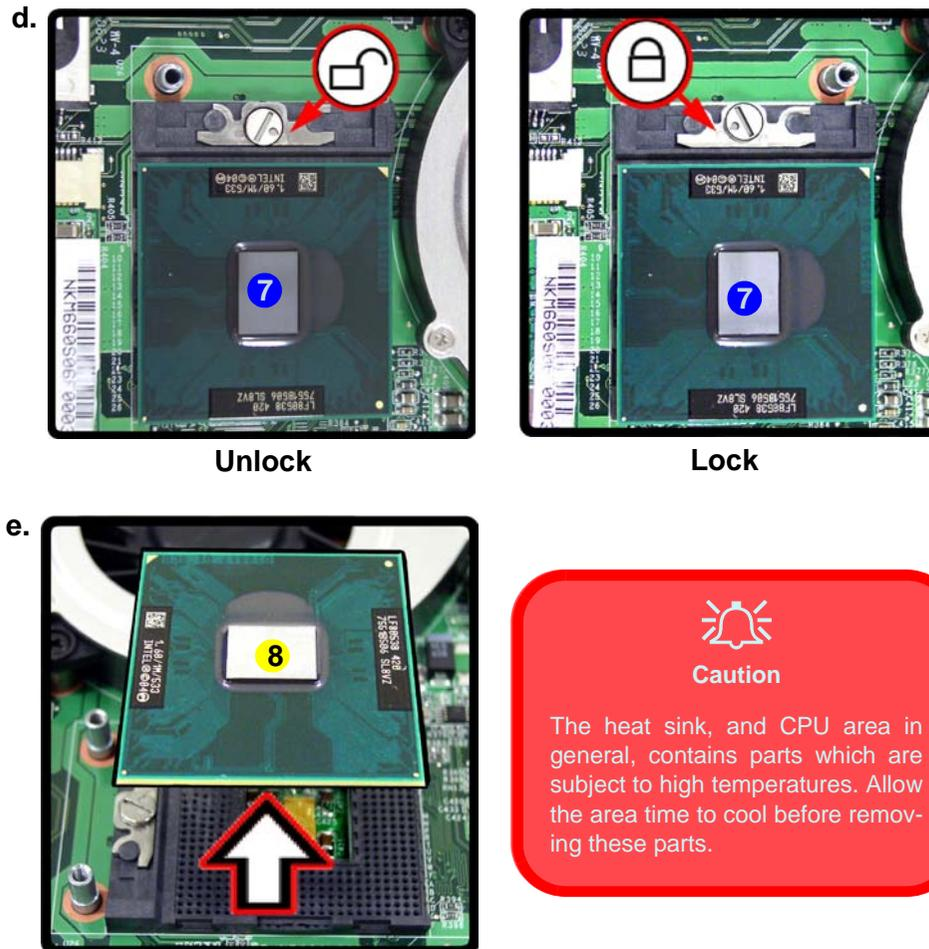

Disassembly

Figure 8
**Wireless LAN
Module Removal**

- Remove the cover and locate the heat sink.
- Disconnect the cable and remove the 2 screws.
- The WLAN module will pop up.
- Remove the WLAN module.

Note: Make sure you reconnect the antenna cable to the “Main” socket (*Figure b*).

Removing the Wireless LAN Module

- Turn off the computer, remove the battery ([page 2 - 5](#)) and the module bay cover ([page 2 - 8](#)).
- The Wireless LAN module will be visible at point **1** on the mainboard.
- Carefully disconnect cable **2**, then remove the screws **3** - **4** from the module socket.
- The wireless LAN module **5** will pop-up.
- Lift the wireless LAN module (*Figure d*) up and off the computer.

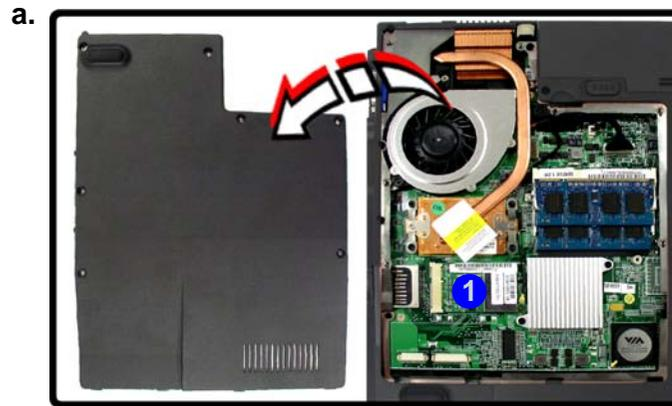

5. WLAN Module

- 2 Screws

Removing the Modem

1. Turn **off** the computer, remove the battery ([page 2 - 5](#)), and remove the hard disk bay cover ([page 2 - 6](#)).
2. The modem will be visible at point **1** on the mainboard.
3. Remove screws **2** - **3** from the modem module.
4. Lift the modem up off the socket **4** and separate the modem from the connector **5**.
5. Lift the modem **6** up and off the computer.

Figure 9
Modem Removal

- a. Remove the cover and locate the modem.
- b. Remove the screws.
- c. Lift the modem up off the socket and disconnect the connector.
- d. Lift the modem out.

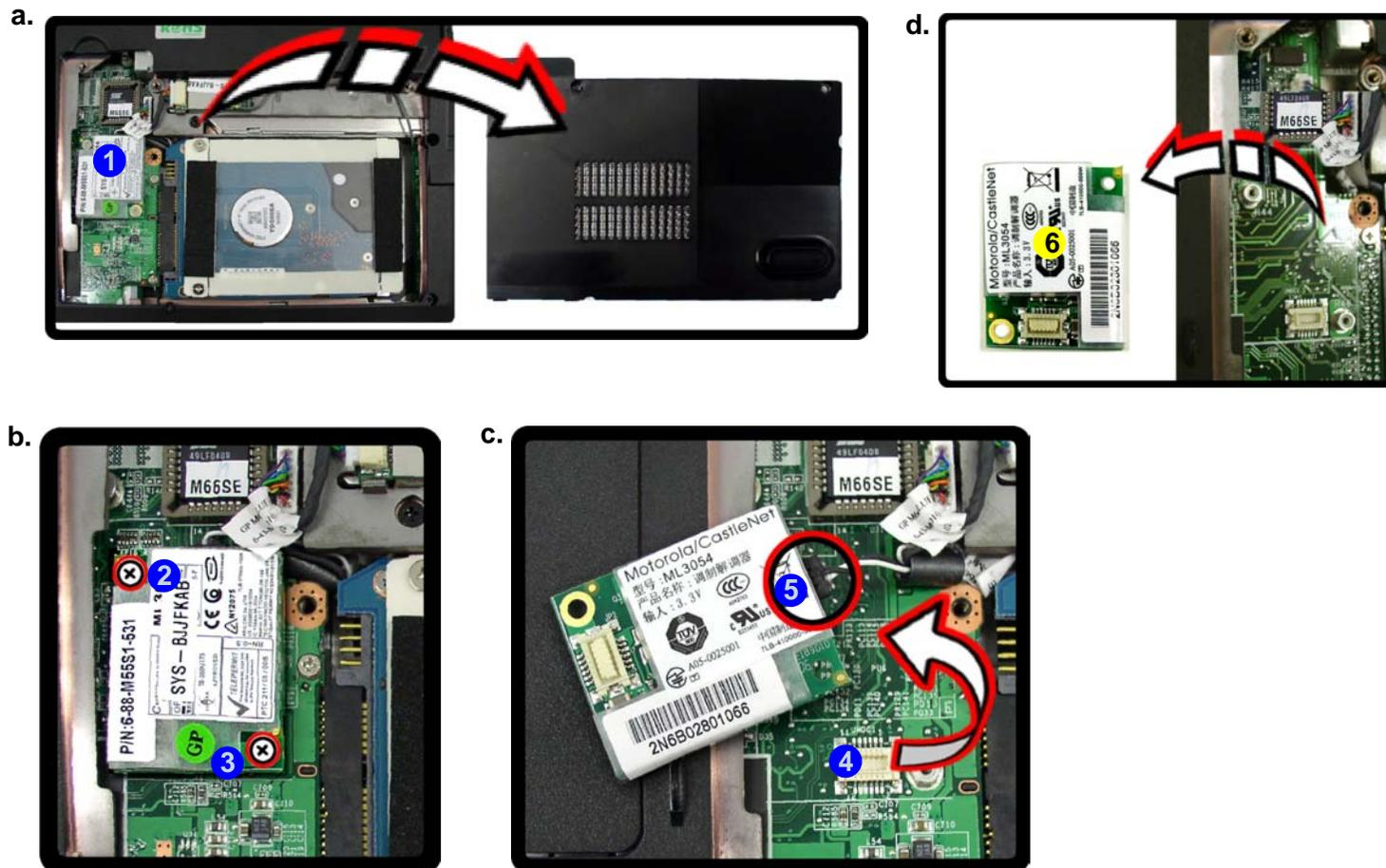

✍️

6. Modem

- 2 Screws

Disassembly

Figure 10
Bluetooth Removal

- Remove the cover and locate the Bluetooth module.
- Separate the the module from connector and disconnect the cable.
- Remove Bluetooth module.

Removing the Bluetooth Module

- Turn off the computer, remove the battery ([page 2 - 5](#)) and remove the hard disk bay cover ([page 2 - 6](#)).
- The Bluetooth module will be visible at point **1** on the mainboard.
- Carefully separate the module from the connector **2** and disconnect the cable **3**.
- Lift the Bluetooth module **4** ([Figure c](#)) up and off the computer.



4. Bluetooth Module

Removing the Optical (CD/DVD) Device

1. Turn off the computer, remove the battery ([page 2 - 5](#)).
2. Locate the hard disk bay cover and remove screws (1 - 3).
3. Remove the bay cover (4).
4. Remove the screw at point (5), and use a screwdriver to carefully push out the optical device at point (6).
5. Insert the new device and carefully slide it into the computer (the device only fits one way. DO NOT FORCE IT; The screw holes should line up).
6. Restart the computer to allow it to automatically detect the new device.

Figure 11
Optical Device Removal

- a. Remove the screws.
- b. Remove the cover.
- c. Remove the screw and push the optical device out off the computer at point 6.
- d. Remove the optical device.

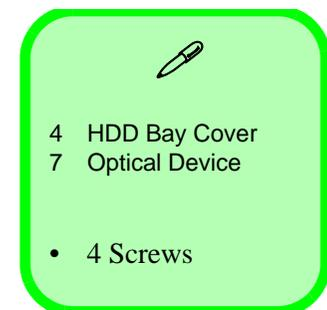
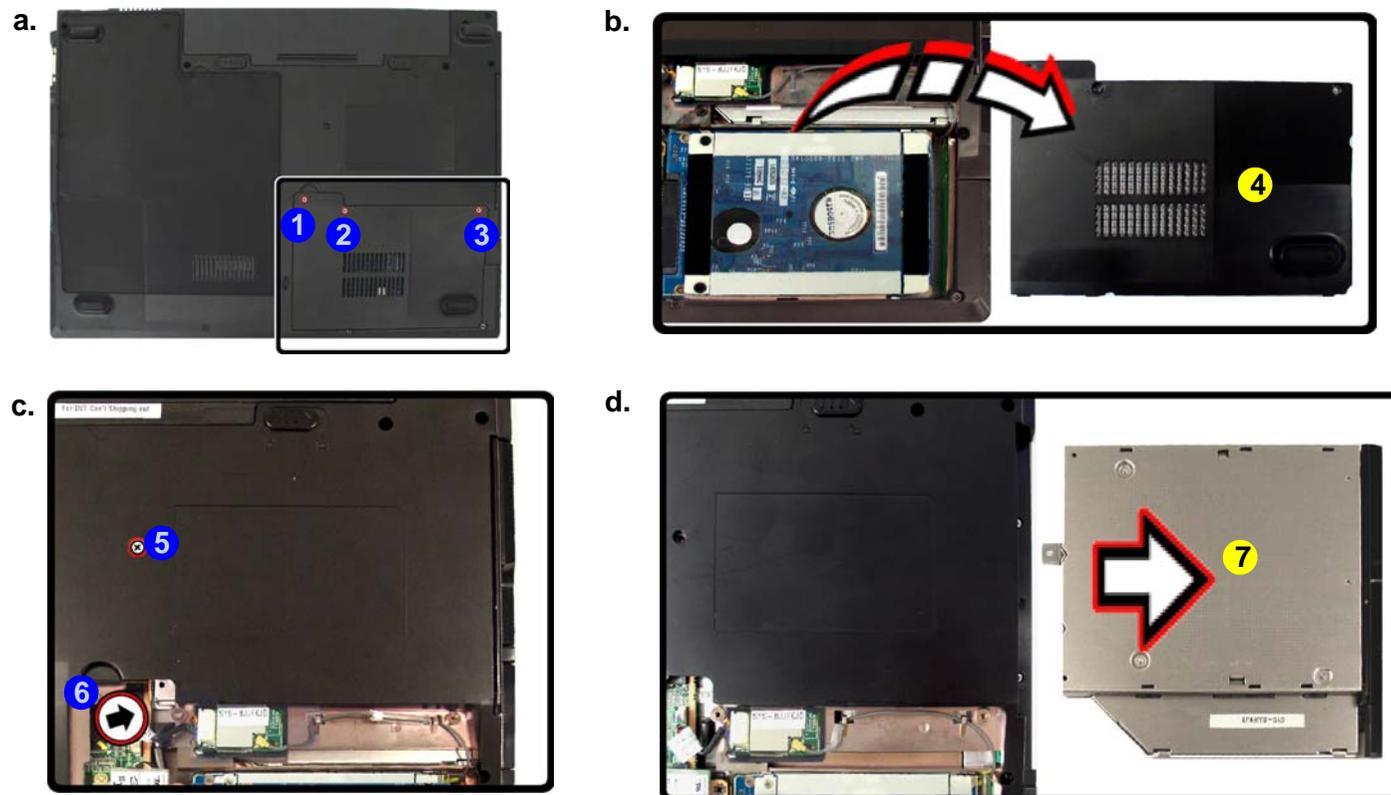

Disassembly

Figure 12
Keyboard Removal

- a. Press the three latches to release the keyboard.
- b. Lift the keyboard up and disconnect the cable from the locking collar.
- c. Remove the keyboard.

Removing the Keyboard

1. Turn **off** the computer, and remove the battery ([page 2 - 5](#)).
2. Press the **three** keyboard latches at the top of the keyboard to elevate the keyboard from its normal position (you may need to use a small screwdriver to do this).
3. Carefully lift the keyboard up, being careful not to bend the keyboard ribbon cable ([Figure b](#)).
4. Disconnect the keyboard ribbon cable **4** from the locking collar socket **5**.
5. Carefully lift up the keyboard **6** ([Figure c](#)) off the computer.

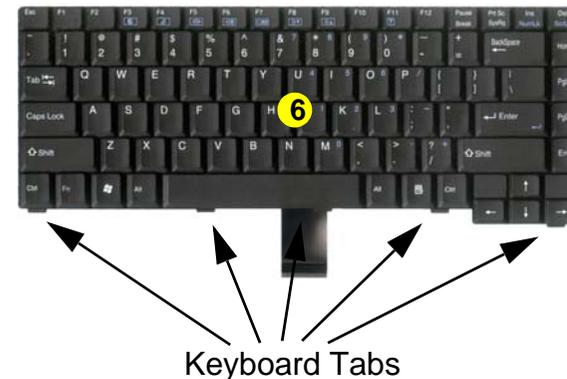
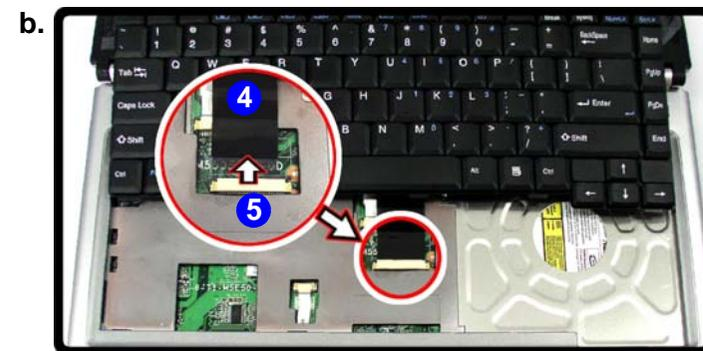

Re-Inserting the Keyboard

When re-inserting the keyboard firstly align the **five** keyboard tabs at the bottom of the keyboard with the slots in the case.



6. Keyboard

Appendix A:Part Lists

This appendix breaks down the *M660SE/M665SE* series notebook's construction into a series of illustrations. The component part numbers are indicated in the tables opposite the drawings.

Note: This section indicates the *manufacturer's* part numbers. Your organization may use a different system, so be sure to cross-check any relevant documentation.

Note: Some assemblies may have parts in common (especially screws). However, the part lists DO NOT indicate the total number of duplicated parts used.

Note: Be sure to check any update notices. The parts shown in these illustrations are appropriate for the system at the time of publication. Over the product life, some parts may be improved or re-configured, resulting in *new* part numbers.

Part List Illustration Location

The following table indicates where to find the appropriate part list illustration.

Table A - 1
Part List Illustration
Location

Part	Pages#
Top - (M660SE)	<i>page A - 3</i>
Top - (M665SE)	<i>page A - 4</i>
Bottom - (M660SE/M665SE)	<i>page A - 5</i>
LCD - (M660SE/M665SE)	<i>page A - 6</i>
CDRW - (M660SE/M665SE)	<i>page A - 7</i>
Combo - (M660SE/M665SE)	<i>page A - 8</i>
DVDRW - (M660SE/M665SE)	<i>page A - 9</i>

Top (M660SE)

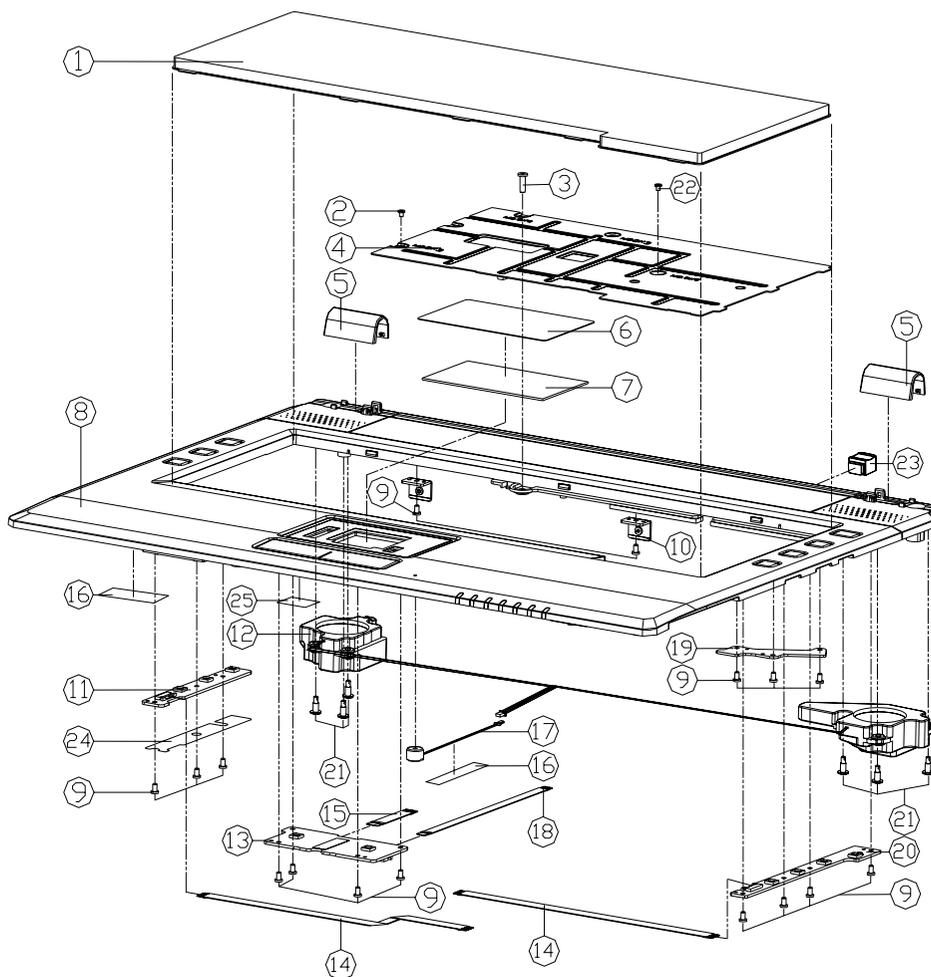

Figure A - 1
Top (M660SE)

ITEM	PART NAME	PART NO	REMARK
1	KEYBOARD(OPTION)	6-80-M55G0-011-1	
2	SCREW M2*3L KI NI ICT QTY-PATCH	6-35-B1120-3RE	
3	SCREW M2.5*BL KI BK/Z NY ICT	6-35-B6125-BR0	
4	KEYBOARD SHIELDING M660JE	6-33-M66E7-010	
5	HINGE COVER FOR M660N	6-42-M66N2-011	
6	TOUCH PAD MYLAR (C) 2.25*3.00*0.15	6-40-M55G2-025	
7	TOUCH PAD TMS1P22R389 M660JE	6-49-M66E2-010	
8	TOP CASE MODULE	6-39-M66N2-015	
9	SCREW M2*3L KI NI ICT NY	6-35-B1120-3RA	
10	REAR REINFORCE BRACKET	6-33-M66N2-031	
11	HOTKEY LT BOARD	6-77-M66NS-011	
12	SPEAKER-L/R 25*10*8 15W 4OH 185M/24N	6-23-5M66N-012	
13	CLICK BOARD	6-77-M66U2-D01-1	
14	FFC CABLE FOR PWR-HOTKEY 6P PITCH=1.0MM	6-43-M66N0-010	
15	FFC CABLE FOR TOUCHPAD BOARD 12P PITCH=0.5	6-43-M66N0-030	
16	TAPE MYLAR (C) MYLAR M550J	6-40-M55J2-030	
17	MICROPHONE 6MM35*6MM35-FIL-W 10V2V 22K	6-23-EM55G-010	
18	FFC CABLE FOR CLICK BOARD 4P PITCH=1.0MM	6-43-M66N0-020	
19	CABLE ALIGN BRACKET	6-33-M66N2-040	
20	POWER HOT BOARD	6-77-M66NS-D01	
21	SCREW FOR SPEAKER M2	6-35-20Z20-000	
22	SCREW M2.5*5L KI BK/Z ICT NY	6-35-B6125-SRA	
23	MINI-1394 RUBBER	6-47-M66SP-010	
24	MYLAR 4P 83.74*41.175MM 0P 7507 M66N	6-40-M66NS-090	
25	TOUCH PAD GROND AL TOLL2240 FOR OLA M55G	6-47-M55G2-020	

A.Part Lists

Top (M665SE)

Figure A - 2
Top (M665SE)

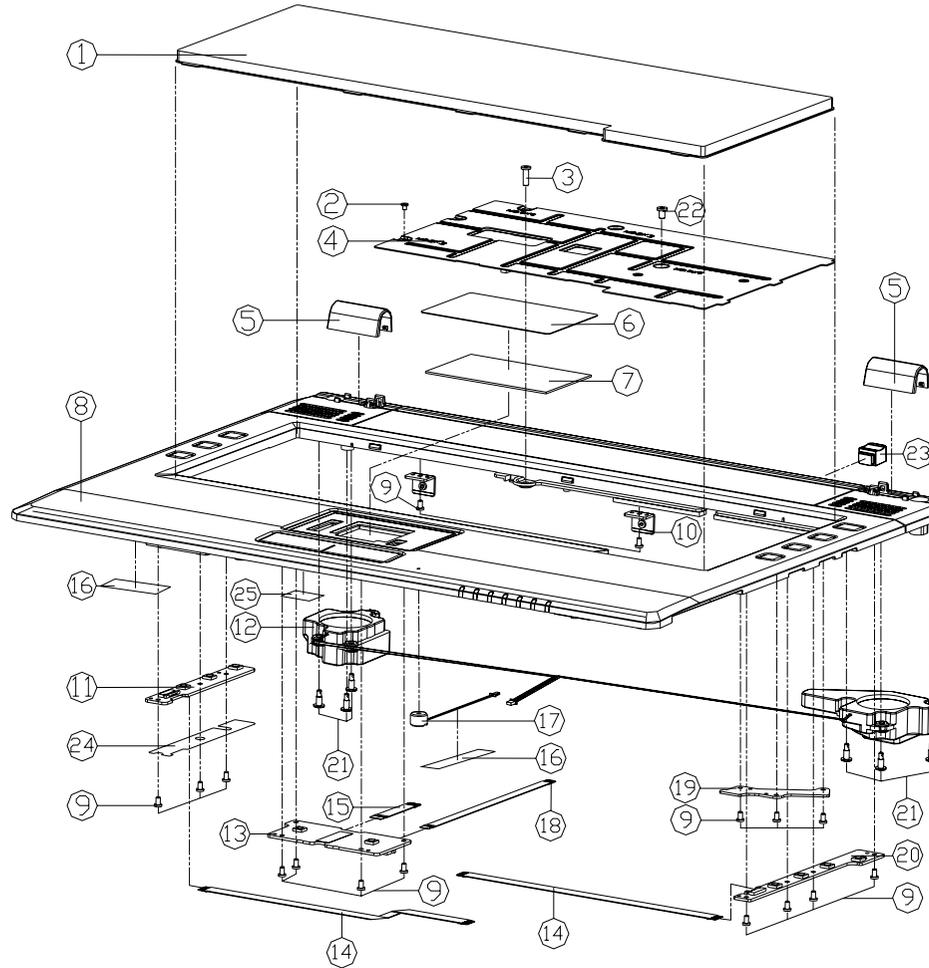

ITEM	PART NAME	PART NO	REMARK
1	KEYBOARD(OPTION)	6-80-M55G0-011-1	
2	SCREW M2x3L KI NI ICT GTY-PATCH 無鉛	6-35-B1120-3RE	
3	SCREW M2.5x5L KI BK/Z NY ICT 無鉛	6-35-B6125-8R0	
4	KEYBOARD SHIELDING M660JE 無鉛	6-33-M66E7-010	
5	HINGE COVER FOR M665N 無鉛	6-42-M6652-010	
6	TOUCH PAD MYLAR (C) MYLAR M550J 無鉛	6-40-M55G2-025	
7	TOUCH PAD TM61P021R389 M660JE 無鉛	6-49-M66E2-010	
8	TOP CASE MODULE M665N 無鉛	6-39-M6652-014	
9	SCREW M2x3L KI NI ICT NY 無鉛	6-35-B1120-3RA	
10	REAR REINFORCE BRACKET 無鉛	6-33-M66N2-031	
11	HOTKEY LT BOARD	6-77-M66NS-D11	
12	SPEAKER L/R 25x10x8 15W 40MM 183MM/240M	6-23-5M66N-012	
13	CLICK BOARD W/O FP V1.0	6-77-M66U2-001-1	
14	FFC CABLE FOR PWR-HOTKEY 6P PITCH=0.5	6-43-M66N0-010	
15	FFC CABLE FOR TOUCHPAD BOARD 12P PITCH=0.5	6-43-M66N0-030	
16	TAPE MYLAR (C) MYLAR M550J 無鉛	6-40-M55G2-030	
17	MICPHONE 08x13.5x6x2.5-TOL-10 10V-2V 22K	6-23-EM55G-010	
18	FFC CABLE FOR CLICK BOARD 4P PITCH=0.5	6-43-M66N0-020	
19	CABLE ALIGN BRACKET 無鉛	6-33-M66N2-040	
20	POWER HOT BOARD	6-77-M66NS-D01	
21	SCREW FOR SPEAKER M2 無鉛	6-35-Z0220-000	
22	SCREW M2.5x5L KI BK/Z ICT NY 無鉛	6-35-B6125-5RA	
23	MINI-1394 RUBBER 無鉛	6-47-M66SP-010	
24	MYLAR 08-83.7x12x11.1 0.55MM (R 75P) M660N 無鉛	6-40-M66NS-090	
25	TOUCH PAD GROMMET A TOL=0.2x4.0 FOR 08A M55G 無鉛	6-47-M55G2-020	

Bottom (M660SE/M665SE)

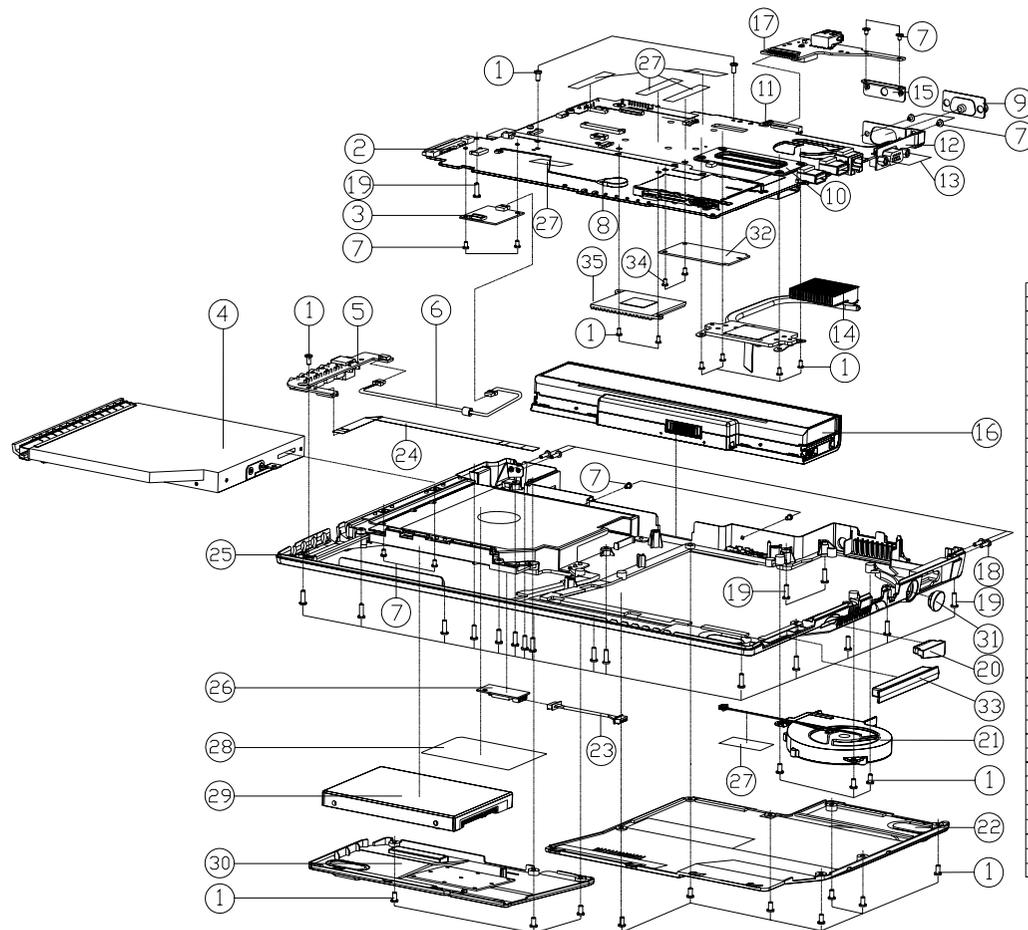

ITEM	PART NAME	PART NO.	REMARK
1	SCREW M2x4 KI BK/Z ICT NY	6-35-B6125-50A	
2	MAIN BOARD V.D20 M660SE	6-77-M660-D02	
3	MOUSE 12 PIN OUTDIOLA SOLUTION M.204 G	6-88-M6651-620	
3	MOUSE AZULM-457 12 PIN OUTDIOLA SOLUTION	6-88-M5551-531	
4	DIVIDUAL HV ISUPER MULTI BK OSE	6-79-M660D-040	
4	DIVIDUAL HV ISUPER MULTI BK OSE	6-79-M660D-010	
4	CORD 24X 155L462P ASSY M660SU	6-79-M660X-010	
4	CPHY PIV 24 PINS/CONDUCTOR ASSY MAIN	6-79-M660X-000	
5	MOUSE BOARD V.D20 M660SU	6-77-M660B-D01	
6	MOE CABLE 2P AWG30 M660N	6-43-M660N-050	
7	SCREW M2x4 KI NI ICT EXT-PATCH	6-35-B1120-3RE	
8	SH. 20M 2Y 23MM W/CABLE 4MM COX2026	6-23-22015-P39	
9	SERIAL-PORT RUBBER	6-47-M665S-011	
10	CPU SUPPORTER M660N	6-33-M66NS-030	
11	REINFORCE BRACKET/LIN UP SERIAL B	6-33-M66NS-001	
12	L/D BRACKET 7 FDR M/B	6-33-M66NS-011	
13	HEX STUD SLANGE IN-HE 10mm NY	6-34-96002-00A	
14	CPU HEATSINK MOBILE M660	6-31-M665N-101	
15	SERIAL-PORT BRACKET NY	6-33-M665S-020	
16	BAYO.SLL 40ML3CP7P M660LQ /PA	6-87-M66NS-453	
16	BAYO.SLL 40ML3CP7P M660LQ /PA	6-87-M66NS-4C3	
17	USB BOARD V.D20 M660SU	6-77-M660J3-D02	
18	SCREW M2x4 KI BK/Z ICT NY	6-35-B6120-8R0	
19	SCREW M2x4 KI BK/Z NY ICT	6-35-B6125-8R0	
20	CARD READER RUBBER COVER	6-47-M66NE-010	
21	CPM MOBILE	6-31-M66NS-204	
22	CPM COVER MOBILE M660	6-42-M66E3-103	
23	BLUE TOOTH CABLE 1P AWG30 M660N	6-43-M66NB-010	
24	ITC CABLE FOR AUDIO JACK BOARD TOP PITCH	6-43-M66ND-041	
25	MAIN BOARD V.D20 M660SU	6-77-M660J3-D02	
26	BLUE TOOTH 28 P PIN MOBILE QUICKCHG BLL	6-88-M55J5-390	
27	TAPE NYLAR (C)NYLAR MO50J	6-40-M55J5-030	
28	PRODUCT LABEL FOR M665SE	6-45-M6E53-010	
28	PRODUCT LABEL FOR M665SE	6-45-M6E63-010	
29	L/D HARD ASSY M660N	6-79-M66N-010	
30	MOB COVER MOBILE	6-42-M66NJ-103	
31	T V-CUT RUBBER	6-47-M66S3-010	
32	BREIT 18G MINI CARBOSIS REAL EX CHIPSE	6-88-M7702-701	
33	RUBBER COVER FOR NEW CARD SOCKET	6-47-M66N3-020	
34	SCREW M2x4 KI BNI ICT NY	6-35-B9120-4RA	
35	HEAT SINK FOR NORTH BRIDGE M660SU	6-33-M6E6N-010	

Figure A - 3
Bottom (M660SE/
M665SE)

A.Part Lists

LCD (M660SE/M665SE)

Figure A - 4
LCD (M660SE/
M665SE)

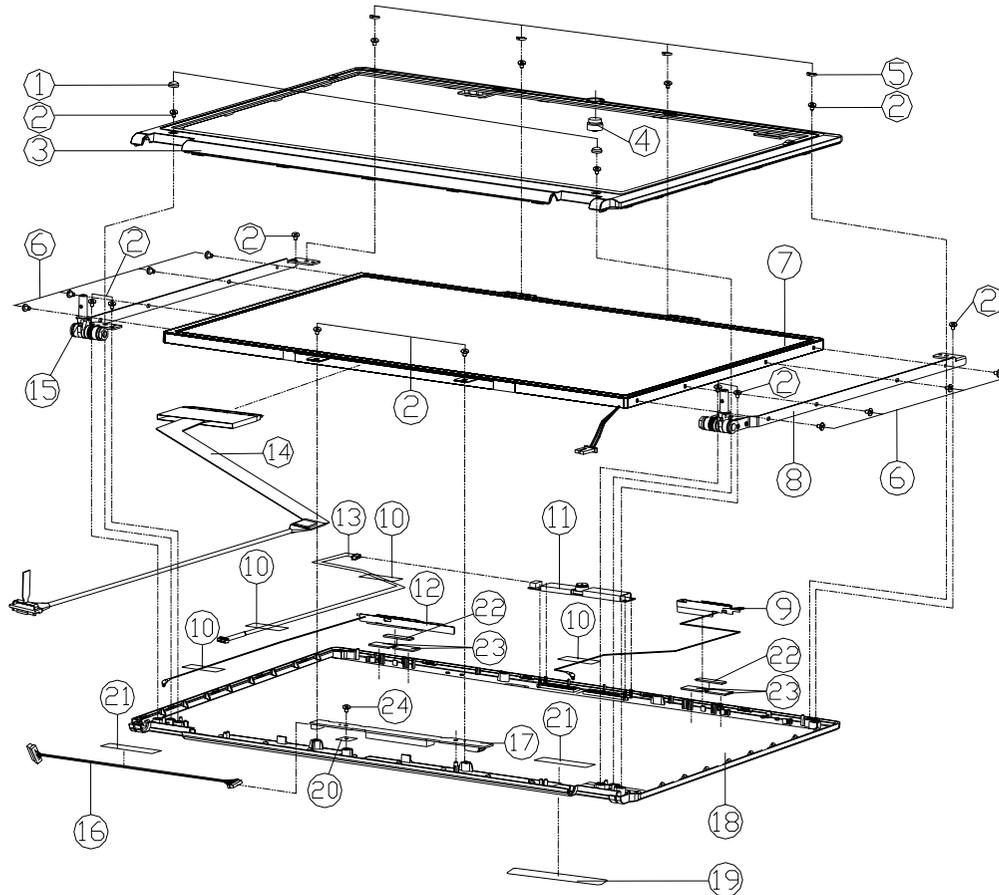

ITEM	PART NAME	PART NO	REMARK
1	LCD RUBBER	6-47-M56A1-010	
2	SCREW M2.5XSL KI NI ICT NY	6-35-B6125-SRA	
3	LCD FRONT COVER MODULE	6-39-M66NI-012	
4	V/D CCD RUBBER/RUBBER M550G	6-47-M55GT-020	
5	LCD RUBBER Ø6	6-47-M66NI-030	
6	SCREW M2XSL KI NI ICT G11-PATCH	6-35-B1120-3RE	
7	LCD T AU BUSH/WOLCARE TYPE V9 15.4" WX	6-50-L8262-G00	FOR AU
7	LCD T OPT CLAM/WOLCARE TYPE V9 15.4" WX	6-50-L8262-C00	FOR CPT
8	LCD HINGE ASSY R M660N	6-33-M66NI-011	
9	MONITOR ANTENNA WITH REDD CABLE AND PEK CONNECT	6-23-7M66NI-024	
10	TAPE MYLAR (C)MYLAR M550J	6-40-M55J2-030	
11	CHG VIDEO CAMERA BNC-DV960-D 30X PIXEL	6-88-M66NC-491	(OPTION)
11	CHG VIDEO CAMERA BNC-DV960-D 5MG 13M	6-88-M55GC-612	(OPTION)
12	M660N BT ANTENNA WITH GRAY CABLE AND IPEX	6-23-7M66NI-013	
13	CCD CABLE SP AWG30 M660N-D04	6-43-M66NI-062	
14	WIRE CABLE FOR ISL V9/V9S/9A/9M/9P/9S/9T/9U/9V/9W/9X/9Y/9Z	6-43-M66UI-010	
15	LCD HINGE ASSY L M660N	6-33-M66NI-021	
16	MONITOR FLAG	6-43-M66NI-053	
17	INVERTER MODULE FOR M660S	6-76-M66SR-011	
17	INVERTER MODULE IS166-1R EPS M660E	6-76-M66SR-010	
18	LCD BACK COVER MODULE	6-39-M66NI-024	FOR M660SU/SE
18	LCD BACK COVER MODULE (ROSS ADD RIB)	6-39-M6651-023	FOR M665SU/SE
19	FOR M550G LOGO/STYLE-NOTE	6-45-M55G1-020	
20	MYLAR FOR INVERTER (44X10.4X4) M660N	6-40-M66NS-060	
21	TAPE MYLAR (A)MYLAR M550J	6-40-M55J2-010	
22	SPONGE 4.33X3.5X0.65MM	6-47-M6651-010	
23	SPONGE 4.82X4.10X1.65	6-47-M6651-020	
24	SCREW M2X3SL KI NI ICT NY	6-35-B1120-350	

CDRW (M660SE/M665SE)

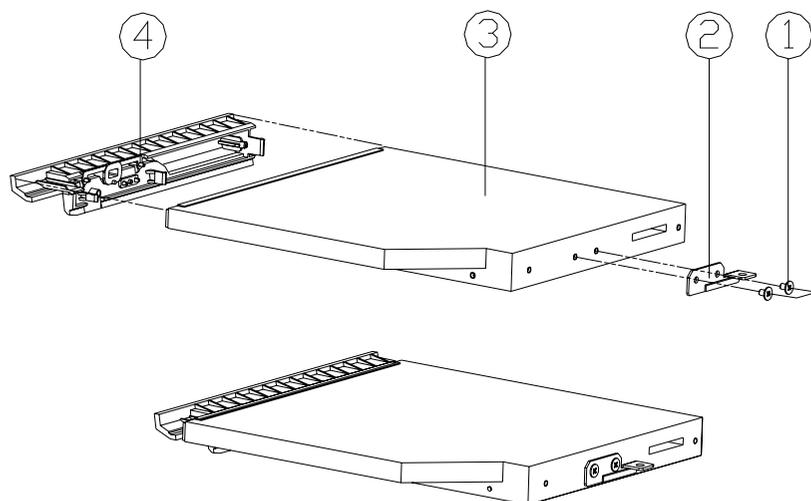
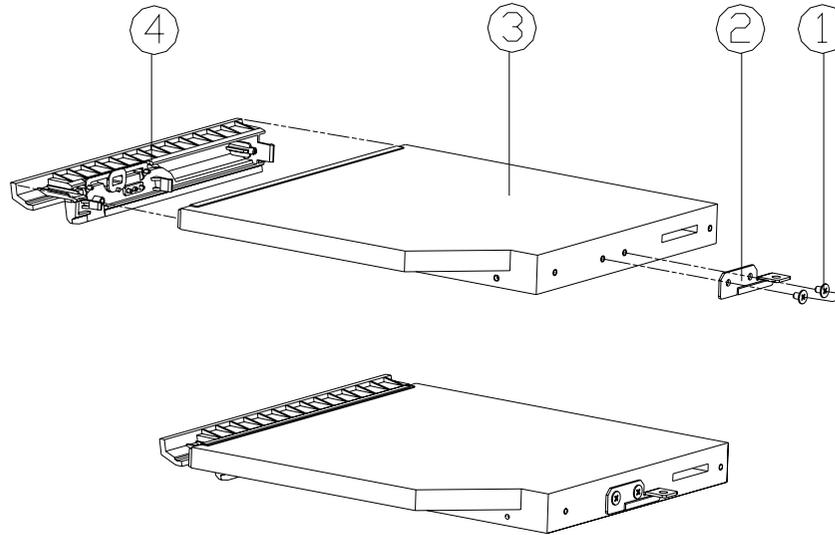

Figure A - 5
CDRW (M660SE/
M665SE)

ITEM	PART NAME	PART NO	REMARK
1	SCREW M2*3L K1 NI ICT GTY-PATCH	6-35-B1120-3RE	
2	DDD FIX BRACKET M660N	6-33-M66NZ-010	
3	CD-RW/DVD 5 1/4" 24X 12.7MM UJDA770CL-A	6-85-907PX-P00	
3	CD-RW/DVD 5 1/4" 24X 12.7MM SCB5265 PHILIP	6-85-907PX-C02	
4	G BEZEL MODULE FOR DVD COMBO	6-42-M66NX-101	

Combo (M660SE/M665SE)

Figure A - 6
Combo (M660SE/
M665SE)



ITEM	PART NAME	PART NO	REMARK
1	SCREW M2*3L KI NI ICT GTY-PATCH	6-35-B1120-3RE	
2	DDD FIX BRACKET M660N	6-33-M66NZ-010	
3	CD-RW/DVD 5 1/4" 24X 12.7MM TS-L462D	6-85-907PX-T01	
4	G BEZEL MODULE FOR DVD COMBO	6-42-M66NX-101	

DVDRW (M660SE/M665SE)

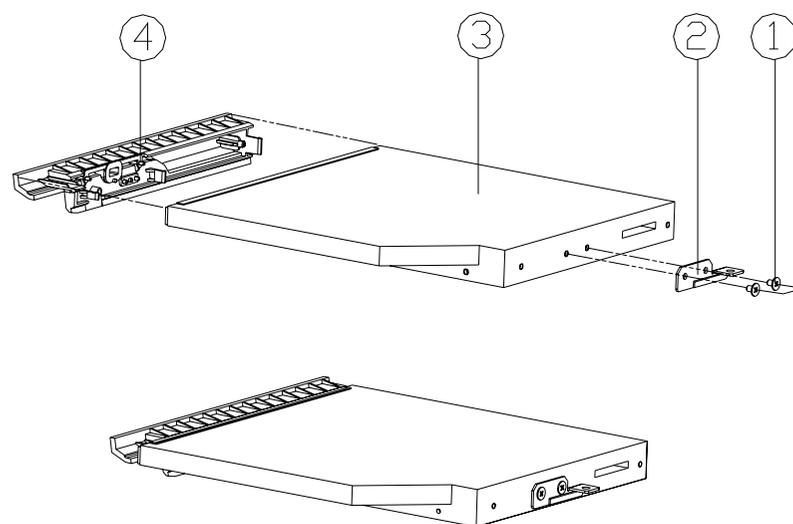

Figure A - 7
DVDRW (M660SE/
M665SE)

ITEM	PART NAME	PART NO	REMARK
1	SCREW M2*3L K1 NI ICT GTY-PATCH	6-35-B1120-3RE	
2	ODD FIX BRACKET M660N	6-33-M66NZ-010	
3	DVD/DUAL RW 5 1/4" 8X 12.7MM TS-L632D	6-85-A078X-T02	FOR TSST
3	DVD/DUAL RW 5 1/4" 8X 12.7MM AD-7530MSUPER MULTID SMDGSD	6-85-A078X-C06	FOR QSI
4	DVD DUAL/SUPER MULTID G-BEZEL MODULE FOR M660N	6-42-M66NQ-A00	

Appendix B:Schematic Diagrams

This appendix has circuit diagrams of the *M660SE/M665SE* notebook's PCB's. The following table indicates where to find the appropriate schematic diagram.

Diagram - Page	Diagram - Page	Diagram - Page
<i>SYSTEM BLOCK DIAGRAM - Page B - 2</i>	<i>VT8237A-1 - Page B - 16</i>	<i>CHARGER, DC IN - Page B - 30</i>
<i>CLOCK GENERATOR - Page B - 3</i>	<i>VT8237A-2 - Page B - 17</i>	<i>1.05VS, 1.5V, 2.5VS - Page B - 31</i>
<i>CPU-1 - Page B - 4</i>	<i>VT8237A-3 - Page B - 18</i>	<i>VCORE - Page B - 32</i>
<i>CPU-2 - Page B - 5</i>	<i>HDD & CDROM - Page B - 19</i>	<i>1.8V, 0.9VS - Page B - 33</i>
<i>VN896-1 - Page B - 6</i>	<i>CARD READER - Page B - 20</i>	<i>VDD3, VDD5 - Page B - 34</i>
<i>VN896-2 - Page B - 7</i>	<i>NEW CARD SOCKET - Page B - 21</i>	<i>EXT GPU 1.0VS/1.2VS - Page B - 35</i>
<i>VN896-3 - Page B - 8</i>	<i>LAN - Page B - 22</i>	<i>HOTKEY LT BOARD - Page B - 36</i>
<i>VN896-4 - Page B - 9</i>	<i>USB & CCD - Page B - 23</i>	<i>PWR HOT BOARD - Page B - 37</i>
<i>DDR2-1 - Page B - 10</i>	<i>HITACHI H8 - Page B - 24</i>	<i>AUDIO & MODEM BOARD - Page B - 38</i>
<i>DDR2-2 - Page B - 11</i>	<i>CRT & LVDS - Page B - 25</i>	<i>CLICK BOARD - Page B - 39</i>
<i>VGA G72M-1 - Page B - 12</i>	<i>CPU FAN, LPC ROM - Page B - 26</i>	<i>USB BOARD - Page B - 40</i>
<i>VGA G72M-2 - Page B - 13</i>	<i>MINI-PCI & BLUETOOTH - Page B - 27</i>	<i>FINGERPRINT BOARD - Page B - 41</i>
<i>VGA G72M-3 - Page B - 14</i>	<i>AUDIO VT1708A/ALC883 - Page B - 28</i>	
<i>VGA G72M-4 - Page B - 15</i>	<i>LED - Page B - 29</i>	

Table B - 1
**Schematic
Diagrams**



Version Note

The schematic diagrams in this chapter are based upon version 6-7P-M66U7-001. If your mainboard (or other boards) are a later version, please check with the Service Center for updated diagrams (if required).

SYSTEM BLOCK DIAGRAM

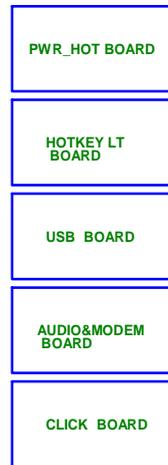

Sheet 1 of 40
SYSTEM BLOCK
DIAGRAM

M660SU BLOCK DIAGRAM

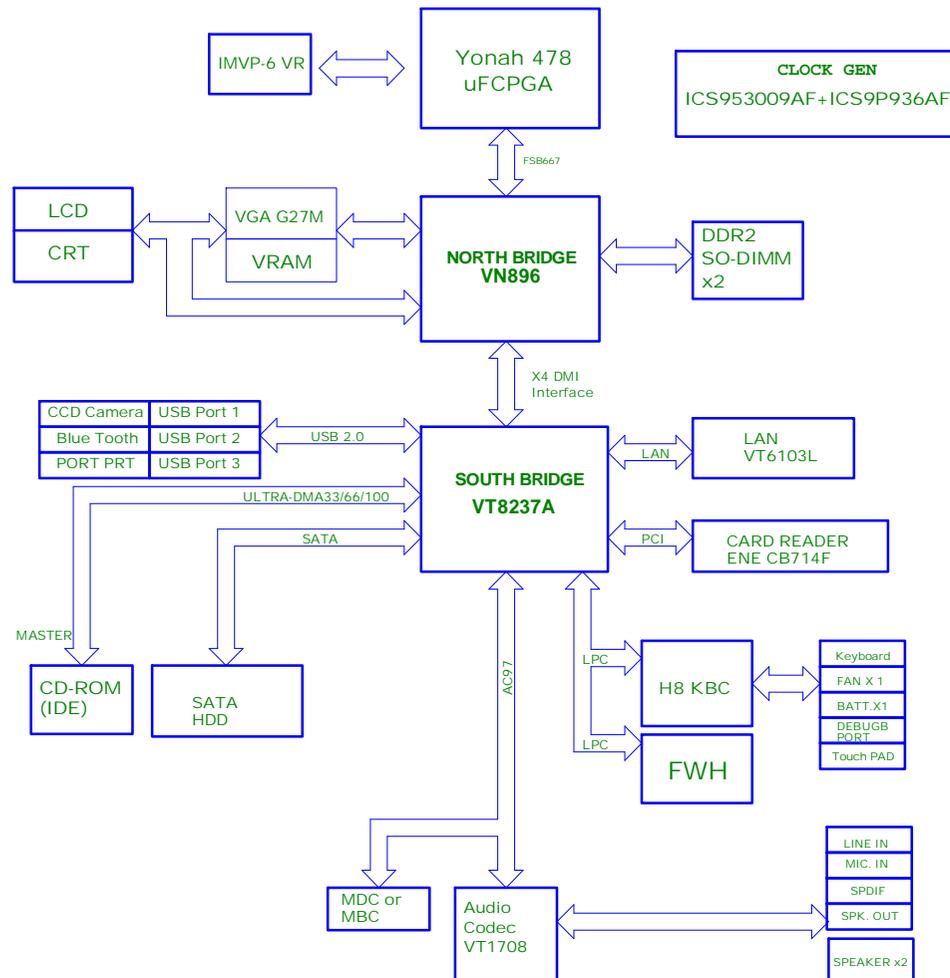

CLOCK GENERATOR

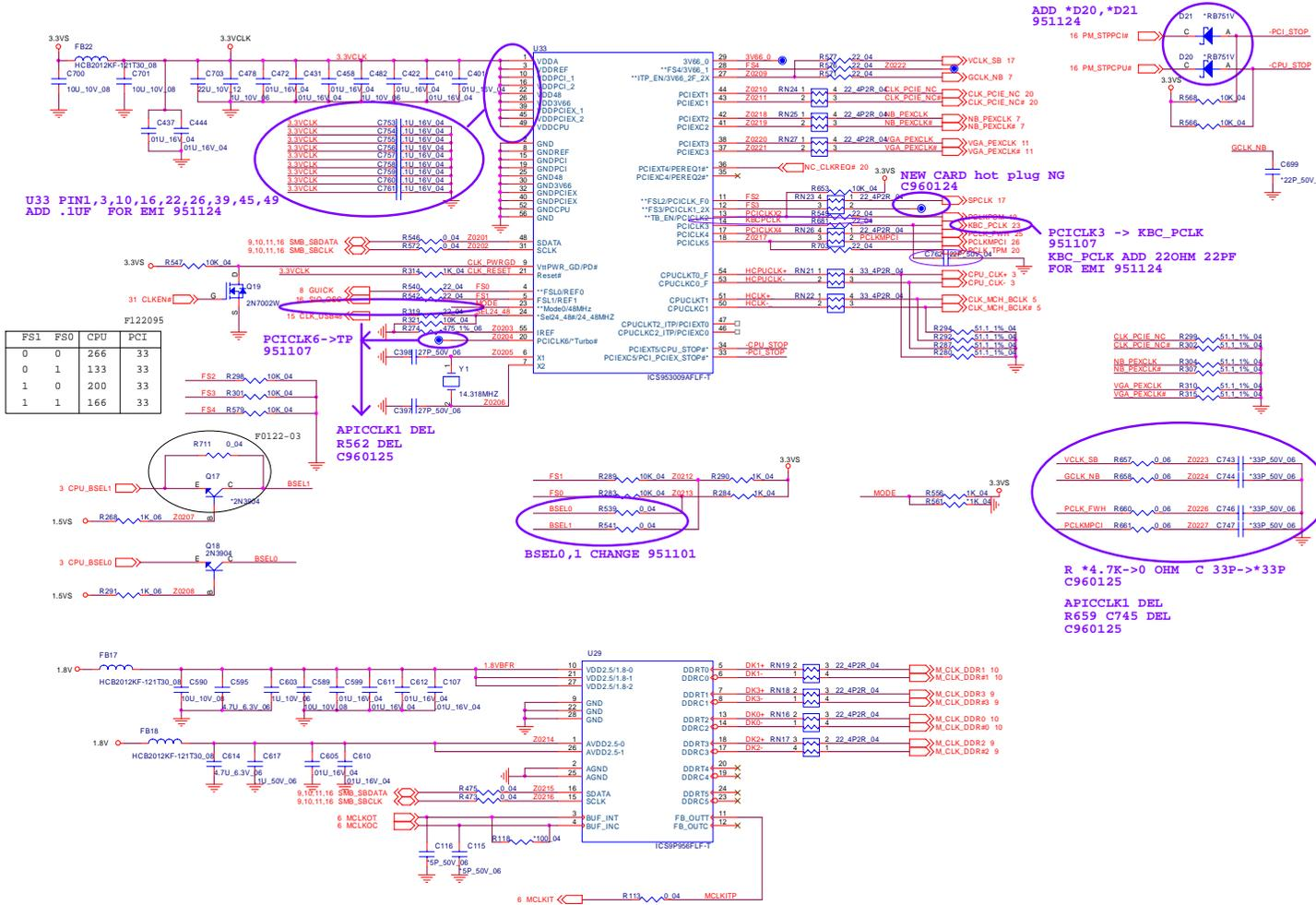

Sheet 2 of 40
CLOCK
GENERATOR

B.Schematic Diagrams

CPU-2

B. Schematic Diagrams

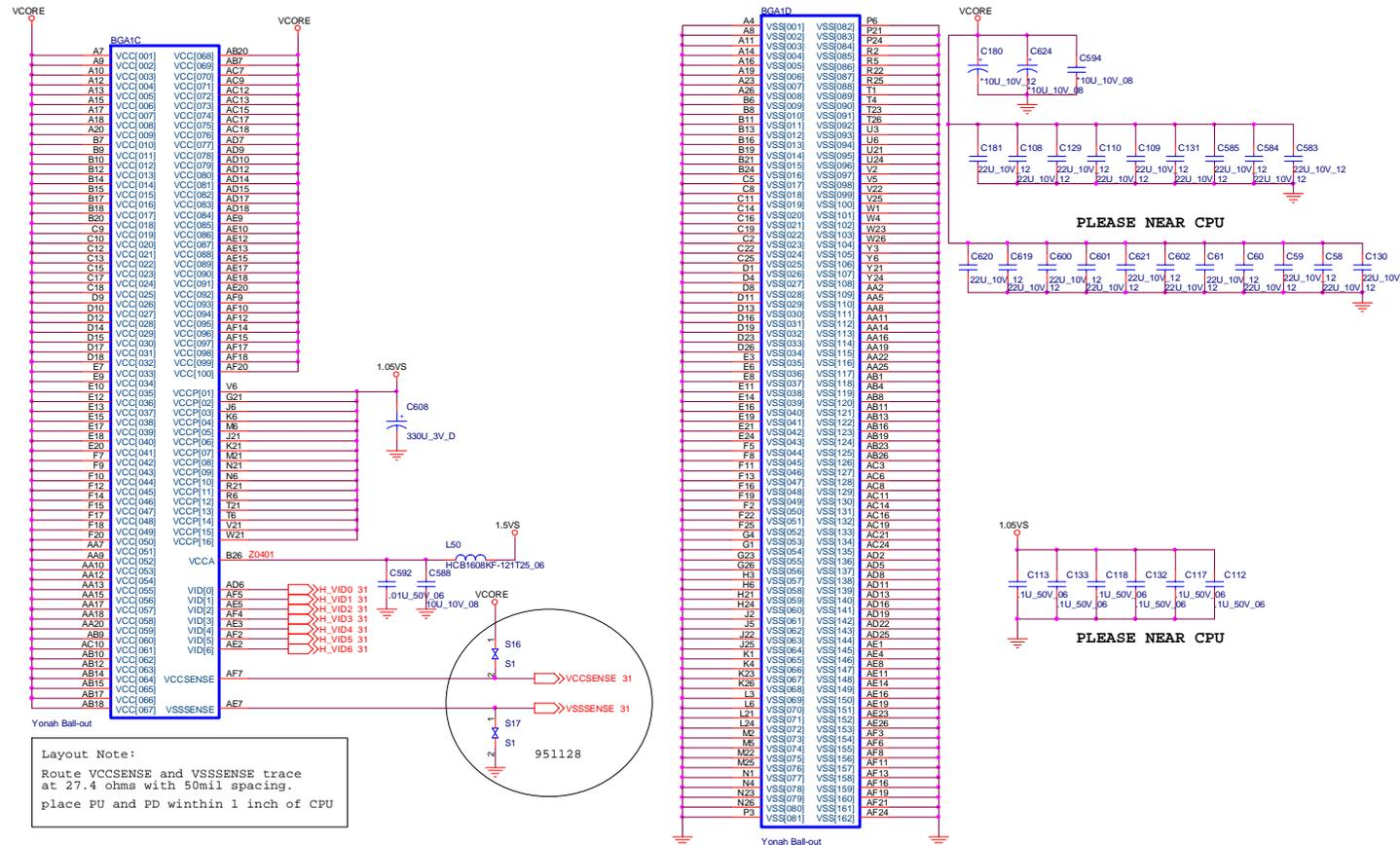

Sheet 4 of 40
CPU-2

Schematic Diagrams

VN896-1

B.Schematic Diagrams

Sheet 5 of 40
VN896-1

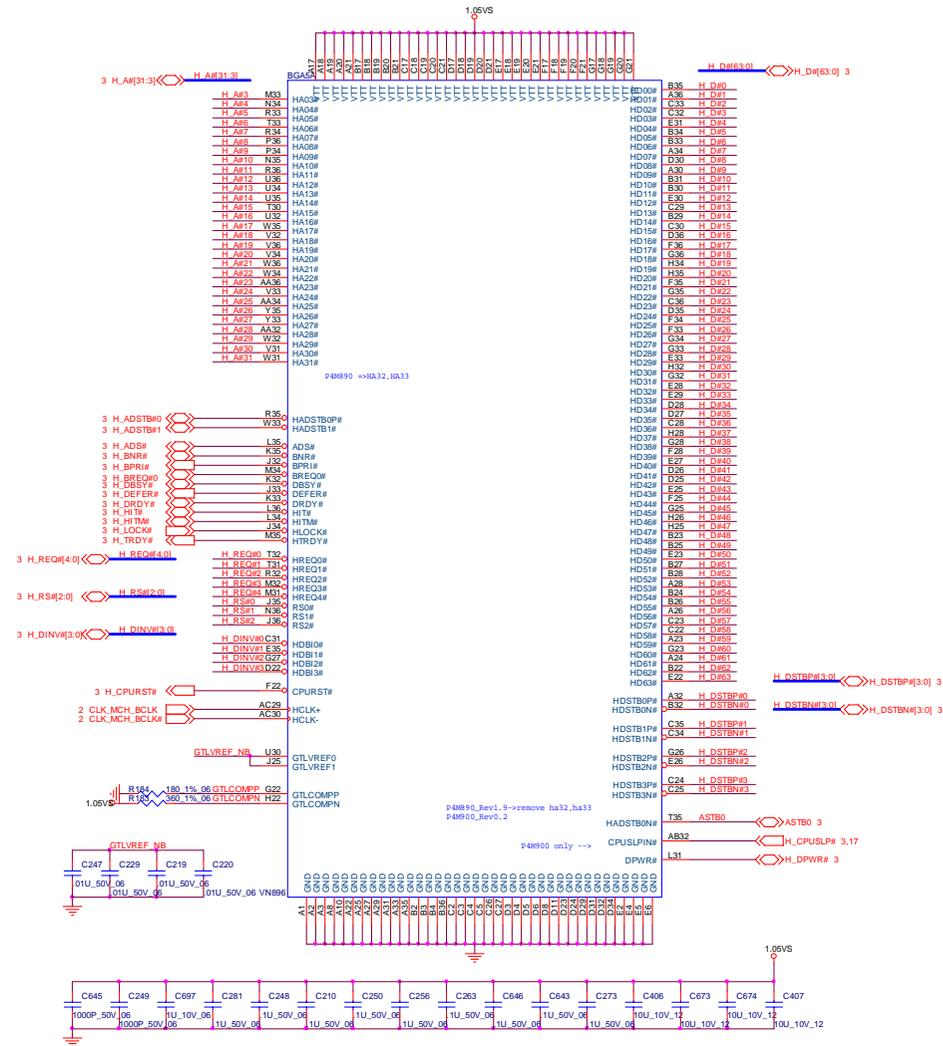

VN896-2

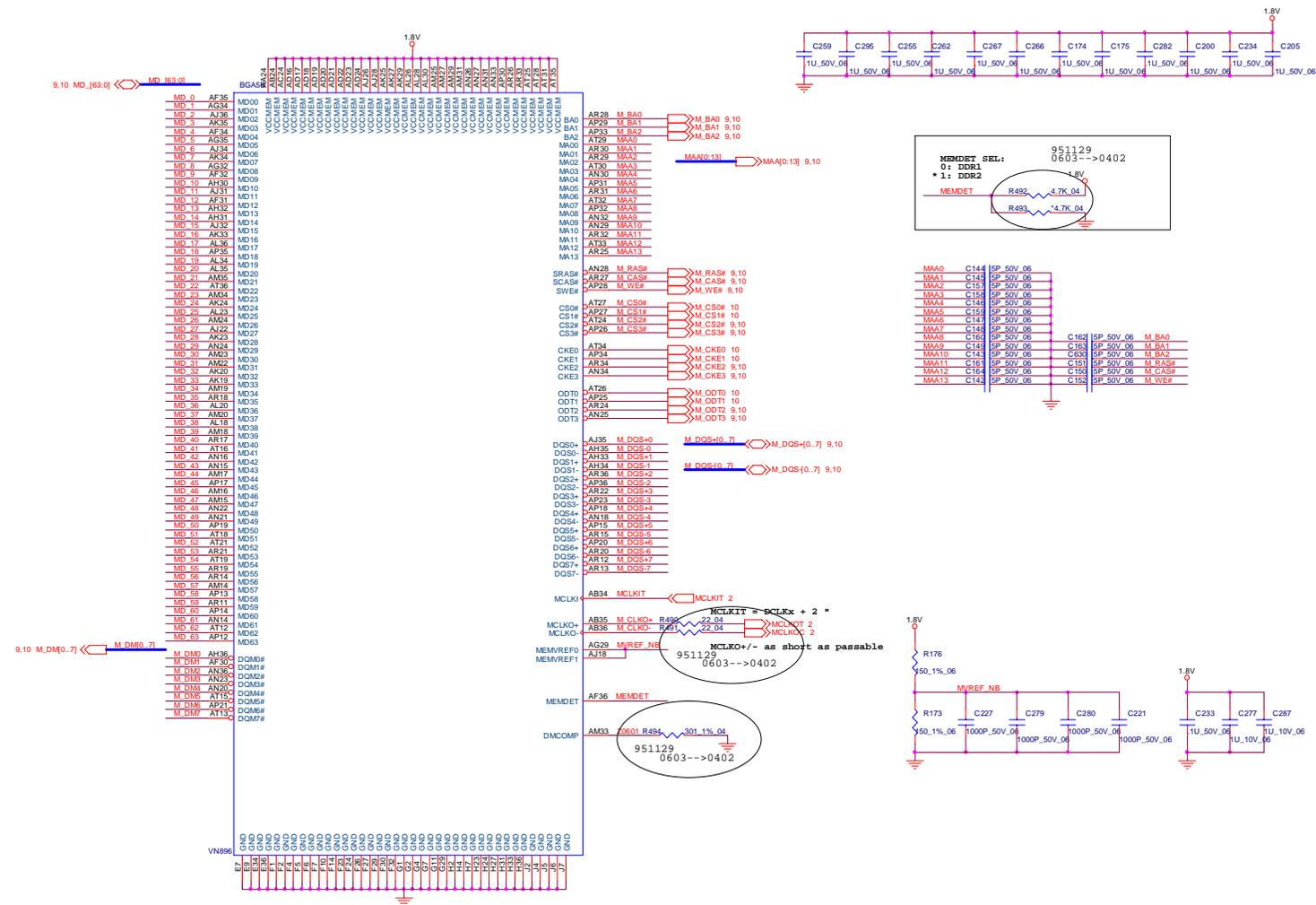

Sheet 6 of 40
VN896-2

B. Schematic Diagrams

VN896-4

B.Schematic Diagrams

Sheet 8 of 40
VN896-4

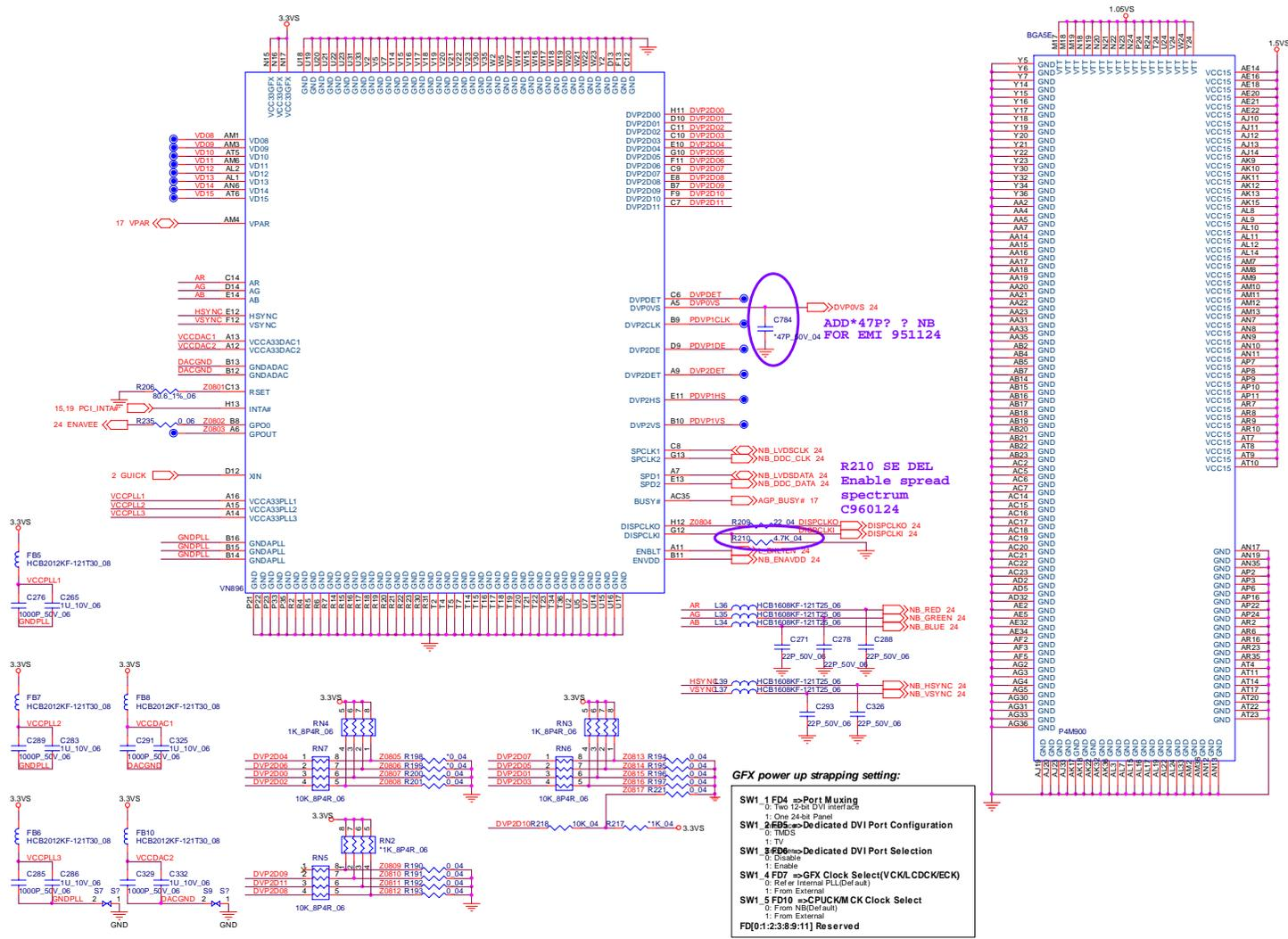

Schematic Diagrams

DDR2-1

Sheet 9 of 40
DDR2-1

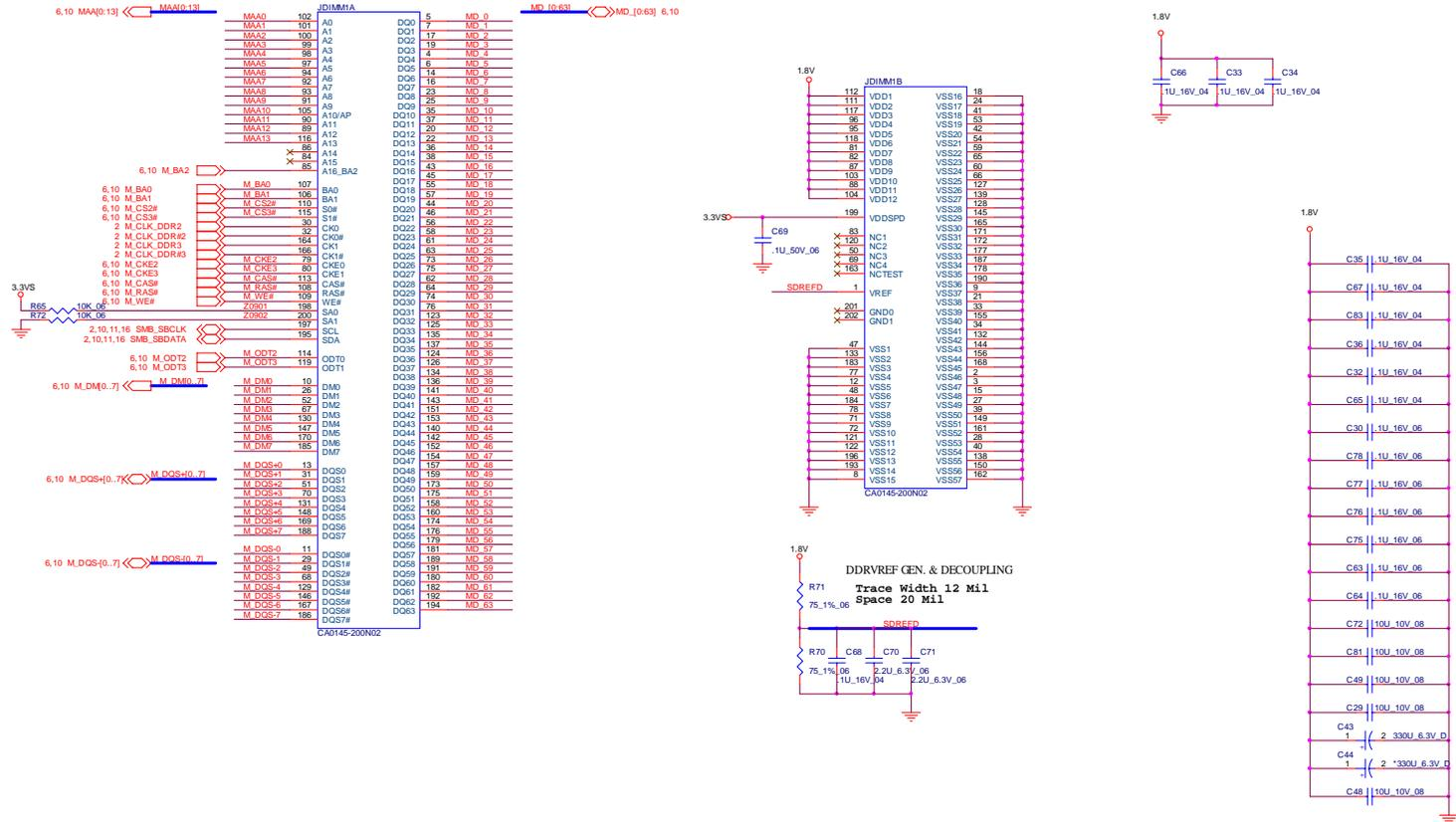

VGA G72M-1

Sheet 11 of 40
VGA G72M-1

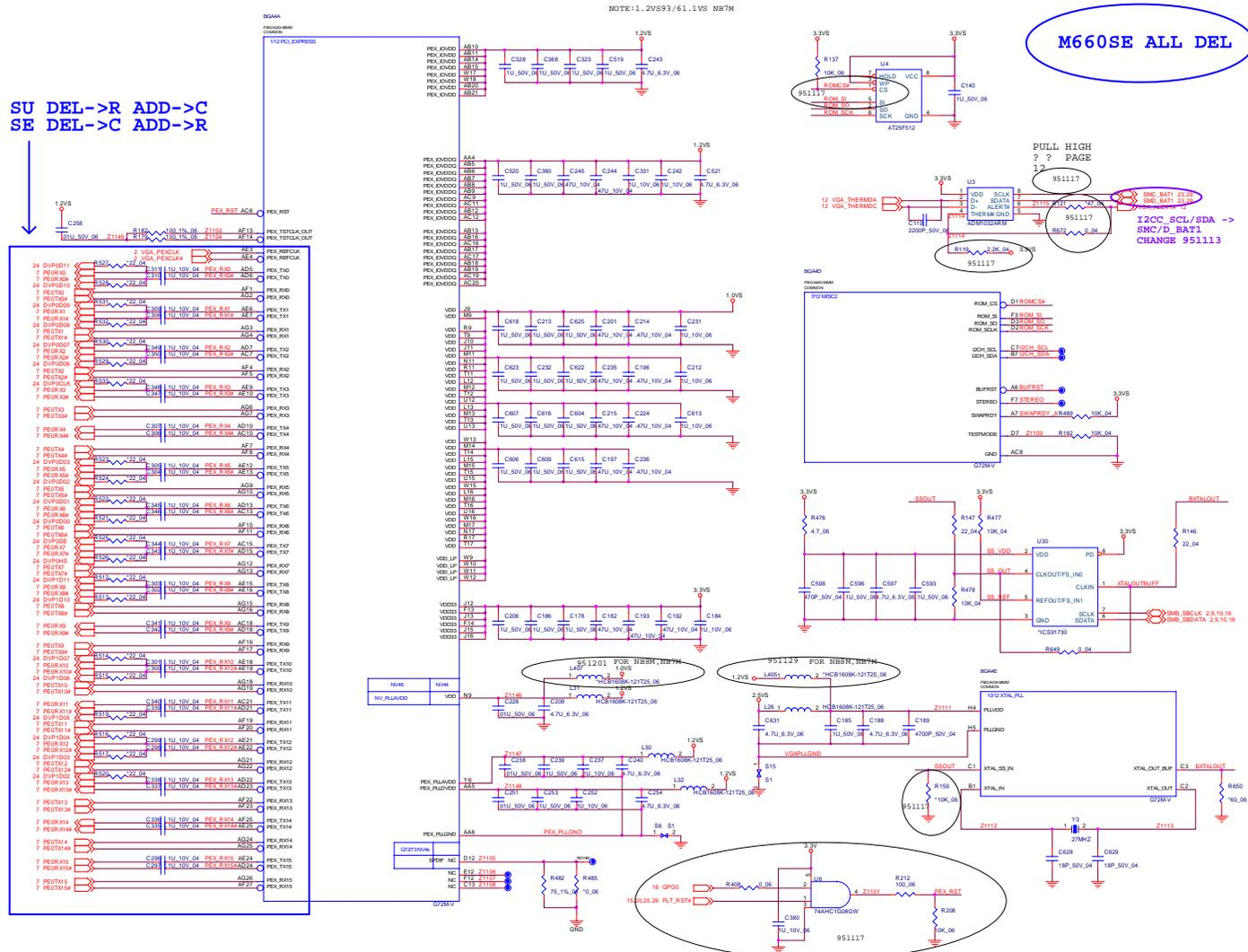

Schematic Diagrams

VGA G72M-3

M660SE ALL DEL

B.Schematic Diagrams

Sheet 13 of 40
VGA G72M-3

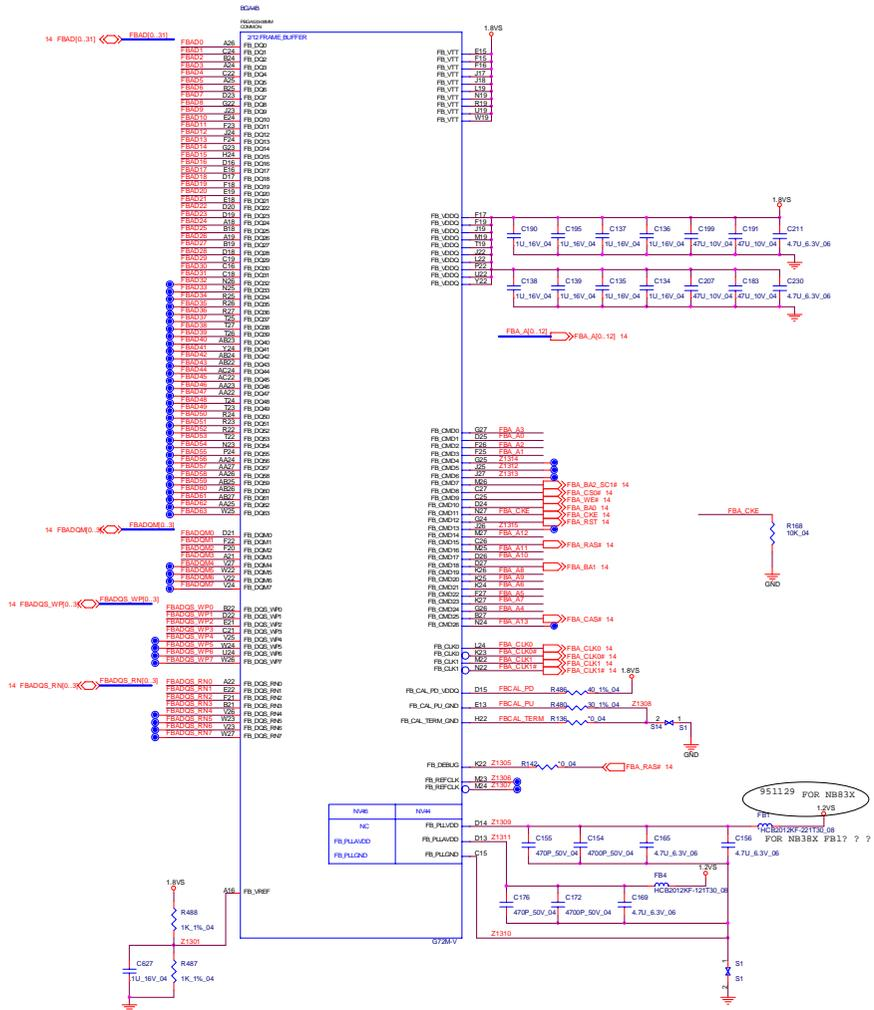

VGA G72M-4

M660SE ALL DEL

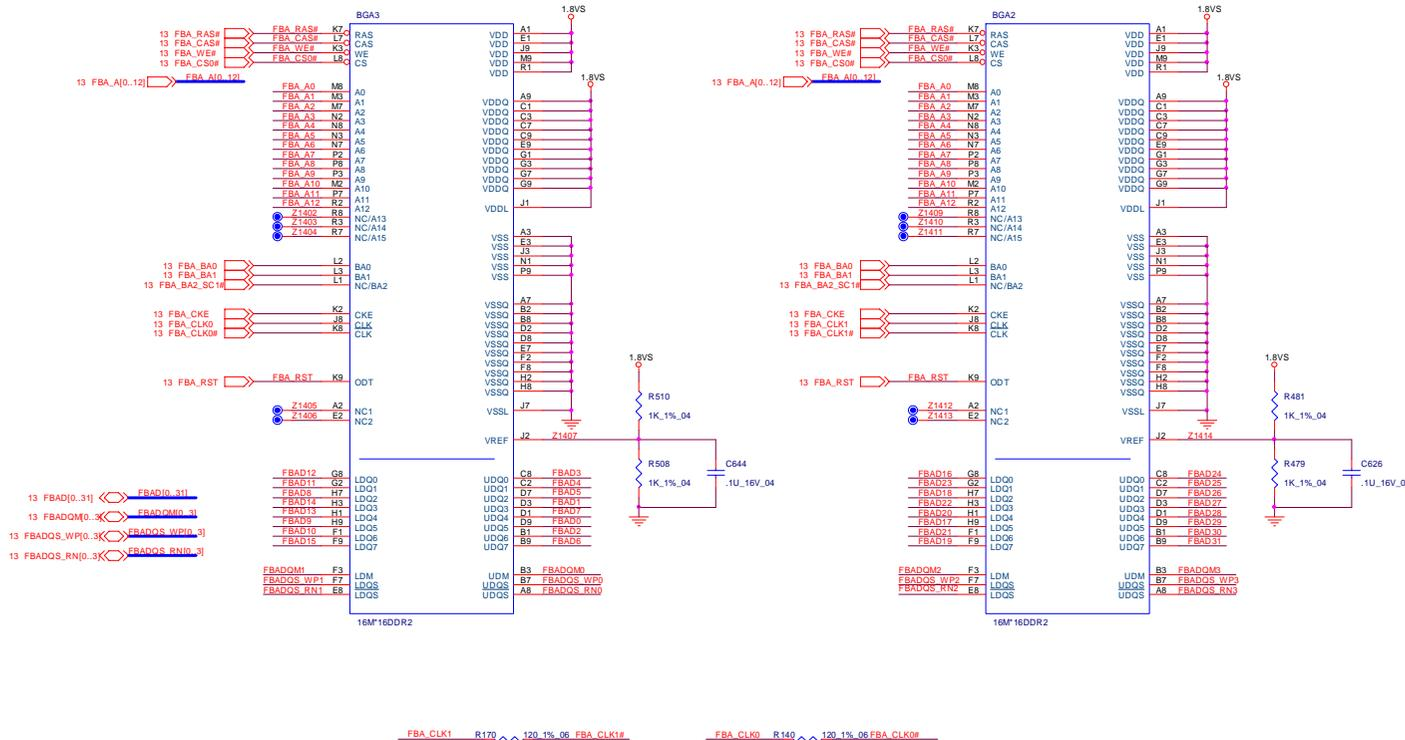

Sheet 14 of 40
VGA G72M-4

B.Schematic Diagrams

HDD & CDROM

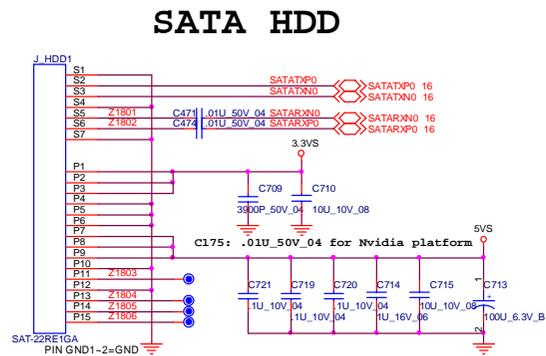

CD-ROM

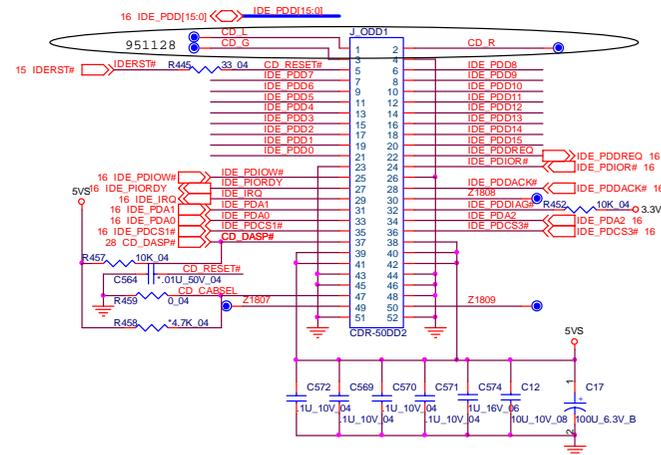

Layout note:
 CD_R & CD_G & CD_L must parallel routing to Audio Codec. The wide is 12mils and space must be equal.

To	Signal:Space = 1:2	Other Signal
AUDIO	Signal:Space = 1:1	CD_R
CODEC	Signal:Space = 1:1	CD_G
	Signal:Space = 1:2	CD_L
	Signal:Space = 1:2	Other Signal

Sheet 18 of 40
 HDD & CDROM

B.Schematic Diagrams

NEW CARD SOCKET

3 IN 1 SOCKET SD/MMC/MS(Pro)

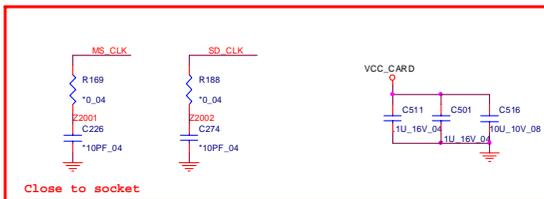
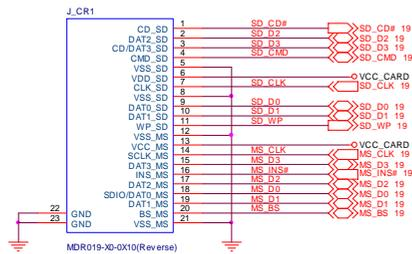

TPM 1.2

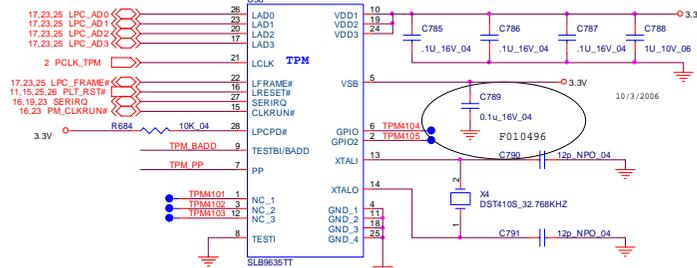

asserted before entering S3
LPC reset timing:
LPCPD# inactive to LRST# inactive 32-96us

TPM_PP	H : ACCESS LOW :	H : -4E/ME h LOW : ZE/ 2F h
TPM_BADD	NORMAL (Internal PD)	

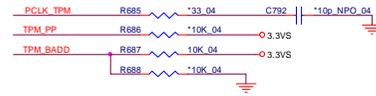

NEW_CARD_RST#-<=>BUF_PLT_RST# C960130

NEW CARD

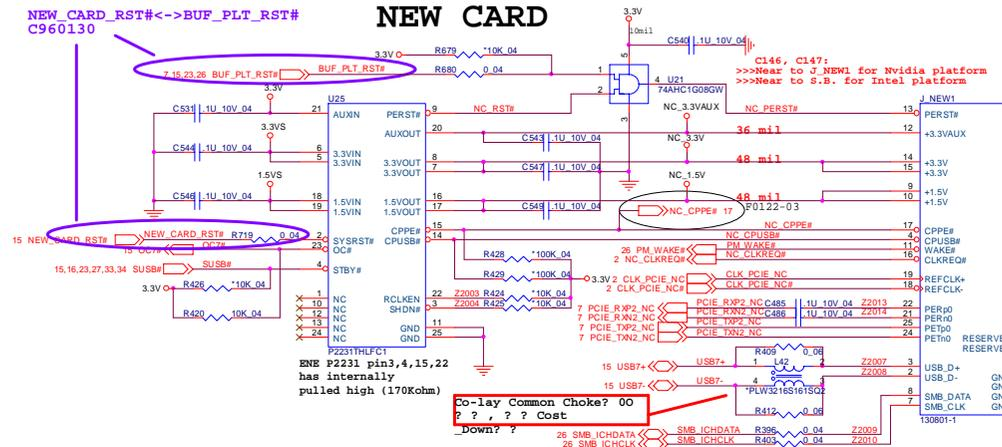

Card Reader Power

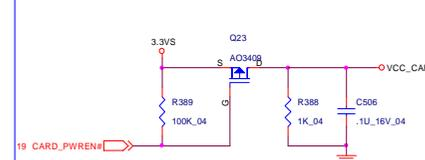

Sheet 20 of 40
NEW CARD
SOCKET

B.Schematic Diagrams

LAN

Sheet 21 of 40
LAN

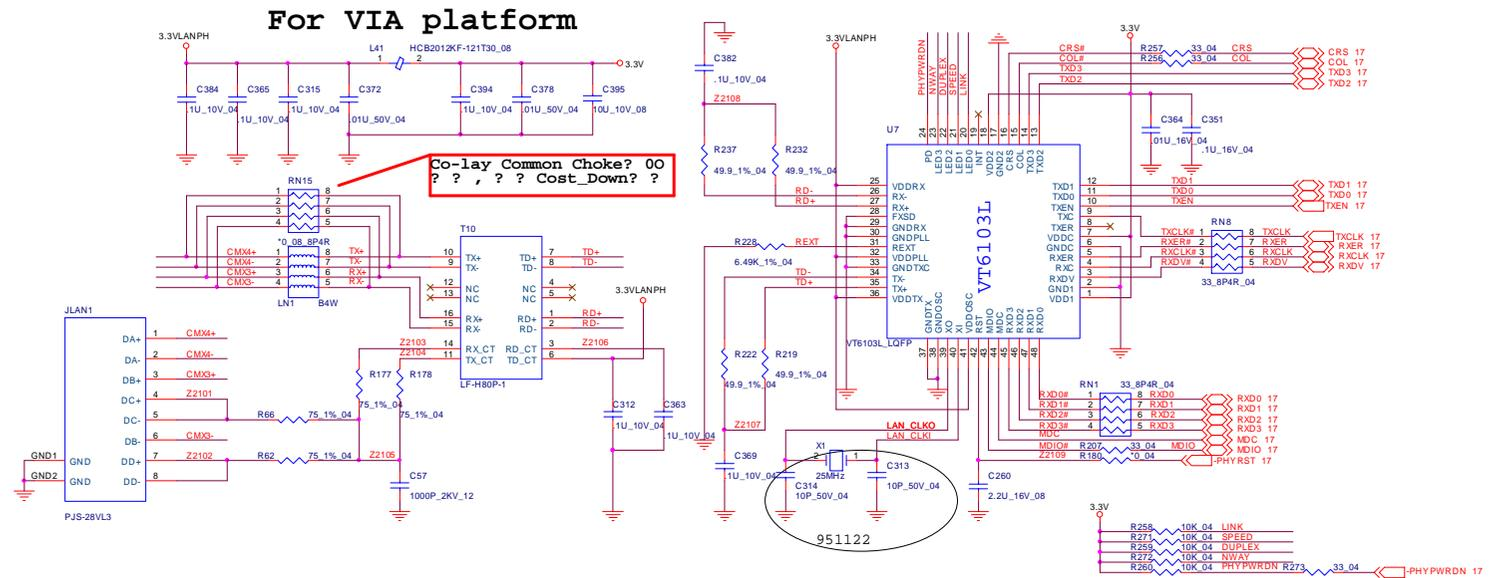

USB & CCD

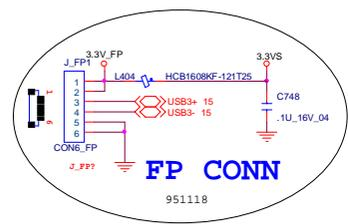
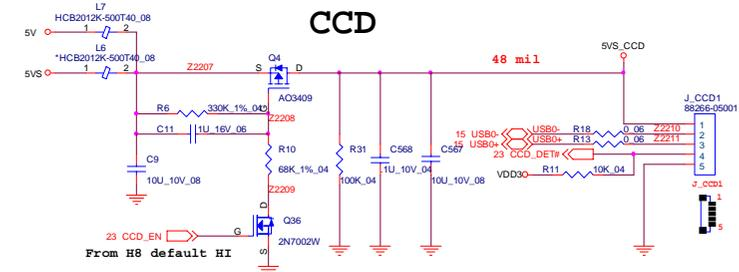
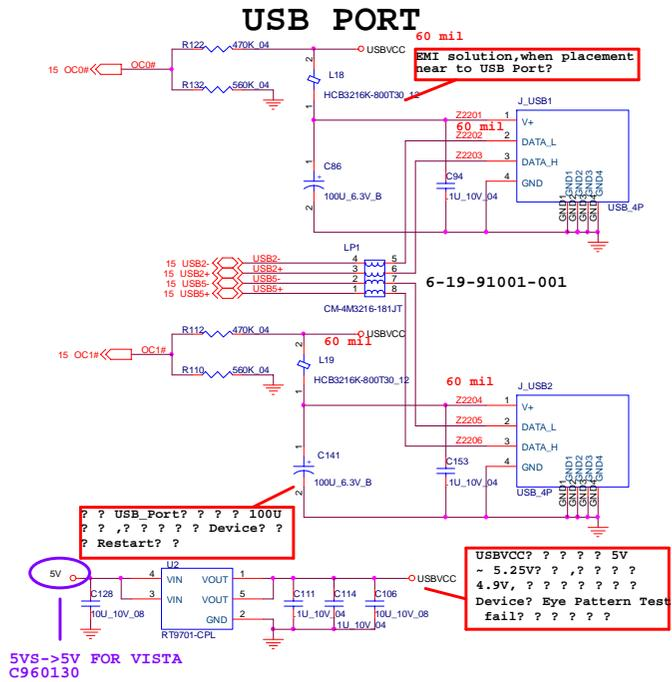

Sheet 22 of 40
USB & CCD

B. Schematic Diagrams

HITACHI H8

Sheet 23 of 40
HITACHI H8

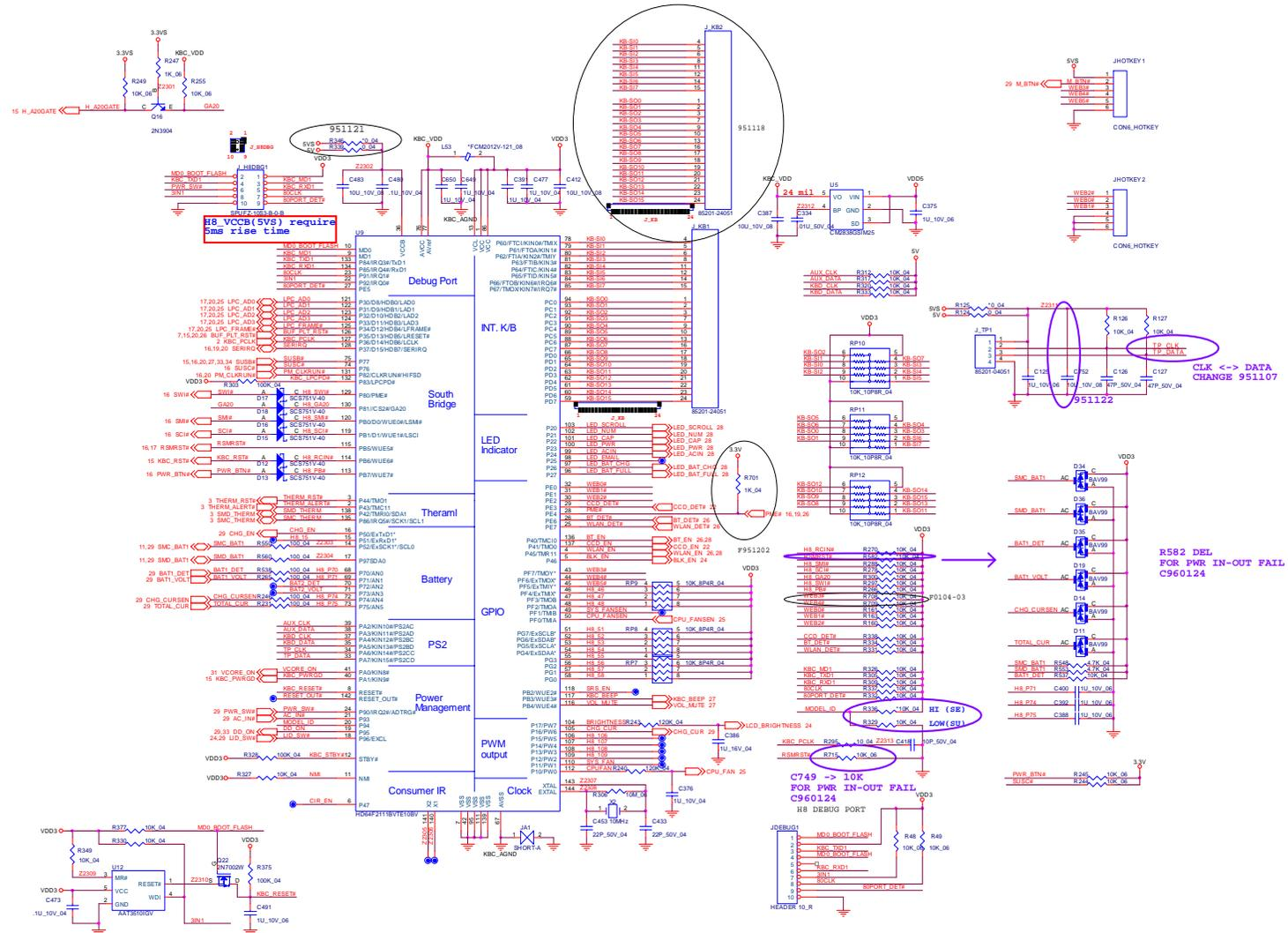

CRT & LVDS

PANEL INTERFACE

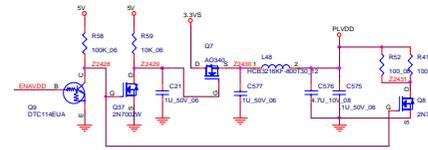
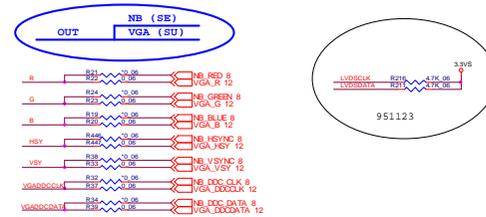
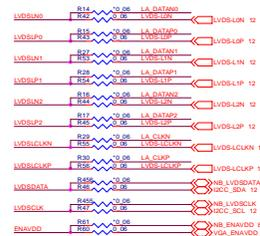
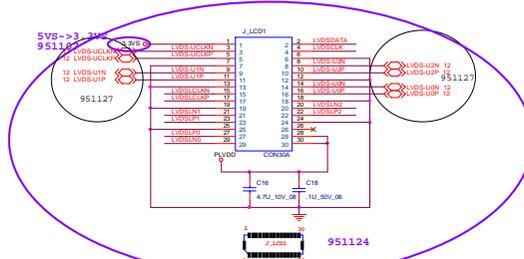

CPU FAN, LPC ROM

Sheet 25 of 40
CPU FAN,
LPC ROM

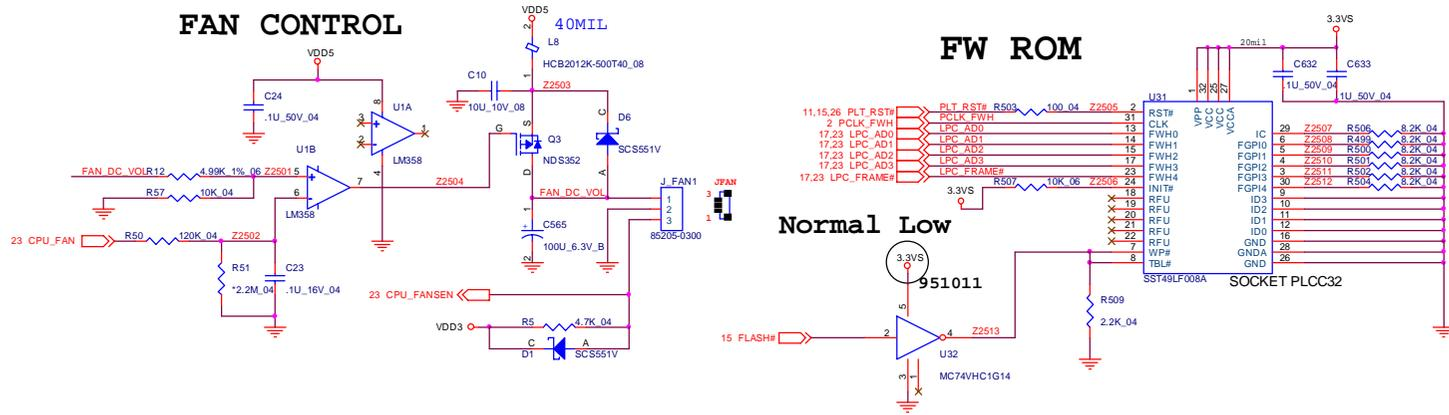

Normal Low

FWH_TBL#	FWH_WP#	Flash Mode
Low	Low	Protected
Low	High	Block 1-7
High	Low	Block 0
High	High	Block 0-7

AUDIO VT1708A/ALC883

B.Schematic Diagrams

Sheet 27 of 40
AUDIO VT1708A/
alc883

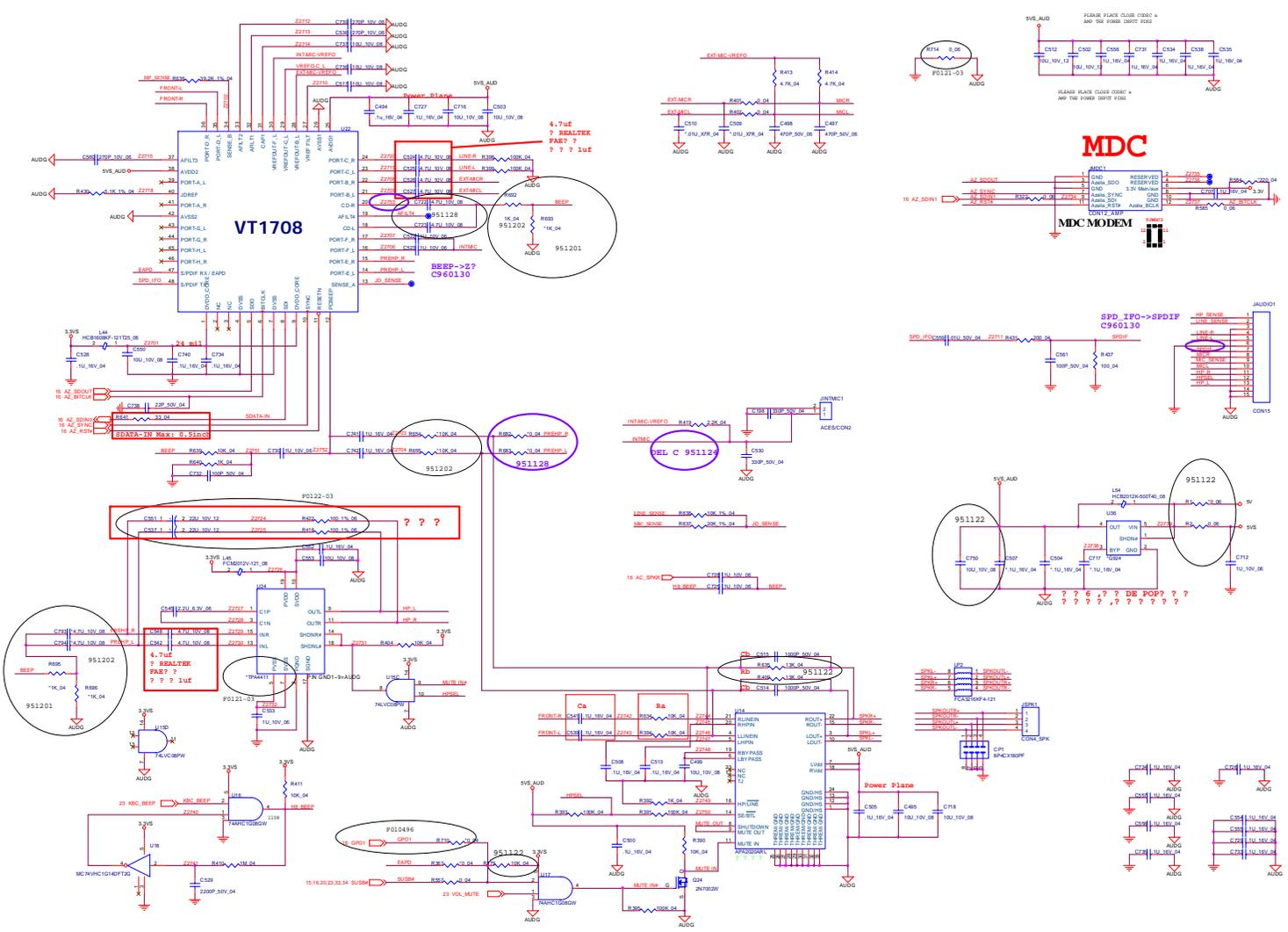

LED

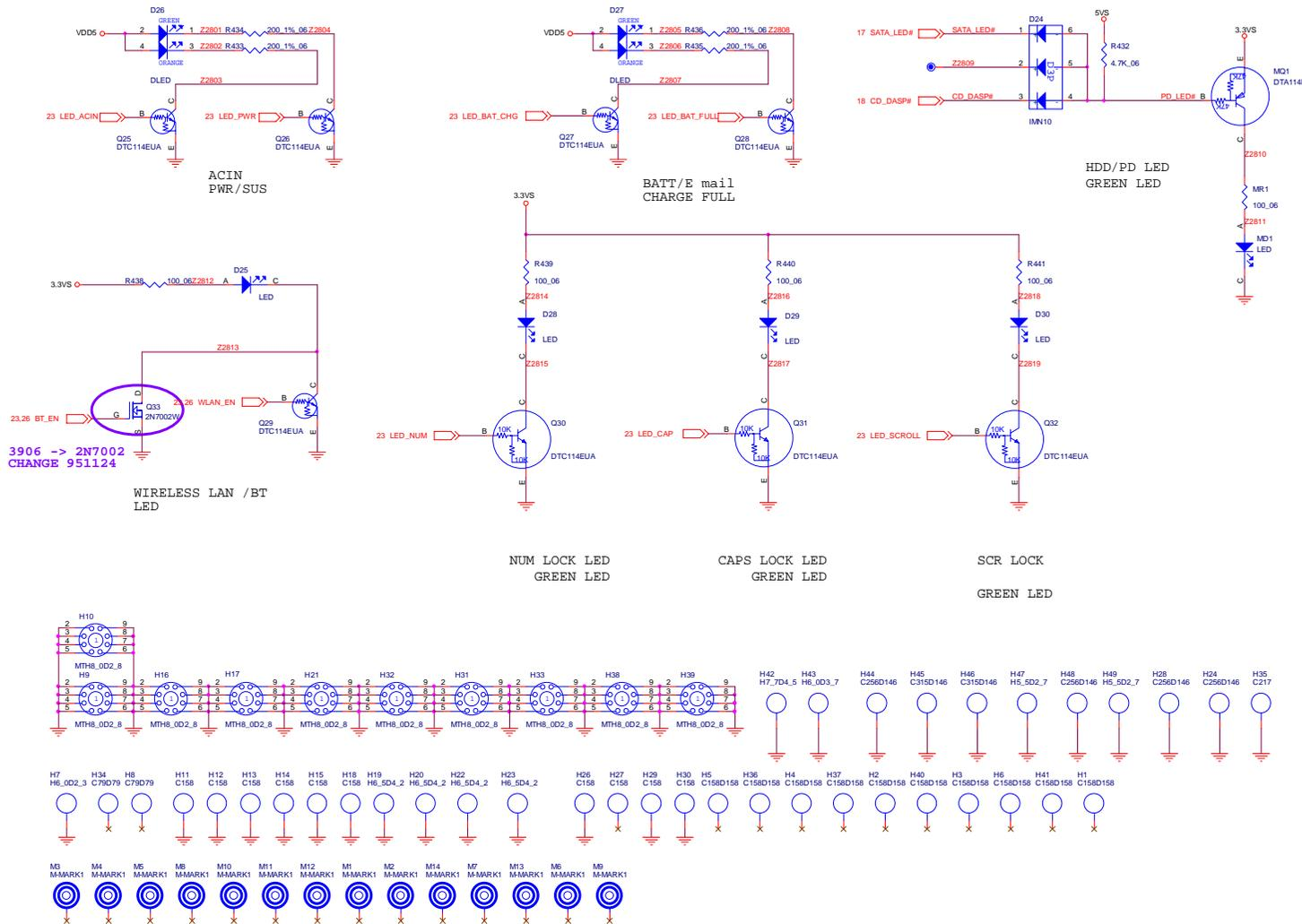

Sheet 28 of 40
LED

CHARGER, DC IN

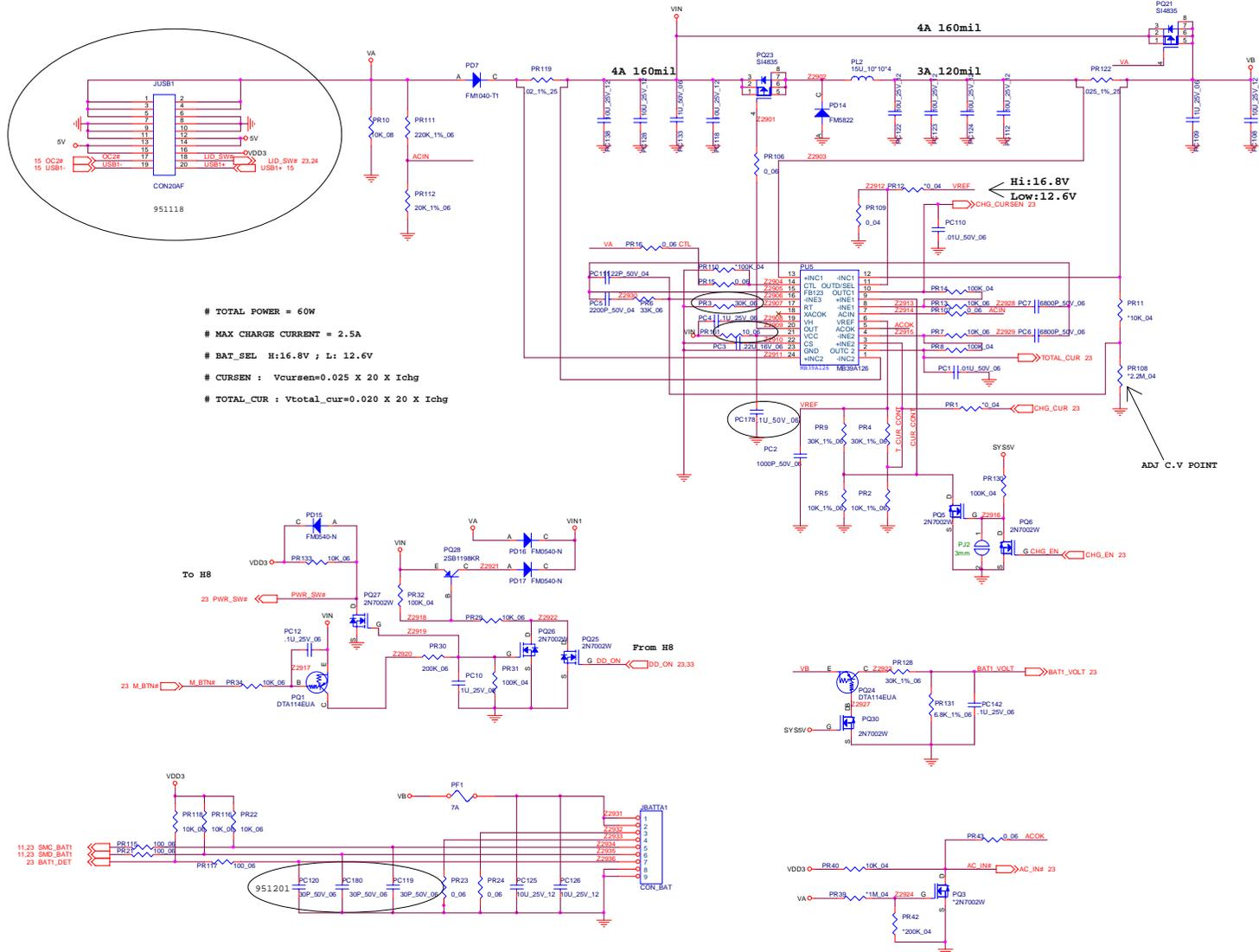

TOTAL POWER = 60W
 # MAX CHARGE CURRENT = 2.5A
 # BAT_SEL H:16.8V ; L: 12.6V
 # CURSEN : Vcursen=0.025 X 20 X Ichg
 # TOTAL_CUR : Vtotal_cur=0.020 X 20 X Ichg

Sheet 29 of 40
 CHARGER, DC IN

B.Schematic Diagrams

1.05VS, 1.5V, 2.5VS

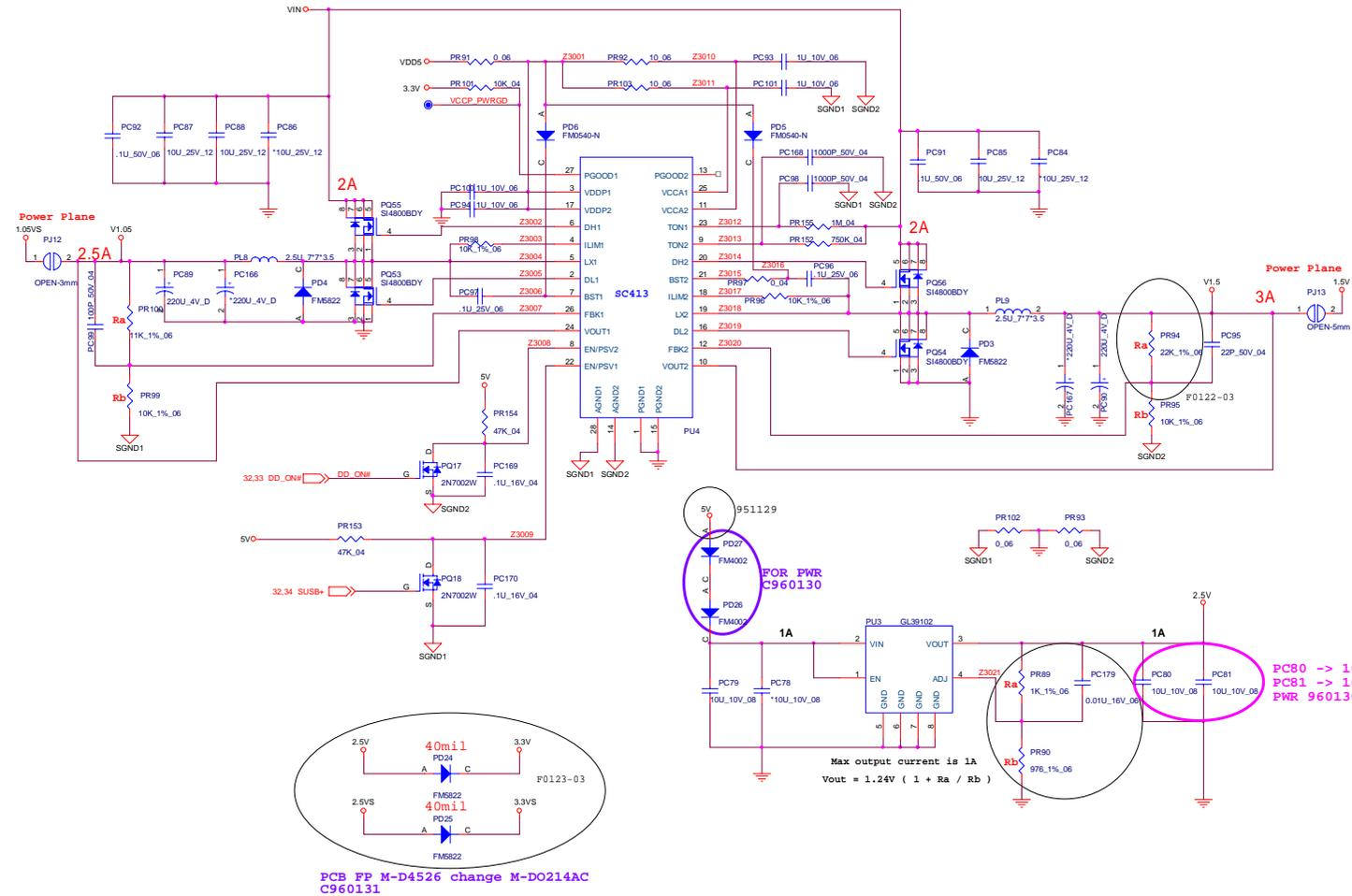

Sheet 30 of 40
 1.05VS, 1.5V, 2.5VX

B. Schematic Diagrams

1.8V, 0.9VS

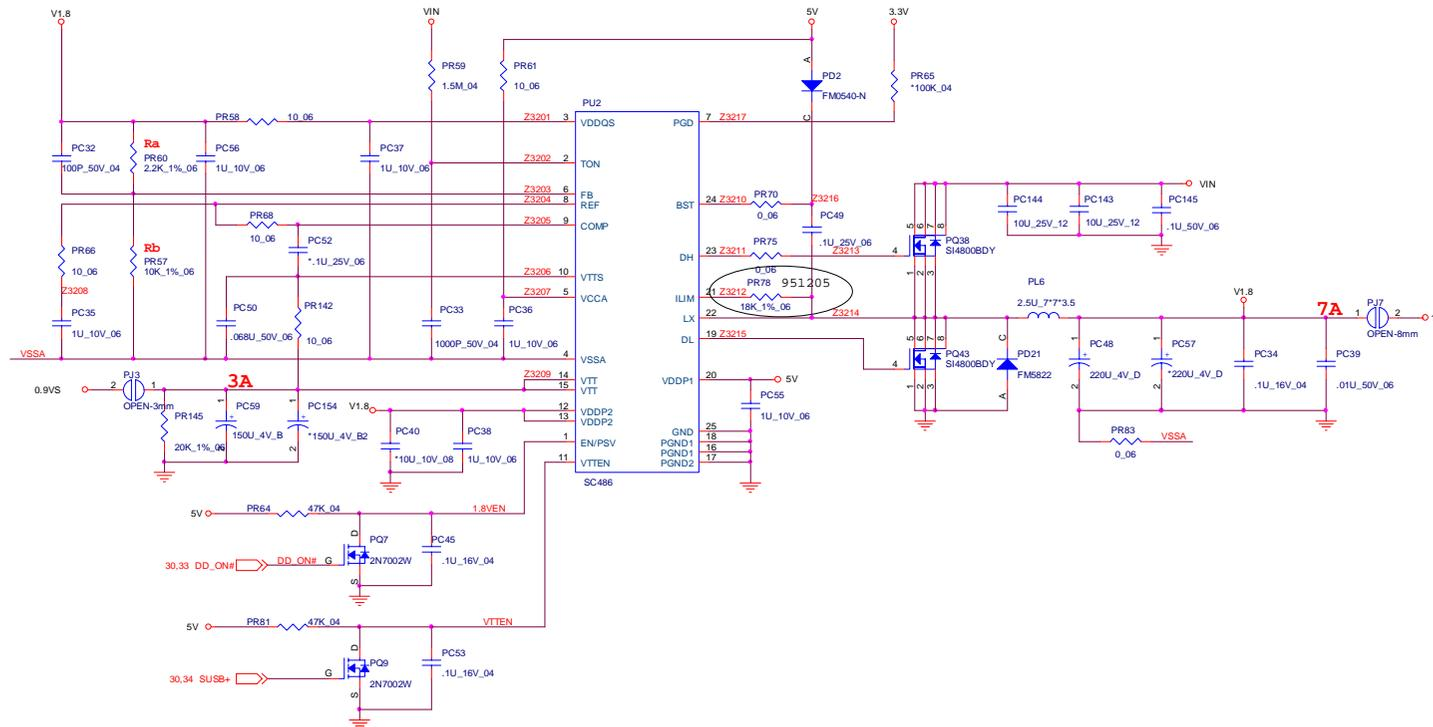

Sheet 32 of 40
1.8V, 0.9VS

EXT GPU 1.0VS/1.2VS

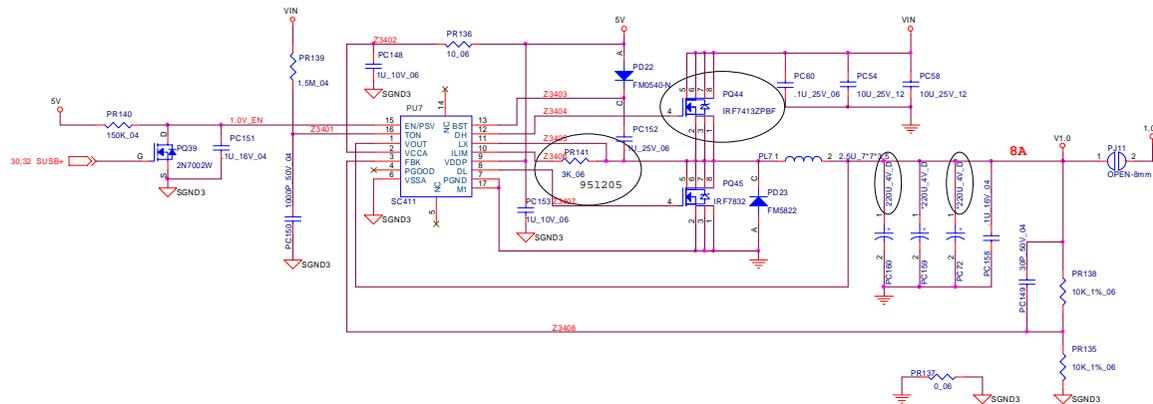

Sheet 34 of 40
EXT GPU 1.0VS/
1.2VS

B. Schematic Diagrams

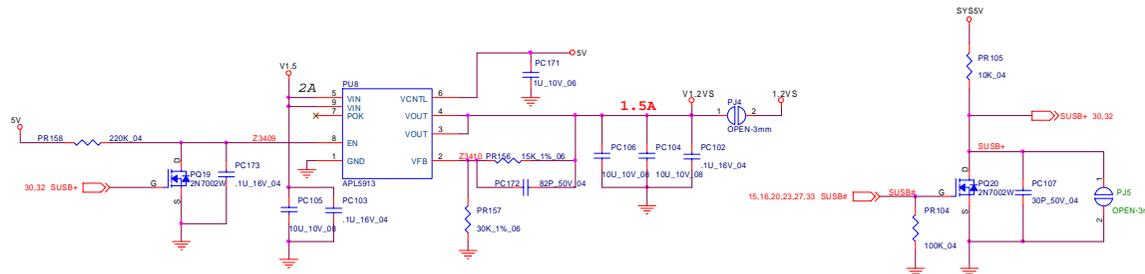

HOTKEY LT BOARD

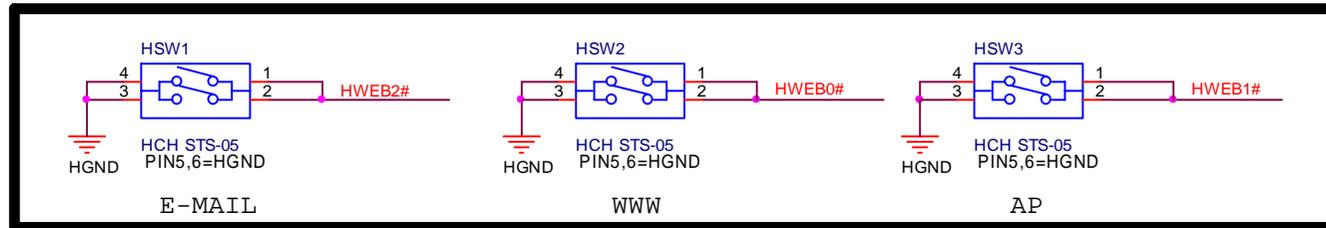

Sheet 35 of 40
HOTKEY LT
BOARD

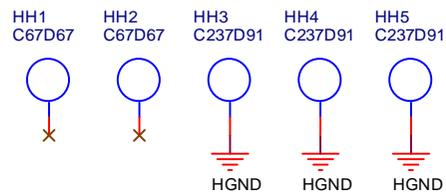
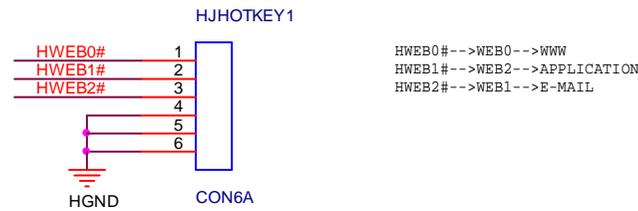

PWR HOT BOARD

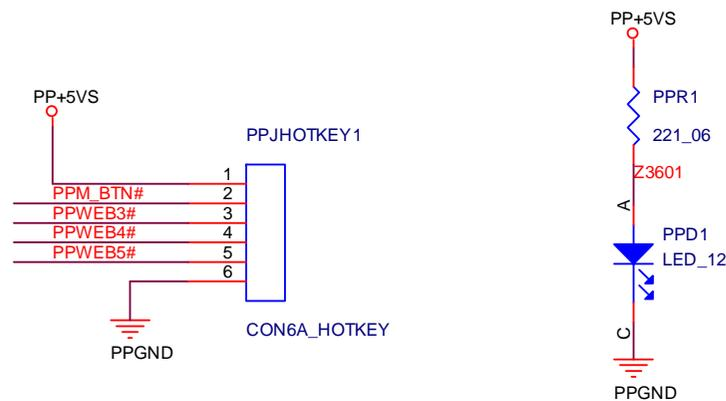
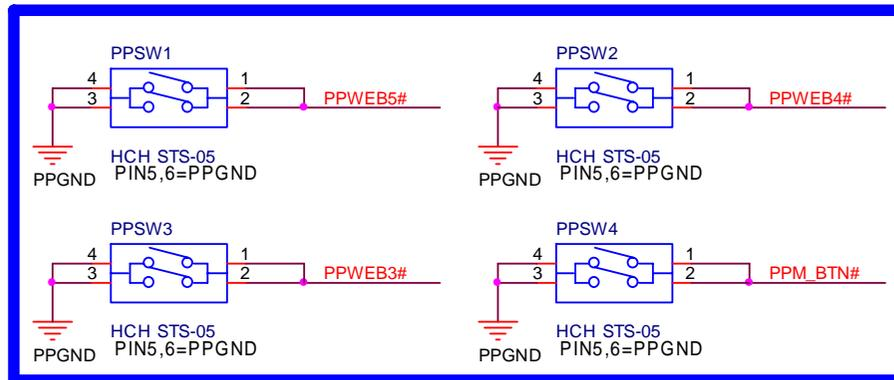

PWR LED

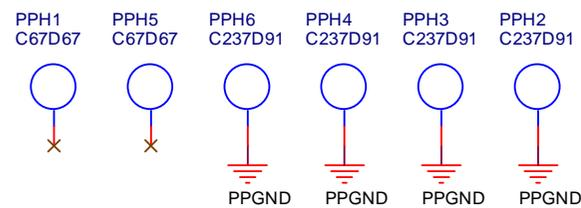

Sheet 36 of 40
PWR HOT BOARD

B.Schematic Diagrams

AUDIO & MODEM BOARD

Sheet 37 of 40
AUDIO & MODEM
BOARD

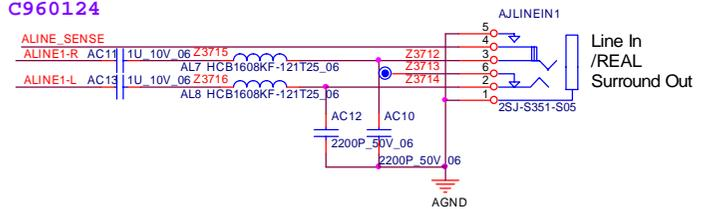
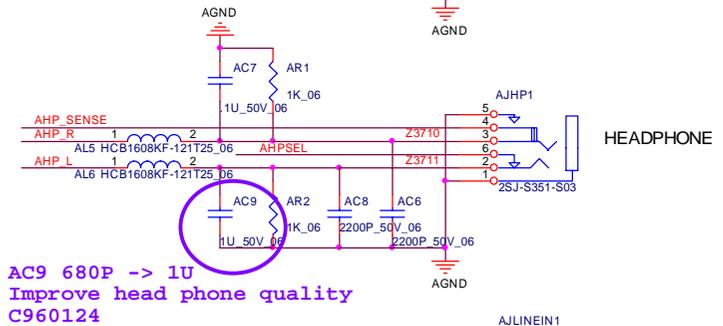
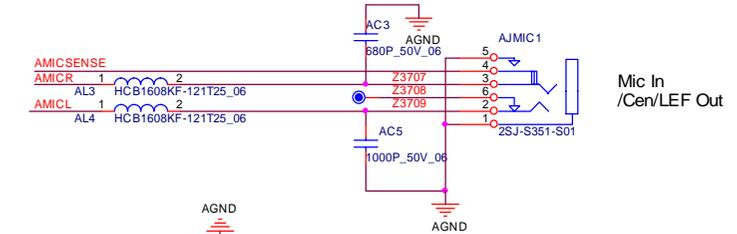
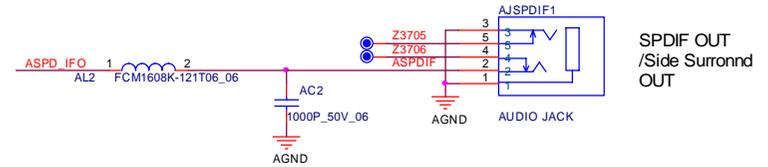
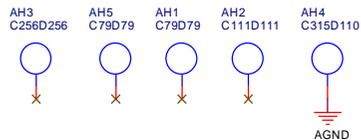
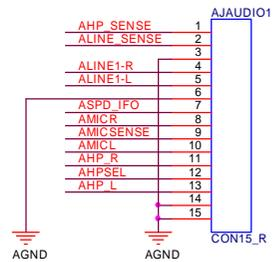
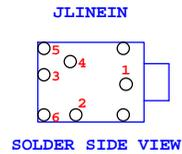
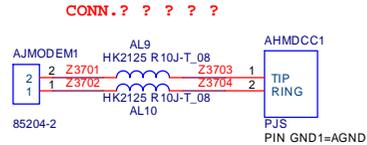

CLICK BOARD

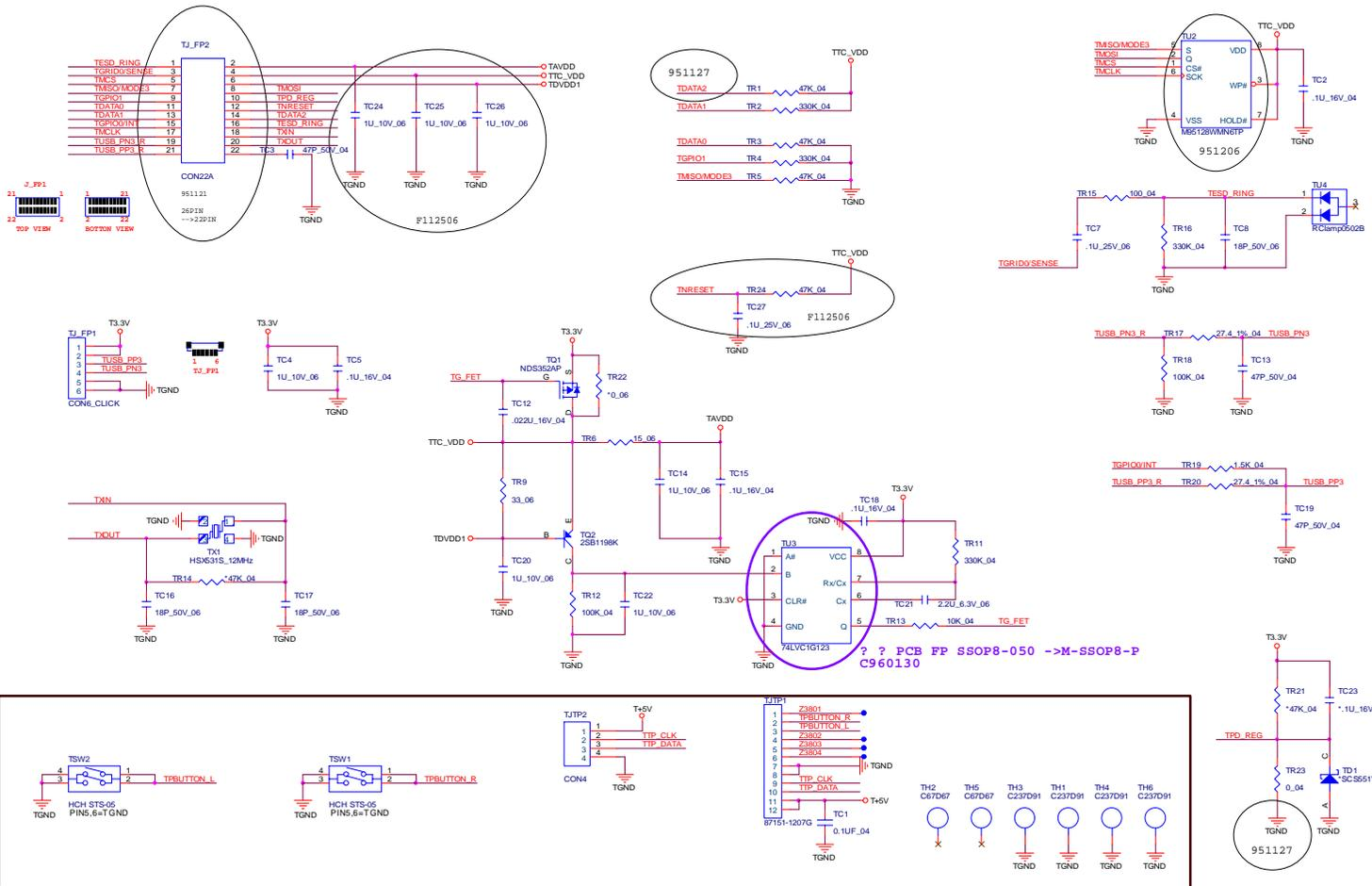

Sheet 38 of 40
CLICK BOARD

B. Schematic Diagrams

USB BOARD

Sheet 39 of 40
USB BOARD

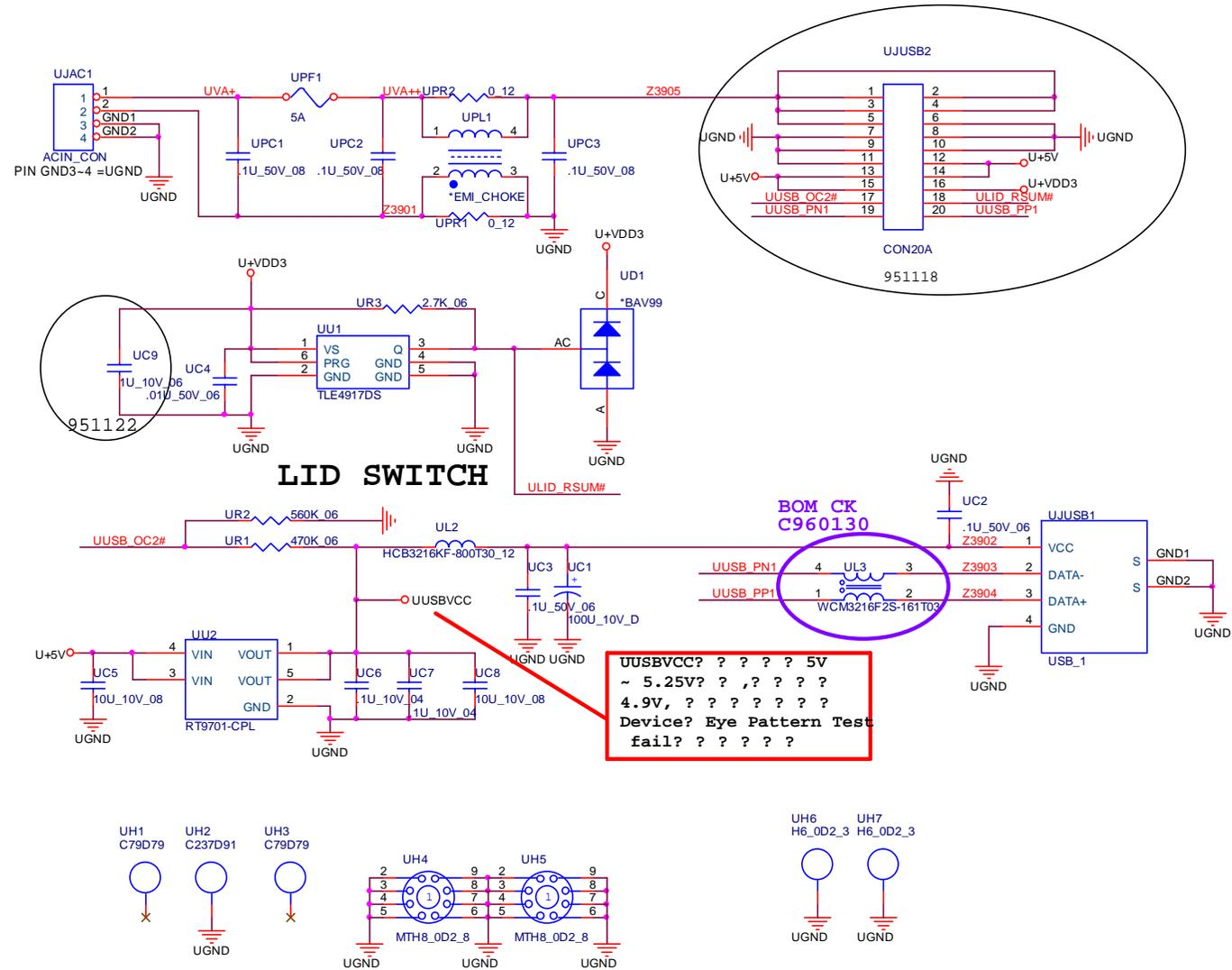

FINGERPRINT BOARD

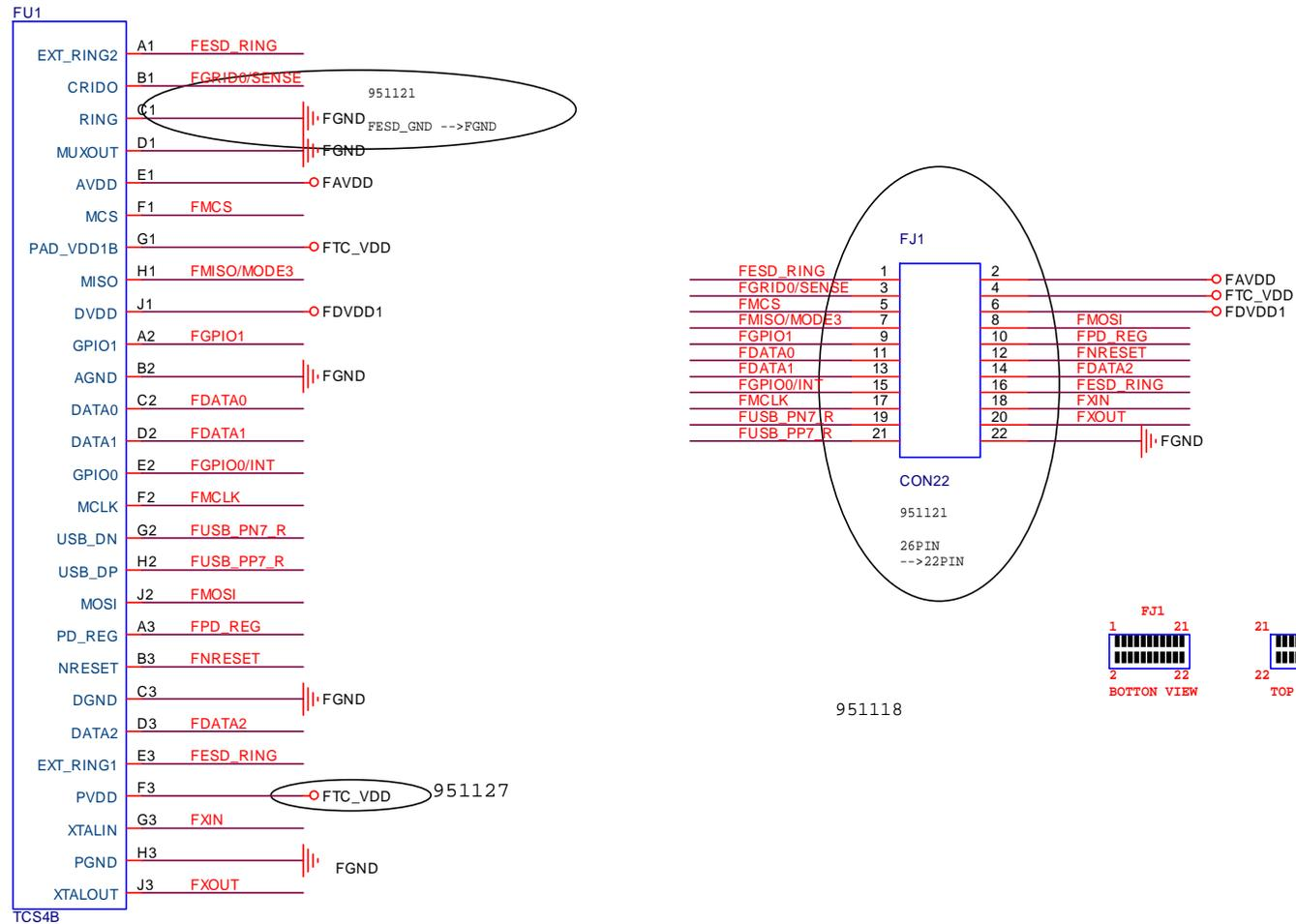

Sheet 40 of 40
FINGERPRINT
BOARD

Schematic Diagrams

Free Manuals Download Website

<http://myh66.com>

<http://usermanuals.us>

<http://www.somanuals.com>

<http://www.4manuals.cc>

<http://www.manual-lib.com>

<http://www.404manual.com>

<http://www.luxmanual.com>

<http://aubethermostatmanual.com>

Golf course search by state

<http://golfingnear.com>

Email search by domain

<http://emailbydomain.com>

Auto manuals search

<http://auto.somanuals.com>

TV manuals search

<http://tv.somanuals.com>