



1998 Operator's Manual

**4500
SERIES**

IMPORTANT: READ CAREFULLY

The Dixon® ZTR® Mower is both easy and fun to operate. However,
any power mower must be operated properly to be safe.
It is not a toy or a recreational vehicle.

Before you start to use the mower: read the operator's manual carefully, and
become completely familiar with the controls.

The information in this operator's manual applies to all
Dixon® ZTR® 4500 Series Model Mowers.

Your Dixon dealer will gladly provide a check-out ride,
and answer any questions.

See your dealer for warranty service, parts and repairs.



DIXON INDUSTRIES, INC.
A BLOUNT International Inc. Co.
PO BOX 1569
COFFEYVILLE KS 67337 0945
316251 2000

BLOUNT

INDEX

SAFETY	Pages 1 - 6
WARRANTY POLICY	Page
.....	7
SPECIFICATIONS	Page
.....	8
SEAT ADJUSTMENT	Page
.....	9
CONTROLS.....	Pages 10-13
OPERATION INSTRUCTIONS	Pages 14-19
CARE AND MAINTENANCE.....	Pages 20-30
STANDARD PARTS LIST.....	Page 31
TROUBLESHOOTING	Pages 32 - 34

4500 Series
Part No. 5863
mn1/98 MY98

SAFETY

*RIDING LAWNMOWERS, IF IMPROPERLY OPERATED,
CAN CAUSE SERIOUS INJURY OR DEATH*

The most common causes of injury to the operator or bystander..

BLADE CONTACT

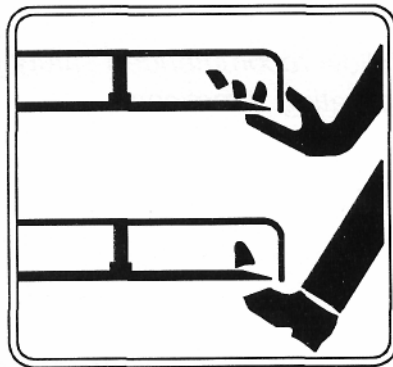

RUN-OVER



TIP-OVER

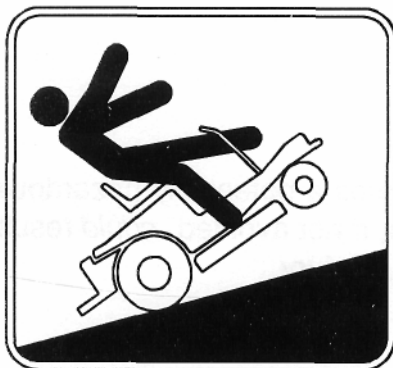

RUN-OVER

.read and understand this manual to prevent injuries.

SAFETY

SAFETY SYMBOLS:



SAFETY ALERT SYMBOL -

When you see this symbol,
BE ALERT to the potential for injury.

Follow recommended safety precautions and safe operating practices.



Danger indicates an imminently hazardous situation which, if not avoided, *will* result in death or serious injury.



Warning indicates a potentially hazardous situation which, if not avoided, *could* result in death or serious injury.



Caution indicates a potentially hazardous situation which, if not avoided, *may* result in minor or moderate injury. It may also be used to alert against unsafe practices.

SAFETY

This cutting mower is capable of amputating hands and feet, and throwing objects. Failure to observe the following safety instructions could result in serious injury or death.

GENERAL OPERATION:

- Read, understand, and follow all instructions in the manual and on the mower before starting.
- Only allow responsible adults, who are familiar with the instructions, to operate the mower.
- Clear the area of objects such as rocks, toys, wire, etc., which could be picked up and thrown by the blade.
- Be sure the area is clear of other people before mowing. Stop mower if anyone enters the area.
- Never carry passengers.
- Do not mow in reverse unless absolutely necessary. Always look down and behind before and while backing.
- Be aware of the mower discharge direction and do not point it at anyone. Do not operate the mower without either the entire grass catcher or the deflector in place.
- Slow down before turning.
- Never leave a running mower unattended. Always turn off blades, set parking brake, stop engine, and remove key before dismounting.
- Turn off blades when not mowing.
- Stop engine before removing grass catcher or unclogging chute.
- Mow only in daylight or good artificial light.
- Do not operate the mower while under the influence of alcohol or drugs.
- Watch for traffic when operating near or crossing roadways.
- Use extra care when loading or unloading the mower into a trailer or truck. Do not ride the mower when loading & unloading.

 **WARNING:** The Engine Exhaust from this product contains chemicals known to the State of California to cause cancer, birth defects or other reproductive harm.

 **SAFETY****SLOPE OPERATION:**

Slopes are a major factor related to loss-of-control and tip-over accidents, which can result in severe injury or death.

All slopes require extra caution. If you cannot back up the slope or if you feel uneasy on it, do not mow it.

DO

Mow across the slope with your Dixon ZTR - never up or down.

Remove obstacles such as rocks, tree limbs, etc.

Watch for holes, ruts or bumps. Uneven terrain could overturn the mower. Tall grass can hide obstacles.

Use slow speed.

Use extra care with grass catchers or other attachments. These can change the stability of the mower.

Keep all movement on the slopes slow and gradual. Do not make sudden changes in speed or direction.

Avoid starting or stopping on a slope. If tires lose traction, disengage the blades and proceed slowly down the slope.

DO NOT

Do not turn on slopes unless necessary, and then, turn slowly and gradually downhill, if possible.

Do not mow near drop-offs, ditches, or embankments. The mower could suddenly turn over if a wheel is over the edge of a cliff or ditch, or if an edge caves in.

Do not mow on wet grass. Reduced traction could cause sliding.

Do not try to stabilize the mower by putting your foot on the ground.

Do not use grass catcher on steep slopes.

 **SAFETY****CHILDREN:**

Tragic accidents can occur if the operator is not alert to the presence of children.

Children are attracted to lawn mowers and the mowing activity.

NEVER assume children will stay where they were last seen.

- Keep children out of the mowing area and under the watchful care of another responsible adult.
- Be alert and turn mower off if a child enters the area.
- Before and during backing, look behind and DOWN for small children.
- Never carry children. They may fall off and be seriously injured or interfere with safe mower operation.
- Never allow children to operate the mower.
- Use extra care when approaching blind corners, shrubs, trees, or other objects that may obscure vision.

 **SAFETY****SERVICE:**

- Use extra care in handling gasoline and other fuels. They are flammable and vapors are explosive.
 - Do not smoke.
 - Use only an approved container.
 - Never remove gas cap or add fuel with the engine running. Allow engine to cool before refueling.
 - Never refuel the mower indoors.
 - Never store the mower or fuel container inside a building where there is an open flame.
- Never run a mower inside a closed area.
- Keep nuts and bolts, especially blade attachment bolts, tight and keep equipment in good condition.
- Never tamper with safety devices. Check their proper operation regularly.
- Keep mower free of grass, leaves, or other debris buildup. Clean up oil or fuel spillage. Allow mower to cool before storing.
- Stop and inspect the equipment if you strike an object. Repair, if necessary, before restarting.
- Never make adjustments or repairs with the engine running.
- Grass catcher components are subject to wear, damage, and deterioration, which could expose moving parts or allow objects to be thrown. Frequently check components and replace with original equipment parts, when necessary.
- Mower blades are sharp and can cut. Wrap the blade(s) or wear gloves, and use extra caution when servicing them.
- Batteries contain sulfuric acid. To prevent burns avoid contact with skin, eyes and clothing. To prevent a fire or explosion keep sparks and open flames away from battery.

Before disconnecting the negative (-) ground cable, make sure all switches are OFF.

DIXON PROTECTION PLUS TWO YEAR LIMITED WARRANTY POLICY

This warranty policy applies to all ZTR 4500 Series mowers purchased on or after September 1, 1997.

WARRANTY: The Dixon Protection Plus Warranty term is for a period of two (2) years from date of purchase. DIXON ZTR MOWERS ARE WARRANTED AGAINST DEFECTS IN MATERIALS AND WORKMANSHIP AND PROVIDES FOR REPLACEMENT OR REPAIR OF PARTS INCLUDING LABOR COSTS. THIS WARRANTY IS SUBJECT TO THE FOLLOWING CONDITIONS AND LIMITATIONS:

1. Warranty applies only to original retail purchaser of new and unused mowers and accessories.
2. All Dixon warranty must be accomplished by authorized Dixon dealers and in accordance with Dixon warranty policy and allowances. All warranty claims must be approved by Dixon Industries, Inc.
3. Mowers or accessories used for commercial applications are warranted for 90 days from date of purchase. Commercial application is any use other than, or in addition to, mowing at owner's primary place of residence.
4. Battery warranty: Limited to 90 days from date of purchase.
5. Accessories Warranty (Grass Catchers, Snow Blades, Covers, etc.): Limited to 90 days from date of purchase.
6. Warranty does not apply to damage in transit or incidents of misuse, negligence, accidents, or alteration. The use of parts or components other than those supplied by Dixon Industries, Inc. VOIDS ALL WARRANTY.
7. The following items are not covered by this warranty policy:
 - (a) Pick up and delivery charges for transportation of mower to and from an Authorized Dixon Dealer's place of business.
 - (b) Routine maintenance or adjustments.
 - (c) Belts / chains / sprockets / cutting blades.
 - (d) Engines -- All engines used on Dixon ZTR mowers are warranted by each individual engine manufacturer.
 - (e) Any costs or expense of providing substitute equipment while repair work is being performed on a warranted mower.
8. There is no other express warranty. Implied warranties, including those of merchantability and fitness for a particular purpose, are limited to the same duration of the express warranty, and to the extent permitted by law any and all implied warranties are excluded. Liabilities for consequential damages under any and all warranties are excluded.

WARRANTY VALIDATION: At the time of sale, selling dealer must review each portion of this warranty document, complete the information section below, secure customer's signature and send copy to Dixon Industries, Inc.

DATE OF PURCHASE _____ Model _____ S/N DM- _____

(Owner's Name)

(Dealership)

(Address)

(Address)

(Owner's Signature)

(Dealer's Signature)

SPECIFICATIONS

Models ZTR 4515Band4515K

CHASSIS:	Twin 12 gauge side frames and 7 gauge transmission and engine base plate.
BODY:	All body parts are made of high density polyethylene. Dent and corrosion resistant. Front body contains access panel for battery service.
MOWER DECKS:	36" Deck: 1 1 GA Laser Cut Fabricated - 36" Cut Width 42" Deck: 13 GA Stamped Steel Construction - 42" Cut Width Cut height approximately 1 " to 4" via 7 position lift handle.
BLADE DRIVE:	Electric clutch.
TRANSMISSION:	Each rear wheel is independently driven by a HydroGear IZT hydrostatic drive.
ENGINE:	
Model 451 5B:	15 HP Vanguard Briggs & Stratton, 4-Cycle, Single Cylinder, Overhead Valve, Air-Cooled, Gasoline, Vertical Shaft With Cast Iron Cylinder Sleeve, Oil Pump With Integral Oil Filter.
Model 451 5K:	15 HP Kohler Command 15, 4-Cycle, Single Cylinder, Overhead Valve, Air-Cooled, Gasoline, Pressure Lubricated, With Oil Filter, Vertical Shaft, Aluminum Head and Block with Cast-Iron Cylinder Liner.
STARTING SYSTEM:	Electric by key switch operation with safety interlock blade drive.
TIRES:	Front 1 1 X 4.00 X 5 ribbed tread. Rear 1 8 X 8.50 X 8 Multi-Trac
RECOMMENDED TIRE PRESSURE:	Front 16-21 lbs. Rear 8-1 4 lbs.
CAPACITIES:	Fuel 2.7 gallons total. Engine Briggs & Stratton - 1 .50 quarts oil. Kohler - 2 quarts oil with filter.
DIMENSIONS:	Width 44" Maximum Track Width Height 42" to top edge of seat. Length 72" hitch tab to front bumper. Weight Power Unit: 463 lbs. w/36" Deck: 544 lbs. w/42" Deck: 541 lbs.
NOTE:	Additional information provided in service instructions under the individual component.

SPECIFICATIONS SUBJECT TO CHANGE WITHOUT NOTICE

SEAT ADJUSTMENT INSTRUCTIONS

Models ZTR 4515B & ZTR 4515K

1. Place parking brake in ON position. (Pull brake lever up)
2. Raise and push seat assembly forward.
3. Loosen five nuts, P/N 3205, and slide seat forward or backward to desired position. Re-tighten nuts, P/N 3205.

***DO NOT* operate mower without seat adjustments properly tightened.**

4. Raise and push seat assembly and upper body rearward to closed position.

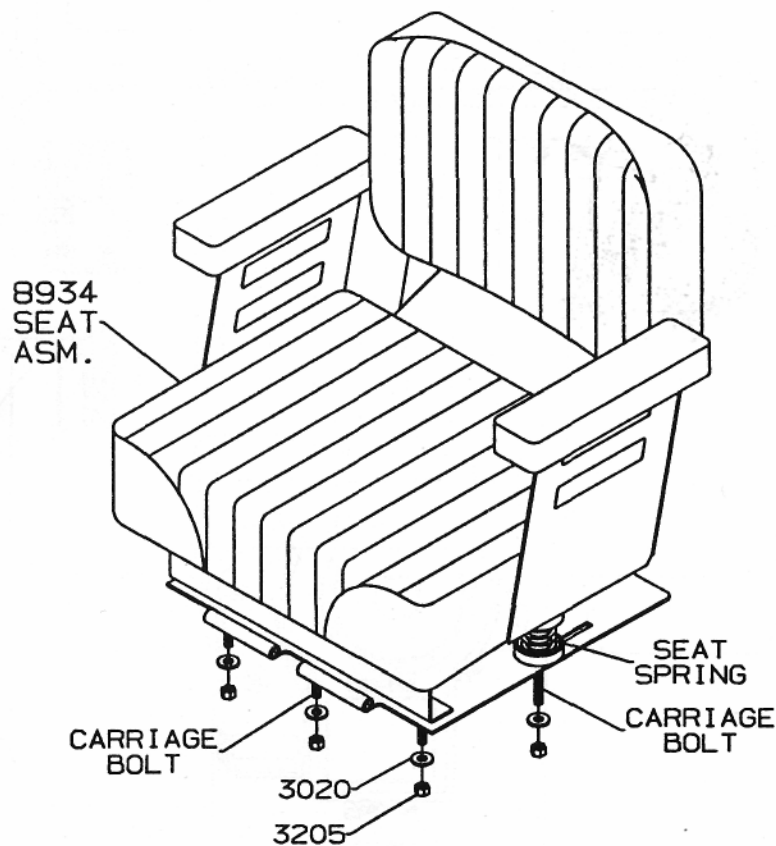

CONTROLS

Models ZTR 4515B and 4515K

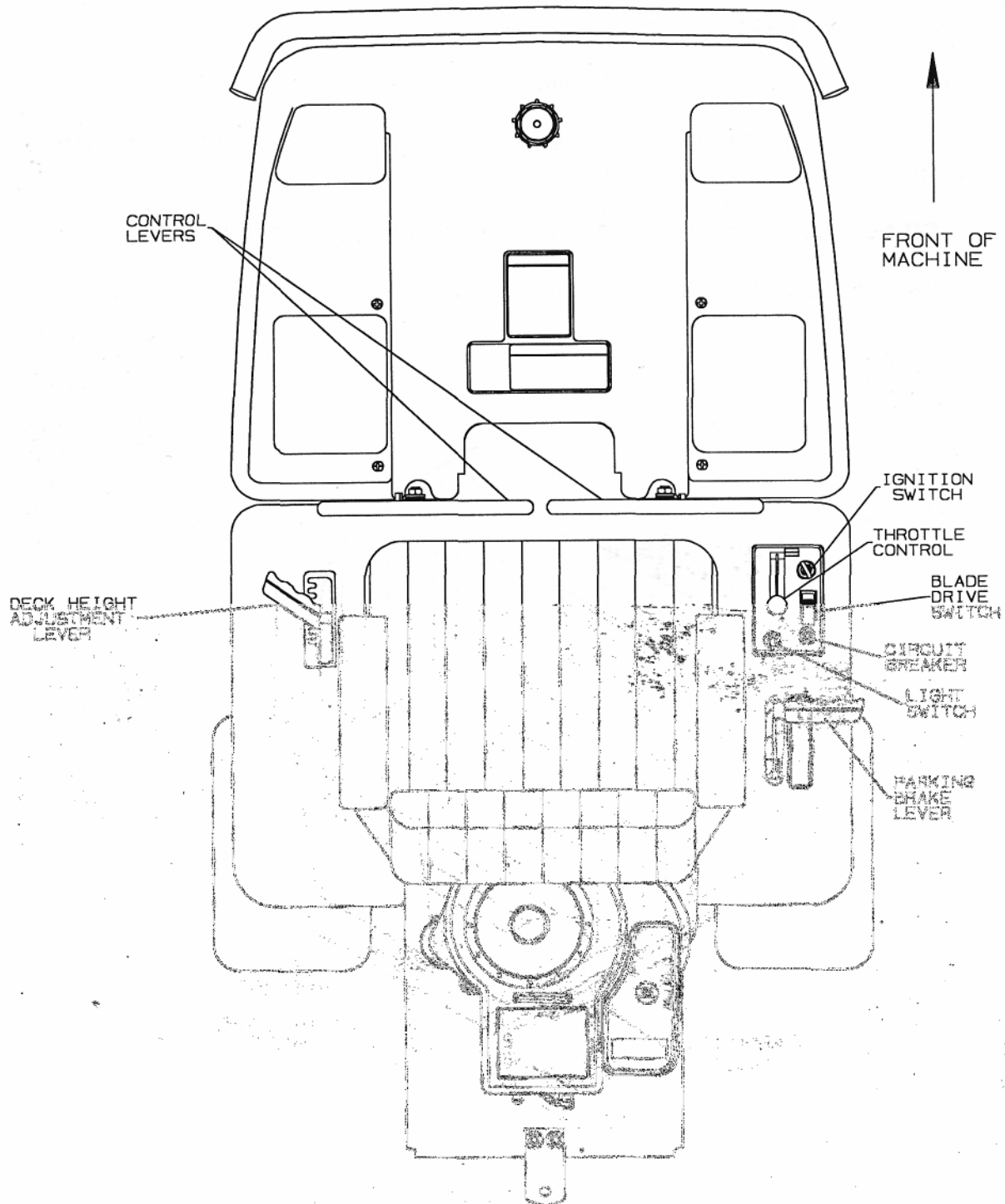

CONTROLS

All controls are described from operators position:

PARKING BRAKE:

The parking brake used on the ZTR 4500 Series Models is designed to hold the mower from moving and is *not* intended for use in stopping the mower while it is in motion. The engine will stop if the parking brake is engaged while the control levers are in the drive position.

TO SET PARKING BRAKE:

The parking brake is located on the right fender of Models ZTR 4515B and ZTR 4515K.

To engage brake, pull lever up and to the rear. To release brake, move lever forward and down.

NOTE: Always set parking brake before dismounting.
Release parking brake before moving mower.

TRANSMISSION DRIVE SYSTEM:

Allows the mower to turn on its own axis "Zero Turning Radius". Each lever controls one side of the mower.

NOTE: The pressure required to operate the mower is very light.

A minimum of 1/2 hour should be spent simply driving the mower without the blade drive engaged.

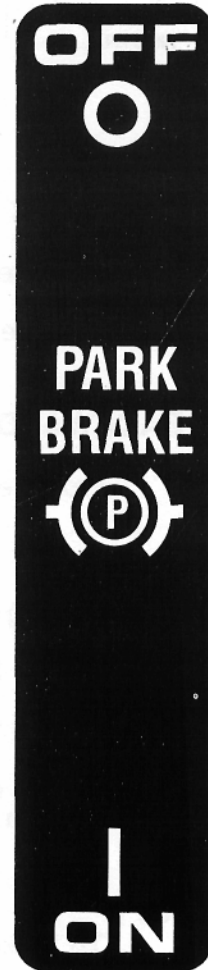

CONTROLS:

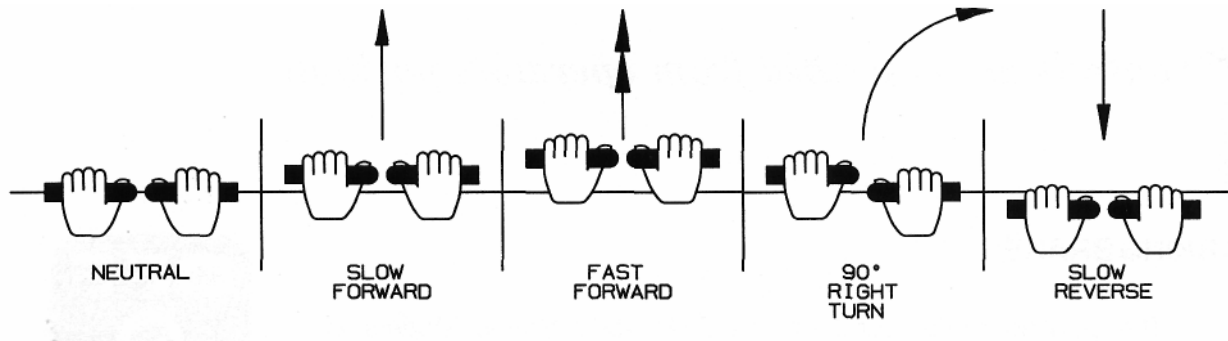

TO GO FORWARD:

From neutral position, gently push both drive levers forward.

To increase speed, move levers farther forward.

TO GO BACKWARD:

From neutral position, gently pull both drive levers toward you.

TURNING:

Turning is controlled by moving one drive lever slightly forward or rearward of the other.

To turn left, move left lever rearward of the right lever.

To turn "square corners" move lever of desired direction to neutral.

To turn on mower's own axis (zero turning radius) stop and move one lever to reverse position and the other to forward position.

BRAKING:

To brake mower, move both levers in direction opposite of travel, release levers to neutral, set parking brake. Park only on level surfaces.

TWIN FUNCTION THROTTLE CONTROL:

Located on control panel to operator's right.

Throttle control for engine speed.

Choking for engine starting.

Throttle Control should be set to the MAXIMUM or wide open setting to insure adequate cooling of the engine and to maintain mower deck blade speed while mowing.

CONTROLS:

BLADE DRIVE:

Located on control panel, on operator's right.

To engage the mower blades, move switch to the rear and lift.

To disengage blades, move switch backward. Switch is clearly marked "on and off".

CIRCUIT BREAKER:

Protection of the electrical system is by (1)15 amp circuit breaker.

If circuit breaker trips, push button to reset.

If this condition repeats, consult dealer for inspection and repair.

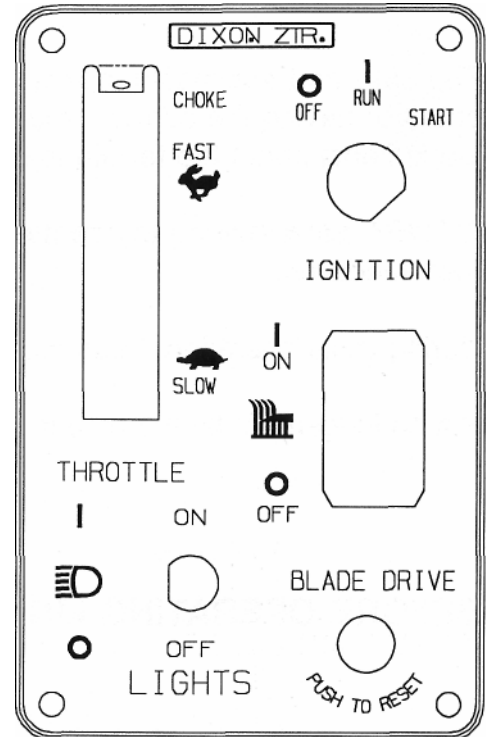

MOWER DECK CUT HEIGHT LIFT LEVER:

Located to the left of operator.

Controls the cutting height. Seven positions of adjustment. Move lever in and forward to lower. Move lever in and back to raise. NOTE: Always use high for transport.



OPERATION INSTRUCTIONS

The safe and successful operation of the ZTR 4500 Series Models will depend upon the operator having the correct knowledge of all controls used on the mower and making good judgements about the terrain to be mowed.

NEVER allow anyone to operate the mower without complete knowledge of all controls and their functions.

During initial operation, "learning to drive", set throttle at slow speed.

Sound judgement by the owner will prevent accidents.

BEFORE OPERATING MOWER:

1. Read engine manufacturer's operating and maintenance instructions.
2. Read and observe all safety instructions on your mower and in the manual.
3. Check engine oil.
4. Check gas cap to be sure it is in place.
5. Be sure parking brake is on.
6. Be sure mower blade drive is off.
7. Know how to stop engine. (Turn key to off position)

OPERATION INSTRUCTIONS



TESTING OF SAFETY INTERLOCK SYSTEMS:

- PARKING BRAKE SWITCH TEST:**
- Swing out control levers
 - Disengage blade drive switch
 - Put Parking brake in OFF position
 - Turn ignition switch to START
- Engine should not turn over or attempt to*
- CONTROL LEVER SWITCH TEST:**
- ^{start} Disengage blade drive switch
 - Put parking brake in ON position
 - Swing control levers in
 - Turn ignition switch to START
- Engine should not turn over or attempt to*
- BLADE DRIVE SWITCH TEST:**
- Put parking brake in ON position
 - Swing out control levers
 - Engage blade drive switch
 - Turn ignition switch to START
- Engine should not turn over or attempt to*
- SEAT SWITCH TEST:**
- In a SAFE AREA away from bystanders, start the engine
 - Leave levers swung out and parking brake ON
 - Engage blade drive
 - Raise weight slightly off seat
- ENGINE SHOULD STOP*
- Disengage blade drive
 - with engine running, put parking brake in OFF position
 - Swing levers in
 - Engage blade drive
 - Raise weight slightly off seat.
- ENGINE SHOULD STOP*

NOTE: *If Any Safety Check FAILS, Do Not Operate The Mower until the system has been checked and repaired by an Authorized Dixon ZTR Dealer*

OPERATION INSTRUCTIONS

The Dixon ZTR requires only two drive levers to control braking, turning, speed, and direction.

On initial operation, set throttle speed on slow & operate with mower blade "OFF".

To avoid "over-controlling" the mower, use a light touch on the drive levers. Slight movements using *finger tip* control is all that is necessary.

⚠ CAUTION Engage parking brake before starting engine.

STARTING INSTRUCTIONS:

1. Parking brake must be on, control levers swung out, and blade drive disengaged.
2. Move throttle control to "Choke" position if engine is cold, full throttle if warm.
3. Insert ignition key and turn to "Start" position. When engine starts, release ignition key. Key will return to "Run" position.
4. Move throttle from "Choke" to desired speed position.
5. Release parking brake.
6. Swing levers in.

NOTE: While mowing throttle control should be set to the **MAXIMUM** or wide open setting to insure adequate cooling of the engine and to maintain mower deck blade speed.

Engine cannot be restarted when blade drive is engaged, the parking brake is off, or levers are swung in.

Safety switches stop engine when operator leaves seat while mower blade is engaged.

Always turn engine off when leaving mower. **DO NOT** rely on safety switches.

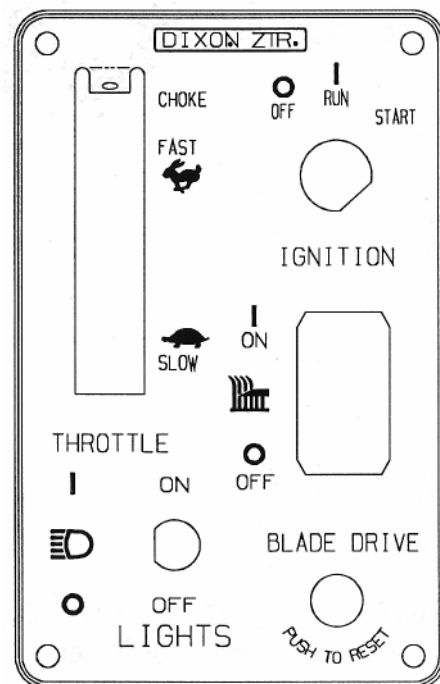

OPERATION INSTRUCTIONS

MOWING WITH A MULCHING ATTACHMENT:

Mulching or recycling the grass clippings requires a totally different mowing approach than would be normal when side discharging or bagging the grass. There may be instances or conditions where it is not possible to hide all of the recycled or mulched clippings.

In order to achieve the best results, please read and follow the mulching tips listed below:

1. Set the engine speed control to the wide open or full setting.
2. Place the mower deck cut height selector in either the top or second notch. Never cut more than 3/4" to 1" off the grass at any one time. Attempting to cut more grass will result in the deck plugging and cause the engine to stall.
3. It may be necessary to cut the lawn twice to achieve acceptable mulching performance especially on first cuttings or if the lawn is heavily fertilized.
4. *Do Not Attempt To Cut Grass When It Is Wet.* Mulching performance will be very poor under wet grass conditions.
5. *Maintain A Sharp Blade Throughout The Cutting Season.* This is very important. Optimal mulching performance cannot be obtained with a dull or nicked up blade.
6. *Keep The Underside Of The Mower Deck Clean.* Remove all grass and dirt buildup from the underside of the pan, the baffles and deflectors after each use.
7. Alternate mower direction. This will evenly disperse the mulched grass clippings over the lawn for even fertilization.

If the mulching quality of the mower does not seem to be satisfactory, try one or more of the following tips:

1. Raise the height-of-cut setting on your mower.
2. It may be necessary to cut your grass more frequently.
3. Operate the mower at a slower ground speed.
4. Overlap cutting swaths instead of cutting a full swath with each pass.
5. Mow across the marginal areas a second time.
6. CUT HIGH - MOW OFTEN!

OPERATION INSTRUCTIONS

MOWING WITH A GRASS CATCHER ATTACHMENT:

In order to achieve optimum performance when mowing with a grass catching attachment, please read and follow the tips listed below.

1. Some applications may require installation of an "Optional" weight box on the front of the mower to offset cut grass weight.
2. Set engine speed control to the wide open or full setting.
3. *Do Not Attempt To Cut Grass When It Is Wet.* Wet grass will clog both the underside of the deck and the attachment chutes. Empty bags often to prevent plugging.
4. If the grass is tall, place the mower deck cut height selector in the top or second notch. Initially overlap cutting swaths instead of a full swath with each pass.
5. *Keep The Underside Of The Mower Deck Clean.* Frequent removal of dried grass and dirt will greatly assist in bagging of the clippings.
6. *Maintain Sharp Blades Throughout The Cutting Season.* Some grass catching attachments require "Hi-Lift" blades.
7. Operate the mower at a slower ground speed than when mowing without a grass catching attachment.

CAUTION

- Watch for low hanging branches or other obstacles which might hit the catcher top while turning or backing the mower.
- Use care when backing to avoid pushing the grass bags into the frame or "hot" exhaust muffler of the engine.
- Disengage blade and stop engine prior to clearing grass from either the discharge chute or grass catcher components.
- Keep all attachment bolts tight.
- *Do Not* operate the mower with the grass catching attachment partially removed.

Important:

- Do not leave clippings in the bags while the mower is stored.
- Damp grass clippings are a fire hazard if left in the bags.

OPERATION INSTRUCTIONS

SIDE DISCHARGE OF THE CLIPPINGS:

In order to achieve optimum performance when side discharging the grass clippings, please read and follow the tips listed below.

Additional information can be found in the troubleshooting guide.

 **CAUTION** Be sure that deflector is properly installed on the discharge chute.

1. Set engine speed control to the wide open or full setting.
2. *Do Not Attempt To Cut Grass When It Is Wet.* Wet grass will clog the underside of the deck and discharge area.
3. If the grass is tall, place the mower deck cut height lever in the top or second notch. Initially overlap cutting swaths instead of a full swath with each pass. Some applications may require a second cutting.
4. *Keep The Underside Of The Mower Deck Clean.* Frequent removal of dried grass and dirt will allow the clippings to discharge correctly.
5. *Maintain Sharp Blades Throughout The Cutting Season.*

GRASS HEIGHT SUGGESTIONS:

Correct mowing height can reduce weeds and disease by 50 to 80%

The following grass cut heights are based on adequate moisture conditions and normal thatch buildup in a healthy lawn. Some locations and applications may require slightly different cut heights. If in doubt, consult your local lawn professional for assistance.

Grass Types:	Best Cut Heights
Zoysia	2" - 2 1/2"
Blue Grass	1 1/2" - 3"
Fescue Blends	1 1/2" - 3"
St. Augustine (Mid South)	1 1/2" - 2"
St. Augustine (Deep South)	3" - 4"
Tifton Bermuda	1 1/2"
Centipede	1 1/2" - 2"
Common Bermuda	1 1/2" - 2"
Bahia/Argentina/Pensacola	2"

CARE AND MAINTENANCE

This portion of the ZTR 4500 Series Models owners manual deals with normal service items which can be performed by the owner. Please remember that if you are in doubt as to the correct service procedures to be followed, these and other service situations can be handled by a Dixon ZTR dealer who is familiar with the service of your mower.

MAINTENANCE SCHEDULE:

To insure a long and trouble free service life on all the components used on the ZTR 4500 Series Models, a regular and thorough maintenance schedule should be followed. The following items should be checked after the first (10) hours of operation and on a weekly basis, or each (40) hours of use:

1. Drive system, belts and controls.
2. Mower deck belts.
3. Tire pressures.
4. Tightness of all nuts and bolts.
5. Battery fluid level.
6. Engine Oil.

 **CAUTION** Before performing any maintenance, shut off engine, allow to cool.

ENGINE: For engine operating and maintenance information, refer to the engine operating and maintenance instructions furnished by the engine manufacturer, supplied with each mower.

BATTERY: Check the fluid in the battery at frequent intervals.
Keep fluid level above the plates in each cell, using distilled water.

OFF-SEASON BATTERY STORAGE:

Identify each cable so cables can be reconnected to correct terminals.

Disconnect cables from terminals

ALWAYS disconnect ground cable first and reconnect last

Charge battery.

DO NOT remove battery from mower.

Clean top of battery and terminals with baking soda and water.

CARE AND MAINTENANCE

MOWER BLADE MAINTENANCE:

NOTE: Observe proper blade position prior to removal.

1. Safely raise front of mower.
2. Hold or block blade from turning.
3. Loosen blade nut and remove blade.

⚠ CAUTION Wear heavy, thick gloves when holding onto mower blade, avoid the sharp edge of the blade.

4. Tighten blade nut securely. Refer to diagram.

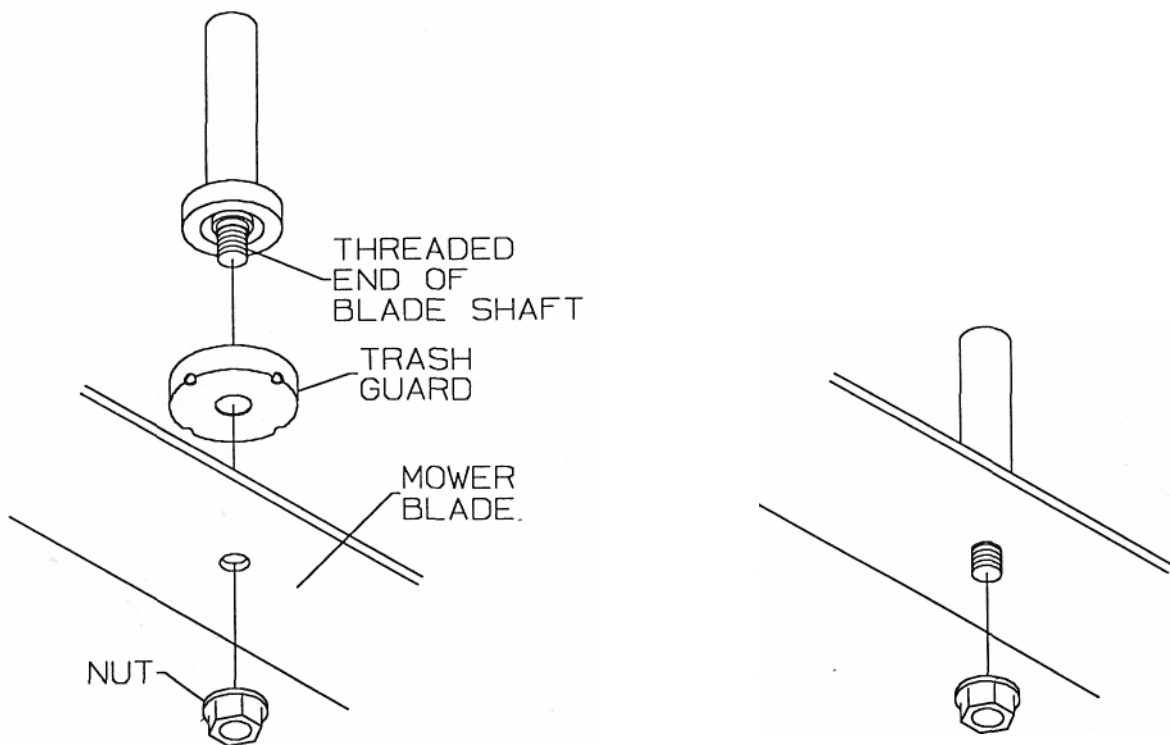

CARE AND MAINTENANCE

BELT TENSION:

42" DECK: ENGINE TO MOWER DECK BELT: P/N 5861

No adjustment required.

Correct belt tension is maintained through a fixed engine location and a spring loaded idler system.

A pulsing movement of the belt idler will be observed both during engagement of the electric blade clutch and actual operation of the mower deck.

NOTE: Engagement of the electric blade clutch switch may - 'H'sce a sharp high pitched chirp or squeal as the belt tension loading ir . v rbed by the idler system. This is normal and not a sign of failure.

36" DECK: MOWER DECK DRIVE BELT: P/N 1300

42" DECK: MOWER DECK SERPENTINE BELT: P/N 6109

Adjustment procedure illustration below for 36" Mower Deck Drive Beit P/N 1300, and 42" Mower deck Serpentine Belt P/N 6109:

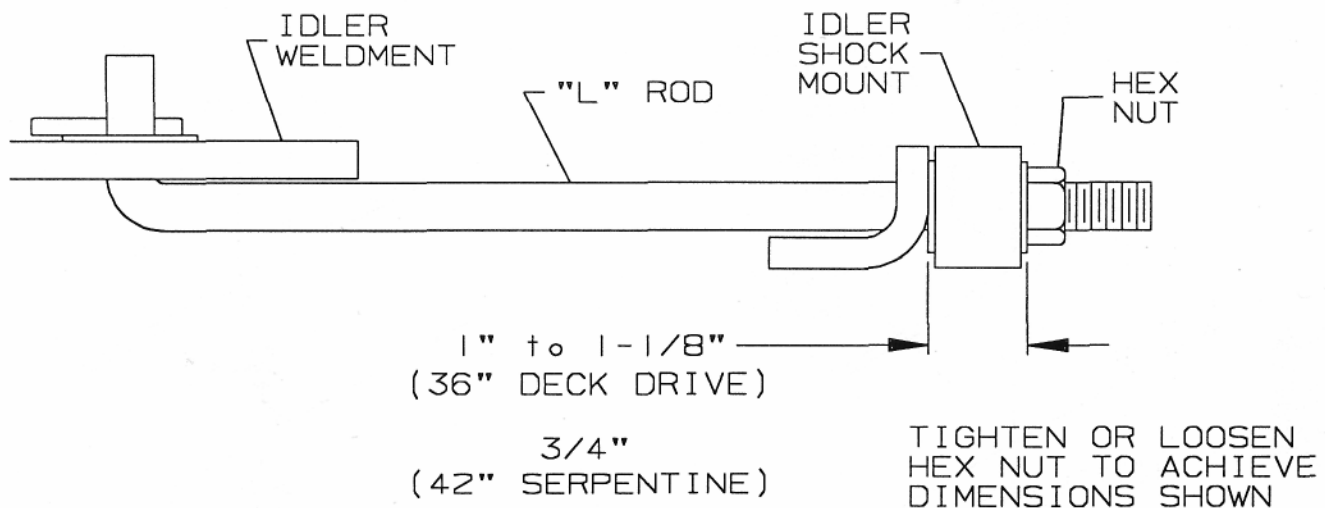

CARE AND MAINTENANCE

FORWARD TRAVEL SPEED ADJUSTMENT

1. Drive machine until hydrostats have warmed up.
2. Drive on a smooth, level surface with both levers in top speed position.
3. If one side now drives slightly faster than the other, adjust lever stop washer P/N 5760 on that side to reduce forward range of control lever. If levers are now uneven at top speed, loosen control lever mounting nut. Rotate lever to be even with other side and tighten nut.

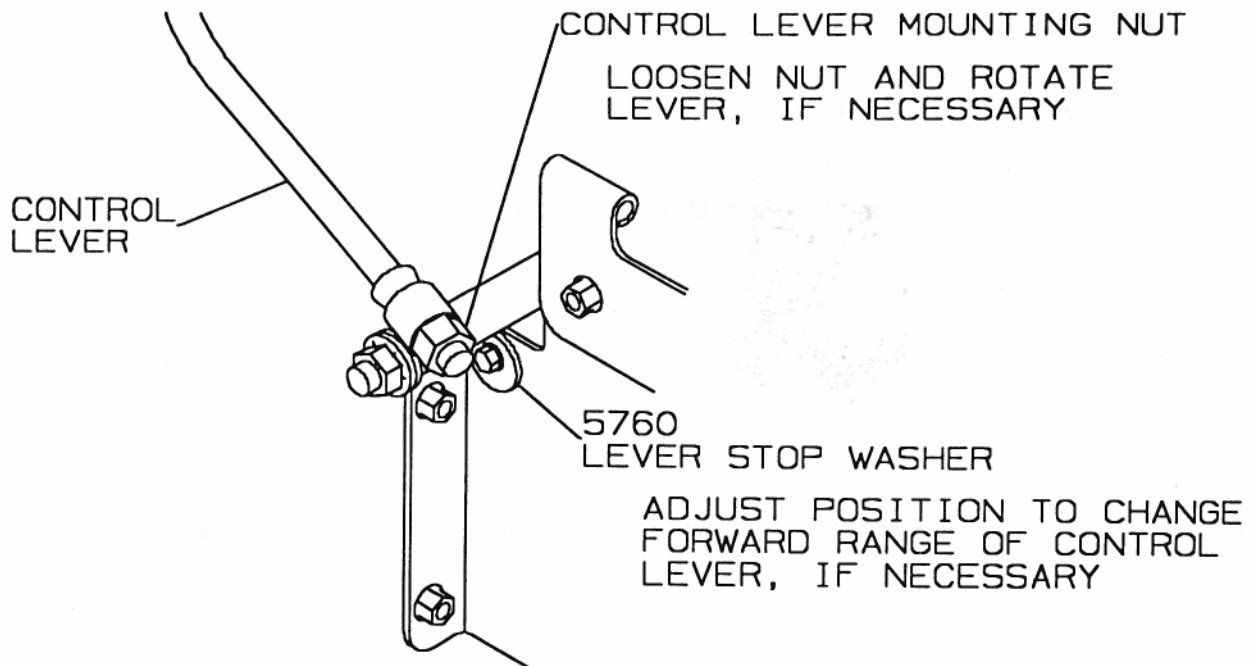

CARE AND MAINTENANCE

NEUTRAL ADJUSTMENT

DRIVE MACHINE UNTIL HYDROSTATS HAVE WARMED UP. WITH ENGINE RUNNING AND THE PARKING BRAKE OFF, SWING OUT THE CONTROL LEVERS. IF MACHINE STARTS TO CREEP, FOLLOW THE INSTRUCTIONS BELOW.

1. Stop the engine, engage parking brake, and raise rear of frame with jack or blocks so that rear tires do not contact the ground.
2. Swing out the control levers, start the engine and release the parking brake.
3. Raise the seat to access hydro control linkage. If right wheel creeps, adjust right side linkage, and vice-versa. Use procedure below:

a. Loosen, but do not remove, the bolt in the control tube P/N 5540.

b. Loosen Jam nuts on ends of the coupler P/N 7736.

c. If right wheel is creeping forward, turn coupler counter clockwise until neutral is achieved (clockwise for left side). If right wheel is creeping backward, turn coupler clockwise until neutral is achieved (counterclockwise for left side).

d. Tighten jam nuts against coupler.

e. Tighten bolt in control tube.

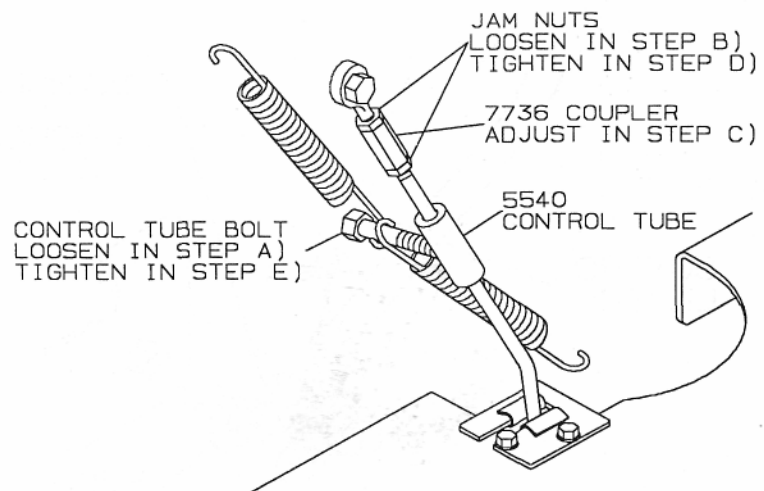

4. Lower seat, release parking brake, and swing control levers in. If wheel creeps, repeat steps 3a & 3e.

5. Stop engine and remove rear of machine from jack or blocks.

6. Drive machine with both levers in top speed position. If one side now drives slightly faster than the other, adjust lever stop washer P/N 5760 on that side to reduce forward range of control lever. If levers are now uneven at top speed, loosen control lever mounting nut. Rotate lever to be even with other side and tighten nut.

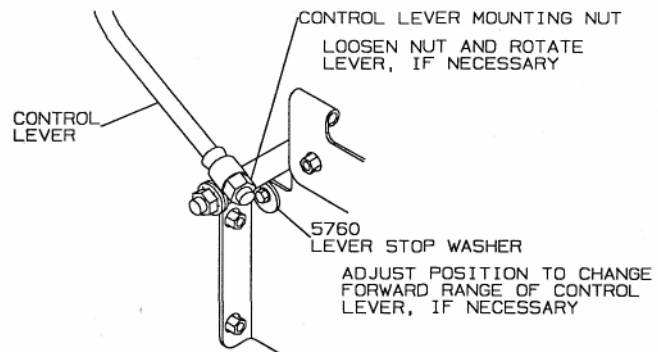

CARE AND MAINTENANCE

MOWER DECK LEVELING PROCEDURE:

1. Place mower on a smooth, level surface and check tire pressures to insure correct stance. Tires should be inflated as follows:

Front: 16-21 lbs

Rear: 8-14 lbs

2. Turn each outer blade tip to align with the deck in a side to side manner.
3. Measure from the floor surface up to the bottom of the blade tip on the discharge side of the mower. Retain this measurement. Move to the opposite side and check to see if that measurement is the same. *If adjustment is required, turn nut on one or both of the rear L-rods until both measurements are equal.*
4. Turn each outer blade tip to align with the deck in a front to rear manner.
5. Measure from the floor surface up to the bottom of the blade tips at *both the front and rear of the blades*. Rear of blade tips should be level to 1/4" higher than the front of blade tips. If adjustment is necessary, turn nut on front L-rod.

NOTE: This will place the mower deck in a base measurement position. Additional adjustment may be required to achieve desired cut for the type of grass or conditions involved.

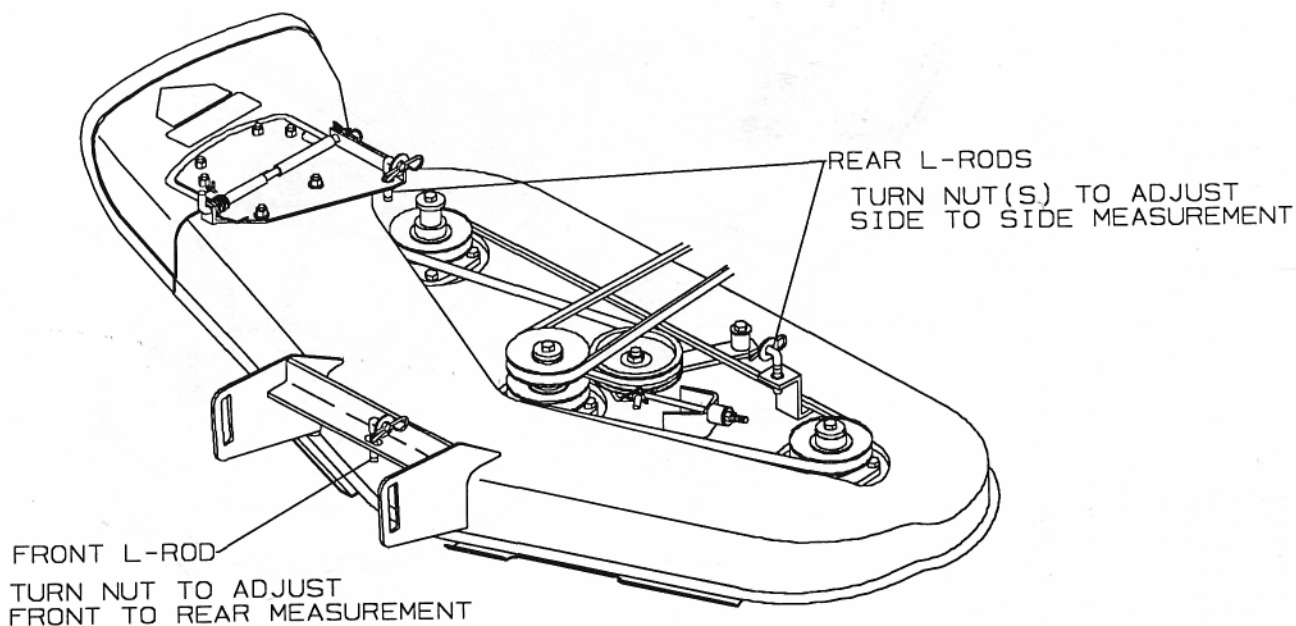

CARE AND MAINTENANCE

36" DECK REMOVAL

1. Place cut height lever in lowest cut position.
2. Loosen nut on belt idler shock mount until belt can be removed from electric clutch pulley on the bottom of the engine.
3. Remove hair pin cotter and washer from one end of deck support cross shaft. Note location of remaining shim washers used between chassis and mower deck plates. Slide shaft from chassis and mower deck.
4. Remove hair pin cotter and washer from each deck L-rod. Remove L-rods from lift arms. At this point, deck will drop down.
5. Carefully raise and support front of chassis. Slide mower deck to either side for removal. (Reverse procedure to reinstall deck assembly)

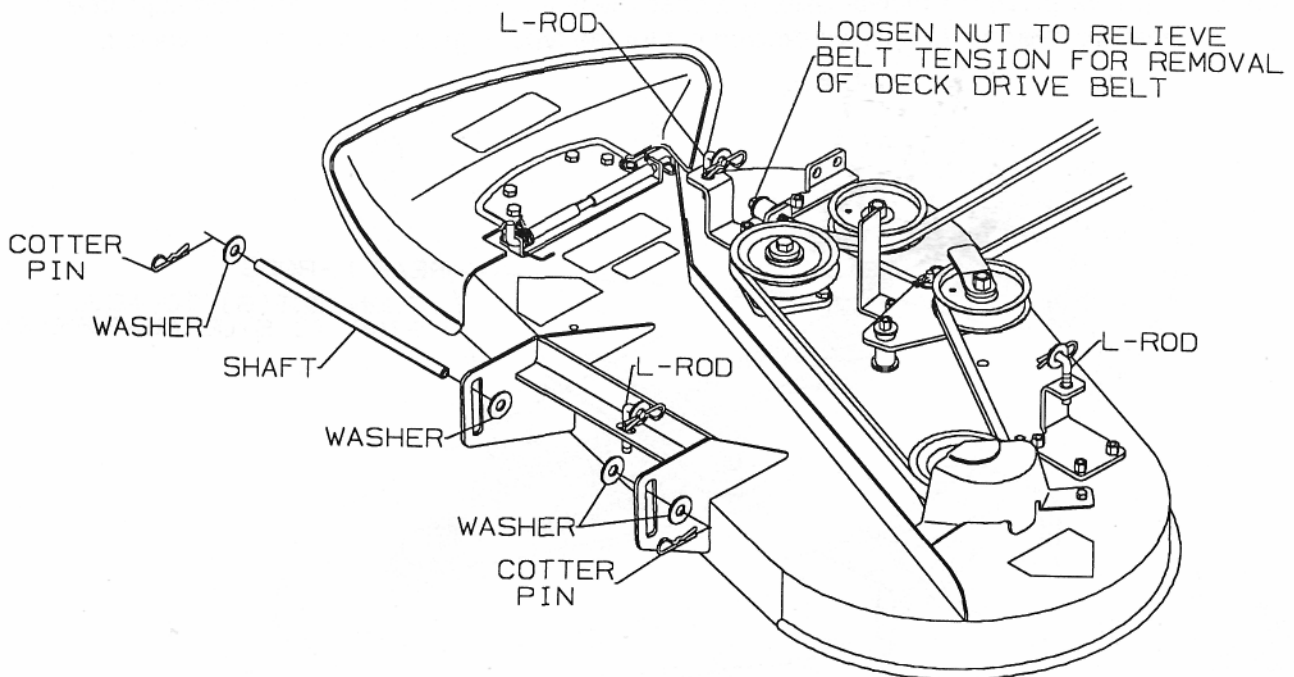

CARE AND MAINTENANCE

42" DECK REMOVAL:

1. Place cut height lever in lowest cut position.
2. Pull belt idler back to allow belt to be removed from idler pulley and electric clutch pulley.
3. Remove hair pin cotter and washer from one end of deck support cross shaft. Note location of remaining shim washers used between chassis and mower deck plates. Slide shaft from chassis and mower deck.
4. Remove hair pin cotter and washer from each deck L-rod. Remove L-rods from lift arms. At this point, deck will drop down.
5. Carefully raise and support front of chassis. Slide mower deck to either side for removal. (Reverse procedure to reinstall deck assembly).

NOTE: When deck is reinstalled on frame, check that belt is correctly routed in the grooves of all pulleys and that belt idler is applying tension to the back side of the belt.

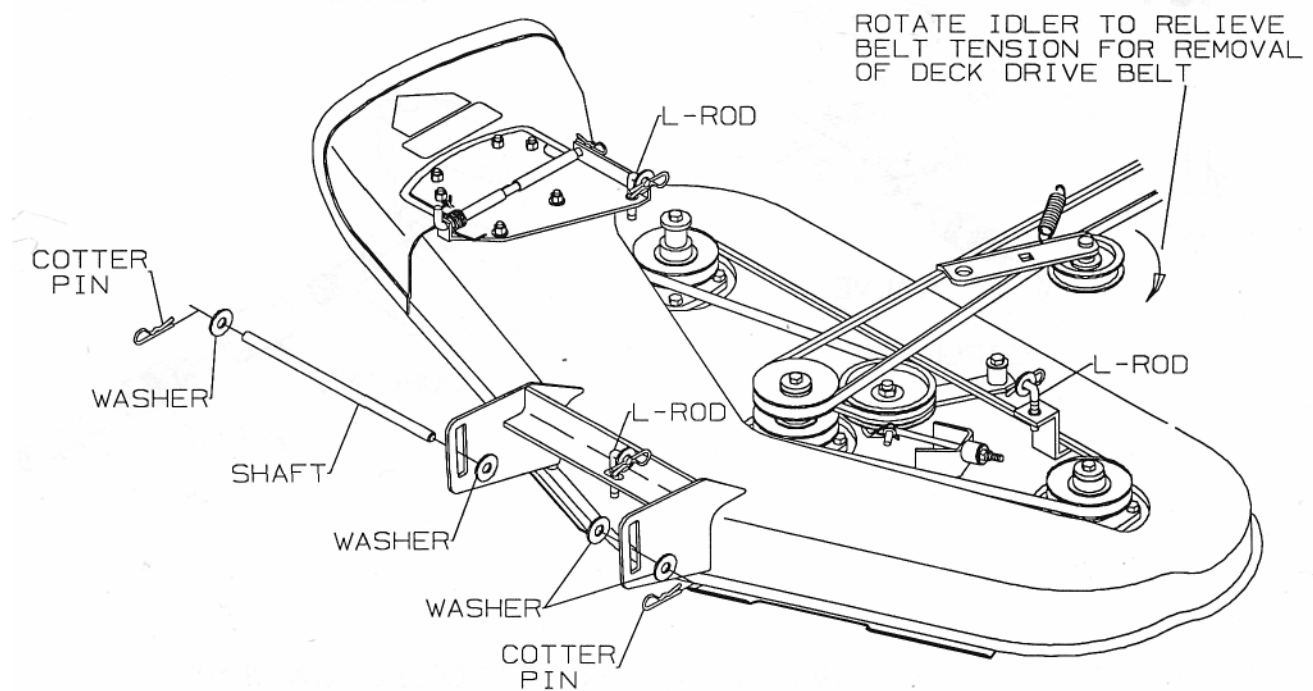

CARE AND MAINTENANCE

CAUTION HOT oil may cause burns. Allow engine to cool before draining oil.

CHANGING THE ENGINE OIL:

1. The "snap lock" oil drain valve is located on the left side of the engine crankcase.
2. Place a suitable container under the drain valve. The fitting of a short piece of hose to the valve will help direct the oil.
3. *Push* the valve body in and *twist* to clear the detent notch.
4. *Pulling* the valve body outward will start the flow of oil.

NOTE: Refer to engine manufacturers recommendations for frequency of oil changes.

MODEL 4515B

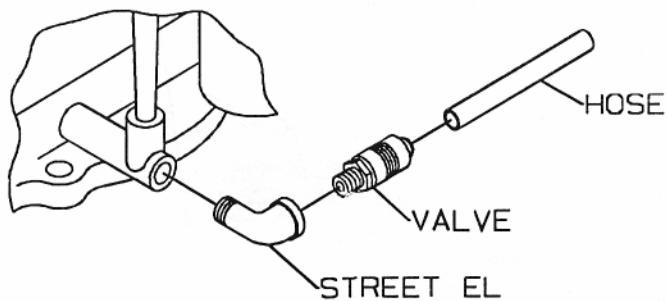

MODEL 4515K

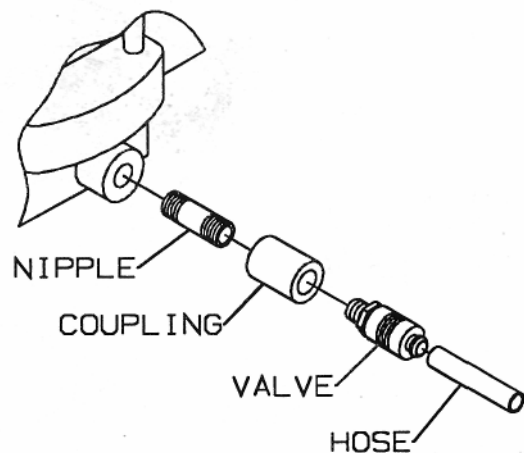

Page 28 PLEASE DISPOSE OF USED OILS AT PROPER COLLECTION CENTERS.
-PROTECT YOUR ENVIRONMENT-

CARE AND MAINTENANCE

OIL FILL:

1. Push the valve body in and twist into the detent notch.
2. Clean any spilled oil from engine and chassis.
3. Refill engine with type, and quantity of oil recommended by the engine manufacturer in engine literature.

Closed

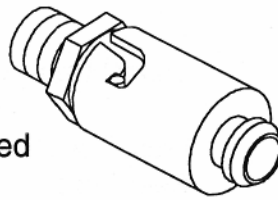

Open

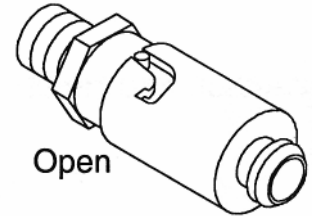

NOTE:

Oil changes require replacement of the oil filters. These filters can be obtained from your authorized engine dealer.

The use of any other oil filter may cause damage to the engine.

Model ZTR 4515B

Briggs & Stratton Oil Filter: P/N 492 932

Model ZTR 4515K

Kohler Oil Filter: P/N 52 050 02

**PLEASE DISPOSE OF USED OILS AT PROPER COLLECTION CENTERS. -
PROTECT YOUR ENVIRONMENT-**

LUBRICATION:

CHASSIS: LOCATIONS:

Number of grease zerks used: (4)

SERVICE INTERVALS:

(1) each front wheel caster tube and each front wheel hub.

RECOMMENDED GREASE:

Every 50 hours of operation

Name brand wheel bearing or multi-purpose grease

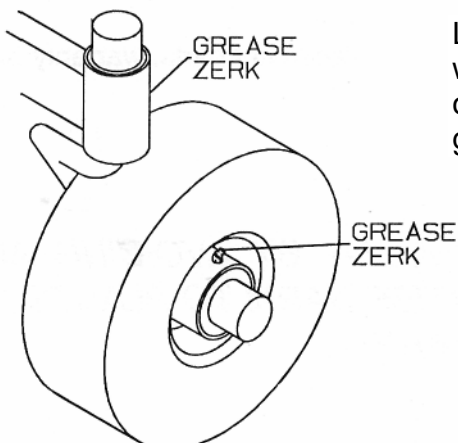

Lubricate each front wheel to allow even distribution of grease within the wheel, rotate or spin each front wheel after (3) pumps of the grease gun. Repeat process until the appearance of grease is noted completely around each caster axle.

CARE AND MAINTENANCE

WHEELS AND TIRES:

Correct tire pressure is important for correct operation of mower.
Front Tires 11X4.00X5 Air Pressure 16-21 lbs.
Rear Tires 18X8.50X8 Air Pressure 8-14 lbs.
NOTE: Check lug nuts periodically for tightness.

ELECTRICAL SYSTEMS:

Keep all connections clean and tight.

CLEANING THE MOWER:

Wash mower periodically. Clean above and below deck.
NOTE: Allow mower to cool before washing. If bearings are hot, they will draw moisture inside as they dry and cause corrosion.

SERIAL NUMBERS:

The serial number is located on frame at rear of engine, it will begin with DM.

WARRANTY:

Refer to Warranty Registration Form (P/N 5859).

PARTS/SERVICE:

See your Dixon dealer for replacement parts, warranty or service.

***PLEASE HELP PROTECT THE ENVIRONMENT BY AVOIDING ALL
CHEMICALS WHICH MAY DAMAGE OR CAUSE HARM TO PLANTS AND
ANIMALS IN YOUR AREA.***

STANDARD SERVICE PARTS LIST

36" DECK:

BLADES:	Standard:	P/N 1324
	Hi-Lift:	P/N 1351 Right Side
		P/N 1352 LeftSide
BELTS:	Engine To Mower Deck:	P/N 1300
	Engine To Transmission:	P/N 5768

42" DECK:

BLADES:	Standard Hi-Lift:	P/N 8688
	Lo-Lift:	P/N 6236
BELTS:	Engine To Mower Deck:	P/N 5861
	Serpentine Belt:	P/N 6109
	Engine To Transmission:	P/N 5768

BRIGGS & STRATTON FILTER PART NUMBERS:

Please refer to Briggs & Stratton Engine Operators Manual for correct service intervals for engine oil changes and air filter maintenance.

Protect your engine investment, use only original equipment filters.

Model ZTR 451 5B:	15HP	Precleaner Foam Element	P/N 272 403	Model ZTR 4515B: 15HP
		Air Filter Cartridge:	P/N 493 909	
		Engine Oil Filter:	P/N 492 932	Precleaner Foam Element
		Air Filter Cartridge:	P/N 493 909	
		Engine Oil Filter:	P/N 492 932	

KOHLER FILTER PART NUMBERS:

Please refer to Kohler Engine Operators Manual for correct service intervals for engine oil changes and air filter maintenance.

Protect your engine investment, use only original equipment filters.

Model ZTR 451 5K:	15HP	Air Filter Cartridge:	P/N 1208310
		Pre-Cleaner:	P/N 1208312
		Engine Oil Filter:	P/N 52 050 02

TROUBLESHOOTING

MOWER CUT QUALITY:

There are many variables that can effect the cut quality of any riding mower. Type and conditions of grass, cut height setting, engine RPM and ground speed are some of the variables that interact creating differences in cut quality. Examination of one or more of the above will generally produce a quality cut.

The Troubleshooting Chart suggests practices and adjustments that may be helpful in improving cut quality. Your Dixon ZTR dealer is also available to provide assistance to you.

<u>SITUATION</u>	<u>CAUSES</u>	<u>REMEDY</u>
Poor cut quality	Ground speed	Reduce mowing speed
Poor cut quality	Incorrect engine to mower deck belt	Refer to page 31 for part numbers
Poor cut quality	Engine RPM too low	Increase engine RPM to maximum
Poor cut quality	Dull or bent blade	Sharpen or replace as required
Poor cut quality	Un-level mower deck	Refer to page 25 for deck leveling procedure
Poor cut quality	Grass buildup under mower deck	Clean out underside of mower deck
Poor cut quality	Improper blades	Refer to page 31 for part numbers
Poor cut quality	Uneven tire pressures	Refer to page 30 for correct tire pressures

DRIVE SYSTEM:

SITUATION	CAUSES	REMEDY
Mower creeps in neutral position	Neutral adjustment	Refer to page 24 for procedure or consult your dealer for repair
Mower pulls to one side or the other	Forward travel speed adjustment	Refer to page 23 for procedure
Loss of power and speed on both sides	Incorrect or worn drive belt Spring on idler arm missing or broken Idler arm will not pivot Internal malfunction	Replace belt Replace spring Remove cause of seizure and lubricate Consult your dealer for repairs
Drive system functions on one side only	Incorrect or worn drive belt Spring on idler arm missing or broken Idler arm will not pivot Internal malfunction	Replace belt Replace spring Remove cause of seizure and lubricate Consult you dealer for repairs

TROUBLESHOOTING

ELECTRICAL SYSTEM:

SITUATION	CAUSES	REMEDY
Starter will not turn engine over	Circuit breaker disengaged	Push button to reset Consult your dealer for repair
Starter will not turn engine over	Dead battery	Charge battery
Battery discharge	Poor connections on battery Battery water low Wrong battery installed in mower	Tighten or replace as required
Battery discharge	Engine electrical system not functioning correctly	Have electrical system checked by your dealer
Battery discharge	Engine not being operated at full throttle	increase engine RPM Contact your dealer for information

NOTE: Electrical system failures are generally simple in nature, always check the obvious first and then move onto the more complicated parts used.

Poor battery service, loose connections, corrosion, frayed or broken wiring, are more likely than component failure.

OWNER INFORMATION



DIXON INDUSTRIES, INC.
A **BLOUNT** International Inc. Co.
PO BOX 1569
COFFEYVILLE KS 67337 0945
316251 2000
FAX 316 251 4117



DATE PURCHASED _____

MOWER MODEL NUMBER _____

MOWER SERIAL NUMBER **DM-** _____

PURCHASED FROM _____

Name

Address

DATE OIL CHANGED:

DATE ENGINE TUNED:



⚠ WARNING: The Engine Exhaust from this product contains chemicals known to the State of California to cause cancer, birth defects or other reproductive harm.

©Dixon and ZTR are registered trademarks of Dixon Industries, Inc.

DIXON INDUSTRIES, INC.
A BLOUNT International Inc. Co.
PO BOX 1569
COFFEYVILLE KS 67337 0945
316251 2000

4500 Series
Part No. 5863
MY98 mn1/98

Free Manuals Download Website

<http://myh66.com>

<http://usermanuals.us>

<http://www.somanuals.com>

<http://www.4manuals.cc>

<http://www.manual-lib.com>

<http://www.404manual.com>

<http://www.luxmanual.com>

<http://aubethermostatmanual.com>

Golf course search by state

<http://golfingnear.com>

Email search by domain

<http://emailbydomain.com>

Auto manuals search

<http://auto.somanuals.com>

TV manuals search

<http://tv.somanuals.com>