



OPERATOR'S MANUAL FOR ZTR-301, 302 MOWER

IMPORTANT!

The Dixon ZTR mower is both easy and fun to operate. However, any power mower must be operated properly to be safe. It is not a toy or a recreational vehicle. Before you start to use the mower, read the operator's manual carefully, and become completely familiar with the controls. Your Dixon dealer will gladly provide a check-out ride, and answer any questions.

READ CAREFULLY

You have purchased a top quality lawn mower that has been inspected at the factory and found to be in perfect mechanical condition. This lawn mower is warranted for 1 year from date of delivery against all defects in materials and workmanship. Lawn mowers used for commercial service are warranted for 30 days from date of delivery.

ONE-YEAR LIMITED WARRANTY

This lawn mower is warranted for one(1) year from date of delivery against all defects in materials and workmanship. Lawn mowers used for commercial service are warranted for 30 days from date of delivery. (Lawn mowers other than those used only at residence of owner are considered as commercial service.)

Each new mower is warranted against manufacturing defects in material and workmanship under normal use and service. Our obligation, under this warranty, shall be limited to the replacement to the original retail purchaser of any part or parts, which, within the warranty period, shall be shown to be defective due to faulty workmanship or materials at the factory. All parts claimed defective must be returned to the factory for inspection, repair, or replacement with transportation charges prepaid.

This warranty does not apply to damage in transit or damage caused by misuse, negligence or accident, to alterations or repairs done outside the factory or authorized service stations, nor does it obligate us to assume any transportation charges in connection with the replacement of parts claimed to be defective.

Our warranty does not apply to the blades, adapters, chains or belts on our mowers due to the very nature of the function they perform and to the elements they are exposed to.

The warranty specifically excludes engines and tires which are warranted separately by their respective manufacturers. All claims for defective engines or engine parts must be made in accordance with the engine manufacturer's warranty.

We reserve the right to make changes in design and changes or improvements on our product without imposing any obligation upon ourselves to install the same on products heretofore manufactured.

This warranty is null and void if any parts other than original manufacturer's parts are used. There is no other express warranty.

IMPLIED WARRANTIES, including those of merchantability and fitness for a particular purpose, are limited to one(1) . year from purchase and, to the extent permitted by law, any and all implied warranties are excluded.

SERIAL NUMBERS

The lawn mower has two serial numbers:

Mower Number — Located on frame at right rear transaxle mount. Transaxle Number — Located on transaxle.

SAFETY INSTRUCTIONS

BEFORE MOWING:

1. Discuss proper maintenance with your Dixon dealer, to save money and prevent injury. Consult your dealer before removing any parts.
2. Don't allow anyone to operate your Dixon mower without proper instruction. Young children should never be allowed to operate any power mower, riding or walking.
3. Before mowing, pick up all debris — particularly stones and sharp objects.
4. Before starting the engine, make sure the gas cap is in place.

DURING MOWER OPERATION 1. The revolutionary Dixon mower attracts many admiring neighbors. But when mowing, all persons — especially children — and pets should be cleared from the mowing area.

2. Wear appropriate, safe clothing when mowing — close-fitting jeans or slacks and heavy leather or safety shoes with rough soles. Never use any kind of mower with bare feet or open sandals, not even an old push-type model!
3. When grass is wet or slippery, do not use any riding mower.
4. Always mow at the slowest speed that will cut satisfactorily.
5. Keep hands and feet away from the blade at all times.
6. Although the Dixon mower is equipped with a missile deflector which directs downwards all blade propelled objects, keep persons clear of the discharge chute.
7. Your Dixon mower is very stable because of its low center of gravity and weight biased to the rear; however, caution should be exercised when mowing hills or slopes with *any* mower.
8. Always disengage blades before taking the mower

- across walks or objects that project above the surface. 9. When the mower is not in use, turn the engine off; never leave the engine running unattended. Your Dixon mower is equipped with a weight-sensitive switch that kills the engine when operator leaves the seat while blades are engaged.
10. Before adjusting your mower or adding fuel, turn the engine off. Let it cool, and disconnect the spark plug so the engine cannot start by accident. Be sure all moving parts are stopped.

11. Never run the engine indoors; the fumes are dangerous.
12. Before backing your Dixon mower, stop, turn around, and look.
13. Gasoline fumes are explosive; use only approved gasoline containers to store small amount of fuel. No special oil/gas mixtures are needed for your Dixon mower.
14. If the mower should start vibrating, stop the engine immediately and check for damage or loose parts. Vibration is usually the warning of trouble.
15. Never lift lawn mower by the body; lift only by the frame.

ALWAYS SET PARKING BRAKE AND DISENGAGE BLADE OPERATION BEFORE DISMOUNTING

IMPORTANT OPERATING INSTRUCTIONS

Dixon ZTR mowers offer a new concept in mowing, providing unique maneuverability and ease. The following procedures will allow one to become familiar with the unique method of control very easily.

- 1. SET PARKING BRAKE** — Be sure that drive levers are free. (When drive levers are released, they will return to neutral position.)
2. Move "Blade Operation" lever to "Disengage" position. ... Engine will not start when blades are engaged.

3. Move throttle control to "Choke" position.
4. To start models with electric starting, simply insert ignition key and turn to the far right position. When the engine starts, release the ignition key and it will remain in the "RUN" position. To stop the engine simply turn the key to the "OFF" position. To start manual start models, turn switch to "RUN" position. A sharp pull will start the engine. Release the start-

ing rope as soon as engine starts. To stop engine turn key to "OFF" position.

5. Set engine to desired speed by adjusting throttle control. (Suggest set at slow speed during initial operation.)
6. NOTE SAFETY FEATURE: Engine stops automatically if operator leaves seat while blades are engaged.
7. This unit is equipped with a unique transaxle that requires only two drive levers to control braking, turning, direction and acceleration.

TO GO FORWARD:

From neutral position push both drive levers slightly forward; to increase speed move levers further forward. **TO GO**

BACKWARD:

From neutral position pull both drive levers slightly rearward.

TURNING:

Turning is controlled by moving one drive lever slightly forward or rearward of the other. To turn left, move left lever rearward of right lever. To turn "square corners" move lever of desired direction to neutral. To turn on mower's own axis (Zero radius) reduce speed and move one lever to reverse position and the other to forward position.

BRAKING:

To brake mower, move both levers in direction opposite of travel, release levers to neutral, set parking brake. When stopping on incline, it may be necessary to hold slight pressure on levers in direction opposite of slope, until parking brake is set.

ALWAYS SET PARKING BRAKE BEFORE DISMOUNTING.

INITIAL OPERATION:

It is recommended that first operation of mower be done at a slow setting of throttle speed and disengagement of mower blades until operator is thoroughly familiar with the unit.

You may have tendency to "over control" mower at first.

Slight movements — fingertip control — is all that's

necessary for easy operation. 8. Mower Blade Operation:

- Cutting height is set by positioning the adjustment lever. Push button knob on top of lever, set desired cutting height, lock into position by releasing button knob.
- To start mower blades, move lever on floor to "engage" position. To stop mower blades, move lever to "disengage" position.

ALWAYS DISENGAGE BLADE OPERATION BEFORE DISMOUNTING.

9. Parking Brake:

Parking brake is hand operated and is located at right-hand side of mower. To disengage move lever forward. To engage brake pull lever to the rear. Always set parking brake before dismounting. Be sure that parking brake is disengaged before moving mower.

MAINTENANCE

PRE-STARTING INSTRUCTIONS

1. Fill fuel tank with a good grade of regular gasoline. Do not mix oil with gasoline.
2. Attach the spark plug wire to the spark plug.
3. With mower on a level surface, fill the crankcase with a good grade of multi-purpose 10 - 30 oil as outlined in the engine instruction manual.
4. On model equipped with a battery be sure the battery is filled to proper fluid level with electrolite solution. After initial filling, level may be retained with distilled water.

CAUTION:

5. During initial "Break In" period, the oil level should be checked often.
6. Check oil level every five operating hours or each time mower is used.
7. Change oil every 25 operating hours or sooner if equipment is operated in extremely dusty conditions.

BELT ADJUSTMENT

Main Drive Belt - This belt should be kept taut to lengthen belt life and prevent loss of power. To tension belt, loosen 4 bolts which hold the engine to the mount and the lock nut on the tension bolt at the rear of the machine. Tighten tension bolt until belt is taut and retighten the 4 bolts holding engine and tighten tension bolt lock nut.

MOWER DRIVE BELT

Belt tension for the mower drive belt is adjusted by turning the turnbuckle to provide more forward movement of the engaging idler.

REPLACE BELTS WHEN ADJUSTMENT CAN NO LONGER BE MADE SATISFACTORILY OR IF BELTS BECOME WORN.

BODY REMOVAL FOR ZTR-301 / 302

1. Disconnect throttle cable from engine by loosening clamp on engine and disconnecting cable.
2. Disconnect two (2) switch loom plugs, one going to engine wires and one going to frame wire loom. Plugs are located back of transaxle mount.
3. Remove four (4) control lever bolts and remove upper control levers.
4. Remove engaging handle by removing bolt and nut under handle.
5. Remove four (4) attach bolts on floor.
6. Remove two (2) sheet metal screws from transaxle mount. Body will now lift clear. To replace body, reverse the above procedure. Remember to reinstall switch ground wire on left rear transaxle body mount screws.

CHAIN ADJUSTMENT

To adjust the drive chains, the body must be removed and shims added behind the transaxle. Loosen 4 bolts which hold the transaxle to the frame. Insert shims (Pt. No. 2221 or 2222) as needed for adjustment between transaxle and mount plates. Tighten the 4 bolts which hold the transaxle to the frame. A few drops of oil periodically will lengthen

chain life. Replace chain when rollers become loose, chain breaks, or chain fails to operate properly. **WHEELS AND TIRES**
Correct tire pressure is essential to correct operation of the mower. The correct pressure for the drive tires is 14 -16 lbs. Lug nuts should be checked periodically. Front tires are semi-pneumatic and do not require inflation. **ELECTRICAL SYSTEMS**
Keep all connections clean and tight. Maintain the fluid in the battery at correct level.

BODY

The body may be washed with a mild detergent and waxed with any automotive type wax.

ENGINE

Follow the manufacturer's instructions as to maintenance and repair. A copy of these instructions are supplied with each mower.

TRANSAXLE

For adjustment or repair confer with authorized Dixon dealer service department. Adjustment or repair by other than authorized dealer voids warranty.

SPARE PARTS

See your dealer for ordering spare parts or warranty service.

REMOVING AND REINSTALLING MOWER DECK

1. Remove engaging handle by removing bolt and nut under handle.
2. Disconnect mower deck wire loom from frame wire loom.
3. Loosen belt keeper located under engine by loosening two (2) rear engine mount bolts to allow mower deck drive belt to come free of rear pulley. Retighten belt keeper.
4. Remove six (6) attach pins and clips from four (4) mower deck attach points and two (2) stabilizer bars.
5. Mower deck may then be removed from unit for service or replacement. To reinstall, reverse the above procedure.

BODY ASSEMBLY

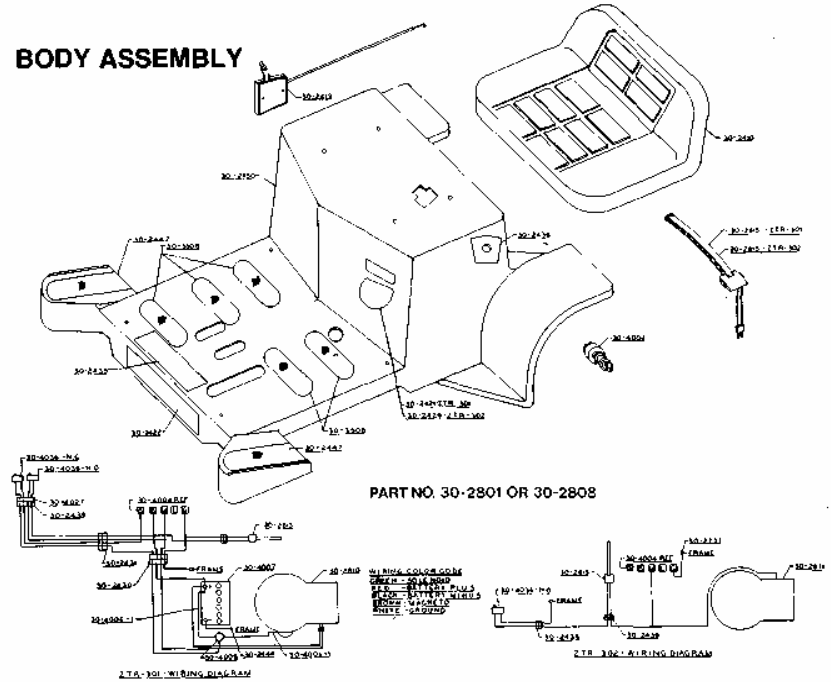

CHASSIS ASSEMBLY

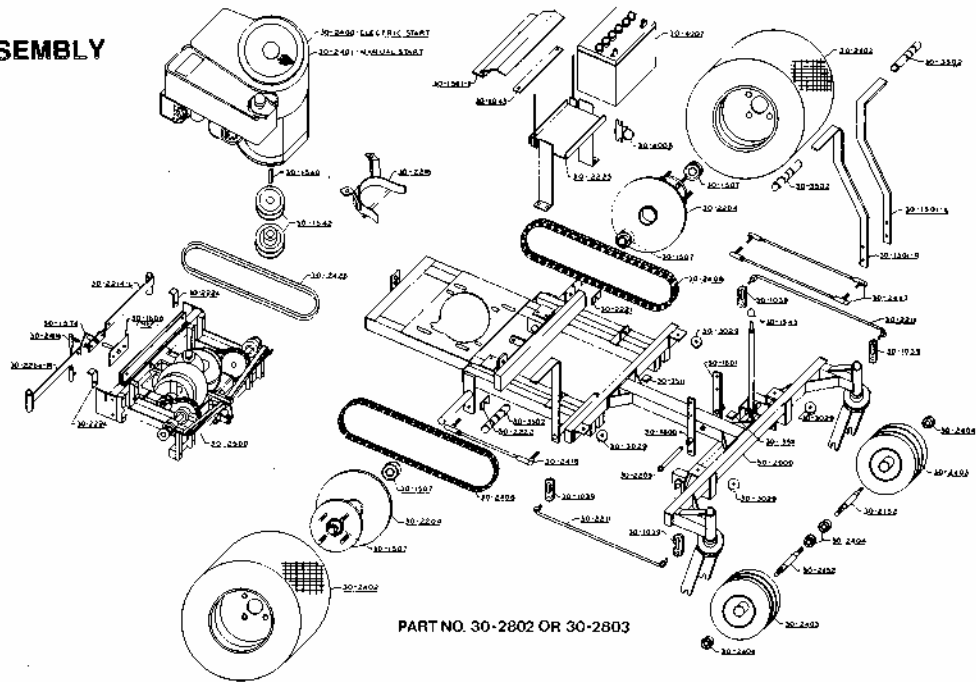

PART NO. 30-2802 OR 30-2803

MOWER DECK ASSEMBLY

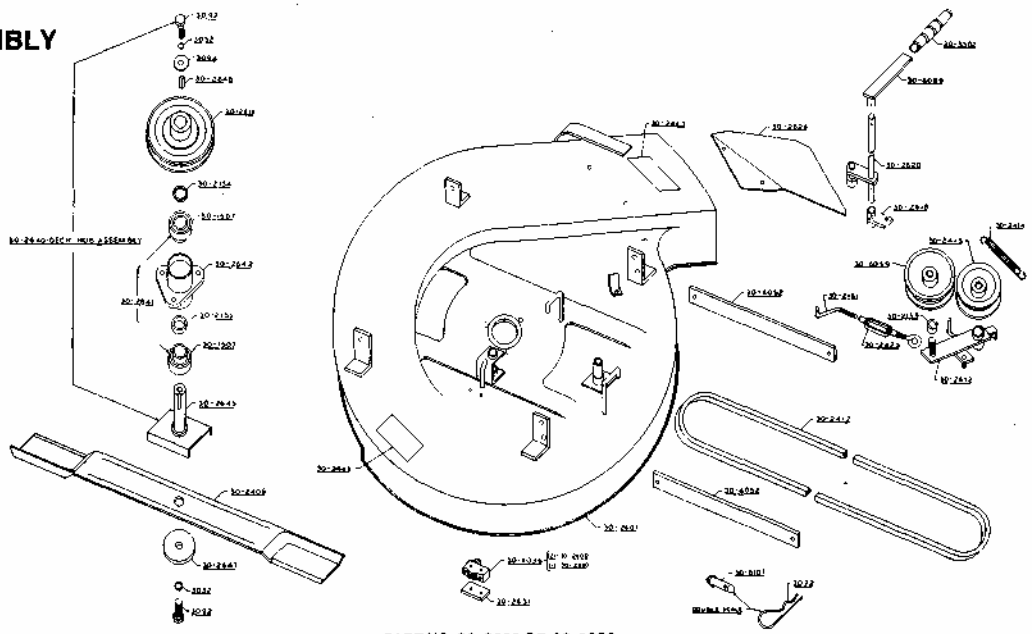

PART NO. 30-2600 OR 30-2650

Part No.	Name
30-1039	Lower Lift Link
30-1043	Battery Strap
30-1501R	Upper Control Lever - Right
30-1501L	Upper Control Lever - Left
30-1507	Wheel/Mower Deck Bearing
30-1530	Bellcrank Weldment
30-1536	Chain Connecting Link
30-1540	Engine Shaft Key
30-1542	V-Pulley
30-1543	Lift Knob
30-1560-1	Battery Splash Guard
30-1574	Brake Pivot
30-1604	Lower Control Pin
30-1606	Brake Mount
30-2000	Frame Weldment
30-2150	Blue Body - ZTR-301/302
30-2152	Caster Axle
30-2154	Deck Hub Pulley Spacer
30-2155	Deck Hub Bearing Spacer
30-2159	Engaging Idler Spacer
30-2161	Connecting Link
30-2164	Support Sprocket Spacer
30-2165	Torque Rod
30-2166	Pivot Bolt

Part No.	Name
30-2201	Lower Control Lever - Left
30-2202	Lower Control Lever - Right
30-2203	Wheel Hub & Sprocket Assembly
30-2209	Lower Lever Pin
30-2212	Lift Tie Rod
30-2214	Brake Arm
30-2216	Belt Keeper
30-2220	Engine Tension Plate
30-2221	Transaxle Shim (16 Ga.)
30-2222	Transaxle Shim (22 Ga.)
30-2224	Brake Clip
30-2225	Battery Box Weldment
30-2402	Rear Wheel & Tire
30-2403	Caster Wheel & Tire
30-2404	Caster Wheel Bearing
30-2406	Blade
30-2408	Drive Chain
30-2410	ZTR-301/302 Seat
30-2411	Deck V-Pulley
30-2412	DeckV-Belt
30-2413	V-Idler Pulley
30-2414	Idler Tension Spring
30-2416	Short Brake Rod
30-2417	Control Rod Assembly

Part No.	Name
30-2418	Long Brake Rod
30-2419	Throttle Control
30-2421	Model Decal, ZTR-301
30-2422	Name Decal, ZTR-301/302
30-2425	Tumbuckle
30-2426	Drive V-Belt
30-2429	Model Decal, ZTR-302
30-2430	Rear Wire Loom, ZTR-301
30-2432	Frame Wire Loom, ZTR-301
30-2433	Engine Connector Plug
30-2434	Cam Switch Spring
30-2435	Control Decal, ZTR-301/302
30-2436	Switch Decal
30-2437	Switch Ground Wire, ZTR-302
30-2438	Pan Wire Loom, ZTR-302
30-2439	Frame Wire Loom, ZTR-302
30-2443	Deck Caution Decal
30-2444	Battery to Ground Wire
30-2445	Fuel Tank Decal
30-2446	Seat Switch Loom, ZTR-302
30-2500	Transaxle
30-2501	Rear Tube Weldment
30-2504	Front Tube
30-2505	Support Assembly - Left

Part No.	Name
30-2506	Support Assembly - Right
30-2507L	Support - Left
30-2507R	Support - Right
30-2509	Support Shaft
30-2514	Torque Rod Stiffener - RH
30-2515	Torque Rod Stiffener - LH
30-2519	Cradle Assembly - Left
30-2520	Cradle Assembly - Right
30-2600	Mower Deck Assembly
30-2601	Mower Deck Weldment
30-2612	Engaging Idler
30-2618	Engaging Cam
30-2620	Engaging Rod
30-2626	Deflector
30-2631	Pan Switch Spacer
30-2640	Deck Hub Assembly
30-2641	Deck Hub Sub-Assembly
30-2642	Deck Hub
30-2645	Blade Shaft
30-2647	Blade Washer
30-2648	Deck Hub Key
30-2812	Oil Drain Assembly
30-2813	Seat Switch Assembly, ZTR-301
30-2815	Seat Switch Assembly, ZTR-302

Part No.	Name
30-3025	1/4 x 1" Spiral Pin
30-3026	1/4 x 1-1/2" Spiral Pin
30-3029	Grommet
30-3032	1/2" Lockwasher
30-3042	Pivot Bolt Locknut (7/16-14)
30-3054	3/16 x 1" Roll Pin
30-3057	3/8" Flat Washer
30-3059	Spring Clip
30-3070	1/4 x 1-1/4" Spiral Pin
30-3072	Hair Pin Cotters (Mower Deck)
30-3092	1/2-20, 1-1/4 CL. 5 Bolt
30-3094	1/2" Flat Washer
30-3502	Hand Grip
30-3504	Double Ball Joint
30-3508	Floor Pad - Short
30-3511	Adhesive Rear Grommet
30-4004	Switch
30-4006-1	Battery Solenoid Cable
30-4007	Battery
30-4008	Solenoid
30-4027	Pan Wire Loom, ZTR-301
30-4036	Micro Switch
30-5005	Discup
30-5007	Center Frame

Part No.	Name
30-5009L	Cradle - Left
30-5009R	Cradle - Right
30-5012	Cradle Shaft
30-5013	Frame Shaft
30-5015	24 T Sprocket
30-5016	Cone (Set of Two)
30-5018	9 T Sprocket - Narrow
30-5019	Chain
30-5021	9 T Sprocket - Wide
30-5022	Thumb Screw
30-5024	Cradle Spring
30-5025	Frame Assembly
30-5028	Bearing
30-5028-A	Bearing - Notched
30-5035	Transaxle Pulley
30-5036	Pivot Spring
30-5046	Positive Neutral Rod
30-5047	Positive Neutral Spring
30-6052	Stabilizer Arm
30-6059	Flat Idler Pulley
30-6089	Engaging Handle
30-6107	Deck Pin

OWNER INFORMATION

Date Mower Purchased _____ Mower Model Number _____

Mower Purchased from _____
dealer name & address

Mower serial number _____ Transaxle Serial Number _____

Oil changed this date:

1. _____

4. _____

2. _____

5. _____

3. _____

6. _____

Engine tuned this date:

1. _____

3. _____

2. _____

4. _____

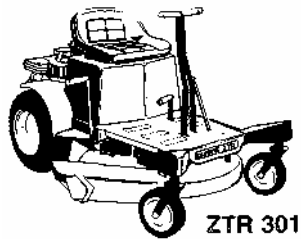

ZTR 301

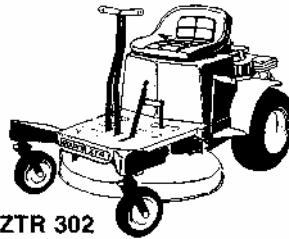

ZTR 302

Form No. 1449-177

 Dixon and ZTR are the trademarks of Dixon Industries, Inc., Box 494, Coffeyville, Kansas 67337

LITHO IN U.S.A.

Free Manuals Download Website

<http://myh66.com>

<http://usermanuals.us>

<http://www.somanuals.com>

<http://www.4manuals.cc>

<http://www.manual-lib.com>

<http://www.404manual.com>

<http://www.luxmanual.com>

<http://aubethermostatmanual.com>

Golf course search by state

<http://golfingnear.com>

Email search by domain

<http://emailbydomain.com>

Auto manuals search

<http://auto.somanuals.com>

TV manuals search

<http://tv.somanuals.com>