

**DIXON**®

**ZTR**®

**6601  
SERIES**

**OPERATORS MANUAL**

---

## IMPORTANT - READ CAREFULLY

The Dixon **@ZTR@** Mower is both easy and fun to operate. However, any power mower must be operated properly to be safe. It is not a toy or a recreational vehicle. Before you start to use the mower, read the operator's manual carefully and become completely familiar with the controls.

The information in this operator's manual applies to all Dixon **@ZTR@** Model 6601 Mowers. Your Dixon dealer will gladly provide a check-out ride and answer any questions.

See your dealer for warranty service, parts and repairs.



DIXON INDUSTRIES, INC  
A BLOUNT COMPANY  
AIRPORT INDUSTRIAL PARK  
PO BOX 1569  
COFFEYVILLE KS 67337 0945  
316 251 2000  
FAX 316 251 4117

**BLOUNT**

---

# INDEX

SAFETY .....	Pages 1 - 6
WARRANTY POLICY .....	Page 7
SPECIFICATIONS .....	Page 8
SEAT ADJUSTMENT .....	Page 9
CONTROLS .....	Pages 10-13
OPERATION INSTRUCTIONS .....	Pages 14-18
CARE AND MAINTENANCE .....	Pages 19-33
STANDARD SERVICE PARTS LIST .....	Page 34
TROUBLESHOOTING .....	Pages 35-37
DIAGRAMS .....	Pages 38-44

**Part No. 8946**  
September 1995

---

# SAFETY

*RIDING LAWNMOWERS, IF IMPROPERLY OPERATED,  
CAN CAUSE SERIOUS INJURY OR DEATH*

*The most common causes of injury to the operator or bystander...*

**BLADE CONTACT**

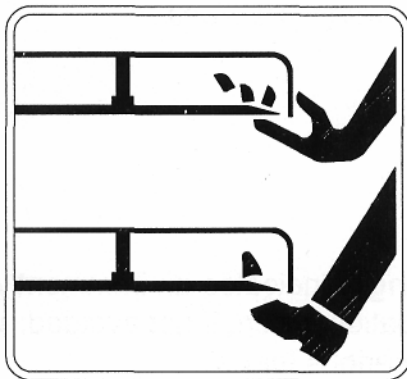

**RUN-OVER**

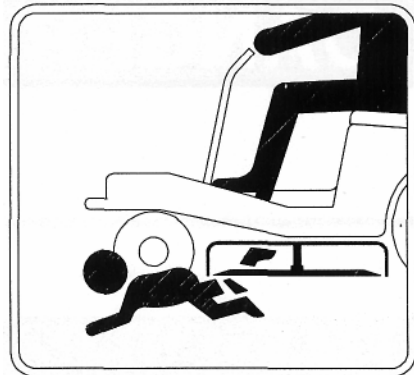

**TIP-OVER**



**RUN-OVER**

---

# SAFETY

## SAFETY SYMBOLS:



### SAFETY ALERT SYMBOL -

When you see this symbol,  
BE ALERT to the potential for injury.

*Follow recommended safety precautions and safe operating practices.*



**Danger** indicates an imminently hazardous situation which, if not avoided, *will* result in death or serious injury.



**Warning** indicates a potentially hazardous situation which, if not avoided, *could* result in death or serious injury.



**Caution** indicates a potentially hazardous situation which, if not avoided, may result in minor or moderate injury. It may also be used to alert against unsafe practices.

---

# SAFETY

*This cutting mower is capable of amputating hands and feet, and throwing objects. Failure to observe the following safety instructions could result in serious injury or death.*

## **GENERAL OPERATION:**

- Read, understand, and follow all instructions in the manual and on the mower before starting.
- Only allow responsible adults, who are familiar with the instructions, to operate the mower.
- Clear the area of objects such as rocks, toys, wire, etc., which could be picked up and thrown by the blade.
- Be sure the area is clear of other people before mowing. Stop mower if anyone enters the area.
- Never carry passengers.
- Do not mow in reverse unless absolutely necessary. Always look down and behind before and while backing.
- Be aware of the mower discharge direction and do not point it at anyone. Do not operate the mower without either the entire grass catcher or the deflector in place.
- Slow down before turning.
- Never leave a running mower unattended. Always turn off blades, set parking brake, stop engine, and remove key before dismounting.
- Turn off blades when not mowing.
- Stop engine before removing grass catcher or unclogging chute.
- Mow only in daylight or good artificial light.
- Do not operate the mower while under the influence of alcohol or drugs.
- Watch for traffic when operating near or crossing roadways.
- Use extra care when loading or unloading the mower into a trailer or truck. Do not ride the mower when loading & unloading.

 **WARNING:** The Engine Exhaust from this product contains chemicals known to the State of California to cause cancer, birth defects or other reproductive harm.

---

 **SAFETY****SLOPE OPERATION:**

*Slopes are a major factor related to loss-of-control and tip-over accidents, which can result in severe injury or death.*

*All slopes require extra caution.*

*If you cannot back up the slope or if you feel uneasy on it, do not mow it.*

**DO**

Mow across the slope with your Dixon ZTR - never up or down.

Remove obstacles such as rocks, tree limbs, etc.

Watch for holes, ruts or bumps. Uneven terrain could overturn the mower. Tall grass can hide obstacles.

Use slow speed.

Use extra care with grass catchers or other attachments. These can change the stability of the mower.

Keep all movement on the slopes slow and gradual. Do not make sudden changes in speed or direction.

Avoid starting or stopping on a slope. If tires lose traction, disengage the blades and proceed slowly down the slope.

**DO NOT**

*Do not* turn on slopes unless necessary, and then, turn slowly and gradually downhill, if possible.

*Do not* mow near drop-offs, ditches, or embankments. The mower could suddenly turn over if a wheel is over the edge of a cliff or ditch, or if an edge caves in.

*Do not* mow on wet grass. Reduced traction could cause sliding. *Do*

*not* try to stabilize the mower by putting your foot on the ground. *Do*

*not* use grass catcher on steep slopes.

---

 **SAFETY****CHILDREN:**

*Tragic accidents can occur if the operator is not alert to the presence of children.*

*Children are attracted to lawn mowers and the mowing activity.*

*NEVER assume children will stay where they were last seen.*

*Be alert to avoid accidents.*

- <sup>9</sup> Keep children out of the mowing area and under the watchful care of another responsible adult.
- Be alert and turn mower off if a child enters the area.
  - Before and during backing, look behind and DOWN for small children.
  - Never carry children. They may fall off and be seriously injured or interfere with safe mower operation.
  - Never allow children to operate the mower.
  - Use extra care when approaching blind corners, shrubs, trees, or other objects that may obscure vision.



---



# SAFETY

## SERVICE:

- Use extra care in handling gasoline and other fuels. They are flammable and vapors are explosive.
  - Use only an approved container.
  - Never remove gas cap or add fuel with the engine running. Allow engine to cool before refueling. Do not smoke.
  - Never refuel the mower indoors.
  - Never store the mower or fuel container inside a building where there is an open flame.
- Never run a mower inside a closed area.
- Keep nuts and bolts, especially blade attachment bolts, tight and keep equipment in good condition.
- Never tamper with safety devices. Check their proper operation regularly.
- Keep mower free of grass, leaves, or other debris buildup. Clean up oil or fuel spillage. Allow mower to cool before storing.
- Stop and inspect the equipment if you strike an object. Repair, if necessary, before restarting.
- Never make adjustments or repairs with the engine running.
- Grass catcher components are subject to wear, damage, and deterioration, which could expose moving parts or allow objects to be thrown. Frequently check components and replace with original equipment parts, when necessary.
- Mower blades are sharp and can cut. Wrap the blade(s) or wear gloves, and use extra caution when servicing them.
- Batteries contain sulfuric acid. To prevent burns avoid contact with skin, eyes and clothing. To prevent a fire or explosion keep sparks and open flames away from battery.
  - Before disconnecting the negative (-) ground cable, make sure all switches are OFF.
- Check to assure that the drive chains are properly adjusted. A loose chain may come off causing loss of control. This statement applies to chain drive models ZTR 2301, 3000 & 4000 Series.

---

## DIXON LIMITED WARRANTY POLICY -- HYDRO-GEAR MODELS

This warranty policy applies to all HydroGear mowers or any 50" model, purchased on or after March 1, 1990.

WARRANTY: Dixon Warranty term is for a period of one (1) year from date of purchase or 400 hours of use, whichever occurs first. Mowers used for residential homeowner applications (used only at owner's primary place of residence) are warranted for two (2) years from date of purchase or 400 hours of use, whichever occurs first. DIXON ZTR MOWERS ARE WARRANTED AGAINST DEFECTS IN MATERIALS AND WORKMANSHIP AND PROVIDES FOR REPLACEMENT OR REPAIR OF PARTS INCLUDING LABOR COSTS. THIS WARRANTY IS SUBJECT TO THE FOLLOWING CONDITIONS AND LIMITATIONS:

1. Warranty applies only to original retail purchaser of new and unused mowers and accessories.
2. All Dixon warranty must be accomplished by authorized Dixon dealers and in accordance with Dixon warranty policy and allowances. All warranty claims must be approved by Dixon Industries, Inc.
3. Battery warranty: Limited to 90 days from date of purchase.
4. Accessories Warranty (Grass Catchers, Snow Blades, Tine Rakes, Covers, etc.): Limited to 90 days from date of purchase.
5. Warranty does not apply to damage in transit or incidents of misuse, negligence, accidents, or alteration. The use of parts or components other than those supplied by Dixon Industries, Inc. VOIDS ALL WARRANTY.
6. The following items are not covered by this warranty policy:
  - (a) Pick up and delivery charges for transportation of mower to and from an Authorized Dixon Dealer's place of business.
  - (b) Routine maintenance or adjustments.
  - (c) Belts / chains / sprockets / cutting blades.
  - (d) Engines -- All engines used on Dixon ZTR mowers are warranted by each individual engine manufacturer.
  - (e) Any costs or expense of providing substitute equipment while repair work is being performed on a warranted mower.
7. There is no other express warranty. Implied warranties, including those of merchantability and fitness for a particular purpose, are limited to the same duration of the express warranty, and to the extent permitted by law any and all implied warranties are excluded. Liabilities for consequential damages under any and all warranties are excluded.

WARRANTY VALIDATION: At the time of sale, selling dealer must review each portion of this warranty document, complete the information section below, secure customer's signature and send copy to Dixon Industries, Inc.

DATE OF PURCHASE _____	Model _____	S/N _____	DM- _____
_____ (Owner's Name)	_____ (Dealership)		
_____ (Address)	_____ (Address)		
_____ (Owner's Signature)	_____ (Dealer's Signature)		

**SEE DEALER FOR DETAILS**

---

# SPECIFICATIONS

## Model ZTR 6601

<b>CHASSIS:</b>	1 1 GA - rectangular tube
<b>BODY:</b>	Two piece - made of rotational molded polyethylene. Front body contains access panels for battery service and engine to mower deck belt removal. Rear body tilts up to allow service on the entire drive system.
<b>SEAT:</b>	Economically designed for operator comfort by use of high density closed cell foam, contoured back rest and arm rests. Seat is adjustable fore and aft.
<b>MOWER DECK:</b>	1 0 GA stamped steel construction 3 blades combine for 60" cut width Cut height approximately 1" to 4.5" via 8 position lift handle
<b>BLADE DRIVE:</b>	Electric clutch
<b>DRIVE SYSTEM:</b>	Each rear wheel is independently driven by a HydroGear BDU-10L Series 70 hydrostatic transmission. The hydrostatic transmissions, in turn, power a fully enclosed HydroGear gearbox.
<b>ENGINE:</b>	22 HP Kohler Command, 4-Cycle, Twin Cylinder, V-Configuration, Overhead Valve, Air-Cooled, Gasoline, Vertical Shaft, Aluminum Head and Crankcase with Cast Iron Liners, Oil Cooler.
<b>STARTING SYSTEM:</b>	Electric by key switch operation with safety interlocks on parking brake and blade drive clutch.
<b>TIRES:</b>	Front 1 1 X 4 X 5 Ribbed Tread Rear 20 X 1 1 X 8 Turf Tamer AT.
<b>RECOMMENDED TIRE PRESSURE:</b>	Front 16-21lbs. Rear 5 lbs. maximum pressure
<b>CAPACITIES:</b>	Fuel - 4.8 gallons total (dual tanks) Hydrostat oil tank - 3 quart with in-line 10 micron filter Hydrostat oil recommendation, refer to page 29 Engine - 2 qts. SAE 1 0W30 (with filter)
<b>DIMENSIONS:</b>	Width 72" Height 45" Length 89" Weight 700 lbs.
<b>NOTE:</b>	Additional information provided in service instructions under the individual component.

**SPECIFICATIONS SUBJECT TO CHANGE WITHOUT NOTICE**

---

# SEAT ADJUSTMENT INSTRUCTIONS

1. Place parking brake in ON position. (Pull brake lever up)
2. Raise and push seat assembly and upper body rearward.
3. Loosen two front seat adjustment knobs, P/N 3978, and slide seat forward or backward to desired position.
4. Re-tighten front seat adjustment knobs, P/N 3978.

*DO NOT* operate mower without seat adjustments properly tightened.

5. Carefully lower upper body and seat assembly to the closed position.

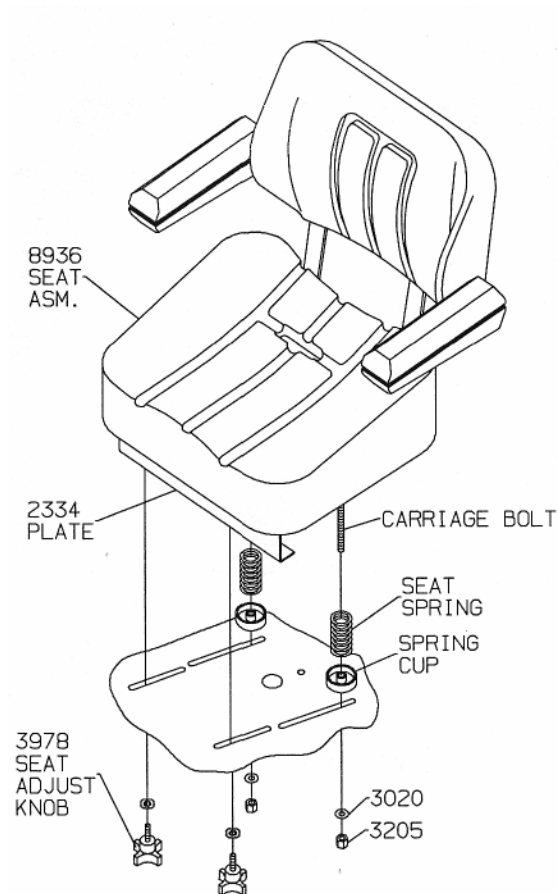

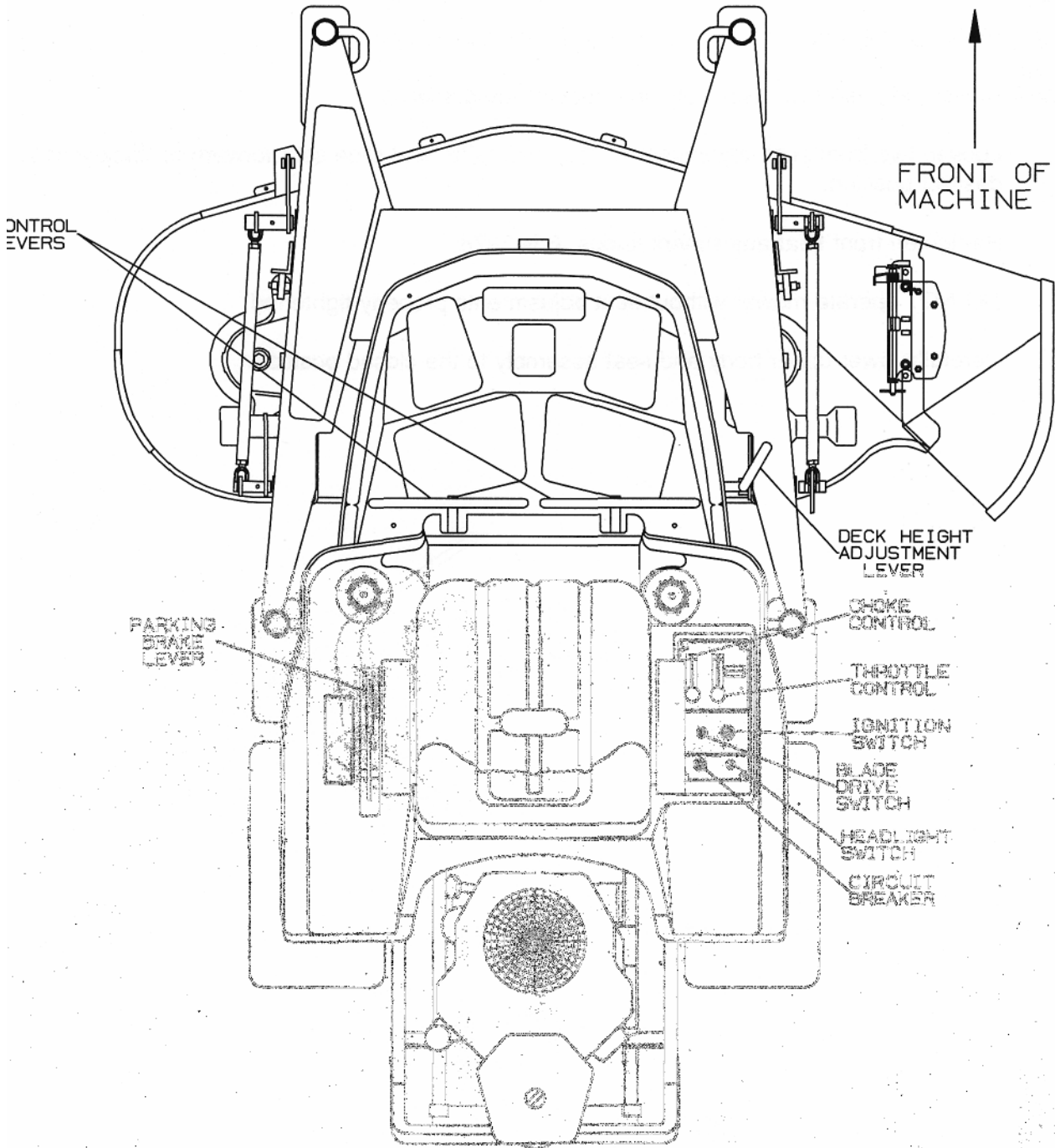

# CONTROLS

# CONTROLS

## PARKING BRAKE:

The parking brake used on the Model ZTR 6601 is designed to hold the mower from moving and is *not* intended for use in stopping the mower while it is in motion.



### CAUTION

Engage parking brake before starting engine.

Do not leave engine running for extended periods of time without the parking brake engaged. Damage to the drive system could result.

## TO SET PARKING BRAKE:

The hand operated parking brake is located at left hand side of mower.

To engage brake, pull lever up and to the rear. To release brake, move lever forward and down. **NOTE:** Always set parking brake before dismounting. Release parking brake before moving mower.

## HYDRO-GEAR DRIVE SYSTEM:

Allows the mower to turn on its own axis (zero turning radius).

Drive levers control braking, turning, travel speed and direction. Each lever controls one side of the mower.

**NOTE:** The pressure required to operate the mower is very light.

A minimum of 1/2 hour should be spent simply driving the mower without the blade drive engaged.

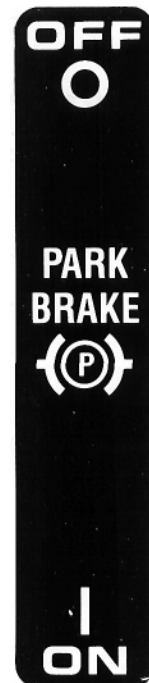

---

# CONTROLS

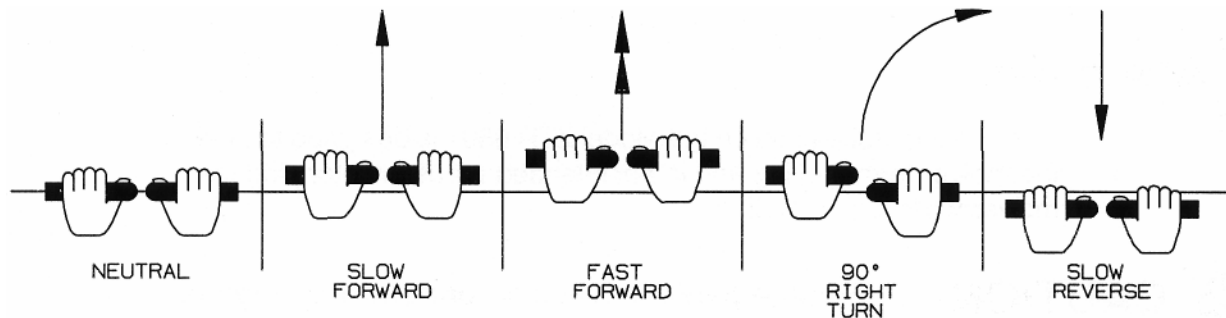

## TO GO FORWARD:

From neutral position, gently push both drive levers forward.

To increase speed, move levers farther forward.

## TO GO BACKWARD:

From neutral position, gently pull both drive levers toward you.

## TURNING:

Turning is controlled by moving one drive lever slightly forward or rearward of the other.

To turn left, move left lever rearward of the right lever.

To turn "square corners" move lever of desired direction to neutral.

To turn on mower's own axis (zero turning radius) stop and move one lever to reverse position and the other to forward position.

## BRAKING:

To brake mower, move both levers in direction opposite of travel, release levers to neutral, set parking brake. Park only on level surfaces.

## CHOKE CONTROL LEVER:

Located on control panel to operator's right.

Used to start a cold engine.

## THROTTLE CONTROL LEVER:

Located on control panel to operator's right.

Controls engine speed, slow to maximum.

While mowing throttle control should be set to the MAXIMUM or wide open setting to insure adequate cooling of the engine and to maintain mower deck blade speed.

# CONTROLS

## BLADE DRIVE:

Located on control panel, on operator's right.

To engage the mower blades, lift switch up lightly and push forward.

To disengage blades, pull switch backward. Switch is clearly marked "on and off".

## CIRCUIT BREAKER:

Located on control panel, on operator's right.

Protection of the electrical system is by (1)15 amp circuit breaker.

If circuit breaker trips, push button to reset.

If this condition repeats, consult dealer for inspection and repair.

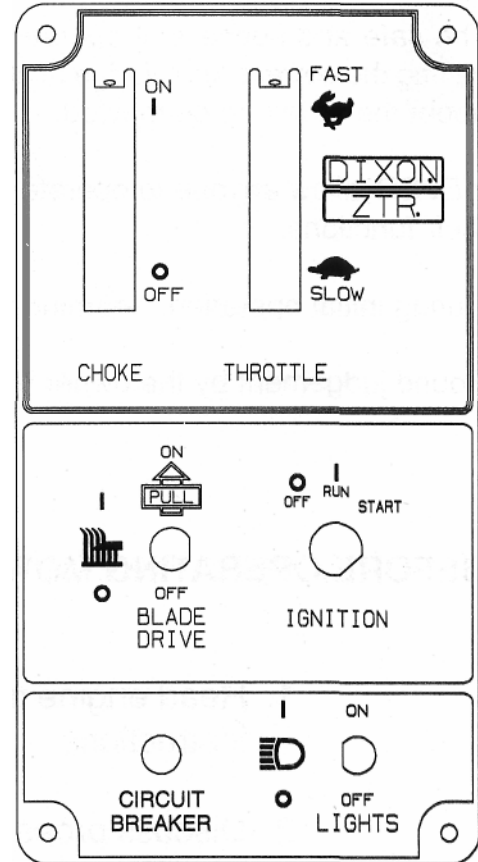

## MOWER DECK CUT HEIGHT LIFT LEVER:

Located to the right and front of operator.

Controls the cutting height.

Eight positions of adjustment.

Move lever in and forward to lower.

Move lever in and back to raise.

**NOTE:** Always use high position for transport.





---

# OPERATION INSTRUCTIONS

The safe and successful operation of the Model ZTR 6601 will depend upon the operator having the correct knowledge of all controls used on the mower and making good judgements about the terrain to be mowed.

*NEVER* allow anyone to operate the mower without complete knowledge of all controls and their functions.

During initial operation, "learning to drive", set throttle at slow speed.

Sound judgement by the owner will prevent accidents.

## **BEFORE OPERATING MOWER:**

1. Read engine manufacturer's operating and maintenance instructions.
2. Discuss proper maintenance with your dealer.
3. Read and observe all safety instructions on your mower and in the manual.
4. Check engine oil.
5. Check gas cap to be sure it is in place.
6. Be sure parking brake is on.
7. Mower blade drive is off.
8. Know how to stop engine. (Turn key to off position)

---

# OPERATION INSTRUCTIONS



## TESTING OF SAFETY INTERLOCK SYSTEMS:

**PARKING BRAKE SWITCH TEST:** With parking brake in the OFF position, engine should not turn over or attempt to start when the key switch is moved to the start position.

## BLADE DRIVE SWITCH TEST:

- a. With electric blade drive switch turned ON and parking brake in the ON position, engine should not turn over or attempt to start when key switch is moved to the start position.
- b. In a SAFE AREA away from bystanders, start the engine, place throttle setting at maximum or full. Engage the blades by turning the blade drive switch to the ON position. Raise weight slightly off of seat. *Engine should stop.*
- c. *If any Safety Check fails, do not operate the mower until the system has been checked and repaired by an Authorized Dixon ZTR Dealer.*

---

# OPERATION INSTRUCTIONS

STARTING INSTRUCTIONS: Cold Engine

1. Push choke control lever fully forward.
2. Push throttle control lever to 1/2 setting.
3. Insert ignition key and turn to "Start" position. When engine starts, release ignition key. Key will return to "Run" position.
4. Once engine starts to *warm up*, slowly move choke control lever to the fully closed position.
5. Move throttle control lever to the *wide open or maximum* setting for actual operation of the mower deck.
6. Engine must be operated at *wide open or maximum* setting to insure adequate lubrication, cooling and cut quality of the mower deck.

**NOTE:** Model ZTR 6601 will require a slightly longer warm up period using partial choke settings.

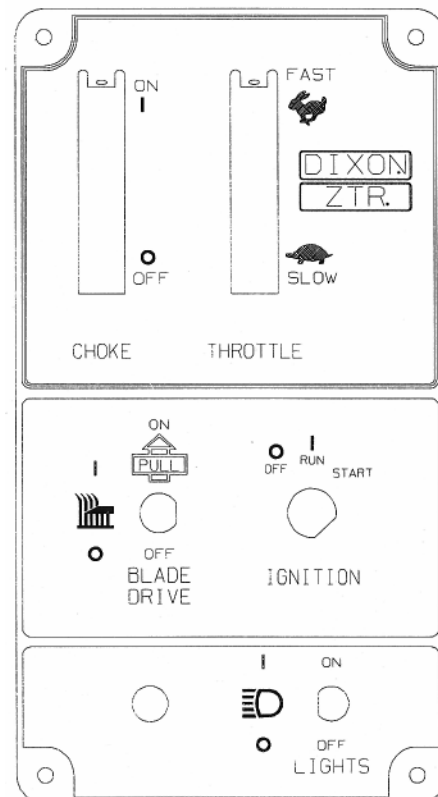

---

# OPERATION INSTRUCTIONS

**STARTING INSTRUCTIONS:**    **Engine has been operated.**

- 1 . Move throttle control lever to 1/4 to 1/2 setting.
2. Insert ignition key and turn to "Start" position. When engine starts, release ignition key. Key will return to "Run" position.
3. Move throttle control lever to *wide open or maximum* setting for actual operation of the mower deck.

NOTE:        Model ZTR 6601 may require partial choke setting to start even if the engine has been operated for a period of time.

4. Engine must be operated at *wide open or maximum* setting to insure adequate lubrication, cooling and cut quality of the mower deck.



**DO NOT operate the engine in an enclosed area due to the harmful exhaust gas produced.**

NOTE:        On initial operation, set throttle at slow speed.

Engine cannot be restarted when blade is engaged.

Safety switches stop engine when operator leaves seat while mower blade is engaged.

*Always turn engine off when leaving mower.*

---

# OPERATION INSTRUCTIONS

In order to achieve optimum cutting performance, please read and follow the tips listed below.

Additional information can be found in the troubleshooting guide on page 35.



## CAUTION

Be sure that deflector is properly installed on the discharge chute.

- 1 Set engine speed control to the wide open or full setting.
- 2 *Do Not Attempt To Cut Grass When It Is Wet.* Wet grass will clog the underside of the deck and discharge area.
- 3 If the grass is tall, place the mower deck cut height lever in the top or second notch. "Initially" overlap cutting swaths instead of a full swath with each pass. Some applications may require a second cutting.
- 4 *Keep The Underside Of The Mower Deck Clean.* Frequent removal of dried grass and dirt will allow the clippings to discharge correctly.
- 5 *Maintain Sharp Blade(s) Throughout The Cutting Season.*

## GRASS HEIGHT SUGGESTIONS:

*Correct mowing height can reduce weeds and disease by 50% to 80%*

The following grass cut heights are based on adequate moisture conditions and normal thatch buildup in a healthy lawn. Some locations and applications may require slightly different cut heights. If in doubt, consult your local lawn professional for assistance.

Grass Types:	Best Cut Heights:
Zoysia	2" - 2 1/2"
Blue Grass	1 1/2" - 3"
Fescue Blends	1 1/2" - 3"
St. Augustine (Mid South)	1 1/2" - 2"
St. Augustine (Deep South)	3" - 4"
Tifton Bermuda	1 1/2"
Centipede	1 1/2" - 2"
Common Bermuda	1 1/2" - 2"
Bahia/Argentina/Pensacola	2"

---

# CARE AND MAINTENANCE

This portion of the Model ZTR 6601 owners manual deals with normal service items which can be performed by the owner. Please remember that if you are in doubt as to the correct service procedures to be followed, these and other service situations can be handled by a Dixon ZTR dealer who is familiar with the service of your mower.

## MAINTENANCE SCHEDULE:

To insure a long and trouble free service life on all the components used on the Model ZTR 6601 a regular and thorough maintenance schedule should be followed. The following items should be checked after the first (10) hours of operation and on a weekly basis, or each (40) hours of use: (Items marked with an asterisk \* require more frequent attention)

1. Drive system, belts and controls.
2. Mower deck belts.
3. Tire pressures.
4. HydroGear oil tank.
5. Tightness of all nuts and bolts.
6. Battery fluid level.
7. \* Engine oil. (Before each use or every 8 hours)
8. Electric blade clutch air gap setting.



## CAUTION

**Before performing any maintenance,  
shut off engine, allow to cool.**

**ENGINE:** For engine operating and maintenance information, refer to the engine operating and maintenance instructions furnished by the engine manufacturer, supplied with each mower.

**BATTERY:** Check the fluid in the battery at frequent intervals.  
Keep fluid level above the plates in each cell, using distilled water.

### OFF-SEASON BATTERY STORAGE:

Identify each cable so cables can be reconnected to correct terminals.

Disconnect cables from terminals.

ALWAYS disconnect ground cable first and reconnect last.

Charge battery.

DO NOT remove battery from mower.

Clean top of battery and terminals with baking soda and water.

---

# CARE AND MAINTENANCE

## CUTTER BLADE MAINTENANCE:

**NOTE:** Observe proper blade position prior to removal.

1. Safely raise front of mower.
2. Hold or block blade from turning.

### CAUTION

Wear heavy, thick gloves when holding onto cutter blade, avoid the sharp edge of the blade.

**NOTE:** Be sure blade is centered on pilot before tightening bolt to 60 ft. lbs. torque.

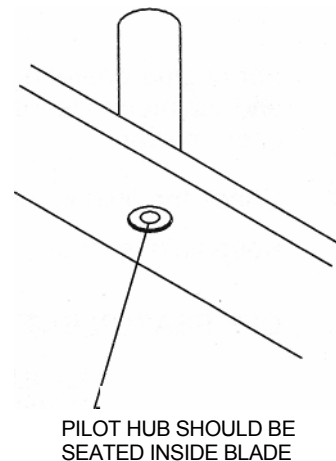
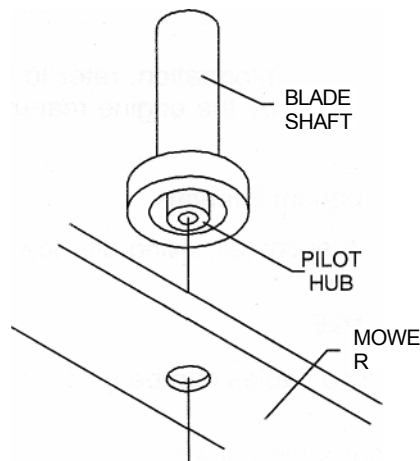

---

# CARE AND MAINTENANCE

## BELT TENSION

### ENGINE TO MOWER DECK BELT: P/N 9758

No adjustment required.

Correct belt tension is maintained through a fixed engine location and a spring loaded idler system.

A pulsing movement of the belt idler will be observed both during engagement of the electric blade clutch and actual operation of the mower deck.

**NOTE:** Engagement of the electric blade clutch switch may produce a sharp high pitched chirp or squeal as the belt tension loading is absorbed by the idler system. This is normal and not a sign of failure.

### MOWER DECK SERPENTINE BELT: P/N 6939

Refer to illustration for adjustment procedure.

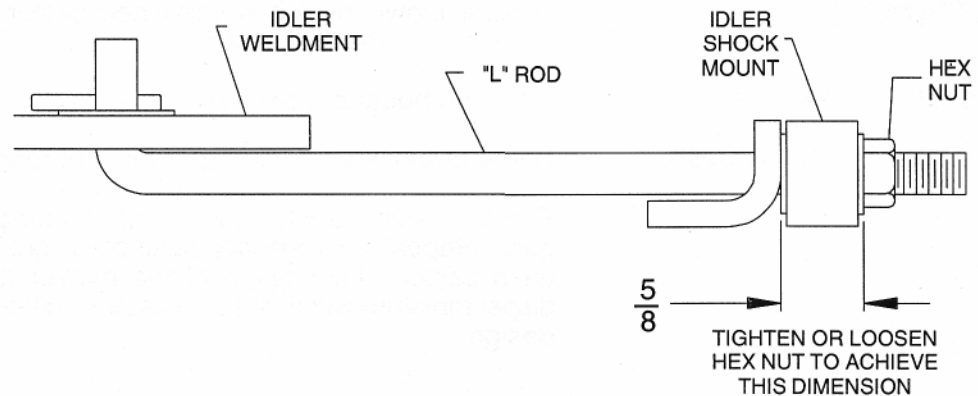

**NOTE:** Belt deflection or movement should be approximately 1/4" when measured at mid-point between pulleys.

Periodically inspect both belt and idler systems.



---

# CARE AND MAINTENANCE

## FUEL SHUT OFF VALVE:

A fuel shut off valve is located at the bottom rear of each fuel tank.

*Always* turn the valve to the "OFF" position when the mower is stored or not in use.

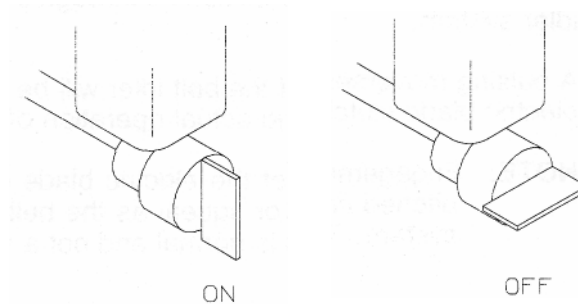

## LUBRICATION

CHASSIS:

Number of grease zerks used: (11)

LOCATIONS:

(1) each mower deck carriage wheel caster and each wheel hub  
(1) each mower deck shaft

SERVICE INTERVALS:

Every 50 hours of operation

RECOMMENDED GREASE:

Name brand wheel bearing or multi-purpose grease

Rotate or spin each front wheel after 3 full pumps of the grease gun. Repeat until the appearance of grease is noted around each caster. Lubrication of the mower deck shafts will help dispel moisture within the hub casting. Bearings are of a sealed design.

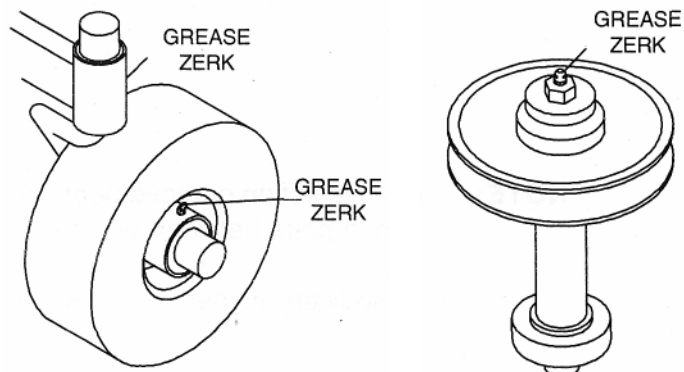

---

# CARE AND MAINTENANCE

## REAR WHEELS:

The rear wheels of the Model ZTR 6601 are of an "offset" center design to both compliment the articulation of the mowing deck and to provide stability when mowing on sloped ground.

## CAUTION

**Slopes are a major factor related to loss-of-control and tip-over accidents, which can result in severe injury or death. All slopes require extra caution. If you cannot back up the slope or if you feel uneasy on it, do not mow it.**

### REAR TIRES:

Tread Design:	Soft compound, low air pressure, "Turf Tamer" all terrain tires have been fitted to the Model ZTR 6601.
Shipping Air Pressure:	For crating and shipment purposes "ONLY" air pressure has been increased to 15 lbs.
Operational Air Pressure:	Prior to actual operational use of the mower, the air pressure in each rear tire must be lowered to a maximum of 5 lbs.

---

# CARE AND MAINTENANCE

## LUBRICATION

### DRIVE SYSTEM:

The gears in the HydroGear gearbox are permanently lubricated using a special grease which completely eliminates the need for any type of maintenance.

The HydroGear BDU-10L Series 70 hydrostatic transmissions are serviced with any high quality 10W30 motor oil. The oil is filtered by a 10 micron oil filter. Recommended service interval for filter is after the first 250 hours of operation, then after every 400 hours of operation. If the system becomes contaminated by dirt of other foreign debris, both oil and filter must be replaced immediately.

**IMPORTANT:**        *Protect your investment:*

Use Dixon P/N 5565 hydrostatic transmission oil filter ONLY.

The use of generic filters on the hydrostatic transmission oil system is *not* recommended. While any number of automotive filters may fit the thread pattern on the filter head, these filters contain high pressure relief valves which will not permit oil flow to the transmissions. This will result in an *air /oc/c*with possible damage.

---

## CARE AND MAINTENANCE

### CAUTION

**HOT oil may cause burns.  
Allow engine to cool before draining oil.**

#### CHANGING THE ENGINE OIL:

1. The "snap lock" oil drain valve is located on the left side of the engine crankcase.
2. Place a suitable container under the drain valve. The fitting of a short piece of hose to the valve will help direct the oil.
3. *Push* the valve body in and *twist* to clear the detent notch.
4. *Pulling* the valve body outward will start the flow of oil.

**NOTE:** Refer to engine manufacturers recommendations for frequency of oil changes.

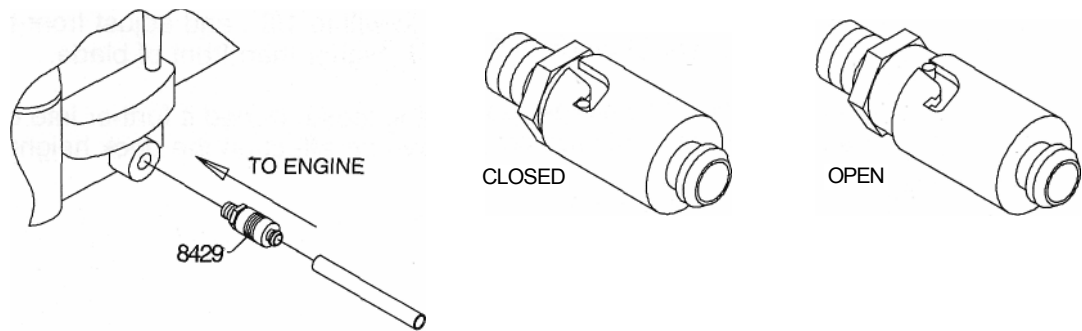

#### OIL FILL:

1. Push the valve body in and twist into the detent notch.
2. Clean any spilled oil from engine and chassis.
3. Refill engine with type, and quantity of oil recommended by the engine manufacturer in engine literature.

**NOTE:** Engine oil changes on the Model ZTR 6601 will require replacement of the oil filter. These filters can be obtained from any authorized Kohler engine dealer.

#### PROTECT YOUR INVESTMENT:

The use of non-original oil or air filters may result in damage to the engine and a loss of warranty. Listed on page 34 are the correct Kohler part numbers for the Model ZTR 6601 engine.

**PLEASE DISPOSE OF USED OILS AT PROPER COLLECTION CENTERS  
PROTECT YOUR ENVIRONMENT**

# CARE AND MAINTENANCE

## DECK LEVELING AND HEIGHT ADJUSTING PROCEDURE

1. *On the right side of the machine*<sup>^</sup> the tie bar between the lift arms should be adjusted so there is 20-1/2" between clevis eyes. If adjustment is necessary, loosen jam nuts on both ends of the bar, and turn bar by hand until 20-1/2" dimension is achieved. Tighten jam nuts securely back against both ends of the bar.

*On the left side of the machine*, the tie bar should be adjusted so the angle of the rear lift arm matches the angle of the right rear lift arm. If adjustment is necessary, loosen jam nuts on both ends of the bar, and turn bar by hand until angle of the two rear lift arms match. Tighten jam nuts securely back against both ends of bar. See Figure 1.

2. Move lift handle to mid-range and use blade height gage (8241) to check side-to-side and front-to-rear blade heights.
3. Adjust side-to-side blade heights to within 1/8", and adjust front-to-rear blade heights so rear of blade is 0 to 1/4" higher than front of blade.
4. If any of the deck hanger bolts hang loose, thread it further into clevis until it is snug. Take special care not to have an effect on the deck height.
5. Tighten jam nuts up against clevis.

Figure 1

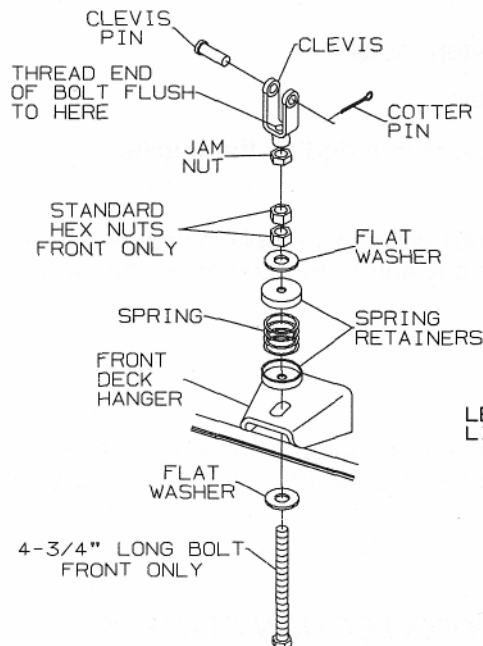
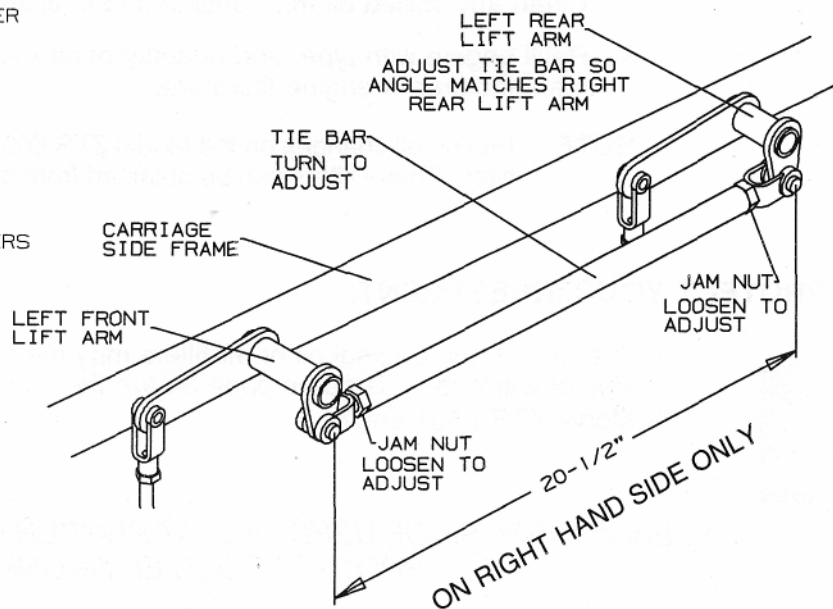

Figure 2



---

# CARE AND MAINTENANCE

## DRIVE SYSTEM ADJUSTMENTS:

Adjustment of the drive system is limited to the actual function of the hydrostatic transmissions as outlined below.

## T-BOX TO HYDROSTAT BELT ADJUSTMENT:

Tighten the (2) J-bolts on the T-box mounting plate until each belt has 1/8th to 1/4th of an inch free play or movement at a mid-point between the pulleys on the hydrostats and T-box.

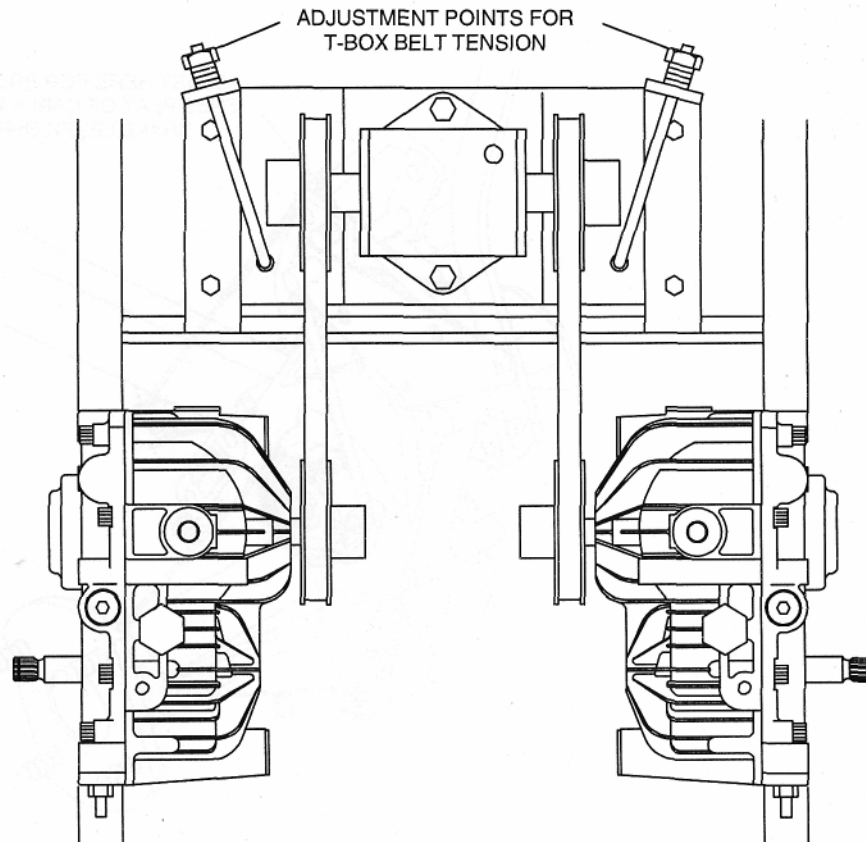

---

## CARE AND MAINTENANCE

### PARKING BRAKE CABLE ADJUSTMENT:

Position parking brake lever in the off or disengaged position.

This will allow the belt idler used on the engine to T-box to swing fully and apply tension to the belt.

At this time, check that the cable which pulls the idler to a neutral position has approximately 1-1/2 to 2 inches of free play.

If adjustment is required, loosen the lock nuts on the cable block and turn cable sleeve in or out to achieve desired measurement.

Re-tighten lock nuts.

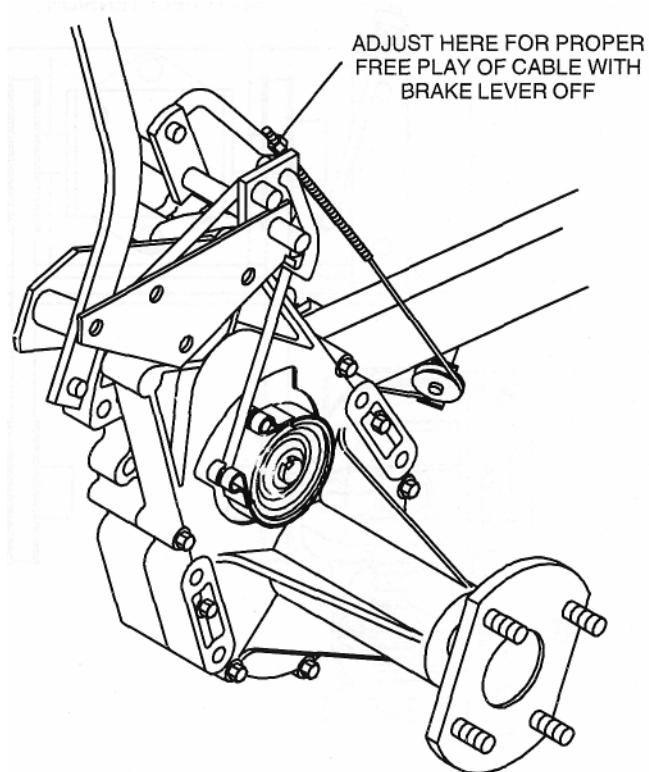

**NOTE:** Cable must have the above dimension with parking brake released or drive belt may slip, causing loss of power.

---

## CARE AND MAINTENANCE

### NEUTRAL ADJUSTMENT:

Swing upper control levers out into the neutral slots.

Raise upper body to the fully open position. Start engine and disengage parking brake.

Caution should be used when releasing parking brake as mower may tend to creep or move prior to adjustment.

If adjustment is required, loosen lock nuts at each end of the control rods and back off the tension on each spring block.

Turn control rods in or out until neutral is obtained on each hydrostat.

Re-tighten lock nuts and tension bolts on spring blocks.

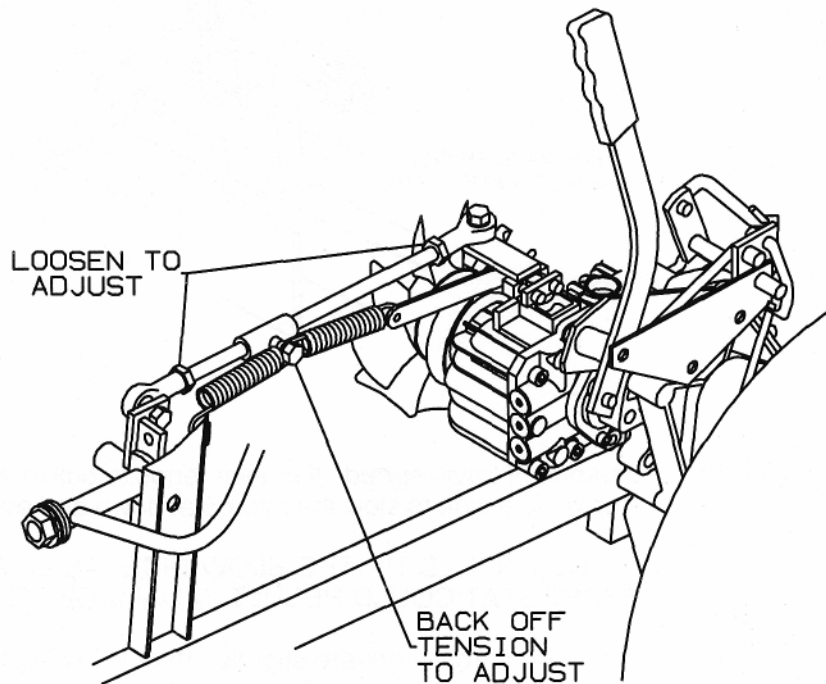



---

# CARE AND MAINTENANCE

## FORWARD TRAVEL SPEED ADJUSTMENTS:

Stop engine, move levers to drive position, lightly push each upper control lever forward until a resistance is felt on the lever.

At this time, check that the forward lever stops on the bottom of each lever are hitting the stop blocks.

If adjustment is required, loosen the lock nuts on the lever stop and turn the bolt in until the lever hits the stop block before resistance is felt in the hydrostat.

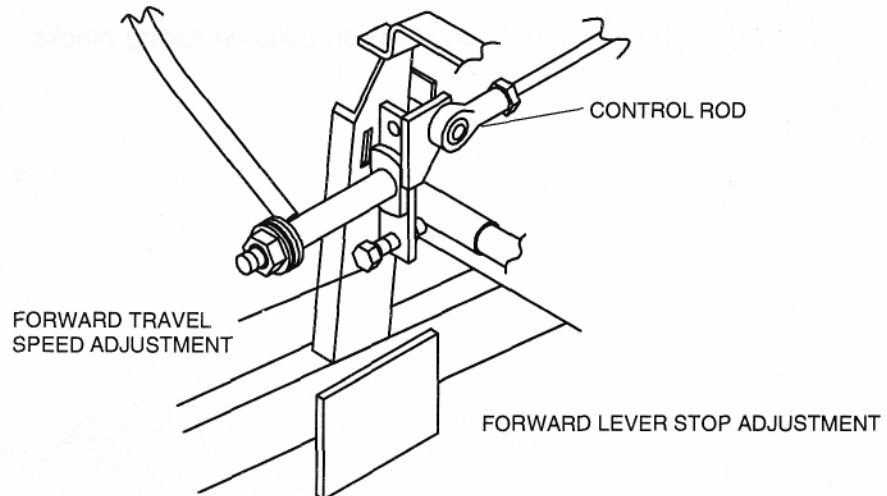

**NOTE:** Balance of travel speed. If mower tends to pull to either side, re-adjust lever stop on fast side to slow the hydrostat down and even out the ground speed.

DO NOT SPEED UP THE SLOW SIDE, AS OVER STROKING OF THE HYDROSTAT COULD RESULT IN DAMAGE TO THE UNIT.

If upper control levers are slightly offset following this adjustment, they can be realigned by bending them slightly.

# CARE AND MAINTENANCE

## PROCEDURE FOR ELECTRIC CLUTCH ADJUSTMENT

Electric clutches require periodic Air Gap adjustments to extend the life of the clutch. Listed below is both an Air Gap adjustment procedure and an Ohms test to check for a faulty coil within the clutch. No replacement parts are available to repair a faulty assembly. The entire clutch must be replaced.

### A. AIR GAP ADJUSTMENT

1. Remove the clutch from the engine. This is recommended because it is easier to verify the gap.
2. Locate the three rivet joints which fasten the leaf springs to the armature, (figure 1)
3. Rotate the pulley until these rivet joints are located midway along the edge of the triangular field adapter, (figure 1)
4. Locate the three holes in the brake plate, one near each adjustment nut. (figure 2)

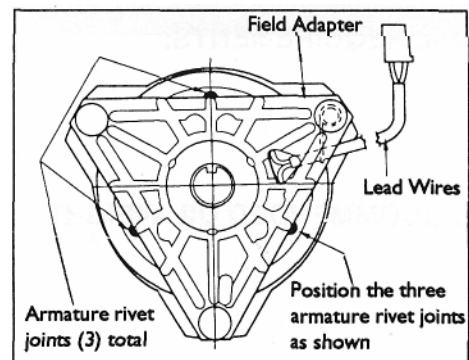

figure 1

5. Insert a .012 inch feeler gauge into one of the three windows. Be careful to position the feeler gauge between the rotor and armature faces, (figure 3)
6. Tighten the adjusting nut adjacent to the window with the feeler gauge inserted until the gauge fits snugly between the rotor and armature. The gap should not be so tight that the feeler gauge cannot be reinserted after removal.
7. Repeat Steps 5 and 6 at the other two windows.
8. Re-check the air gap at each window and make minor adjustments as necessary to achieve a consistent .012 inch air gap.
9. Reinstall the clutch to the engine. Be sure to torque the mounting bolt back to 50 ft. lbs.

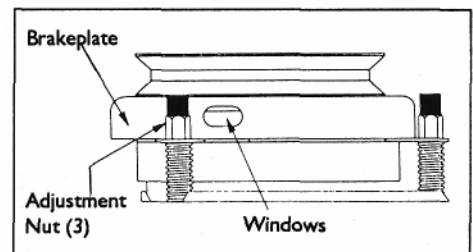

figure 2

### B. OHMS TEST:

1. Disconnect clutch from mower wiring harness which is located on the right side of the mower frame.
2. Set the multi-meter on RX1 and attach the two leads to the two wires coming from the electric clutch.
3. The reading you receive should be between 2.4 to 2.9 OHMS.
4. If the resistance is outside this range the clutch coil is faulty.
5. If the clutch coil is faulty, the clutch must be replaced.

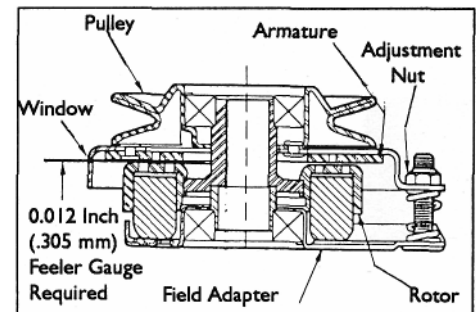

figure 3

---

# CARE AND MAINTENANCE

## HYDROSTATIC TRANSMISSION OIL AND FILTER SERVICE

**SERVICE INTERVALS:**

1. Initial oil and filter service - 50 hours.
2. Every 250 hours thereafter.

**OIL REQUIREMENTS:** Any high quality engine oil with an API classification of SG/CD is recommended.

**RECOMMENDED OIL WEIGHT:** 10 W30  
Another alternative that will provide excellent all climate performance and extended time between oil changes is a 15 W 50 synthetic engine oil.

**OIL FILTER:** P/N 5565 - IMPORTANT

The oil filter is a special 10 micron design for use on "vacuum or suction" oil flow systems.

**DO NOT:** Use automotive engine oil filters. These filters require a "pressure" to allow oil flow. Usage will result in an "air-lock" condition with possible damage.

---

## CARE AND MAINTENANCE

WHEELS AND TIRES: Correct tire pressure is important for correct operation of mower.

Front Tires	1 1 X 4 X 5	Air Pressure	16-21 lbs.
Rear Tires	20 X 11 X 8	Air Pressure	5 lbs. (maximum pressure)

NOTE: Check lug nuts periodically for tightness.

ELECTRICAL SYSTEMS: Keep all connections clean and tight.

CLEANING THE MOWER: Wash mower periodically.

Clean above and below deck.

NOTE: Allow mower to cool before washing. If bearings are hot, they will draw moisture inside as they dry and cause corrosion.

SERIAL NUMBERS: The serial number is located on frame at rear of engine, it will begin with DM.

WARRANTY: Refer to Warranty Registration Form (P/N 8289).

PARTS/SERVICE: See your Dixon dealer for replacement parts, warranty or service.

***PLEASE HELP PROTECT THE ENVIRONMENT BY AVOIDING ALL CHEMICALS WHICH MAY DAMAGE OR CAUSE HARM TO PLANTS AND ANIMALS IN YOUR AREA***

---

## STANDARD SERVICE PARTS LIST

### MODEL ZTR 6601:

BLADES:	Hi-Lift:	P/N 9383
Engine To Mower Deck:	Serpentine Belt:	P/N 9758
Engine To T-Box:	T-Box To Hydros:	P/N 6939
		P/N 1714
		P/N 1765
Hydrostatic Transmission Filter:		P/N 5565

### KOHLER AIR AND OIL FILTER PART NUMBERS:

Refer to engine manufacturers manual for recommendations regarding frequency of service required for engine oil changes and air filter maintenance.

*Protect* your engine investment, use only original equipment filters.

Model ZTR 6601:	22HP	Pre-Cleaner Foam Element	45083-01
		Cartridge Air Cleaner	45083-02
		Engine Oil Filter	12050-01

### IMPORTANT:

Some applications, extreme dirt conditions, or the use of a grass catcher may require that the engine used on the Model ZTR 6601 be fitted with an *OPTIONAL Kohler fresh air filter system*.

Listed below are the Kohler kit numbers required to adapt these components to the engine. Consult your dealer or a Kohler engine service center for additional information.

Model ZTR 6601:	22HP	Check with Kohler Dealer for availability
-----------------	------	---

---

## TROUBLESHOOTING

### MOWER CUT QUALITY:

There are many variables that can effect the cut quality of any riding mower. Type and conditions of grass, cut height setting, engine RPM and ground speed are some of the variables that interact creating differences in cut quality. Examination of one or more of the above will generally produce a quality cut.

The Troubleshooting Chart suggests practices and adjustments that may be helpful in improving cut quality. Your Dixon ZTR dealer is also available to provide assistance to you.

<u>SITUATION</u>	<u>CAUSES</u>	<u>REMEDY</u>
Poor cut quality	Ground speed	Reduce mowing speed
Poor cut quality	Incorrect engine to mower deck belt	Refer to page 34 for part numbers
Poor cut quality	Engine RPM too low	Increase engine RPM to maximum
Poor cut quality	Dull or bent blade	Sharpen or replace as required
Poor cut quality	Un-level mower deck	Consult your dealer
Poor cut quality	Grass buildup under mower deck	Clean out underside of mower deck
Poor cut quality	Improper blades	Replace with original equipment blade designed for the Model ZTR 6601
Poor cut quality	Uneven tire pressures	Check and adjust as required per operators manual

---

## TROUBLESHOOTING

### DRIVE SYSTEM:

SITUATION	CAUSES	REMEDY
Mower pulls to one side or the other	Drive adjustment	Consult your dealer for repair
Drive system will not function on either side after changing hydrostatic transmission oil and filter	Incorrect oil filter installed on system Hydrostatic transmissions are "air locked", low or no oil return to tank	Replace with correct Dixon P/N 5565 filter Consult your dealer for repairs Continued attempted operation may result in damage to the system
Drive system functions on one side only	Loss of set screw tension on hydrostatic transmission pulley	Consult your dealer for repairs
Loss of power and speed on both hydrostatic transmissions	Incorrect parking brake cable adjustment Incorrect or worn drive belt	Refer to adjustment procedure page 28. Replace with correct belt

---

---

# TROUBLESHOOTING

## ELECTRICAL SYSTEM:

SITUATION	CAUSES	REMEDY
Starter will not turn engine over	Circuit breaker engaged	Push button to reset Consult your dealer for repair
Starter will not turn engine over	Dead battery	Charge battery
Battery discharge	Poor connections on battery Battery water low Wrong battery installed in mower	Tighten or replace as required
Battery discharge	Engine electrical system not functioning correctly	Have electrical system checked by your dealer
Battery discharge	Engine being operated at too low an RPM	Increase engine RPM Contact your dealer for information

---

**NOTE:** Electrical system failures are generally simple in nature, always check the obvious first and then move onto the more complicated parts used. Poor battery service, loose connections, corrosion, frayed or broken wiring, are more likely than component failure.



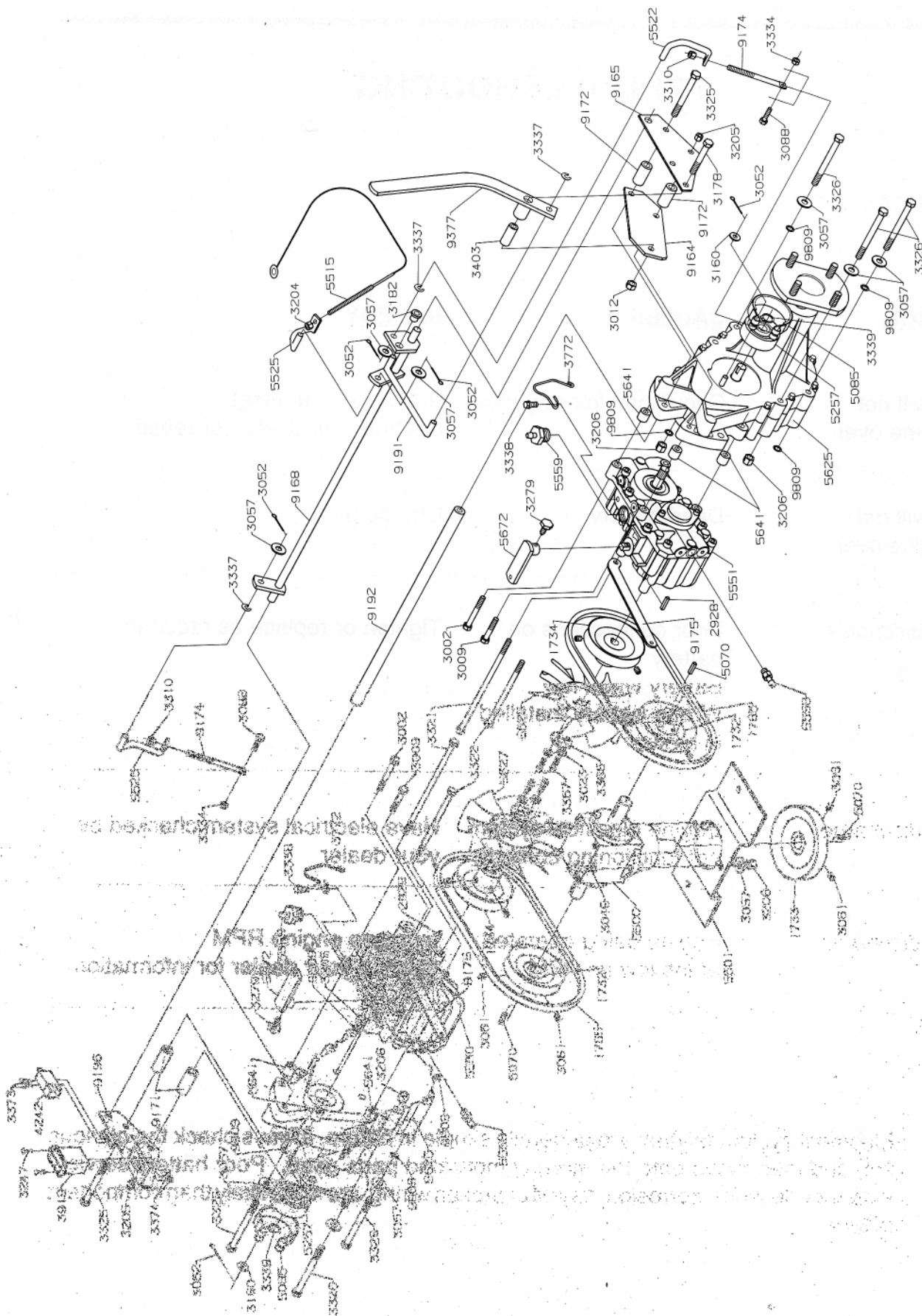

601 T-Box/Hydro/Gearbox

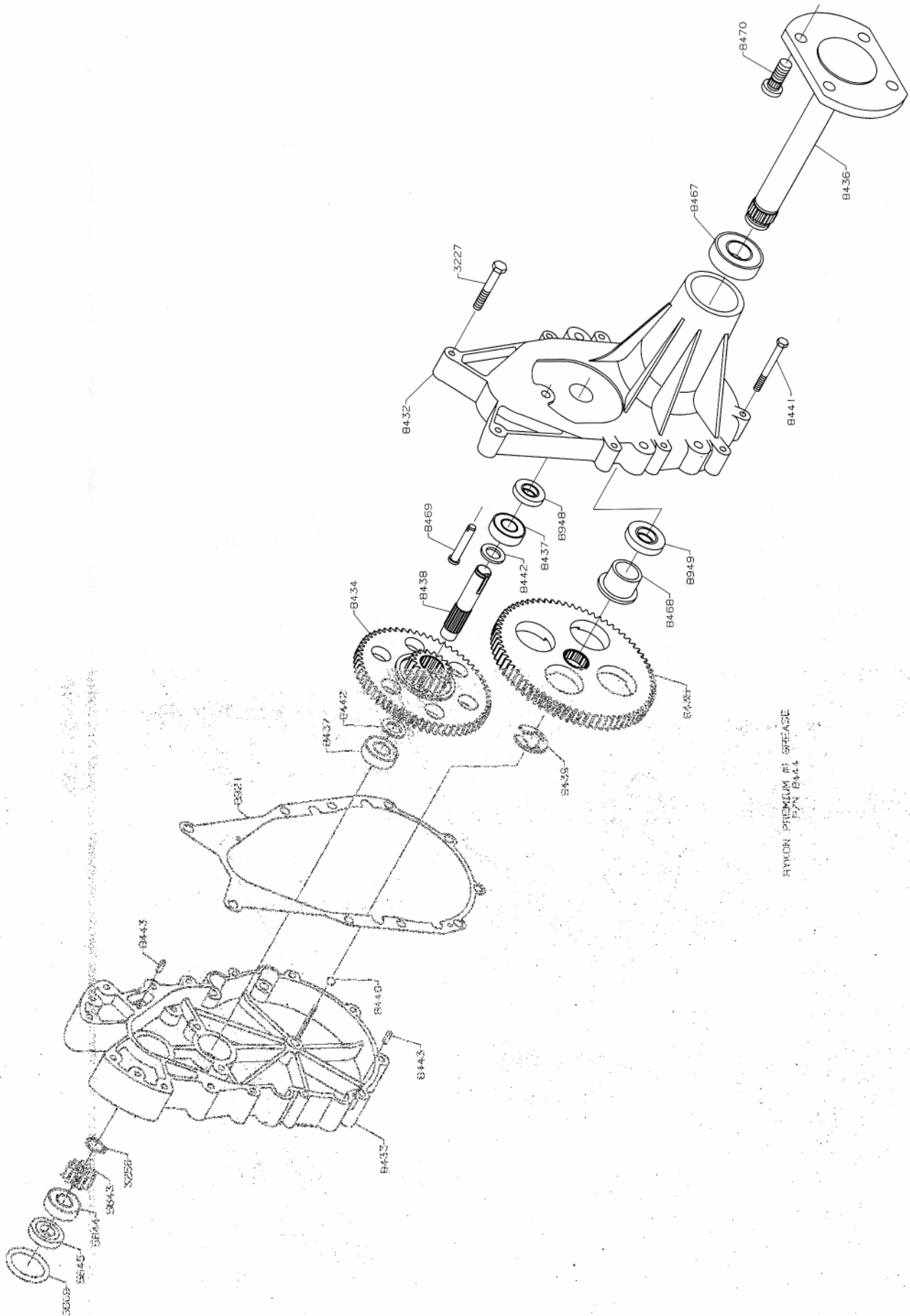

HYKON PREMIUM #1 GREASE  
P/N B444

## 6501 Gearbox

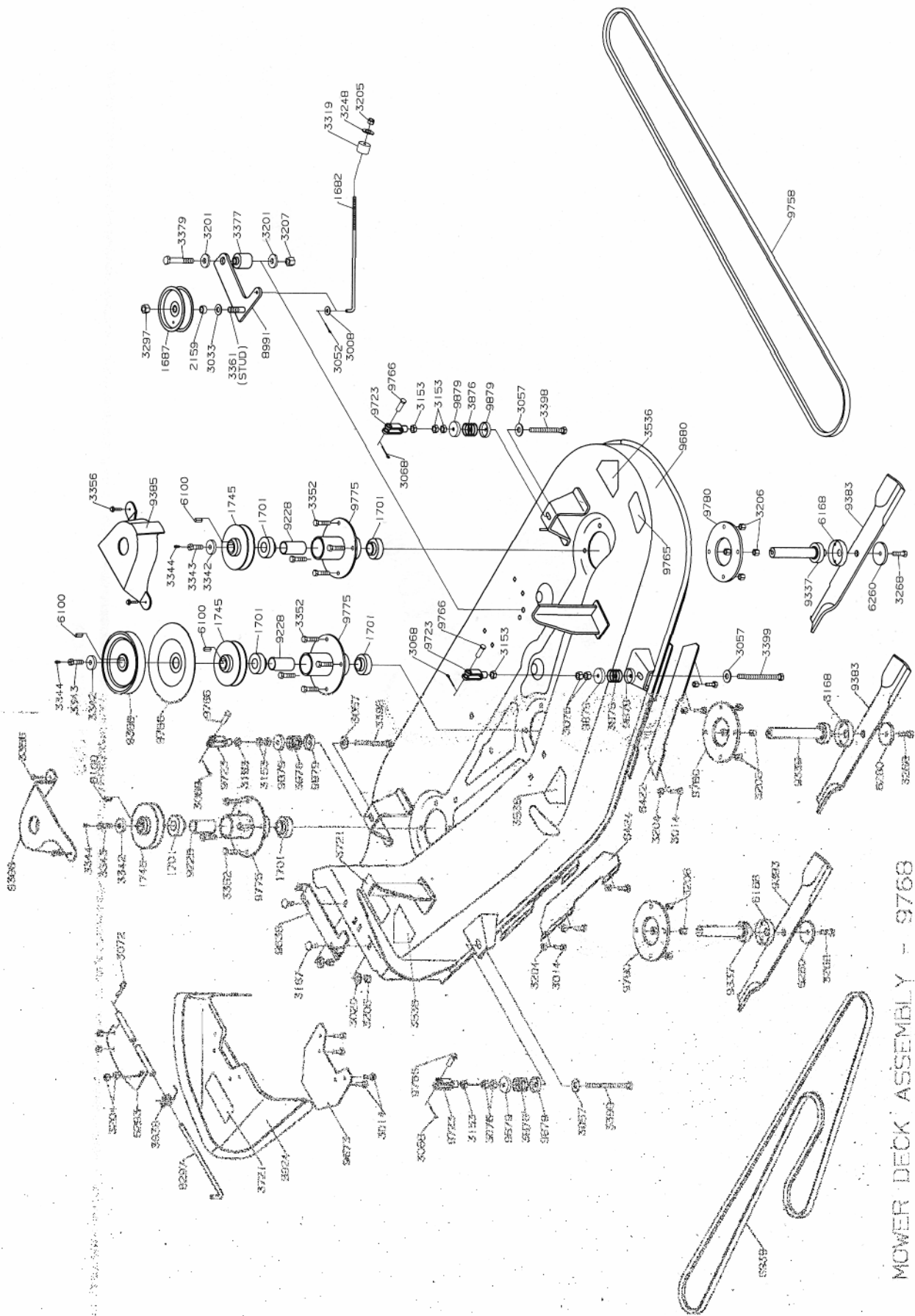

MOWER DECK ASSEMBLY - 9768

6601 Mower Deck

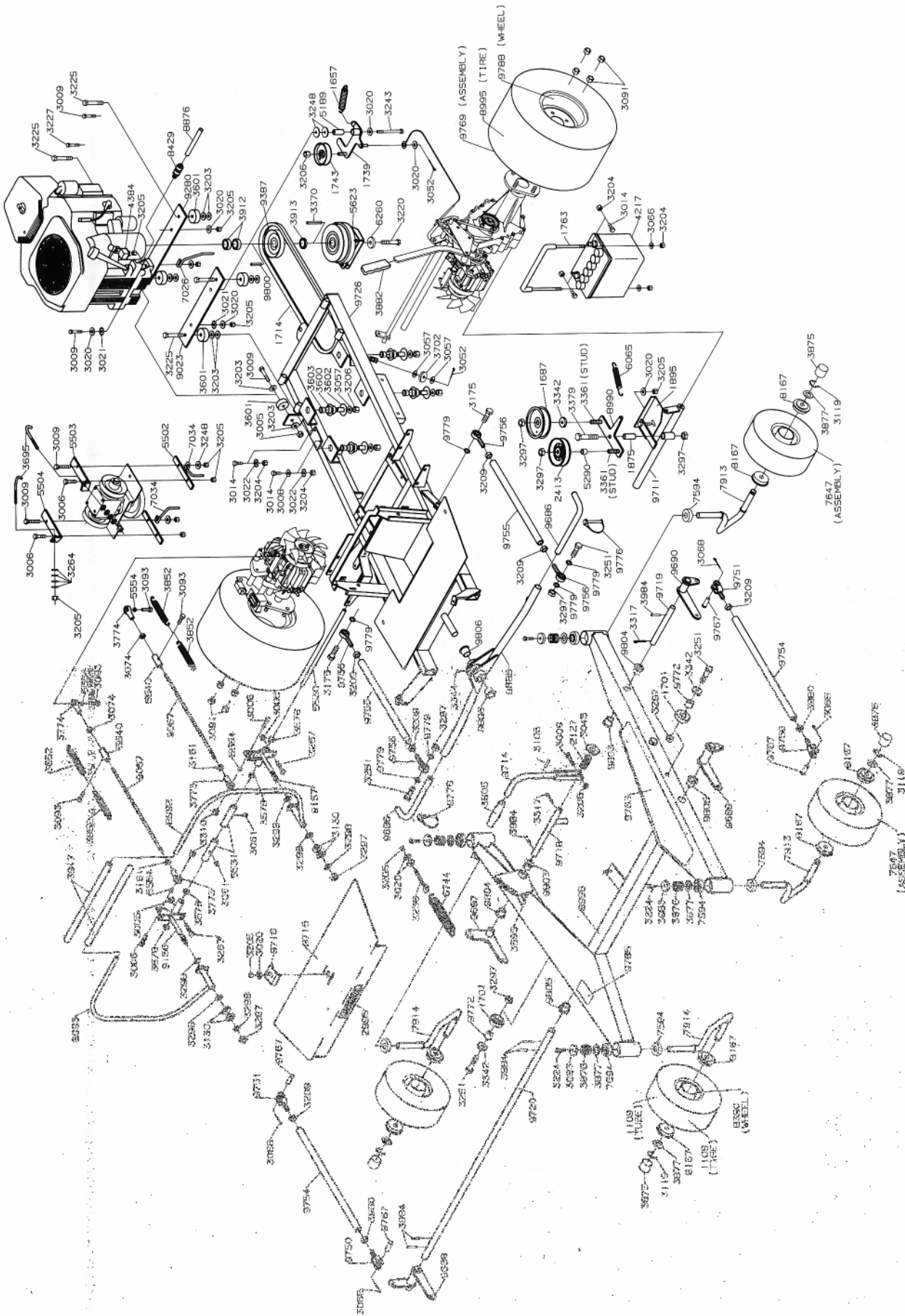

**6601 Chassis**



SEAT ASSEMBLY - 8936

ALL ITEMS SHOWN ARE INCLUDED IN HARDWARE PACKAGE B411

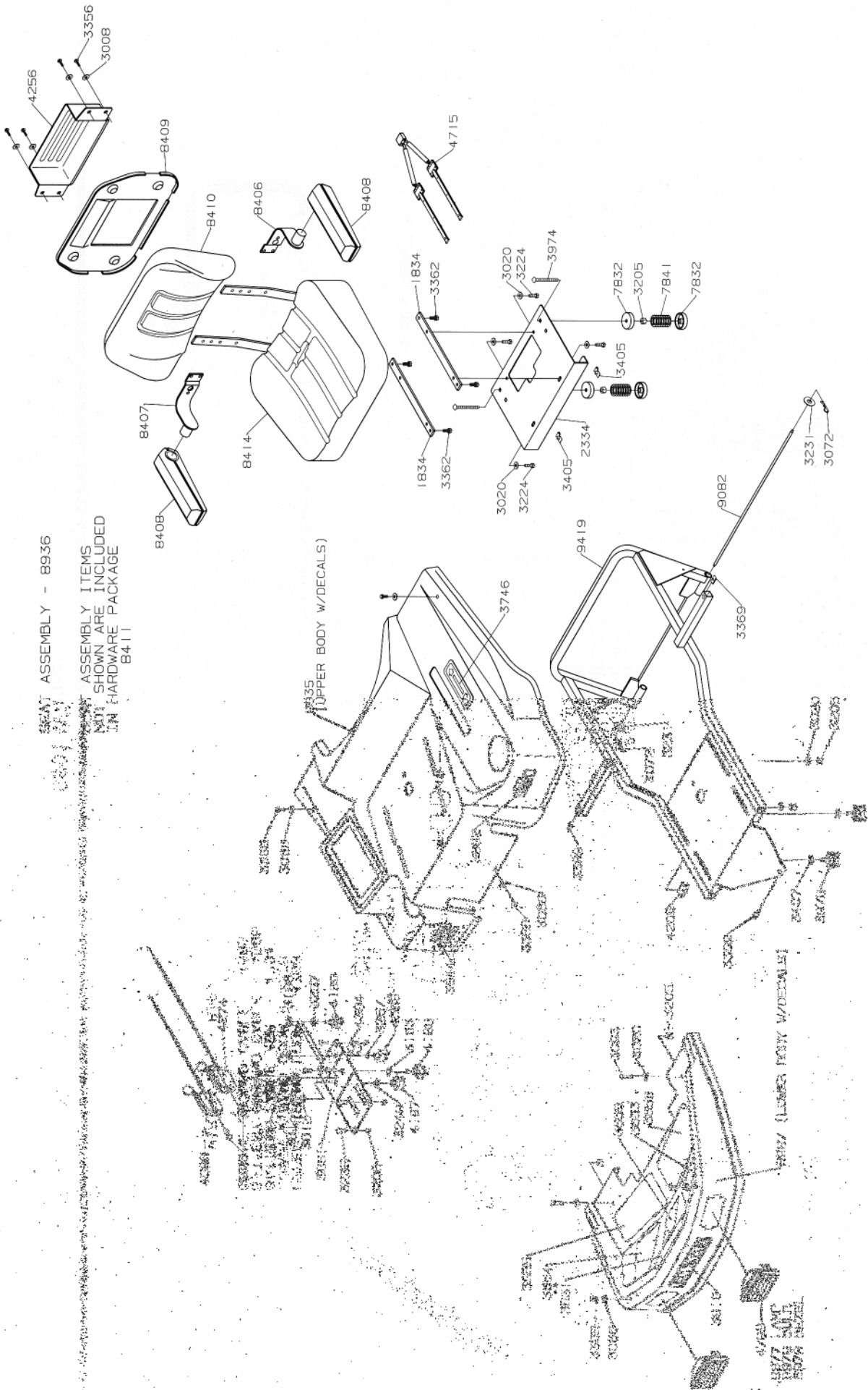

8936 Body



# NOTES

---





DIXON INDUSTRIES, INC  
A BLOUNT COMPANY  
AIRPORT INDUSTRIAL PARK  
PO BOX 1569  
COFFEYVILLE KS 67337 0945  
316 251 2000  
FAX 316 251 4117



# OWNER INFORMATION

DATE PURCHASED \_\_\_\_\_ MOWER MODEL NUMBER \_\_\_\_\_

PURCHASED FROM \_\_\_\_\_  
Name \_\_\_\_\_  
Address \_\_\_\_\_  
\_\_\_\_\_

MOWER SERIAL NUMBER **DM-** \_\_\_\_\_

DATE OIL CHANGED:	DATE ENGINE TUNED:
_____	_____
_____	_____
_____	_____
_____	_____
_____	_____
_____	_____
_____	_____
_____	_____



ZTR Riding Mowers

 **WARNING:** The Engine Exhaust from this product contains chemicals known to the state of California to cause cancer, birth defects or other reproductive harm.

® Dixon and ZTR are registered trademarks of Dixon Industries, Inc.

DIXON INDUSTRIES, INC.  
A BLOUNT COMPANY  
AIRPORT INDUSTRIAL PARK  
PO BOX 1569  
COFFEYVILLE KS 673370945  
3162512000 FAX 316 251  
4117

**Part No. 8946**  
September 1995

## Free Manuals Download Website

<http://myh66.com>

<http://usermanuals.us>

<http://www.somanuals.com>

<http://www.4manuals.cc>

<http://www.manual-lib.com>

<http://www.404manual.com>

<http://www.luxmanual.com>

<http://aubethermostatmanual.com>

Golf course search by state

<http://golfingnear.com>

Email search by domain

<http://emailbydomain.com>

Auto manuals search

<http://auto.somanuals.com>

TV manuals search

<http://tv.somanuals.com>