

# DIXON ZTR®

## Operator's Manual

Ram Xs5025 / 968999722

Ram Xs6025 / 968999723

Ram Xs7227 / 968999724

Ram Xs5025BF / 968999725

Ram Xs6025BF / 968999726

Please read the operator's manual carefully and make sure you understand the instructions before using the machine.

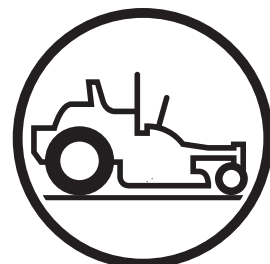

**English**

©2007 HTC. All rights reserved.  
Beatrice, NE. Printed in U.S.A.

# CONTENTS

INTRODUCTION.....	5	Engine Cooling Air Intake .....	38
General.....	5	Throttle Cable .....	38
Driving and Transport on Public Roads .....	5	Choke Cable .....	38
Towing.....	5	Air Filter Maintenance.....	39
Operating.....	5	Replacing Air Filter.....	39
Good Service.....	6	Fuel Filter.....	40
SYMBOLS AND DECALS .....	7	Tire Pressures .....	41
SAFETY .....	9	Parking Brake .....	41
Safety Instructions .....	9	V-belts.....	41
General Operation .....	9	Deck belt.....	42
Personal Safety Equipment .....	11	Pump belt.....	43
Slope Operation.....	11	Cutting Blades .....	43
Safe Handling of Gasoline .....	13	Blade replacement.....	44
General Maintenance .....	14	Adjusting the Mower Deck.....	45
Transport .....	16	Leveling deck.....	45
Roll over Protection system (ROPS) .....	17	Anti-scalp rollers .....	46
CONTROLS .....	18	Cleaning and Washing.....	47
Control Locations.....	18	Caster Wheels .....	47
Steering Control Levers.....	19	Hardware .....	47
Parking Brake .....	20	LUBRICATION .....	48
Throttle Control.....	20	Lubricating the Cables.....	49
Blade Switch .....	20	Front Wheel Mount .....	49
Ignition Switch.....	21	Front Wheel Bearings.....	49
Choke Control.....	21	Deck spindle .....	49
Fuses .....	21	Deck outer spindle .....	50
Fuel Tank .....	22	Engine Oil .....	50
Fuel Shut Off Valve.....	23	Engine Oil Filter .....	50
Cutting Height Adjuster .....	23	Changing the Engine Oil.....	51
Hour Meter.....	24	Engine Oil Levels.....	51
OPERATION .....	25	Hydraulic Pump .....	52
Training.....	25	Fluid Change .....	52
Steering .....	25	Purging Procedures.....	52
To move forward and backward.....	25	TROUBLESHOOTING .....	53
To turn to the right.....	25	STORAGE.....	55
To turn to the left.....	25	Storage .....	55
To zero turn.....	25	Winter Storage.....	55
Before Starting.....	26	Service.....	55
Starting the Engine .....	26	SCHEMATICS.....	56
Starting the engine with a weak battery.....	28	TECHNICAL DATA .....	57
To attach jumper cables.....	28	Accessories .....	61
Running .....	29	Torque Specifications.....	61
Operating on hills.....	30	CONFORMITY CERTIFICATES .....	62
Mowing Tips .....	31	Conformity Certificates .....	62
Stopping the Engine .....	32	SERVICE JOURNAL.....	63
Moving by Hand.....	33	After the First 5-8 Hours .....	64
Pump release valves .....	33	25-Hour Service.....	65
MAINTENANCE .....	34	50-Hour Service.....	66
Maintenance Schedule .....	34	100-Hour Service.....	67
Battery .....	36	300-Hour Service.....	68
Ignition System .....	37	At Least Once Each Year.....	69
Safety System.....	37		



**WARNING!**

Failure to follow cautious operating practices can result in serious injury to the operator or other persons. The owner must understand these instructions, and must allow only trained persons who understand these instructions to operate the mower.

Each person operating the mower must be of sound mind and body and must not be under the influence of any mind altering substance.



**WARNING!**

Engine exhaust, some of its constituents, and certain vehicle components contain or emit chemicals known to the State of California to cause cancer and birth defects or other reproductive harm.



**WARNING!**

Battery posts, terminals and related accessories contain lead and lead compounds, chemicals known to the State of California to cause cancer and birth defects or other reproductive harm. Wash hands after handling.

---

# INTRODUCTION

---

## **Congratulations**

Thank you for purchasing a Dixon ride-on mower. This machine is built for superior efficiency to rapidly mow primarily large areas. A control panel easily accessible to the operator and a hydrostatic transmission regulated by steering controls both contribute to the machine's performance.

This manual is a valuable document. Read the contents carefully before using or servicing the machine. The following of instructions (use, service, maintenance) by all who operate this machine is important for the safety of the operator and others. It can also considerably increase the life span of the machine and increase its resale value.

If you sell your machine, be sure to give the operator's manual to the new owner.

The final chapter of this operator's manual provides a Service Journal. Ensure that service and repair work are documented. A well-kept service journal reduces service costs for the maintenance and affects the machine's resale value. Please contact your dealer for more information. Take the operator's manual along when the machine is taken to your dealer for service.

## **General**

In this operator's manual, left and right, backward and forward are used in relation to the machine's normal driving direction.

Continuous dedication to improve our products require that specifications and design are subject to change without notice.

## **Driving and Transport on Public Roads**

Check applicable road traffic regulations before transporting on public roads. If the machine is transported, you must always use approved fastening equipment and ensure that the machine is well anchored. DO NOT operate this machine on public roadways.

## **Towing**

Do not tow this machine, it may cause damage to the drive system.

Do not tow any trailers with this mower. They may jackknife or overturn causing damage to the mower and possible serious injury to the operator.

## **Operating**

This machine is constructed only for mowing grass on lawns and even ground without obstacles such as stones, tree stumps, etc. The machine can also be used for other tasks when equipped with special accessories provided by the manufacturer. Operating instructions for the accessories are provided with delivery. All other types of uses are incorrect. The manufacturer's directions concerning operation, maintenance, and repairs must be carefully followed.

Lawn mowers and all power equipment, can be potentially dangerous if used improperly. Safety requires good judgement, careful use in accordance with these instructions and common sense.

The machine must only be operated, maintained, and repaired by persons familiar with the machine's special characteristics and who are also knowledgeable about the safety instructions. Use only approved repair parts to maintain this machine.

Accident prevention regulations, other general safety regulations, occupational safety rules, and traffic regulations must be followed without fail.

Unauthorized modifications to the design of the machine may absolve the manufacturer from liability for any resulting personal injury or property damage.

---

# INTRODUCTION

---

## Good Service

Dixon's products are sold all over the world and only in specialized retail stores with complete service. This ensures that you as a customer receive only the best support and service. Before the product is delivered, the machine has, for example, been inspected and adjusted by your retailer. See the certificate in the Service Journal in this operator's manual.

When you need spare parts or support in service questions, warranty issues, etc., please consult the following professional:

This Operator's Manual belongs to the machine with the manufacturing number:	Engine	Transmission

## Manufacturing Number

The machine's manufacturing number can be found on the printed plate affixed to the left in the engine compartment. Stated on the plate, from the top are:

- The machine's type designation (I.D.).
- The manufacturer's type number (Model).
- The machine's serial number (Serial no.)

*Please have the type designation and serial number available when ordering spare parts.*

The engine's manufacturing number is stamped on one of the valve covers.

The plate states:

- The engine's model.
- The engine's type.
- Code

*Please have these available when ordering spare parts.*

The wheel motors and hydrostatic pumps have a barcode decal affixed at the rear.

# SYMBOLS AND DECALS

These symbols are found on the machine and in the operator's manual. Study them carefully so that you know what they mean.

	<p><b>WARNING!</b></p> <p>Xxxx xxxxxx xxxxx xxxx          xxxxxxxxxxx xxxxxx xxxxxxxxxxxx.          xx xxxxxxxxxxx xxxxx xxxxxxx.</p>
---	---

Used in this publication to notify the reader of a risk of **personal injury or death**, particularly if the reader should neglect to follow instructions given in the manual.

<p><b>IMPORTANT INFORMATION</b></p> <p>Xxxx xxxxxx xxxxx xxxx xxxxxxxxxxxx          xxxxxxx xxxxxxxxxxxx. xx xxxxxxxxxxx xxxx          xxxxxxx.</p>
---

Used in this publication to notify the reader of a risk of **material damage**, particularly if the reader should neglect to follow instructions given in the manual. Used also when there is a potential for misuse or misassembly.

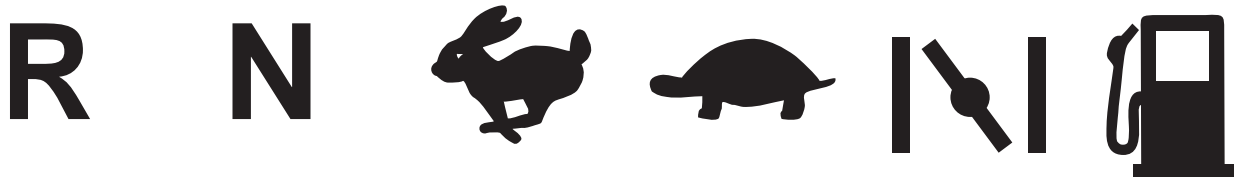

Reverse

Neutral

Fast

Slow

Choke

Fuel



Warning!



Parking Brake



CE conformity marking. Only for European market

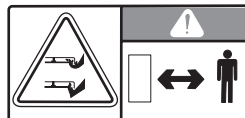

Warning! Rotating blades, keep away from the discharge deck

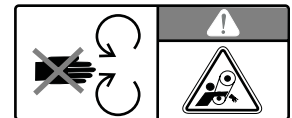

Do not touch parts



Battery acid is corrosive, explosive and flammable



Do not stand here



Use protective glasses



Use protective gloves

Noise emissions to the surroundings in accordance with the European Union's directive. The machine's emission is stated in the chapter TECHNICAL DATA and on the decals.

Only machines for European market

# SYMBOLS AND DECALS

Read  
Operator's  
Manual

Shut off engine and  
remove key before  
performing any  
maintenance or repair work

Keep a safe  
distance from  
the machine

Use on slopes  
no greater  
than 10°

No passengers

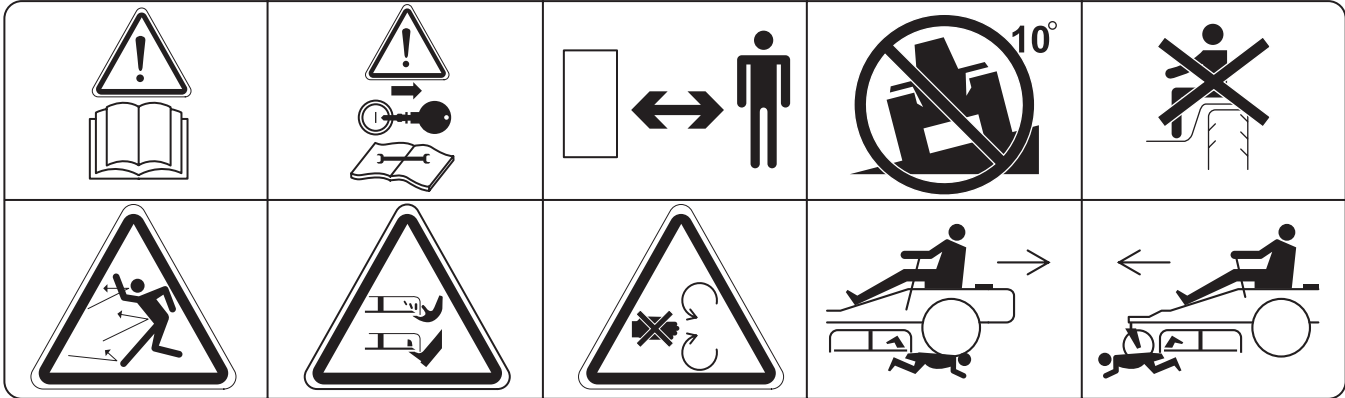

Whole body  
exposure to  
thrown objects

Severing of fingers  
and toes

Do not open or  
remove safety  
shields while  
engine is running

Careful backing up,  
watch for other  
people

Careful going  
forward, watch for  
other people



Moving sharp blades under cover



# SAFETY

## Safety Instructions

These instructions are for your safety. Read them carefully.



### WARNING!

This symbol means that important safety instructions need to be emphasized. It concerns your safety.

**IMPORTANT:** THIS CUTTING MACHINE IS CAPABLE OF AMPUTATING HANDS AND FEET AND THROWING OBJECTS. FAILURE TO OBSERVE THE FOLLOWING SAFETY INSTRUCTIONS COULD RESULT IN SERIOUS INJURY OR DEATH.

### General Operation

- Read, understand, and follow all instructions on the machine and in the manual before starting.
- Do not put hands or feet near rotating parts or under the machine. Keep clear of the discharge opening at all times.
- Only allow responsible adults, who are familiar with the instructions, to operate the machine.
- Clear the area of objects such as rocks, toys, wire, etc., which could be picked up and thrown by the blades.
- Be sure the area is clear of bystanders before operating. Stop machine if anyone enters the area.
- Never carry passengers. The machine is only intended for use by one person.
- Do not mow in reverse unless absolutely necessary. Always look down and behind before and while backing.
- Never direct discharged material toward anyone. Avoid discharging material against a wall or obstruction. Material may ricochet back toward the operator. Stop the blades when crossing gravel surfaces.
- Do not operate machine without the entire grass catcher, discharge guard, or other safety devices in place and working
- Slow down before turning.
- Never leave a running machine unattended. Always turn off blades, set parking brake, stop engine, and remove keys before dismounting.
- Disengage blades when not mowing. Shut off engine and wait for all parts to come to a complete stop before cleaning the machine, removing the grass catcher, or unclogging the discharge guard.

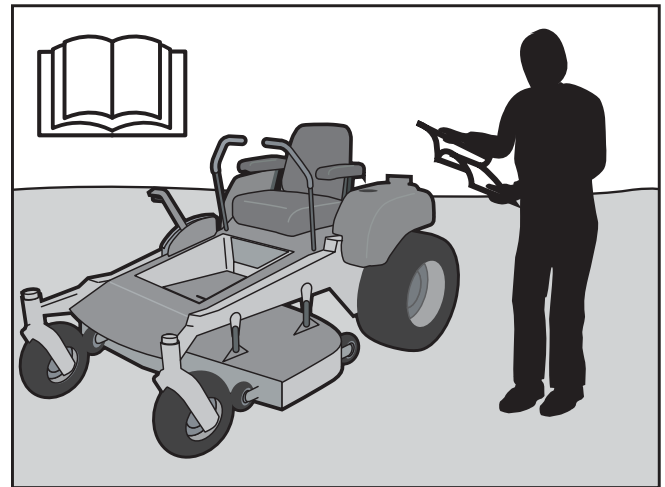

8011-512

*Read the operator's manual before starting the machine*

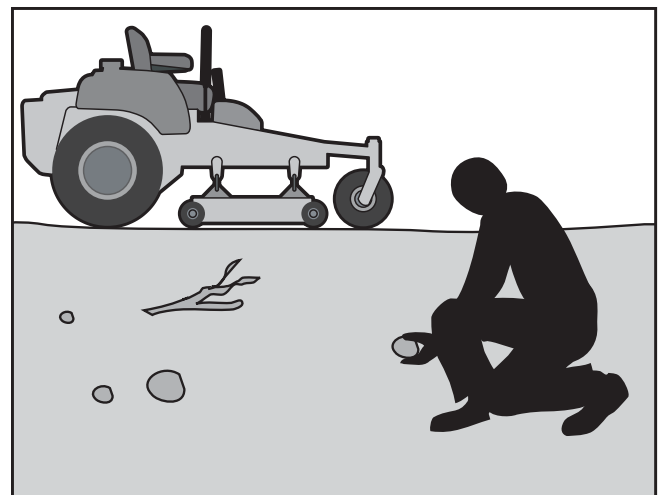

8011-513

*Clear the area of objects before mowing*

# SAFETY

- Operate machine only in daylight or good artificial light.
- Do not operate the machine while under the influence of alcohol or drugs.
- Watch for traffic when operating near or crossing roadways.
- Use extra care when loading or unloading the machine into a trailer or truck.
- Always wear eye protection when operating machine.
- Data indicates that operators age 60 years and above are involved in a large percentage of riding mower-related injuries. These operators should evaluate their ability to operate the riding mower safely enough to protect themselves and others from serious injury.
- Follow the manufacturer's recommendation for wheel weights or counterweights.
- Anyone who operates this machine must first read and understand this Operation Manual. Local laws may regulate the age of the user.
- Keep machine free of grass, leaves or other debris buildup which can touch hot exhaust / engine part and burn. Do not allow the mower deck to plow leaves or other debris which can cause buildup to occur. Clean any oil or fuel spillage before operating or storing the machine. Allow machine to cool before storage.



8011-520

*Never take passengers*



## **WARNING!**

**Engine exhaust and certain vehicle components contain or emit chemicals considered to cause cancer, birth defects, or other reproductive system damage. The engine exhaust contains carbon monoxide, which is a odorless, colorless, poisonous gas. Do not use the machine in enclosed spaces.**

# SAFETY

## Personal Safety Equipment



### WARNING!

**When using the machine, approved personal protective equipment (shown in illustrations) shall be used. Personal protective equipment cannot eliminate the risk of injury but it will reduce the degree of injury if an accident does happen. Ask your retailer for help in choosing the right equipment.**

- Make sure that you have first aid equipment close at hand when using the machine.
- Never use the machine when barefoot.
- Always wear protective shoes or boots, preferably with steel toe caps.
- Always wear approved protective glasses or a full visor when assembling or driving.
- Always wear gloves when handling the blades.
- Never wear loose clothing that can get caught in moving parts.
- Use ear protectors to avoid damage to hearing.

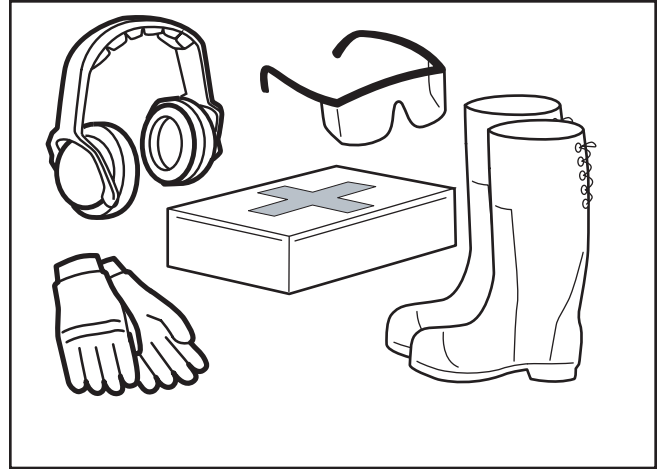

8011-670a

*Personal protective equipment*

## Slope Operation

Slopes are a major factor related to loss of control and tip-over accidents, which can result in severe injury or death. Operation on all slopes requires extra caution. If you cannot back up the slope or if you feel uneasy on it, do not mow it.

- Mow up and down slopes (10 degrees maximum), not across.
- Watch for holes, ruts, bumps, rocks, or other hidden objects. Uneven terrain could overturn the machine. Tall grass can hide obstacles.
- Choose a low ground speed so that you will not have to stop while on the slope.
- Do not mow on wet grass. Tires may lose traction.
- Avoid starting, stopping, or turning on a slope. If the tires lose traction, disengage the blades and proceed slowly straight down the slope.
- Keep all movement on the slopes slow and gradual. Do not make sudden changes in speed or direction, which could cause the machine to roll over.
- Use extra care while operating machine with grass catchers or other attachments; they can affect the stability of the machine.

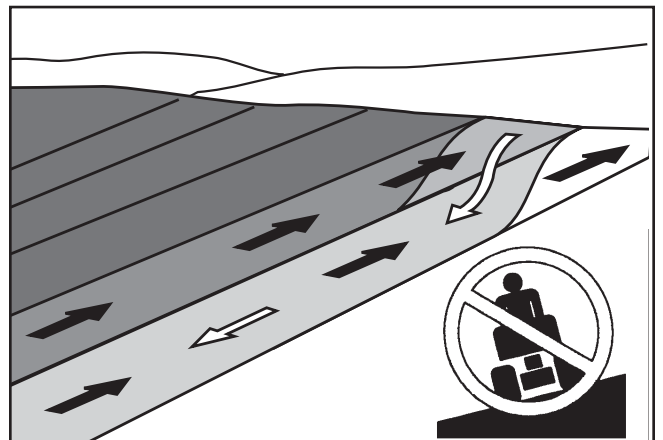

6003-004

*Mow up and down, not side to side*



### WARNING!

**Do not drive up or down hills with slopes greater than 10 degrees. And do not drive across any slopes.**

# SAFETY

- Do not use on steep slopes.
- Do not try to stabilize the machine by putting your foot on the ground.
- Do not mow near drop-offs, ditches, or embankments. The machine could suddenly roll over if a wheel is over the edge or if the edge caves in.

## Children

Tragic accidents can occur if the operator is not alert to the presence of children. Children are often attracted to the machine and the mowing activity. *Never* assume that children will remain where you last saw them.

- Keep children out of the mowing area and in the watchful care of a responsible adult other than the operator.
- Be alert and turn machine off if a child enters the area.
- Before and while backing, look behind and down for small children.
- Never carry children, even with the blades shut off. They may fall off and be seriously injured or interfere with safe machine operation. Children who have been given rides in the past may suddenly appear in the mowing area for another ride and be run over or backed over by the machine.
- Never allow children to operate the machine.
- Use extra care when approaching blind corners, shrubs, trees, or other objects that may block your view of a child.



8011-509

*Be extra cautious when driving on slopes*

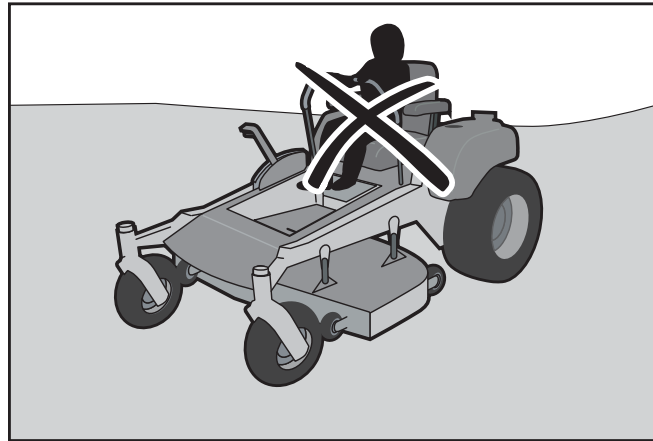

8011-517

*Never allow children to operate the machine*



8011-518

*Keep children away from work area*

# SAFETY



## WARNING!

**The engine must not be started when the driver's floor plate or any protective plate for the mower deck's drive belt is removed.**

## Safe Handling of Gasoline

To avoid personal injury or property damage, use extreme care in handling gasoline. Gasoline is extremely flammable and the vapors are explosive.

- Extinguish all cigarettes, cigars, pipes, and other sources of ignition.
- Use only approved gasoline container.
- Never remove gas cap or add fuel with the engine running. Allow engine to cool at least two (2) minutes before refueling.
- Never fuel the machine indoors.
- Never store the machine or fuel container where there is an open flame, spark, or pilot light such as on a water heater or other appliance.
- Before you begin refueling, minimize the risk of static electricity by touching a metal surface.
- Never fill containers inside a vehicle or on a truck or trailer bed with plastic liner. Always place containers on the ground away from the vehicle when filling.
- Remove gas-powered equipment from the truck or trailer and refuel it on the ground. If this is not possible, refuel such equipment with a portable container, rather than from a gasoline dispenser nozzle.
- Keep the nozzle in contact with the rim of the fuel tank or container opening at all times until fueling is complete. Do not use a nozzle lock-open device.
- If fuel is spilled on clothing, change clothing immediately.
- Never overfill fuel tank. Replace gas cap and tighten securely.
- Do not start the engine near spilled fuel.
- Never use gasoline as a cleaning agent.
- If leaks arise in fuel system, engine must not be started until problem has been resolved.
- Check the fuel level before each use and leave space for the fuel to expand, as the heat from the engine and the sun may otherwise cause the fuel to expand and overflow.



8011-516

*Never fill the fuel tank indoors*



## WARNING!

**The engine and the exhaust system become very hot during operation.**

**There is risk for burns if touched.**

**Allow engine and exhaust system to cool at least two (2) minutes before refueling.**

# SAFETY

## General Maintenance

- Never operate machine in a closed area.
- Keep all nuts and bolts tight to be sure the equipment is in safe working condition.
- Never tamper with safety devices. Check their proper operation regularly.
- Keep machine free of grass, leaves, or other debris buildup. Clean oil or fuel spillage and remove any fuel-soaked debris. Allow machine to cool before storing.
- If you strike a foreign object, stop and inspect the machine. Repair, if necessary, before restarting.
- Never make any adjustments or repairs with the engine running.
- Check grass catcher components and the discharge guard frequently and replace with manufacturer's recommended parts, when necessary.
- Mower blades are sharp. Wrap the blade or wear gloves, and use extra caution when servicing them.
- Check brake operation frequently. Adjust and service as required.
- Maintain or replace safety and instruction labels, as necessary.
- Do not modify safety equipment. Check regularly to be sure it works properly. The machine must not be driven with defective or unmounted protective plates, protective cowlings, safety switches, or other protective devices.
- Do not change the settings of governors and avoid running the engine with overly high engine speeds. If you run the engine too fast, you risk damaging the machine components.
- Be very careful when handling battery acid. Acid on skin can cause serious corrosive burns. If you spill battery acid on your skin, rinse immediately with water.
- Acid in the eyes can cause blindness, contact a doctor immediately.
- Be careful when servicing the battery. Explosive gases form in the battery. Never perform maintenance on the battery when smoking or near open flames or sparks.
- The battery can explode and cause serious injury/damage.

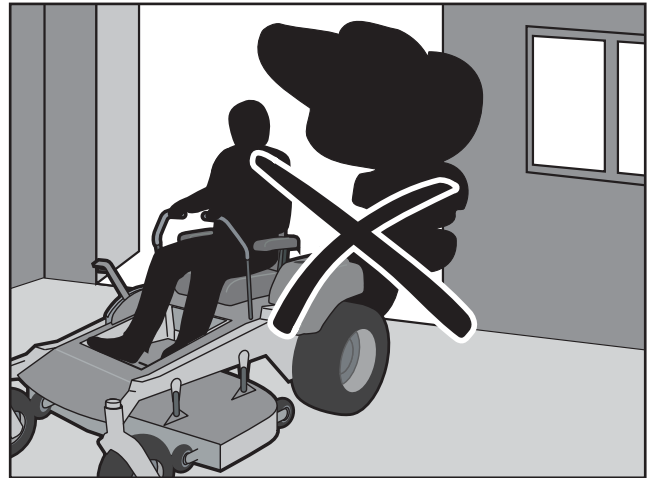

8011-515

*Never drive the machine in an enclosed space*



**Use protective glasses for maintenance work.**



### **WARNING!**

**The battery contains lead and lead compounds, chemicals that are considered to cause cancer, birth defects, and other reproductive system damage. Wash your hands after handling the battery.**

# SAFETY

- Ensure that nuts and bolts, especially the fastening bolts for the blade attachments, are properly tightened, torqued and that the equipment is in good condition.
- Do not modify safety equipment. Check regularly to be sure it works properly. The machine must not be driven with defective or unmounted protective plates, protective cowlings, safety switches, or other protective devices.
- Do not change the settings of governors and avoid running the engine with overly high engine speeds. If you run the engine too fast, you risk damaging the machine components.
- Sparking can occur when working with the battery and the heavy cables of the starter circuit. This can cause battery explosion, fire or eye injury. Sparking in this circuit can not occur after the chassis cable (normally negative, black) is removed from the battery.

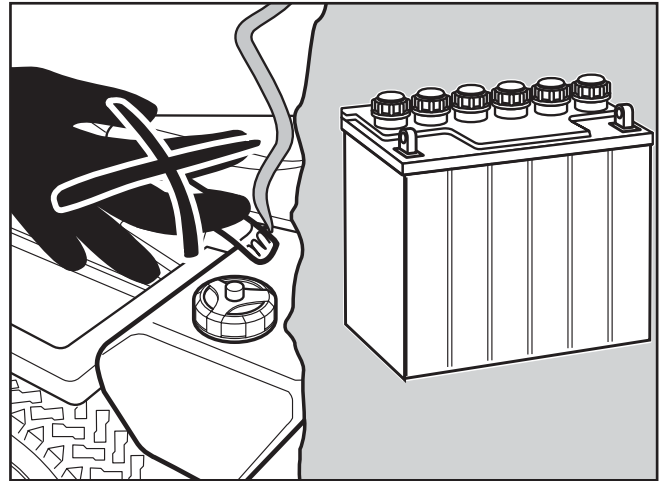

6003-009

*Do not smoke when performing maintenance on the battery. The battery can explode and cause serious injury/damage.*



## **WARNING!**

**Avoid electrical sparking and its consequences by the following routines:**

- Use protective goggles.
- Ensure that the fuel filler cap is mounted tightly and no flammable substances are stored in an open vessel.
- Never work with the starter circuit if there is spilled fuel.
- Disconnect the chassis cable from the battery first and reconnect it last.
- Do not make a bridge short circuit across the starter relay to run the starter.
- Never use the machine indoors or in spaces lacking proper ventilation. The exhaust fumes contain carbon monoxide, an odorless, poisonous, and lethal gas.
- Stop and inspect the equipment if you run over or into anything. If necessary, make repairs before starting.
- Never make adjustments with the engine running.
- The machine is tested and approved only with the equipment originally provided or recommended by the manufacturer. Only use approved repair parts for the machine.

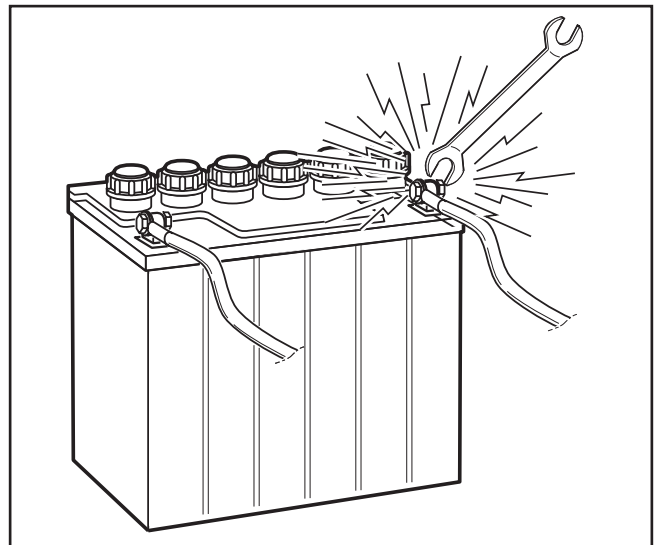

8009-728

*Risk of sparking*

# SAFETY

- The blades are sharp and can cause cuts and gashes. Wrap the blades or use protective gloves when handling them.
- Check the parking brake's functionality regularly. Adjust and service as necessary.
- The mulch blades should only be used in familiar areas when higher quality mowing is desired.
- Reduce the risk of fire by removing grass, leaves, and other debris that may have accumulated on the machine. Allow the machine to cool before putting it in storage.
- Regularly clean deck and underside of deck, avoid spraying engine and electrical components with water.

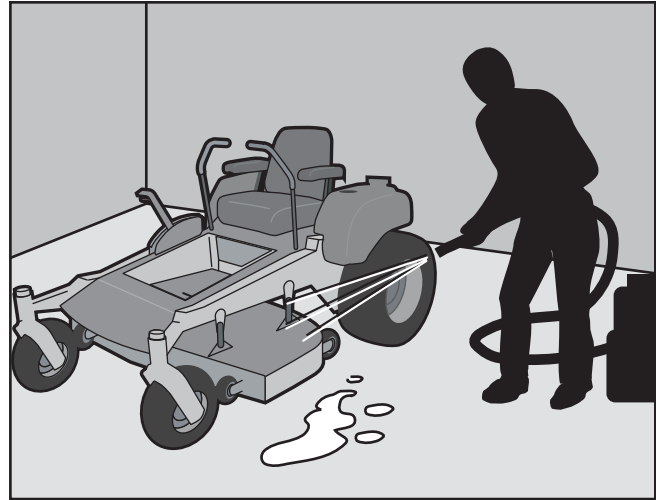

8011-514

*Regularly clean deck*

## Transport

- The machine is heavy and can cause serious crushing injuries. Be extra cautious when it is loaded on or unloaded from a vehicle or trailer.
- Use an approved trailer to transport the machine. Activate the parking brake, turn off the fuel supply, and fasten the machine with approved fastening devices, such as bands, chains, or straps, when transporting.
- Do not operate this machine on public roadways.
- Check and abide by local traffic regulations before transporting the machine on any road.
- Do not tow this machine, it may cause damage to the drive system.
- Do not tow with this mower. They may jackknife or overturn causing damage to the mower and possibly serious injury to the operator.
- Load the unit onto truck or trailer by driving up ramps of suitable strength using a slow speed. Do not lift! The machine is not intended to be lifted by hand.



### WARNING!

**Escaping hydraulic oil under pressure can have sufficient force to penetrate the skin, causing serious injury. If injured by escaping fluid, see a doctor at once. Serious infection or reaction can develop if proper medical treatment is not administered immediately.**

### IMPORTANT INFORMATION

**The parking brake is not sufficient to lock the machine in place during transport. Ensure that the machine is well fastened to the transport vehicle. Always reverse the machine onto the transport vehicle to avoid tipping it over.**



---

# SAFETY

---

## Roll over Protection system (ROPS)

The ROPS increases the basic weight of the unit by 42 lbs/19 kg. The ROPS is an accessory.

- Do not use ROPS as a lifting, attaching or anchoring point.
- Do not use ROPS for wrecking or towing.
- Do not exceed Max GVW: 2822 lbs/1283 kg.
- Read machine operator's manual before each use.
- Securely fasten your seat belt if the unit has a ROPS.
- Where possible, avoid operating the unit near ditches, embankments and holes.
- Reduce speed when turning, crossing slopes and on rough, slick or muddy surfaces.
- Stay off slopes too steep for safe operation.
- Watch where you are going, especially at row ends, on roads and around trees.
- Do not permit others to ride.
- Operate the mower smoothly - no jerky turns, starts or stops.
- When mower is stopped, set brakes securely and use park brake.
- If any part of ROPS is damaged, the entire ROPS must be replaced.
- Check all bolts including seat belt for correct torque before each use.
- Check ROPS structure for damage before each use.
- ROPS bar is NOT intended for use in sub zero temperatures.



### **WARNING!**

**The rollover protection system's capabilities may be impaired by damage if the mower is overturned or if alteration to the ROPS occurs. If these conditions take place, the total structure MUST be replaced.**



### **WARNING!**

**This mower is equipped with an internal combustion engine and should not be used on or near any unimproved forested, bush covered or grassy lands unless the engine's system is equipped with a spark arrester meeting applicable local or state laws (if any). If a spark arrester is used, it should be maintained in effective working order by the operator.**

# CONTROLS

This operator's manual describes the Dixon Zero Turn Rider. The rider is fitted with a Kohler four-stroke overhead valve engine developing 25-27 horse power\*.

Transmission from the engine is made via a belt-driven hydraulic pumps. Using the left and right steering controls, the flow is regulated and thereby the direction and speed.

## Control Locations

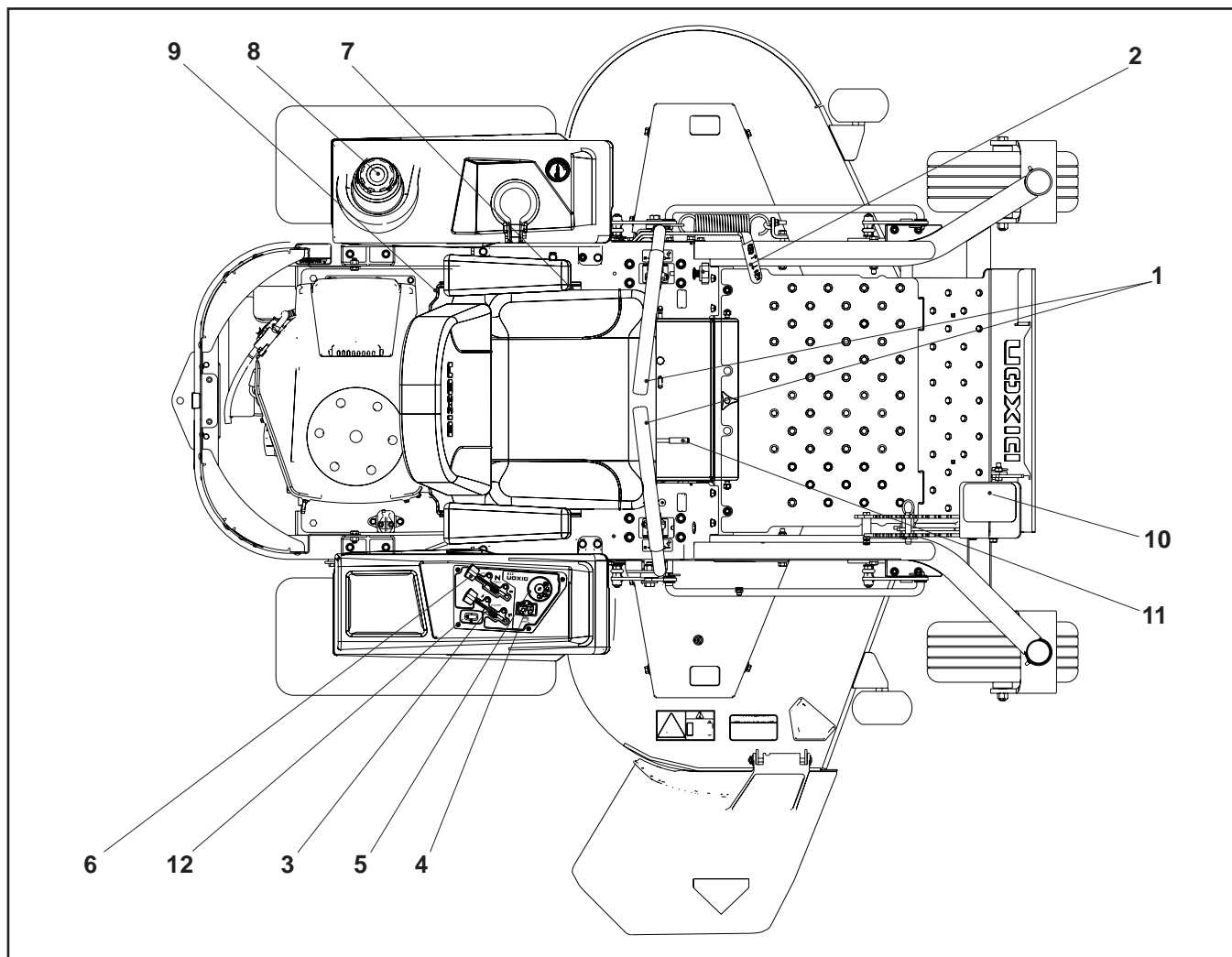

- |                          |                           |
|--------------------------|---------------------------|
| 1. Motion control levers | 7. Fuses                  |
| 2. Parking brake         | 8. Fuel tank cap          |
| 3. Throttle control      | 9. Fuel shut off valve    |
| 4. Blade switch          | 10. Deck lift             |
| 5. Ignition switch       | 11. Seat adjustment lever |
| 6. Choke control         | 12. Hour meter            |

*\*As rated by the engine manufacturer.*

# CONTROLS

## 1. Steering Control Levers

The machine's speed and direction are continuously variable using the two steering controls. The steering controls can be moved forward or backward about a neutral position. Furthermore, there is a neutral position, which is locked if the steering controls are moved outward.

When both controls are in the neutral position (N), the machine stands still.

By moving both controls an equal amount forward or backward, the machine moves in a straight line forward or backward respectively.

In order, for example, to turn right while moving forward, move the right control towards the neutral position. The rotation of the right wheel is reduced and the machine turns to the right.

Zero turn can be achieved by moving one control backward (behind the neutral position) and carefully moving the other steering control forward from its neutral position. The rotation direction when zero turning is determined by which steering control is moved backward behind the neutral position. If the left steering control is pulled backward, the machine turns to the left. Use extra care when using this maneuver.

If the steering controls are in uneven positions when standing still or do not fit in the slots for moving the controls outward, they can be adjusted.

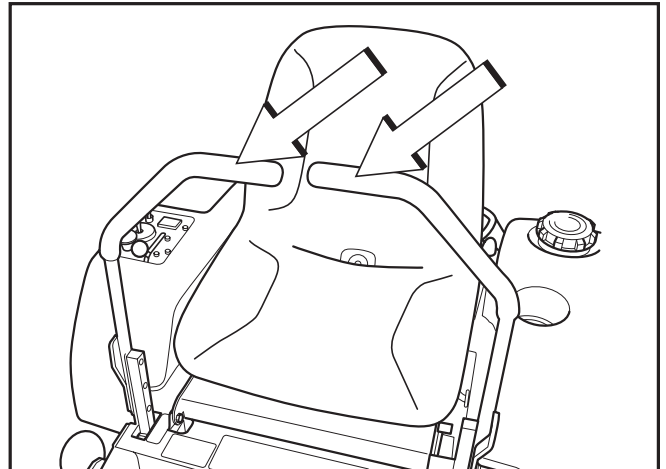

Steering controls

8011-789



### WARNING!

The machine can turn very rapidly if one steering control is moved much further forward than the other.

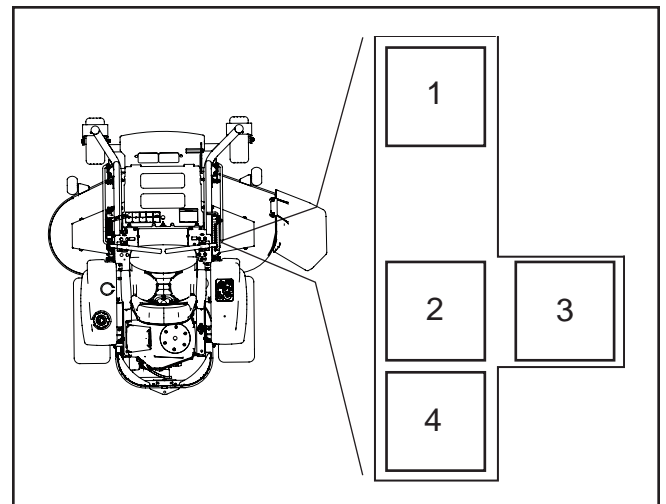

8011-7912

1. Forward
  2. Neutral
  3. Neutral slot, Neutral lock
  4. Reverse
- Motion control lever, right side*

# CONTROLS

## 2. Parking Brake

### IMPORTANT INFORMATION

The machine must stand absolutely still when applying the parking brake. Always set the parking brake before dismounting. Release the parking brake before moving the mower.

The parking brake is found on the left of the machine. Pull the lever backward to activate the brake and forward to release it.

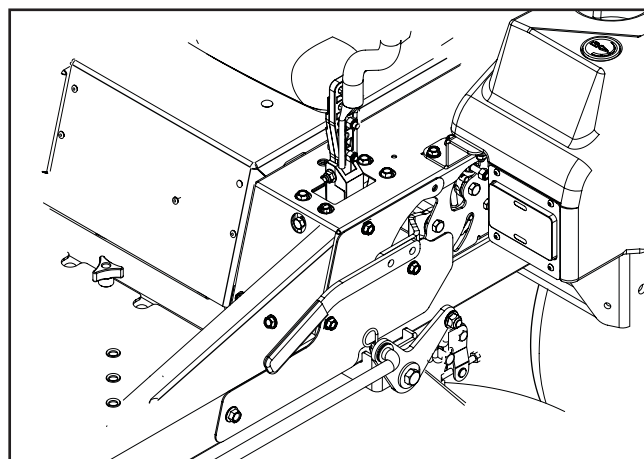

8061-019

*Parking brake not activated*

## 3. Throttle Control

The throttle control regulates the engine speed and thereby the rate of rotation of the blades, assuming the blade switch is pulled out, see Engaging the Mower Deck.

In order to increase or decrease the engine speed, the control is moved forward or back respectively.

Avoid idling the engine for long periods, as there is a risk of fouling the spark plugs.

USE FULL THROTTLE WHEN MOWING, for best mower performance and battery charging.

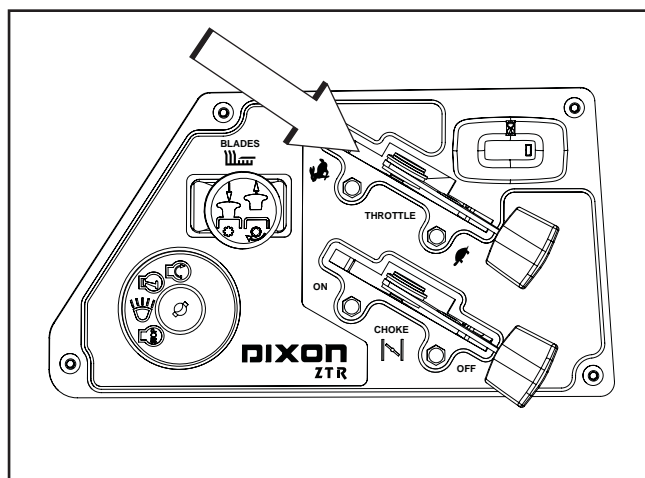

8061-017

*Throttle control*

## 4. Blade Switch

In order to engage the mower deck, pull the knob out; the mower blades are disengaged when the knob is depressed.

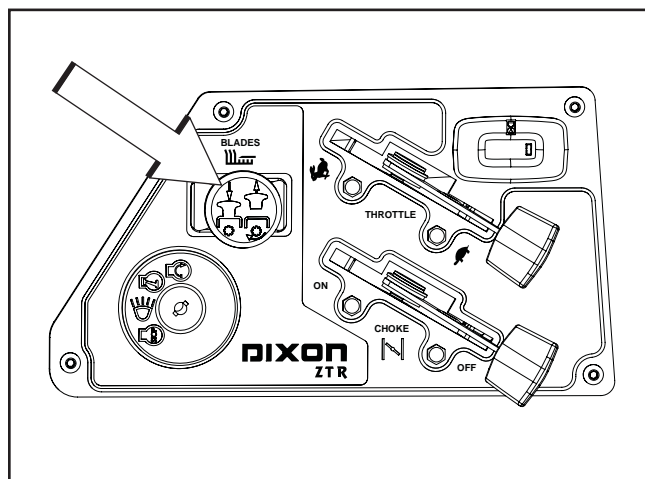

8061-017

*Blade switch*

# CONTROLS

## 5. Ignition Switch

The ignition key is placed on the control panel and is used to start and stop the engine.

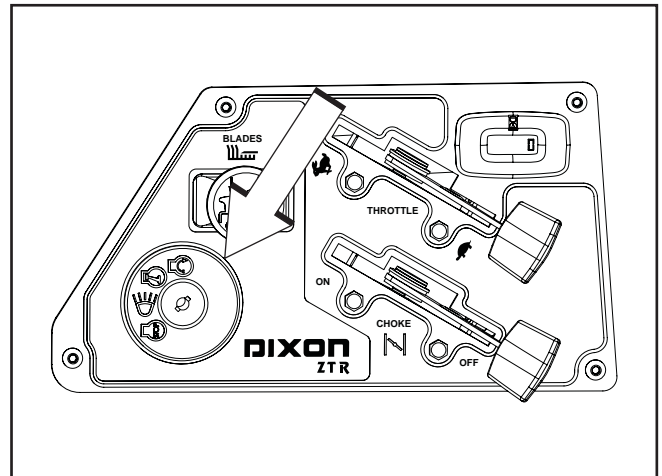

8061-017

Ignition switch

## 6. Choke Control

The choke control is used for cold starts in order to provide the engine with a richer fuel mixture.

For cold starts the control should be pushed to the ON position.

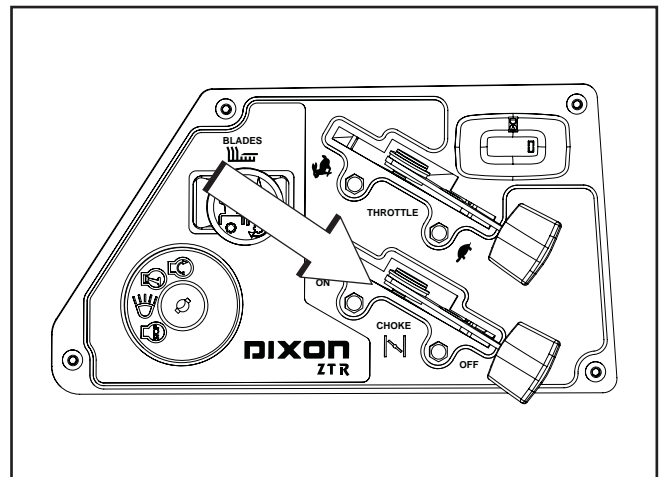

8061-017

Choke control

## 7. Fuses

Fuses are located on the left hand side of the machine. They are accessed by tilting the seat forward. They are flat pin fuses of the same type used in automobiles.

There are two fuses with ratings and functions:

- 20 A, Primary fuse.
- 7.5 A, Mower deck coupling.

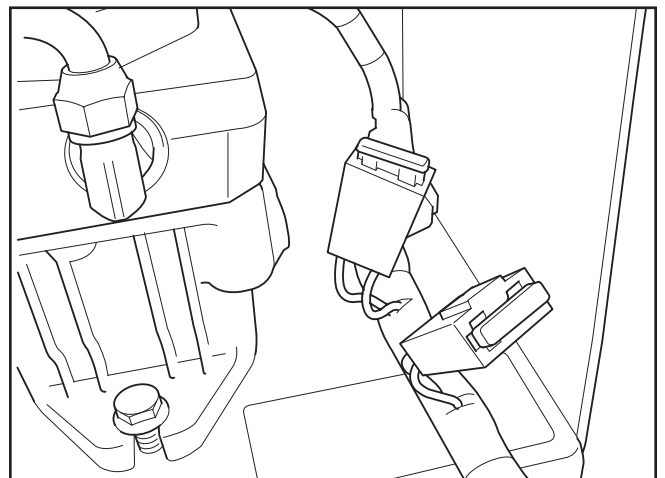

8011-420

Fuses

# CONTROLS

## 8. Fuel Tank

Read the safety instructions before refueling. The machine has one fuel tank, just behind the seat. The tank capacity is 5.7 gallons (22 liters).

Make sure the fuel cap is properly tightened and the cap gasket is not damaged.

The engine will run on a minimum of 85-octane unleaded gasoline (no oil mix). Environmentally adapted alkylate gasoline can be used. See also Technical Data concerning ethanol fuel. Methanol fuel is not allowed. Do not use E85 alcohol based fuel. Damage to engine and components may occur.

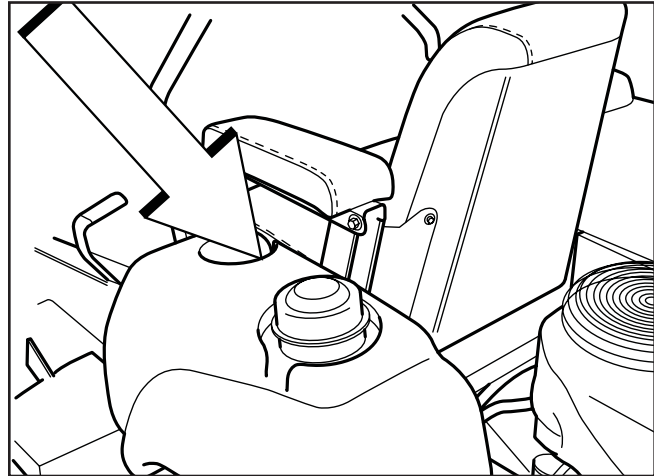

8011-625

Fuel tank



### WARNING!

**Gasoline is highly flammable. Observe caution and fill the tank outdoors (see the safety instruction).**



### WARNING!

**The engine and the exhaust system, become very hot during operation.**

**Risk for burns if touched.**

**Allow engine and exhaust system to cool at least two (2) minutes before refueling**



### WARNING!

**Fill to bottom of filler neck. Do not overfill. Wipe off any spilled oil or fuel. Do not store, spill or use gasoline near an open flame.**

### IMPORTANT INFORMATION

**Experience indicates that alcohol blended fuels (called gasohol, ethanol or methanol) can attract moisture which leads to separation and formation of acids during storage. Acidic gas can damage the fuel system of an engine while in storage. To avoid engine problems, the fuel system should be emptied before storage of 30 days or longer. Drain the gas tank, start the engine and let it run until the fuel lines and carburetor are empty. Use fresh fuel the next season. See Storage Instructions for additional information. Never use engine or carburetor cleaners in the fuel tank or permanent damage may occur.**

When operating in temperatures below 32° F. (0° C.), use fresh, clean winter grade gasoline to help insure good cold weather starting.

# CONTROLS

## 9. Fuel Shut Off Valve

The fuel shut off valve is located at the left rear of the seat. The valve is off when the handle tab is turned perpendicular to the fuel line.

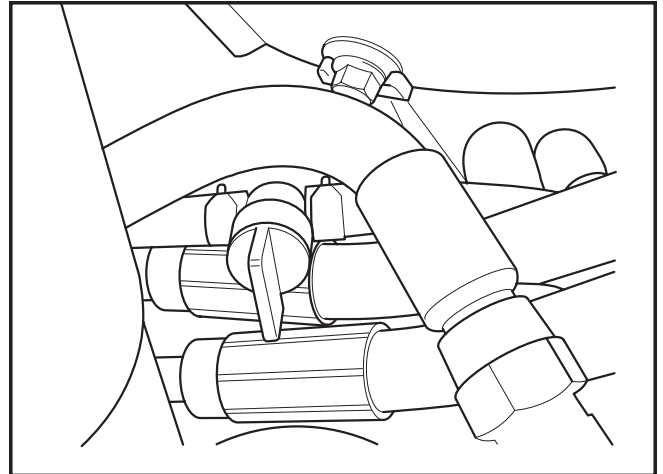

8011-419

*Fuel shut off valve in the CLOSED position*

## 10. Cutting Height Adjuster

The deck cutting height is obtained by pressing the foot pedal forward to lift the deck. To lower the deck, apply pressure to the top side of the foot pedal and allow it to pivot while the lift arm rotates to the rear of the unit. To stop in the desired cutting position, rotate the foot pedal down into the notch in the height plate. The cutting height range is from 1½" (38mm) to 4½" (114mm) in ¼ (6mm) increments. The heights are measured from the ground up to the blade tip with the engine not running.

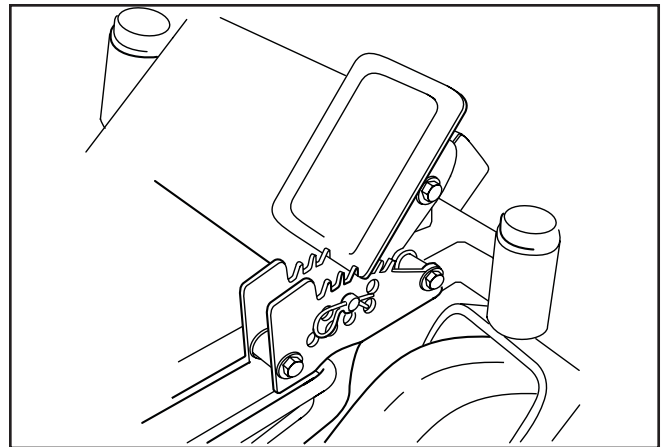

8050-117

*The mower deck's lifting lever*

### IMPORTANT INFORMATION

**In order to obtain an even cutting height, it is important that the air pressure in the front tires is 15 psi and the rear tires is 10 psi.**

### IMPORTANT INFORMATION

**Always use the high position to transport.**

# CONTROLS

## 11. Seat Adjustment Lever

The seat can be adjusted lengthways. When making adjustments, the lever under the front edge of the seat is moved to the left (as seen by the driver in the seat), after which the seat can be moved backward or forward.

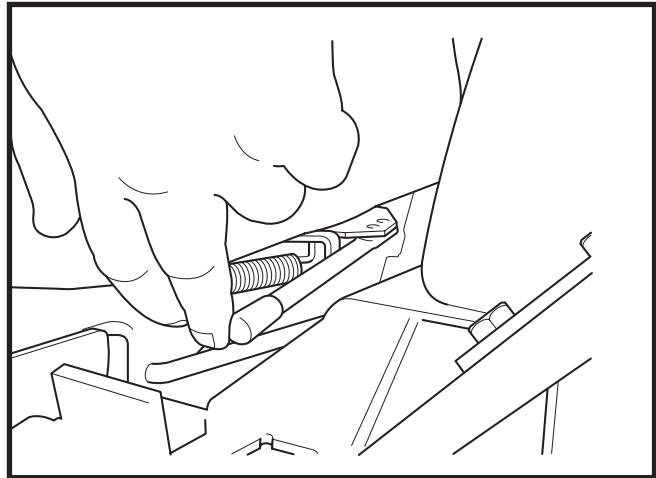

8011-441

*Lengthways adjustment*

## 12. Hour Meter

The hour meter displays the total operating time. It will flash CHG OIL (Change Oil) at 50 hour intervals. The flash duration is one hour before and one hour after the interval. The CHG OIL icon will come on and shut off automatically. The hour meter cannot be manually reset.

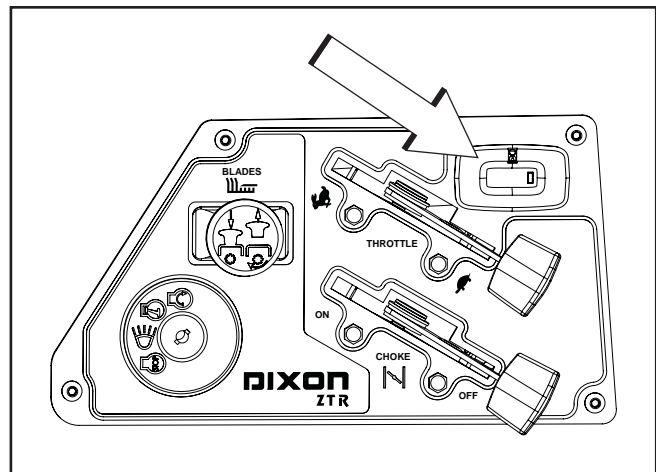

8011-441

*Hour meter*



---

# OPERATION

---

Read "Safety Instructions" section and following pages, if you are unfamiliar with the machine.

## Training

Zero turn mowers are far more maneuverable than typical riding mowers due to their unique steering capabilities.

We suggest that this section be reviewed in its entirety prior to attempting to move the mower under its own power. Additionally, we suggest when first operating the mower, use a reduced throttle speed and reduced ground speed by NOT moving control levers to the furthest forward or reverse positions during initial operation, or until operator becomes comfortable with controls. We also suggest first time users, or new users to Zero Turn mowers to become familiar with the mower's movement on a hard surface, such as concrete or blacktop PRIOR to attempting to operate on turf. Until operator becomes comfortable with mower controls and zero turning capability, they may damage turf due to overly aggressive maneuvers.

### IMPORTANT INFORMATION

**When control levers are in the reverse position they return to neutral when released. This may cause the mower to suddenly stop.**

## Steering

### To move forward and backward

The direction and speed of the mower's movements is effected by the movement of the control lever(s) on each side of mower. The left control lever controls the left wheel. The right control lever controls the right wheel.

First time users should push mower (see "Moving by Hand" in the *Operation* section) to an open, flat area, without other people or vehicles/obstacles nearby. In order to move unit under its own power, the operator must be in the seat, start engine (see "Before Starting" in *Operation* section), adjust engine speed to idle, disengage parking brake, do not engage blades at this time, rotate control levers inward. As long as the control levers have not been moved forward or backwards, mower will not move. Slowly move both control levers forward slightly. This will allow mower to start moving forward in a straight line. Pull back on control levers to the neutral position and mower should stop moving. Pull back slightly on control levers, this will allow mower to start moving backwards. Push forward on control levers to the neutral position and mower should stop moving.

### To turn to the right

While moving in a forward direction, pull the right lever back towards the neutral position while maintaining the position of the left lever, this will slow the rotation of the right wheel and cause the machine to turn in that direction.

### To turn to the left

While moving in a forward direction pull the left lever back towards the neutral position while maintaining the position of the right lever, this will slow the rotation of the left wheel and cause the machine to turn in that direction.

### To zero turn

While moving in a forward direction, first pull both control levers back until the mower stops or slows dramatically.

Then by alternating one lever slightly to the forward position and the other in the reverse position.

# OPERATION

## Before Starting

- Read the sections Safety Instructions and Controls before starting the machine.
- Perform the daily maintenance before starting (see Maintenance Schedule in the Maintenance section).
- Check that there is sufficient fuel in the fuel tank.
- Adjust the seat to the desired position.

The following conditions must be fulfilled before the engine can be started:

- The driver must be seated on the seat.
- The blade switch for engaging the mower blades must be depressed.
- The parking brake must be on.
- Both steering controls must be in the locked (outer) neutral position.

## Starting the Engine

1. Sit on the seat.
2. Raise the mower deck by pulling the lifting lever backward to the locked position (transport position).
3. Activate the parking brake.

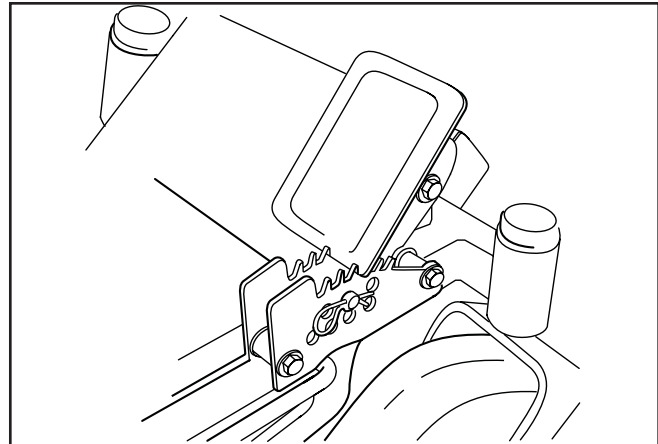

The mower deck's lifting lever

8050-117

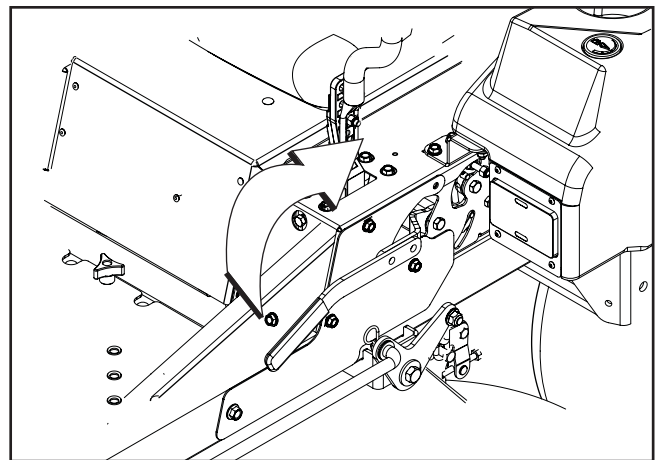

Parking brake not activated

8061-019

Disengage the mower blades by pressing the blade switch downwards.

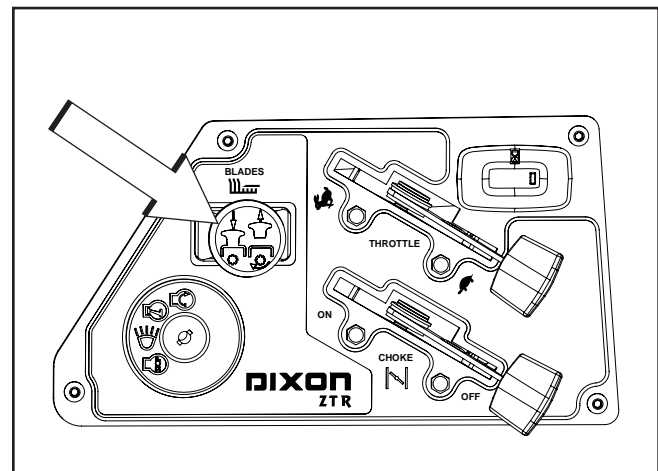

Hour meter

8011-441

# OPERATION

Move the steering controls outward to the locked (outer) neutral position.

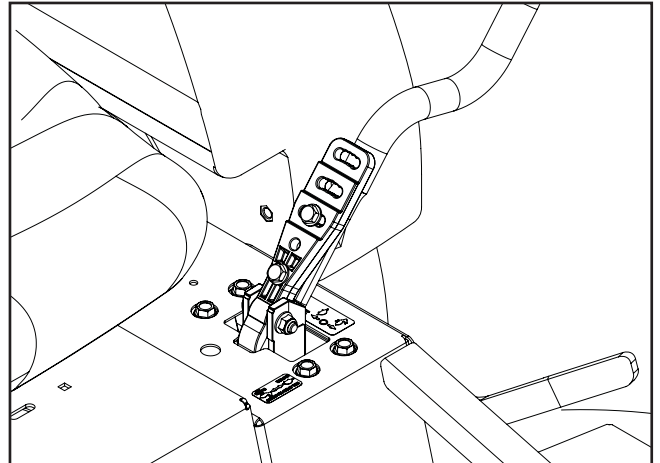

8061-012

*Place controls in neutral position*

Move the throttle to the middle position.



## WARNING!

Engine exhaust and certain vehicle components contain or emit chemicals considered to cause cancer, birth defects or other reproductive system damage. The engine exhaust contains carbon monoxide, which is a odorless, colorless, poisonous gas. Do not use the machine in enclosed spaces.

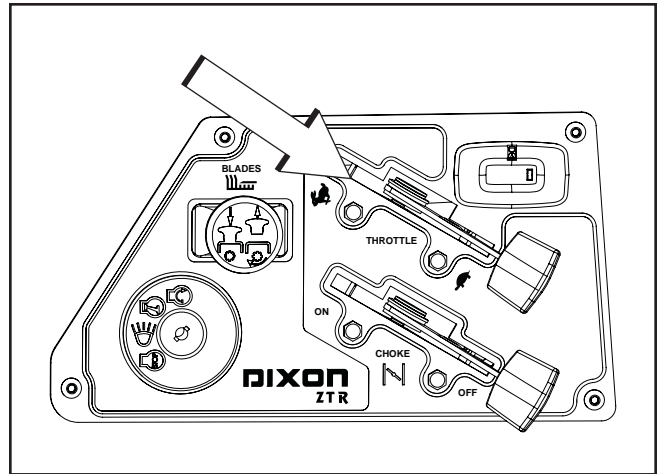

8061-001

*Set the throttle*

If the engine is cold, the choke lever should be pushed to the ON position.

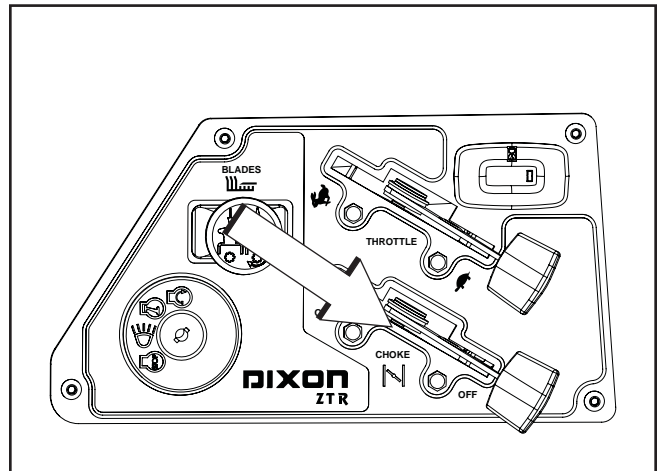

8061-004

*Set the choke control*

# OPERATION

## Starting the engine with a weak battery



### WARNING!

Lead-acid batteries generate explosive gases. Keep sparks, flame and smoking materials away from batteries. Always wear eye protection when around batteries.



### IMPORTANT INFORMATION

Your mower is equipped with a 12-volt negative grounded system. The other vehicle must also be a 12-volt negative grounded system. Do not use your mower to start other vehicles.

If your battery is too weak to start the engine, it should be recharged. (See "Battery" in the Maintenance Section.)

If "jumper cables" are used for emergency starting, follow this procedure:

#### To attach jumper cables

- Connect each end of the RED cable to the POSITIVE (+) terminal on each battery, taking care not to short against chassis.
- Connect one end of the BLACK cable to the NEGATIVE (-) terminal of the fully charged battery.
- Connect the other end of the BLACK cable to a good CHASSIS GROUND on the mower with the discharged battery, away from the fuel tank and battery.

#### To remove cables, reverse order

- Remove BLACK cable first from chassis and then from the fully charged battery.
- Remove RED cable last from both batteries.

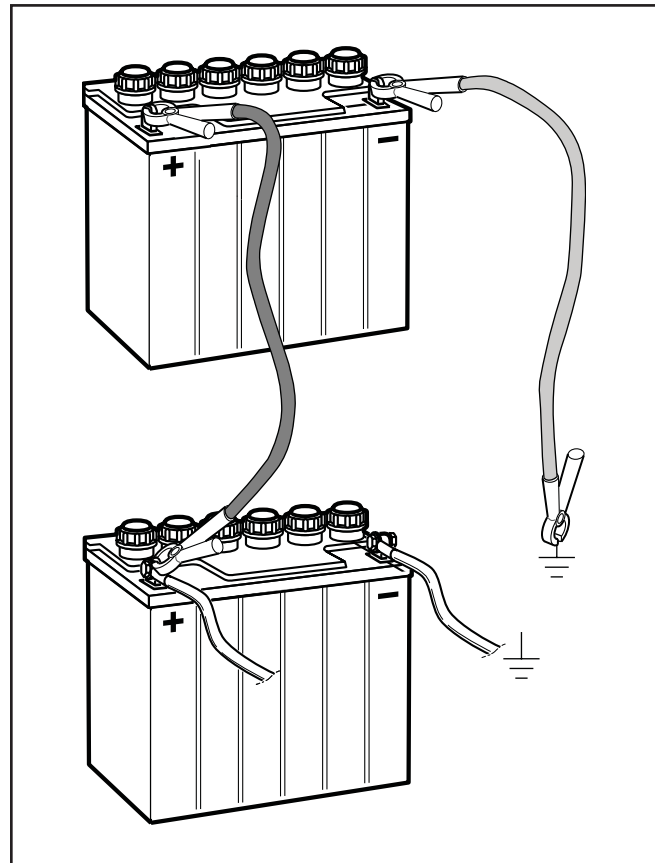

Jumper cable connection

8011-642

# OPERATION

## Running

1. Release the parking brake by moving the lever downward.  
NOTE: The mower is equipped with an operator presence system. When the engine is running, any attempt by the operator to leave the seat without first setting the parking brake will shut off the engine.
2. Move the steering controls to the neutral position (N).

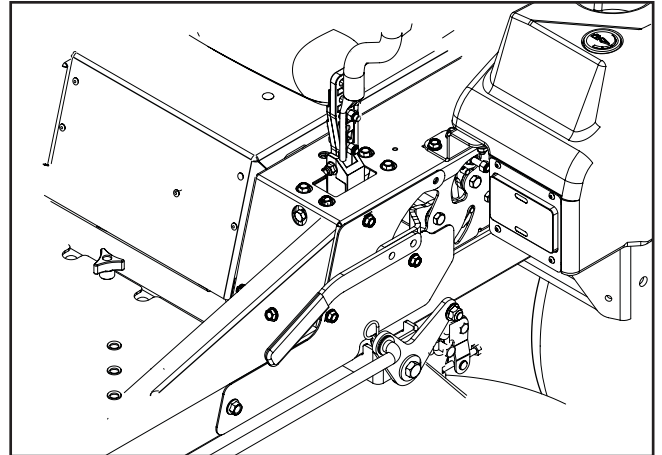

8061-019

Released parking brake

3. Select the cutting height with the cutting height adjustment pedal.
4. Make sure the work area is free from objects that could be thrown by the rotating blades.
5. Engage the mower deck by pulling out the blade switch.



### WARNING!

Ensure that no one is near mower when engaging blade switch.

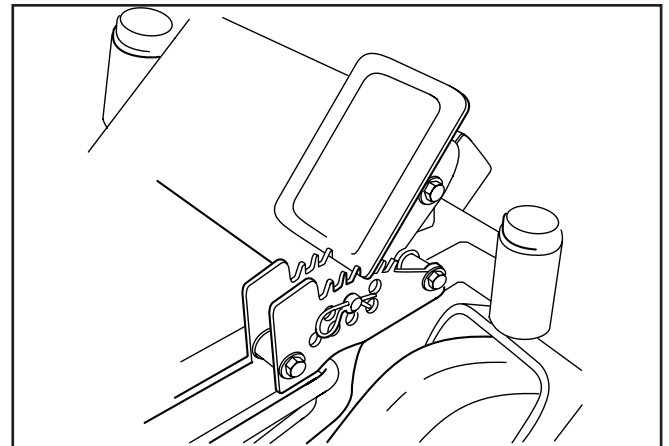

8050-117

The mower deck's lifting lever

6. Move throttle control to full throttle.
7. The machine's speed and direction are continuously variable using the two steering controls. When both controls are in the neutral position, the machine stands still. By moving both controls an equal amount forward or backward, the machine moves in a straight line forward or backward respectively.  
In order, for example, to turn right while moving forward, move the right control towards the neutral position. The rotation of the right wheel is reduced and the machine turns to the right.  
Turning on the spot (zero turn) can be achieved by moving one control backward (behind the neutral position) and carefully moving the other steering control forward from its neutral position.

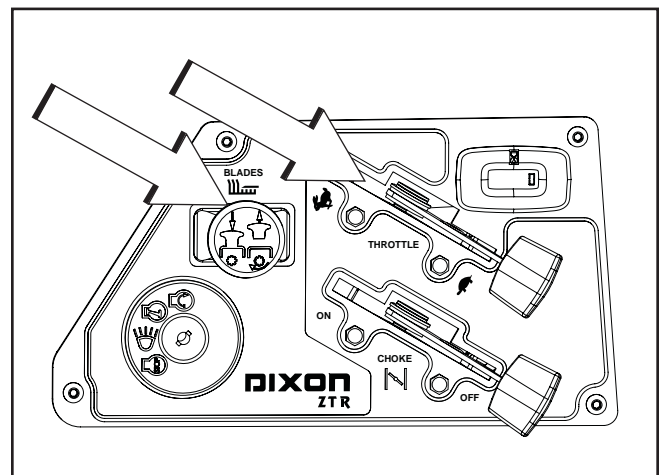

8061-017

Set blade engagement and throttle control

# OPERATION

## Operating on hills

Read the Safety Instructions "Driving on Slopes" in the "Safety Instructions".



### WARNING!

**Do not drive up or down hills with slopes greater than 10 degrees.  
Do not drive across slopes.**

- The slowest speed possible should be used before starting up or down hills.
- Avoid stopping or changing speed on hills.
- If stopping is absolutely necessary, pull drive levers into the neutral position and push to the outside of the unit and engage the parking brake.

### IMPORTANT INFORMATION

**Control levers return to neutral when released. This may cause the mower to suddenly stop.**

- To restart movement, release the parking brake.
- Pull the control levers back to the center of the mower and press forward to regain forward motion.
- Make all turns slowly.

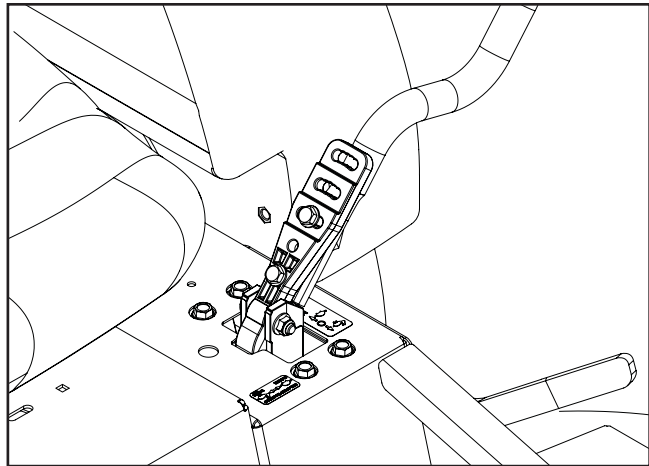

8061-020

*Place controls in neutral position to stop*

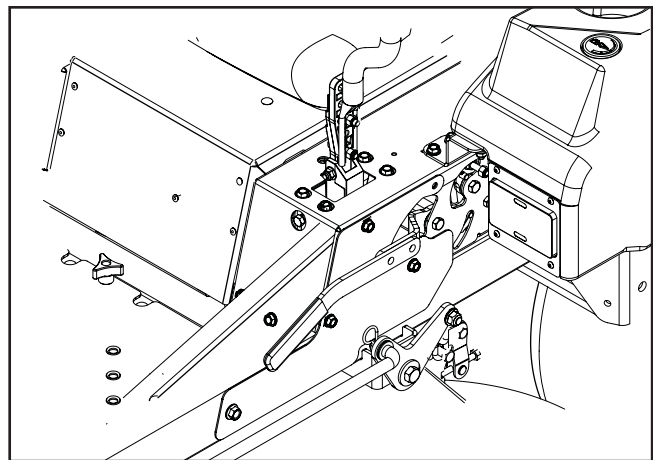

8061-019

*Released parking brake*

# OPERATION

## Mowing Tips

- Observe and flag rocks and other fixed objects to avoid collisions.
- Begin with a high cutting height and reduce it until the desired mowing result is attained. The average lawn should be cut to 2½" (64 mm) during the cool season and over 3" (76 mm) during the hot months. For healthier and better looking lawns, mow often after moderate growth. For best cutting performance, grass over 6" (15 cm) in height should be mowed twice. Make the first cut relatively high, the second to the desired height.
- The mowing result will be best with a high engine speed (the blades rotate rapidly) and low speed (the rider moves slowly). If the grass is not too long and dense, the driving speed can be increased without negatively affecting the mowing result.
- The finest lawns are obtained by mowing often. The lawn becomes more even and the grass clippings more evenly distributed over the mown area. The total time taken is not increased as a higher operating speed can be used without poor mowing results.
- Avoid mowing wet lawns. The mowing result is poorer because the wheels sink into the soft lawn, clumps build, and the grass clippings fasten under the cowling.
- Hose the mower deck underside with water after each use. When cleaning, the mower deck shall be raised into the transport position. Make sure the mower is cooled and the engine is off.
- Use compressed air to clean top surface of the deck. Avoid flooding water on top surface, engine and electrical components.
- When the mulching kit is used, it is important that the mowing interval is frequent.



### WARNING!

**Clear the lawn of stones and other objects that can be thrown out by the blades.**

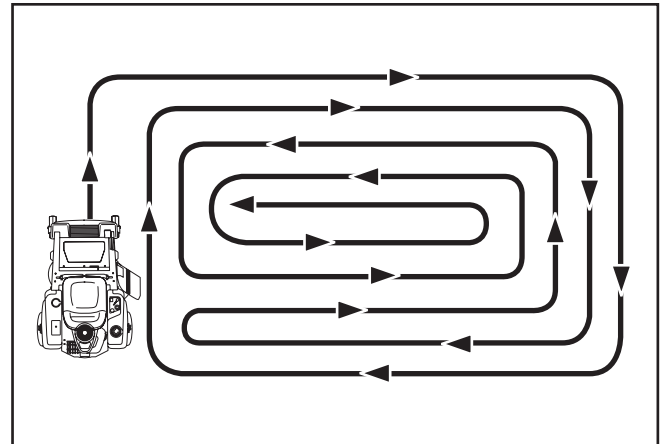

8011-603

*Mowing pattern*



### WARNING!

**Never drive the rider on terrain that slopes more than 10 degrees. Mow slopes up and down, never side to side. Avoid sudden directional changes.**

# OPERATION

## Stopping the Engine

Allow the engine to idle a minute in order to attain normal operating temperature before stopping it, if it has been worked hard. Avoid idling the engine for longer periods, as there is a risk of the spark plugs fouling.

- Disengage the mower deck by depressing the blade switch.

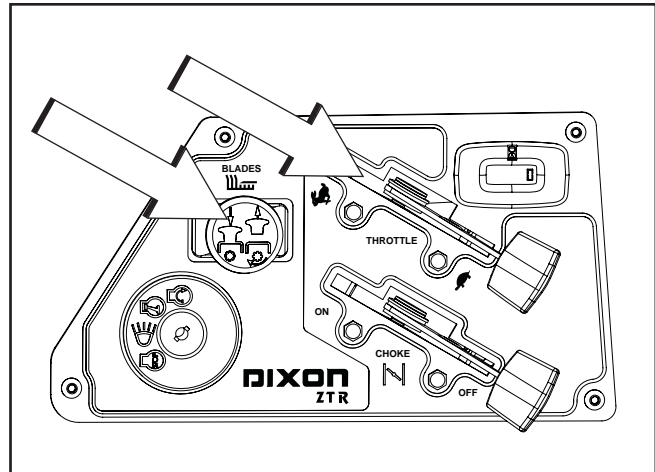

8061-017

*Disengage the mower deck and move throttle to minimum*

- Raise the mower deck by pressing the foot pedal forward to the transport position.
- When the machine is standing still, activate the parking brake by pulling the lever upward.
- Move the throttle to the minimum position (tortoise symbol). Turn the ignition key to the stop position.

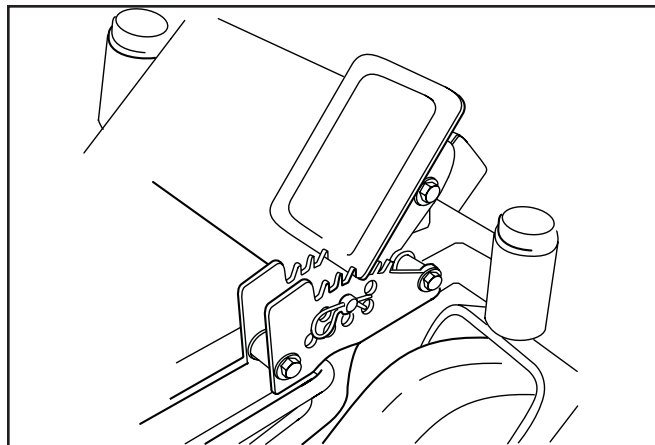

8050-117

*The mower deck's lifting lever*

- Move the steering controls outward.
- Remove key. Always remove key when leaving the mower to prevent unauthorized use.

### IMPORTANT INFORMATION

**Leaving the ignition switch in any other position than "OFF" will cause the battery to be discharged and the hour meter to accumulate hours.**

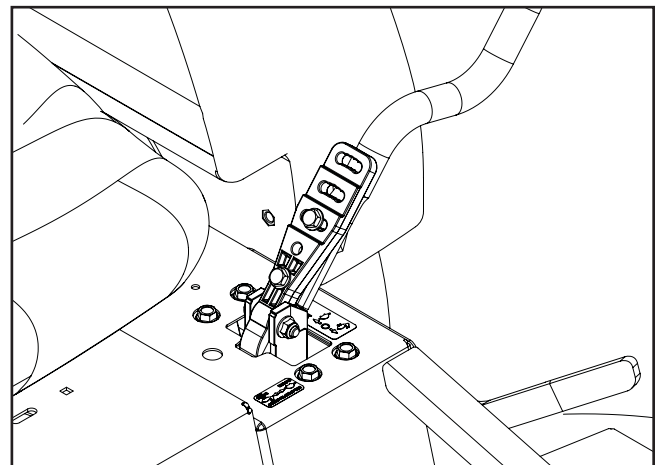

8061-020

*Place controls in neutral position to stop*



# OPERATION

## Moving by Hand

### **IMPORTANT INFORMATION**

**Tighten the valve moderately.**

**Do not overtighten the valve when closing.  
That can damage the valve seat.**

### **Pump release valves**

Pump release valves are located at the front and rear of the pump. They are used to release the system so the machine may be moved by hand when not running. Tilt seat forward to gain access to the pump. The rear bypass valve sits directly opposite the front valve, below the seat support. It is not visible in the illustration.

Use a 17 mm open end wrench or socket and ratchet. Turn the outer locknut 2-3 turns. Using an 8mm wrench or socket, turn the inner nut one turn.

Reverse the procedure to reset the pump.

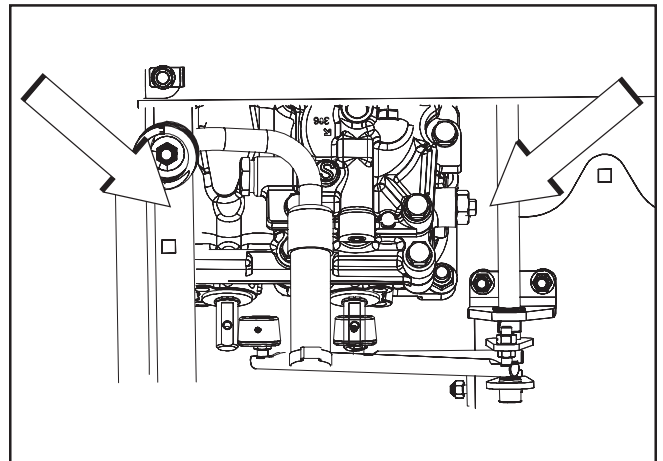

*Pump release valve*

8011-507

# MAINTENANCE

## Maintenance Schedule

The following is a list of maintenance procedures that must be performed on the machine. For those points not described in this manual, visit an authorized service workshop. An annual service carried out by an authorized service workshop is recommended to maintain your machine in the best possible condition and to ensure safe operation.

Read "Maintenance" in the Safety Instructions section.

<sup>1)</sup> First change after 5-8 hours. When operating with a heavy load or at high ambient temperatures, replace every 50 hours. <sup>2)</sup> In dusty conditions, cleaning and replacement are required more often. <sup>3)</sup> For daily use, the machine should be lubricated twice weekly. <sup>4)</sup> Performed by authorized service workshop.

● = Described in this manual

○ = Not described in this manual

Maintenance	Daily		Weekly	At least once each year	Maintenance interval in hours			
	Before	After			25	50	100	300
Check the parking brake	●							
Check the engine's oil level (every refueling)	●							
Check the safety system	●							
Check for fuel and oil leakages	○							
Check/clean the engine's cooling air intake		●						
Check the mower deck		●						
Check for loose hardware (screws, nuts)		●						
Clean under the mower deck		●						
Start the engine and blades, listen for unusual sounds		○						
Check for damage		○						
Thoroughly clean around the engine		○						
Clean around belts, belt pulleys		○						
Check the tire pressures						●		
Check battery						●		
Sharpen/Replace mower blades						●		
Clean the engine's cooling air intake <sup>2)</sup>				●	●			
Clean the air cleaner's pre-filter <sup>2)</sup> (foam)				●	●			
Clean the air cleaner's filter cartridge <sup>2)</sup> (paper filter)				●		●		
Check/adjust the parking brake				○		○		
Inspect muffler/Spark arrester				○		○		

# MAINTENANCE

Maintenance	Daily		Weekly	At least once each year	Maintenance interval in hours			
	Before	After			25	50	100	300
Check/adjust throttle and choke cables				●			●	
Check the condition of belts, belt pulleys				●			●	
Change the engine oil <sup>1)</sup>				●		●		
Replace the engine oil filter				●			●	
Clean/replace the spark plugs				●			●	
Replace the fuel filter				●			●	
Replace the air filter (paper filter) <sup>2)</sup>				●			●	
Check the caster wheels (every 200 hours)							●	
Replace the air cleaner's pre-filter <sup>2)</sup> (foam)				●				
Check/adjust the mower deck				●				●
Check the engine valve clearance <sup>3)</sup>				○				○
Perform the 300-hour service <sup>3)</sup>				○				○
Lubricate according to Lubrication Schedule				●	●	●	●	●
Check hydraulic oil at reservoir			●					
Change hydraulic oil & filter (200 hours)					●		●	

<sup>1)</sup> First change after 5-8 hours. When operating with a heavy load or at high ambient temperatures, replace every 50 hours. <sup>2)</sup> In dusty conditions, cleaning and replacement are required more often. <sup>3)</sup> Performed by authorized service workshop.

- = Described in this manual
- = Not described in this manual



**WARNING!**

**Before performing any service or adjustment checklist**

- Engage the parking brake.
- Place the Blade-switch in the disengaged position.
- Turn the ignition switch to "OFF" position and remove the key.
- Make sure the blades and all moving parts have completely stopped.
- Disconnect the spark plug wire from all spark plugs and place the wire where it cannot come in contact with the plug.

# MAINTENANCE

## Battery

Your mower is equipped with a maintenance free battery and does not need servicing. However, periodic charging of the battery with an automotive type battery charger will extend its life.

- Keep battery and terminals clean.
- Keep battery bolts tight.
- Recharge at 6-10 amperes for 1 hour

## To clean battery and terminals

Corrosion and dirt on the battery and terminals can cause the battery to "leak" power.

1. Open the terminal access doors.
2. Disconnect BLACK battery cable first, then the RED battery cable and remove the battery from the machine.
3. Rinse the battery with plain water and dry.
4. Clean terminals and battery cable ends with wire brush until shiny.
5. Coat terminals with grease or petroleum jelly
6. Reinstall battery.

## Replacing battery

1. Lift seat and rotate forward.
2. Open terminal access doors
3. Using two ½" wrenches disconnect BLACK battery cable then RED battery cable.
4. Using a 7/16" wrench, remove the bolts on either side of the terminal guard and lift off guard.
5. Carefully remove the battery from the mower.
6. Install new battery with terminals in the same position as the old battery.
7. Reinstall battery terminal guard.
8. First connect RED battery cable to positive (+) battery terminal with hex bolt and hex nut.
9. Connect BLACK grounding cable to negative (-) battery terminal with remaining hex bolt and hex nut.
10. Close access doors.
11. Lower seat.



**Always use protective glasses when handling the battery.**

## IMPORTANT INFORMATION

**Do not attempt to open or remove caps or covers. Adding or checking level of electrolyte is not necessary.**

**Always use two wrenches for the terminal screws**



## WARNING!

**Do not short battery terminals by allowing a wrench or any other object to contact both terminals at the same time. Before connecting battery, remove metal bracelets, wristwatch bands, rings, etc.**

**Positive terminal must be connected first to prevent sparks from accidental grounding.**

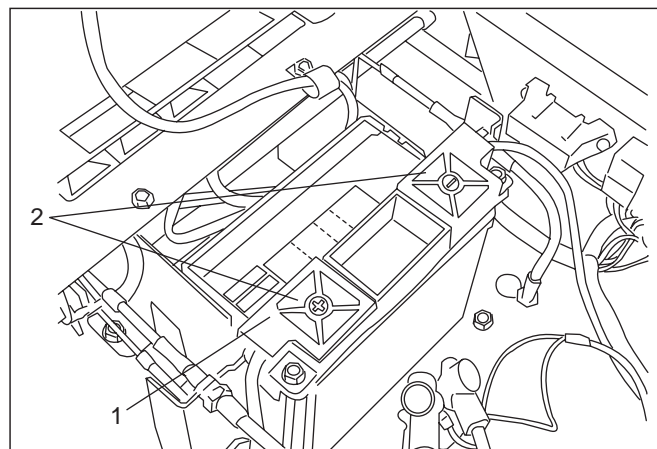

1. Terminal guard

2. Access doors

*Battery cleaning and installation*

CZ-22

# MAINTENANCE

## Ignition System

The engine is equipped with an electronic ignition system. Only the spark plugs require maintenance. For recommended spark plugs, see Technical Data.

1. Remove the ignition cable boot and clean around the spark plug.
2. Remove the spark plug with a spark plug socket wrench.
3. Check the spark plug. Replace the spark plug if fouled, the electrodes are burned and if the insulation is cracked or damaged. Clean the spark plug with a steel brush if it is to be reused.
4. Measure the electrode gap with a gapping tool. The gap should be .030" (0.75 mm). Adjust as necessary by bending the side electrode.
5. Reinsert the spark plug, turning by hand to avoid damaging the threads.
6. After the spark plug is seated, tighten it using a spark plug wrench so that the washer is compressed. A used spark plug should be turned  $\frac{1}{8}$  of a turn from the seated position. A new spark plug should be turned a  $\frac{1}{4}$  turn from the seated position.
7. Replace the ignition cable.

### IMPORTANT INFORMATION

**Fitting the wrong spark plug type can damage the engine.**

**Inadequately tightened spark plugs can cause overheating and damage the engine. Tightening the spark plugs too hard can damage the threads in the cylinder head.**

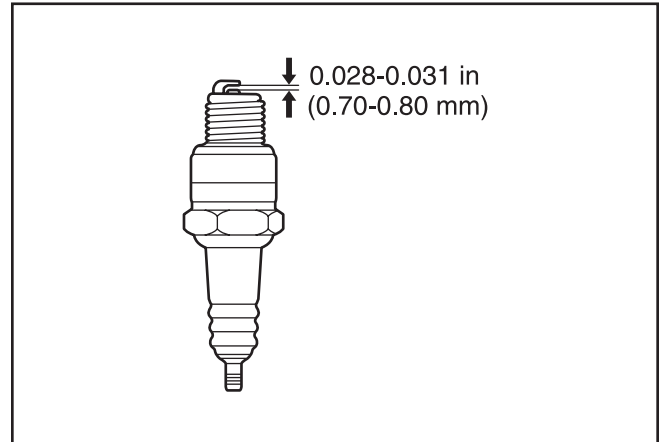

8011-054

Measure the electrode gap

## Safety System

The machine is equipped with a safety system that prevents starting or driving under the following conditions.

The engine can only be started when:

1. The mower deck is disengaged.
2. The steering controls are in the outer, locked neutral position.
3. The driver is sitting in the driver's seat.
4. The parking brake is on.

Make daily inspections to ensure that the safety system works by attempting to start the engine when one of the conditions is not met. Change the conditions and try again.

If the machine starts when one of these conditions is not met, turn the machine off and repair the safety system before using the machine again.

Make sure the engine stops when the park brake is not engaged and the operator leaves the seated position.

Check that the engine stops if the mower blades are engaged and the driver temporarily moves off the drivers seat.

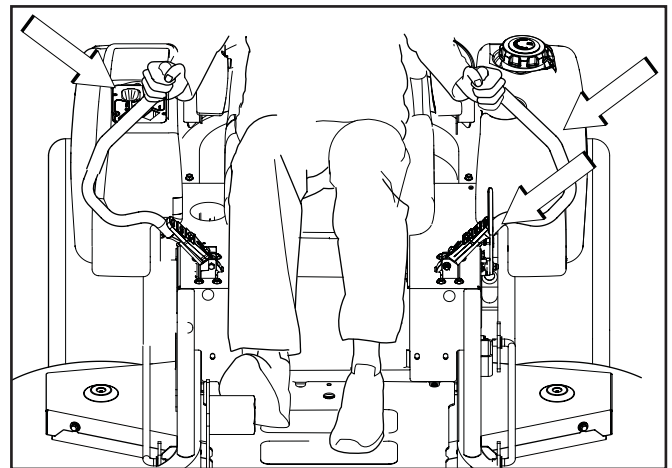

8061-018

Conditions for starting

### IMPORTANT INFORMATION

**In order to be able to drive, the driver must sit in the seat and release the parking brake before the steering controls can be moved into the neutral position, otherwise the engine will stop.**

English-37

# MAINTENANCE

## Engine Cooling Air Intake

Check that the engine's cooling air intake is free from leaves, grass, and dirt.

If the cooling air intake is clogged, engine cooling deteriorates, which can lead to engine damage.

The cooling air intakes rotates when the engine is running. Mind your fingers.

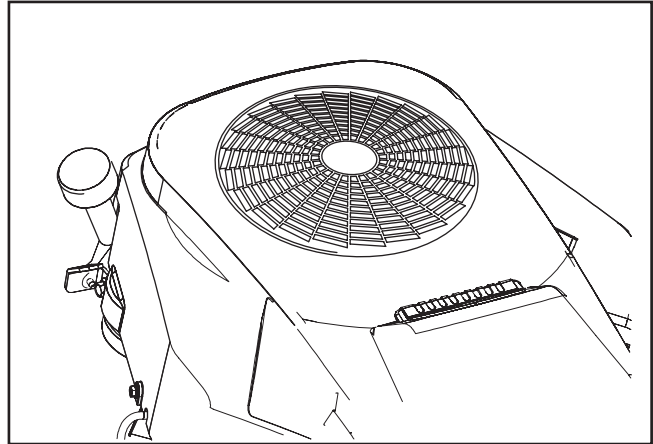

8061-014

*Check and clean the cooling air intake*

## Throttle Cable

Check that the engine responds to throttle increases and that a good engine speed is attained at full throttle.

If doubts arise, contact the service workshop.

If adjustments are necessary, they can be made as follows for the lower cable:

1. Loosen the clamping screw for the cable's outer casing and move the throttle to the full throttle position.
2. Check that the throttle cable is mounted in the correct hole in the lower lever, see illustration.
3. Push the throttle cable's outer casing as far to the right as possible and tighten the clamping screw.

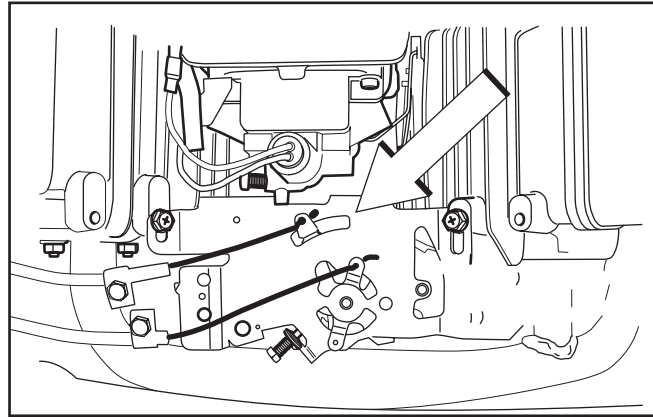

8011-605

*Adjusting the throttle cable*

## Choke Cable

If the engine produces black smoke or is difficult to start, this can be because the choke cable is incorrectly adjusted (upper cable).

If doubts arise, contact the service workshop.

If adjustments are necessary, they can be made as follows:

1. Loosen the clamping screw for the cable's outer casing and push the choke control fully in.
2. Check that the choke cable is mounted in the upper lever, see illustration. Push the choke cable's outer casing as far to the left as possible and tighten the clamping screw.

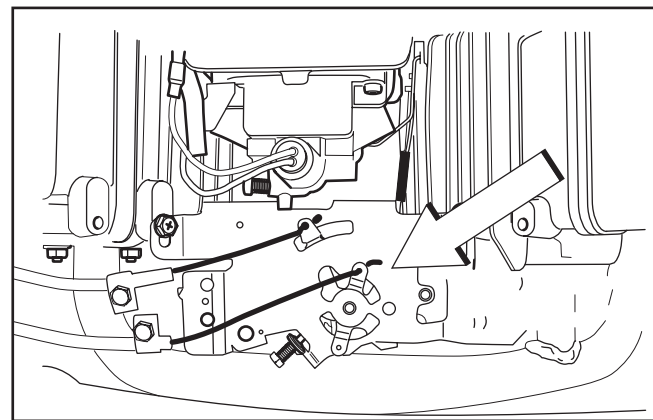

8011-605

*Adjusting the choke cable*

# MAINTENANCE

## Air Filter Maintenance

If the engine seems weak or runs unevenly, the air filter may be clogged. If running with a dirty air filter, the spark plugs can become fouled.

For this reason, it is important to replace the air filter regularly (see the heading Maintenance Schedule for the proper service interval).



### WARNING!

**The engine and the exhaust system become very hot during operation. Risk for burns if touched.**

**Allow engine and exhaust system to cool at least two (2) minutes.**

### IMPORTANT INFORMATION

**Do not use compressed air to clean the air filter.**

**Do not wash the paper filter.**

**Do not oil the paper filter.**

**Do not tap filter to clean this could cause damage to the sealing.**

## Replacing Air Filter

The engine is equipped with a replaceable, high density paper air cleaner element and an oiled, foam precleaner which surrounds the paper element.

Check the air cleaner daily or before starting the engine. Check for a buildup of dirt and debris around the air cleaner system. Keep this area clean. Also check for loose or damaged components. Replace all bent or damaged air cleaner components.

### IMPORTANT INFORMATION

**Operating the engine with loose or damaged air cleaner components could allow unfiltered air into the engine causing premature wear and failure.**

## Servicing Precleaner:

Wash and re-oil the precleaner every **25 hours** of operation (more often under extremely dusty or dirty conditions). Replace the precleaner **annually, or every 100 hours**.

1. Open the door on the blower housing to access the air cleaner element and precleaner.
2. Unhook the latch and remove the precleaner from the air cleaner element, or remove as an assembly for servicing. Make sure the base and the sealing area is clean before reassembly is performed.
3. Wash the precleaner in warm water with detergent. Rinse the precleaner thoroughly until all traces of detergent are eliminated. Squeeze out excess water (do not wring). Allow the precleaner to air dry.
4. Saturate the precleaner with new engine oil. Squeeze out all excess oil.
5. Reinstall the precleaner over the paper element and secure with the latch.
6. Close and latch the door.

## Servicing Paper Element:

Check the paper element **every 50 hours** of operation, (more often under extremely dusty or dirty conditions). Clean or replace the element as necessary. Replace the air cleaner element **annually, or every 100 hours**.

1. Open the door on the blower housing to access the air cleaner element.
2. Unhook the latch and remove the air cleaner element and precleaner.
3. Remove the precleaner (if so equipped) from the paper element. Service the precleaner as described in Precleaner Service.
4. Gently tap the paper element to dislodge dirt. **Do not wash the paper element or use pressurized air**, as this will damage the element. Replace a dirty, bent, or damaged element with a new one. Handle the new element carefully; do not use if the sealing surfaces are bent or damaged.
5. Clean the air cleaner base as required and check condition.
6. Reinstall the precleaner over the paper air cleaner element and install on the base. Secure with the latch.
7. Close and latch the door.

---

# MAINTENANCE

---

## Replacing the Fuel Filter

Replace the line-mounted fuel filter every 100 hours (once per season) or more regularly if it is clogged.

Replace the filter as follows:

1. Move the hose clamps away from the filter. Use flat-nosed pliers.
2. Pull the filter loose from the hose ends.
3. Push the new filter into the hose ends. Position the filter with the "FLOW" arrow pointing up toward the fuel pump. If necessary, a soap solution can be applied to the filter ends to ease mounting.
4. Move the hose clamps back toward the filter.

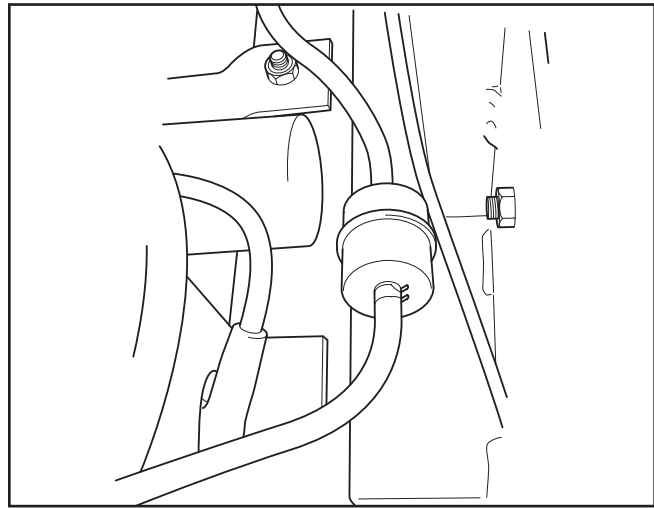

*Fuel filter*

8011-468

## Fuel Pump Air Filter

Regularly check that the fuel pump's air filter is free from dirt.

Remove the screws and open the pump, no hoses need be removed.

The filter can be cleaned with a brush if necessary.

Replace the filter on the console.

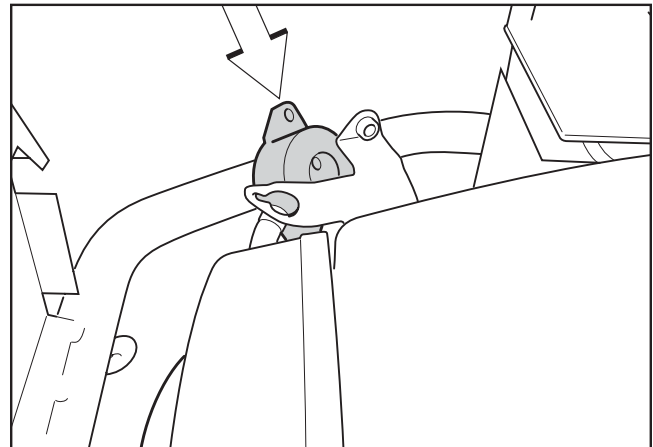

*The fuel pump's air filter*

8009-147



# MAINTENANCE

## Tire Pressures

Rear tires should have a pressure of 10 psi / 69 kPa / .7 bar. Front tires should be at 15 psi / 103 kPa / 1 bar.

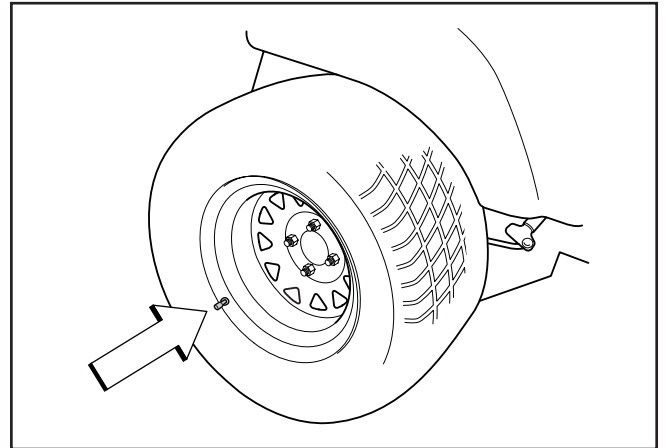

8011-564

*Tire pressures*

## Parking Brake

Visually check that no damage is found on the lever, cables, or switch belonging to the parking brake. Perform a standstill test and check that there is sufficient braking action.

To adjust the parking brake, contact the Dixon service workshop.



### **WARNING!**

**Faulty adjustment will result in reduced braking ability and can cause an accident.**

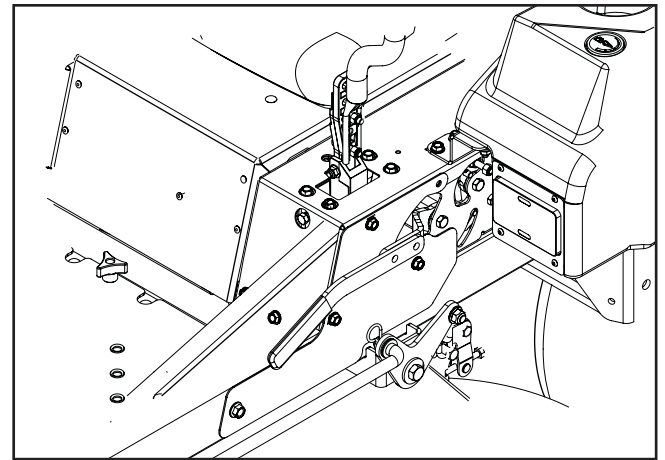

8061-019

*Parking brake*

## V-belts

Check every 100 hours of operation. Check for severe cracking and large nicks.

NOTE: The belt will show some small cracks in normal operation.

The belts are not adjustable. Replace belts if they begin to slip from wear.

### **IMPORTANT INFORMATION**

**The machine must be absolutely standing still when applying the parking brake.**

# MAINTENANCE

## Deck belt removal

1. Park on a level surface. Apply parking brake.
2. Lower the deck into the lowest cutting position.
3. Remove bolts from belt shields and remove shields.
4. Remove any dirt or grass that may have accumulated around the cutter housings and entire deck surface.
5. Carefully roll the belt over the top of the cutter housing pulleys and remove belt.

## Deck belt installation

*NOTE: For ease in installing the deck belt, refer to the routing decal on bottom of seat.*

1. Wrap the deck belt around the electric clutch pulley that is located on the engine shaft.
2. Route the belt forward between the EZT (E-Series Zeroturn Transaxles) and up onto the deck.
3. Place belt around spring loaded idler pulley.
4. Wrap the belt around the stationary idler pulley and around the mandrel housings.
5. Push inward on the idler arm and carefully route belt over stationary idler pulley. Once belt is properly routed, slowly release idler arm to tension belt.
6. Double check belt routing to make sure it matches the routing decal, and the belt does not have any twist. Correct as needed.
7. Adjust tension with deck eyebolt.
8. Replace belt shields on both mandrel housings and secure with fasteners.

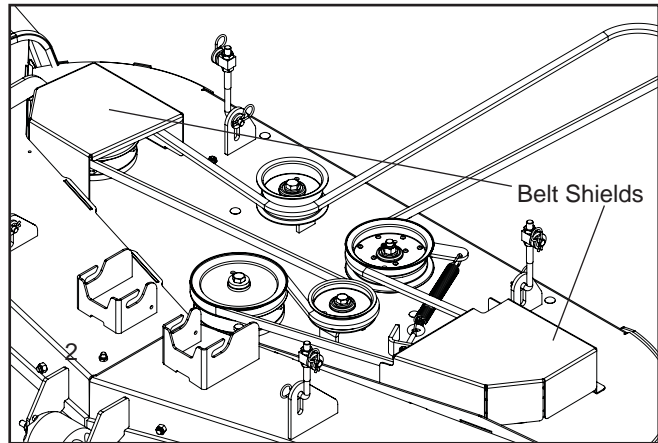

front deck2

Removing deck belt

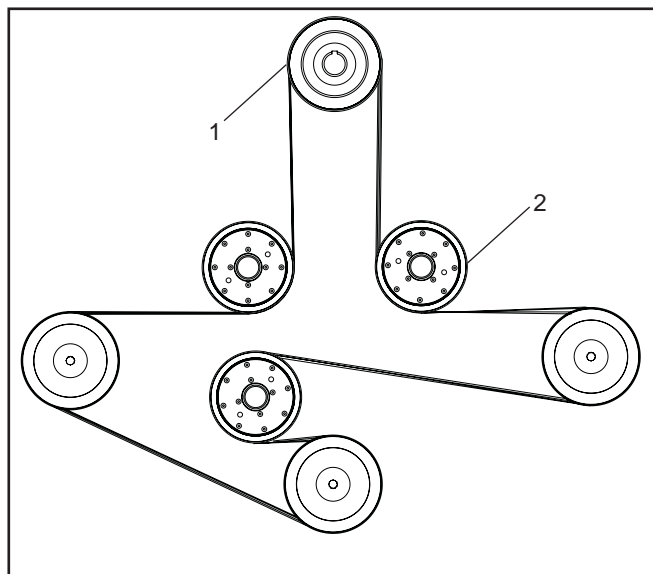

8061-021

1. Clutch pulley

2. Deck belt

Belt routing, deck belt

# MAINTENANCE

## Pump Belt

### Replacing pump belt

Park the mower on a level surface. Engage the parking brake.

### Belt removal

1. Remove the deck belt (see Deck Belt Removal in this section of the manual).
2. Remove clutch stop to access the belt.
3. Disconnect clutch wire.
4. Create slack in the belt by removing the spring on the pump idler arm.
5. The belt should now be able to be removed from the engine pulley and pump pulleys.

### Belt installation

1. Wrap the belt around the pulley
2. Route the belt around the inside of the idler pulley.
3. Wrap the belt around the engine pulley.
4. Reattach the spring on the pump idler arm.
5. Reconnect clutch wire.
6. Replace and secure clutch stop.
7. Reinstall the deck belt. (see Deck Belt Removal in this section of the manual).

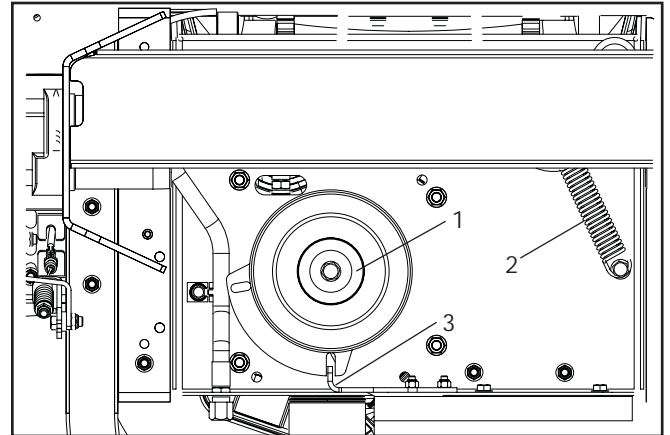

8054-002

1. Electric clutch
2. Idler spring
3. Clutch stop

*Pump belt removal*

## Cutting Blades

In order to attain the best mowing effect, it is important that the blades are well sharpened and not damaged.

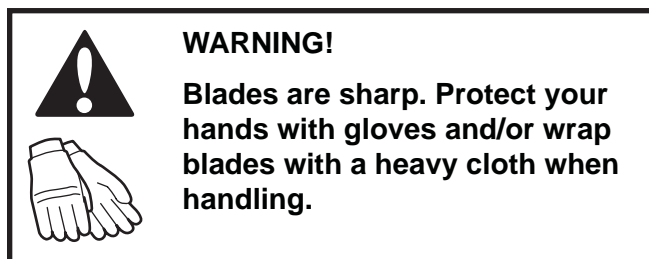

### WARNING!

**Blades are sharp. Protect your hands with gloves and/or wrap blades with a heavy cloth when handling.**

Bent or cracked blades or blades with large nicks should be replaced.

Damaged blades should be replaced when hitting obstacles that result in a breakdown. Let the service workshop decide whether the blade can be repaired/ground or must be replaced.

Balance the blades after sharpening.

Check the blade mounts.

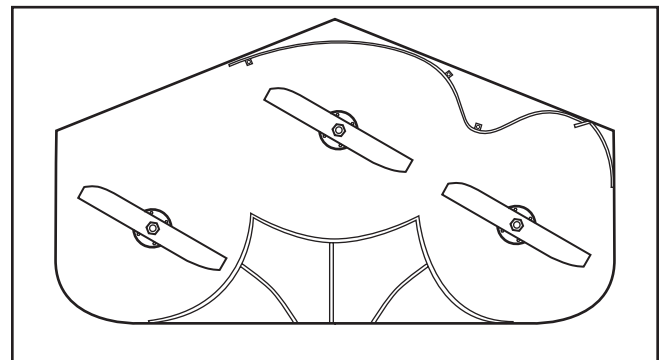

8011-604

*Check the blades*

### IMPORTANT INFORMATION

**The sharpening of blades should be carried out by an authorized service workshop.**

# MAINTENANCE

## Blade replacement



### WARNING!

Blades are sharp. Protect your hands with gloves and/or wrap blades with a heavy cloth when handling.

- Remove blade bolt by turning counterclockwise.

### IMPORTANT INFORMATION

To ensure proper assembly, center hole in blade must align with star on cutter housing.

- Install new or resharpened blade with stamped "GRASS SIDE" facing towards ground/grass (down) or "THIS SIDE UP" facing deck and cutter housing.
- Install and tighten blade bolt securely.
- Torque blade bolt to 45-55 ft/lbs (60-75 Nm).

### IMPORTANT INFORMATION

Special blade bolt is heat treated.

Replace with a Dixon bolt if required.

Do not use lower grade hardware than specified.

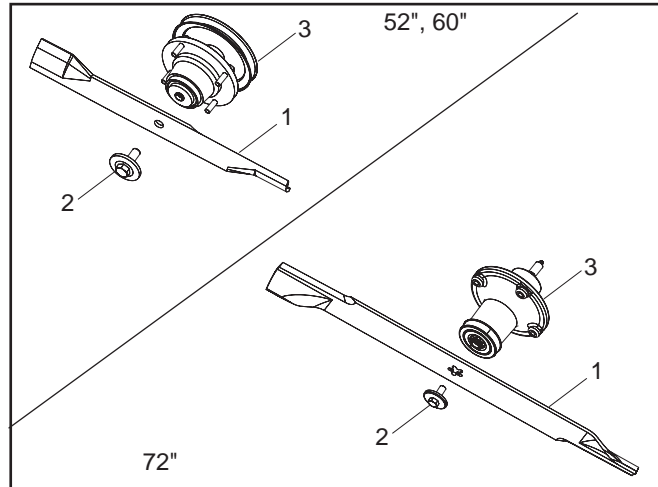

1. Blade
  2. Blade bolt (special)
  3. Cutter housing
- Blade attachment*

# MAINTENANCE

## Adjusting the Mower Deck



### WARNING!

Before performing any service or adjustment checklist:

1. Engage the parking brake.
2. Place the Blade switch in the disengaged position.
3. Turn ignition switch to "OFF" position and remove the key.
4. Make sure the blades and all moving parts have completely stopped.
5. Disconnect the spark plug wire from all spark plugs and place the wire where it cannot come in contact with the plug.

Check the tire pressure before adjustment of the mower deck. See "Checking Tire Pressure" in Maintenance section. Faulty mower deck adjustments will cause an uneven mowing result.

### Leveling deck

1. Position the mower on a level, preferably concrete, surface.
2. Check the pressure in all four tires. See "Technical Data".
3. Rotate blades to align front to back.
4. Set the cutting height to 4" (10cm).
5. Measure front blade tip. It should be 4" from ground. If not, turn locknut on top of front L bolt until measurement is achieved. Check blade tip at front on opposite front blade. Adjust locknut on front L bolt as necessary.
6. Check that the rear blade measurement is 4¼" (11.4cm) from ground. If not, turn locknut on top of rear L bolt to achieve measurement. Repeat procedure on opposite side.

### Adjusting Cutting Height

1. Raise and secure the deck height lever to the transport position (4½" / 11.5cm).
2. Position blade tip so it is straight forward.
3. Measure from the cutting edge of the blades to a flat level surface. The distance should be 4½" (11.4cm).
4. Drop the level to (for example) the 2" (5cm) cutting height. Measure as above. Distance should be 2".

NOTE: This will place the mower deck in a base measurement position. Additional adjustment may be required to achieve desired cut for the type of grass or conditions being mowed.



### WARNING!

Blades are sharp. Protect your hands with gloves and/or wrap blades with a heavy cloth when handling.

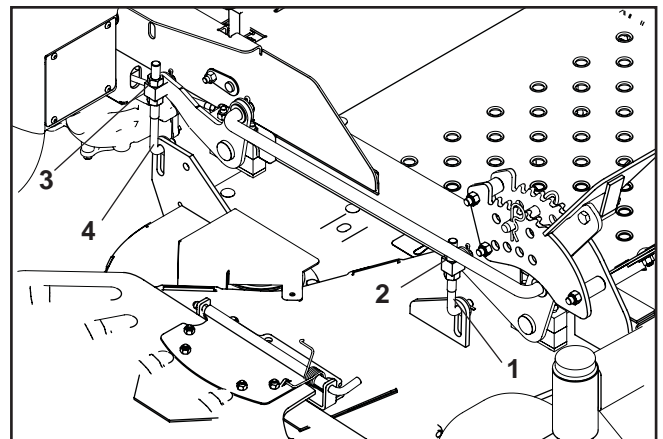

8050-808

1. Front L bolt
  2. Front locknut
  3. Rear locknut
  4. Rear L bolt
- Leveling the mower deck*

# MAINTENANCE

## Anti-scalp rollers

**Anti-scalp rollers** are properly adjusted when they are just slightly off of the ground when the deck is at the desired cutting height in the operating position.

**Anti-scalp rollers** then keep the deck in the proper position to help prevent scalping in most terrain conditions.

### IMPORTANT INFORMATION

**Adjust anti-scalp rollers with the mower on a flat level surface.**

The **anti-scalp rollers** can be set in three positions:

- Upper position 1½ to 3" (38 to 76 mm) grass.
- Middle position 3" to 4½" (76 to 114 mm) grass.
- Lower position 4½" to 6" (114 to 152 mm) grass.

The rollers should be approximately ¼" (6.5 mm) from ground. Do not adjust the rollers to support the deck.

### IMPORTANT INFORMATION

**The anti-scalp rollers must not be used for gauge wheels or the roller and deck may be damaged.**

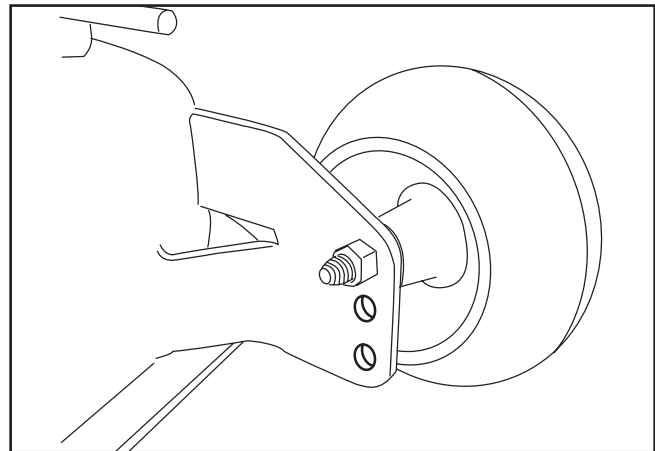

CZ-9

**Anti-scalp rollers**

# MAINTENANCE

## Cleaning and Washing

Regular cleaning and washing, especially under the mower deck, will increase the machine's life-span. Make it a habit to clean the machine directly after use (after it is cooled), before the dirt sticks.

Do not spray water on the top of the mower deck. Use compressed air to clean the top side of mower deck. Regularly clean deck and underside of the deck with normal water pressure. Do not use a high pressure washer or steam cleaner. Avoid spraying engine and electrical components with water



**Use protective glasses when cleaning and washing.**

Do not rinse hot surfaces with cold water. Let unit cool before washing.

## Caster Wheels

Check every 200 hours. Check that wheels rotates freely. If wheels do not rotate freely take the unit to your dealer for service.

### IMPORTANT INFORMATION

**DO NOT add any type of tire liner or foam fill material to the tires. Excessive loads created by foam filled tires will cause premature failures.**

**Only use O.E.M. specified tires.**

Foam filled tires or solid tires will void the warranty.

### Removal and installation of caster wheel

Remove nut and caster bolt.

Pull the wheel out of the fork and take care of the sleeve.

Install in reverse order. Tighten caster bolt.

## Hardware

Check daily. Inspect the entire machine for loose or missing hardware.

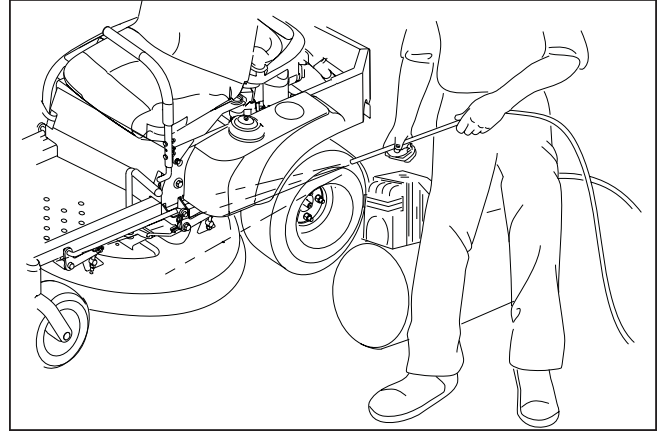

8050-092

*Clean regularly*

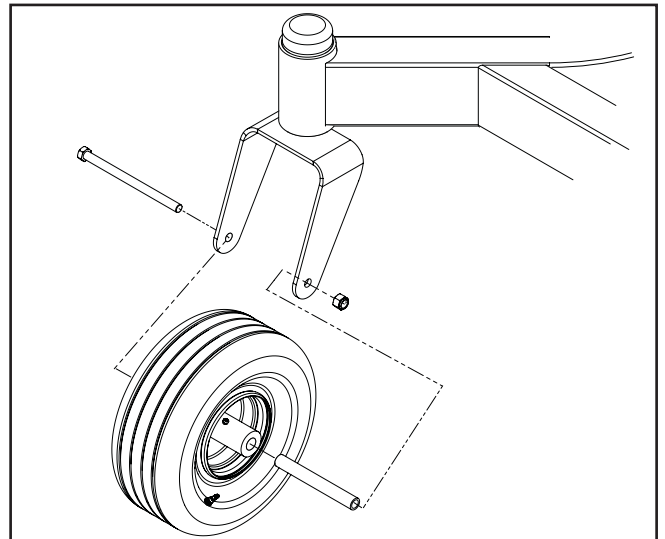

8011-619

*Caster wheels*

# LUBRICATION

12/12	1/52	1/365		25h	50h	100h	200h	300h
				1 ← (2x)				
				2 ← (2x)				
				3 ←				
				4 ← (2x)				
(Y)	👁️	5		*				
				6				

8011-672-6

12/12 Every year	Lubricate with grease gun		Lubricate with oil can	
1/52 Every Week	Oil change		Level check	
1/365 Every day	Filter change			

- **\*Change transaxles (transmission) filters.**

## General

Remove the ignition key to prevent unintentional movements during lubrication.

When lubricating with an oil can, it must be filled with engine oil.

When lubricating with grease, unless otherwise stated, use a high grade molybdenum disulphide grease.

For daily use, the machine should be lubricated twice weekly.

Wipe away excess grease after lubrication.

It is important to avoid getting lubricant on the belts or the drive surfaces on the belt pulleys. Should this happen, attempt to clean them with spirits. If the belt continues to slip after cleaning, it must be replaced. Gasoline or other petroleum products must not be used to clean belts.



# LUBRICATION

## Lubricating the Cables

If possible, grease both ends of the cables and move the controls to end stop positions when lubricating.

Refit the rubber covers on the cables after lubrication.

Cables with sheaths will bind if they are not lubricated regularly. If a cable binds, it can disrupt operation.

If a cable binds, remove the cable and hang it vertically. Lubricate it with light engine oil until the oil begins to escape from the bottom.

Tip: Fill a small plastic bag with oil and tape it so that it seals against the sheath and allow the cable to hang vertically from the bag overnight. If you do not succeed in lubricating the cable, it must be replaced.

## 1. Front Wheel Mount

Lubricate with a grease gun, one zerk for each wheel mount, until the grease is forced out.

Use only good quality bearing grease.

Grease from well-known brand names (petrochemical companies) usually maintains a good quality.

## 2. Front Wheel Bearings

Lubricate with a grease gun, one zerk for each set of wheel bearings, until the grease is forced out.

Use only good quality bearing grease.

## 3. Deck spindle

Lower the cutting deck completely.

If you use grease gun without rubber hose, the foot plate must be removed.

Lubricate with a grease gun, one zerk, 2-3 strokes.

Use only good quality bearing grease.

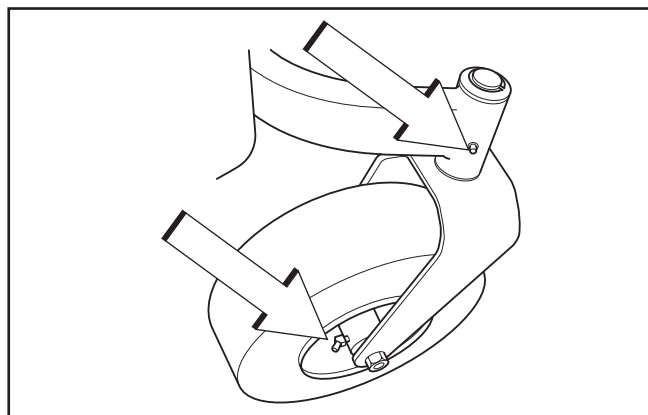

8011-731

*Lubricating the front wheels*

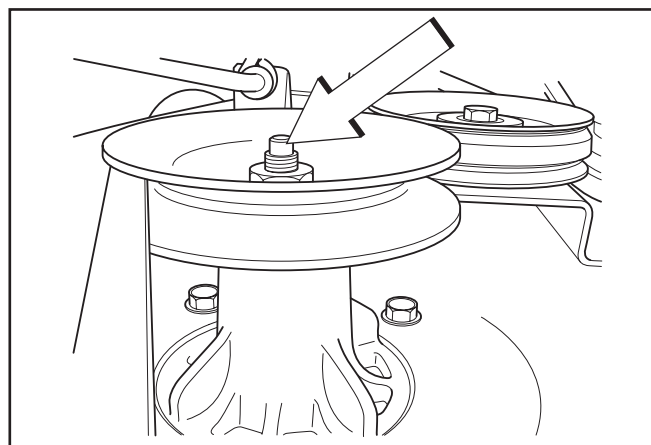

8011-732

*Deck spindle*

### IMPORTANT INFORMATION

**Use minimal lubrication and remove excess lubricant so that it does not come into contact with belts or belt pulley drive surfaces.**

# LUBRICATION

## 4. Deck outer spindle

Lubricate using a grease gun, one zerk, each side 2-3 strokes. Use only good quality bearing grease.

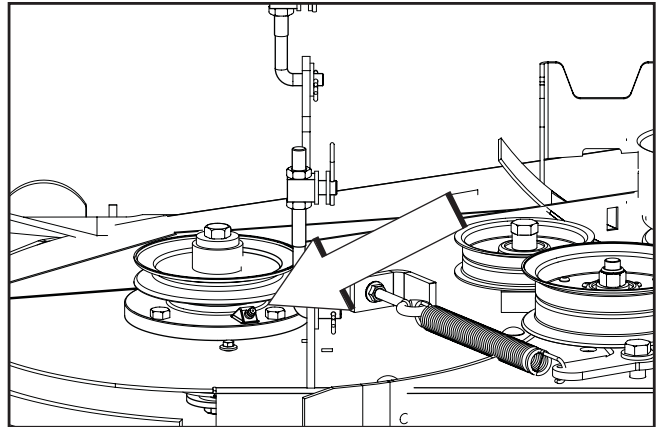

8011-733

*Deck outer spindle (with belt shield removed)*



### **WARNING!**

**Engine oil can be very hot if it is drained directly after stopping the engine. Allow the engine to cool to a safe temperature first.**

## Engine Oil

### 5. Engine Oil Filter

- Drain the engine oil in accordance with the work description under the heading Engine Oil/Change Engine Oil.
- Remove the oil filter. If necessary, use a filter remover.
- Wipe new, clean engine oil onto the seal for the new filter.
- Mount the filter by hand with  $+3/4$  turn.
- Run the engine warm, then check that there are no leaks around the oil filter seal.
- Check the oil level in the engine, fill if necessary. The oil filter holds 0.1 qt (0.1 liters) of oil.

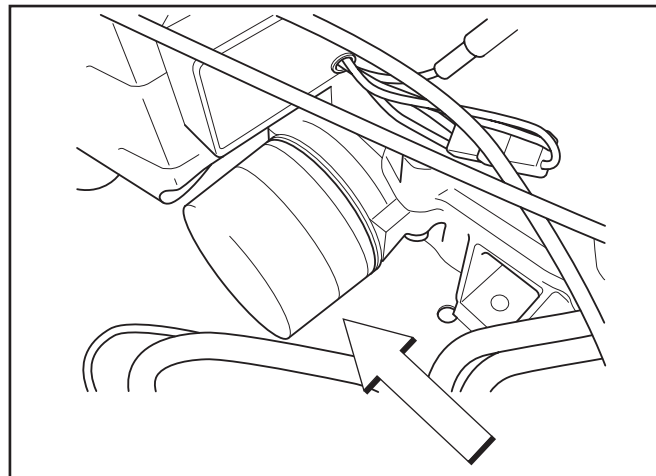

*Changing the oil filter*

8011-734

### **IMPORTANT INFORMATION**

**Used engine oil is a health hazard and must not be disposed of on the ground or in nature; it should always be disposed of at a workshop or appropriate disposal location.**

**Avoid skin contact; wash with soap and water in case of spills.**

# LUBRICATION



## WARNING!

Engine oil can be very hot if it is drained directly after stopping the engine. Allow the engine to cool to a safe temperature first.

## 5. Changing the Engine Oil

The engine oil should be changed for the first time after 5-8 hours of operation. Thereafter, it should be changed every 50 hours. The oil drain valve is located at the rear of the unit, to the right of the oil filter.

- Place the machine on a flat surface.
- Place a container under the engine where the oil drain valve exits.
- Remove the valve cap.
- Allow the oil to run out into the container.
- Reinstall the oil drain valve cap.
- Replace the oil filter if necessary.
- Fill with new engine oil in accordance with Checking the Oil Level.
- Start the engine. Run it for 3-5 minutes. Stop and recheck the oil level.

## 6. Engine Oil Levels

Check the oil level in the engine when the machine is standing level and the engine is stopped.

Remove the dipstick, wipe it clean, and then replace it. The dipstick should be screwed into place.

Take the dipstick out again and read the oil level.

The oil level should lie between the markings on the dipstick. If the level is approaching the "ADD" mark, fill the oil to the "FULL" mark on the dipstick.

Never fill to above the "FULL" mark.

The oil is filled through the hole for the dipstick.

API class SF, SG, SH, SJ or higher must be used. Synthetic oil SAE 5W-30 or 10W-30 is recommended at all temperatures. Mineral oil SAE 5W-30, 10W-30 can be used between

-18 °C/0 °F and +5 °C/40 °F. At temperature above +5 °C/40 °F single grade SAE 30 must be used.

The engine holds 0.88 qt (1.0 liters) of oil excluding the filter, including filter 2 qt (1.9 liters).

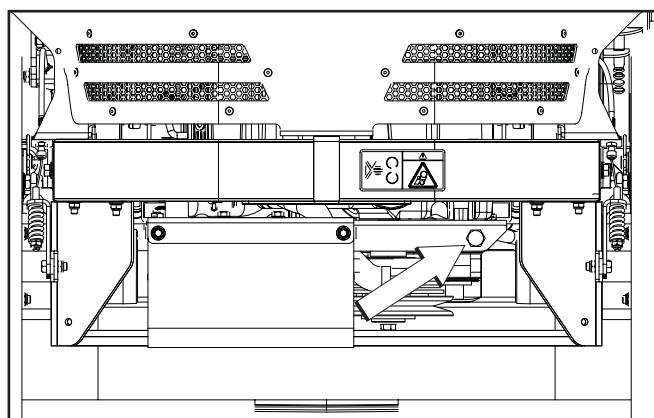

Oil drain valve

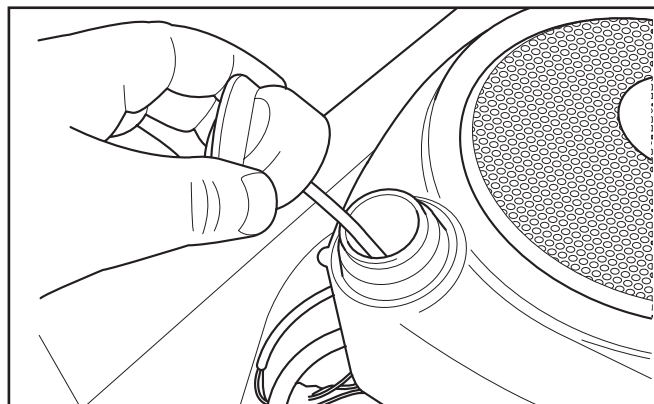

8011-500

Remove the dipstick

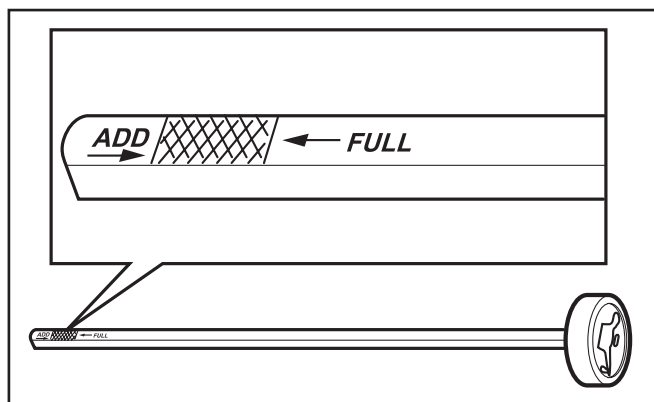

The dipstick markings

# LUBRICATION

## \*Hydraulic Pump

### Fluid Change

This transaxle is designed with an external filter for ease of maintenance. To ensure constant fluid quality levels and longer life an oil filter change interval of every **200 hours** is recommended.

The following procedure can be performed with the pump installed in the vehicle, and the vehicle on level ground. Apply the bypass valve and lock the vehicle parking brake.

1. Place an oil drain pan with a two gallon capacity beneath the oil filter. Remove the oil filter from the pump.
2. After the oil has drained, wipe the filter base surface off and apply a film of new oil to the gasket of the new replacement filter.
3. Install the new filter by hand, turn  $\frac{3}{4}$  to one full turn after the filter gasket contacts the filter base surface.
4. Drain old oil filters of all free-flowing oil prior to disposal. Place used oil in appropriate containers and dispose of it in accordance with laws in your area.
5. Remove the cap from the pump's expansion tank located on the vehicle frame.
6. Fill reservoir with SAE 10W30 oil to just above the MIN-ADD line on the reservoir. After purging, check levels and add oil if necessary.
7. Reinstall the tank cap by hand. Do not overtighten.
8. Proceed to the purge procedure.

### Purging Procedures

Due to the effects air has on efficiency in hydrostatic drive applications, it is critical that it is purged from the system.

These purge procedures should be implemented any time a hydrostatic system has been opened to facilitate maintenance or any additional oil has been added to the system.

The resulting symptoms in hydrostatic systems may be:

1. Noisy operation.
2. Lack of power or drive after short term operation.
3. High operation temperature and excessive expansion of oil.

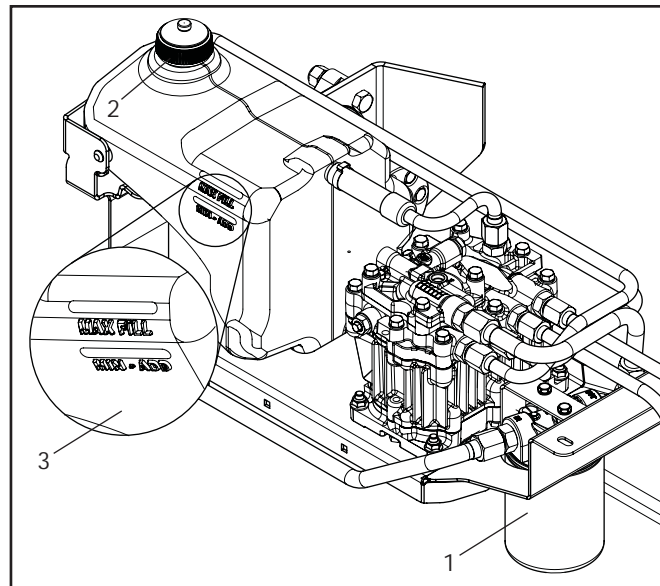

8061-016

1. Pump filter
2. Pump reservoir
3. Fluid fill lines

### Changing the hydraulic pump oil filter

Before starting, make sure the pump is at the proper oil level. If it is not, fill to the specifications outlined earlier.

The following procedures are best performed with the vehicle drive wheels off the ground, then repeated under normal operating conditions.

1. Disengage the brake if activated.
2. With the bypass valve open and the engine running at fast idle, slowly move the directional control in both forward and reverse directions (5 or 6 times). As air is purged from the unit, the oil level will drop.
3. With the bypass valve closed and the engine running, slowly move the directional control in both forward and reverse directions (5 to 6 times). Check the oil level, and add oil as required after stopping the engine.
4. It may be necessary to repeat Steps 2 and 3 until all the air is completely purged from the system. When the transaxle operates at normal noise levels and moves smoothly forward and reverse at normal speeds, then the transaxle is considered purged.
5. After the vehicle has been used two times, the oil level should be checked while the oil is cold and adjusted accordingly.

---

# TROUBLESHOOTING

---

<b>Problem</b>	<b>Cause</b>
The engine will not start.	<ul style="list-style-type: none"><li>• The blade switch is engaged.</li><li>• The steering controls are not locked in the neutral position.</li><li>• The driver is not sitting in the driver's seat.</li><li>• The parking brake is not activated.</li><li>• The battery is dead.</li><li>• Contamination in the carburetor or fuel line.</li><li>• The fuel supply is closed or the shutoff valve for the fuel tank is in the wrong position.</li><li>• Clogged fuel filter or fuel line.</li><li>• Ignition system faulty.</li></ul>
The starter does not turn the engine over.	<ul style="list-style-type: none"><li>• Dead battery.</li><li>• Poor contact of the battery terminal cable connections.</li><li>• Fuse blown.</li><li>• Fault in the starter safety circuit.</li></ul> <p>See Checking the Safety System in the "Maintenance Section"</p>
The engine runs rough.	<ul style="list-style-type: none"><li>• Faulty carburetor.</li><li>• The choke control is pulled out with a warm engine.</li><li>• Clogged fuel filter or jet.</li><li>• Clogged ventilation valve on the fuel cap.</li><li>• Fuel tank nearly empty.</li><li>• Fouled spark plugs.</li><li>• Rich fuel mixture or fuel-air mixture.</li><li>• Wrong fuel type.</li><li>• Water in the fuel.</li><li>• Clogged air filter.</li></ul>
The engine seems weak.	<ul style="list-style-type: none"><li>• Clogged air filter.</li><li>• Fouled spark plugs.</li><li>• Carburetor incorrectly adjusted.</li><li>• Air trapped in hydraulic system.</li></ul>
The machine vibrates.	<ul style="list-style-type: none"><li>• The blades are loose.</li><li>• The blades are incorrectly balanced.</li><li>• The engine is loose.</li></ul>

---

# TROUBLESHOOTING

---

<b>Problem</b>	<b>Cause</b>
The engine overheats.	<ul style="list-style-type: none"><li>• Clogged air intake or cooling fins.</li><li>• Engine overloaded.</li><li>• Poor ventilation around engine.</li><li>• Defective engine speed regulator.</li><li>• Too little or no oil in the engine.</li><li>• Fouled spark plugs.</li></ul>
Battery not charging.	<ul style="list-style-type: none"><li>• Poor contact with battery terminal cable connectors.</li><li>• Charging lead is disconnected.</li></ul>
The machine moves slowly, unevenly, or not at all.	<ul style="list-style-type: none"><li>• Parking brake on.</li><li>• Bypass valve on pump open.</li><li>• Drive belt for the transmission slack or has come off.</li><li>• Air trapped in hydraulic system.</li></ul>
Mower deck not engaging.	<ul style="list-style-type: none"><li>• Drive belt for the mower deck has come loose.</li><li>• Contact for the electromagnetic coupling has loosened.</li><li>• The blade switch is faulty or has come loose, from the cable contact.</li><li>• The fuse has blown.</li></ul>
Transaxle leaks oil.	<ul style="list-style-type: none"><li>• Damaged seals, housing, or gaskets.</li><li>• Air trapped in hydraulic system.</li></ul>
Uneven mowing results.	<ul style="list-style-type: none"><li>• Different air pressure in the tires on the left and right sides.</li><li>• Bent blades.</li><li>• The suspending for the mower deck is uneven.</li><li>• The blades are dull.</li><li>• Driving speed too high.</li><li>• The grass is too long.</li><li>• Grass collected under the mower deck.</li></ul>

---

# STORAGE

---

## Storage

### Winter Storage

At the end of the mowing season, the machine should be readied for storage (or if it will not be in use for longer than 30 days). Fuel allowed to stand for long periods of time (30 days or more) can leave sticky residues that can plug the carburetor and disrupt engine function.

Fuel stabilizers are an acceptable option as regards to the sticky residues that can occur during storage.

Add stabilizer to the fuel in the tank or in the storage container. Always use the mixing ratios specified by the manufacturer of the stabilizer. Run the engine for at least 10 minutes after adding the stabilizer so that it reaches the carburetor. Do not empty the fuel tank and the carburetor if you have added stabilizer



### **WARNING!**

**Never store an engine with fuel in the tank indoors or in poorly ventilated spaces where fuel vapor can come in contact with open flames, sparks, or a pilot light such as in a boiler, hot water tank, clothes dryer, etc. Handle the fuel with care. It is very flammable and can cause serious personal injury and property damage. Drain the fuel into an approved container outdoors and far away from open flame. Never use gasoline for cleaning. Use a degreaser and warm water instead.**

To ready the machine for storage, follow these steps:

1. Thoroughly clean the machine, especially under the mower deck. Touch up damage to the paint and spray a thin layer of oil on the underside of the mower deck to avoid corrosion.
2. Inspect the machine for worn or damaged parts and tighten any nuts or screws that may have become loose.
3. Change the engine oil; dispose of properly.
4. Empty the fuel tanks or add a fuel stabilizer. Start the engine and allow it to run until the carburetor is drained of fuel or the stabilizer has reached the carburetor.
5. Remove the spark plug and pour about a tablespoon of engine oil into the cylinder. Turn over the engine so that the oil is evenly distributed and then refit the spark plug.
6. Lubricate all grease zerks, joints, and axles.
7. Remove the battery. Clean, charge, and store the battery in a cool place, but protect it from direct cold.
8. Store the machine in a clean, dry place and cover it for extra protection.

### **Service**

When ordering spare parts, please specify the purchase year, model, type, and serial number.

Always use genuine Dixon spare parts.

An annual check-up at an authorized service workshop is a good way to ensure that your machine performs its best the following season.

# SCHEMATICS

- NOTES:  
 1. SEAT UNOCCUPIED  
 2. BRAKE SWITCH IN OFF POSITION  
 3. MOTION CONTROL LEVERS OUT  
 4. PTO IN OFF POSITION

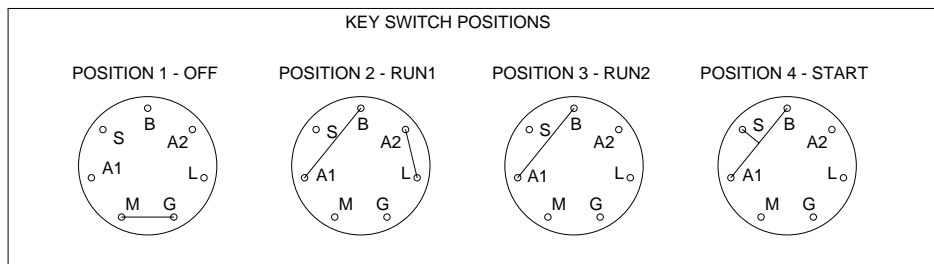
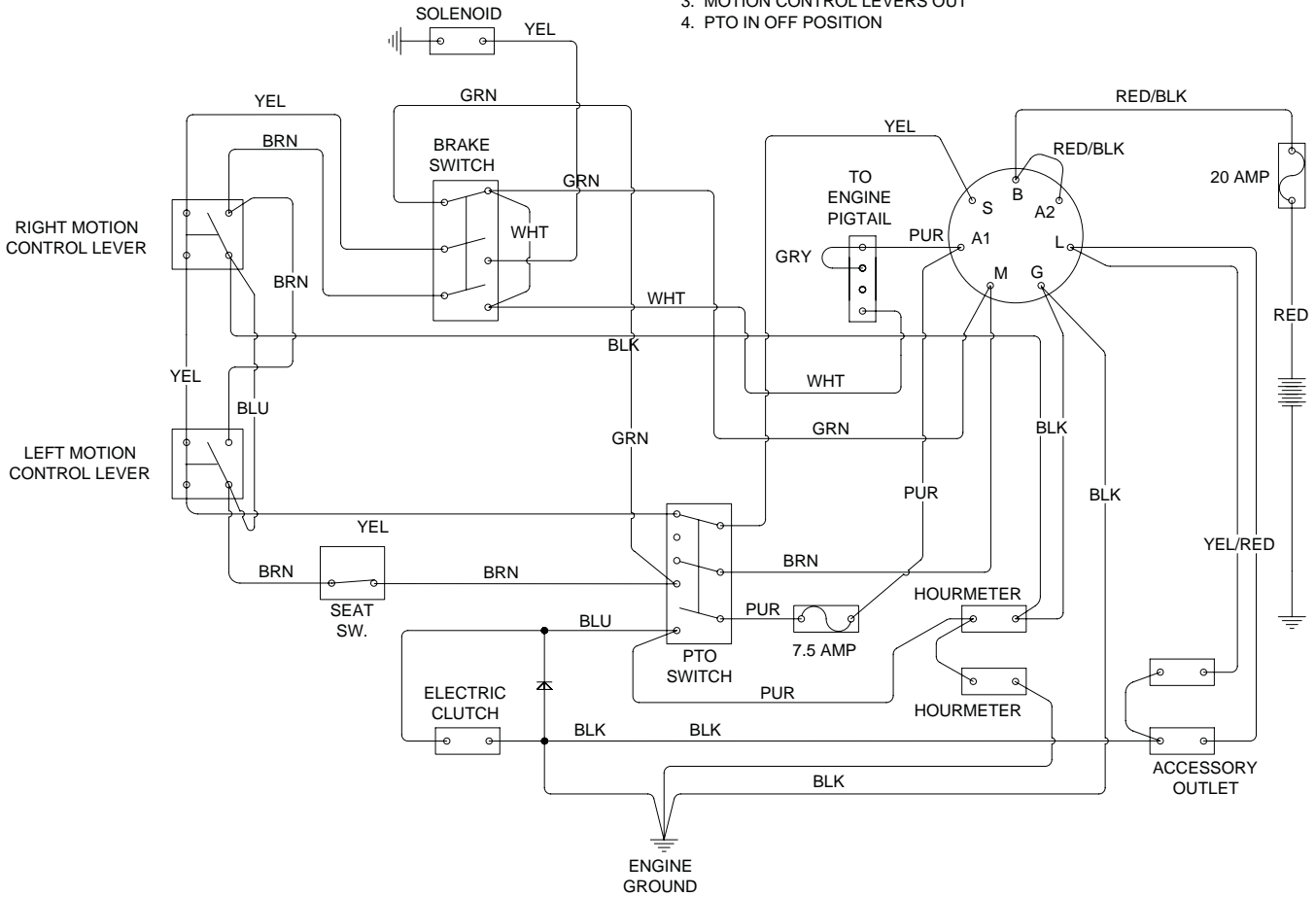



# TECHNICAL DATA

	Ram Xs5025 / 968999722	Ram Xs6025 / 968999723
<b>Engine</b>		
Manufacturer	Kohler	Kohler
Type	Courage Pro	Courage Pro
Power	25 hp*	25 hp*
Lubrication	Pressure with oil filter	Pressure with oil filter
Oil capacity excluding filter	1.6 qt / 1.7 liter	1.6 qt / 1.5 liter
Oil capacity including filter	1.7 qt / 1.9 liter	1.7 qt / 1.6 liter
Engine oil (See viscosity diagram)	10W30, 5W30 SG, SH, SJ	10W30, 5W30 SG, SH, SJ
Fuel	Min 87 octane unleaded (Max ethanol 10%, Max MTBE 15%)	Min 87 octane unleaded (Max ethanol 10%, Max MTBE 15%)
Fuel tank capacity	5.2 gallons / 19.7 liters	5.2 gallons / 19.7 liters
Spark plugs / gap	Champion RCY12YC .030" / 0.75 mm	Champion RCY12YC .030" / 0.75 mm
Cooling	Air cooled	Air cooled
Air filter	Standard	Standard
Alternator	12V	12V
Starter	Electric	Electric
<b>Transmission</b>		
Transmission		
Speed and direction controls	Dual levers, foam gripped	Dual levers, foam gripped
Speed forward	8 mph / 12.9 km/h	8 mph / 12.9 km/h
Speed reverse	4 mph / 6.45 km/h	4 mph / 6.45 km/h
Brakes	Mechanical parking brake	Mechanical parking brake
Front caster tires, smooth tread	13 x 5.0-6, 4 ply	13 x 5.0-6, 4 ply
Rear tires, turf pneumatic	23 x 10.5-12	23 x 10.5-12
Tire pressure, front	15 PSI / 103 kPa / 1 bar	15 PSI / 103 kPa / 1 bar
Tire pressure, rear	10 PSI / 69 kPa / .7 bar	10 PSI / 69 kPa / .7 bar

\*As rated by the engine manufacturer.

## TECHNICAL DATA

	<b>Ram Xs5025 / 968999722</b>	<b>Ram Xs6025 / 968999723</b>
Cutting Width	52" / 127cm	60" / 152cm
Cutting Height	1.5 - 4.5" / 3.8 - 11.4 cm	1.5 - 4.5" / 3.8 - 11.4 cm
Uncut Circle	0	0
Number of Blades	3	3
Blade Length	17" / 435 mm	20" / 510 mm
Nose Rollers	Yes	Yes
Sprung Seat	Standard	Standard
Hinged Arm Rests	Yes	Yes
Hour Meter	Standard	Standard
Blade Engagement	Electromagnetic clutch	Electromagnetic clutch
Deck Construction	11 gauge fabricated	11 gauge fabricated
<b>Productivity</b>		
Productivity	4.0 acres /h 16187 m <sup>2</sup> /h	4.8 acres /h 19425 m <sup>2</sup> /h
<b>Overall Dimensions</b>		
Weight	760 lbs / 345 kg	780 lbs / 354 kg
Base Machine Length	76" / 193 cm	76" / 193 cm
Base Machine Height	42" / 107 cm	42" / 107 cm
Overall Width, Chute Up	51" / 130 cm	61" / 155 cm
Overall Width, Chute Down	60" / 152 cm	72" / 183 cm

# TECHNICAL DATA

	<b>Ram Xs7227 / 968999724</b>
<b>Engine</b>	
Manufacturer	Kohler
Type	Courage Pro
Power	27 hp*
Lubrication	Pressure with oil filter
Oil capacity excluding filter	1.6 qt / 1.7 liter
Oil capacity including filter	1.7 qt / 1.9 liter
Engine oil (See viscosity diagram)	10W30, 5W30 SG, SH, SJ
Fuel	Min 87 octane unleaded (Max ethanol 10%, Max MTBE 15%)
Fuel tank capacity	5.2 gallons / 19.7 liters
Spark plugs / gap	Champion RCY12YC .030" / 0.75 mm
Cooling	Air cooled
Air filter	Standard
Alternator	12V
Starter	Electric
<b>Transmission</b>	
Transmission	
Speed and direction controls	Dual levers, foam gripped
Speed forward	8 mph / 12.9 km/h
Speed reverse	4 mph / 6.45 km/h
Brakes	Mechanical parking brake
Front caster tires, smooth tread	13 x 5.0-6, 4 ply
Rear tires, turf pneumatic	23 x 10.5-12
Tire pressure, front	15 PSI / 103 kPa / 1 bar
Tire pressure, rear	10 PSI / 69 kPa / .7 bar

\*As rated by the engine manufacturer.

---

## TECHNICAL DATA

---

	<b>7227 / 968999719</b>
Cutting Width	72" / 183cm
Cutting Height	1.5 - 4.5" / 3.8 - 11.4 cm
Uncut Circle	0
Number of Blades	3
Blade Length	25" / 635 mm
Nose Rollers	No
Sprung Seat	Standard
Hinged Arm Rests	Yes
Hour Meter	Standard
Blade Engagement	Electromagnetic clutch
Deck Construction	11 gauge fabricated
<b>Productivity</b>	
Productivity	5.8 acres /h 23472 m <sup>2</sup> /h
<b>Overall Dimensions</b>	
Weight	797 lbs / 362 kg
Base Machine Length	78" / 201 cm
Base Machine Height	42" / 107 cm
Overall Width, Chute Up	73" / 187 cm
Overall Width, Chute Down	87" / 221 cm

---

# TECHNICAL DATA

---

## Accessories

Collection system

## Torque Specifications

- Engine crankshaft bolt 50 ft/lb (67 Nm)
- Deck pulley bolts 45 ft/lb (61 Nm)
- Lug nuts 75 ft/lb (100 Nm)
- Blade bolt 45-55 ft/lb (60-75 Nm)
- Standard ¼" fasteners 9 ft/lb (12 Nm)
- Standard 5/16" fasteners 18 ft/lb (25 Nm)
- Standard 3/8" fasteners 33 ft/lb (44 Nm)
- Standard 7/16" fasteners 52 ft/lb (70 Nm)
- Standard ½" fasteners 80 ft/lb (110 Nm)

When this product is worn out and no longer used, it should be returned to the reseller or other party for recycling.

**In order to implement improvements, specifications and designs can be altered without prior notification.**

**Note that no legal demands can be placed based on the information contained in these instructions.**

**Use only original parts for repairs. The use of other parts voids the warranty.**

**Do not modify or install non-standard equipment to the unit without consent from the manufacturer. Modifications to the unit may cause unsafe operations or damage the unit.**

---

# CONFORMITY CERTIFICATES

---

## **Conformity Certificates**

### **USA requirements**

Labels are placed on the engine and/or in the engine compartment stating that the machine will fulfill the requirements. This is also applicable to special requirements for any of the states, (California emission rules etc.). Do not remove any of these labels. Certificates can also be supplied with the machine at delivery or written in the Engine manual. Take care of them as they are valuable documents.

### **CE requirements**

Vibration data corresponding to Directive 2002/44/EC is given in the Technical Data Section. The Declaration of Conformity is included in the literature packet.

# SERVICE JOURNAL

Action	Date, mtr reading, stamp, sign
<b>Delivery Service</b>	
1. Charge the battery.	<input type="checkbox"/>
2. Adjust the tire pressure of all wheels to 15 PSI (1 bar).	<input type="checkbox"/>
3. Mount the steering controls in the normal position.	<input type="checkbox"/>
4. Connect the contact box to the cable for the seat's safety switch.	<input type="checkbox"/>
5. Check that the right amount of oil is in the engine.	<input type="checkbox"/>
6. Adjust the position of the steering controls.	<input type="checkbox"/>
7. Fill with fuel and open the fuel shut off valve.	<input type="checkbox"/>
8. Start the engine.	<input type="checkbox"/>
9. Check that there is drive to both wheels.	<input type="checkbox"/>
10. Check the mower deck adjustment.	<input type="checkbox"/>
11. Check:	<input type="checkbox"/>
The safety switch for the parking brake.	<input type="checkbox"/>
The safety switch for the mower deck.	<input type="checkbox"/>
The safety switch in the seat.	<input type="checkbox"/>
The safety switch in the steering controls.	<input type="checkbox"/>
Parking brake functionality.	<input type="checkbox"/>
Driving forward.	<input type="checkbox"/>
Driving backward.	<input type="checkbox"/>
Engaging the blades.	<input type="checkbox"/>
12. Check the idle speed	<input type="checkbox"/>
13. Check the engine high idle speed	<input type="checkbox"/>
14. Inform the customer about:	<input type="checkbox"/>
The need and advantages of following the service schedule.	Delivery service has been carried out. No remaining notes. Certified:
The need and advantages of leaving the machine for service every 300 hours.	
The effects of service and maintaining a service journal on the machine's resale value.	
Application areas for mulching.	
15. Fill in the sales papers	

---

# SERVICE JOURNAL

---

Action	Date, mtr reading, stamp, sign
<b>After the First 5-8 Hours</b> 1. Change engine oil.	<input data-bbox="1036 373 1065 407" type="checkbox"/>



---

# SERVICE JOURNAL

---

Action	Date, mtr reading, stamp, sign
<p><b>25-Hour Service</b></p> <ol style="list-style-type: none"><li>1. Check the engine air filter.</li><li>2. Sharpen/Replace mower blades if required.</li><li>3. Check the tire pressures.</li><li>4. Check battery with cables.</li><li>5. Lubricate according to lubrication chart.</li><li>6. Check/clean the engine's cooling air intake.</li><li>7. Clean the air cleaner's prefilter (foam).</li></ol>	

---

# SERVICE JOURNAL

---

Action	Date, mtr reading, stamp, sign
<p><b>50-Hour Service</b></p> <ol style="list-style-type: none"><li>1. Perform the 25-hour service.</li><li>2. Clean/replace the air cleaner's filter cartridge (paper filter) (shorter intervals for dusty operating conditions).</li><li>3. Change engine oil.</li><li>4. Lubricate according to lubrication chart.</li><li>5. Check/adjust the parking brake.</li><li>6. Change hydraulic pump oil and filter.</li></ol>	

---

# SERVICE JOURNAL

---

Action	Date, mtr reading, stamp, sign
<p><b>100-Hour Service</b></p> <ol style="list-style-type: none"><li>1. Perform the 25-hour service.</li><li>2. Perform the 50-hour service.</li><li>3. Change the engine oil filter.</li><li>4. Clean/replace the spark plugs.</li><li>5. Replace the fuel filter.</li><li>6. Check V-belts.</li><li>7. Check tighten caster wheel axle bolts (every 200 hours).</li><li>8. Change the air filter's paper cartridge.</li><li>9. Change hydraulic pump oil and filter. (200 hours)</li></ol>	

---

# SERVICE JOURNAL

---

Action	Date, mtr reading, stamp, sign
<p><b>300-Hour Service</b></p> <ol style="list-style-type: none"><li>1. Perform the 25-hour service.</li><li>2. Perform the 50-hour service.</li><li>3. Perform the 100-hour service.</li><li>4. Check/adjust the mower deck.</li><li>5. Clean the combustion chamber and grind the valve seats.</li><li>6. Check the engine valve clearance.</li><li>7. Replace the air cleaner's prefilter (foam).</li></ol>	

---

# SERVICE JOURNAL

---

Action	Date, mtr reading, stamp, sign
<p><b>At Least Once Each Year</b></p> <ol style="list-style-type: none"><li>1. Clean the engine's cooling air intake (25 hours).</li><li>2. Replace the air cleaner's pre-filter (foam) (300 hours).</li><li>3. Replace the air filter's paper cartridge.</li><li>4. Change the engine oil (50 hours).</li><li>5. Replace the engine oil filter (100 hours).</li><li>6. Check/adjust the cutting height.</li><li>7. Check/adjust the parking brake (50 hours).</li><li>8. Clean/change the spark plugs (100 hours).</li><li>9. Change the fuel filter (100 hours).</li><li>10. Check the engine valve clearance.</li></ol>	









## Free Manuals Download Website

<http://myh66.com>

<http://usermanuals.us>

<http://www.somanuals.com>

<http://www.4manuals.cc>

<http://www.manual-lib.com>

<http://www.404manual.com>

<http://www.luxmanual.com>

<http://aubethermostatmanual.com>

Golf course search by state

<http://golfingnear.com>

Email search by domain

<http://emailbydomain.com>

Auto manuals search

<http://auto.somanuals.com>

TV manuals search

<http://tv.somanuals.com>