



INSTALLATION AND OPERATING INSTRUCTIONS

REFRIGERATOR FOR LP-GAS AND ELECTRIC OPERATION

NDR 1292-S

NEW DIMENSIONS

FOR YOUR SAFETY

If you smell gas:

1. Open windows.
2. Don't touch electrical switches.
3. Extinguish any open flame.
4. Immediately call your gas supplier.

FOR YOUR SAFETY

Do not store or use gasoline or other flammable vapors and liquids in the vicinity of this or any other appliance.

WARNING: Improper installation, adjustment, alteration, service or maintenance can cause injury or property damage. Refer to this manual. For assistance or additional information consult a qualified installer, service agency or the gas supplier.

Contents:

	Page
Installation	4
Operating Instructions	8
Maintenance & Service	12



AVIS

Cet appareil doit être réparé seulement par un réparateur autorisé. Modification de l'appareil pourrait être extrêmement dangereuse, et pourrait causer mal ou mort.



USA
 Service Office
 Dometic Corporation
 509 South Poplar Street
 LaGrange, IN 46761
 Phone: 2604634856

corporate office
 2320 Industrial Parkway Elkhart, IN 46515
 For Service Center Assistance
 Call: 800-544-4881

CANADA
 Dometic Distribution Inc
 666 Langs Drive
 Cambridge, Ontario
 N3H2N7 Canada
 Phone: 519-653-4390

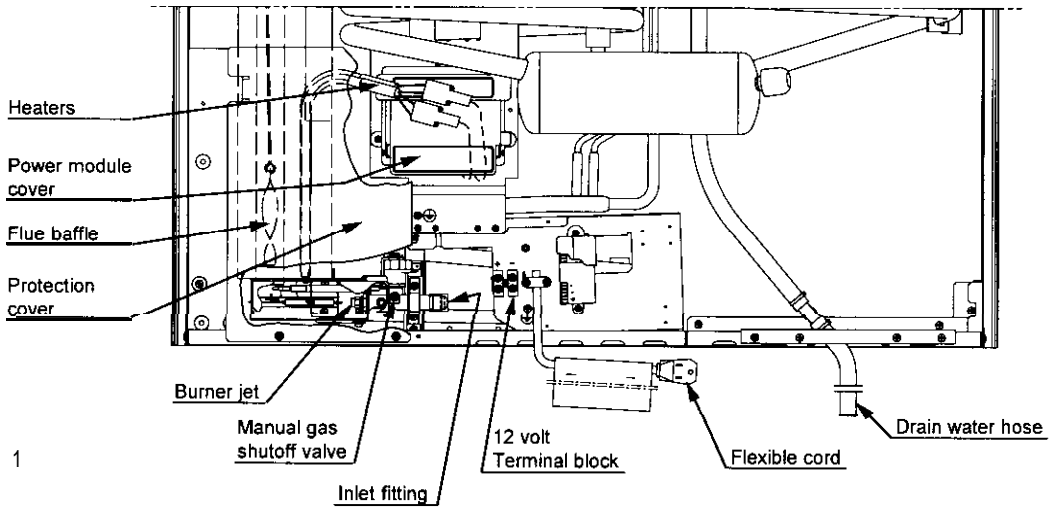
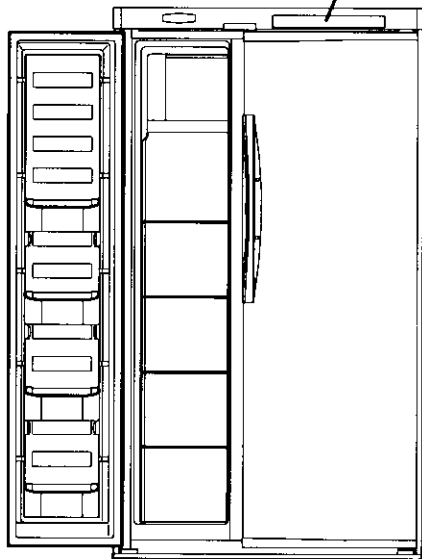
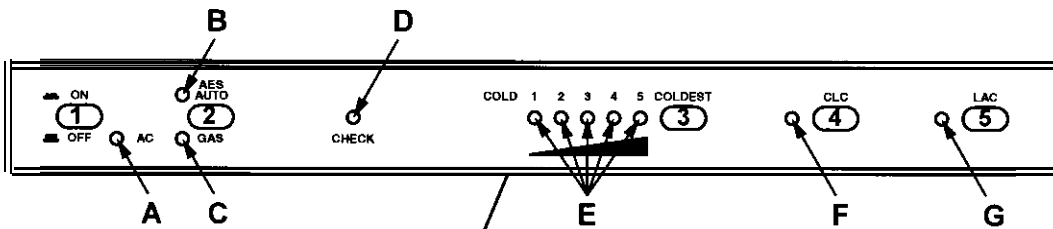

FIG. 1

Refrigerator control panel



LEGEND Z-WAY AES Model

- 1. Main Power Button ON/OFF
- 2. AES/AUTO/GAS Mode Selector Button
- 3. Temperature Selector Button
- 4. Climate Control Button
- 5. Low Ambient Control Button

- A. AC Mode Indicator Lamp
- B. AES/AUTO Mode Indicator Lamp
- C. GAS Mode Indicator Lamp
- D. CHECK Indicator Lamp
- E. Temperature Indicator Lamps
- F. Climate Control Indicator Lamp
- G. Low Ambient Indicator Lamp

FIG. 2

INSTALLATION

GENERAL INSTRUCTION

This appliance is designed for storage of foods and storage of frozen foods and making ice.

The refrigerators outlined herein have been design certified by A.G.A. under the ANSI 221.19 Refrigerator Standard for installation in a mobile home or recreational vehicle and are approved by the Canadian Gas Association.

The certifications are, however contingent on the installation being made in accordance with the following instructions as applicable.

In the U.S.A., the installation must conform with:

1. National Fuel Gas Code ANSI Z223.1.(latest edition)
2. Manufactured Home Construction and Safety Standard Title 24 CFR, Part 3280.
3. Recreational Vehicles ANSI AI 19.2.(latest edition).

The unit must be electrically grounded in accordance with the National Electric Code ANSI/NFPA 70-(latest edition) when installed, if an external alternating current electrical source is utilized.

4. Any applicable local code.

In CANADA, the installation must conform with:

1. Current CAN/CGA 8149 Gas Installation Codes
2. Current CSA Standard 2240.4 GAS-EQUIPPED RECREATIONAL VEHICLES AND MOBILE HOUSING.
3. Where a flexible metal connector is used, it must comply with the provisions of the current Standard CAN1-6.10, METAL CONNECTORS FOR GAS APPLIANCES.

4. Any applicable local code

The unit must be electrically grounded in accordance with the current CANADIAN ELECTRICAL CODE C22 Parts 1 and 2.

VENTILATION

The installation shall be made in such a manner as to separate the combustion system from the living space of the mobile home or recreational vehicle. Openings for air supply or for venting of combustion products shall have a minimum dimension of not less than 1/4 inch.

Proper installation requires one lower fresh air intake and one upper exhaust vent. The ventilation kits shown in this instruction manual have been certified for use with the refrigerator models listed in the table. For "Certified Vent System Kits" see page 14. The ventilation kits must be installed and used without modification. An opening toward the outside at floor level in the refrigerator compartment must be provided for ventilation of heavier-than-air fuel gases. The lower vent of the recommended kits is provided with proper size openings. The flow of combustion and ventilating air must not be obstructed.

The lower side vent is fitted with a panel, which provides an adequate access opening for ready serviceability of the burner and control manifold of the refrigerator. This should be centered on the back of the refrigerator.

GAS CONNECTION

Hook-up to the gas supply line is accomplished at the manual gas valve, which is furnished with a 3/8" SAE (UNF 5/8"-18) male flare connection. All completed connections should be checked for leaks with soapy water.

! WARNING

DO NOT use a flame to check for gas leaks.

The gas supply system must incorporate a pressure regulator to maintain a supply pressure of not more than 11 inches water column.

When testing the gas supply system at test pressures in excess of 1/2 psig, the refrigerator and its individual shutoff valve must be disconnected from the gas supply piping system.

When testing the gas supply system at pressures less than or equal to 1/2 psig, the appliance must be isolated from the gas supply piping system by closing its individual manual shutoff valve.

In case detailed instructions on the installation and connection to the gas supply are required, contact your dealer or distributor.

ELECTRICAL CONNECTION

120 Volts AC Connection

The refrigerator is equipped with a three-prong (grounding) plug for your protection against shock hazards and should be plugged directly into a properly grounded three-prong receptacle. DO NOT cut or remove the grounding prong from this plug. The free length of the cord is 2 feet and therefore recommended that the receptacle be located to the right side of the refrigerator (viewed from the rear) and approximately 10 inches from the floor (see FIG. 3). This allows easy access through the vent door. The cord should be routed to avoid direct contact with the burner cover, flue cover or any other components that could damage the cord insulation,

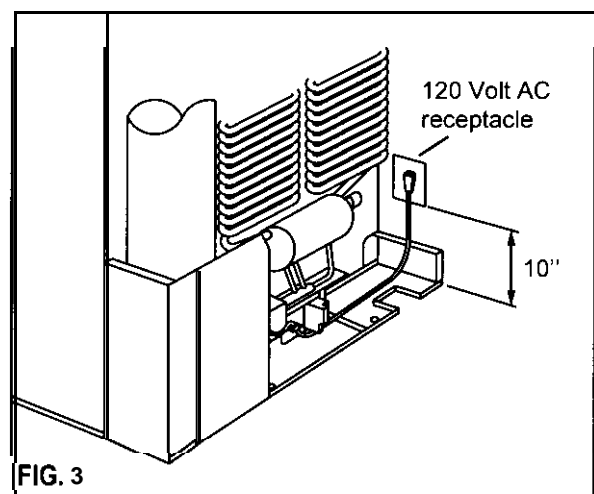

12 Volts DC Connection

The refrigerator model NDR 1292-S require a continuous 12 volt DC supply (even though 2-way models are designed to operate on 120 volts AC and gas, a 12 volt DC control is required to maintain the automatic energy system). The connection is made to the positive (+) and negative (-) terminals of the terminal block on the back of the refrigerator. (See FIG. 1). Correct polarity must be observed when connecting to the DC supply.

Do not use the chassis or vehicle frame as one of the conductors.

Connect **two** wires at the refrigerator and route to the DC supply.

The distance the current must travel from the battery to the refrigerator dictates the AWG wire size to be used. Should the wire be too small for the distance, a voltage drop will result.

Recommended wire sizes **are** shown below.

MAXIMUM TOTAL CONDUCTOR WIRE LENGHT (in feet and meters,

Wire lenght	AWG
17 ft.	14
5 m	
27 ft.	12
8 m	

The wires from the battery to the refrigerator must be of large enough size to handle the load. The connections must be clean, tight and free from corrosion.

INSTALLING REFRIGERATOR IN ENCLOSURE

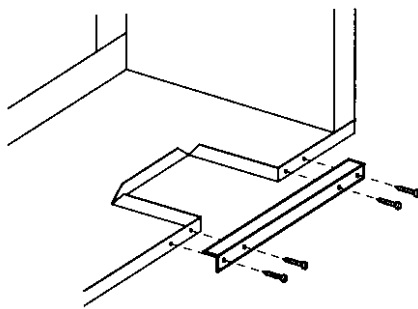

The transport support at the rear of the refrigerator can be removed if necessary for the installation of the refrigerator in the enclosure. (See figure above).

NOTE: **DO NOT install the appliance directly on carpeting. Carpeting must be removed OR protected by a metal or wood panel beneath the appliance, which extends at least full width and depth of the appliance.**

Caution: Use care when installing the refrigerator. This refrigerator is equipped with the latest vacuum insulated panel technology. These insulating panels are located on the Top, Back, Bottom, Sides and Doors of the refrigerator.

If the surface is punctured, loss of insulation will occur, resulting in poor refrigerator performance.

NOTE: A wood strip must be in place across the upper opening of the enclosure. The top frame of the refrigerator will be anchored to the wood strip with screws. see FIG. 10.

The refrigerator must be installed in a substantial enclosure and must be level. When installing the refrigerator in the enclosure, all areas within the recess in which the refrigerator is installed must be sealed.

Make sure that there is a complete **seal** between the front frame of the refrigerator and the top, sides and bottom of the enclosure. A length of sealing strip is applied to the **rear** surface of the front frame for this purpose, see FIG. 4. The sealing should provide a complete isolation of the appliance's combustion system from the vehicle interior.

NOTE: Be careful not to damage the sealing strip when the refrigerator is put in place.

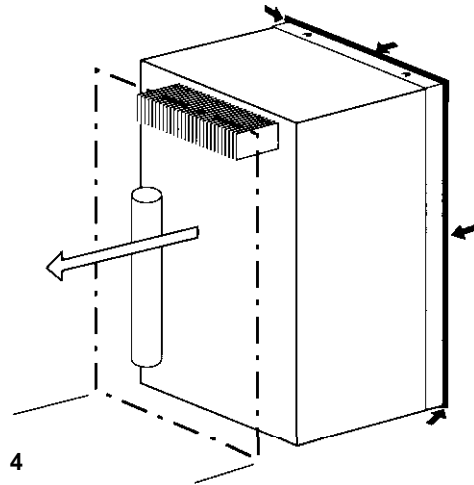

FIG. 4

Securing the Refrigerator

After the refrigerator is put in place, (ensuring a combustion seal at the front frame), the refrigerator is to be secured in the enclosure with six **screws** (not included). The screws have to be installed in the following order:

STEP 1: Two screws installed through the front base, which includes the lower front strip installation.

The refrigerator is provided with a lower front strip (shipped as a loose part). The front strip is to be attached after the refrigerator is set into the cutout opening.

1. Install the lower front strip by sliding it under the bottom hinge plates, as shown in FIG. 5.

FIG. 5

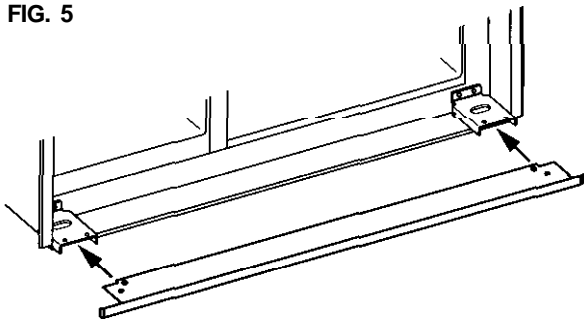
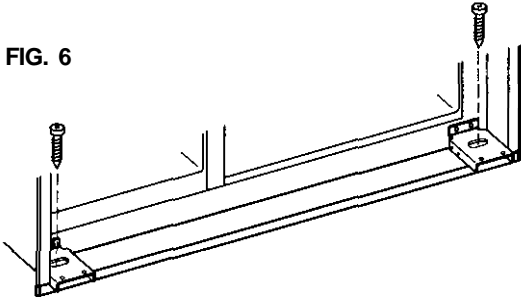

FIG. 6



2. Secure the refrigerator and the lower front strip with two screws: One screw through each hinge. See FIG 6.

Step 2: Two screws installed in the top frame.

The top decoration panel must be removed from the refrigerator before the screws can be installed.

Open the doors and remove the four screws that secure the top decoration panel to the top frame. Two screws are accessible from underneath see FIG. 7, the second two screws that secure the decoration panel to the front frame are located on each side of the lock retainer. Carefully tilt the top decoration panel and lift up to remove from top frame. Be careful not to damage the circuit board and wires.

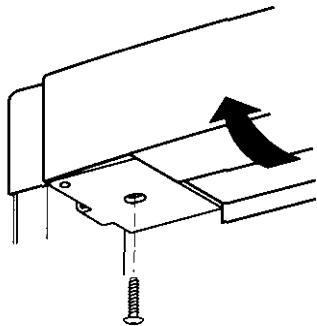

FIG. 7

Install the two screws in the top frame, the holes are accessible from underneath.

Seal the opening for the screws with aluminum tape. Replace the top decoration panel with its four screws. Be careful not to pinch the wires behind the panel.

STEP 3: Two screws installed in the rear base.

See FIG. 8.

Failure to follow the sequence in securing refrigerator in enclosure can cause leakage between the frame and cabinet.

FIG. 6

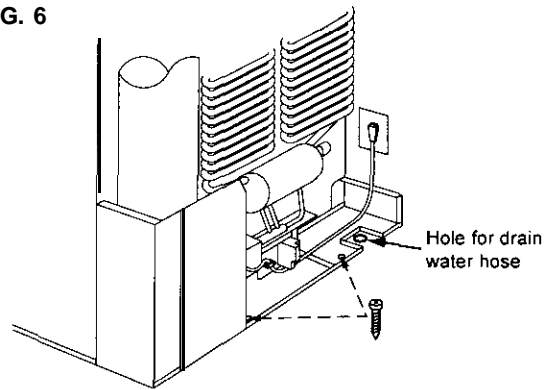

Any space between the counter, storage area or ceiling and top of the refrigerator greater than 1-1/2 inches should be blocked. The heat produced at the rear of the refrigerator will become trapped in this space, making the top of the refrigerator hot and reduce the efficiency of the refrigerator.

Drain water hose

A hole must be drilled through flooring see FIG. 8.

The hole must be drilled in the cut out opening of the base plate at the rear of the refrigerator. The installer MUST make sure that the hose does not kink when run through the floor. Seal around the hose that goes through the drilled hole. If a longer hose than supplied is required to get the water to drain outside of the vehicle, the installer will have to supply the extra length of hose.

TESTING LP GAS SAFETY SHUTOFF

The gas safety shutoff must be tested after the refrigerator is connected to LP gas supply.

To test the gas safety shutoff proceed as follows:

1. Start the refrigerator according to the instructions, and switch to GAS mode. (See start up instructions).
2. Check that the gas flame is lit and the GAS mode indicator lamp (C) is on.
3. Close the manual gas shutoff valve at the back of the refrigerator. (See FIG. 1).
4. Wait for one minute. The CHECK indicator lamp (D) should be on and the GAS mode indicator lamp (C) should be off.
5. Remove protection cover (see FIG. 1) and open the manual gas shutoff valve. Do not change any button positions on the control panel. Apply a non-corrosive commercial bubble solution to the burner jet orifice.
6. No bubbles should appear at the opening of the burner jet orifice. The presence of bubbles indicates a defective gas safety shutoff and service is required.
7. If no bubbles were present at the burner jet orifice, it should be rinsed with fresh water. Be careful not to damage the burner jet orifice. Replace cover and press the main power ON/OFF button (1) OFF and back ON. Normal operation of the burner should return. Allow the burner to operate for a minimum of five minutes.

CERTIFIED INSTALLATION

Certified installations require one roof vent and one lower side vent.

For "Certified Vent System Kits" see page 14.

For further information contact your dealer or distributor.

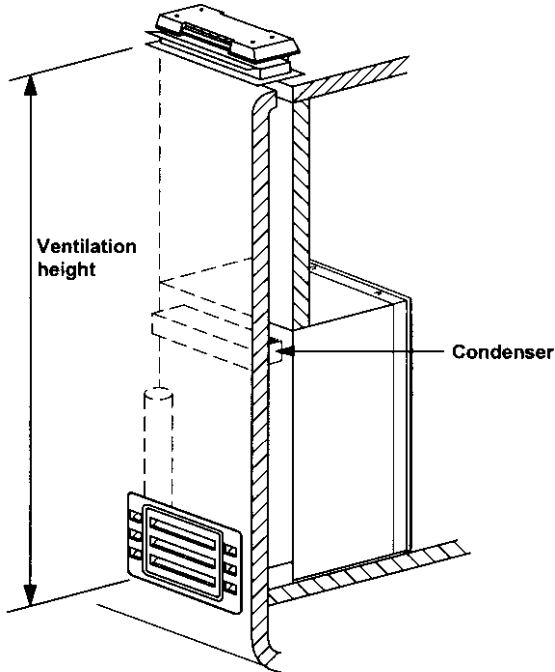

FIG. 9

LOWER VENT CUTOUT

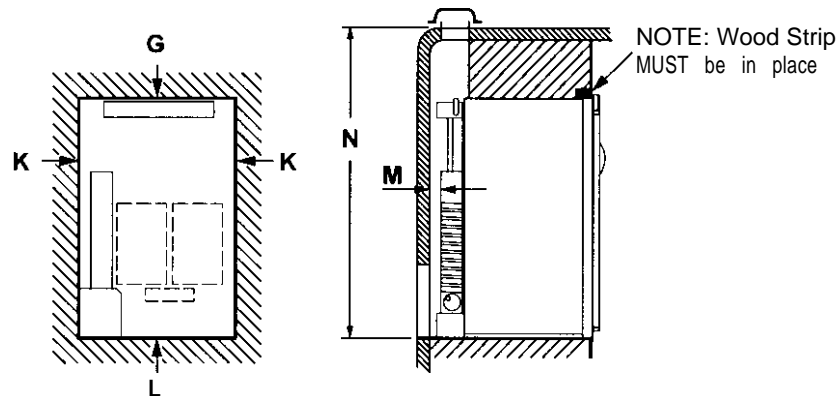
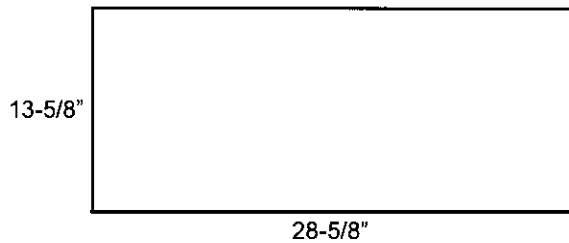

FIG. 10

METHODS OF INSTALLATION

The method of installation is shown in FIG. 9. It is essential that all maximum or minimum dimensions are strictly maintained as the performance of the refrigerator is dependent on adequate flow of air **over** the rear of the refrigerator.

NOTE: The upper vent should be centered over the condenser coil at the back of the refrigerator.

VENTILATION HEIGHTS

Installation with roof vent and lower side vent	Minimum ventilation heights in:	
Refrigerator	Inches	mm
NDR 1292-S	65	1651

CLEARANCES

Minimum clearances in inches to combustible materials are:

G:	Top	0
K:	Side	0
L:	Bottom	0
M:	Rear	0
N:	See NOTE: Clearance "N" below.	

NOTE: Clearance "**M**" is between the **rearmost** part of the refrigerator and the wall behind the refrigerator.

NOTE: Clearance "N" is the distance between the bottom of the lower vent to the roof material. For ventilation height, see table **VENTILATION HEIGHTS**

See Figures 9, and 10.

FIG. 11

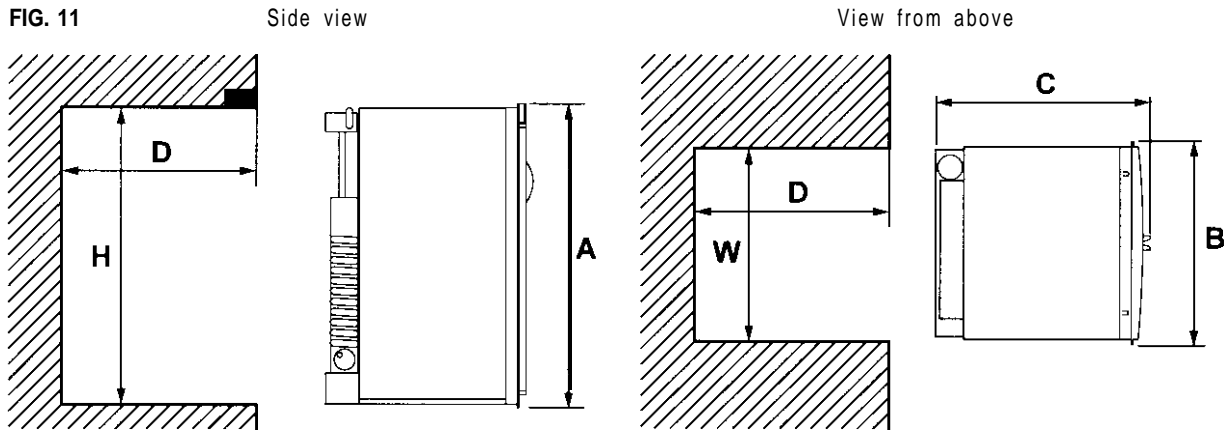

Refrigerator Model	Overall Dimensions			Recess Dimensions			
	Height A	Width B	Depth C	Height H	Width W	Depth D	
NDR 1292-S	inch	59-31/32	33-11/16	27-1/2	59-1/16	32-3/4	24
	mm	1523	855	698	1500	832	610

This method of installation and these clearances will give you adequate space for service and proper installation

OPERATING INSTRUCTIONS

IMPORTANCE OF LEVELING A REFRIGERATOR

In an absorption refrigerator system, ammonia is liquefied in the finned condenser coil at the top rear of the refrigerator. The liquid ammonia then flows into the evaporator (inside the freezer section) and is exposed to a circulating flow of hydrogen gas, which causes the ammonia to evaporate, creating a cold condition in the freezer.

The tubing in the evaporator section is **specifically** sloped to provide a continuous movement of liquid ammonia, flowing downward by gravity through this section. If the refrigerator is operated when it is not level and the vehicle is not moving, liquid ammonia will accumulate in sections of the evaporator tubing. This will slow the circulation of hydrogen and ammonia gas, or in severe cases, completely block it, resulting in a loss of cooling.

Any time the vehicle is parked for several hours with the refrigerator operating, the vehicle should be leveled to prevent this loss of cooling. The vehicle needs to be leveled only so it is comfortable to live in (no noticeable sloping of floor or walls).

When the vehicle is moving, the leveling is not critical, as the rolling and pitching movement of the vehicle will pass to either side of level, keeping the liquid ammonia from accumulating in the evaporator tubing.

OPERATION

Before starting the refrigerator, check that all the manual gas valves are in the ON position. **DO NOT** forget the manual shutoff valve on the rear of the refrigerator see FIG. 1.

This refrigerator is equipped with an Automatic Energy Selector (AES) control system, which can automatically select the most suitable energy source which is available, either 120 Volt AC, or LP gas operation. The system can be set by the user to be fully automatic, or if desired, LP gas only. The refrigerator controls will work down to 9.6 volt DC.

! WARNING

Most LP gas appliances used in recreational vehicles are vented to the outside of the vehicle. When parked close to a gasoline pump, it is possible that the gasoline fumes could enter this type of appliance and ignite from the burner flame, CAUSING A FIRE OR AN EXPLOSION.

FOR YOUR SAFETY, when refueling, shut off all LP gas appliances which are vented to the outside.

DISPLAY PANEL

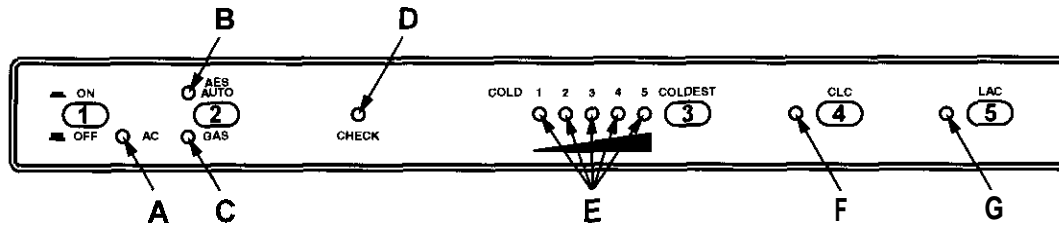

START UP INSTRUCTIONS

- A. A continuous 12 volt DC supply must be available for the electronic control to function.
- B. Press the main power ON/OFF button (1) to the DOWN position.
- C. Press the TEMPERATURE SELECTOR button (3) until the lamp at the desired setting is illuminated.

AES/AUTO MODE

1. Press the AES/AUTO/GAS mode selector button (2) to turn ON the AES/AUTO lamp (B). If 120 volts is available, the AC mode indicator lamp (A) will illuminate indicating AC operation. If 120 volts AC is not available, the GAS indicator lamp (C) will illuminate indicating the control has automatically switched to the GAS mode.
2. If the CHECK indicator lamp (D) illuminates and the GAS mode indicator lamp (C) is off, the controls have failed to ignite the burner in the GAS mode. GAS operation may be reset by pressing the main power ON/OFF button (1) to the OFF then ON position. (See step 2 under GAS MODE).
3. Press the TEMPERATURE SELECTOR button (3) until the lamp at the desired position is illuminated.

GAS MODE

1. Press the AES/AUTO/GAS mode selector button (2) to turn OFF the AES/AUTO lamp (B). The GAS mode indicator lamp (C) will illuminate. Within 45 seconds the burner should be ignited and operating normally.
2. On the initial refrigerator start-up, it may take longer than 45 seconds to allow air to be purged from the gas line. If the gas does not ignite within 45 seconds the CHECK indicator lamp (D) will illuminate and the GAS mode indicator lamp (C) will go off.
To reset when the CHECK indicator lamp (D) is illuminated, press the main power ON/OFF button (1) to the OFF and then ON position.
NOTE: Do not continue to reset GAS operation if the CHECK indicator lamp continues to be illuminated after several tries.
3. Press the TEMPERATURE SELECTOR button (3) until the lamp at the desired position is illuminated.

THERMOSTAT

The thermostat on the refrigerator controls both the gas and electric operation, thereby eliminating the necessity of resetting each time a different energy source is employed.

After the initial start-up, the thermostat should be moved from "COLDEST" to the desired temperature setting, usually at mid setting.

TO SHUT OFF THE REFRIGERATOR

The refrigerator may be shut off while in any mode of operation by pressing the main power ON/OFF button to the UP (OFF) position. This shuts off all DC power to the refrigerator, including the interior light.

DISPLAY PANEL

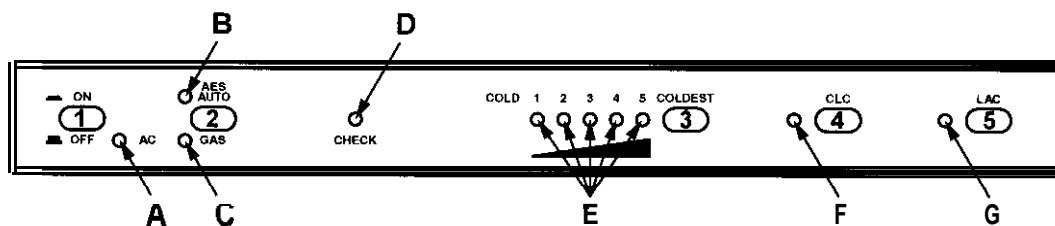

DESCRIPTION OF OPERATING MODES

AES/AUTO MODE

When operating in the AES/AUTO mode, the AES/AUTO mode indicator lamp (B) will illuminate. The control system will automatically select between AC and GAS operation with AC having priority over GAS. Either the AC indicator lamp (A) or the GAS indicator lamp (C) will illuminate depending on the energy source selected by the control system. If the control system is operating with AC energy and it then becomes unavailable, the system will automatically switch to GAS. As soon as AC becomes available again the control will switch back to AC regardless of the status of GAS operation.

GAS MODE

When operating in the GAS mode the AES/AUTO mode indicator lamp (B) will be off and the GAS mode indicator lamp (C) will be illuminated. This mode provides LP gas operation only. The control system will activate the ignition system and will attempt to light the burner for a period of approximately 45 seconds. If unsuccessful, the CHECK indicator lamp (D) will illuminate and the GAS mode indicator lamp (C) will turn off.

To restart GAS operation, press the main power ON/OFF button (1) to the OFF and then ON position. The control system will attempt a new 45 seconds ignition sequence.

If the refrigerator has not been used for a long time or the LP tanks have just been refilled, air may be trapped in the supply lines. To purge the air from the lines may require resetting the main power ON/OFF button (1) three or four times. If repeated attempts fail to start the LP gas operation, check to make sure that the LP gas supply tanks are not empty and all manual shutoff valves in the lines are open. If the problem is still not corrected, contact a service center for assistance.

If the control is switched to AC operation while the CHECK indicator lamp is on, it will function properly, but the CHECK indicator lamp will not go off until the main power ON/OFF button is pressed to the OFF then ON position.

LIMP MODE OF OPERATION

This control system contains a feature where it will continue to operate the cooling system in the event of a failure of a major operating component. Two different modes of operation can occur in this category

If for some reason the display module becomes non functional, the control system will revert to full automatic operation selecting the best energy source available with AC, GAS priority. The temperature of the refrigerator will be maintained at the MID position within normal temperature tolerances. The power module will continually attempt to reestablish operation of the display module.

The second limp mode of operation will execute when a failure of the temperature sensing device or associated electronic circuitry occurs. If this should occur, the control system will operate on the energy source selected via the control panel. The cooling unit will run continuously on the selected energy source. The refrigerator will continue to operate in this mode indefinitely or until a new sensor is installed and the system is reset.

HOW TO USE THE REFRIGERATOR

FOOD STORAGE COMPARTMENT

The food storage compartment is completely closed and unventilated, which is necessary to maintain the required low temperature for food storage. Consequently, foods having a strong odor or those that absorb odors easily should be covered. Vegetables, salads etc. should be covered to retain their crispness. The coldest positions in the refrigerator are under the cooling fins and at the bottom of the refrigerator. The warmer areas are on the upper door shelves. This should be considered when placing different types of food in the refrigerator. When the refrigerator is heavily loaded, it will take a longer time to lower the temperature; therefore, to get maximum efficiency the refrigerator and food items should be pre-cooled prior to loading. The shelves should not be covered with paper or plastic, and the food items should be arranged so air can circulate freely. Two door shelves are equipped with fingers. The fingers are designed to prevent large containers (1/2-gallon milk or juice) from **shifting** or spilling while traveling.

FROZEN FOOD STORAGE COMPARTMENT

Quick frozen soft fruits and ice cream should be placed in the coldest part of the compartment, which is on the top freezer shelf. Frozen vegetables, may be stored in any part of the compartment.

This compartment is not designed for deep or quick-freezing of food. Meat or fish, whether raw or prepared, can be stored in the frozen food storage compartment provided they are pre-cooled first in the refrigerator. They can be stored about three times longer in the frozen food compartment as compared to the fresh food compartment. To prevent food from drying out, keep it in covered dishes, containers, plastic bags or wrapped in aluminum foil.

Total Refrigerated Volume 12 cu.ft.

ICE MAKING

Ice cubes can be made in the ice trays placed in the freezer compartment. The trays should be filled with water to within 1/4" (5 mm) from the top. For faster ice making, the trays should be placed in direct contact with the freezer shelves.

To release the ice cubes seize the tray with both hands and **twist** the tray. Cubes not required should be replaced in the tray. Refill the tray with water and replace the tray on the freezer shelf.

Ice will be made more rapidly if the thermostat is set at its highest position.

It is a good idea to do this a few hours before the anticipated need for ice, but be sure to move the thermostat back to normal setting, usually about mid setting when the ice is formed. Food in the fresh food compartment may be frozen if the setting is left on "COLDEST" position.

DEFROSTING

Shut off the refrigerator by pressing the main power ON/OFF button to the UP (OFF) position.

Empty the refrigerator, leaving the drip tray under the finned evaporator, and the cabinet and freezer doors open. Filling the ice trays with hot water and placing them on the freezer shelves can reduce defrosting time. When all the frost has melted, dry the interior of the refrigerator and freezer with a clean cloth. Replace all food and set the thermostat to the COLDEST temperature setting for a few hours. Then reset the thermostat to the desired setting, usually at mid setting.

! CAUTION

DO NOT use a hot air blower. Permanent damage could result from warping the metal or plastic parts. DO NOT use a knife or an ice pick, or other sharp tools to remove frost from the freezer shelves. They can create a leak in the ammonia system.

CLEANING

Cleaning the refrigerator is usually done after it is defrosted or put into storage. To clean the interior liner of the refrigerator, use lukewarm weak soda solution. Use only warm water to clean the finned evaporator, ice trays and shelves. NEVER use strong chemicals or abrasives to clean these parts, as the protective surfaces will be damaged. It is important to always keep the refrigerator clean.

SHUT OFF - STORAGE PROCEDURE

Shut off the refrigerator by pressing the main power ON/OFF button to the UP (OFF) position.

If the refrigerator will not be in operation for a period of weeks, it should be emptied, defrosted, cleaned and the doors left ajar. The ice trays should also be dried and kept outside the cabinet.

! WARNING

DO NOT store explosive substances in the refrigerator, such as cigarette lighter gas, petrol, ether or the like.

NOTE: Sodium chromate is used for corrosion protection (less than 2-weight % of the coolant).

CLIMATE CONTROL

During the summer months of high temperatures and humidity the metal frame between the freezer and fresh food compartments may have water droplets forming. The number of water droplets will increase if the vehicle isn't air conditioned during these months.

This refrigerator comes standard with a 12 volt (DC) climate control that will evaporate the water droplets when they form.

To turn on the climate control, press the CLG button (4) on the display panel, the indicator lamp (F) will illuminate. (See FIG. 2 or display panel, section OPERATING INSTRUCTIONS).

The climate control can be left on continuously or only used when temperatures require it.

NOTE: The climate control will draw 12 volt DC power continuously when in the ON position. It should be turned OFF when a charging source is not available.

LOW AMBIENT CONTROL

All RV absorption refrigerators, while similar, operate a little differently than your home refrigerator. Dometic designers and engineers have equipped your refrigerator with an exclusive feature that allows for trouble-free operation in low ambient temperature (like below 50°F) for extended periods of time. Simply press the LAC-button (5) on the display panel, the indicator lamp (G) will illuminate (see FIG. 2 or display panel, section OPERATING INSTRUCTIONS). Once the outdoor temperature is above 50°F, the low ambient switch should be turned off.

ELECTRIC EQUIPMENT

CARTRIDGE HEATER

The heat necessary for the operation of an absorption cooling unit is supplied by an electric heater mounted in a pocket of the boiler system.

This model is equipped with **two** electrical heaters for 120 volt AC.

To replace the heater proceed as follows:

1. Disconnect the wall plug, and the 12 volt wires.
2. Remove the protection cover see FIG. 1
3. Remove the power module cover see FIG. 1
4. Disconnect the heater leads.
5. With a pair of pliers unfold the lug holding the lid of the boiler casing and open the lid.
6. Remove some insulation wool so that the heater is accessible.
7. Turn and lift the heater out of its pocket.
8. Fit the new heater into the pocket.
9. Connect the leads and put on the power module cover.
10. Reset the insulation and close the lid of the boiler.
11. Replace the protection cover.

FUSES

This model is equipped with 2 fuses, one for the refrigerator control system and one for AC cartridge heater. (See table below).

To replace fuses proceed as follows.

1. Disconnect the wall plug, and the 12 volt wires.
2. Remove the power module cover. See FIG. 1.
3. Snap the fuse out of the fuse holder.
4. Fit a new fuse in to the fuse holder.
5. Replace the power module cover.

Control system	3 Amp
AC heater	5 Amp

MAINTENANCE & SERVICE

The user should be aware of service that must be done on a regular schedule to keep the refrigerator operating properly. The service should only be performed by a qualified technician who is familiar with LP gas systems and refrigerators.

1. REFRIGERATOR REMOVAL

Before working on the refrigerator, make sure the AC voltage and DC voltage leads are disconnected. Shut off the gas supply. Disconnect the gas supply line at the rear of the refrigerator see FIG. 1. Always use a back up wrench when loosening and tightening this connection. Cap the gas supply line loosen the screws anchoring the refrigerator to the enclosure and slide the refrigerator out of the compartment.

When replacing the refrigerator make sure that the sealing strips are properly positioned.

Replacement is the reverse of removal. Check all connections for gas leaks.

Refer to section **INSTALLATION**, page 4 to 8.

2. PERIODIC MAINTENANCE

To keep your **Dometic** refrigerator operating efficiently and safely, periodic inspection and cleaning of **several** components once or twice a year is recommended.

- A It is important to keep the area at the back of the refrigerator clean. Check the lower vent, upper vent and area between these openings for any obstructions such as bird/insect nests, spider webs, etc. Clean the coils on the back of the refrigerator. Use a soft bristled brush to dust off the coils.

It is important to keep the refrigerator area free from combustible material, gasoline and other flammable vapors or liquids.

NOTE: The following maintenance is required once or twice a year, but should only be done by a qualified serviceman who is familiar with LP gas systems and refrigerators.

- B. Check all connections in the LP gas system (at the back of the refrigerator) for gas leaks. The LP gas supply must be turned on. Apply a non-corrosive bubble solution to all LP gas connections. The appearance of bubbles indicates a leak and should be repaired immediately by a **QUALIFIED SERVICE-MAN WHO IS FAMILIAR WITH GAS SYSTEM AND REFRIGERATORS.**

! WARNING

DO NOT use a flame to check for gas leaks.

- C. Check the AES control system by **connecting/disconnecting** 120 volt AC power. start/stop the engine, etc. Compare the operation with the operation described in description of operating modes. Page 10.
- D. The LP gas pressure should be checked and the main regulator re-adjusted if pressure is incorrect.

GAS EQUIPMENT ASSEMBLY

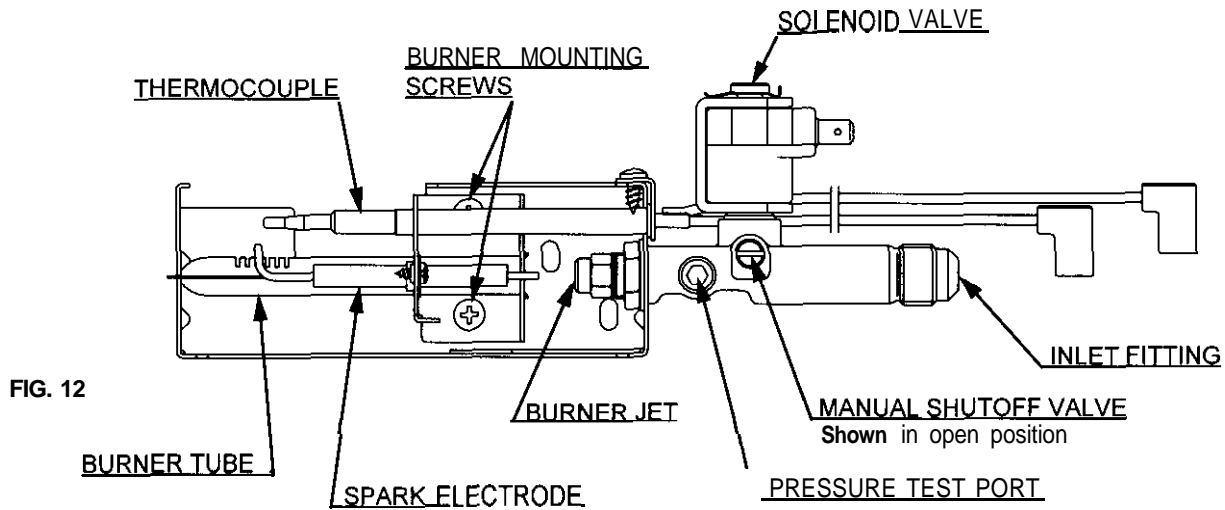

FIG. 12

The correct operating pressure is 11 inches of water column. The correct place to take the LP gas pressure is at the test port just ahead of the burner jet. (See FIG. 12).

- E. Inspect the flue baffle. It should be reasonably clean and free of soot. Heavy soot formation indicates improper functioning of the burner. The flue and burner both require cleaning in the following manner:
1. Unplug the refrigerator power cord from the 120 volt AC outlet. (See FIG. 3).
 2. Disconnect or shut off the 12 volt power to the refrigerator.
 3. Turn manual shutoff valve to OFF. (See FIG. 1).
 4. **Remove cover** from the burner housing. (See FIG. 1).
 5. Disconnect the wire from the high voltage electrode.
 6. Remove the burner mounting screws and remove the burner assembly. (See FIG. 12).
 7. Remove the wire and the flue baffle from the top of flue tube. Clean the flue from the top using a flue brush. Blowing compressed air into the flue will not properly clean soot and scale out of the flue tube. Replace the flue baffle.
 8. Clean burner tube with a brush. Blow out burner with compressed air.
 9. Before removing burner jet, clean burner area of soot and scale that fell out of flue tube. Remove the burner jet. Soak the jet in wood alcohol and blow it out with compressed air. Re-install and tighten burner jet. NOTE: The color of the flame shall be clear blue over the slots of the burner. (See FIG. 13).

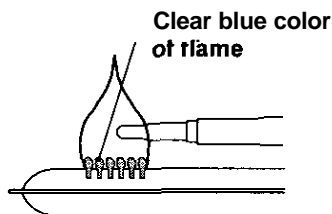
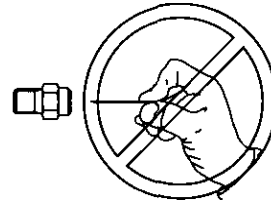

FIG. 13

! WARNING

DO NOT use a wire or pin when cleaning the burner jet as damage can occur to the precision opening. This can cause damage to the refrigerator or create a fire hazard.



10. Reinstall burner, being careful that the end of the burner fits into the slot on the burner bracket. Check to make sure slots are centered under the flue tube and the thermocouple is positioned properly (tip of thermocouple extends over **two** slots of burner).
11. Be sure to reconnect the wire to high voltage electrode. Check the electrode for proper location and gap. (See FIG. 14).

FIG. 14

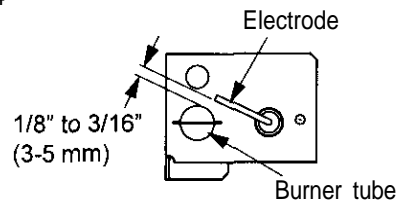

12. Turn on manual gas shutoff valve and check all fittings for leaks.
13. Connect 120 volt power cord to the outlet and reconnect or turn on the 12 volt DC power.
14. Check LP gas safety shutoff. See page 6.

TROUBLESHOOTING

The Refrigerator Does Not Cool Properly

- A. Burner jet clogged.
Clean. (See section Maintenance & Service, Item 2. Periodic Maintenance, Paragraph E. Item 1-14.)
- B. Check level of refrigerator.
- C. Venting problem.
Restriction in air flow across cooling unit.
- D. Heavy frost buildup on evaporator fins.
Defrost.
- E. Flue baffle not inserted properly in flue tube.
- F. Improperly set thermostat.
(See section Operating Instructions. part Start Up Instructions.)
- G. Burner dirty.
Clean. (See section Maintenance & Service, Item 2. Periodic Maintenance, Paragraph E. Item 1-14.)
- H. LP gas pressure low at burner.
Set main regulator so pressure does not drop below 11 inches water column at pressure tap.
- I. Burner not located properly under flue tube.
Relocate.
- J. Burner damaged.
Replace.
- K. Odors from fumes.
 - 1. Dislocated burner.
 - 2. Damaged burner.
 - 3. Dirty flue tube.
- L. FUSES
 - 1. Refrigerator AC Supply.
 - 2. Control system. See page 12, part Fuses.

NOTE: AVOID SPRAYING WATER THROUGH THE REFRIGERATOR VENTS WHILE WASHING YOUR RV.

All the above instructions are to be followed closely. The refrigerator is **quality-guaranteed**. However, we are not responsible for any failures caused by improper adjustments and unfavorable installation conditions. Contact Service point or distributor service dept. for assistance.

Replacement Parts Suppliers: See page 1.

SPARE PARTS

The following list is a list of commonly used parts, which should be available, if required, from your **Dometic Service Center**.

Part No.	Description
17 37 69-01/9	Heater, 210W, 120V
95 50 01-67/2	Burner pipe, cpl.
200 74 19-33/2	Jet, No. 76
293 11 32-01/9	Spark ignition device
293 27 81-02/0	Electrode, with conductor
293 18 26-02/4	Thermocouple
293 21 06-01/2	Lamp cover
293 25 83-03/8	Doorshelf, 6 pieces
293 25 77-02/2	Doorshelf, freezer
200 27 26-12/9	Box vegetable-, (crisper)
200 27 26-1 3/7	Box vegetable-, (crisper)
200 27 26-14/5	Box vegetable-, (meat locker)
293 26 58-01/2	Bottle holder, 2 pieces
293 26 67-05/4	Baffle

Contact an authorized service center for parts and repairs as needed.

CERTIFIED VENT SYSTEM KITS

REFRIGERATOR MODEL	KIT NO.	COMPONENTS	PART NO.
NDR 1292-S	5A	Roof Base	3103633.XXX*
		Roof Cover	3103634.XXX*
		Lower Side Vent	3109349.XXX*
		Power Vent Asm.	3108705.744**

* Fill in "XXX" with color code numbers. For color codes, contact your supplier.

** Alternate instructions forwarded with the Ventilator Kit.

For further information contact your dealer or distributor.

Positioning of shelves

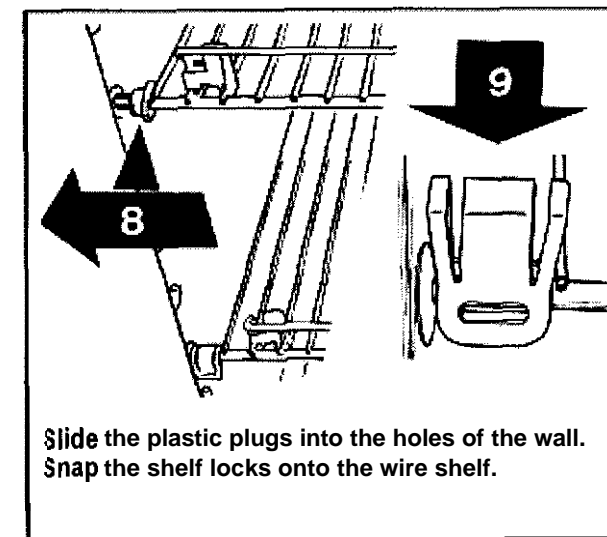
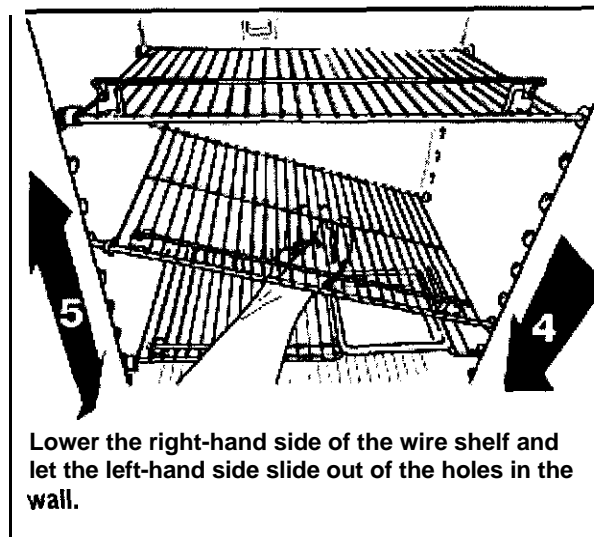
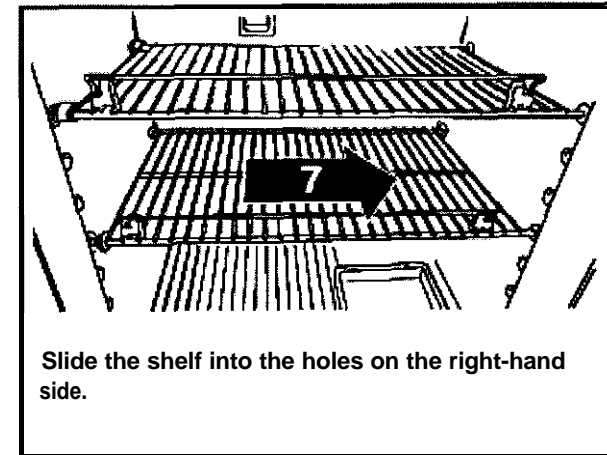
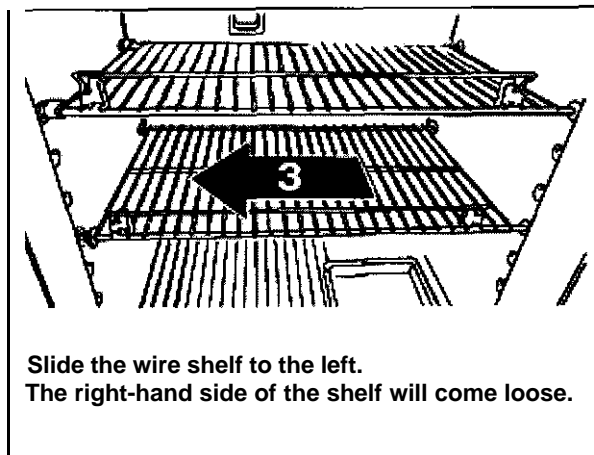
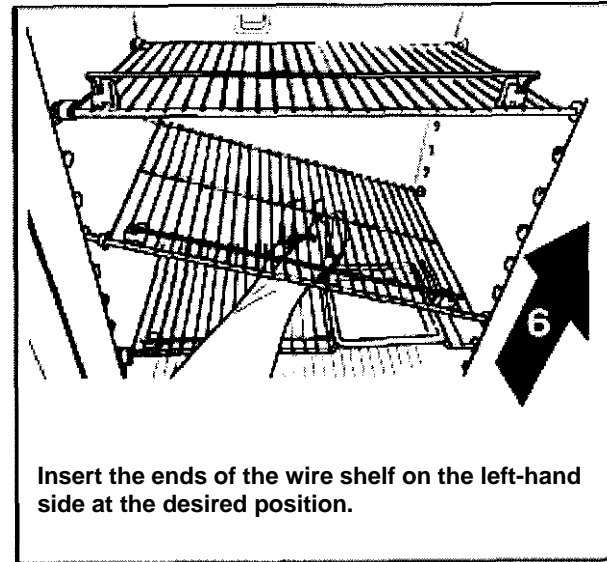
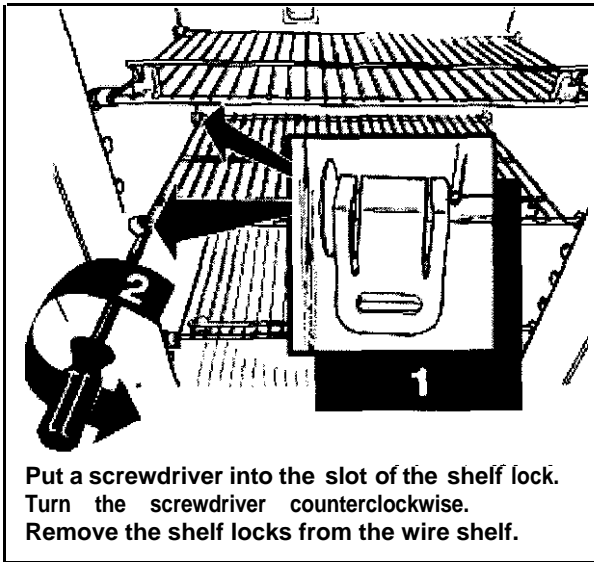

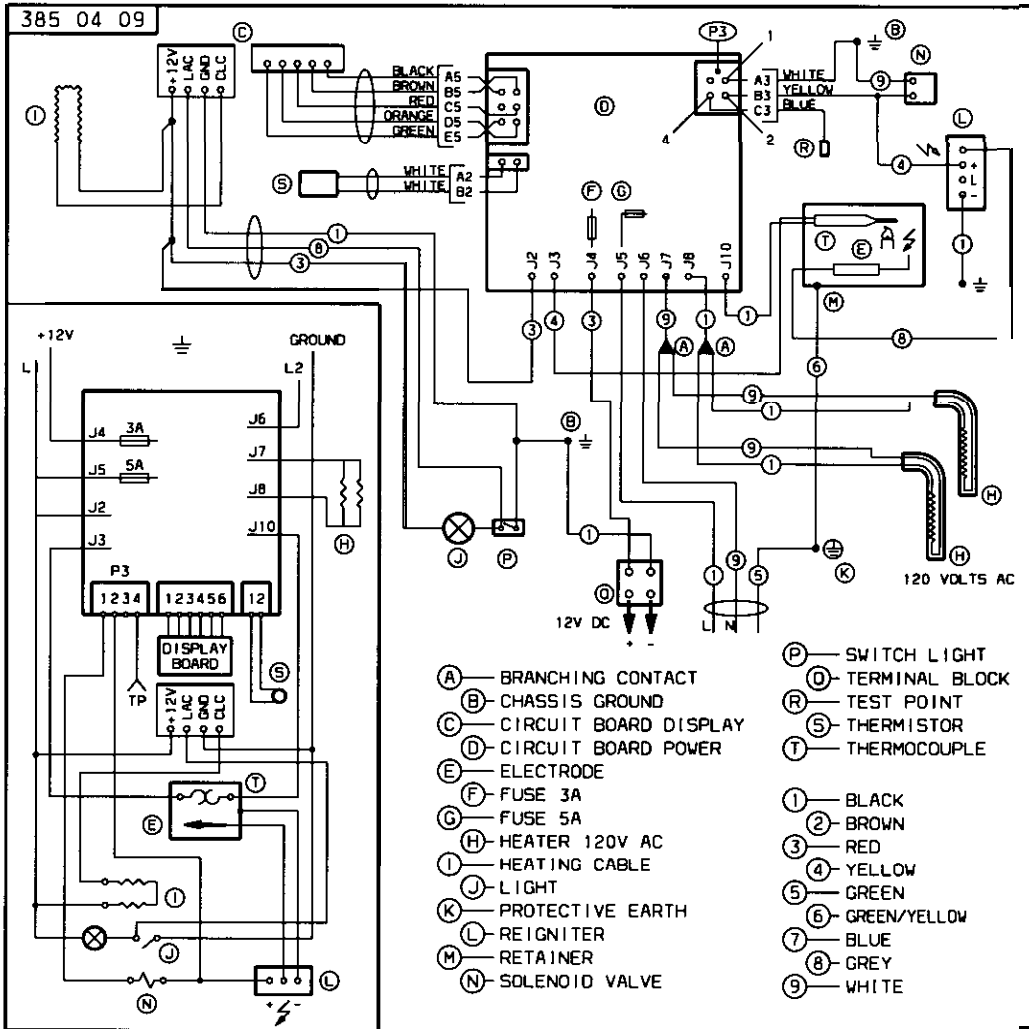

Free Manuals Download Website

<http://myh66.com>

<http://usermanuals.us>

<http://www.somanuals.com>

<http://www.4manuals.cc>

<http://www.manual-lib.com>

<http://www.404manual.com>

<http://www.luxmanual.com>

<http://aubethermostatmanual.com>

Golf course search by state

<http://golfingnear.com>

Email search by domain

<http://emailbydomain.com>

Auto manuals search

<http://auto.somanuals.com>

TV manuals search

<http://tv.somanuals.com>