

INSTALLATION AND MAINTENANCE INSTRUCTIONS (2,4)SH13 Series Self-Contained Heat Pump

WARNING

Improper installation, adjustment, alteration, service, or maintenance can cause injury or property damage. Refer to this manual. For assistance or additional information, consult a qualified installer or service agency.

WARNING

Installation and servicing of air conditioning equipment can be hazardous due to internal refrigerant pressure and live electrical components. Only trained and qualified service personnel should install or service this equipment. Installation and service performed by unqualified persons can result in property damage, personal injury, or death.

WARNING

If this unit is to be installed in a mobile or manufactured home application, the ductwork must be sized to achieve static pressures within the manufacturer's guidelines. All other installation guidelines must also be followed. Failure to do so may result in equipment damage, personal injury, and improper performance of the unit.



WARNING

Sharp metal edges can cause injury. When installing the unit, use care to avoid sharp edges.

TABLE OF CONTENTS

INSTALLATION	2
OPERATION	7
MAINTENANCE.....	10
WIRING DIAGRAM	11
WARRANTY	12

Manufactured By
A.A.C.
A Lennox International Inc. Company
421 Monroe Street
Bellevue, OH 44811

CAUTION

The installation of this appliance must conform to the requirements of the National Fire Protection Association; the National Electrical Code, ANSI/NFPA No. 70 (latest edition) in the United States; the Canadian Electrical Code Part 1, CSA 22.1 (latest edition) in Canada; and any state or provincial laws or local ordinances. Local authorities having jurisdiction should be consulted before installation is made. Such applicable regulations or requirements take precedence over the general instructions in this manual.

INSTALLATION

These instructions explain the recommended method of installation of the SH heat pump unit and associated electrical wiring.

This unit is designed and approved for use as a self-contained air-to-air outdoor heat pump system.

The units are factory equipped with a transformer and blower control for applications without auxiliary heat. Electric heat accessory kits (PHK) can be ordered for field installation of additional heat where required.

These instructions, and any instructions packaged with mating components and/or accessories, should be carefully read prior to beginning installation. Note particularly any **CAUTIONS** or **WARNINGS** in these instructions and all labels on the units.

These instructions are intended as a general guide only, for use by qualified personnel and do not supersede any national or local codes in any way. Compliance with all local, state, provincial, or national codes pertaining to this type of equipment should be determined prior to installation.

IMPORTANT: This product has been designed and manufactured to meet ENERGY STAR criteria for energy efficiency. However, proper refrigerant charge and proper air flow are critical to achieve rated capacity and efficiency. Installation of this product should follow the manufacturer's refrigerant charging and air flow instructions. **Failure to confirm proper charge and airflow may reduce energy efficiency and shorten equipment life.**

Inspection of Shipment

Upon receipt of equipment, carefully inspect it for possible shipping damage. If damage is found, it should be noted on the carrier's freight bill. Take special care to examine the unit inside the carton if the carton is damaged. File a claim with the transportation company.

If any damages are discovered and reported to the carrier **DO NOT INSTALL THE UNIT, as claim may be denied.**

Check the unit rating plate to confirm specifications are as ordered.

Limitations

The unit should be installed in accordance with all national and local safety codes.

Limitations of the unit and appropriate accessories must also be observed.

The unit must not be installed with any ductwork in the outdoor air stream. The outdoor fan is not designed to operate against any additional static pressure.

Location

The unit is designed to be located outdoors with sufficient clearance for free entrance to the air inlet and discharge air openings. The location must also allow for adequate service access.

The unit must be installed on a solid foundation that will not settle or shift. Adequate structural support must be provided. Maintain minimum clearances as shown in Figure 1 and Table 1 and install the unit in level position. Isolate the base from the building structure to avoid possible transmission of sound or vibration into the conditioned space.

The unit foundation should be raised to a minimum of 3" above finish grade. In areas which have prolonged periods of temperature below freezing and snowfall, the unit should be elevated above the average snow line. Extra precaution should be taken to allow free drainage of condensate from defrost cycles to prevent ice accumulation. The unit should not be located near walkways to prevent possible icing of surface from defrost condensate.

Avoid placing the unit near quiet areas such as sleeping quarters or study rooms. Normal operating sound levels may be objectionable if the unit is placed near certain rooms.

Do not permit overhanging structures or shrubs to obstruct condenser air discharge inlet or outlet.

For improved start-up performance, the indoor coil should be washed with suitable detergent to remove any residue from manufacturing processes.

Exercise care when moving the unit. Do not remove any packaging until the unit is near the place of installation. An accessory lift kit can be purchased to aid in rigging (see Figure 1). Spreaders whose length exceed the largest dimension across the unit **must be used across the top of the unit.** Recommended spreader length: 3 ton and smaller package units – 44", 3.5 ton and larger units – 54".

Units may also be moved or lifted with a forklift while still in the factory-supplied packaging. **The lengths of the forks of the forklift must be a minimum of 42".**

CAUTION

Before lifting a unit, make sure that the weight is distributed equally on the cables so that it will lift evenly.

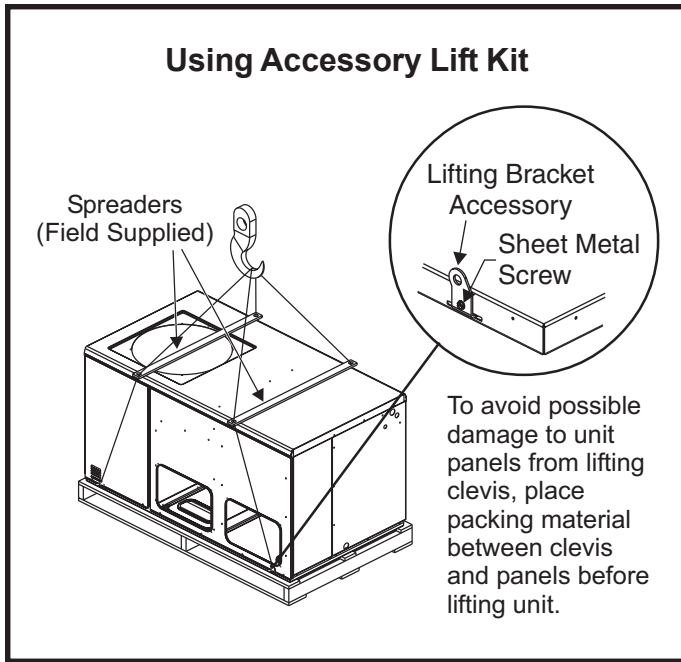

Roof Curb Installation

If a roof curb is used, follow the manufacturer's Installation Instructions and be sure that all required clearances are observed (see following **Clearances** section).

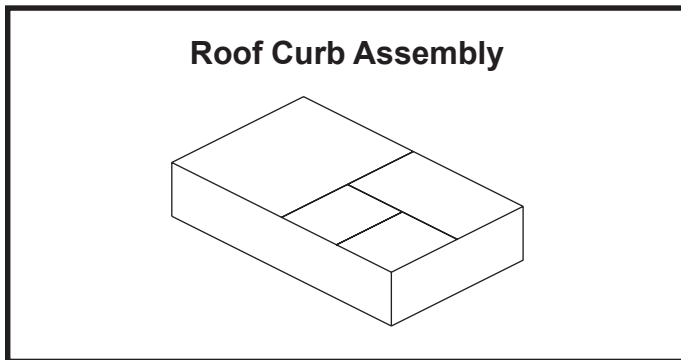

Clearances

All units require certain clearances for proper operation and service. Refer to Table 1 for the minimum clearances to combustibles as well as minimum clearances necessary for servicing and proper unit operation.

In the U.S., units may be installed on combustible floors made from wood or class A, B, or C roof covering material. In Canada, units may be installed on combustible floors.

Service Access

Access to all serviceable components is provided by four removable panels: filter compartment, blower compartment, heater compartment, and top panel.

Minimum Clearance Requirements

	To Combustible Material	For Service	For Proper Operation
Front	0"	48"	3"
Rear	0"	24"	3"
Condenser End	0"	24"	3"
Blower End	0"	30"	0"
Top	0"	36"	36"

Table 1

Condensate Drain

The SH package unit is equipped with a 3/4" FPT coupling for condensate line connection. Plumbing must conform to local codes. Use a sealing compound on male pipe threads.

The condensate drain line must be properly trapped and routed to a suitable drain. See Figure 3 for proper drain arrangement. The drain line must pitch to an open drain or pump to prevent clogging of the line. Seal around the drain connection with suitable material to prevent air leakage into the return air system.

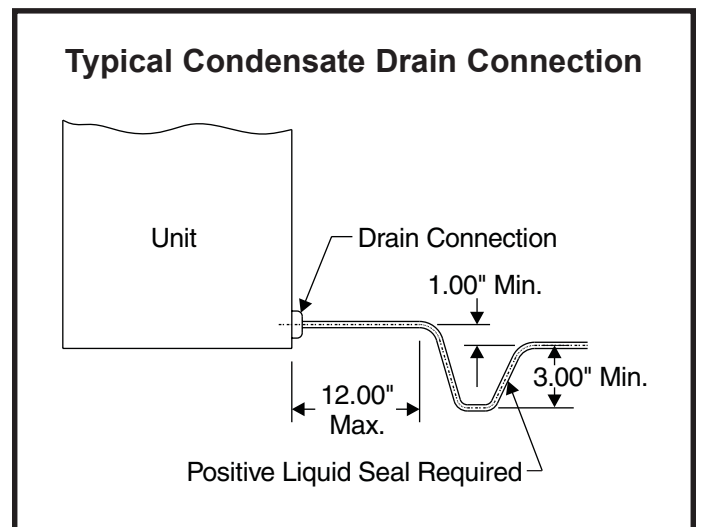

Ductwork

Ductwork should be designed and sized according to the methods in Manual Q of the Air Conditioning Contractors of America (ACCA).

A closed return duct system shall be used. This shall not preclude use of economizers or outdoor fresh air intake. It is recommended that supply and return duct connections at the unit be made with flexible joints.

The supply and return air duct systems should be designed for the CFM and static requirements of the job. **They should not be sized by matching the dimensions of the duct connections on the unit.**

Outdoor ductwork must be insulated and waterproofed.

Equipment is shipped for side ductwork connection. The unit can be converted to bottom ductwork connection by removing the duct covers located over the bottom duct openings and placing these covers over the side duct openings (see Figure 4).

To remove the bottom duct cover over supply opening:

1. Remove screw on cover nearest side opening.
2. Lift end of cover slightly and push to slide back screw/pin free from duct flange.
3. Slide duct cover out the side duct opening.

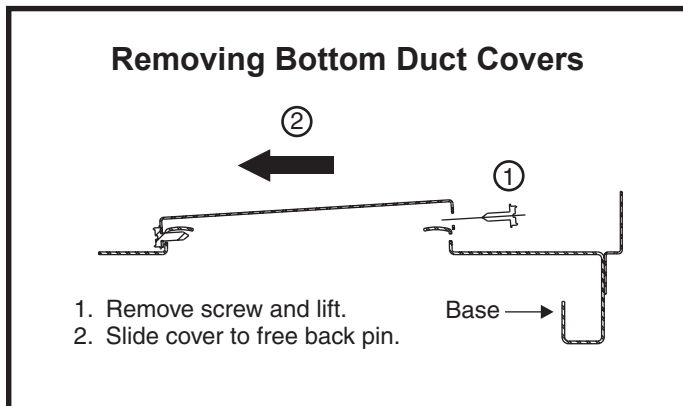

Figure 4

CAUTION

When fastening ductwork to side duct flanges on unit, insert screws through duct flanges only; do not insert screws through casing. If using bottom duct work, do not use screws to secure ductwork to bottom duct opening under drain pan side. Using screws to secure bottom duct may damage drain pan.

Filters

Air filters are to be used with this heating/cooling unit. Filters are not factory supplied in the unit. However, a filter frame accessory is available from the manufacturer that allows filters to be installed within the unit. If the filter frame accessory is not used, a filter must be installed in the duct work by the installer. Filters must always be installed ahead of the evaporator coil and must be kept clean or replaced. Dirty filters will reduce the airflow of the unit. Filters should be sized in accordance with Table 2.

Nominal Cooling	Filter Area (sq. ft.)
24,000	2.67
30,000	3.33
36,000	4.00
42,000	4.67
48,000	5.33
60,000	6.67

Table 2

Electrical Wiring

WARNING

Line voltage is present at all components when unit is not in operation on units with single pole contactors. Disconnect all remote electric power supplies before opening access panel. Unit may have multiple power supplies. Failure to disconnect all power supplies could result in personal injury or death.

All wiring should be done in accordance with the National Electrical Code, ANSI/NFPA No. 70 (latest edition); Canadian Electrical Code Part 1, CSA C22.1 (latest edition); or local codes where they prevail. Use wiring with a temperature limitation of 75°C minimum. Run the 208 or 230 volt, 60 hertz electric power supply through a fused disconnect switch to the connection box of the unit and connect as shown in the wiring diagram located on the inside of the control access panel.

CAUTION

When connecting electrical power and control wiring to the unit, waterproof type connectors must be used so that water or moisture cannot be drawn into the unit during normal operation.

Power supply to the unit must be N.E.C. Class 1, and must comply with all applicable codes. A fused disconnect switch should be field provided for the unit. The switch must be separate from all other circuits.

WARNING

Unit must be grounded in accordance with national and local codes. Failure to ground unit properly can result in personal injury or death.

Electrical Access

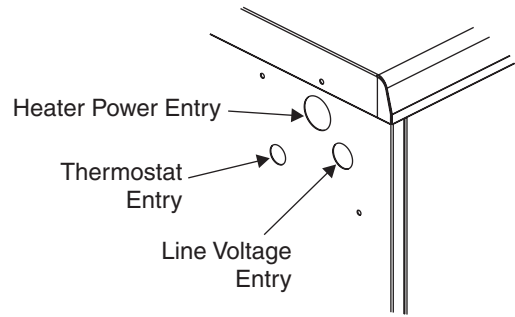
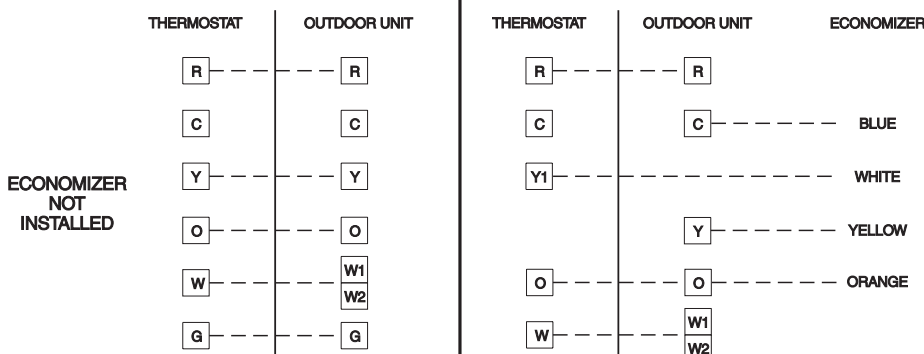

Figure 5

If any of the wire supplied with the unit must be replaced, replacement wire must be of the type shown on the wiring diagram. Electrical wiring must be sized to carry minimum circuit ampacity marked on the unit. **Use copper conductors only.** Each unit must be wired with a separate branch circuit and be properly fused.

Typical Wiring Connections



CAUTION

Do not connect **C** connections except when required by the indoor thermostat. Refer to the thermostat installation instructions.

CAUTION

Do not connect **C** connections except when required by the indoor thermostat. Refer to the thermostat installation instructions.

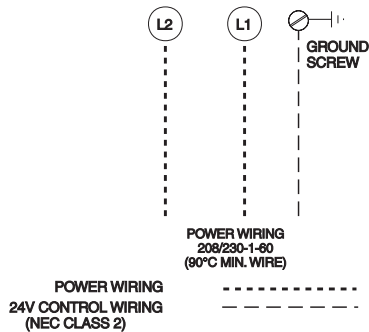

* W1, W2 CAN BE USED TO STAGE ELECTRIC HEAT ACCESSORY ON 15, 20 & 25 KW MODELS.
* 5 & 10 KW HEATER ACCESSORY FUNCTION OFF W1 ONLY.

TYPICAL WIRING CONNECTION 1 PHASE

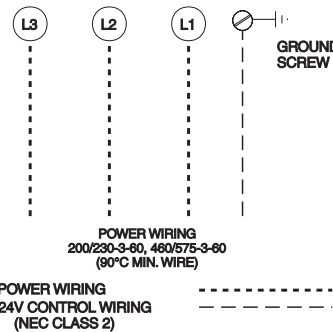

* W1, W2 CAN BE USED TO STAGE ELECTRIC HEAT ACCESSORY ON 15, 20 & 25 KW MODELS.
* 10 KW HEATER ACCESSORY FUNCTION OFF W1 ONLY.

TYPICAL WIRING CONNECTION 3 PHASE

Figure 6

Thermostat

The room thermostat should be located on an inside wall where it will not be subject to drafts, sun exposure, or heat from electrical fixtures or appliances. Follow the manufacturer's instructions enclosed with thermostat for general installation procedure. Color-coded insulated wires (#18 AWG) should be used to connect thermostat to unit. Four wires are required for cooling.

Compressor

Units are shipped with compressor mountings factory-adjusted and ready for operation. **Caution: Do not loosen compressor mounting bolts.**

Heater Kit Accessory (if used)

The unit is fully equipped for cooling operation without auxiliary heat. A heater kit accessory may also be used.

To install the heater kit accessory (see Figure 7):

1. Disconnect the power and remove the heater compartment access panel.
2. Disconnect the plug separating the high voltage wire harness. Remove the high voltage wire harness plug and discard.
3. Remove the heater blockoff by removing the four screws holding it in place.
4. Insert the heater into the control panel and fasten in the same mounting holes.
5. Plug the heater wiring harness into the wire harness on the control assembly. Field wiring of the auxiliary heater is separate from the unit power supply. Wire the power supply wiring for the heater to the appropriate connections on the heater kit.
6. Replace the heater compartment access panel and reconnect the power.

Removal of Unit from Common Venting System

When an existing furnace is removed from a common venting system serving other appliances, the venting system is likely to be too large to properly vent the remaining attached appliances. The following test should be conducted with each appliance while the other appliances connected to the common venting system are not in operation.

1. Seal any unused openings in the common venting system.
2. Visually inspect the venting system for proper size and horizontal pitch and determine there is no block-

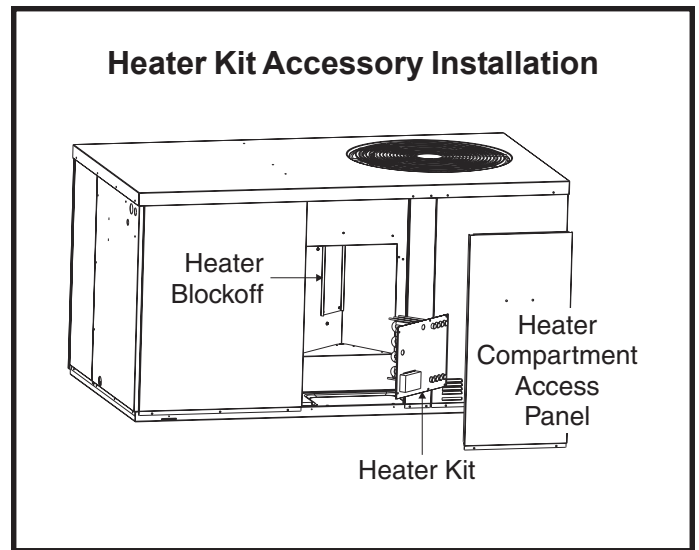

Figure 7

age or restriction, leakage, corrosion, or other deficiencies which could cause an unsafe condition.

3. Insofar as is practical, close all building doors and windows between the space in which the appliances remaining connected to the common venting system are located and other spaces in the building. Turn on clothes dryers and any appliance not connected to the common venting system. Turn on exhaust fans, such as range hoods and bathroom exhausts, so they will operate at maximum speed. Do not operate a summer exhaust fan. Close fireplace dampers.
4. Following the lighting instructions, place the unit being inspected in operation. Adjust the thermostat so the appliance will operate continuously.
5. Test for spillage at the draft control relief opening after 5 minutes of main burner operation. Use the flame of a match or candle.
6. Follow the preceding steps for each appliance connected to the common venting system.
7. After it has been determined that each appliance remaining connected to the common venting system properly vents when tested as outlined above, return doors, windows, exhaust fans, fireplace dampers, and any other fuel burning appliance to their previous condition of use.
8. If improper venting is observed during any of the above tests, the common venting system must be corrected. **See National Fuel Gas Code, ANSI Z223.1 (latest edition) or CAN/CGA B149.1 & .2 Canadian Installation Codes to correct improper operation of common venting system.**

OPERATION

Sequence of Operation

Cooling

When the thermostat is in the cooling mode, the O circuit is powered which energizes the reversing valve. Upon cooling demand, the thermostat closes circuit R and Y. Closing R and Y closes the unit contactor, starting the compressor and outdoor fan. The thermostat automatically closes R to G circuit which also brings on the indoor blower at the same time. Upon satisfying cooling demand, the thermostat will open the above circuits and open the main contactor, stopping the compressor and outdoor fan. If the unit is equipped with a delay timer, the blower will continue to operate for 90 seconds which improves system efficiency.

Heating

Upon heating demand, the thermostat closes circuit R to Y, which closes the unit contactor, starting the compressor and outdoor fan. The reversing valve is not energized in the heating mode. The thermostat again automatically brings on the indoor fan at the same time. Upon satisfying heating demand, the thermostat opens above circuits and stops unit operation.

Defrost System

The defrost system includes two components: the defrost thermostat and the defrost control.

Defrost Thermostat

The defrost thermostat is located on the liquid line between the check/expansion valve and the distributor. When the defrost thermostat senses 42°F or cooler, the thermostat contacts close and send a signal to the defrost control board to start the defrost timing. It also terminates defrost when the liquid line warms up to 70°F.

Defrost Control

The defrost control board includes the combined functions of time/temperature defrost control, defrost relay, diagnostic LEDs and terminal strip for field wiring connections (see Figure 8).

The control provides automatic switching from normal heating operation to defrost mode and back. During the compressor cycle (call for defrost), the control accumulates compressor run time at 30, 60, 90 minute field-adjustable intervals. If the defrost thermostat is closed when the selected compressor run time interval ends, the defrost relay is energized and the defrost begins.

Defrost Control Timing Pins

Each timing pin selection provides a different accumulated compressor run time period during one thermostat run cycle. This time period must occur before a defrost cycle is initiated. The defrost interval can be adjusted to 30 (T1), 60 (T2), or 90 (T3) minutes. The defrost timing jumper is factory installed to provide a 60-minute defrost interval. If

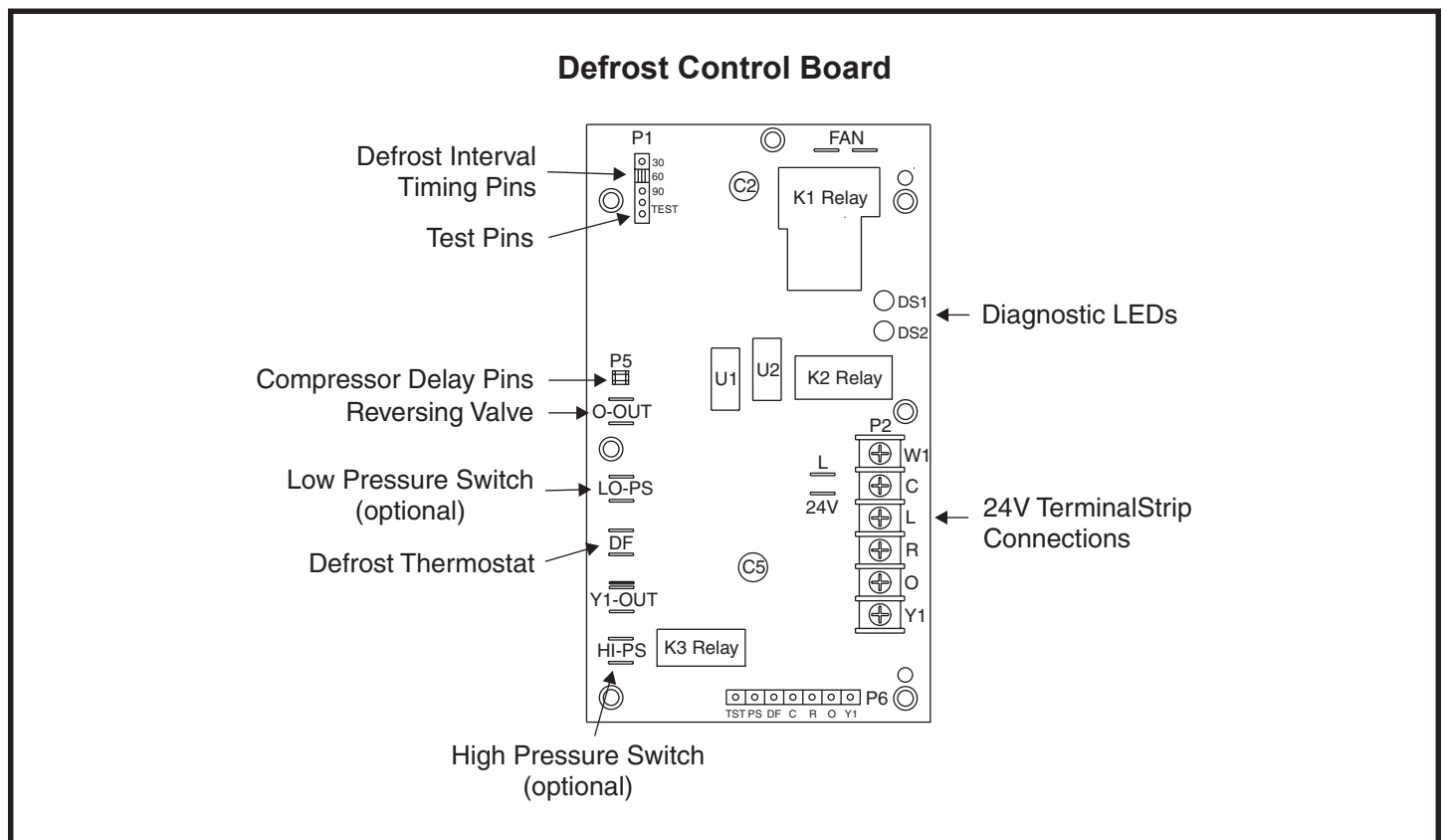

Figure 8

the timing selector jumper is not in place, the control defaults to a 90-minute defrost interval. The maximum defrost period is 14 minutes and cannot be adjusted.

A test option is provided for troubleshooting. The test mode may be started any time the unit is in the heating mode and the defrost thermostat is closed or jumpered. If the jumper is in the TEST position at power up, the control will ignore the test pins. When the jumper is placed across the TEST pins for 2 seconds, the control will enter the defrost mode. If the jumper is removed before an additional 5-second period has elapsed (7 seconds total), the unit will remain in defrost mode until the defrost thermostat opens or 14 minutes have passed. If the jumper is not removed until after the additional 5-second period has elapsed, the defrost will terminate and the test option will not function again until the jumper is removed and reapplied.

Compressor Delay

The defrost board has a field-selectable function to reduce occasional sounds that may occur while the unit is cycling in and out of the defrost mode. The compressor will be cycled off for 30 seconds going in and out of the defrost mode when the compressor delay jumper is removed.

NOTE: The 30-second “off” cycle is not functional when jumpering the TEST pins.

Time Delay

The timed-off delay is 5 minutes long. The delay helps to protect the compressor from short cycling in case the power to the unit is interrupted or a pressure switch opens. The delay is bypassed by placing the timer select jumper across the TEST pins for 0.5 seconds.

Pressure Switch Circuit

The defrost control includes LO-PS terminals to connect an optional low pressure (loss of charge pressure) switch. A high pressure switch (optional) can be connected to the HI PS terminals (see Figure 8 on page 7).

During a single demand cycle, the defrost control will lock out the unit after the fifth time that the circuit is interrupted by any pressure switch wired to the control board. In addition, the diagnostic LEDs will indicate a locked-out pressure switch after the fifth occurrence of an open pressure switch (see Table 3). The unit will remain locked out until power to the board is interrupted, then re-established, or until the jumper is applied to the TEST pins for 0.5 seconds.

NOTE: The defrost control board ignores input from the low pressure switch terminals as follows:

- During the TEST mode
- During the defrost cycle

- During the 90-second start-up period
- For the first 90 seconds each time the reversing valve switches heat/cool modes

If the TEST pins are jumpered and the 5-minute delay is being bypassed, the LO PS terminal signal is not ignored during the 90-second start-up period.

Diagnostic LEDs

The defrost board uses two LEDs for diagnostics. The LEDs flash a specific sequence according to the condition as shown in Table 3.

Mode	Green LED (DS2)	Red LED (DS1)
No Power to Board	Off	Off
Normal Operation/ Power to Board	Simultaneous Slow Flash	
Anti-Short Cycle Lockout	Alternating Slow Flash	
Low Pressure Switch Fault	Off	Slow Flash
Low Pressure Switch Lockout	Off	On
High Pressure Switch Fault	Slow Flash	Off
High Pressure Switch Lockout	On	Off

Table 3

Circulating Air Blower

The circulating air blower is controlled by a timing circuit in the blower control. Timings are not adjustable.

There is no blower “on” delay after a call for heating or cooling. Blower “off” delay is 90 seconds after the thermostat is satisfied.

Cooling System Performance

For maximum performance of the cooling system, operating temperatures and pressure should be checked. Subcooling should be determined at Standard ARI test conditions of 82°F outdoor and 80°F indoor dry bulb/67°F wet bulb. If subcooling measured deviates from values found in Table 4, refrigerant charge should be adjusted accordingly for maximum performance.

Size	Liquid Subcooling @ ARI Conditions 82° OD - 80° IDDB/67° IDWB	
	R22	410A
24	10°	9°
30	8°	11°
36	10°	11°
42, 48	5°	7°
60	10°	10°

Table 4

MAINTENANCE

WARNING

ELECTRICAL SHOCK, FIRE, OR EXPLOSION HAZARD

Failure to follow the safety warnings exactly could result in dangerous operation, serious injury, death, or property damage.

Improper servicing could result in dangerous operation, serious injury, death, or property damage.

- Before servicing, disconnect all electrical power to unit.
- When servicing controls, label all wires prior to disconnecting. Reconnect wires correctly.
- Verify proper operation after servicing.

Periodic inspection and maintenance normally consists of changing or cleaning the filters and cleaning the outdoor coil. On occasion, other components may also require cleaning.

Filters

Filters should be checked at least every 6 weeks. Disposable filters should be replaced when dirty, and cleanable filters should be cleaned regularly. It is important to keep the air filters clean, as dirty filters can restrict airflow and the blower motor depends upon sufficient air flowing across and through it to keep from overheating.

Motors

Indoor and outdoor fan and vent motors are permanently lubricated and require no maintenance.

Outdoor Coil

Dirt and debris should not be allowed to accumulate on the outdoor coil surface or other parts in the air circuit. Cleaning should be as often as necessary to keep coil clean. Use a brush, vacuum cleaner attachment, or other suitable means. If water is used to clean the coil, be sure the power to unit is shut off prior to cleaning. **Care should be used when cleaning the coil so that the coil fins are not damaged.**

Do not permit the hot condenser air discharge to be obstructed by overhanging structures or shrubs.

Owner Record

Model # _____

Serial # _____

Installation Date _____

Installed by: _____

Dealer _____

Address _____

Telephone # _____

License # _____

BLOWER SPEED CHART

Unit	Factory Shipped Settings
Cooling Input	(BLK)
24	LOW
30	MED
36	HIGH
42	LOW
48	MED
60	HIGH

DIAGNOSTIC DISPLAY

Mode	Green LED (DS2)	Red LED (DS1)
No Power to Board	Off	Off
Normal Operation/ Power to Board	Simultaneous Slow Flash	
Anti-Short Cycle Lockout	Alternating Slow Flash	
Low Pressure Switch Fault	Off	Slow Flash
Low Pressure Switch Lockout	Off	On
High Pressure Switch Fault	Slow Flash	Off
High Pressure Switch Lockout	On	Off

Note: Because the pressure switches are monitored only when "Y1" (Input) is active, the code for pressure switch open will not be seen when "Y1" is off. Instead, the "Normal Operation" or "Anti-Short Cycle Lockout" code will be seen.

When a pressure switch opens and causes a short cycle lockout, the pressure switch-open code will be seen until it closes, then the short cycle lockout code will flash unless it has already expired.

Wiring Diagram
P/N 48349-001

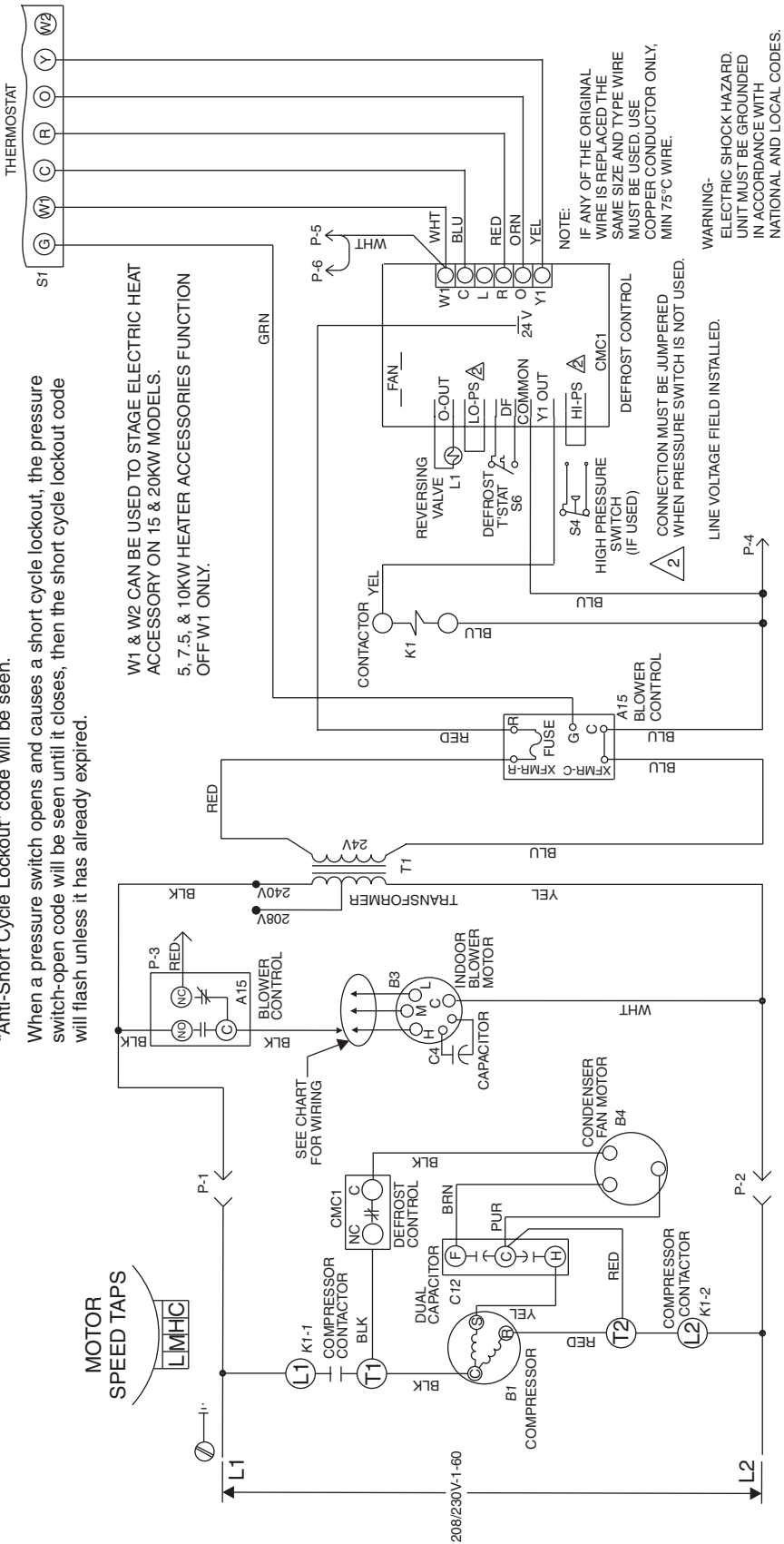

Limited Warranty

August 1, 1997

This warranty gives you specific legal rights and you may have other rights which vary from state/province to state/province.

Subject to the limitations stated in this warranty, we warrant to the first buyer for use the residential heating, cooling, or heat pump unit, when installed, operated, and maintained as required by this warranty, to be free of defects in workmanship or material for a period of 5 years in residential installations (1 year in non-residential installations) from the time of installation. We will replace any defective component without cost or expense to you except for the costs of delivery and labor for removal and replacement of the defective component.

These (2/4)SH13 package heat pump units carry a 5-year limited warranty on the compressor. Limited warranties apply to the original owner in private owner-occupied residences.

Warranty Begins

The warranty period begins when the installation is complete and the product is ready to operate. You must be able to verify this date whenever a warranty claim is made. Original bill of sale, installer's invoice, or other similar document will suffice. If the beginning date cannot be verified, we will consider warranty coverage to begin 6 months after the date the product was shipped from our factory.

Limitations on Implied Warranties

Implied warranties of merchantability or, to the extent applicable, fitness for a particular purpose are limited to 5 years, the same duration as the basic limited written warranty provided herein. Some states/provinces do not allow limitations on how long an implied warranty of merchantability or fitness lasts, so the above limitations or exclusions may not apply to you.

Only Warranty

This written Limited Warranty is the only warranty made by the warrantor; this warranty is in lieu of and excludes all other warranties, express or implied. The warrantor does not authorize any person to provide any other warranty or to assume for it any further obligation in connection with the warranted product.

What is NOT Covered

1. Cabinets or cabinet pieces.
2. Normal maintenance items such as filters, fan belts, fuses, or other consumable items.
3. Damage caused by misuse, failure to maintain properly, accidents, or acts of God.
4. External wiring, piping, venting, or attachment of accessory products not integral to our product, including without limitation, humidifier, air cleaner, vent damper, thermostat, or other mechanical devices not manufactured by the warrantor.
5. Products that have been operated in a corrosive atmosphere where a concentration of acids, halogenated hydrocarbons, or other corrosive elements causes deterioration to metal surfaces or integral components. NOTE: Operation in a corrosive atmosphere is considered abuse and voids this warranty.
6. Products that have NOT been installed in accordance with our published installation instructions, applicable local, state/provincial, or national codes, ACCA published standards.
7. Products that have NOT been installed by competent, qualified installers.
8. Products that have been moved from their original place of installation.

Warranty on Replacement Components

Any replacement component furnished by us will assume the remaining (unused) portion of the Limited Warranty.

Consequential Damages

The warrantor shall not be responsible for any consequential damages caused by any defect in the product. Some state/provinces do not allow the exclusion or limitations of incidental or consequential damages, so the above limitation or exclusion may not apply to you.

This product must be installed, used, and cared for in accordance with the instruction manual. You are responsible for required periodic maintenance or service, such as changing or cleaning of air filters and lubrication or cleaning of components. Failure to properly install, operate, or maintain your unit voids this warranty.

Free Manuals Download Website

<http://myh66.com>

<http://usermanuals.us>

<http://www.somanuals.com>

<http://www.4manuals.cc>

<http://www.manual-lib.com>

<http://www.404manual.com>

<http://www.luxmanual.com>

<http://aubethermostatmanual.com>

Golf course search by state

<http://golfingnear.com>

Email search by domain

<http://emailbydomain.com>

Auto manuals search

<http://auto.somanuals.com>

TV manuals search

<http://tv.somanuals.com>