



Cross-Cut Paper Shredder

DX-PS06CC

USER GUIDE

Download from www.Somanuals.com. All Manuals Search And Download.
Before using your new product, please read these instructions to prevent any damage.

Cross-Cut Paper Shredder

Contents

Important safety instructions.....	2
Features	4
Package contents	4
Setting up the shredder	6
Using the shredder	6
Maintaining	7
Troubleshooting.....	8
Specifications.....	9
One-year limited warranty.....	11

Important safety instructions

- 1 Read these instructions.
- 2 Keep these instructions.
- 3 Heed all warnings.
- 4 Follow all instructions.
- 5 Keep out of reach of children and pets.
- 6 Do not use this unit near water.
- 7 Clean only with dry cloth. The housing can be cleaned with a cloth dampened with mild soap and water, then dried thoroughly.
- 8 Do not defeat the safety purpose of the polarized plug. A polarized plug has two blades with one wider than the other. The wide blade is provided for your safety. If the provided plug does not fit into your outlet, consult an electrician for replacement of the obsolete outlet.
- 9 Protect the power cord from being walked on or pinched particularly at plugs, convenience receptacles, and the point where they exit from the apparatus.
- 10 The *wall plug* is the disconnecting device. The plug must remain readily operable.
- 11 **RISK OF FIRE.** Never use any petroleum based or flammable oils or lubricants in or around the machine as some oils can combust causing serious injury.

- 12 NEVER dispose of flammable chemicals or materials that have come into contact with flammable chemicals (for example, nail polish, acetone, gasoline) in the shredder basket.
- 13 Never shred plastic (except credit cards), any hard materials, continuous forms, newsprint, or anything with adhesives including labels and envelopes.
- 14 Do not activate the reverse function while shredding credit cards.
- 15 Plug the shredder into a nearby, easily accessible power outlet.
- 16 Always turn the shredder off and unplug the power cord from the AC outlet before cleaning it, moving it, or emptying the wastebasket.
- 17 Never let the wastebasket become full. This will lead to shredded material being pulled back up into the shredder and cause jams.
- 18 Never place the shredder near water or any heat source.
- 19 Keep the wastebasket emptied so that the shredder output is not impeded.
- 20 Do not use the shredder if the power cord is damaged in any way.
- 21 Do not attempt to service this product yourself as doing so may expose you to sharp cutting blades and/or electricity and will void the manufacturers warranty.
- 22 Never try to clean the shredder blade.
- 23 Never shred beyond the specified sheet capacity. May result in extensive damage to the machine.
- 24 Operate the shredder from the power source specified on the label. If you are unsure about the power source, contact an electrician.
- 25 If an extension cord is used, make sure that the total amp rating of the products plugged into the extension cord do not exceed the extension cord amp rating and that the total of all products plugged into the wall out do not exceed 15 amps.



Warning: To avoid injury to yourself and others, please follow safety instructions before operating this device.



Read instructions before use.



Avoid touching the document feed opening with your hands. Never insert your hand or fingers into the feed opening.



Product is not intended for use by children (product is not a toy).



Do not insert foreign objects into the document feed opening.



Do not spray or keep any aerosol products in or around shredder.



Avoid loose clothing or jewelry touching the document feed opening.



Do not shred paper with paperclips or staples. Do not shred gummed or wet paper.



Shred paper and credit cards only. No cardboard, plastic sheets, or CD/DVDs.



Do not exceed the shredders maximum capacity of six sheets.



Always unplug the unit when not in use to prevent accidents.



Do not operate the unit with a damaged power cord.



Do not shred continuously for more than two minutes.



Avoid getting your hair or face near the document feed opening. Do not let hair touch the document feed opening. Serious injury may result.

Features

- 6-sheet capacity (20-lb paper) (**Note:** One folded sheet is equivalent to two sheets.)

Package contents

- Wastebasket
- Shredder head
- *User Guide*

Shredder details

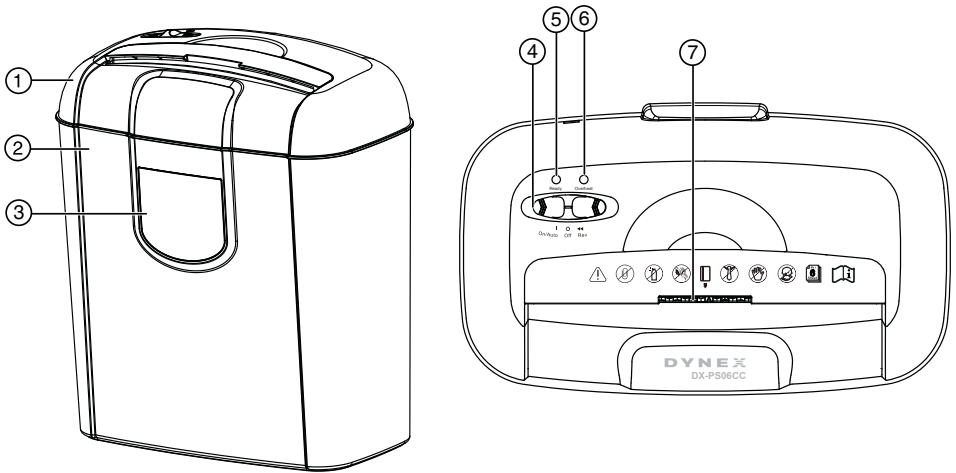

#	Feature	Description
1	Shredder head	Contains the control panel and the cutting head.
2	Waste basket	Shredded paper goes into this basket. Keep emptied.
3	Clear window	Empty the waste basket when the shredded paper reaches 2/3 of capacity.
4	Switch	A three-position slide switch for On/Auto, Off, and Rev.
5	Ready LED indicator	Lights green when the power is on.
6	Overheat LED indicator	Lights red when the shredder is overheated.
7	Feed opening	Put paper (maximum of six sheets) or credit cards into this opening to shred.

Setting up the shredder

Warning: Crosscut shredders have very sharp exposed blades on the underside. Use care when mounting the shredder on the wastebasket.

Caution: The shredder should not be plugged in during assembly.

Note: The following illustrations are for information purposes only. Your actual shredder may look somewhat different than the shredder shown.

To set up the shredder:

- 1 Position the shredder head over the basket.

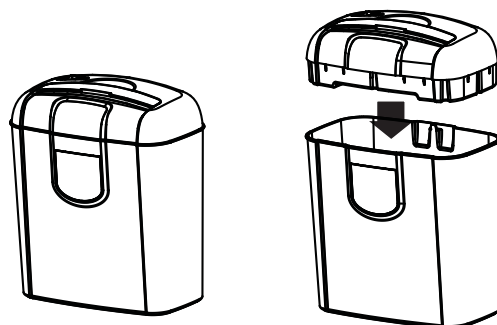

- 2 Place the shredder head on the basket so that it solidly rests on the basket edges.



Note: Always make sure that these two labels are aligned on the same side of the shredder when you place the shredder head onto the basket. This shredder has a safety interlock which prevents it from operating unless the shredder head is placed on the basket correctly.

Using the shredder

Note: Prepare paper to be shredded by removing staples and paper clips from the paper. Make sure that each batch of paper does not exceed the recommended capacity of six sheets.

To use the shredder:

Caution:

- **Do not overfeed the shredder:** Shredding beyond the specified sheet capacity can result in extensive damage to the shredder. Overfeeding will strain the machine and quickly wear and break the cutting blades and internal components.

- 1 Plug in the power cord.

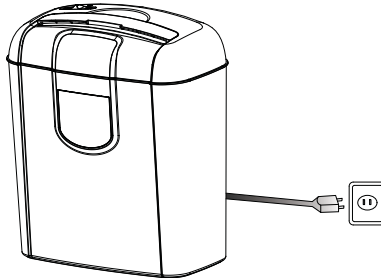

- 2 To begin shredding, locate the switch on the top of the shredder and select the On/Auto mode. The green power LED indicates the shredder is on and ready to use.
Caution: *Never shred paper clips, window or insulated envelopes, continuous forms, newsprint, transparencies, laminated documents, cardboard, any items with adhesives, hard materials, or plastic (except credit cards).*
- 3 Slide the paper or credit card into the feed opening. The shredder automatically starts after the paper or credit card has been inserted. The shredder stops automatically when it has finished shredding.

Maintaining

Caution: *Failure to properly maintain your shredder will void the warranty.*

- Crosscut shredders require regular oil lubrication for optimal performance and extended lifespan. We recommend you oil your shredder once a month. To lubricate your shredder, drizzle some basic vegetable or cooking oil (nothing flammable or petroleum based) onto a few sheets of paper and feed it into the shredder.
- Do not spray or keep any aerosol products in or around shredder.
- DO NOT USE CANNED AIR ON THE SHREDDER.
- Be sure to periodically empty the wastebasket to avoid overloading and damaging the cutting mechanism.

To clean the shredder:

- ALWAYS UNPLUG THE SHREDDER BEFORE CLEANING!
- Only clean the shredder by carefully wiping the unit with a soft cloth or towel moistened with mild soap and water. Dry the unit thoroughly.
- Do not clean or immerse the shredder in water. Having the unit wet may result in damage or malfunction to the electrical components. If the shredder happens to get wet, be sure to completely dry the unit immediately with a cloth or towel.
- Never use anything flammable to clean the shredder. This may result in serious injury or damage to the product.

Troubleshooting

If there is a problem with your shredder, check below for the symptoms and steps to resolve. If you continue to have problems, contact customer support at our Service Center. **DO NOT ATTEMPT TO REPAIR BY OPENING THE SHREDDER HEAD.** This will completely void the product warranty.

Symptom	Possible Solutions
The shredder does not work at all.	<ul style="list-style-type: none"> • Make sure that the shredder is plugged in and that the outlet it is plugged into is in good working order. • The shredder may overheat with extended use. In the event that the shredder has shred continuously beyond the maximum running time and has overheated, the shredder will automatically shut off. If this happens, switch the shredder off for 30 minutes or longer before resuming normal operation. • If using a plastic bag to line the wastebasket, remove it. The bag may be the cause of the shredder not operating properly. • The activation sensor of the shredder is located near the center of the feed slot. Be sure to feed directly into the center area to trigger the machine (especially applies to smaller pieces of paper or credit cards).
The shredder runs in Rev mode but not in On/Auto mode.	<ul style="list-style-type: none"> • While in On/Auto mode, the motor will not start running until paper is inserted into the feed slot. Set the unit to On/Auto and insert the paper to be shredded. It is normal for the motor to run for a moment after setting it to On/Auto but it should stop until paper is inserted. The sensor that activates the shredder in On/Auto mode is located directly in the center of the slot. If the paper you are inserting is narrow, it may not be detected by the sensor. It is possible that the sensor, which activates the shredder, has become blocked with paper. Insert an index card, directly in the center of the feed slot, and apply force. This will usually clear any paper blocking the sensor.
There is a paper jam in the shredder.	<ul style="list-style-type: none"> • Switch the shredder over into Rev (reverse) mode. While in reverse, the shredder will back up and loosen the jammed paper. If required, you may need to tug and remove several sheets to effectively clear the machine. When jammed paper is loosened or removed, switch back to the On/Auto mode to continue shredding. Repeat steps if needed. • CAUTION: Keep your hands away from the feed opening. • With stubborn situations where the reverse function does not help, you may loosen the jammed paper with shredder oil (cooking oil is acceptable, nothing aerosol). Start by drizzling oil into the blades where the paper is jammed. Let it soak for about 30 minutes to completely saturate. Return the shredder back to On/Auto mode. If required, a rigid sheet of cardstock (old greeting card, folded file folder, or a sheet torn from a cereal box) can be fed into the shredder to help push the jammed paper through.
The shredder will not stop running.	<ul style="list-style-type: none"> • The sensor that activates the shredder may be blocked. Insert a sheet of paper to clear the sensor.

Specifications

Product dimensions	14.3 in H x 12.5 in W x 7.3 in D (36.2cm x 31.8cm x 18.5cm)
Duty cycle	2 minutes ON / 30 minutes OFF
Sheet capacity	Six sheets of 20 lb. bond paper (one folded sheet of paper equals two sheets of paper.)
Paper shred size	0.19 x 1.34 in (5 x 34 mm)
Paper entry width	8.8 in (225 mm)
Credit card capacity	One at a time
Power source	US - AC 120V, 60Hz, 1.5 A
Basket capacity	3.5 gal. (12 L)

One-year limited warranty

Dynex Products ("Dynex") warrants to you, the original purchaser of this new **DX-PS06CC** ("Product"), that the Product shall be free of defects in the original manufacture of the material or workmanship for a period of one (1) year from the date of your purchase of the Product ("Warranty Period"). This Product must be purchased from an authorized dealer of Dynex brand Products and packaged with this warranty statement. This warranty does not cover refurbished product. If you notify Dynex during the Warranty Period of a defect covered by this warranty that requires service, terms of this warranty apply.

How long does the coverage last?

The Warranty Period lasts for one year (365 days) from the date you purchased the Product. The purchase date is printed on the receipt you received with the Product.

What does this warranty cover?

During the Warranty Period, if the original manufacture of the material or workmanship of the Product is determined to be defective by an authorized Dynex repair center or store personnel, Dynex will (at its sole option): (1) repair the Product with new or rebuilt parts; or (2) replace the Product at no charge with new or rebuilt comparable products or parts. Products and parts replaced under this warranty become the property of Dynex and are not returned to you. If service of products and parts are required after the Warranty Period expires, you must pay all labor and parts charges. This warranty lasts as long as you own your Dynex Product during the Warranty Period. Warranty coverage terminates if you sell or otherwise transfer the Product.

How to obtain warranty service?

If you purchased the Product at a retail store location, take your original receipt and the Product to the store you purchased it from. Make sure that you place the Product in its original packaging or packaging that provides the same amount of protection as the original packaging. If you purchased the Product from an online web site, mail your original receipt and the Product to the address listed on the web site. Make sure that you put the Product in its original packaging or packaging that provides the same amount of protection as the original packaging.

To obtain in-home warranty service for a television with a screen 25 inches or larger, call 1-888-BESTBUY. Call agents will diagnose and correct the issue over the phone or will have an Dynex-approved repair person dispatched to your home.

Where is the warranty valid?

This warranty is valid only to the original purchaser of the Product in the United States, Canada, and Mexico.

What does the warranty not cover?

This warranty does not cover:

- Customer instruction
- Installation
- Set up adjustments
- Cosmetic damage
- Damage due to acts of God, such as lightning strikes
- Accident
- Misuse
- Abuse
- Negligence
- Commercial use
- Modification of any part of the Product
- Plasma display panel damaged by static (non-moving) images applied for lengthy periods (burn-in).

This warranty also does not cover:

- Damage due to incorrect operation or maintenance
- Connection to an incorrect voltage supply
- Attempted repair by anyone other than a facility authorized by Dynex to service the Product
- Products sold as is or with all faults

- Consumables, such as fuses or batteries
- Products where the factory applied serial number has been altered or removed

REPAIR REPLACEMENT AS PROVIDED UNDER THIS WARRANTY IS YOUR EXCLUSIVE REMEDY. DYNEX SHALL NOT BE LIABLE FOR ANY INCIDENTAL OR CONSEQUENTIAL DAMAGES FOR THE BREACH OF ANY EXPRESS OR IMPLIED WARRANTY ON THIS PRODUCT, INCLUDING, BUT NOT LIMITED TO, LOST DATA, LOSS OF USE OF YOUR PRODUCT, LOST BUSINESS OR LOST PROFITS. DYNEX PRODUCTS MAKES NO OTHER EXPRESS WARRANTIES WITH RESPECT TO THE PRODUCT, ALL EXPRESS AND IMPLIED WARRANTIES FOR THE PRODUCT, INCLUDING, BUT NOT LIMITED TO, ANY IMPLIED WARRANTIES OF AND CONDITIONS OF MERCHANTABILITY AND FITNESS FOR A PARTICULAR PURPOSE, ARE LIMITED IN DURATION TO THE WARRANTY PERIOD SET FORTH ABOVE AND NO WARRANTIES, WHETHER EXPRESS OR IMPLIED, WILL APPLY AFTER THE WARRANTY PERIOD. SOME STATES, PROVINCES AND JURISDICTIONS DO NOT ALLOW LIMITATIONS ON HOW LONG AN IMPLIED WARRANTY LASTS, SO THE ABOVE LIMITATION MAY NOT APPLY TO YOU. THIS WARRANTY GIVES YOU SPECIFIC LEGAL RIGHTS, AND YOU MAY ALSO HAVE OTHER RIGHTS, WHICH VARY FROM STATE TO STATE OR PROVINCE TO PROVINCE.

Contact Dynex:

For customer service please call 1-800-305-2204 (U.S. and Canada) or 01-800-926-3020 (Mexico)
www.dynexproducts.com

Distributed by Best Buy Purchasing, LLC

7601 Penn Avenue South, Richfield, Minnesota, U.S.A. 55423-3645

© 2013 BBY Solutions, Inc.

All rights reserved. DYNEX is a trademark of BBY Solutions, Inc. Registered in some countries. All other products and brand names are trademarks of their respective owners.

DYNEX™

www.dynexproducts.com
1-800-305-2204 (U.S. and Canada) or 01-800-926-3020 (Mexico)

Distributed by Best Buy Purchasing, LLC
7601 Penn Ave. South, Richfield, MN 55423 U.S.A.
© 2013 BBY Solutions, Inc. All rights reserved.

DYNEX is a trademark of BBY Solutions, Inc. Registered in some countries.
All other products and brand names are trademarks of their respective owners.

V2 ENGLISH 13-0652

Free Manuals Download Website

<http://myh66.com>

<http://usermanuals.us>

<http://www.somanuals.com>

<http://www.4manuals.cc>

<http://www.manual-lib.com>

<http://www.404manual.com>

<http://www.luxmanual.com>

<http://aubethermostatmanual.com>

Golf course search by state

<http://golfingnear.com>

Email search by domain

<http://emailbydomain.com>

Auto manuals search

<http://auto.somanuals.com>

TV manuals search

<http://tv.somanuals.com>