



Dynex ATX 400 and ATX 520 Watt Power Supplies
DX-400WPS/DX-520WPS

USER GUIDE

Before using your new product, please read these instructions to prevent any damage.
Download from www.Somanuals.com. All Manuals Search And Download.

Dynex ATX 400 Watt and ATX 520 Watt Power Supplies

Contents

Introduction	1
Safety information	1
Power supply components and features	1
Package contents	1
Installing the power supply	2
Connector types	3
Troubleshooting	4
Specifications	4
Legal notices	4
One-year limited warranty - Dynex	5

Introduction

Congratulations on your choice of this Dynex DX-400WPS or Dynex DX-520WPS power supply. Please read this manual carefully and follow the instructions before installing the power supply.

This is an advanced power supply with excellent acoustic and thermal performance and intelligent thermal fan control technology that makes it virtually silent. The power supply provides perfect protection for your system and comes equipped with two +12V rails that can handle a maximum load of 18A for additional system reliability.

Safety information

Safety regulations

The power supply meets safety guidelines and regulations for UL, cUL, and FCC.



Important safety instructions

- Do not place your system near a radiator or other heat source.
- Do not place your system close to a source of strong magnetic fields.
- Do not place your system in a moist or dusty environment, or in an area subject to strong vibration.
- Do not place your system in direct sunlight.
- Your computer must operate at a stable AC input voltage.
- Your computer should not be situated directly next to a heater or another heat source.
- Do not open the cover on the power supply case. Dangerous voltages are present inside the cover. Your warranty is void if the cover is removed.
- Never operate the device with wet or moist hands.
- Never place items in the openings or fan of the power supply.
- Make sure that the power cord is plugged into a powered electrical outlet.
- Make sure that the power cord is plugged into the power supply.
- Make sure that you connect your power supply properly. Check your motherboard and graphic card manuals for compatibility before connecting the power supply to any of your devices.

Caution (for DX-400WPS only): Check the red power supply voltage switch setting before installation. The setting should be the same as your local power voltage (115 V for North America and 230 V for Europe and other countries). Change the voltage setting if necessary. Failure to take this precaution could result in damage to your equipment and could void your warranty.

Note: If the power supply does not work correctly, contact our service center immediately at (800) 305-2204.

Power supply components and features

Power supply features include:

- Complies with the newest Intel standard ATX 12V version 2.31 and is downward compatible with V2.2 and V2.0
- Supports Intel and AMD dual-core and multi-core processors
- High-performance components designed for better reliability
- Dual +12 V outputs for higher power capacity
- One 4+4 pin +12 V CPU connector for high-end CPUs
- One 6+2 pin PCI Express connector for high-end video cards
- 140 mm low-noise cooling fan
- All DC cables are mesh-sleeved. The length is 15.75 in. (40 cm)
- High reliability, including built-in protection circuit OVP, OLP, SCP, and line input fuse protection

Power supply components include:

DX-400WPS power supply

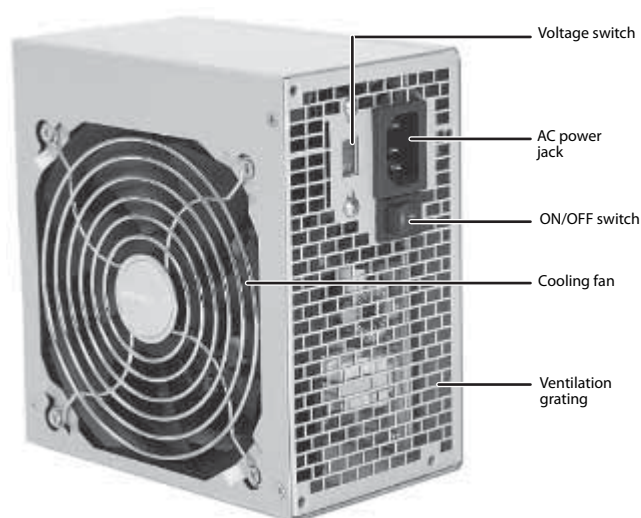

DX-520WPS power supply

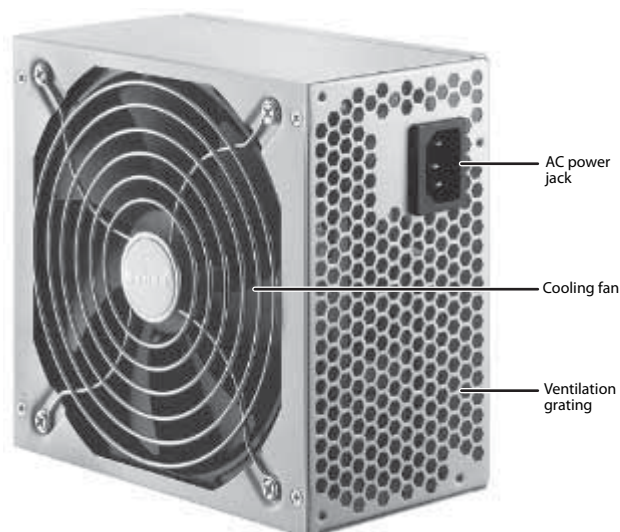

Package contents

- 400-Watt or 520-Watt ATX Power Supply
- AC power cord
- User Guide

Installing the power supply

Preparing your power supply:

- 1 Make sure your motherboard, graphics card, and other components are compatible with this power supply. Refer to the documentation that came with each component.
- 2 Check your local AC voltage (115 VAC for USA, Canada, Japan, and others, and 230 VAC for Europe, Southeast, Asia, and others). **The DX-520WPS is only compatible with 115 VAC.**
- 3 For DX-400WSP only: Make sure that the red voltage switch (located on the back of the power supply) is set to the correct voltage setting.

Caution: Using the incorrect voltage can damage the power supply and connected equipment and may void your warranty.

Are you replacing a power supply?

- Yes, start at "Removing your old power supply" below.
- No, go to "Installing your power supply" on pg 2.

Removing your old power supply:

- 1 Turn off your computer.
- 2 Unplug the power cord from your computer.
- 3 Open your computer case. (See the instructions that came with your computer.)
- 4 Disconnect your old power supply from all computer components.

Tip: Make sure to note each component and the connector type for when you need to connect them to your new power supply.

- 5 Remove the screws that secure your old power supply to your computer case, then remove it from the case.

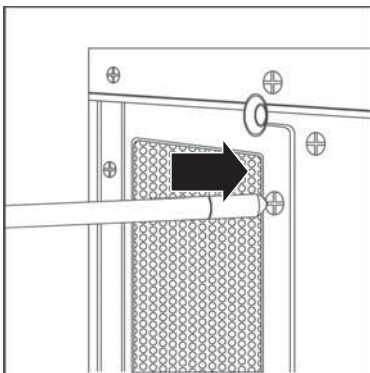

Installing your power supply:

- 1 Position your power supply in the computer case, making sure that the AC power jack and cooling fan are facing out, then secure your power supply using the screws included with your computer case.
- 2 Connect all power supply cables. Make sure that each connection is secure.

Tip: If you are replacing an old power supply, reference your notes from when you removed the old power supply to make sure you are connecting all of your components correctly.

- a. Connect the 20+4-pin main power connector to your motherboard. If your computer has an older motherboard with a 20-pin main power socket, connect only the 20-pin main power connector.

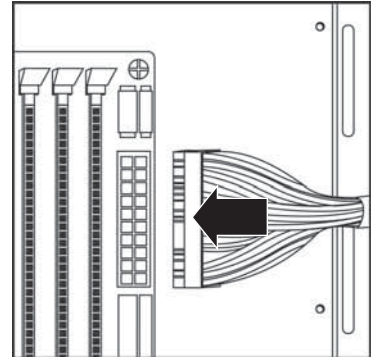

- b. Connect the 8-pin (4+4) or 4-pin +12 V power connector to your motherboard.

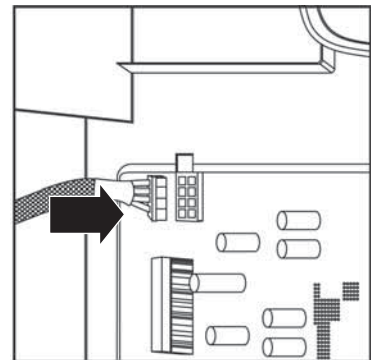

- c. Connect all of the following that apply to your computer:
 - i. The 4-pin peripheral connectors (4) to any computer components with a 4-pin connector, such as an IDE drive or a case fan.

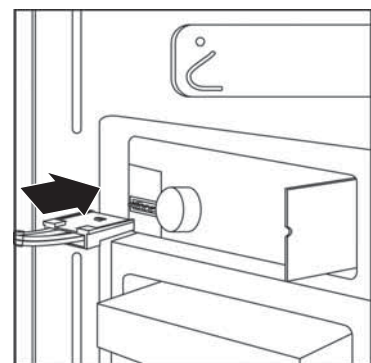

- ii. The floppy drive power connector to the floppy drive.

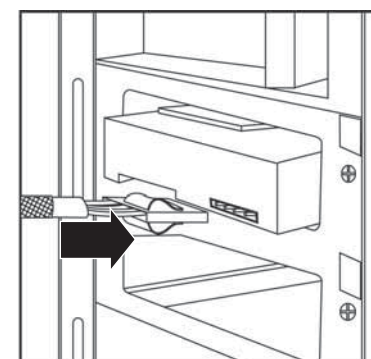

- iii. The Serial ATA connectors (4) to any computer components that have a Serial ATA connector, such as a CD/DVD/Blu-ray or hard drive.

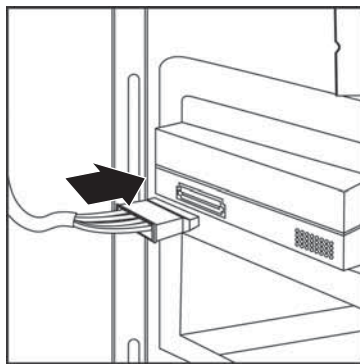

- iv. The 8-pin PCI-E or 6-pin PCI-E connector to a PCI-E graphics card.

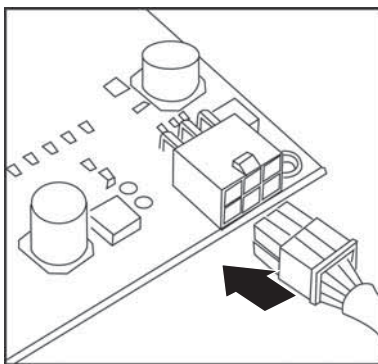

Caution: Make sure that all connectors are securely connected. Incorrect connections could prevent your computer from starting and could damage some components.

- 3 Close your computer case.
- 4 Connect the AC power cord to the power supply, then to a surge protector or wall outlet.
- 5 Turn on your computer by pressing the power button on the front of the case.

Note: For more information, refer to your computer's user guide.

Connector types

Connector	Illustration	Connect to
20+4-PIN Main Power		The motherboard
4-PIN+ 12V - (400 Watt PS only)		The motherboard (for CPU power)
-----OR-----		
8-PIN (4+4) + 12V - (520 Watt PS only)		The motherboard (for CPU power)
4-PIN peripheral - Total 3 connectors		Internal IDE drives
Serial ATA (SATA) - Total 4 connectors		Internal SATA drives
Floppy drive		3.25" floppy drive
6-PIN PCI-E (400 Watt PS only)		PCI Express card (such as a graphics card) that requires power
-----OR-----		
8-PIN PCI-E (520 Watt PS only)		PCI Express card (such as a graphics card) that requires power

Troubleshooting

If your new power supply is not working correctly, try the following:

- Make sure that the computer power cord is firmly plugged into the power cord connector on your computer.
- If you are using a surge protector, make sure that it is plugged in and turned on.
- Make sure that the wall outlet is supplying power. For example, plug a lamp into the outlet and turn it on.
- If you have the DX-400WPS, make sure that the red voltage switch (located on the back of the power supply) is set to the correct voltage setting. The setting for the United States is 115 V. The setting for Europe and other countries is 230 V.
- Make sure that the system board power supply cable is securely connected to the system board connector (24 pin or 20 pin).
- Make sure that all power supply cables to peripheral devices, such as hard drives, optical drives, and fans, are securely connected. Any loose power cable connections may cause the power supply to operate incorrectly.
- The power supply may be overloaded. Unplug any unnecessary components, such as extra drives, then try again.
- If the power supply is very hot, check the case fans and the power supply fan. Replace any faulty case fans, then try again.
- If you have the DX-400WPS, make sure the power switch (I/O) on the back of the power supply is set to ON (I).

Specifications

400 Watt Power Supply

Output Voltage	+12V1DC	+12V2DC	+5VDC	+3.3VDC	-12VDC	+5Vsb
Max Load	8.0 A	14.0 A	20.0 A	20.0 A	0.3 A	2.5 A
Min Load	1.0 A	1.0 A	0.3 A	0.5 A	0.0 A	0.1 A
Max Watt	300 W					
Peak Power	400 W					
Regulation	±5%	±5%	±5%	±5%	±10%	±5%
Ripple	120 mV	120 mV	50 mV	50 mV	120 mV	50 mV
Noise	120 mV	120 mV	50 mV	50 mV	120 mV	50 mV
Power Good Signal	100-500 mS					
Power Fail Signal	1 mS Min.					
Hold-up Time	16 mS Min.					
Dimensions	5.5 × 3.4 × 5.9 inches (W × H × L) 140 × 86 × 150 mm (W × H × L)					

520 Watt Power Supply

Output Voltage	+12V1DC	+12V2DC	+5VDC	+3.3VDC	-12VDC	+5Vsb
Max Load	18.0 A	16.0 A	18.0 A	20.0 A	0.3 A	2.0 A
Min Load	1.0 A	1.0 A	0.5 A	0.3 A	0.0 A	0.005 A
Max Watt	420 W					
Peak Power	520 W					
Regulation	±5%	±5%	±5%	±5%	±10%	±5%
Ripple	120 mV	120 mV	50 mV	50 mV	120 mV	50 mV
Noise	200 mV	200 mV	100 mV	100 mV	200 mV	100 mV
Power Good Signal	100-500 mS					
Power Fail Signal	1 mS Min.					
Hold-up Time	16 mS Min.					
Dimensions	5.5 × 3.4 × 5.9 inches (W × H × L) 140 × 86 × 150 mm (W × H × L)					

Legal notices

FCC warning

This equipment may generate or use radio frequency energy. Changes or modifications to this equipment may cause harmful interference unless the modifications are expressly approved in the instruction manual. The user could lose the authority to operate this equipment if an unauthorized change or modification is made.

Caution: Any change or modification to the equipment not expressly approved by the manufacturer or its authorized parties could void your authority to operate the equipment.

UL statement

Any information or documentation provided to you involving UL Mark services is provided on behalf of Underwriters Laboratories, Inc. Products that bear the UL Mark are identical to those that were evaluated by UL and found to be technically compliant with the UL's applicable requirements.

For further information regarding the use of UL marks, please visit the UL Website at www.ul.com.



One-year limited warranty - Dynex

Definitions:

Dynex Products ("Dynex") warrants to you, the original purchaser of this new Dynex-branded product ("Product"), that the Product shall be free of defects in the original manufacturer of the material or workmanship for a period of one (1) year from the date of your purchase of the Product ("Warranty Period"). For this warranty to apply, your Product must be purchased in the United States or Canada from a Best Buy or Future Shop authorized dealer of Dynex brand products only that are packaged with this warranty statement.

How long does the coverage last?

The Warranty Period lasts for 1 year (365 days) from the date you purchased the Product. Your purchase date is printed on the receipt you received with the Product.

What does this warranty cover?

During the Warranty Period, if the original manufacture of the material or workmanship of the Product is determined to be defective by an authorized Dynex repair center or store personnel, Dynex will (at its sole option): (1) repair the Product with new or rebuilt parts; or (2) replace the Product at no charge with new or rebuilt comparable products or parts. Products and parts replaced under this warranty become the property of Dynex and are not returned to you. If service of Products or parts are required after the Warranty Period expires, you must pay all labor and parts charges. This warranty lasts as long as you own your Dynex Product during the Warranty Period. Warranty coverage terminates if you sell or otherwise transfer the Product.

How to obtain warranty service?

If you purchased the Product at a Best Buy or Future Shop retail store location, please take your original receipt and the Product to any Best Buy or Future Shop store. Make sure that you place the Product in its original packaging or packaging that provides the same amount of protection as the original packaging. If you purchased the Product from a Best Buy or Future Shop online web site, mail your original receipt and the Product to the address listed on the web site. Make sure that you put the Product in its original packaging or packaging that provides the same amount of protection as the original packaging. To obtain warranty service, in the United States call 1-888-BESTBUY, Canada call 1-866-BESTBUY for Future Shop call 1-800-663-2275. Call agents may diagnose and correct the issue over the phone.

Where is the warranty valid?

This warranty is valid only in the United States and Canada at Best Buy or Future Shop branded retail stores or websites to the original purchaser of the product in the county where the original purchase was made.

What does the warranty not cover?

This warranty does not cover:

- Customer instruction/education
- Installation
- Set up adjustments
- Cosmetic damage
- Damage due to acts of God, such as power surges
- Accident(s)
- Misuse
- Abuse
- Negligence
- Commercial purposes/use, including but not limited to use in a place of business or in communal areas of a multiple dwelling condominium or apartment complex, or otherwise used in a place of other than a private home.
- Modification of any part of the Product, including the antenna
- Display panel damaged by static (non-moving) images applied for lengthy periods (burn-in).
- Damage due to incorrect operation or maintenance
- • Connection to an incorrect voltage or power supply
- • Attempted repair by any person not authorized by Dynex to service the Product

- Products sold "as is" or "with all faults"
- Consumables, including but not limited to batteries (i.e. AA, AAA, C etc.)
- Products where the factory applied serial number has been altered or removed
- Loss or Theft of this product or any part of the product
- Up to three (3) pixel failures (dots that are dark or incorrectly illuminated) grouped in an area smaller than one tenth (1/10) of the display size or up to five (5) pixel failures throughout the display. (Pixel based displays may contain a limited number of pixels that may not function normally.)
- Failures or Damage caused by any contact including but not limited to liquids, gels or pastes.

REPAIR REPLACEMENT AS PROVIDED UNDER THIS WARRANTY IS YOUR EXCLUSIVE REMEDY FOR BREACH OF WARRANTY. DYNEX SHALL NOT BE LIABLE FOR ANY INCIDENTAL OR CONSEQUENTIAL DAMAGES FOR THE BREACH OF ANY EXPRESS OR IMPLIED WARRANTY ON THIS PRODUCT, INCLUDING, BUT NOT LIMITED TO, LOST DATA, LOSS OF USE OF YOUR PRODUCT, LOST BUSINESS OR LOST PROFITS. DYNEX PRODUCTS MAKES NO OTHER EXPRESS WARRANTIES WITH RESPECT TO THE PRODUCT, ALL EXPRESS AND IMPLIED WARRANTIES FOR THE PRODUCT, INCLUDING, BUT NOT LIMITED TO, ANY IMPLIED WARRANTIES OF AND CONDITIONS OF MERCHANTABILITY AND FITNESS FOR A PARTICULAR PURPOSE, ARE LIMITED IN DURATION TO THE WARRANTY PERIOD SET FORTH ABOVE AND NO WARRANTIES, WHETHER EXPRESS OR IMPLIED, WILL APPLY AFTER THE WARRANTY PERIOD. SOME STATES, PROVINCES AND JURISDICTIONS DO NOT ALLOW LIMITATIONS ON HOW LONG AN IMPLIED WARRANTY LASTS, SO THE ABOVE LIMITATION MAY NOT APPLY TO YOU. THIS WARRANTY GIVES YOU SPECIFIC LEGAL RIGHTS, AND YOU MAY ALSO HAVE OTHER RIGHTS, WHICH VARY FROM STATE TO STATE OR PROVINCE TO PROVINCE.

Contact Dynex:

For customer service please call 1-800-305-2204

www.dynexproducts.com

Distributed by Best Buy Purchasing, LLC

7601 Penn Avenue South, Richfield, Minnesota, U.S.A. 55423-3645

© 2014 BBY Solutions, Inc.

All rights reserved. DYNEX is a trademark of BBY Solutions, Inc. Registered in some countries. All other products and brand names are trademarks of their respective owners.

DYNEX™

www.dynexproducts.com (800) 305-2204

Distributed by Best Buy Purchasing, LLC
7601 Penn Ave. South, Richfield, MN 55423 U.S.A.
© 2014 BBY Solutions, Inc. All rights reserved.

DYNEX is a trademark of BBY Solutions, Inc. Registered in some countries. All other products and brand names are trademarks of their respective owners.

V5 ENGLISH
13-0313

Free Manuals Download Website

<http://myh66.com>

<http://usermanuals.us>

<http://www.somanuals.com>

<http://www.4manuals.cc>

<http://www.manual-lib.com>

<http://www.404manual.com>

<http://www.luxmanual.com>

<http://aubethermostatmanual.com>

Golf course search by state

<http://golfingnear.com>

Email search by domain

<http://emailbydomain.com>

Auto manuals search

<http://auto.somanuals.com>

TV manuals search

<http://tv.somanuals.com>