



MODEL GL-C

INSTALLATION & OPERATION

Rev. 1.00A



CMA DISHMACHINES
12700 KNOTT AVENUE
GARDEN GROVE, CALIFORNIA 92841

800-854-6417

FAX 714-895-2141

www.cmadishmachines.com

TABLE OF CONTENTS

MODEL GL-C

1. RECEIVING	2
2. SPECIFICATIONS	3
3. INSTALLATION.....	4
3.1. ELECTRICAL.....	4
3.2. PLUMBING.....	4
4. GLC FLOW DIAGRAM.....	4
5. OPERATION.....	6
5.1. FILLING THE WASH TANK.....	6
5.2. OPERATING INSTRUCTIONS	6
3.2.1. <i>Proper Chemical Dosage</i>	6
5.3. CLEANING INSTRUCTIONS	7
3.3.1. <i>Daily Cleaning Instructions</i>	7
3.3.2. <i>Weekly Cleaning Instructions</i>	7
6. MAINTENANCE.....	8
6.1. TROUBLESHOOTING.....	8
7. ELECTRICAL DIAGRAM	10

1. Receiving

1. Remove the packing material from the top of the conveyor stack.
2. Remove all packing material and tape securing components within the machine. Check that both trays are positioned properly.
3. Check for the following component parts:
 - A. Check that the deflector screen is secure in the rinse drain.
 - B. Check the position of the GL-C curtain.
 - C. Check that the conveyor is level and the drive gear is engaged in the conveyor's outer rim grooves.
 - D. Check that overflow drain tube is in position in detergent tank.
 - E. Check that the detergent tank screen in the detergent tank is in position.
 - F. Check that the drain screen is in position.
4. Important: Read and follow up instructions completely.

2. Specifications

WATER CONSUMPTION		
HOT WATER INITIAL FILL	3 GAL.	11.35 L.
HOT WATER PER HOUR (max)	12 GAL.	45.42 L.
COLD WATER PER HOUR	168 GAL.	636 L.
OPERATING CAPACITY		
(2-1/2") GLASSES PER HOUR	1000	-
WATER REQUIREMENTS		
COLD WATER INLET	1/2"	-
HOT WATER INLET	1/2"	-
DRAIN CONNECTION	1-1/2"	-
TEMPERATURES		
INLET COLD WATER	75 °F	24°C
INLET HOT WATER (recommended)	140°F	60°C
FRAME DIMENSIONS		
DEPTH	25-1/8"	63.8CM
WIDTH	25-1/4"	64CM
HEIGHT	39"-40"	99.1-101.6CM
MAX CLEARANCE FOR GLASSES	10"	25.4CM
ELECTRICAL		
	240 VAC	
	15 AMPS	
TANK HEATER (Not Booster Heater)	3KW	
WASH PUMP MOTOR	.1HP	
SHIPPING WEIGHT		
GL-C (Approximate)	156#	71 kg

3. Installation

3.1. *Electrical**

A 15 Amp, 240 Volt, 60 Hz dedicated circuit should be used to supply electrical power to the GL-C machine (see specification sheet page 2). The power connection with the leads L-1, L-2 and Ground must be such that there is sufficient length of flexible conduit to permit the machine to be moved for cleaning. This machine operates from 208 to 240 Volts.

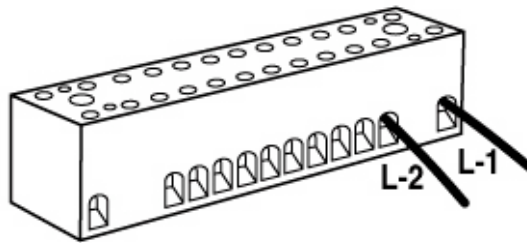

3.2. *Plumbing**

Hot Water Connection

1. Connect a minimum 1/2" water line to the hot water solenoid valve. Supply temperature must be minimum 140°F/60°C, with flow pressure between 25-95 PSI.
2. Hot water consumption is approximately 12 U.S. gph.

Cold Water Connection

1. Connect a minimum 1/2" water line to the cold water solenoid valve. Flow pressure must be between 25-95 PSI.
2. Open ball valve located between hot and cold solenoid valves until temperature reaches 75°F for areas with very cold rinse water to heat the rinse water which will prevent glasses from cracking.
3. Cold water consumption is approximately 2.8 U.S. gpm.

Drain Connection

1. Connect a 1-1/2" drain line where indicated.
2. PVC pipe is generally recommended, as copper is prone to attack by the sanitizing chemicals.

***Electrical and plumbing connections must be made by a qualified person who will comply with all available Federal, State, and Local Health, Electrical, Plumbing and Safety codes.**

4. GLC Flow Diagram

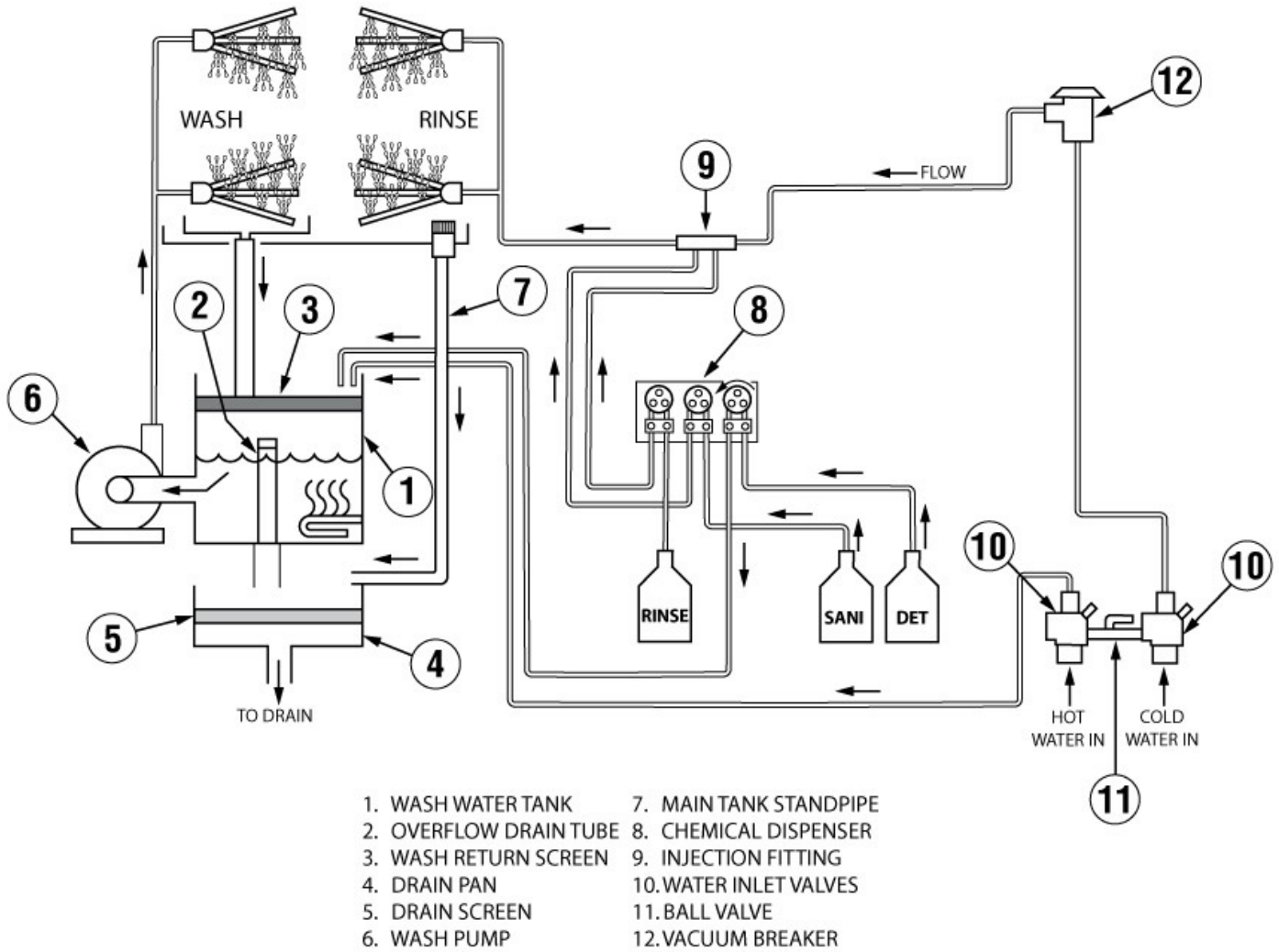

5. Operation

5.1. Filling the Wash Tank

- Ensure that the overflow drain tube is in place in the detergent tank.
- Flip power on-off/flush switch to the "ON" position. The water will fill until the proper level is reached then turn the heating element "ON".
- The water temperature is controlled by a heater and a thermostat. The thermostat should be set for minimum 140°F/60°C.

5.2. Operating Instructions

- Open the door; flip power on-off/flush switch to the "ON" position. Wash tank will automatically fill.
- Ensure there is product in the detergent, sanitizer and rinse agent containers.
- Detergent is fed from the supply container into the detergent tank in controlled amounts by the detergent pump. Use detergent at strength recommended by your chemical supplier.
- Load glasses on the conveyor. Start machine with GL-C rocker switch located on front right side of unit. Machine now will stop and start with conveyor shut-off rod.

3.2.1. Proper Chemical Dosage

The amount of chemical delivered, whether it is detergent, sanitizer or rinse aid, can be obtained by counting the revolutions of the injector rotors.

- For detergent, contact your chemical supplier for proper type and detergent concentration.
Note: *Detergent pump only operates when hot water tank is filling.*
- For sanitizer, one revolution in 5 seconds equals approximately 12.5ppm Iodine or 50ppm chlorine.
- For rinse agent, one revolution in 8 seconds is recommended.

To Adjust Detergent Injector:

- When a new detergent container is installed, push the prime button in and hold until the detergent feed tube is full.
- Install the overflow drain tube and switch power on-off/flush switch to the "ON" position. The detergent feeder will now feed detergent into the detergent tank with water fill.
- To increase detergent volume, turn the detergent adjustment screw clockwise.
- To decrease the detergent volume, turn the detergent adjustment screw counter-clockwise.

To Adjust Sanitizer Injector:

- When a new sanitizer container is installed, push the prime button in and hold until sanitizer feed tube is full.
- Start the washer with rocker switch located on the front of the machine. Take a sample from the final rinse spray tube to check sanitizer level.
- To increase the volume of sanitizer, turn the adjustment screw clockwise.
- To decrease the volume of sanitizer, turn the adjustment screw counter-clockwise.

To turn rinse agent injector "OFF" in this case, turn the adjustment screw counter-clockwise until the pump stops turning.

Note: *If a sodium Hypochlorite (Chlorine) based sanitizer at a minimum concentration of 50ppm in the final rinse is used, use chlorine test papers to verify and monitor the 50ppm chlorine level*

To Adjust Rinse Agent Injector:

- When a new rinse agent container is installed, push the prime button in and hold until the rinse injector feed tube is full.
- Start the washer. Take a sample from the final rinse spray tubes.
- To increase the volume of rinse agent, turn the adjustment screw clockwise.
- To decrease the volume of rinse agent, turn the adjustment screw counter-clockwise.

Note: To meet the requirements of N.S.F. standards, Iodophor in a concentration of 12.5ppm or chlorine at 50ppm must be used in the final rinse.

5.3. Cleaning Instructions

3.3.1. Daily Cleaning Instructions

Remove optional GL-C drain tray & waste collection, from the front of your glasswasher and clean.

Turn glasswasher off by flipping the power on-off/flush switch to the "OFF" position.

Remove right and left trays and GL-C curtain. Wash them with hot soapy water, rinse thoroughly, and then dry.

Remove the conveyor as follows: Remove conveyor hub, flip conveyor shut-off rod to the side, lift conveyor from the center and pull out.

Remove lower wash and rinse arms. Clean wash and rinse areas with hot soapy water. Rinse thoroughly, and then dry.

Note: Do not twist spray arms, pull straight out or they will break.

Replace lower wash and rinse arms (they only fit one way). Replace conveyor as follows: With back end of conveyor raised, mesh drive gear with side of conveyor, pull conveyor towards you until center of conveyor drops onto pivot. Replace conveyor hub in center of conveyor, flip shut-off bar back to normal position. Replace left tray ensuring shut-off arm rests within the retainer, then replace right tray. Replace curtain.

Remove and clean upper and lower wash tank screens.

Remove overflow drain tube from the detergent tank, wash down the interior of the detergent tank. Replace overflow drain tube and upper and lower wash tank screens.

Note: Do not leave water in tank overnight!!!

Replace optional GL-C drain tray & waste collection making sure hose is connected.

Ensure there is product in the detergent, sanitizer and rinse agent containers. Close the door.

3.3.2. Weekly Cleaning Instructions

Remove upper and lower wash and rinse arms from the manifold and clean spray tubes with Cleaning Drill p/n 00899.01, Cleaning Brush p/n 00899.02 provided.

Remove detergent, sanitizer, and rinse agent feed lines from containers and place them in a container of hot water. Hold prime buttons in until the feed lines have been thoroughly flushed. Replace the feed lines to their proper container and prime product through lines.

6. Maintenance

6.1. Troubleshooting

PROBLEM	LIKELY CAUSE	SOLUTION
Conveyor doesn't turn	Power off at circuit breaker	Reset circuit breaker
	Drive motor burn out	Replace drive motor
	Obstruction in wash or rinse	Remove obstruction
	Micro switch on switch support bracket faulty or not making contact	Replace or adjust
	Conveyor not in position	Position properly
Excessive overspray from hood section	Splash curtain not in position	Install or adjust
	Washer running without any glasses on conveyor	Keep conveyor loaded with glasses
	Spray tubes fallen off hub	Ensure spray tube is pushed firmly on to hub connection
	Spray tubes plugged	Clear and clean with reamer, scraper, and brush
Lack of pressure in wash spray tubes	No water in detergent tank	Ensure water supply is on Ensure detergent tank stand pipe is in position Ensure the tank fill switch is in On-Fill position and that tank fills with water Ensure the float switch is activated by the float cam Ensure the tank fill solenoid is operational
	Obstruction in wash arm	Clear obstruction
	Pump not operating	Check power supply to machine Check pump capacitor Replace pump if required
	Pump operating but no pressure	Check condition of impeller and stub shaft Replace if needed
Lack of pressure in rinse spray tube	Rinse spray tubes dirty	Clean thoroughly with reamer, scraper, and brush provided
	Shut-off valve on supply line closed	Open valve
	Low water pressure	Minimum 25PSI flow pressure required

Maintenance

PROBLEM	LIKELY CAUSE	SOLUTION
Lack of pressure in rinse spray tube	Rinse solenoid valve will not operate	Check coil Check and install rebuild kit Replace if necessary
	Rinse solenoid valve strainer plugged	Remove screen and clean
Water continues to flow to detergent tank or spray tubes with machine off	Solenoid valve not sealing	Clean seat Install diaphragm kit Replace valve
Water temperature low in detergent tank	Thermostat setting low	Adjust thermostat
	Thermostat defective	Replace
	Defective float switch	Replace
	Heater burnt out	Check and replace Ensure water level is above element
	Incoming water temp. low	Hot water supply min.140°F/60°C
Water on floor around machine	Pump seal leaking	Replace
	Rinse drain in wash area plugged	Clear obstruction, clean machine
	Wash return screen in detergent tank plugged	Clean
	Drain screen under detergent tank plugged	Clean
	Main drain plugged	Clean
	Detergent tank covers are not positioned properly causing condensation	Position all top covers to completely cover top of tank
	Fill chute has lime build-up	De-scale detergent tank
Chemical containers filling with water	Dirty rinse tubes	Clean
	Worn flow washer in solenoid valve	Replace
Chemicals not feeding	No product in containers	Refill containers
	Product gelling or crystallizing in chemical line	Flush all lines with hot water and use fresh supply of chemical
	Chemical supply strainer plugged	Clean with hot water
	Speed adjustment set too low	Increase by turning clockwise while machine is running/filling
	No power to pump	Check LED signal
	Pump motor defective	Replace pump motor

7. Electrical Diagram

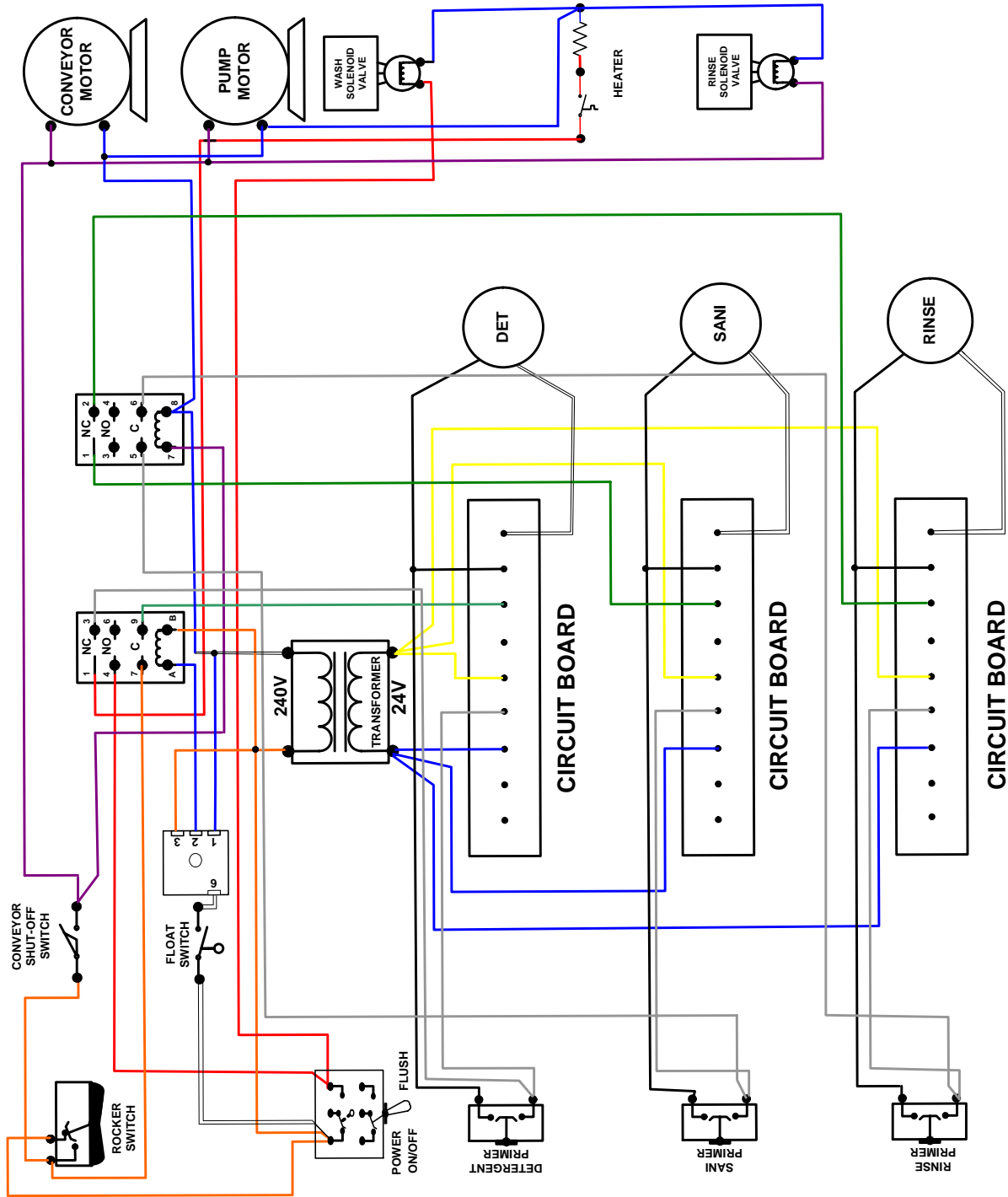

Free Manuals Download Website

<http://myh66.com>

<http://usermanuals.us>

<http://www.somanuals.com>

<http://www.4manuals.cc>

<http://www.manual-lib.com>

<http://www.404manual.com>

<http://www.luxmanual.com>

<http://aubethermostatmanual.com>

Golf course search by state

<http://golfingnear.com>

Email search by domain

<http://emailbydomain.com>

Auto manuals search

<http://auto.somanuals.com>

TV manuals search

<http://tv.somanuals.com>