

## CD-303

### FM/AM CD PLAYER OPERATION AND INSTALLATION MANUAL

4260 Charter Street  
Vernon, CA, 90058-2596, U.S.A.

TEL: 800-227-8879 or 213-582-2832  
FAX: 213-582-4328  
TLX: 910-240-6376

A DIVISION OF CONCEPT ENTERPRISES, INC.  
COPYRIGHT © 1991  
BY CONCEPT ENTERPRISES, INC.  
ALL RIGHTS RESERVED

## CONGRATULATIONS...

on purchasing the Coustic CD-303 high power FM/AM CD player. Your choice expresses a sophisticated appreciation for fine music reproduction. Whether you are adding the Coustic CD-303 to an existing system or installing a completely new system, you are certain to notice immediate performance benefits.

Your CD-303 is a removable high-power car radio and CD player. It features a high-resolution three beam laser pick-up, a four times oversampling digital filter, and a fully-calibrated 16 bit digital-to-analog converter to give you crystal clear compact disc sound reproduction. The radio includes advanced design elements, like a PLL (Phase Lock Loop) quartz tuner with precise FM Optimizer V circuitry, 18 Preset Station Memories with 12 Automatic Station Memories, Preset Scan, Bi-Level Fader Control, Active Bass/Treble Tone controls and Auxiliary Input. With all of these features at your fingertips, you are assured of receiving the best possible performance from your car audio system now and in the years to come.

Coustic does not just manufacture full-featured FM/AM CD players. We also build advanced radio/cassette units, high performance power amplifiers, unique electronic crossovers, dynamic hi-fi component speakers and graphic equalizers — everything you need to create the ultimate car audio system.

Coustic... a Sound Investment!

No part of this publication may be reproduced, stored in a retrieval system, or transmitted in any form or by any means, electronic, mechanical, photocopying, recording, or otherwise, without the prior written permission of CONCEPT ENTERPRISES, Inc.

Model No.: \_\_\_\_\_ Dealer Stamp: \_\_\_\_\_

Serial No.: \_\_\_\_\_ Date of Purchase: \_\_\_\_\_

## TABLE OF CONTENTS

Section	Page
<b>FEATURES OF COUSTIC CD-303 .....</b>	<b>4</b>
<b>CONTROLS AND INDICATORS .....</b>	<b>6</b>
Controls .....	6
Indicators .....	9
<b>OPERATION OF CD PLAYER AND RADIO .....</b>	<b>10</b>
CD Player Operation .....	10
Disc Play .....	10
Intro Scan .....	10
Track Skip .....	10
Audible Music Search .....	11
Shuffle Play .....	11
Repeat Track .....	11
Programmable Memory .....	11
Radio Operation .....	12
Initial Settings .....	12
Manual Tuning .....	12
Automatic Seek Tuning .....	12
Automatic Scan Tuning .....	12
Memory .....	12
Automatic Station Memory .....	12
Last Station Memory .....	12
Preset Scan/Automatic Station Memory Scan .....	12
Auxiliary Input .....	13
<b>CARE AND MAINTENANCE .....</b>	<b>13</b>
Compact Disc Care and Maintenance .....	13
Fuse Replacement .....	13
<b>CD-303 INSTALLATION .....</b>	<b>13</b>
Precautions .....	13
Required Tools .....	13
Mechanical Installation Procedures .....	14
Electrical Installation Procedures .....	16
Electrical Wiring Diagram .....	17
Wiring Descriptions .....	16
Final System Check .....	18
<b>TROUBLE SHOOTING GUIDE .....</b>	<b>18</b>
<b>SPECIFICATIONS .....</b>	<b>20</b>

## CD-303 HIGHLIGHTS

Your CD-303 is equipped with the latest technological advancements for the ultimate CD sound and radio reception available for your car's personal environment. These newest features include:

- High-Resolution Three Beam Laser Pick-up
- Four Times Oversampling Digital Filter
- Fully Calibrated 16 Bit Digital to Analog (D/A) Converter
- Anti-Skip Floating Suspension CD Mechanism
- Three-Inch Disc Compatibility
- Soft Load, Auto Play and Auto Disc Repeat
- 16 Track Programmable Memory
- Shuffle Play
- Intro Scan
- Forward/Backward Track Advance
- Forward/Backward Music Search
- Repeat Track
- Instant Replay
- PLL Quartz Synthesizer Tuning
- Advanced FM Optimizer V Circuitry
- Built-In FM Noise Canceller
- 18 Preset Station Memories (12 FM, 6 AM)
- 12 Automatic Station Memories (6 FM, 6 AM)
- Preset Scan
- Automatic Seek/Scan & Manual Tuning
- Auxiliary Input
- Local/Distant & Mono/Stereo Switching
- Loudness Control
- Active Bass & Treble Tone Controls
- Bi-Level Fader Control
- Variable Two-Color Control Panel Illumination
- Removable Chassis with Lithium Backup Battery
- Gold Plated Front/Rear Pre-Amp Outputs
- Built-in High Power Amplifier

## FEATURES

### HIGH-RESOLUTION THREE BEAM LASER PICK-UP

The advanced high-resolution three beam laser pick-up head provides accurate retrieval of encoded CD information, even under severe road conditions or playback of scratched or dirty discs.

### FOUR TIMES OVERSAMPLING DIGITAL FILTER

Typically found in home CD players, the four times oversampling digital filter removes high frequency "quantization noise" inherent in all digital recording. An analog filter with a gentle slope then suppresses the remaining "very" high frequency noise. This design guarantees perfect phase linearity and provides dramatic clarity in the "soundstage" reproduction.

### FULLY CALIBRATED 16 BIT DIGITAL TO ANALOG CONVERTER

Also commonly used in home CD players, the sophisticated digital to analog (D/A) converter is precisely calibrated to accurately convert digital information to analog signal providing dedicated acoustic reproduction. The converter's accuracy, or linearity, eliminates harmonic distortion and faithfully reproduces the critical "ambience" of the original recording.

### ANTI-SKIP FLOATING SUSPENSION CD MECHANISM

Your CD-303 incorporates the latest technology in CD mechanisms specially designed for automobile applications. A rugged floating suspension system allows the CD player to maintain accurate tracking without skipping even on rough roads, and at the same time protects the CD mechanism and your CD's from damage.

### THREE-INCH DISC COMPATIBILITY

Your CD-303 plays not only the standard 5" CD's, but also 3" singles without the use of an adaptor.

### SOFT LOAD, AUTO PLAY AND AUTO DISC REPEAT

The built-in Soft Load mechanism smoothly loads any compact disc into the player compartment without the possibility of damaging the disc surface. The Auto Play feature will play the first track automatically. The Auto Disc Repeat function gives you the option of playing the entire disc over and over again.

### 16 TRACK PROGRAMMABLE MEMORY

This feature allows you to choose a number of tracks — as many as 16 — from any of your favorite CD's for playback without interruption from the other tracks on the disc.

### SHUFFLE PLAY

Shuffle Play (also called Random Play) shuffles the playing order of tracks on the CD's you listen to most. You'll find this feature reduces the monotony of listening to a disc in the same order each time.

### INTRO SCAN

This feature allows you to scan and play the first 10 seconds of each track on a compact disc. You can use Intro Scan to briefly audition a track before deciding whether to play it or skip it.

### FORWARD/BACKWARD TRACK ADVANCE

This convenient feature allows you to skip tracks or return to the beginning of the loaded CD.

### FORWARD/BACKWARD MUSIC SEARCH

This feature allows you to search forward or backward at 20 times normal playback speed to quickly find a particular section of a CD track.

### REPEAT TRACK

Repeat Track lets you listen to a favorite CD track over and over again.

### INSTANT REPLAY

Instant Replay lets you quickly and automatically return to the beginning of a disc for instant replay. It is an efficient alternative to Backward Track Advance, which steps back through every track to find the beginning of a disc.

### PLL QUARTZ SYNTHESIZER TUNING SYSTEM

Your CD-303 is equipped with a sophisticated phase-locked loop (PLL) quartz synthesizer tuner and a microprocessor to provide extremely accurate tuning.

### ADVANCED FM OPTIMIZER V CIRCUITRY

The CD-303 circuitry contains the latest in technological developments, including: An improved (dual MOS-FET) Two-Stage Input Signal Control Circuit; a redesigned quasi Four-Gang, High-Gain (Low-Noise) Tuned Front End; Advanced FM Optimizer V circuitry with Keyed Automatic Gain Control (AGC); and a new IF circuit with PIN Diode Control.

The Two-Stage Input Signal Control Circuit uses a PIN Diode at the first stage to preserve desired signal path and to restrict strong signals from overloading the front end. At the second stage, a new IF Circuit lowers the front end gain to further reduce interference.

Following that, a dual RF balanced mixer provides increased spurious rejection for enhanced FM selectivity. The end result is total elimination of front end overload, more dynamic range of signal processing, and further enhancement of Stereo Noise Control (SNC) operation. The new Advanced FM Optimizer V Circuitry continuously monitors FM signal strength and adjusts stereo separation, audio bandwidth and audio level to guarantee the best wide band signal-to-noise ratio. With this circuit, off-channel overloading and the "picket-fencing" effects of multi-path reception are virtually eliminated.

## FEATURES

### BUILT-IN FM NOISE CANCELLER

This circuit promotes interference-free FM reception, suppressing outside noise generated by motorcycles, sparks, or pulses.

### 18 MEMORY PRESET STATIONS

Your CD-303 features 18 Selectable Preset Station Memories (12 FM and 6 AM) with Last Station Memory. This function lets you quickly and easily access up to 18 of your favorite radio stations.

### AUTOMATIC STATION MEMORY

Automatic Station Memory will automatically let you store the six strongest AM and six strongest FM stations without affecting the standard preset memories. This feature is useful when you are traveling away from home and are unfamiliar with the stations in the area.

Preset and Automatic stations continue to be stored in memory even when the unit is removed from your vehicle via the built-in lithium back-up battery.

### PRESET SCAN

After you have preset your 18 favorite stations into the CD-303's Automatic Station Memory, you can quickly and easily access them by activating the Preset Scan function.

### AUTOMATIC SEEK/SCAN AND MANUAL TUNING

You can "tune-in" radio stations two ways, either with Automatic Seek/Scan, or by manually scanning the radio dial with Manual Tuning. Automatic Seek Tuning will search a frequency bandwidth and stop when a radio station is detected. Automatic Scan Tuning will scan an entire frequency bandwidth indefinitely, locking in for five seconds to each radio station before moving on.

### LOCAL/DISTANT AND MONO/STEREO SWITCHING

When the broadcast signal is too weak to provide high fidelity and noise-free music reproduction, you can switch the tuner either to Distant mode or to Mono reception, to improve sound quality.

### AUXILIARY INPUT

This feature allows the CD-303 to receive audio signals from an external source, such as a CD changer or cassette player. You can control the volume, bass, treble, and fader settings of the external source through the CD-303's front panel.

### LOUDNESS CONTROL

Your CD-303 has a built-in Loudness Control (Fletcher-Munson type) to automatically compensate for low volume loss of audible bass and treble frequencies. You can easily activate this special circuit by pressing the Loudness Control button.

### ACTIVE BASS AND TREBLE TONE CONTROLS

Special tone control circuits which utilize an operational amplifier based on analog computer technology provide a buffer, an active tone equalizer, a line driver and an audio amplifier. This special circuit produces extra amplifier headroom for lower noise and far wider dynamic range than was possible with previous designs.

### BI-LEVEL FADER CONTROL (Speakers and Pre-Amp)

A Bi-Level Fader Control allows you to adjust the relative level of front and rear pre-amp outputs, as well as the level of the front and rear speaker outputs simultaneously.

### VARIABLE TWO-COLOR CONTROL PANEL ILLUMINATION

Your CD-303 has a Switchable Two-Color (Amber or Green) Control Panel Illumination to match your car's dashboard illumination standard.

### REMOVABLE CHASSIS WITH LITHIUM BACK-UP BATTERY

You can easily slide the CD-303 out of its metal case while still retaining memory presets via the built-in Lithium Back-Up Battery.

### GOLD-PLATED FRONT/REAR PRE-AMP OUTPUT CONNECTORS

Your CD-303 has built-in gold-plated front and rear pre-amp output connectors for easy and reliable connection to external power amplifiers. Although they are more expensive, gold-plated connectors are non-corrosive, and remain conductive over long periods of time. Gold-plated connectors also have a lower contact resistance, which ensures extended frequency response, lower distortion, improved dynamic range, and better signal-to-noise performance.

### BUILT-IN HIGH POWER AMPLIFIER

The CD-303's built-in high power amplifier provides ample power for front and rear speaker components in your audio system. Maximum output is 4 X 15 watts.

## CONTROLS AND INDICATORS

This section will help you become familiar with controls and display indicators on the front panel of your COUSTIC CD-303 HIGH POWER FM/AM/MPX COMPACT DISC PLAYER shown in Figure 1.

Take a few moments to read the information presented in this section. It will help to facilitate your understanding of the powerful control options available at your fingertips. As you read about each control, we suggest you try experimenting with the control setting at the same time to briefly learn the effect of its range of adjustment. This exercise will help you quickly master your CD-303 so that you can begin enjoying all of its features right away. For more detailed operating instructions about each feature, refer to the OPERATIONS section.

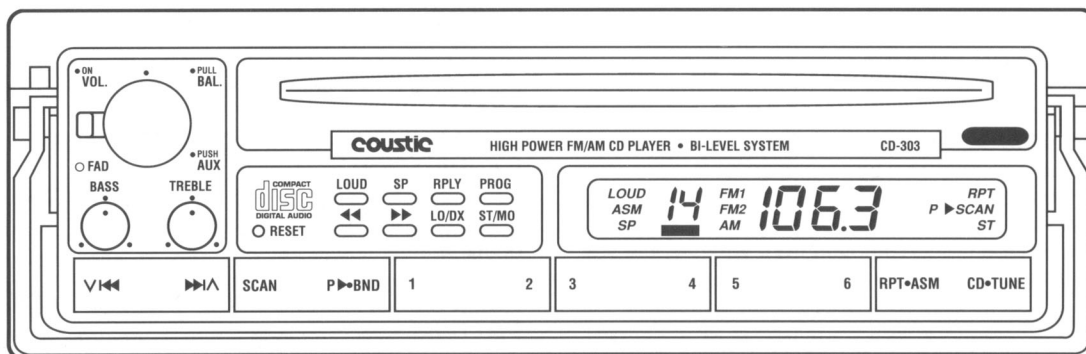
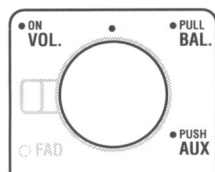

Figure 1. CD-303 Front Panel

### POWER ON-OFF, VOLUME CONTROL, BALANCE CONTROL AND AUXILIARY INPUT CONTROL

This single control allows you to access and set several functions:



- (Power) **ON** Turn on unit by rotating the knob clockwise (CW).
- (Power Off) Turn off unit by rotating the knob counterclockwise (CCW).
- VOL(ume)** Increase volume by rotating the knob CW. Decrease volume with continued CCW rotation of knob.
- BAL(ance)** Gently PULL out knob and rotate it CW to increase right speaker volume or CCW to increase left speaker volume. When you achieve a desired balance, push the knob in to retain the setting.
- AUX (input)** PUSH the knob once to switch the unit to Auxiliary Input Mode.

### FADER CONTROL

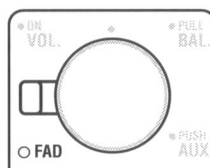

Located behind the VOLUME Control, the **FAD(er)** Control allows you to set the volume levels between front and rear speakers as well as line level outputs. Clockwise rotation of this control will increase volume of front speaker outputs as well as the front pre-amp outputs. Counter clockwise rotation will increase volume of rear speaker outputs as well as the rear pre-amp outputs.

### BASS CONTROL



Located below the VOLUME Control, the alternate-action **BASS** Control allows you to alter the bass (low) frequencies of the reproduced sound. First, push the knob in, then rotate it clockwise to increase bass or counterclockwise to decrease bass. When you are satisfied with the level of low frequency response, simply push the knob in again to retain the setting.

### TREBLE CONTROL



Also located below the VOLUME Control, the alternate-action **TREBLE** Control allows you to alter the treble (high) frequencies of the reproduced sound. First push the knob in, then rotate it clockwise to increase treble or counterclockwise to decrease treble. When you are satisfied with the level of high frequency response, simply push the knob in again to retain the setting.

## CONTROLS AND INDICATORS

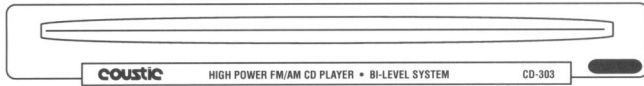

### COMPACT DISC LOADING SLOT

To play a CD, load the disc into the CD loading slot.

### CD EJECT BUTTON



To remove a CD from the player, press the CD eject button located to the right of the CD Loading Slot.

### RESET BUTTON



Your CD-303 uses an advanced micro-processor to monitor and to control a number of electronic functions. Sometimes static electricity or noise spikes on your car's electrical system can jumble the instruction set, causing an improper sequence of events to occur. To clear this problem and restore normal operation, press the **RESET** Button, located directly to the right of the TREBLE Control. Additional steps may be required. For these, refer to the TROUBLE SHOOTING GUIDE located at the end of this manual.

### CD PLAYER/TUNER SELECTOR



Located at the lower right corner, the **CD•TUNE** selector switches power between the CD player and the tuner. The LCD Readout Panel (directly above **CD•TUNE**) confirms your mode selection by displaying associated indicators, including track number (CD Mode) or station frequency (Radio Mode). When your CD-303 is in CD play mode, press the **CD•TUNE** button once to stop disc play and switch the unit to Radio Mode. When you want to return to CD Mode, press the **CD•TUNE** button again, and the unit will start playing from the beginning of the last track played.

### AUTO UP/DOWN SEEK TUNING CONTROL (Radio Mode) FORWARD/BACKWARD SKIP CONTROL (CD Mode)



Located below the BASS and TREBLE controls, this button allows you to access two sets of search functions:

In **Radio Mode**, the control functions as an Auto Up/Down Seek Tuning Control to let you automatically search for the nearest available station. Press the Up Seek button (**>>>^**) or the Down Seek button (**V<<<**) once to allow the tuner to search and stop the instant a station signal is received. Press the seek button again to search for the next station.

In **CD mode**, the control functions as a Forward/Backward Skip Button to let you access particular tracks on a CD. Press the Forward Skip button (**>>>^**) to advance to the beginning of the next track or the Backward Skip button (**V<<<**) to return to the beginning of the track being played.

### MANUAL UP/DOWN TUNING CONTROL (Radio Mode) FORWARD/BACKWARD MUSIC SEARCH CONTROL (CD Mode)



Located to the right of the TREBLE Control, this button allows you to access two additional sets of functions for either manual tuning or CD Music Search.

In **Radio Mode**, this control functions as a Manual Up/Down Tuning Control. Press the Up Tuning button (**>>>**) or Down Tuning button (**<<<**) once to select a higher or lower AM or FM frequency. Pressing and holding either button (**<<<**)/(**>>>**) will cause the tuner to access frequencies in either direction at a higher speed.

In **CD Mode**, this control functions as a Forward/Backward Music Search Control. Pressing and holding either button (**<<<**)/(**>>>**) will cause the player to advance forward or backward quickly through a track while you hear the music played at a faster speed.

### SCAN/PRESET SCAN CONTROL (Radio Mode) INTRO SCAN (CD Mode)



Located to the right of the Auto Up/Down Seek Tuning Control, this control allows you to audition station presets in Radio Mode or CD tracks in CD Mode.

In **Radio Mode**, this control functions as either a SCAN or Preset SCAN Control. Press the **SCAN** button once to activate a scan function that will allow you to briefly hear each station starting with the currently tuned station. Press and hold the **SCAN** button for at least two seconds to automatically scan and hear your preset stations stored in the CD-303 memory bank (12 stations for FM and 6 for AM). When you reach a desired station, press the **SCAN** button again to deactivate this function.

In **CD Mode**, this control functions as a CD track SCAN. Press the **SCAN** button to listen to the first 10 seconds of each track.

## CONTROLS AND INDICATORS

### BAND SELECTOR (Radio Mode) PROGRAM PLAY CONTROL (CD Mode)



Located to the right of the SCAN Control, this control lets you either select a frequency band in Radio Mode or start playback of a CD track in CD Mode.

In **Radio Mode**, this control functions as a radio Band (BND) Selector. Press the **P▶BND** button to select a desired frequency band (FM1, FM2 or AM). Your selection will appear on the LCD Readout Panel next to the radio frequency numbers.

In **CD Mode**, this control functions as a CD Program Play Control. Press the **P▶BND** button to start playback of pre-programmed CD tracks.

### PRESET STATION CONTROL



Located to the right of the BND Selector are 6 buttons (labelled 1 through 6) which are used for storing and recalling station presets. When you want to recall a station frequency from memory, just select a band (FM1, FM2, or AM) by pressing **BND**, and then press any Preset Station button 1 through 6. The tuner will immediately receive the frequency stored in the selected memory location.

### FM LOCAL/DISTANT SELECTOR



Located to the right of the Manual Up/Down Tuning Control, the FM Local/Distant Selector control lets you match your CD-303 tuner to desired FM signal strengths. To receive signals from distant FM stations, press the **LO/DX** (Local Distant) button until the **DX** indicator appears on the LCD Readout Panel. To receive only strong local FM stations, press the **LO/DX** button again until the **DX** disappears from the LCD Readout Panel.

### FM STEREO/MONO SELECTOR



Located to the right of the LO/DX Selector, the FM Stereo/Mono Selector allows you to select either stereo or mono reproduction of an FM signal. Press the **ST/MO** (Stereo Mono) button and observe the **ST** indicator appearing on the LCD Readout Panel. The stereo signal indicator **ST** will light up when a stereo broadcast is received. When the receiving signal is too weak or too noisy, press the **ST/MO** button to select mono reception. Both **ST** and **ST** indicators will disappear from the LCD Readout Panel, indicating that the tuner is in mono reception.

### LOUDNESS CONTROL



Located directly above the Manual Up/Down Tuning Control, the LOUD(ness) Control allows you to boost the high and low frequencies in either CD or Radio Mode. Press the **LOUD** button to activate a Loudness Control circuit and observe that a **LOUD** indicator appears on the LCD Readout Panel. Use this feature when you want to compensate for acoustic losses inside the car or when listening at low volume levels. When you press **LOUD** again, the circuit is deactivated and the **LOUD** indicator disappears.

### SHUFFLE PLAY CONTROL



Located to the right of the LOUD button, this control allows you to select random playback of CD tracks. Press the **SP** (Shuffle Play) button once to start continuous random playback of all tracks, and observe that an **SP** indicator appears on the LCD Readout Panel. To deactivate this function, press **SP** again and observe that the **SP** indicator disappears.

### INSTANT REPLAY CONTROL



Located to the right of the SP button, the RPLY (Instant Replay) Control allows you to return to the beginning of a CD for instant playback. Press the **RPLY** button to activate this function.

### PROGRAM BUTTON



Located to the right of the RPLY button, the PROG(ram) Control allows you to program your favorite CD tracks into memory. Refer to CD PLAYER OPERATION section for more details.

### AUTOMATIC STATION MEMORY (Radio Mode) REPEAT TRACK CONTROL (CD Mode)



Located to the right of Preset Station button 6, this control allows you to either change the station memory banks in Radio Mode or repeat a CD track in CD Mode.

In **Radio Mode**, this control functions as an Automatic Station Memory (ASM) Control. Press the **ASM** button once to access the bank of 12 memories (6 FM & 6 AM) stored by the Automatic Station Function or press and hold **ASM** for at least two seconds to activate the AUTOMATIC STATION MEMORY function. Refer to RADIO OPERATION for more details.

In **CD Mode**, this control functions as a Repeat Track (RPT) Control. Press the **RPT** button anytime you want to repeat the track currently being played.



## CONTROLS AND INDICATORS

### LCD READOUT PANEL

Located below the CD Loading Slot, the LCD Readout Panel provides you with visual feedback for each selected function. The following sections provide details on each indicator.

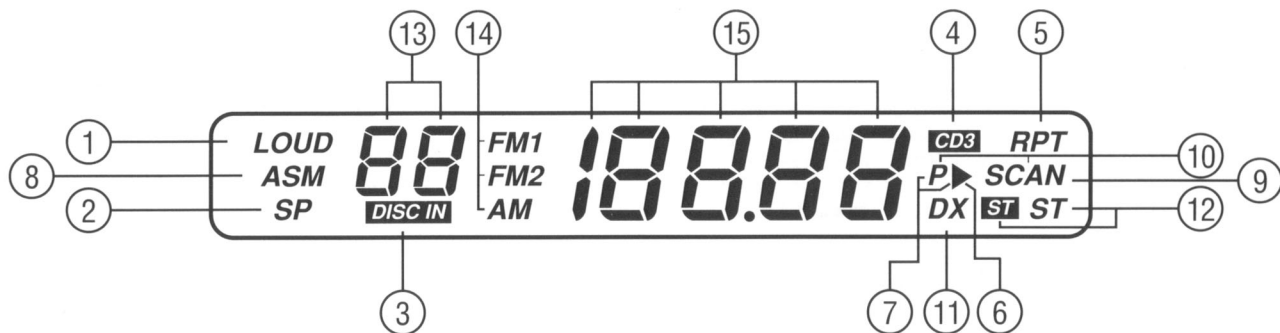

#### 1. LOUDNESS CONTROL INDICATOR

The **LOUD** indicator appears on the LCD Panel whenever you select the Loudness Control circuit (**LOUD** button).

#### 2. SHUFFLE PLAY INDICATOR

The **SP** indicator appears whenever you select the Shuffle Play feature (**SP** button).

#### 3. COMPACT DISC IN INDICATOR

The **DISC IN** indicator appears whenever you load a compact disc into the player with CD Mode selected (**CD-TUNE** button).

#### 4. THREE-INCH CD SINGLE INDICATOR

The **CD3** indicator appears whenever you load a 3-inch CD single into the CD player.

#### 5. TRACK REPEAT INDICATOR

The **RPT** indicator appears whenever you select the Track Repeat feature (**RPT** button).

#### 6. COMPACT DISC PLAY INDICATOR

The play arrow indicator (**▶**) appears whenever you begin playback of a compact disc.

#### 7. DISC PROGRAM PLAY INDICATOR

The disc program play indicator (**P ▶**) appears whenever you have selected playback of pre-programmed CD tracks.

#### 8. AUTOMATIC STATION MEMORY INDICATOR

The Automatic Station Memory indicator (**ASM**) appears whenever you place the tuner into the Automatic Station Memory mode.

#### 9. SCAN TUNING INDICATOR (Radio Mode)

**INTRO SCAN INDICATOR (CD Mode)**  
In **Radio Mode**, the **SCAN** indicator appears whenever you select Scan tuning (**SCAN** button).

In **CD Mode**, the **SCAN** indicator appears whenever you select the Intro Scan feature (**SCAN** button).

#### 10. PRESET SCAN INDICATOR (Radio Mode Only)

The **P SCAN** indicator appears whenever you select the Preset Scan feature by pressing and holding the **SCAN** button.

#### 11. DISTANT MODE INDICATOR

The **DX** indicator appears whenever you switch the FM tuner into Distant reception (**LO/DX** button). When you select Local reception to capture only strong local FM stations, the **DX** indicator disappears from the LCD Readout Panel.

#### 12. FM STEREO INDICATOR

When the tuner is receiving an FM stereo signal, the **ST** indicator appears on the LCD Readout Panel. Whenever you select mono reception (**ST/MO** button), or if the broadcast material is in mono, the **ST** indicator will not appear.

#### 13. PRESET STATION IDENTIFICATION (Radio Mode) TRACK NUMBER INDICATOR (CD Mode)

In **Radio Mode**, the number indicates which Preset Memory (1-6) is being recalled or programmed.

In **CD Mode**, the number indicates the track being played.

#### 14. BAND INDICATOR

In **Radio Mode**, either an FM1, FM2 or AM indicator appears when you select a radio band (**BND** button).

#### 15. RADIO FREQUENCY (Radio Mode) ELAPSED TIME DISPLAY (CD Mode)

In **Radio Mode**, up to four numbers indicate the selected station's frequency.

In **CD Mode**, the digits indicate the elapsed time of the track being played. This display is also used in programming CD tracks. Refer to CD PLAYER OPERATION section for more details.

## OPERATION OF THE CD-303

In this section you will learn how to operate your CD-303 first as a CD Player, and then as a Radio Tuner.

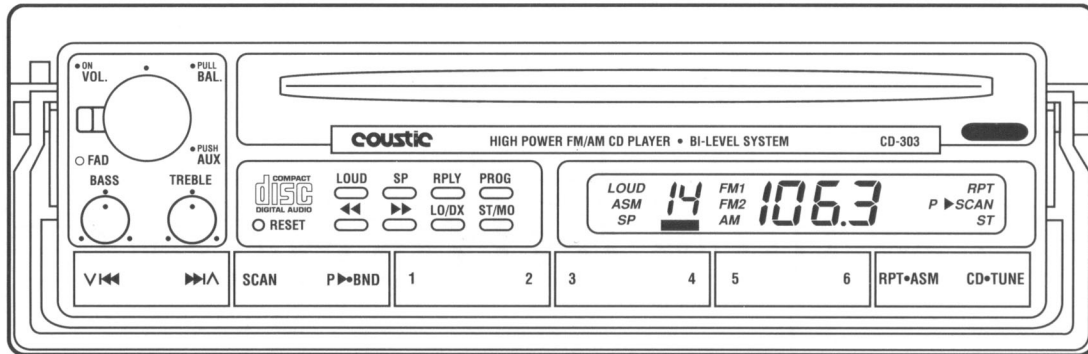

Figure 3. CD-303 Front Panel Controls

### CD PLAYER OPERATION

#### Floating Suspension Device

The CD-303 employs a unique floating suspension design that, when the unit is properly installed, allows it to perform perfectly under even severe road conditions. The INSTALLATION section has more detail about the Floating Suspension Device.

To protect the mechanism and your CD's from vibration damage, the laser pick-up head will temporarily retreat from its play position under extremely bad road conditions. The laser pick-up head will resume normal play in the same track position once road conditions become normal.

#### Moisture Condensation

When the vehicle's heater is used during periods of cold weather or when the weather is humid, water vapor may condense on the optical lens of the disc player, causing your unit to cease operation. If condensation appears to be keeping your player from operating, remove the compact disc and wait about one hour for the moisture to evaporate.

To operate your CD-303 in CD Mode, follow these steps:

#### Disc Play

1. First turn the power ON. Then gently insert a compact disc into the slot with the label facing upwards. The CD mechanism will automatically load the disc and immediately start playing the first track.

Observe that the **▶** and **DISC IN** indicators appear on the LCD Readout Panel. You will also see the track number and elapsed time of play in minutes and seconds.

Next, adjust the volume, balance, fader and tone controls to your listening preference.

**NOTE:** This unit will also play 3" compact discs (singles) without the use of an adaptor. When inserting a 3" disc into the CD player, the **CD3** indicator will appear on the display.

2. To eject a disc, press the Eject button once. The compact disc will eject halfway from the slot. At this point, you can remove the disc or resume play.

To resume play, gently push the disc back into the slot again and the unit will start playing the interrupted track.

3. In addition to the normal play function, your CD-303 can also perform AUTO CONTINUOUS PLAY (indefinite repeat of the entire disc). This feature automatically sets in whenever the end of the disc is reached, unless you select another function to defeat this action.

#### Intro Scan

1. Insert a disc (see step 1 under Disc Play).
2. Press the **SCAN** button once and observe the **SCAN** indicator appearing on the LCD Readout Panel. The CD Player will play the first track for 10 seconds before it scans to the beginning of the second track and plays it for 10 seconds, and so on.

When the last track has been scanned, the CD Player will return to scan the first track, starting over again. The **SCAN** function will continue unless you interrupt it by selecting another function or cancel it by pressing the **SCAN** button again. The CD player will then return to normal play mode.

#### Track Skip

1. Insert a disc (see step 1 under Disc Play).
2. Press the Forward Skip (**▶▶A**) button once to skip to the next track. The next track number will appear on the LCD Readout Panel. Press the Backward Skip (**◀◀A**) button to return to the start of the previous track.
3. To quickly access a distant track, simply hold down the Forward (**▶▶A**) or Backward (**◀◀A**) Skip button until you see the desired track number on the display.
4. The Track Skip feature stops when the last track is reached. To play the first track on a disc, simply press the **REPLAY** (**RPLY**) button.

## OPERATION OF THE CD-303

### Audible Music Search

1. Insert a disc (see step 1 under Disc Play).
2. To quickly audition a current track, press the Forward Search (▶▶) button. Notice that the elapsed time display on the LCD Readout Panel updates with the faster search speed.
3. If you continuously press and hold the Forward Search (▶▶) button, a faster search (up to 20 times normal play speed) will occur. The elapsed time readout on the display will also update according to the faster search speed.
4. To perform a backward search, press and hold the Backward Search (◀◀) button.
5. Search will stop at the end of the last track on the disc. To resume play, release the search button, and the player will start playing again with the first track.

### Shuffle Play

1. Insert a disc (see step 1 under Disc Play).
2. To start a random track playback, press the Shuffle Play (SP) button. The SP indicator will appear on the display to confirm your selection, and the disc player will randomly select a track on the disc for immediate playback.
3. To cancel Shuffle Play, simply press the SP button again, and normal playback will resume. The SP indicator will disappear from the display.

### Repeat Track

1. Insert a disc (see step 1 under Disc Play).
2. To repeat a track, press the Repeat Track (RPT) button once. The RPT indicator will appear on the display and the CD Player will continuously play the current track until you cancel the Repeat Track feature.
3. To cancel the Repeat Track feature, press the RPT button again. Notice that the RPT indicator disappears from the display.

### Programmable Memory

Your CD-303 player can store up to 16 CD tracks in its memory. The Memory feature lets you listen to a selection of favorite tracks from any CD. The programmed sequence will remain in memory as long as the disc remains loaded.

To use the Programmable Memory, follow these steps:

1. Insert a disc (see step 1 under Disc Play).
2. Press the Program (PROG) button once. The two digits that normally show elapsed Minutes will display "01" and begin to flash. At this point, you have 20 seconds to program the first track.

3. Use the Forward Skip (▶▶) or Backward Skip (◀◀) button to select tracks to be entered into the program. The two digits on the display that normally show elapsed seconds will display the track you have chosen.
4. When you want to store a track selection, simply press the PROG button again.
5. Notice that the Minutes display has changed to "02" as it begins to flash. Again, you have 20 seconds to enter your next selection into program memory 02. Repeat the process described in step 3 above, and press the PROG button again to store your next favorite track selection.
6. To store up to 16 selections, repeat the process described in steps 2 through 5 above. Each new track selection will be stored in the next sequential program memory.
7. When you have finished programming your track selections, press the Program Play (P▶BND) button once to start playback of your favorite tracks. The display will revert to normal play mode, and the P▶ indicator will appear on the display to confirm that Program Play is selected.
8. To cancel Program Play at any time, press the P▶BND button again. Normal play will resume immediately.
9. You can change the programmed tracks at any time in the following ways:
  - a. During programming - you can reprogram a memory first by pressing and holding the PROG button. The Minutes digit, indicating the program sequence, will display the capacity of programs (16 tracks maximum), return to the first program and begin to flash again. The Seconds digit will then display the track number stored in Program Memory 1. Use the Forward or Backward Skip buttons to select your new track for entry into Program Memory 1. Repeat steps 2 through 5 listed above for additional memory reprogramming.
  - b. During normal play or program play - you can reprogram a memory by first pressing the PROG button once. The Minutes digit will indicate Program Memory 1, and the Seconds digit will display the track number. Repeat steps 2 through 5 listed above to reprogram your favorite tracks.
10. The programmed sequence will remain in memory as long as the disc is NOT REMOVED from the slot.
11. For program play, you can use any of the functions described above, such as Repeat, Intro Scan, Forward and Backward Skip, etc.

**NOTE:** Program Play will NOT function if the disc is not programmed or the programmed disc is REMOVED from the slot.

## OPERATION OF THE CD-303

### RADIO OPERATION

To operate your CD-303 in Radio Mode, follow these steps:

#### Initial Settings

1. First turn the power ON. Then, select the desired radio band by pushing the **BND** button. Your selected band (**AM**, **FM1** or **FM2**) and the last-tuned frequency will be displayed on the LCD Readout Panel.
2. Adjust the volume, balance, fader and tone controls to your listening preference.

In Radio Mode, the CD-303 can be tuned three different ways:

#### Manual Tuning

1. Press the UP Tuning ( **▶▶** ) or Down Tuning ( **◀◀** ) button once to access the next higher or lower station.
2. To increase the speed of tuning, press and hold either the ( **▶▶** ) or ( **◀◀** ) button until a desired station is reached.

#### Automatic Seek Tuning

1. Press the Up Seek ( **▶▶▲** ) or Down Seek ( **▼◀◀** ) button once for Automatic Seek Tuning. The Tuner will immediately seek up or down the frequency band and stop at the next station.
2. Press either button again to start Automatic Seek Tuning for the next station.

#### Automatic Scan Tuning

1. Press the **SCAN** button once to activate Automatic Scan Tuning. The **SCAN** indicator will appear on the LCD Readout Panel and the Tuner will immediately scan up the frequency band, locking on the next station for five seconds. The locked station's frequency will be displayed on the LCD Readout Panel and will flash for approximately five seconds to confirm location of a scanned station.
2. The radio will continue to scan up the frequency band, locking onto the next radio station for five seconds. Automatic Scan Tuning will continue indefinitely until you cancel it.
3. When you want to continue to listen to a station found by Automatic Scan Tuning, simply press the **SCAN** button again to cancel the scanning process.

#### Memory

Your CD-303 can store 12 FM (6 each in FM1 and FM2) and 6 AM stations in its regular memory.

1. To store a station's frequency into memory, first select the desired band by pressing the **P▶BND** button and select a station with Automatic Seek Tuning, Automatic Scan Tuning, or manual tuning.
2. Press and hold one of the Station Preset buttons (1-6) for at least two seconds until you see the preset station number indicator (e.g., c1) appear on the LCD Readout. During this period, the radio will be muted temporarily.

3. Repeat steps 1 and 2 above to preset other desired station frequencies into other Station Preset memories.
4. To recall a station frequency from stored memory, first select the radio band by pressing the **P▶BND** button and then press the Station Preset button corresponding to the desired station. The recalled station number will immediately appear on the LCD Readout Panel and you will begin to hear the station's audio.

#### Automatic Station Memory

In addition to the regular memory capacity, your CD-303 can also store the 6 AM and 6 FM stations in a given area which emit the strongest signals. You can use this feature while traveling, without disrupting the regular memory.

1. Select the desired band by pressing the **P▶BND** button.
2. Next, press and hold the **ASM** button for at least two seconds until you see the **ASM** indicator flashing on the LCD Readout Panel. The radio will now search for the stronger local stations across the band. It will automatically store into memory those stations that have sufficient signal strength.

Even if there are fewer than 6 strong local stations available, the Automatic Station Memory will continue storing the next strongest stations across the frequency band until all 6 memories are stored.

After the process is completed, the radio will return to the last station memorized.

3. To recall any of the stored local stations, press the **ASM** button once. The **ASM** indicator will appear on the LCD Readout Panel. Then, press any one of Station Preset buttons, 1 to 6, to select a desired station.

#### Last Station Memory

Your CD-303 will automatically recall the last station played on that band whenever you turn the radio on or change bands. Also, when you select Automatic Station Memory, the radio will recall the station you last played.

#### Preset Scan/Automatic Station Memory Scan

1. To start a Preset Scan, press and hold the **SCAN** button until you see the frequency indicator flashing on the LCD Readout Panel. The radio will scan through the preset memory band, stopping to audition every stored station for five seconds.
2. When this function is activated, you will see frequency numbers for the recalled station preset flashing on the LCD readout panel. The **P SCAN** indicator and preset station number indicator will also appear.
3. To start an Automatic Station Memory Scan, press the **ASM** button once, and then press and hold the **SCAN** button for two seconds.
4. To stop any preset scan function, press the **SCAN** button again or press any desired preset memory button.

## OPERATION OF THE CD-303

### Auxiliary Input

By attaching the Auxiliary Input to a separate source unit (i.e., CD changer or portable cassette player), the CD-303 can receive signals transmitted by the source unit, and all tone and volume controls of the external source can be manipulated through the CD-303's front panel.

1. Press the **AUX** knob once to switch to Auxiliary Input Mode. CD/Radio indicators will disappear from the display showing that the unit is in Auxiliary Mode.
2. Adjust the volume, balance, fader, and tone controls on the CD-303 front panel to suit your listening preference.
3. Press the **AUX** knob again to resume CD/Radio Mode.

## CARE AND MAINTENANCE

### COMPACT DISC CARE AND MAINTENANCE

1. Use a soft cloth to wipe any fingerprints and dust from the disc's surface. Wipe in a straight motion from the inside to the outside of the disc. Unlike conventional records, compact discs do not have grooves to collect dust so wiping in a circular motion is not necessary.
2. Never use chemicals such as antistatic spray, benzine or thinners to clean compact discs. These solvents will permanently damage the disc's plastic surface.
3. Do not expose discs to direct sunlight, high temperature or high humidity for long periods.
4. Do not write or stick labels or papers on a disc's surface.
5. To protect discs from scratching, return them to their storage cases after use.

### FUSE REPLACEMENT

If unit does not operate when you switch power ON or the LCD Readout Panel does not light up, check or replace the fuse as follows:

1. Turn the power off.
2. Remove fuse from fuse socket on the filter box. Check the fuse and replace it, if necessary. Use only a standard blade fuse with a rating of 7.5 Amps.

## CD-303 INSTALLATION PREPARATION

### GENERAL PRECAUTIONS

1. ALWAYS DISCONNECT THE SYSTEM FROM THE BATTERY BEFORE ATTEMPTING TO MAKE OR ALTER ANY CONNECTIONS.
2. Be sure to follow the step-by-step directions, check all important points and have every item necessary for installation on hand.
3. Check to make sure the vehicle's battery is in good condition for proper operation of your CD-303.
4. The CD-303 is designed for use ONLY in 12-volt NEGATIVE GROUND electrical systems.

**CAUTION:** Installing this product in any positive ground electrical system could seriously damage the audio system, as well as void the product warranty.

5. A set of tools and hardware is required. Be sure to check the TOOLS REQUIRED list for any special tools that may be needed.
6. Do not install or use the CD-303 in any method other than that outlined in this manual. Doing so could reduce the performance capabilities of this product, as well as void the product warranty.

### REQUIRED TOOLS

1. Electric drill/drill bits
2. Saber saw/fine tooth metal cutting blades
3. Razor knife
4. Philips and flathead screwdrivers
5. Pliers (standard and needle nose)
6. Wire cutters/strippers
7. Wire crimping tool
8. Electrical tape or heat shrink tube for professional finish
9. Soldering iron and solder
10. Nylon tie wraps.
11. Volt/Ohm meter (VOM or DVM)

## CD-303 INSTALLATION

This section provides you with the Mechanical and Electrical Installation Procedures to successfully install your CD-303 in any vehicle. The Final System Check at the end of the section will help you test your installation.

### MECHANICAL INSTALLATION PROCEDURES

Mechanical Installation Procedures include Removal of Transit Screw, Mounting Location and Installation.

#### Removal of Transit Screw

In order to prevent any problems during transport, a transit screw has been attached to the top of the unit. Before installation, be sure to remove the transit screw (see Figure 4).

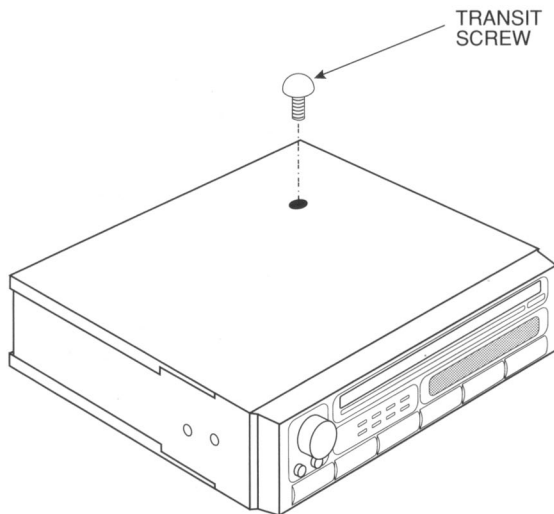

Figure 4. Removal of Transit Screw.

#### Mounting Location

1. Select a mounting location that is convenient and easily accessible (usually in the dash).
2. Do not mount unit near the engine or any heat-generating ducts. Doing so will cause damage to the unit, as well as void the product warranty.
3. The CD-303 is a standard DIN E chassis, requiring an opening of 2-1/8 inches (53 mm) x 7-1/16 inches (182 mm), as shown in Figure 3.
4. Make sure there is a clearance of at least seven inches (178 mm) behind the dash (see Figure 5).

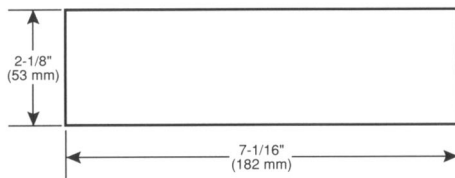

Figure 5. Opening Required

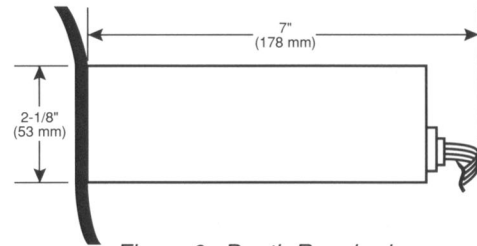

Figure 6. Depth Required.

#### Installation

1. If your car is a domestic model (Ford, GM, etc.), make sure there is enough room (i.e. width, height, and depth) before attempting installation. You may need an additional installation kit. If so, contact American International, Metra, Scosche, or your local Coustic dealer.
2. Before you mount the CD-303 in your car, check to make sure that the unit is level or that the mounting angle is not greater than 30° to the horizontal (see Figure 5). If the unit has to be mounted at an angle, make sure that the tilt is no more than 30°.

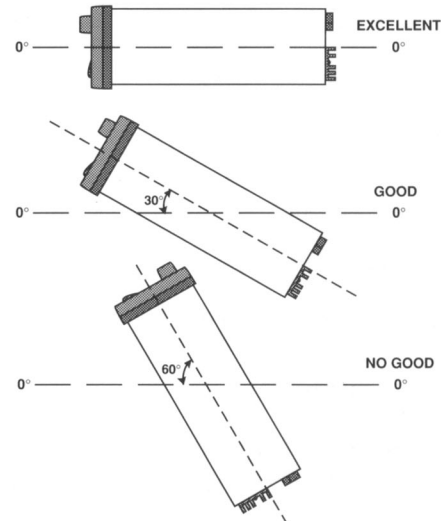

Figure 7. Mounting Less than 30° to Horizontal.

3. Use the CD-303 mounting sleeve to check the dash opening and depth. Make sure the mounting sleeve slides easily into the dash opening, but without any excessive play (no more than 1/16" or 1.5 mm on all sides).

**CAUTION:** Make sure that the mounting sleeve is correctly oriented, with the cables/connectors on the left-hand side.

## CD-303 INSTALLATION

4. In some vehicles, the firewall provides a bushing support for the rear of the sleeve. Check the firewall for this bushing support before installing the sleeve (see Figure 7). If the support is available, insert the rubber grommet (supplied) to the stud at the back of the sleeve and slide the sleeve into place as shown in Figure 8.

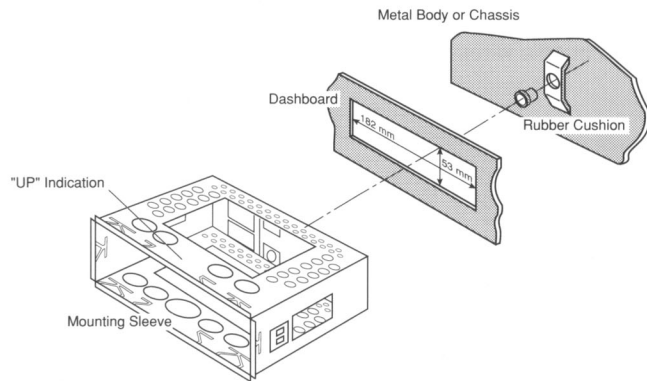

Figure 8. Bushing Support for the Mounting Sleeve.

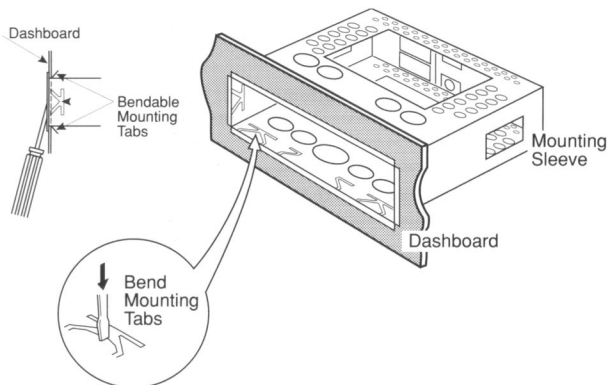

Figure 9. Securing the Mounting Sleeve.

5. Secure the mounting sleeve to the dashboard by bending the flanges 90°. If necessary, use a screwdriver and/or pair of needle nose pliers (see Figure 7).

**CAUTION: BE CAREFUL NOT TO SCRATCH THE DASHBOARD WHEN BENDING THE FLANGES.**

6. If you were able to secure the Mounting Sleeve properly in steps 4 and 5 above, skip this step and go on to step 7. Otherwise secure the rear of the sleeve to the vehicle by fastening the metal strap (supplied) as shown in Figure 10.
7. If there is enough space, mount the filter box to the firewall, with a tapping screw (see Figure 10).
8. After the sleeve has been firmly secured, insert the CD-303 chassis slowly into the sleeve. It will be locked securely by a spring-loaded catch on the left side of the unit.

9. You can remove the chassis by pushing the left side, raising the handle, and then pulling on it, as shown in Figure 11.

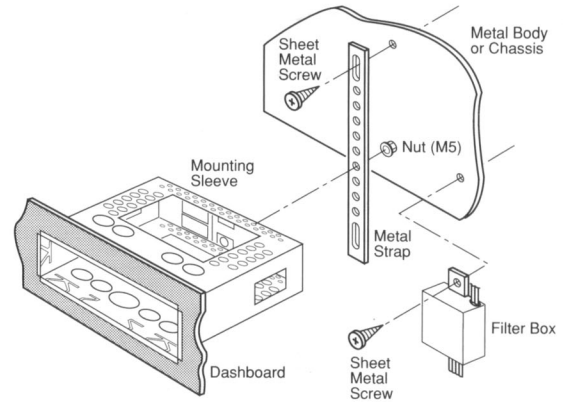

Figure 10. Securing the Rear of Mounting Sleeve.

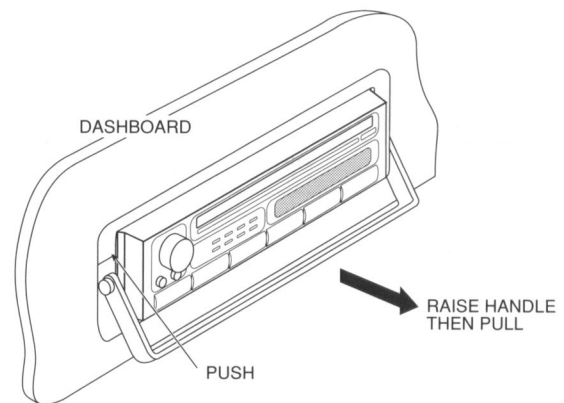

Figure 11. Removing the CD-303 chassis from the Mounting Sleeve.

## CD-303 INSTALLATION

### ELECTRICAL INSTALLATION PROCEDURES

Your Coustic CD-303 is equipped with its own electrical wiring harness. You can select from a wide variety of audio cable available on the market. Choose the size that fits your budget and performance preference.

#### Wiring Precautions

1. For safety purposes, first disconnect the battery ground cable before you start any electrical installation.
2. Verify your wiring connections from one component to the next. Make sure that you plug outputs into inputs, and not inputs into inputs.
3. Route all new wires with existing electrical wiring in your vehicle to conceal them from view. In order to have a neat and clean installation, you may have to remove kick panels, door sills, etc.

**CAUTION: DO NOT ROUTE AUDIO CABLE AND POWER CABLE TOGETHER! DOING SO CAN CAUSE ENGINE NOISE IN YOUR AUDIO SYSTEM.**

4. Remember exactly how you removed each part from the vehicle, so you can easily put each one back in its location. Try placing each piece of hardware you remove into one or more containers to help reduce the chance of losing important parts.
5. To both protect and conceal the wiring, we recommend using automotive flexible plastic tubing and plastic tie-wraps to bundle wires for ease of handling (see Figure 12).

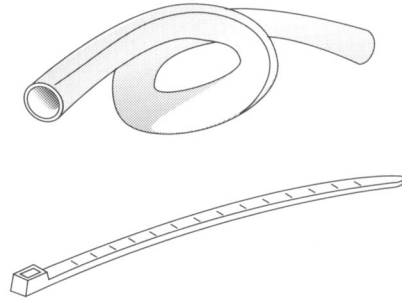

Figure 12. Flexible Plastic Tubing and Tie-wraps.

### WIRING DESCRIPTIONS

The following table lists the wiring code and the connection points used in the Electrical Installation of the CD-303.

ELECTRICAL	PRIME CONNECTION	DESCRIPTION
RED	SWITCHED +12 V DC	Connect to a switched constant +12 V DC source.
BLACK	GROUND	Connect to vehicle's chassis ground (bare metal).
BLUE	POWER ANTENNA / REMOTE AMPLIFIER TRIGGER	Connect to relay of electrical antenna (if available). If using CD-303 to turn on external amplifier, connect to remote triggering terminal of power amplifier.
WHITE	FRONT LEFT SPEAKER +	Connect to positive terminal (+) of front left speaker.
WHITE/BLACK	LEFT SPEAKER -	Connect to negative terminal (-) of left speakers.
GREEN	REAR LEFT SPEAKER +	Connect to positive terminal (+) of rear left speaker.
GRAY	FRONT RIGHT SPEAKER +	Connect to positive terminal (+) of front right speaker.
GRAY/BLACK	RIGHT SPEAKER-	Connect to negative terminal (-) of right speakers.
VIOLET	REAR RIGHT SPEAKER +	Connect to positive terminal (+) of rear right speaker.
ANTENNA INPUT	EXTERNAL ANTENNA TO CD-303	Connect from external antenna to CD-303.
FRONT LINE LEVEL OUTPUT (GRAY)	CD-303 TO EXTERNAL POWER AMPLIFIER	Connect from front outputs of CD-303 to external power amplifier.
REAR LINE LEVEL OUTPUT (BLACK)	CD-303 TO EXTERNAL POWER AMPLIFIER	Connect from rear outputs of CD-303 to external power amplifier.
AUXILIARY INPUT (BLACK)	CD-303 TO EXTERNAL SOURCE	Connect from auxiliary input of CD-303 to external source.



# CD-303 INSTALLATION

## Electrical Wiring Diagram

Use the Electrical Wiring Diagram shown in Figure 13 when you install the CD-303 in your car.

After you have performed the Final System Check, you can change the front panel illumination color by sliding the switch located on the left side of the chassis. This switches the illumination from amber to green or green to amber.

**CAUTION: THIS UNIT HAS A BUILT-IN POWER AMPLIFIER. DO NOT CONNECT ANY SPEAKER TERMINAL TO GROUND AND DO NOT SHORT ANY SPEAKER WIRES TOGETHER. IMPROPER GROUNDING AND SHORTING OF WIRES WILL DAMAGE UNIT. ALL POSITIVE AND NEGATIVE SPEAKER WIRE PAIRS FROM THIS RADIO MUST BE CONNECTED DIRECTLY TO EACH SPEAKER TERMINAL PAIR. TO AVOID UNNECESSARY DAMAGE TO UNIT, BE SURE TO CONNECT THE RED POWER WIRE (+12 V DC) FIRST.**

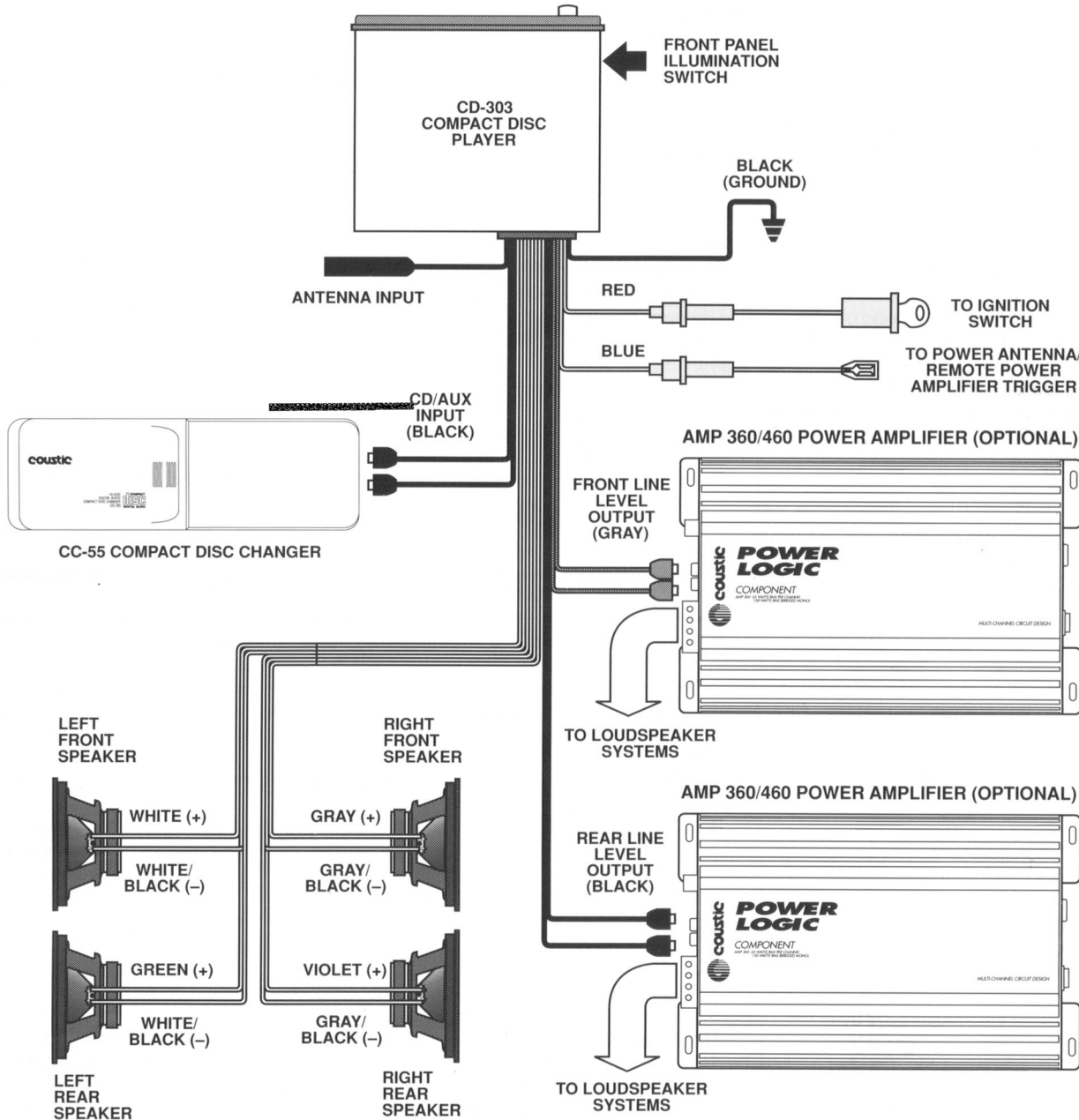

Figure 13. Electrical Wiring Diagram.

## FINAL SYSTEM CHECK

After you have successfully performed the Mechanical and Electrical Installation Procedures, your CD-303 will be ready for preliminary adjustment and testing. However, you must first connect the battery ground cable (refer to the ELECTRICAL INSTALLATION Section for details).

### Preliminary Tests

1. Adjust tone controls, balance control, and fader control to their center positions.
2. Turn the power ON.

**CAUTION: Do not overdrive the system; a surge of high power from amplifiers could damage audio components.**

3. Slowly turn the volume up and carefully listen or look for:

#### A. Obvious distortion:

If the sound is distorted, turn the power off and refer to the TROUBLE SHOOTING GUIDE at back of this manual.

#### B. No sound, no hiss, or total silence:

If you hear no sound and no hiss, turn the power off immediately! Double check all power connections. Use a Volt/Ohm meter (VOM) or Digital Volt Meter (DVM) to make sure there is good chassis ground for each component that needs to be grounded. Also check to see that the +12 V DC is connected to all power inputs. After making the necessary corrections, slowly turn power ON again. If symptoms still exist, refer to the TROUBLE SHOOTING GUIDE at back of this manual for additional help.

4. After you have successfully completed the above steps, turn the power off and proceed to the next section, Noise Check. Otherwise refer to the TROUBLE SHOOTING GUIDE below.

### Noise Check

Now check the entire audio system for noise with the following steps:

1. Start the engine.
2. Turn the audio system power ON.
3. "Rev" the engine and vary the volume of the audio system, while listening for any unwanted noise, like a whine or a ticking sound.
4. If you do hear a whine or ticking sound, turn both the audio system and engine off. Refer to the TROUBLE SHOOTING GUIDE below.
5. If the audio system does not emit any noise, double-check to see that the wiring cables are safely placed.

## TROUBLE SHOOTING GUIDE

SYMPTOM	PROBABLE CAUSES AND SOLUTIONS
1. The function keys do not work.	<ul style="list-style-type: none"> <li>• The built-in microprocessor is suffering from noise interference. Remove the compact disc. Then insert it again and press the RESET button.</li> </ul>
2. Erratic behavior in CD mode.	<ul style="list-style-type: none"> <li>• The mounting sleeve is not properly secured. Make sure the rear of the sleeve is properly supported (either by bushing support or metal strap).</li> </ul>
3. Music skips in the CD mode.	<ul style="list-style-type: none"> <li>• The installation angle is greater than 30 degrees. Re-install the unit at an angle less than 30 degrees.</li> <li>• The disc is extremely dirty. Clean the disc and try again.</li> </ul>
4. The CD sound quality is poor.	<ul style="list-style-type: none"> <li>• The disc is dirty. Clean the disc and try again.</li> <li>• The disc is defective. Try another disc.</li> </ul>
5. You cannot load disc or eject it.	<ul style="list-style-type: none"> <li>• Check to see if there is another disc already loaded. If so, remove the disc and insert the new one.</li> <li>• The temperature in the car is too high. Wait until interior cools off and try again.</li> <li>• There is condensation on the player's optical components. Turn the player off for an hour or longer and try again.</li> <li>• Check to see whether the disc you are trying to load is dirty. If so, try cleaning it or load another one.</li> </ul>

## TROUBLE SHOOTING GUIDE

SYMPTOM	PROBABLE CAUSES AND SOLUTIONS
6. SEE 1 indicator flashes on the LCD Readout Panel.	<ul style="list-style-type: none"><li>• The temperature inside the player is too high, and the internal protection circuit has shut down the CD section. Any loaded disc will automatically be ejected, and the unit will enter the Radio Mode. Wait until the interior of the car cools off, then insert the disc again.</li></ul>
7. SEE 3 indicator flashes on the LCD Readout Panel.	<ul style="list-style-type: none"><li>• The unit will not operate due to an internal fault. Press the <b>RESET</b> button to clear fault. If symptom persists, consult your Coustic dealer for additional help.</li></ul>
8. You hear a whining noise that increases or decreases as you vary the volume of all sound sources (FM, AM or CD). The engine is running, and you are listening to the audio system at a normal level.	<ul style="list-style-type: none"><li>• Install a 6-amp in-line filter on Red power wire of CD-303. If this procedure does not eliminate the noise, the alternator diodes or the voltage regulator may not be functioning properly and may need to be repaired or replaced.</li><li>• Check to make sure that the CD-303 chassis is properly grounded to vehicle's chassis ground.</li></ul>
9. You hear a "motor-boating" sound when the engine is running with the audio system volume set at a high level.	<ul style="list-style-type: none"><li>• Check the red power wire connection. Make sure it is connected directly to the battery.</li><li>• Check the battery and make sure the system's ground point makes good contact with the chassis ground (bare metal).</li></ul>
10. Audio system is not receiving power.	<ul style="list-style-type: none"><li>• Check to make sure battery cables are tightly connected.</li><li>• Check all fuses.</li><li>• Check all power wire connections.</li><li>• Use a Volt/Ohm meter to verify the system is receiving +12 V DC.</li></ul>
11. External Amplifier cannot be turned on by power antennae/ remote Amp trigger.	<ul style="list-style-type: none"><li>• Check to make sure that the in-line fuse is intact. Replace the fuse, if blown.</li></ul>
12. The CD-303 is very hot to the touch when the system is on with volume is set at normal listening level. As you increase the volume level, the sound goes off and on at even intervals.	<ul style="list-style-type: none"><li>• Check to see that the system's ground point makes a good contact with the chassis ground (bare metal).</li><li>• Speakers are shorted to ground. Use a Volt/Ohm meter to check the speaker connections and make the necessary corrections.</li></ul>
13. When the audio system is in CD MODE only and the engine is running, you hear a whining noise that increases and decreases as you vary the volume level.	<ul style="list-style-type: none"><li>• This is "radiated" noise, and the problem is NOT caused by the CD-303.</li><li>• Please contact your local retailer/installer since the solution is beyond the scope of this manual.</li></ul>
14. When audio system is in FM or AM mode and the engine is running, you hear a rapid ticking sound that increases and decreases as you vary the volume level.	<ul style="list-style-type: none"><li>• This is "radiated" spark noise, and the problem is NOT caused by the CD-303.</li><li>• Please contact your local retailer/installer since the solution is beyond the scope of this manual.</li></ul>
15. Audio system sounds o.k., but weak. Bass does not sound normal. When you adjust the balance control from left to right, you hear more bass at the center position than at the extreme positions.	<ul style="list-style-type: none"><li>• Speakers are wired "out of phase" to each other, causing the bass frequencies to cancel out.</li><li>• Check the wiring from radio to the speakers.</li><li>• Make sure the connections are routed "+" to "+" and "-" to "-".</li></ul>

## SPECIFICATIONS

### CD PLAYER SECTION

Quantization:	16 Bit D/A Converter
Sampling Frequency:	44.1 KHz (Four Times Oversampling)
Laser Pick-up:	Three Beam
S/N Ratio:	>90 dB
Dynamic Range:	>90 dB
Frequency Response:	4 to 20,000 Hz $\pm$ 2 dB
Channel Separation:	>65 dB
THD:	< 0.05 %

### RADIO SECTION

	<b>FM</b>	<b>AM</b>
Range:	87.5 to 107.9 MHz	530 to 1710 KHz
Usable Sensitivity:	2.0 $\mu$ V for S/N 30 dB	30 $\mu$ V for S/N 20 dB
I, F. Rejection:	75 dB	45 dB
Image Rejection:	60 dB	45 dB
Selectivity:	—	>100 dB
S/N Ratio:	60 dB	50 dB
Stereo Separation:	35 dB	NA

### GENERAL

Power Source:	13.8 volts DC negative ground
Input Current:	7.5 amps maximum
Distortion:	0.09% at 1 KHz, 1 Watt
Frequency Response:	20 to 25,000 Hz $\pm$ 5 dB
Bass Control:	$\pm$ 10 dB at 100 Hz
Treble Control:	$\pm$ 10 dB at 10 KHz
Loudness Control:	+6 dB at 100 Hz +6 dB at 10 KHz
Aux. Input Impedance:	22 K Ohms
Output Impedance	
Pre-amp Output:	500 mV at 1 K Ohms
Speaker Output:	2 to 4 Ohms
Output Power:	4 x 14 Watts RMS
Chassis Dimensions:	7" W x 2" H x 6" D (178 W x 50 H x 153 D mm)

**DUE TO ONGOING RESEARCH AND PRODUCT IMPROVEMENTS, WE RESERVE THE RIGHT TO UPDATE THE LISTED FEATURES AND SPECIFICATIONS WITHOUT ANY PRIOR NOTICE.**

## Free Manuals Download Website

<http://myh66.com>

<http://usermanuals.us>

<http://www.somanuals.com>

<http://www.4manuals.cc>

<http://www.manual-lib.com>

<http://www.404manual.com>

<http://www.luxmanual.com>

<http://aubethermostatmanual.com>

Golf course search by state

<http://golfingnear.com>

Email search by domain

<http://emailbydomain.com>

Auto manuals search

<http://auto.somanuals.com>

TV manuals search

<http://tv.somanuals.com>