

Owner's Manual

CRAFTSMAN

8.5 Horse Power

CHIPPER-SHREDDER

Model No.

247.775880

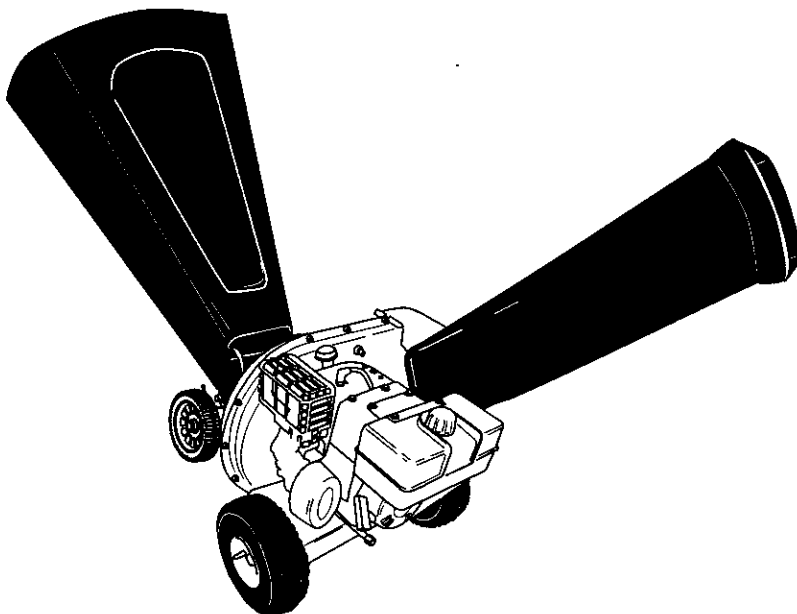

CAUTION: Before using this product, read this manual and follow all Safety Rules and Operating Instructions.

Sears, Roebuck and Co., Hoffman Estates, IL 60179, U.S.A.

TABLE OF CONTENTS

Content	Page	Content	Page
Warranty Information	2	Service & Adjustment	14
Safe Operation Practices	3	Off-Season Storage	16
Assembly	5	Trouble-Shooting	17
Operation	8	Repair Parts	18
Maintenance	11		

WARRANTY INFORMATION

One-Year Warranty on Craftsman Chipper-Shredder

For one year from the date of purchase, when this Craftsman chipper-shredder is maintained, lubricated, and tuned up according to the operating and maintenance instructions in the owner's manual, Sears will repair, free of charge, any defect in material or workmanship.

This warranty excludes blades, chipper blades, flails, air cleaners, spark plugs, catcher bags and tires which are expendable parts and become worn during normal use.

If this chipper-shredder is used for commercial or rental purposes, this warranty applies for only 30 days from the date of purchase.

WARRANTY SERVICE IS AVAILABLE BY CONTACTING THE NEAREST SEARS SERVICE CENTER IN THE UNITED STATES. THIS WARRANTY APPLIES ONLY WHILE THIS PRODUCT IS IN USE IN THE UNITED STATES.

This warranty gives you specific legal rights, and you may also have other rights which vary from state to state. Sears, Roebuck and Co., D/817WA, Hoffman Estates, IL 60179

ACCESSORIES

These accessories were available when the chipper-shredder was purchased. They are also available at most Sears retail outlets, and service centers. Most Sears stores can order repair parts for you when you provide the model number of your Craftsman chipper-shredder.

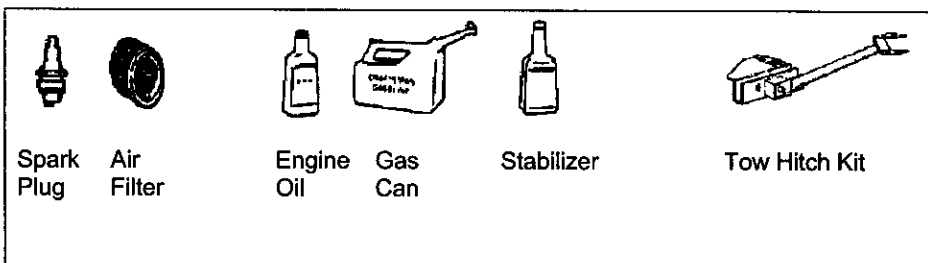

PRODUCT SPECIFICATION

<p>HORSEPOWER: 8.5 H.P.</p> <p>CRANKCASE CAPACITY: 26oz. SAE 30 ENGINE OIL</p> <p>FUEL TANK CAPACITY: 4 Quart (UNLEADED)</p> <p>SPARK PLUG: Champion (N4C)</p> <p>GAP: .030</p> <p>TIRE PRESSURE: 24 PSI</p>	<p>Model Number247.775880.....</p> <p>Serial Number.....</p> <p>Date of Purchase</p> <p>Record both serial number and date of purchase and keep in a safe place for future reference.</p>
--	---

SAFE OPERATION PRACTICES



This symbol points out important safety instructions which, if not followed, could endanger the personal safety and/or property of yourself and others. Read and follow all instructions in this manual before attempting to operate your chipper shredder. Failure to comply with these instructions may result in personal injury. When you see this symbol—heed its warning.



DANGER:

Your chipper-shredder was built to be operated according to the rules for safe operation in this manual. As with any type of power equipment, carelessness or error on the part of the operator can result in serious injury. If you violate any of these rules, you may cause serious injury to yourself or others.



WARNING: The Engine Exhaust from this product contains chemicals known to the State of California to cause cancer, birth defects or other reproductive harm.

GENERAL OPERATION

- Read this owner's guide carefully in its entirety before attempting to assemble this machine. Read, understand, and follow all instructions on the machine and in the manual(s) before operation. Be completely familiar with the controls and the proper use of the machine before operating it. Keep this manual in a safe place for future and regular reference and for ordering replacement parts.
- Your chipper-shredder is a powerful tool, not a plaything. Therefore, exercise extreme caution at all times. Your unit has been designed to perform two jobs; to chip and shred vegetation found in a normal yard. Do not use it for any other purpose.
- Never allow children under age 16 to operate the unit. Children 16 years and older should only operate the unit under close parental supervision. Only responsible individuals who are familiar with these rules of safe operation should be allowed to use your unit.
- Keep the area of operation clear of all persons, particularly small children and pets. Stop the engine when they are in the vicinity of the unit. Keep work area clean and clear of branches or obstacles which could cause you to stumble or fall.
- When feeding material into this equipment, be extremely careful that pieces of metal, rocks, bottles, cans or other foreign objects are not included. Personal injury or damage to the machine could result.
- Always wear safety glasses or safety goggles, during operation and while performing an adjustment or repair, to protect eyes from foreign objects that may be thrown from the machine.
- Wear sturdy, rough-soled work shoes and close fitting slacks and shirt. Shirt and slacks that cover the arms and legs and steel-toed shoes are recommended. Do not wear loose fitting clothes or jewelry and secure hair so it is above shoulder length. They can be caught in moving parts. Never operate a unit in bare feet, sandals or sneakers. Wear gloves when feeding material in the chipper chute or shredder hopper.
- Never place your hands, feet, or any part of your body into the shredder hopper, chipper chute, discharge opening, or near any moving part while the engine is running. Keep clear of the discharge opening at all times. If it becomes necessary to push material into the chipper chute or shredder hopper, use a small diameter stick, NOT YOUR HANDS.
- If it is necessary for any reason to unclog the feed intake or discharge openings or to inspect or repair any part of the machine where a moving part can come in contact with your body or clothing, stop the machine, allow it to cool, disconnect the spark plug wire from the spark plug and move it away from the spark plug before attempting to unclog, inspect or repair.
- Do not operate unit while under the influence of alcohol or drugs.
- The machine should only be operated on a level surface. Never operate your unit on a slippery, wet, muddy or icy surface. Keep your work area clean and clear of branches or obstacles which could cause you to stumble and fall. Do not overreach. Maintaining proper footing and balance is essential to preventing accidents.
- Do not allow an accumulation of processed material to build up in the discharge area as this will prevent proper discharge and can result in kick-back from the chipper chute.
- Keep your face and body back from chipper chute to avoid accidental bounce back of any material.
- Do not transport machine while engine is running.
- If your cutting mechanism strikes a foreign object or if your machine should start making an unusual noise or vibration, immediately stop the engine and allow the machine to come to a complete stop. Disconnect the spark plug wire and move it away from the spark plug. Take the following steps.
 - a. Inspect for damage.
 - b. Repair or replace any damaged parts.
 - c. Check for any loose parts and tighten to assure continued safe operation.
- Never attempt to attach or remove catcher bag when engine is running. Shut the engine off and wait for the

impeller to come to a complete stop. The impeller continues to rotate for a few seconds after the engine is shut off. Never place any part of the body in the impeller area until you are sure the impeller has stopped rotating.

- Muffler and engine become hot and can cause a burn. Do not touch.
- Do not allow leaves or other debris to build-up on engine's muffler. The debris could ignite and cause a fire.
- Do not attempt to shred or chip material larger than specified in this manual. Personal injury or damage to the machine could result.
- Do not operate engine if air cleaner or cover over carburetor air-intake is removed, except for adjustment. Removal of such parts could create a fire hazard.
- Only use accessories approved for this machine by the manufacturer. Read, understand, and follow all instructions provided with the approved accessory.
- If situations occur which are not covered by this manual, use care and good judgment. Contact your dealer for assistance.
- Keep discharge chute deflector, chipper chute door, and all other guards and safety devices in place and operating properly.
- Only operate unit in good daylight. Do not operate unit at night or in dark areas where your vision may be impaired.

CHILDREN

Tragic accidents can occur if the operator is not alert to the presence of small children. Children are often attracted to the chipper-shredder and the chipping and shredding activity. Never assume that children will remain where you last saw them.

- Keep children out of the work area and under the watchful eye of a responsible adult other than the operator.
- Be alert and turn the unit off if a child enters the area.
- Never allow children under the age of 16 to operate the chipper-shredder.

SERVICE

- Use extreme care in handling gasoline and other fuels. They are extremely flammable and the vapors are explosive.
 - a. Store fuel and oil in approved containers, away from heat and open flame, and out of the reach of children. Check and add fuel before starting the engine. Never remove gas cap or add fuel while the engine is running. Allow engine to cool at



This unit is equipped with an internal combustion engine and should not be used on or near any unimproved forest-covered, brush-covered or grass-covered land unless the engine's exhaust system is equipped with a spark arrester meeting applicable local or state laws (if any). If a spark arrester is used, it should be maintained in effective working order by the operator.

In the State of California the above is required by law (Section 4442 of the California Public Resources Code). Other states may have similar laws. Federal laws apply on federal lands. A spark arrester for the muffler is available through your nearest Sears Authorized Service Center (See the REPAIR PARTS section of this manual.)

- a. least two minutes before refueling.
- b. Replace gasoline cap securely and wipe off any spilled gasoline before starting the engine as it may cause a fire or explosion.
- c. Extinguish all cigarettes, cigars, pipes and other sources of ignition.
- d. Never refuel unit indoors because flammable vapors will accumulate in the area.
- e. Never store the machine or fuel container inside where there is an open flame or spark such as a gas hot water heater, space heater, clothes dryer or furnace.

- Never run your machine in an enclosed area as the exhaust from the engine contains carbon monoxide, which is an odorless, tasteless and deadly poisonous gas.
- To reduce fire hazard, keep engine and muffler free of leaves, grass, and other debris build-up. Clean up fuel and oil spillage. Allow unit to cool at least 5 minutes before storing.
- Before cleaning, repairing, or inspecting, make certain the impeller and all moving parts have stopped. Disconnect the spark plug wire and keep wire away from spark plug to prevent accidental starting. Do not use flammable solutions to clean air filter.
- Check the blade and engine mounting screws at frequent intervals for proper tightness. Also visually inspect blades for wear and/or damage (e.g., bent, cracked). Replace with blades which meet original equipment specifications.
- Keep all nuts, bolts, and screws tight to be sure the equipment is in safe working condition.
- Never tamper with safety devices. Check their proper operation regularly.
- After striking a foreign object, immediately stop the engine, disconnect the spark plug wire from the spark plug, and thoroughly inspect the unit for any damage. Repair damage before starting and operating unit.
- Do not alter or tamper with the engine's governor setting. The governor controls the maximum safe operating speed of the engine. Over-speeding the engine is dangerous and will cause damage to the engine and to other moving parts of the machine.

YOUR RESPONSIBILITY



Restrict the use of this power machine to persons who read, understand and follow the warnings and instructions in this manual and on the machine.

SAVE THESE INSTRUCTIONS FOR FUTURE REFERENCE

ASSEMBLY

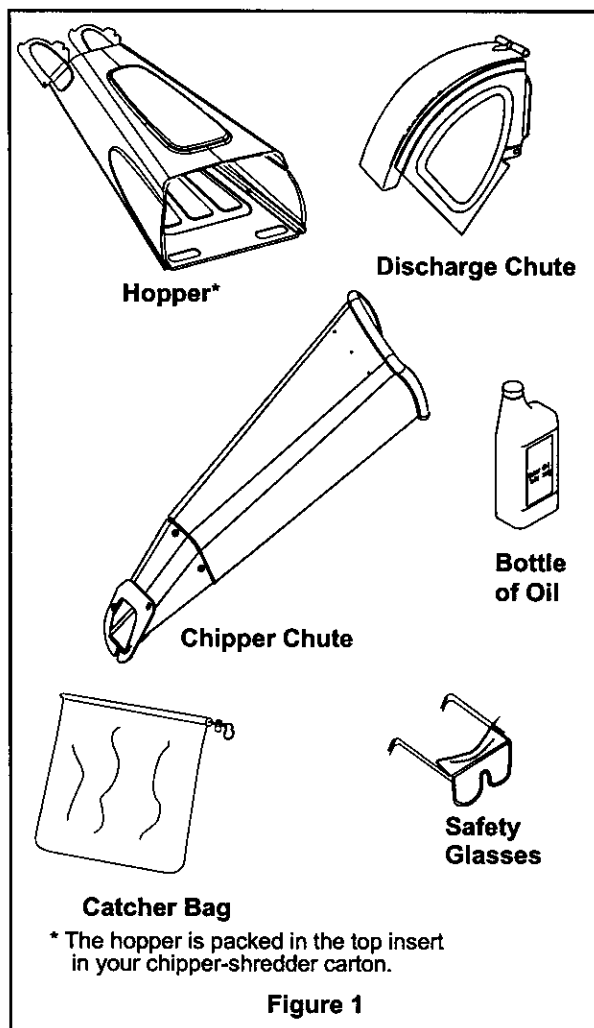

IMPORTANT: This unit is shipped **without gasoline or oil** in the engine. After assembly, see **OPERATION** section of this manual for proper fuel and engine oil fill-up.

NOTE: To determine right and left hand sides of your chipper-shredder, stand behind the unit with the engine farthest away from you.

Your chipper-shredder has been completely assembled at the factory, except for the hopper assembly, chipper chute, discharge chute and the catcher bag. These parts are shipped loose in the carton. A pair of safety glasses and a bottle of oil are also included in the carton.

UNPACKING FROM CARTON

- Cut the corners of the carton.
- Remove all packing inserts.

- Remove all loose parts including owner's manual. See figure 1.
- Roll chipper-shredder out of the carton.
- Make certain all parts and literature have been removed before the carton is discarded.

LOOSE PARTS

(Refer to figure 1.)

- a. Hopper Assembly
- b. Discharge Chute
- c. Chipper Chute
- d. Catcher Bag
- e. Bottle of Oil
- f. Safety Glasses
- g. Owner's Manual (not shown in figure 1)

TOOLS REQUIRED

1. 1/2" or Adjustable Wrenches
2. 7/16" or Adjustable Wrenches
3. 9/16" or Adjustable Wrenches
4. Funnel

DISCONNECTING SPARK PLUG

- Disconnect the spark plug wire and move it away from the spark plug before assembling the chipper-shredder. See figure 2.

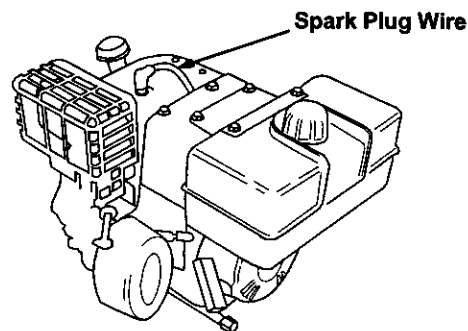

ATTACHING DISCHARGE CHUTE

- Remove the wing knobs from each side of the discharge opening on the chipper-shredder. See figure 3.
- Using two 7/16" wrenches, remove hex lock nut, two spacers, and the hex bolt from top of the housing assembly. For easy assembly, do not remove the second spacer from the hex bolt.
- Place the discharge chute in position on the discharge opening. Insert hex bolt and spacer

through hinge on discharge chute and housing (spacer fits inside of hinge). See figure 3 inset.

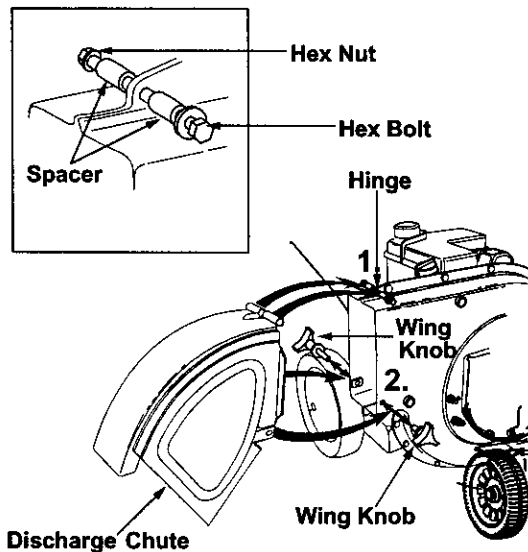

Figure 3

- Place second spacer over hex bolt inside the other part of the hinge. Secure with hex lock nut. Tighten securely.
- Secure both sides of discharge chute to housing using wing knobs that you earlier removed. Tighten wing knobs.

ATTACHING HOPPER ASSEMBLY

- Remove the 8-3/8" long hex bolt and the hex nut from the bottom of the inlet guide opening. See figure 4 inset.
- Place the hopper assembly on the ground and hold it in the position shown in step 1 in figure 4.
- Holding the hopper, push hopper pivot door down inside the hopper. See figure 4.
- Slide the hopper assembly towards the chipper-shredder housing so that the upper guide on the hopper assembly slides **under** the stop washer on each side of the inlet guide. See figure 4.
- Align the two holes (one on each side) of the lower hopper with the two holes (one on each side) of the inlet guide. See figure 4 inset.
- Insert the hex bolt (that you earlier removed) from the left through the hole on the hopper and the inlet guide. Insert the hex nut onto the bolt from the other side. See figure 4 inset.
- Tighten the bolt till the lock nut is engaged. Make sure to remove sideplay from the bolt, but the hopper should be able to pivot.

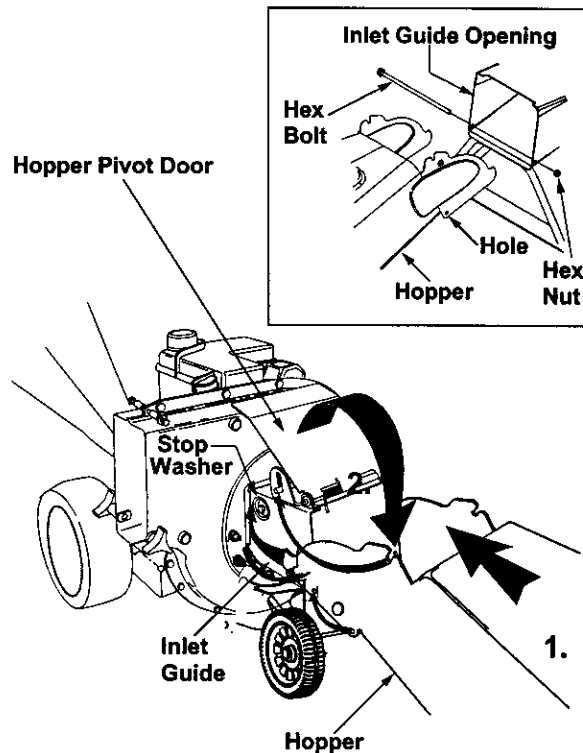

Figure 4

- To **raise** the hopper, hold the hopper by the hand-hold and lift it up till it clicks into position.
- To **lower** the hopper, hold the hopper by the hand-hold and pull the release bar. The hopper should drop down. See figure 5.

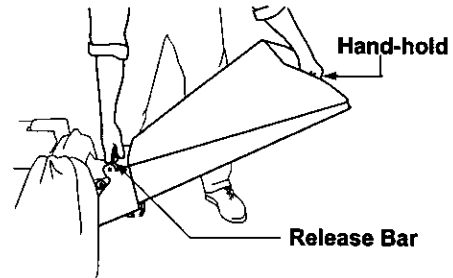

Figure 5

The flap control rod is already attached to the hopper at the top. The other end of the rod has to be attached to the stop washer on the inlet guide. See figure 6.

- Raise the hopper till it clicks into position.
- Unscrew the shoulder bolt from the stop washer on the inlet guide. See figure 6.
- Align the loose end of the flap control rod with the stop washer on the inlet guide.
- Slide the shoulder bolt through the opening in the flap control rod. Secure tightly. See figure 6.



WARNING: This flap control rod is a safety device to hold the flap in place inside the hopper while shredding branches. **Do not operate** the chipper-shredder without properly attaching this flap control rod to the unit.

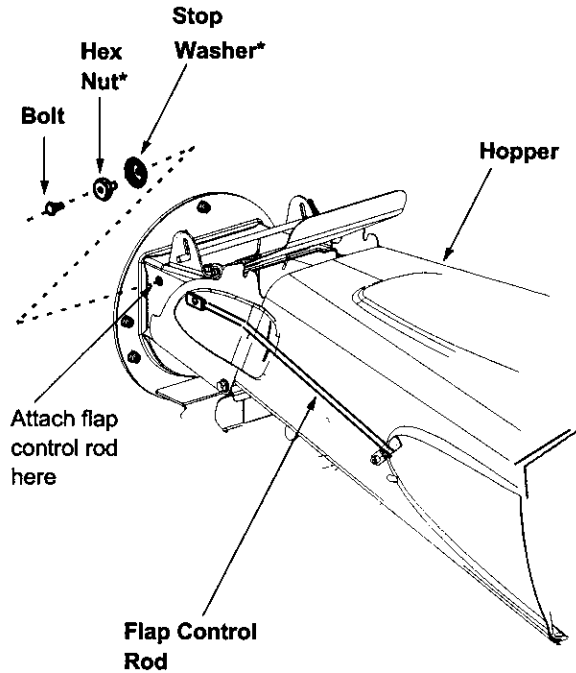

* Do not remove these hardware from the inlet guide assembly while attaching the flap control rod.

Figure 6

ATTACHING THE CHIPPER CHUTE

- Your unit is shipped with one end of the brace already secured to the lower frame. Loosen the bolts securing the brace to the frame.
- Remove the three cupped washers and hex nuts from the weld studs beside the opening on the left side of the housing. See figure 7.
- Remove the two sets of hex bolt, lock nut, and flat washer from the two holes on the upper end of the brace as shown in figure 7.
- Place the chipper chute over the weld studs so the slot on the chute is towards the bottom. Align the three holes at the bottom of the chute with the three weld studs.
- Secure with the three pairs of cupped washers and hex nuts that you earlier removed. Do not tighten the nuts at this time. Make sure to place the cupped side of the washer against the chipper chute.
- Align the holes towards the front opening of the chute with the holes on the brace. See figure 7.

- Insert one each of the hex bolts, lock nuts, and flat washers (that you earlier removed) through each hole in the chute and the brace. Tighten these bolts to secure brace to the chute.
- Tighten bolts securing the brace to the lower frame. These bolts had been removed earlier.
- Tighten the three nuts on the weld studs.

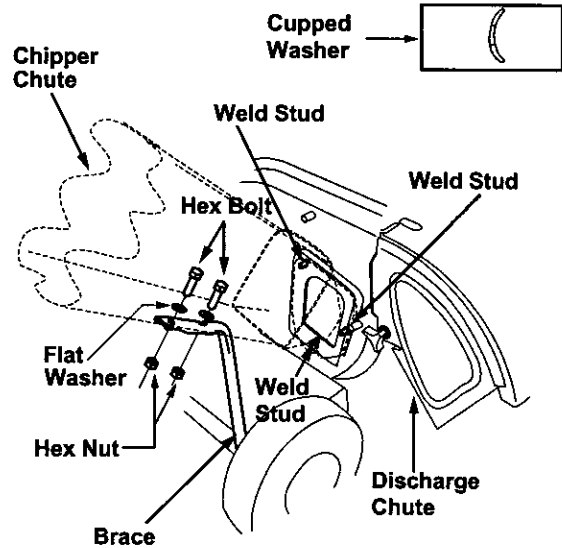

Figure 7

ATTACHING THE CATCHER BAG

Your chipper-shredder is equipped with a catcher bag to catch the shredded material.

- To attach the bag, place the opening of the bag over the chute deflector and the chute flange. Make sure it completely covers the chute deflector.
- Depress the plunger on the drawstring, and pull on the drawstring until the bag is tight around the chute opening. Release plunger to lock it into position. See figure 8.

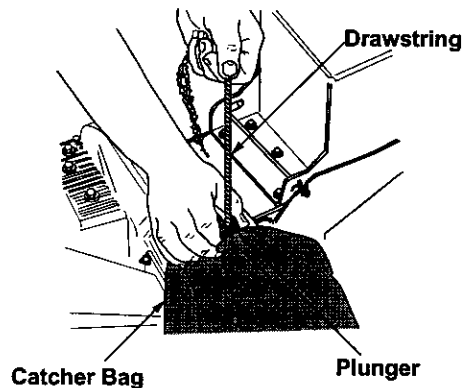

Figure 8

OPERATION

Read this owner's manual and safety rules before operating your chipper-shredder. Compare the illustration in figure 9 with your chipper-shredder to familiarize yourself with the location of various controls and adjustments. Save this manual for future reference.



The operation of any chipper-shredder can result in foreign objects being thrown into the eyes, which can result in severe eye damage. **Always wear safety glasses** provided with the chipper-shredder before chipping or shredding, or while performing any adjustments or repairs.

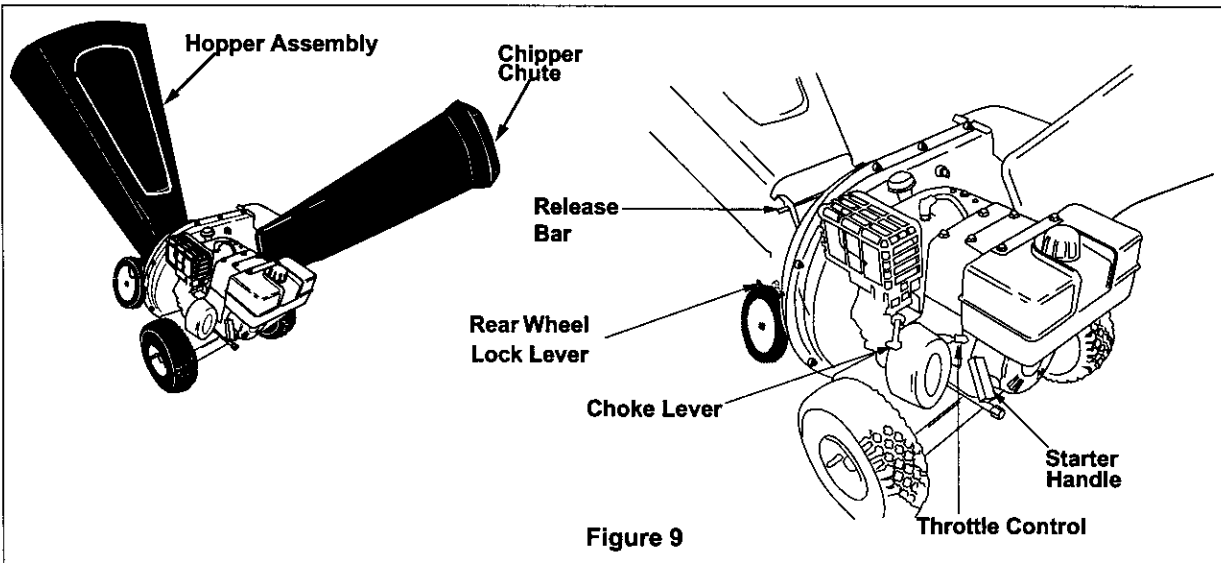

Figure 9

OPERATING CONTROLS

(Refer to Figure 9.)

Release Bar

Used to release the hopper when raising or lowering.

Choke Lever

Used to enrich the fuel mixture in the carburetor when starting a cold engine.

Starter Handle

Used to manually start the engine.

Hopper Assembly

Allows leaves and small branches upto 1" diameter to be fed into the impeller for chipping and shredding. Lower the hopper to collect raked material for shredding.

Throttle Control

Regulates speed of the engine.

Chipper Chute

Allows bulky vegetation like stalks or heavy branches upto 3" diameter to be fed into the impeller for chipping and shredding.

Catcher Bag (not shown)

Used to collect the shredded material.

Rear Wheel Lock Lever

Used to lock the rear wheels from moving.

Stopping Engine

Move throttle control lever to STOP position. Disconnect spark plug wire and move away from spark plug to prevent accidental starting.

MEETS ANSI SAFETY STANDARDS

Sears chipper-shredders conform to the safety standard B 71.6 -1990 of the American National Standards Institute.



WARNING: Before using your chipper-shredder, again refer to the **safety rules on pages 3 and 4** of this manual. **Always be careful.**

GAS AND OIL FILL-UP

Oil (Packed with unit)

- Only use high quality detergent oil rated with API service classification SF, SG or SH. Select the oil's viscosity grade according to your expected operating temperature. Follow the chart below.

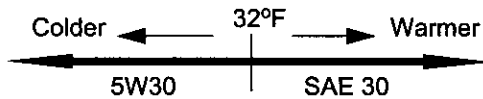

NOTE: Although multi-viscosity oils (5W30, 10W30, etc.) improve starting in cold weather, these multiviscosity oils will result in increased oil consumption when used above 32°F. Check the oil level more frequently to avoid possible engine damage from running low on oil.

Fill engine with oil as follows.

- Remove oil fill dipstick. See figure 10.

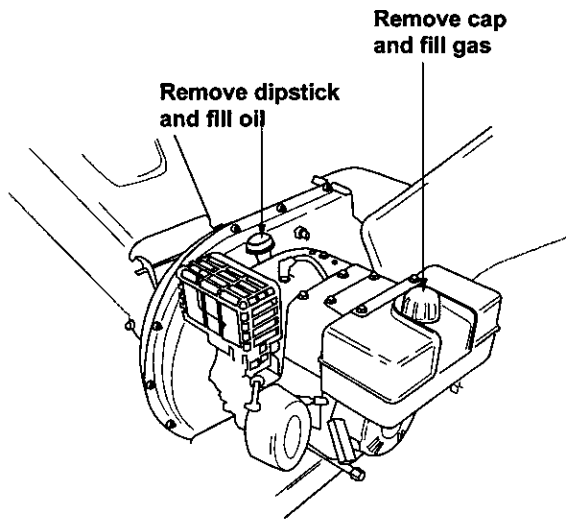

Figure 10

- With chipper-shredder on level ground, use a funnel to fill engine with oil to FULL mark on dipstick. Capacity is approximately 26 ounces. Be careful not to overfill.
- Check oil level.

- Add oil if necessary. Replace dipstick and tighten.

NOTE: Do not overfill. Oil bottle packed with unit contains 26 oz. of oil.

Gasoline

WARNING: Experience indicates that alcohol blended fuels (called gasohol or using ethanol or methanol) can attract moisture which leads to separation and formation of acids during storage. Acidic gas can damage the fuel system of an engine while in storage. To avoid engine problems, the fuel system should be **emptied before storage** for 30 days or longer. Drain the gas tank, start the engine and let it run until the fuel lines and carburetor are empty. Use fresh fuel next season. See STORAGE instructions for additional information. **Never use engine or carburetor cleaner products in the fuel tank or permanent damage may occur.**

Fill gas tank with gas as follows.

- Remove fuel cap. See figure 10.
- Make sure the container (from which you will pour the gasoline) is clean and free from rust or foreign particles. Never use gasoline that may be stale from long periods of storage in the container.
- Fill fuel tank with clean, fresh, lead-free automotive gasoline. DO NOT use Ethyl or high octane gasoline. See figure 10.
- Replace fuel cap.



WARNING: Do not fill closer than 1/2 inch of top of fuel tank to prevent spills and to allow for fuel expansion. If gasoline is accidentally spilled, move chipper-shredder away from area of spill. Avoid creating any source of ignition until gasoline vapors have disappeared.

- Check the fuel level periodically to avoid running out of gasoline while operating the chipper-shredder.
- If the unit runs out of gas as it is shredding or chipping, it may be necessary to unclog the unit before it can be restarted. Refer to "Removing the Flail Screen" instructions in SERVICE AND ADJUSTMENT section.

STARTING ENGINE



WARNING: Be sure **no one other than the operator** is standing near the chipper-shredder while starting or operating the unit. **Do not operate** this chipper-shredder unless the chute deflector has been properly installed and secured with hand knobs.

NOTE: To prevent the unit from sliding, place your foot firmly against the tire.

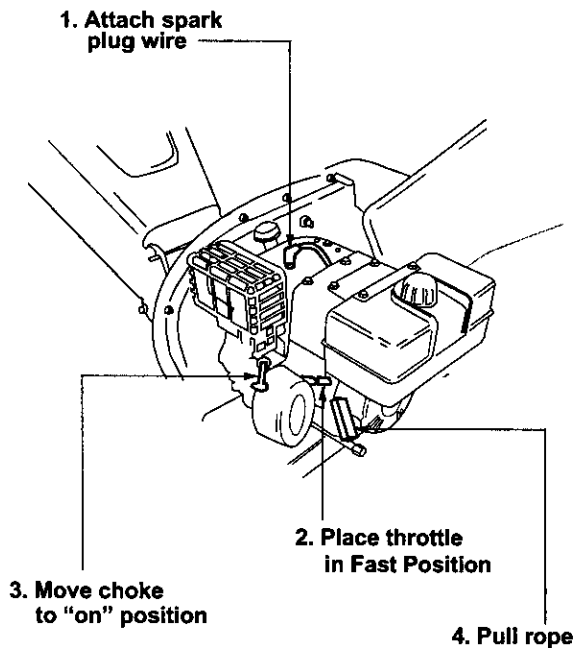

Figure 11

- Attach spark plug wire and rubber boot to spark plug. See figure 11.
- Place throttle in FAST position. See figure 11.
- Move choke lever to CHOKE position (in the direction of the arrow) as shown.
- If restarting a warm engine **after a short shutdown**, move choke lever to "No Choke" position.
- Grasp starter handle and pull rope out slowly until engine reaches start of compression cycle (rope will pull slightly harder at this point). Let the rope rewind slowly. Pull rope with a rapid full arm stroke. Let rope return to starter slowly. See figure 11.
- When engine starts, move choke lever to half choke position until engine runs smoothly and then to No Choke position.
- If engine **fails to start** after three pulls, move choke lever to No Choke position and pull starter rope again.
- If engine fires, but **does not continue to run**, move choke lever to Full Choke position and pull rope again.
- Move choke lever to OFF position as engine warms up.

NOTE: A noise will be heard when finding the start of the compression cycle. This noise is caused by the

flails and fingers which are part of the shredding mechanism falling into place, and should be expected. In addition, the flails and fingers will be noisy after the engine is started, until the impeller reaches full speed.

STOPPING ENGINE

- Move starter switch to OFF position.
- Disconnect spark plug wire and move away from spark plug to prevent accidental starting.

USING YOUR CHIPPER-SHREDDER



WARNING: Do not attempt to shred or chip any material other than vegetation found in a normal yard (i.e., branches, leaves, twigs, etc.).

- The chipper-shredder is designed for two different methods of operation.
 - a. Leaves and small branches up to 1/2" diameter (maximum) can be fed into the hopper assembly when it is in the raised or lowered position. See figure 12.
 - b. Bulky material, such as stalks or heavy branches, up to 3" in diameter should be fed into the chipper chute. See figure 12.



WARNING: Do not put material larger than is specified into the hopper, and/or into the chipper chute. Personal injury or damage to the machine could result.

- If it becomes necessary to push material into the chipper-shredder, use a small diameter stick – NOT YOUR HANDS. The stick should be small enough that it will be ground up if it gets into the impeller assembly.

LOWER THE HOPPER ASSEMBLY

- To lower the hopper assembly, use one hand to grasp the hand-hold at the top of the hopper assembly and lift slightly. See figure 5.
- Pull up on the release bar, and lower the hopper assembly to the ground. Release the bar. See figure 5.



WARNING: Never remove chute deflector till the unit has completely stopped. **Never shut off the engine until all chipping is completed.**

For best performance, it is important to keep the shredding blade and the chipper blades sharp. If the composition of the material being discharged

changes (becomes stringy, etc.) or if the rate at which the material is discharged slows down considerably, it is likely that the shredding blade and/or chipper blades are dull and need to be sharpened or replaced. Refer to Service and Adjustments section. **IMPORTANT:** There is a flail screen located inside the housing in the discharge area. If the flail screen becomes clogged, remove and clean as instructed in the Service and Adjustments section.



WARNING: The chipper-shredder discharges materials with considerable velocity. **Keep away** from the area around the discharge chute. Always **stop the engine** and disconnect spark plug wire when removing or attaching the bag, changing containers, or removing the shredded material. Wear safety glasses and gloves whenever using your chipper-shredder.

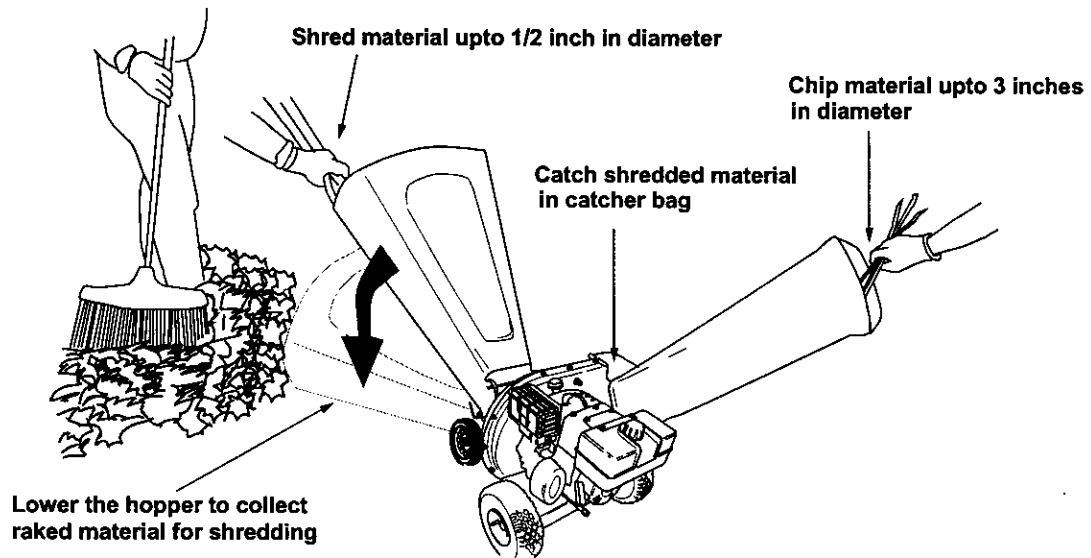

Figure 12

MAINTENANCE

GENERAL RECOMMENDATIONS

- Always observe safety rules when performing any maintenance.
- The warranty on this chipper shredder does not cover items that have been subjected to operator abuse or negligence. To receive full value from the warranty, operator must maintain the chipper-shredder as instructed in this manual.
- Some adjustments will need to be made periodically to maintain your unit properly.
- All adjustments in the Service and Adjustments section of this manual should be checked at least once each season.
- Follow the maintenance schedule given below.
- Periodically check all fasteners and make sure these are tight.



WARNING: Always stop the engine and disconnect the spark plug wire before performing any maintenance or adjustments. **Never remove discharge chute** till the engine has completely stopped.

CLEANING

- Clean the chipper-shredder by running water from a hose through the hopper assembly and chipper chute with the engine running. Allow the chipper-shredder to dry thoroughly.
- Wash the bag periodically with water. Allow to dry thoroughly in the shade. Do not use heat.

ENGINE MAINTENANCE

Engine Oil

- Only use high quality detergent oil rated with API service classification SF, SG or SH. Select the oil's viscosity grade according to your expected

CUSTOMER RESPONSIBILITIES

MAINTENANCE SCHEDULE		SERVICE DATES						SERVICE DATES					
		Before each use	After each use	First five hours	Every 25 hours	Every 50 hours	Before storage						
PRODUCT	Oil pivot points						✓						
	Clean shredder		✓				✓						
ENGINE	Check engine oil	✓											
	Change engine oil			✓	✓								
	Service air cleaner				✓								
	Clean engine				✓		✓						
	Reset spark plug				✓		✓						
	Clean muffler					✓							

operating temperature. Refer to page 9 of this manual for viscosity chart.

- The four-cycle engine of your chipper-shredder will normally consume some oil. Therefore, check engine oil level regularly approximately every five hours of operation and before each usage.
- Stop engine and wait several minutes before checking oil level. With engine on level ground, the oil must be to FULL mark on dipstick.
- Change engine oil after the first five hours of operation, and every twenty-five hours thereafter.

To Drain Oil

Drain oil while engine is warm. Follow the instructions given below.

- Remove oil drain plug. Catch oil in a suitable container.
- When engine is drained of all oil, replace drain plug securely.
- Refill with fresh oil. Refer to GAS AND OIL FILL-UP section.
- Replace dipstick.

Air Cleaner

The air cleaner prevents damaging dirt, dust, etc., from entering the carburetor and being forced into the engine and is important to engine life and performance. The air cleaner consists of a pre-cleaner or foam filter, and a paper filter.

Never run the engine without air cleaner completely assembled.

To Service Air Cleaner:

1. Service pre-cleaner after every 25 hours of use, or at least once a season.
2. Service filter every 100 hours of use, or at least once a season.
3. Service pre-cleaner and filter more often under dusty conditions.
 - Remove wing nut and cover.
 - Slide pre-cleaner off filter. Clean the inside of base and cover thoroughly.
 - Clean pre-cleaner as follows: (See figure 13.)
 - a. Wash in water and detergent solution, and squeeze (don't twist) until all dirt is removed.
 - b. Rinse thoroughly in clear water.
 - c. Wrap in a clean cloth and squeeze (do not twist) until completely dry, or allow to air dry.
 - d. Saturate with engine oil and squeeze (don't twist) to distribute oil and remove excess oil.

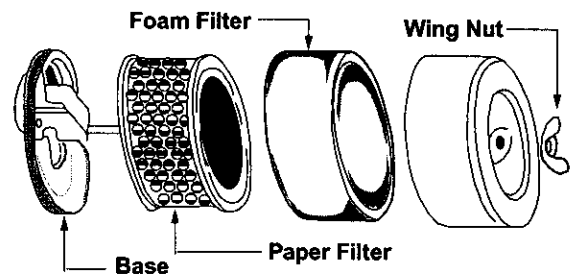

Figure 13

NOTE: If the pre-cleaner is torn or damaged in any way, replace it.

- If necessary, replace paper filter (do not attempt to clean). Install new filter on base.
- Slide pre-cleaner over filter.
- Install cover and wing nut.
- Tighten wing nut securely.

Clean Engine

- Clean engine periodically. Remove dirt and debris with a cloth or brush.
- Frequently remove grass clippings, dirt and debris from cooling fins, air intake screen and levers and linkage. See figure 14. This will help ensure adequate cooling and correct engine speed.

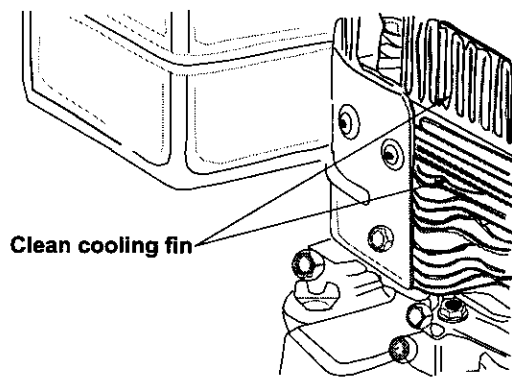

Figure 14

- Yearly or every 25 hours, whichever occurs first, remove the blower housing and clean the areas shown in figure 14 to avoid overspeeding, overheating and engine damage. Clean more often if necessary.

NOTE: Cleaning with a forceful spray of water is not recommended as water could contaminate the fuel system.



WARNING: Temperature of muffler and nearby areas may exceed 150° F(65°C). Avoid these areas.

Spark Plug

- Clean the spark plug and reset the gap to .030" at least once a season or every 50 hours of operation. See figure 15. Spark plug replacement is recommended at the start of each season. Refer to engine parts list for correct spark plug type.

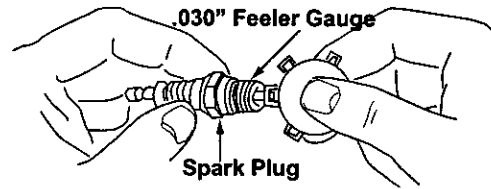

Figure 15

NOTE: Do not sandblast spark plug. Spark plug should be cleaned by scraping or wire brushing and washing with a commercial solvent.

Muffler



WARNING: Do not operate the chipper-shredder **without a muffler**, or tamper with the exhaust system. Damaged mufflers or spark arresters could create a fire hazard.

- Inspect periodically, and replace if necessary. If your engine is equipped with a spark arrester screen assembly, remove every 50 hours for cleaning and inspection. Replace if damaged.



WARNING: Always **stop engine**, **disconnect spark plug wire**, and move it away from spark plug before performing any adjustments or repairs.

LUBRICATION

Lubricate the pivot points on the release bar, hopper assembly, chute deflector and chipper chute once a season using a light oil. See figure 16

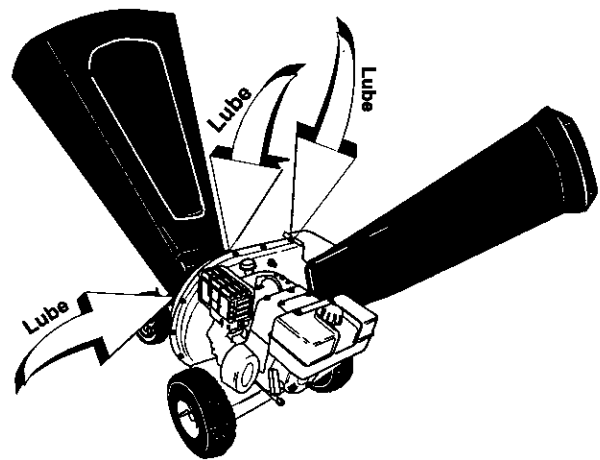

Figure 16: Lubrication Chart

SERVICE & ADJUSTMENTS

REMOVING THE FLAIL SCREEN

If the discharge area becomes clogged, remove the flail screen and clean area as follows.

- Stop engine, make certain the chipper-shredder has come to a complete stop and disconnect spark plug wire from the spark plug before unclogging the chute.
- Remove the two hand knobs on each side of the discharge chute (also called the chute deflector).
- Lift the discharge chute up, and keep it out of the way.
- Remove two hairpin clips from the clevis pins which extend through the housing. Remove the clevis pins. See figure 17.
- Pull the flail screen from inside the housing. See figure 17.
- Clean the screen by scraping or washing with water.
- Reinstall the screen.
- Put the discharge chute back to its original position and tighten the hand knobs.

NOTE: Be certain to reassemble the flail screen with the curved side down.

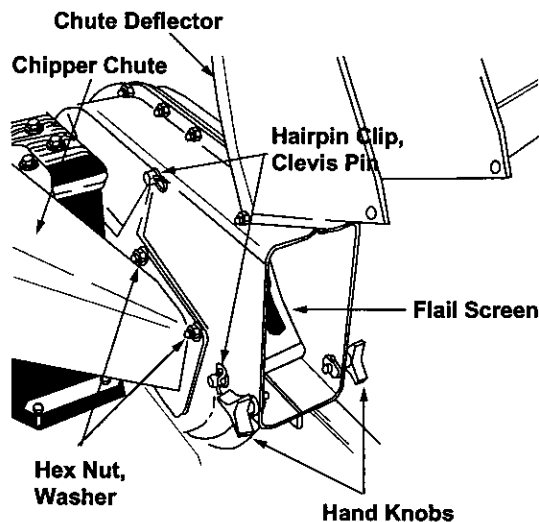

Figure 17

SHARPENING OR REPLACING THE BLADES

Chipper Blades

- Disconnect spark plug wire and move it away from spark plug.

- Remove the flail screen as instructed in previous section.
- Using a 1/2" wrench, remove the chipper chute by removing three hex nuts and washers. See figure 17.
- Using a 7/16" wrench, remove the brace (holding the chute to the frame) by removing the hex bolts.

NOTE: When re-assembling, the cupped washer goes on the slot toward the bottom of the chipper chute with the cupped side against the chute.

- Rotate the impeller assembly by hand until you locate one of the two chipper blades in the chipper chute opening. Remove the blade, using a 3/16" allen wrench on the outside of the blade and 1/2" wrench on the impeller assembly (inside the housing). See figure 18.

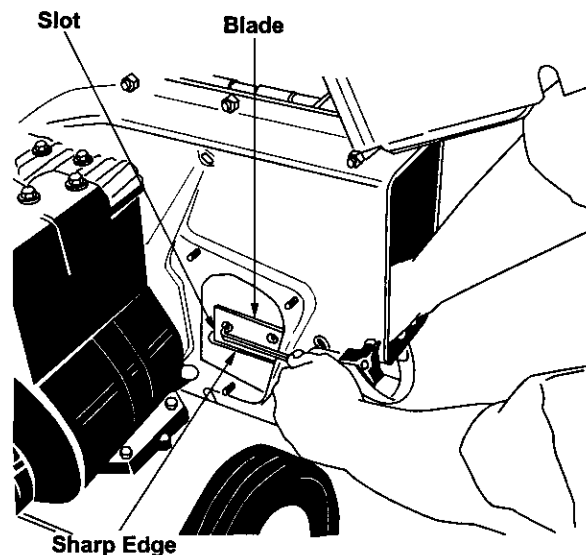

Figure 18

- Remove the other blade in the same manner.
- Replace or sharpen blades.
- If sharpening, make certain to remove an equal amount from each blade.
- Reassemble in reverse order. Make certain blades are reassembled with the sharp edge facing the direction shown in figure 18 (sharp edge is assembled toward the slotted opening at the bottom).
- Torque bolts and nuts to 250-350 inch-pounds.

Shredding Blade

The shredding blade may be removed for sharpening or replacement as follows.

- Disconnect spark plug wire and move it away from spark plug.
- Lower the hopper assembly. Block up the housing. See figure 19.

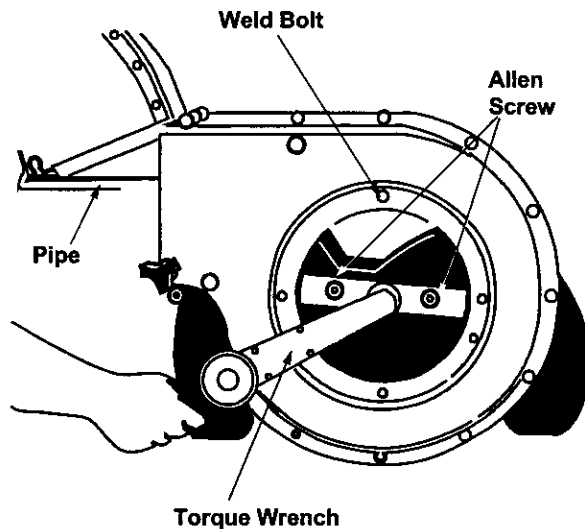

Figure 19

- Remove the six hex lock nuts and lock washers from the housing weld bolts using a 1/2" wrench. Separate the chipper-shredder into two halves.
- Remove the back-up plate.

NOTE: When reassembling, make certain the embossed tab faces inward towards the impeller, and opening on the back-up plate is toward the bottom of the unit.

- Remove the two hand knobs and cupped washers which secure the chute deflector. Raise the chute deflector.
- Insert a 1/2" or 3/4" diameter pipe through the flail screen into the impeller to keep it from turning, or remove the flail screen and insert a piece of wood (2 x 4) into the chute opening.
- Remove the two outside screws on the blade, using a 3/16" allen wrench and a 1/2" wrench.
- Remove the blade by removing the center bolt, lock washer and flat washer.

WARNING: Use caution when removing the blade to avoid contacting the weld bolts on the housing.

- When sharpening the blade, follow the original angle of grind as a guide. It is extremely important that each cutting edge receives an equal amount of grinding to prevent an unbalanced blade.
- An unbalanced blade will cause excessive vibration when rotating at high speeds and may

cause damage to the unit. The blade can be tested for balance by balancing it on a round shaft screwdriver or nail. Remove metal from the heavy side until it is balanced evenly. See figure 20.

- When reassembling the blade, tighten center bolt to between 550 and 650 inch-pounds and the two outer bolts to between 250 and 350 inch-pounds, or lacking torque wrench, tighten securely.

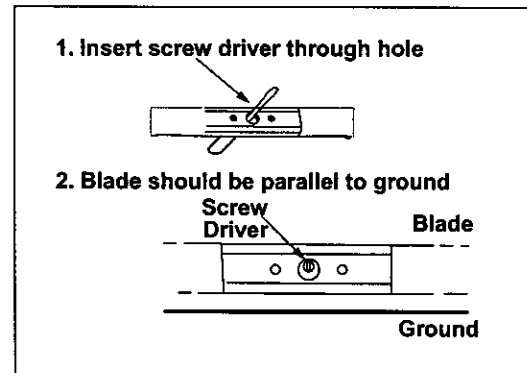

Figure 20

ADJUSTING CARBURETOR



WARNING: If any adjustments are made to the engine while the engine is running (e.g. carburetor), keep clear of all moving parts. Be careful of heated surfaces and muffler.

The carburetor has been pre-set at the factory and should not require adjustment. However, if your engine does not operate properly due to suspected carburetor problems, take your chipper-shredder to your nearest SEARS service center.

ENGINE SPEED

The engine speed on your chipper-shredder has been set at the factory. Do not attempt to increase engine speed or it may result in personal injury. If you believe the engine is running too fast or too slow, take your chipper-shredder to the nearest SEARS service center for repair and adjustment.

TIRES

Recommended operating tire pressure is 24 p.s.i. (sidewall of tire may give tire manufacturers recommended pressure). Equal tire pressure should be maintained on both tires.



WARNING: Excessive pressure when seating beads may cause tire/rim assembly to burst with force sufficient to cause serious injury.

OFF-SEASON STORAGE

Prepare your chipper-shredder for storage at the end of the season or if the unit will not be used for 30 days or more.



WARNING: Never store machine with fuel in the fuel tank inside of building where fumes may reach an open flame or spark, or where ignition sources are present such as hot water and space heaters, furnaces, clothes dryers, stoves, electric motors, etc.

A yearly check-up by your local Sears service center is a good way to make certain your chipper-shredder will provide maximum performance for the next season.

CHIPPER-SHREDDER

- Clean the chipper-shredder thoroughly.
- Wipe unit with an oiled rag to prevent rust (use a light oil or silicone).

ENGINE

IMPORTANT: It is important to prevent gum deposits from forming in essential fuel system parts such as carburetor, fuel filter, fuel hose, or tank during storage. Also, experience indicates that alcohol blended fuels (called gasohol or using ethanol or methanol) can attract moisture which leads to separation and formation of acids during storage. Acidic gas can damage the fuel system of an engine while in storage.

- Drain the fuel tank.
- Start the engine and let it run until the fuel lines and carburetor are empty.
- Drain carburetor by pressing upward on bowl drain which is located below the carburetor.
- Never use engine or carburetor cleaner

products in the fuel tank or permanent damage may occur.

- Use fresh fuel next season.

NOTE: Fuel stabilizer is an acceptable alternative in minimizing the formation of fuel gum deposits during storage.

- Add stabilizer to gasoline in fuel tank or storage container.
- Always follow the mix ratio found on stabilizer container.
- Run engine at least 10 minutes after adding stabilizer to allow the stabilizer to reach the carburetor.
- Do not drain the gas tank and carburetor if using fuel stabilizer. Drain all the oil from the crankcase (this should be done after the engine has been operated and is still warm) and refill the crankcase with fresh oil.
- If you have drained the fuel tank, protect the inside of the engine as follows.
- Remove spark plug, pour approximately 1/2 ounce (approximately one tablespoon) of engine oil into cylinder and crank slowly to distribute oil.
- Replace spark plug.

OTHER

- Do not store gasoline from one season to another.
- Replace your gasoline can if your can starts to rust. Rust and/or dirt in your gasoline will cause problems. Store unit in a clean, dry area. Do not store next to corrosive materials, such as fertilizer.

NOTE: If storing in an unventilated or metal storage shed, be certain to rustproof the equipment by coating with a light oil or silicone.

TROUBLE-SHOOTING

PROBLEM	POSSIBLE CAUSE	CORRECTIVE ACTION
Engine fails to start	<ol style="list-style-type: none"> 1. Fuel tank empty, or stale fuel 2. Spark plug wire disconnected 3. Faulty spark plug 4. Throttle control not in correct position 	<ol style="list-style-type: none"> 1. Fill tank with clean, fresh fuel 2. Connect wire to spark plug. 3. Clean, adjust gap or replace. 4. Move throttle control to FAST position
Loss of power; operation erratic	<ol style="list-style-type: none"> 1. Spark plug wire loose 2. Unit running on Choke 3. Blocked fuel line or stale fuel 4. Water or dirt in fuel system 5. Carburetor out of adjustment 6. Dirty air cleaner 	<ol style="list-style-type: none"> 1. Connect and tighten spark plug wire 2. Move choke lever to OFF position 3. Clean fuel line; fill tank with clean, fresh gasoline. 4. Disconnect fuel line at carburetor to drain fuel tank. Refill with fresh fuel. 5. Contact your SEARS service center. 6. Service air cleaner.
Engine overheats	<ol style="list-style-type: none"> 1. Carburetor not adjusted properly 2. Engine oil level low 	<ol style="list-style-type: none"> 1. Contact your SEARS service center 2. Fill crankcase with proper oil
Too much vibration	<ol style="list-style-type: none"> 1. Loose parts or damaged impeller 	<ol style="list-style-type: none"> 1. Stop engine immediately and disconnect spark plug wire. Tighten all bolts and nuts. Make all necessary repairs. If vibration continues, have unit serviced by a SEARS service center.
Unit does not discharge	<ol style="list-style-type: none"> 1. Discharge chute clogged 2. Foreign object lodged in impeller 	<ol style="list-style-type: none"> 1. Stop engine immediately and disconnect spark plug wire. clean flail screen and inside of blower housing. 2. Stop engine immediately and disconnect spark plug wire. Remove lodged object.
Rate of discharge slows considerably or composition of discharged material changes	<ol style="list-style-type: none"> 1. Shredding blade and/or chipping blade dull 	<ol style="list-style-type: none"> 1. Sharpen or replace blade(s)



For repairs beyond the minor adjustments listed above, please contact your nearest SEARS service center.

PARTS LIST

SEARS CRAFTSMAN 8.5 H.P. CHIPPER-SHREDDER MODEL 247.775880

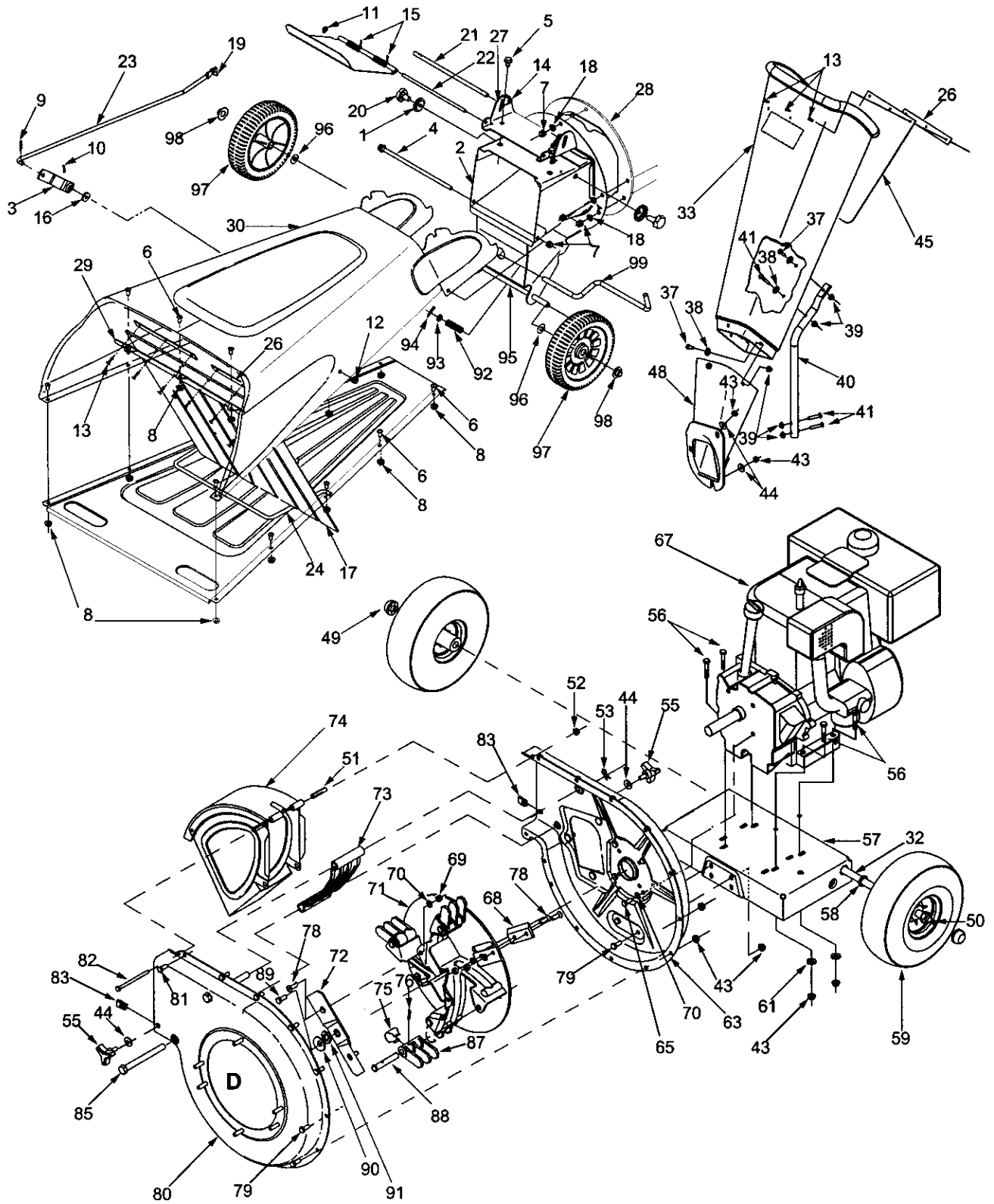

Key No	Part No	Description	Key No	Part No	Description
—	770-1228A	Owner's Manual	49	726-0214	Push Cap 5/8" dia.
1	11480	Stop Washer	50	734-0255	Air Valve
2	681-0118	Inlet Guide Assembly	51	750-0793	Chute Hinge Spacer
3	681-0144	Arm Bracket Assembly	52	712-3027	Hex Ctr. Lock Nut 1/4-20 Thd.
4	710-0542	Hex Flange Bolt: 5/16-18 x 8.375" (Gr.5)	53	714-0149B	Internal Cotter Pin
5	710-0607	Hex Washer Head Self-Tapping Screw: 5/16-18 x 0.5"	55	720-0170	Hand Knob
6	710-3256	Button-Head Screw 1/4-20 x 0.5"	56	710-0805	Hex Bolt 5/16-18 x 1.5"
7	712-0429	Lock Nut: 5/16-18	57	781-0510B	Shredder Frame
8	712-3027	Hex Flange Lock Nut: 1/4-20	58	736-0366	Flat Washer 1.12 x .64 x .120
9	714-0104	Internal Cotter Pin	59	734-1845	Wheel Assembly
10	715-0129	Spiral Pin	61	736-0170	Special Lock Washer
11	726-0106	Cap Nut	63	681-0117-0689	Flail Housing Ass'y. — Inner
12	726-0135	Speed Cap Nut	65	710-0157	Hex Bolt 5/16-24 x .75" Lg.
13	728-0175	Pop Rivet	67	—	Engine, Tecumseh 143.988503
14	732-0546	Torsion Spring	68	781-0490	Chipper Blade
15	732-0629	Hopper Door Spring	69	712-0411	Hex Top Lock Nut 5/16-24 (Gr. 5)
16	735-0127	Rubber Washer	70	736-0119	Lock Washer 5/16" I.d.
17	735-0651	Hopper Flap	71	681-0030	Impeller assembly
18	736-0119	Lock Washer	72	742-0571	Shredder Blade
19	738-0137A	Shdr. Scr: .340 x .285 x 1/4-20	73	781-0457-0637	Shredder Screen
20	738-0946	Shdr. Scr: .56 x .165 x 5/16-18	74	681-0094	Discharge Chute Assembly
21	747-0531A	Rel. Rod: 5/16" dia.	75	781-0735	Retaining Clip
22	747-0747	Hopper Door Rod	76	715-0166	Spring Roll Pin
23	747-1124	Flap Retaining Rod	78	710-1054	Flat Head Scr. 5/16-24 x .75"
24	747-1125	Flap Retaining Bail	79	710-3008	Hex Bolt 5/16-18 x .75" (Gr. 5)
25	781-0492A	Hopper Pivot Door	80	681-0004A-0689	Flail Housing Ass'y. — Outer
26	781-0633	Chute Flap Strip	82	710-0825	Hex Bolt 1/4-20 x 3.75"
27	781-0698	Hopper Lock Bracket	83	726-0211	U Nut 5/16-18
28	781-0715	Shredder Plate	85	711-0835	Clevis Pin
29	781-0752	Flap Mounting Bracket	87	719-0329	Flail Blade
30	781-0754-0689	Upper Hopper	88	711-0833B	Clevis Pin
31	781-0755-0689	Lower Hopper	89	710-1254	Hex Patch Bolt 3/8-24 x 2.25" (Gr. 8)
32	738-0813	Shredder Axle	90	736-0217	Lock Washer 3/8"
33	731-1899	Chipper Chute	91	736-0247	Flat Washer .406" I.d. x 1.25"
37	710-0751	Hex Bolt 1/4-20 x .625	92	732-0306	Compression Spring
38	736-0173	Flat Washer .28 I.d. x .74 O.d.	93	736-0117	Flat Washer
39	712-3027	Flanged Lock Nut	94	714-0104	Internal Cotter Pin
40	749-1004	Chipper Chute Support	95	711-1304	Axle Shaft
41	710-0106	Hex Scr. 1/4-20 x .625 (Gr. 2)	96	736-0160	Flat Washer
43	712-3010	Hex Nut 5/16-18 Thd. (Gr. 5)	97	734-1797	Complete Wheel: Grey
44	736-0242	Bell Washer .345" I.d. x .88"	98	726-0299	Push Cap
45	735-0249	Shredder Chute Flap	99	747-0982	Lock Rod
48	681-0068-0689	Chipper Chute Assembly	100	764-0501	Shredder Bag

**SEARS CRAFTSMAN 8.5 H.P. ENGINE MODEL 143.988503 FOR
CHIPPER-SHREDDER MODEL 247.775880**

Key No.	Part No.	Description	Key No.	Part No.	Description
—	—	RPM Low 1700	80	31845	Governor Shaft
—	—	RPM High 3450 to 3750	81	30590A	Washer
1	35385	Cylinder (Incl. 2 & 20)	82	35378	Governor Gear Ass'y.
2	27652	Dowel Pin	83	30588A	Governor Spool
4	—	Oil Drain Extension	84	29193	Retaining Ring
5	30969	Extension Cap	86	650833	Screw, 1/4-20 x 1-3/16"
15	30699C	Governor Rod (Incl. 15A & 15B)	87	650832	Screw, 1/4-20 x 1-11/16"
15A	30700	Governor Yoke	89	32589	Flywheel Key
15B	650494	Screw, 6-40 x 5/16"	90	611090	Flywheel
16	33454	Governor Lever	92	650880	Lock Washer
17	29916	Governor Lever Clamp	93	650881	Flywheel Nut
18	651028	Screw, Torx T-15, 8-32 x 3/8"	100	35135	Solid State Ignition
19	34663	Speed Control Spring	101	610118	Spark Plug Cover
20	35319	Oil Seal	102	651024	Solid State Mounting Stud
25	36460	Blower Housing Baffle	103	651007	Screw, Torx T-15, 10-24 x 15/16"
26	650561	Screw, 1/4-20 x 5/8"	110	35187	Ground Wire
28	30322	Lock Nut, 8-32	119	36448	Cylinder Head Gasket
30	36283A	Crankshaft	120	36449	Cylinder Head
35	29826	Screw, 10-32 x 3/4"	125	27878A	Exhaust Valve (std.)
36	29918	Lock Washer	125	27880A	Exhaust Valve (1/32" os)
37	29216	Lock Nut, 10-32	126	34035	Intake Valve (std.)
38	29642	Retaining Ring	126	34036	Intake Valve (1/32" os)
40	40011	Piston, Pin & Ring Set (std.)	127	650691	Washer
40	40012	Piston, Pin & Ring Set (.010" os)	128	650690	Belleville Washer
41	40009	Piston & Pin Assembly (std.)	130	650694A	Screw, 5/16-18 x 2"
41	40010	Piston & Pin Assembly (.010" os)	130A	650273	Screw, 5/16-18 x 5/8"
42	40013	Ring Set (std.)	130B	651031	Screw, 1/4-20 x 9/16"
42	40014	Ring Set (.010" os)	135	33636	Resistor Spark Plug
43	27888	Piston Pin Retaining Ring	139	33369	Governor Gear Bracket
45	36897	Connecting Rod Ass'y (incl. 47 & 49)	140	650836	Screw, 10-24 x 1/2"
47	651033	Connecting Rod Bolt	149	27882	Valve Spring Cap
48	34034	Valve Lifter	149A	35862	Valve Spring Cap
49	36896	Oil Dipper	150	27881	Valve Spring
50	35375	Camshaft (MCR)	151	32581	Valve Spring Keeper
60	33273A	Blower Housing Extension	169	27896A	Breather Gasket
65	650128	Screw, 10-24 x 1/2"	170	28423	Breather Body
69	35262A	Cylinder Cover Gasket	171	28424	Breather Element
70	35376	Cylinder Cover (Incl. 71, 75 & 80)	172	28425	Valve Cover
71	35377	Crankshaft Bushing	173	36675A	Breather Tube
72	28582	Oil Drain Plug	173A	32446	Breather Tube Grommet
75	35319	Oil Seal	174	650128	Screw, 10-24 x 1/2"
			178	29752	Nut & Lock Washer
			182	30088A	Screw, 1/4-28 x 1"
			184	33263	Carburetor to Intake Pipe Gasket

**SEARS CRAFTSMAN 8.5 H.P. ENGINE MODEL 143. 988503 FOR
CHIPPER-SHREDDER MODEL 247.775880**

Key No.	Part No.	Description	Key No.	Part No.	Description
185	34707	Intake Pipe	278	36908	Heat Shield Spacer
186	34667	Governor Link	280	36799A	Heat Shield
200	34677	Control Bracket (Incl. 19, 203 & 204)	281	33013	Starter Bubble Cover
203	31342	Compression Spring	282	650760	Screw, 8-32 x 3/8"
204	651029	Screw, Torx T-10, 5-40 x 7/16"	285	35985B	Starter Cup
206	610973	Terminal	287	29752	Nut & Lock Washer
207	33878	Throttle Link	290	30962	Fuel Line
209	650821	Screw, 10-32 x 1/2"	292	26460	Fuel Line Clamp
215	35882	Control Knob	298	650665	Screw, 1/4-15 x 3/4"
223	650378	Screw, Torx T-30, 5/16-18 x 1-1/8	300	34186A	Fuel Tank
224	27915A	Intake Pipe Gasket	301	36246	Fuel Cap
238	28820	Screw, 10-32 x 1/2"	305	35554	Oil Fill Tube
239	27272A	Air Cleaner Gasket	307	35499	O Ring
240	37104	Air Cleaner Bracket	308	35540	Fill Tube Clip
242	33267	Air Cleaner Bracket	310	36205	Dipstick
245	33268	Air Cleaner Filter	325	29443	Wire Clip
245A	35881	Air Cleaner Filter	327	35392	Starter Plug
250	33269A	Air Cleaner Cover	339	35880	Spacer
251	650513	Wing Nut, 1/4-20	340	34259	Fuel Tank Bracket
260	36250	Blower Housing	341	34258A	Fuel Tank Bracket
261	650788	Screw, 5/16-18 x 3/4"	342	30063	Screw, Torx T-30, 1/4-20 x 1/2"
262	29747B	Screw, Torx T-40, 5/16-24 x 21/32"	370G	35274	Oil Instruction Decal
264A	650802	Screw, 1/4-20 x 5/8"	370J	35703	Throttle Decal
265	33272B	Cylinder Head cover	380	640112	Carburetor (Incl. 184)
275	34185B	Muffler	390	590746	Rewind Starter
276	31588	Locking Plate	400	36450B	Gasket Set
277	650729	Screw, 5/16-18 x 3-3/16"	416	34479A	Spark arrester Kit
277A	651036	Screw, 5/16-18 x 3-31/32"	900	—	Replacement Engine none
			900	—	Replacement SB 756321, Order 71-999

SEARS CRAFTSMAN 8.5 H.P. ENGINE MODEL 143.988503 FOR CHIPPER-SHREDDER MODEL 247.775880

Carburetor

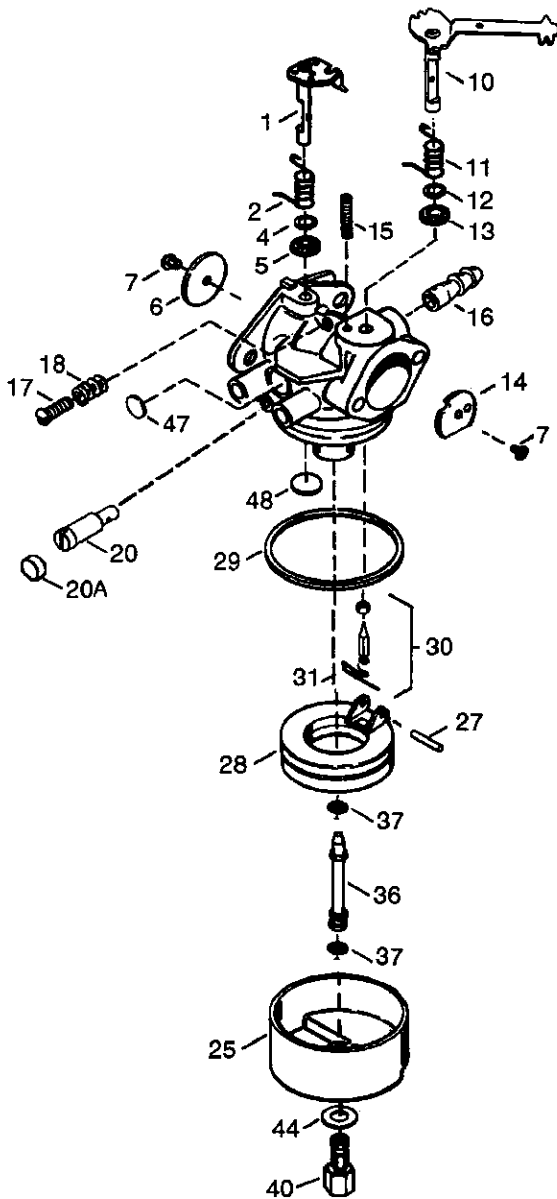

Key No.	Part No.	Description
	640112	Carburetor (Incl. 184 of Engine Parts List)
1	631776A	Throttle Shaft & Lever Assembly
2	631970	Throttle Return Spring
4	631184	Dust Seal Washer
5	631183	Dust Seal (Throttle)
6	640109	Throttle Shutter
7	650506	Shutter Screw
10	632740	Choke Shaft & Lever Assembly
11	632043	Choke Return Spring
12	631184	Dust Seal Washer
13	631183	Dust Seal (Choke)
14	631753	Choke Shutter
15	630735	Choke Positioning Spring
16	632164	Fuel Fitting
17	651025	Throttle Crack Screw/Idle Speed Screw
18	630766	Tension Spring
20	640027	Idle Mixture Screw
20A	640053	Idle Restrictor Screw
25	631867	Float Bowl
27	631024	Float Shaft
28	632019	Float
29	631028	Float Bowl "O"-Ring
30	631021	Inlet Needle, Seat & Clip (Incl. 31)
31	631022	Spring Clip
36	640113	Main Nozzle Tube
37	632547	O Ring, Main Nozzle Tube
40	640114	High Speed Bowl Nut
44	27110	Bowl Nut Washer
47	630748	Welch Plug, Idle Mixture Well
48	631027	Welch Plug, Atmospheric Vent

SEARS CRAFTSMAN 8.5 H.P. ENGINE MODEL 143.988503 FOR CHIPPER-SHREDDER MODEL 247.775880

Recoil Starter 590746

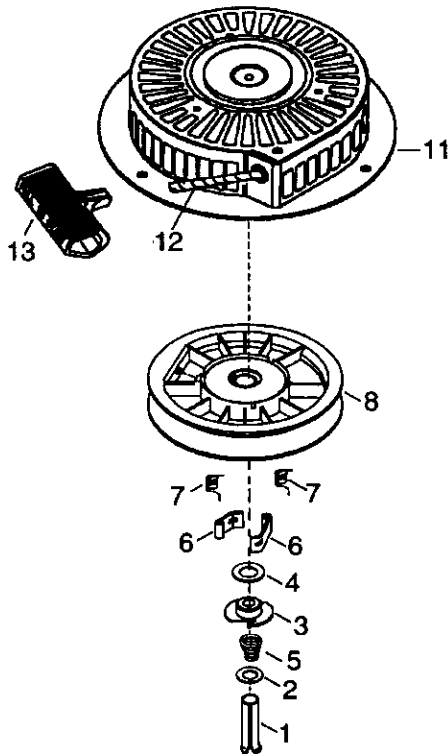

Key No.	Part No.	Description
	590746	Recoil Starter
1	590599A	Spring Pin (Incl. 4)
2	590600	Washer
3	590679	Retainer
4	590601	Washer
5	590678	Brake Spring
6	590680	Starter Dog
7	590412	Dog Spring
8	590681	Pulley & Rewind Spring Ass'y
11	590747	Starter Housing Ass'y
12	590535	Starter Rope (98" x 9/64" Dia.)
13	590701	Starter Handle

**For the repair or replacement parts you need
delivered directly to your home**

Call 7 am - 7 pm, 7 days a week

1-800-366-PART

(1-800-366-7278)

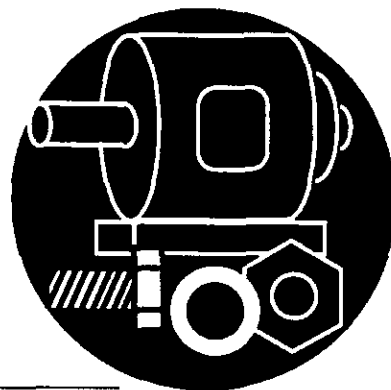

For in-home major brand repair service

Call 24 hours a day, 7 days a week

1-800-4-REPAIR

(1-800-473-7247)



**For the location of a
Sears Parts and Repair Center in your area**

Call 24 hours a day, 7 days a week

1-800-488-1222



**For information on purchasing a Sears
Maintenance Agreement or to inquire
about an existing Agreement**

call 9 am - 5 pm, Monday-Saturday

1-800-827-6655



SEARS
REPAIR SERVICES
America's Repair Specialists

Free Manuals Download Website

<http://myh66.com>

<http://usermanuals.us>

<http://www.somanuals.com>

<http://www.4manuals.cc>

<http://www.manual-lib.com>

<http://www.404manual.com>

<http://www.luxmanual.com>

<http://aubethermostatmanual.com>

Golf course search by state

<http://golfingnear.com>

Email search by domain

<http://emailbydomain.com>

Auto manuals search

<http://auto.somanuals.com>

TV manuals search

<http://tv.somanuals.com>