

SEARS OWNER'S MANUAL

**MODEL NOS.
247.797852
247.797853**

**Caution:
Read and Follow
All Safety Rules
and Instructions
Before Operating
This Equipment**

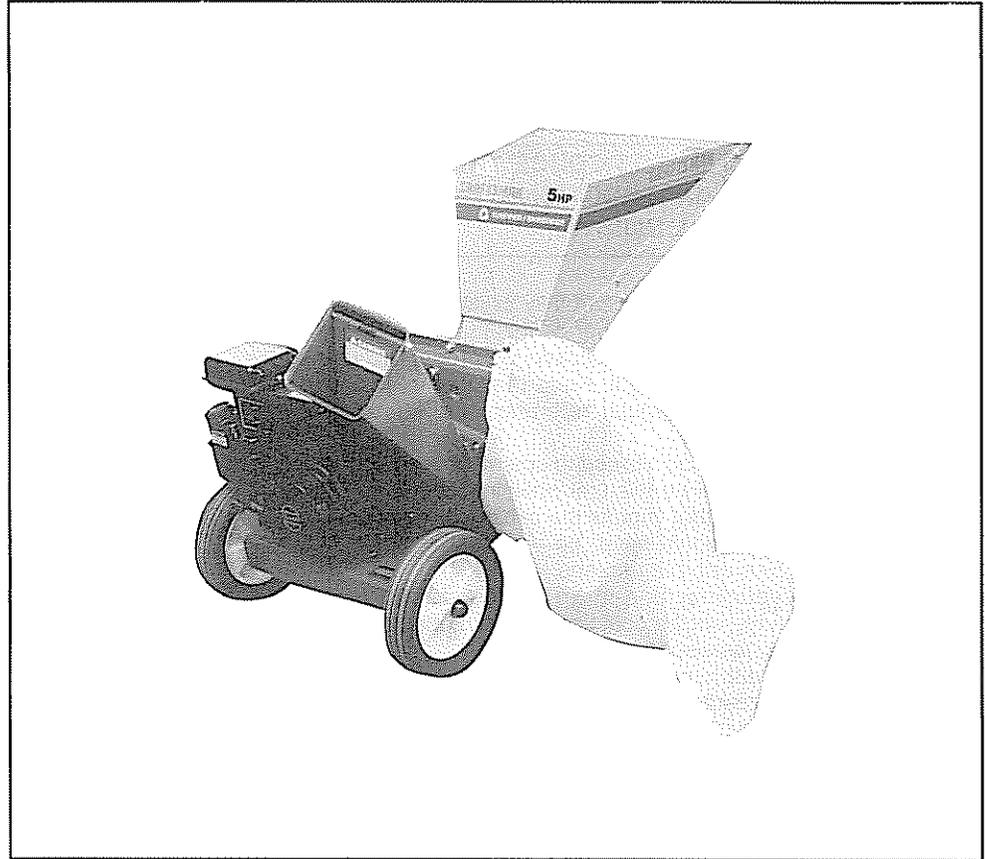

CRAFTSMAN®

**5 HORSEPOWER
3 CUTTING STAGE
MULCHING AND BAGGING
CHIPPER-SHREDDER**

**Assembly
Operation
Maintenance
Service and Adjustment
Repair Parts**

SEARS, ROEBUCK AND CO., Chicago, IL 60684 U.S.A.

SAFETY RULES



WARNING: TO REDUCE THE POTENTIAL FOR ANY INJURY, COMPLY WITH THE FOLLOWING SAFETY INSTRUCTIONS. FAILURE TO COMPLY WITH THE INSTRUCTIONS MAY RESULT IN PERSONAL INJURY.

TRAINING

- Read this owner's manual carefully in its entirety before attempting to assemble or operate this machine. Be completely familiar with the controls and the proper use of this machine before operating it. Keep this manual in a safe place for future and regular reference and for ordering replacement parts.
- Children must never be allowed to operate this equipment.
- No one should operate this unit while intoxicated or while taking medication that impairs the senses or reactions.
- This equipment should never be operated in the vicinity of children, pets or other persons.
- Never run your machine in an enclosed area as the exhaust from the engine contains carbon monoxide, which is an odorless, tasteless and deadly poisonous gas.
- Never place your hands or any part of your body or clothing inside the feeding chamber, discharge chute, or near any moving part while the machine or engine is running.
- If it is necessary for any reason to inspect or repair the feeding chamber or any part of the machine where a moving part can come in contact with your body or clothing, stop the machine, allow it to cool, disconnect the spark plug wire from the spark plug and move it away from the spark plug before attempting such inspection or repair.

PREPARATION

- Wear safety glasses provided with your unit while operating the chipper-shredder to prevent injury from any material which may be ejected out of the openings.
- Wear proper apparel. Avoid wearing loose fitting clothing. Wear gloves when handling material.
- **HANDLE GASOLINE WITH CARE** as it is an extremely flammable fuel.
- Check the fuel before starting the engine. Do not fill the fuel tank indoors, while the engine is running, or while the engine is still hot. Turn the unit off and let the engine cool before refueling.
- Fuel your chipper-shredder in a clean area. Do not smoke while refueling.
- Fuel tank cap must be secure at all times except during refueling.
- Avoid spilling gasoline or oil. Wipe the unit clean of any spilled fuel or oil.
- Store fuel and oil in approved containers, away from heat or open flame, and out of reach of children.
- This machine should be operated only upon a level surface.
- Assure that all screws, nuts and bolts and other fasteners are properly secured.

OPERATION

- When feeding shreddable material into this equipment, be extremely careful that pieces of metal, rocks, bottles, cans or other foreign objects are not included. Personal injury or damage to the machine could result.

- If the cutting mechanism strikes any foreign object or if your machine should start making an unusual noise or vibration, immediately stop the engine, disconnect the spark plug wire from the spark plug and move it away from the spark plug. Allow the machine to stop and take the following steps:
 - Inspect for damage.
 - Replace or repair any damaged parts.
 - Check for any loose parts and tighten to assure continued safe operation.
- The engine must be kept clean of debris and other accumulations.
- Do not allow an accumulation of processed material to build up in the discharge area as this will prevent proper discharge and can result in kick-back from feed opening.
- Never place your hands or any other part of your body or clothing inside the feeding chamber, discharge chute or near any moving part while the engine is running.
- Keep all guards and deflectors in place and in good working condition to assure continued safe operation.
- Always stand clear of the discharge area when operating this machine.
- Keep your face and body back from the feed opening to avoid accidental bounce back of any material.
- Do not over-reach. Keep proper balance and footing at all times.
- The engine governor settings on your machine must not be altered, changed, or tampered with. The governor controls the maximum safe operating speeds and protects the engine and all moving parts from damage caused by overspeed.
- Do not transport machine while engine is running.
- Do not operate engine if air cleaner or cover directly over carburetor air intake is removed, except for adjustment. Removal of such parts could create a fire hazard.

MAINTENANCE AND STORAGE

- When this equipment is stopped for servicing, inspection, storage or to change an accessory, make sure the spark plug wire is disconnected from the spark plug and moved away from the spark plug. The machine should be allowed to cool down before making such inspection, adjustments, service, etc. Maintain your machine with care and keep it clean for the best and continued safe operation.
- Do not use flammable solutions to clean the air filter.
- When not in use, your machine should be stored out of the reach of children. Keep where gasoline fumes will not reach an open flame or spark. For long periods of storage, refer to the "Storage" section of this manual.



LOOK FOR THIS SYMBOL TO POINT OUT IMPORTANT SAFETY PRECAUTIONS. IT MEANS—ATTENTION!!! BECOME ALERT!!! YOUR SAFETY IS INVOLVED.

CONGRATULATIONS on your purchase of a Sears Craftsman Chipper-Shredder. It has been designed, engineered and manufactured to give you the best possible dependability and performance.

Should you experience any problem you cannot easily remedy, please contact your nearest Sears Service Center/Department. We have competent, well-trained technicians and the proper tools to service or repair this unit.

Please read and retain this manual. The instructions will enable you to assemble and maintain your chipper-shredder properly. Always observe the "SAFETY RULES."

MODEL NUMBER _____
SERIAL NUMBER _____
DATE OF PURCHASE _____
THE MODEL AND SERIAL NUMBERS WILL BE FOUND ON A LABEL ATTACHED TO THE FRAME OF THE CHIPPER-SHREDDER.
YOU SHOULD RECORD BOTH SERIAL NUMBER AND DATE OF PURCHASE AND KEEP IN A SAFE PLACE FOR FUTURE REFERENCE.

PRODUCT SPECIFICATIONS

Horsepower:	5.0
Displacement:	12.57 cu. in.
Fuel Capacity:	3 Quarts
Spark Plug (Gap .030 in.):	Champion J19LM or Equivalent
Magnetron® Ignition Air Gap:	.0125 in.

MAINTENANCE AGREEMENT

A Sears Maintenance Agreement is available on this product. Contact your nearest Sears store for details.

CUSTOMER RESPONSIBILITIES

- Read and observe the safety rules.
- Follow a regular schedule in maintaining, caring for and using your chipper-shredder.
- Follow the instructions under "Maintenance" and "Storage" sections of this Owner's Manual.

WARRANTY

ONE YEAR LIMITED WARRANTY ON CRAFTSMAN GAS CHIPPER-SHREDDER

For one year from the date of purchase, when this Craftsman Chipper-Shredder is maintained, lubricated and tuned up according to the instructions in the owner's manual, Sears will repair, free of charge, any defect in material and workmanship.

If this Craftsman Chipper-Shredder is used for commercial or rental purposes, this warranty applies for only 30 days from the date of purchase.

This warranty does not cover:

- Expendable items which become worn during normal use, such as blades, chipper blades, flails, air cleaners, spark plugs and catcher bags.
- Repairs necessary because of operator abuse or negligence, including bent crankshafts and the failure to maintain the equipment according to the instructions contained in the owner's manual.

WARRANTY SERVICE IS AVAILABLE BY RETURNING THE CRAFTSMAN CHIPPER-SHREDDER TO THE NEAREST SEARS SERVICE CENTER/DEPARTMENT IN THE UNITED STATES. THIS WARRANTY APPLIES ONLY WHILE THIS PRODUCT IS IN USE IN THE UNITED STATES.

This warranty gives you specific legal rights, and you may also have other rights which may vary from state to state.

SEARS, ROEBUCK AND CO., Department 731CR-W, Sears Tower, Chicago, IL 60684

TABLE OF CONTENTS

SAFETY RULES.....	2	STORAGE.....	12
PRODUCT SPECIFICATIONS.....	3	SERVICE AND ADJUSTMENT.....	13-15
CUSTOMER RESPONSIBILITIES.....	3	SERVICE RECOMMENDATIONS.....	15
WARRANTY.....	3	TROUBLE SHOOTING.....	16
INDEX.....	4	REPAIR PARTS—CHIPPER-SHREDDER.....	17, 18
ASSEMBLY.....	5, 6	REPAIR PARTS—ENGINE.....	19-23
OPERATION.....	7-10	PARTS ORDERING/SERVICE.....	Back Cover
MAINTENANCE.....	10, 11		

INDEX

	A		O
Adjustments:		Oil.....	8
Carburetor.....	14	Operating Tips.....	9, 10
Engine Speed.....	15	R	
Assembly Instructions:		Release Bar.....	7
Catcher Bag.....	6	Repair/Replacement Parts.....	17-23
Chute Crank Deflector.....	6	Responsibilities, Customer.....	3
Hopper Assembly.....	6	S	
Catcher Bag.....	6	Safety Rules.....	2
C		Sharpening.....	13, 14
Catcher Bag.....	6	Service Recommendations.....	15
Controls.....	7	Spark Plug.....	11
Customer Responsibilities.....	3	Specifications.....	3
E		Storage.....	12
Engine:		T	
Maintenance.....	10, 11	Table of Contents.....	4
Starting.....	8	Trouble Shooting.....	16
Stopping.....	9	U	
Storage.....	12	Unclogging.....	13
F		Unpacking.....	5
Fuel.....	8	W	
L		Warranty.....	3
Lubrication.....	10		
M			
Maintenance:			
Agreement.....	3		
Engine.....	10, 11		
Chipper-Shredder.....	10		

WARNING: This unit is equipped with an internal combustion engine and should not be used on or near any unimproved forest-covered, brush-covered or grass-covered land unless the engine's exhaust system is equipped with a spark arrester meeting applicable local or state laws (if any). If a spark arrester is used, it should be maintained in effective working order by the operator.

In the State of California the above is required by law (Section 4442 of the California Public Resources Code). Other states may have similar laws. Federal laws apply on federal lands. A spark arrester for the muffler (see page 23) is available through your Sears Authorized Service Center.

ASSEMBLY INSTRUCTIONS

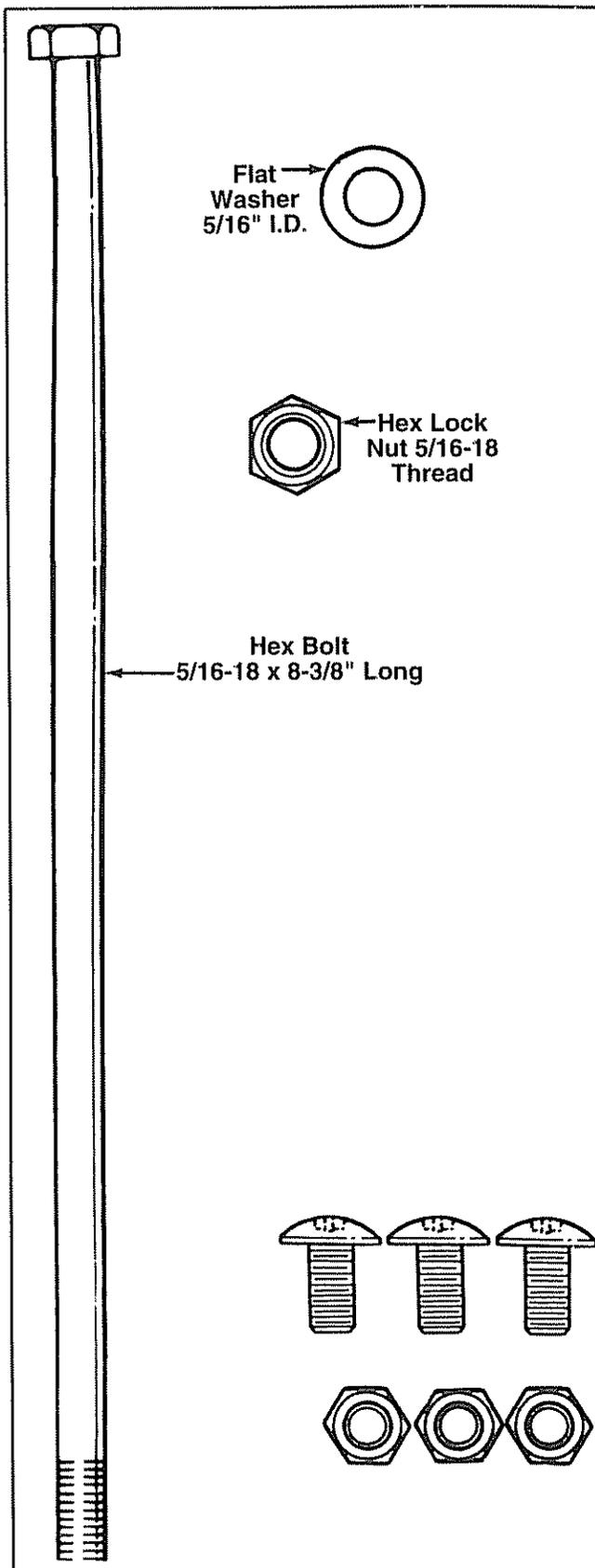

IMPORTANT: This unit is shipped WITHOUT GASOLINE or OIL. After assembly, see operation section of this manual for proper fuel and engine oil recommendations.

NOTE: To determine right and left hand sides of your chipper-shredder, stand behind and face the hopper (engine is at the front of the unit).

Your chipper-shredder has been completely assembled at the factory, except for the hopper assembly (hopper hood and upper leaf ramp section have been sub-assembled), upper guide assembly, chute deflector and the catcher bag. The hardware pack and safety glasses are also included in the carton.

The hardware pack contains the parts shown in figure 1 (shown full size).

TO REMOVE CHIPPER-SHREDDER FROM CARTON

Cut the corners of the carton. Remove all packing inserts. Roll chipper-shredder out of the carton. Make certain all parts and literature have been removed before the carton is discarded.

TOOLS REQUIRED FOR ASSEMBLY

- (1) Phillips Screwdriver
- (2) 1/2" or Adjustable Wrenches
- (2) 7/16" or Adjustable Wrenches

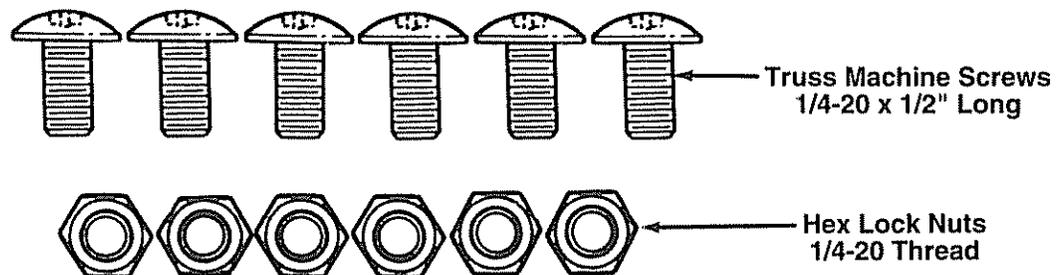

FIGURE 1.

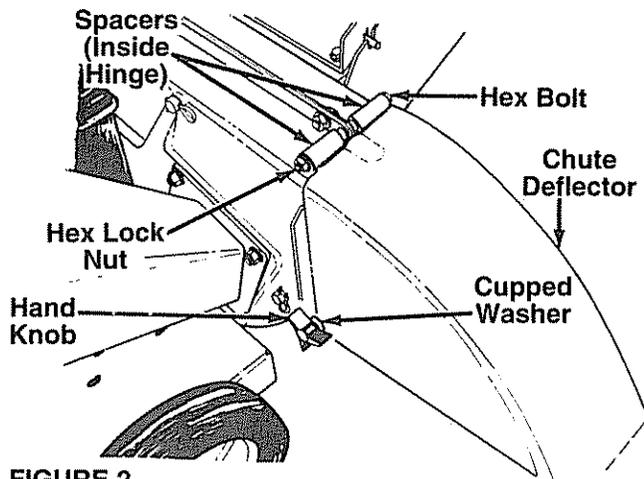

FIGURE 2.

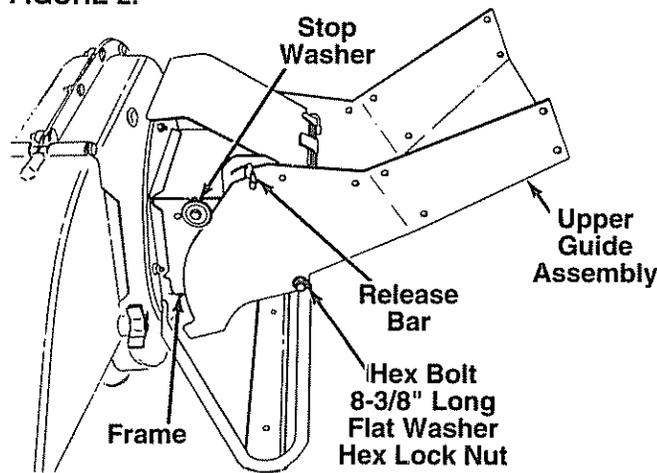

FIGURE 3.

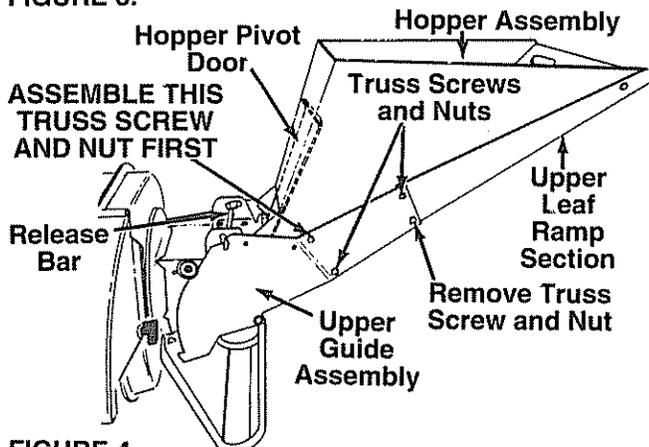

FIGURE 4.

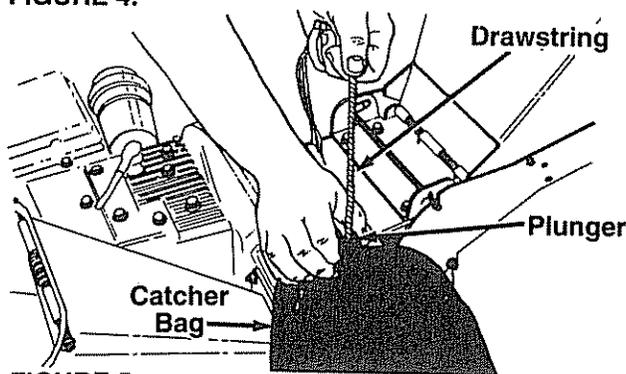

FIGURE 5.

HOW TO SET-UP YOUR CHIPPER-SHREDDER



MAKE CERTAIN THE SPARK PLUG WIRE IS DISCONNECTED AND MOVED AWAY FROM THE SPARK PLUG BEFORE ASSEMBLING THE CHIPPER-SHREDDER.

← ATTACHING THE HOPPER ASSEMBLY

- Remove the hand knobs and cupped washers from each side of the discharge opening on the left side of the chipper-shredder.
- Remove hex lock nut, two spacers and hex bolt from inside the hinge on top of the discharge opening. Do not remove one spacer from the hex bolt.
- Place the chute deflector in position on the discharge opening. Insert hex bolt and spacer through hinge on chute deflector and housing (spacer fits inside of hinge). See figure 2.
- Place second spacer over hex bolt, inside other part of hinge. Secure with hex lock nut. Tighten securely.
- Secure both sides of chute deflector to housing using hand knobs and cupped washers (cupped side of washers go against chute deflector).

← ATTACHING THE UPPER GUIDE ASSEMBLY

Place upper guide assembly in position on frame, making certain edges of the upper guide assembly are underneath stop washers, and the release bar is in the slots. See figure 3. Insert hex bolt 8-3/8" long through upper guide assembly and frame. Secure with flat washer and hex lock nut.

NOTE: Make certain upper guide assembly can pivot by pulling up on release bar and lowering upper guide assembly. If necessary, loosen hex lock nut a turn or two. Put the upper guide assembly back into the raised position.

← ATTACHING THE HOPPER ASSEMBLY

Your chipper-shredder has been shipped with the upper leaf ramp section attached to the hopper assembly. See figure 4. Attach the hopper assembly to the upper guide assembly as follows. Be certain to place heads of all truss machine screws **inside** of hopper assembly.

- Remove one truss machine screw and nut from each side of hopper assembly as shown in figure 4. **Push hopper pivot door down inside lower part of hopper** as you place hopper assembly (both pieces) **inside** upper guide assembly. Replace truss screws and nuts just removed, using the hole shown in figure 4, one on each side. Tighten finger tight only.
- Place the six truss machine screws and nuts found in hardware pack in the remaining holes of hopper assembly, alternating sides of the unit and tightening finger tight only.
- After assembling all eight screws, tighten them securely.

← ATTACHING THE CATCHER BAG

Your chipper-shredder is equipped with a catcher bag to catch the shredded material.

- To attach the bag, place the opening of the bag over the chute deflector so it completely covers the chute opening. Depress the plunger on the draw-

string, and pull on the drawstring until the bag is tight around the chute opening. Release plunger to lock it into position. See figure 5.

OPERATION

KNOW YOUR CHIPPER-SHREDDER

READ THIS OWNER'S MANUAL AND SAFETY RULES BEFORE OPERATING YOUR CHIPPER-SHREDDER. Compare the illustrations with your chipper-shredder to familiarize yourself with the location of various controls and adjustments. Save this manual for future reference.

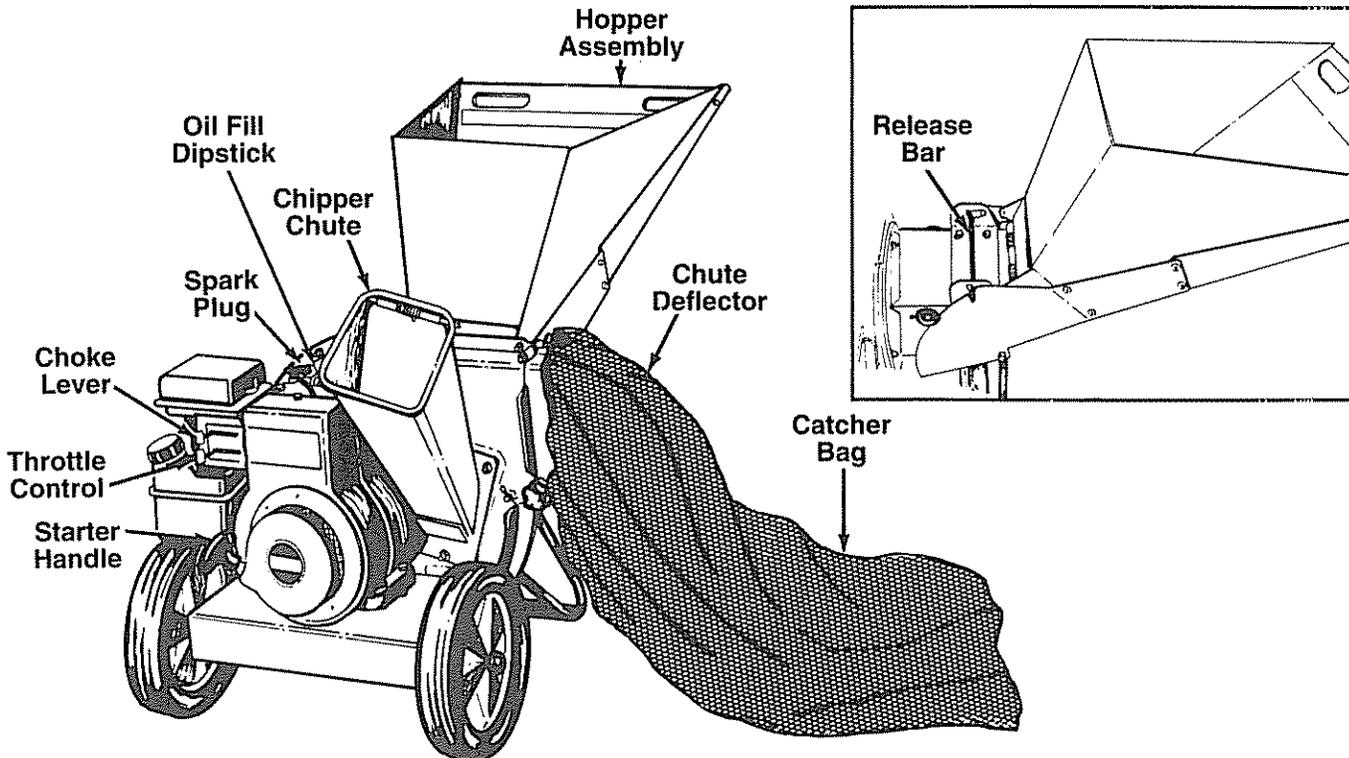

FIGURE 6.

MEETS ANSI SAFETY STANDARDS

Sears chipper-shredders conform to the safety standards of the American National Standards Institute.

OPERATING CONTROLS (See figure 6)

RELEASE BAR—Used to release the hopper when raising or lowering.

CHOKE LEVER—Used to enrich the fuel mixture in the carburetor when starting a cold engine.

STARTER HANDLE—Used to manually start the engine.

THROTTLE CONTROL—Controls engine speed and stops the engine.

BEFORE USING YOUR CHIPPER-SHREDDER, AGAIN REFER TO THE "SAFETY RULES" AS SHOWN ON PAGE 2 OF THIS MANUAL. ALWAYS BE CAREFUL.



The operation of any chipper-shredder can result in foreign objects being thrown into the eyes, which can result in severe eye damage. Always wear the safety glasses provided with the chipper-shredder or eye shields before chipping or shredding, or while performing any adjustments or repairs. We recommend Wide Vision Safety Mask for over spectacles or standard glasses available at Sears Retail or Catalog Stores.

BEFORE STARTING

GAS AND OIL FILL-UP

NOTE: ENGINE IS SHIPPED WITHOUT OIL. FILL CRANKCASE WITH OIL BEFORE STARTING. BE VERY CAREFUL NOT TO ALLOW DIRT TO ENTER THE ENGINE WHEN CHECKING OR ADDING OIL OR FUEL.

Recommended SAE Viscosity Grades

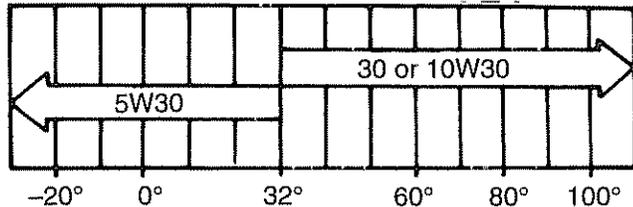

TEMPERATURE RANGE EXPECTED BEFORE NEXT OIL CHANGE. ALL OILS MUST BE A.P.I. SERVICE CLASSIFICATION SD, SE OR SF.

- Fill engine with oil as follows. Remove oil fill dipstick. See figure 7. With chipper-shredder level, use a funnel to fill engine with oil to FULL mark on dipstick. Capacity is approximately 1-1/4 pints. Be careful not to overfill. Tilt chipper-shredder toward the left (from behind the hopper), then re-level. Check oil level. Refill to FULL mark on dipstick if necessary. Replace dipstick and tighten.

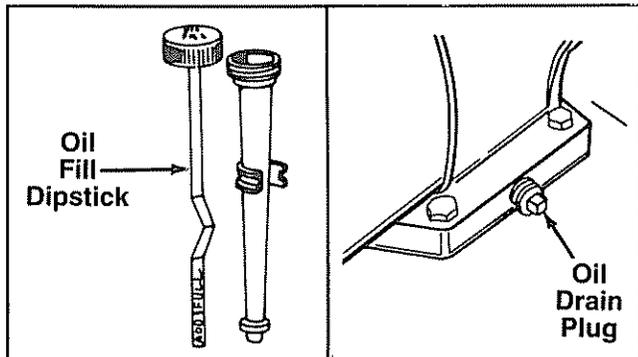

FIGURE 7.

- Remove fuel cap and fill fuel tank. See figure 8. Use fresh, clean, unleaded automotive gasoline. Capacity is 3 quarts. Replace fuel cap.



WARNING: DO NOT FILL CLOSER THAN 1/2 INCH OF TOP OF FUEL TANK TO PREVENT SPILLS AND TO ALLOW FOR FUEL EXPANSION. IF GASOLINE IS ACCIDENTLY SPILLED, MOVE CHIPPER-SHREDDER AWAY FROM AREA OF SPILL. AVOID CREATING ANY SOURCE OF IGNITION UNTIL GASOLINE VAPORS HAVE DISAPPEARED.

Check the fuel level periodically to avoid running out of gasoline while operating the chipper-shredder. If the unit runs out of gas as it is shredding or chipping, it may be necessary to unclog the unit before it can be restarted. Refer to "Removing the Flail Screen" on page 13.

Caution: Experience indicates that alcohol blended fuels (called gasohol or using ethanol or methanol) can attract moisture which leads to separation and formation of acids during storage. Acidic gas can damage the fuel system of an engine while in storage. To avoid engine problems, the fuel system should be empty before storage for 30 days or longer. Refer to "Storage" section of this manual for details. Use fresh fuel each season.

Never use engine or carburetor cleaner products in the fuel tank or permanent damage may result.

NOTE: USE CLEAN OIL AND FUEL. STORE IN APPROVED, CLEAN, COVERED CONTAINERS. USE CLEAN FILL FUNNELS.

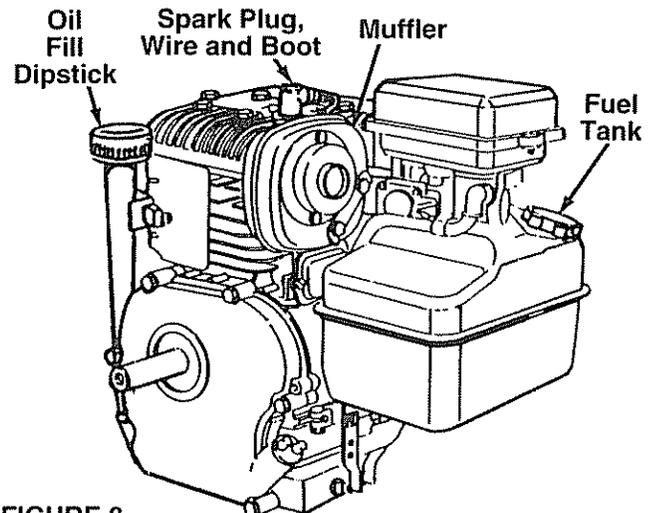

FIGURE 8.
TO START ENGINE



WARNING: BE SURE NO ONE OTHER THAN THE OPERATOR IS STANDING NEAR THE CHIPPER-SHREDDER WHILE STARTING OR OPERATING. DO NOT OPERATE THIS CHIPPER-SHREDDER UNLESS THE CHUTE DEFLECTOR HAS BEEN PROPERLY INSTALLED AND IS SECURED WITH THE HAND KNOBS.

- Attach spark plug wire and rubber boot to spark plug if necessary. See figure 8.
- Place the throttle control lever in FAST position. See figure 9.
- Move choke lever to CHOKE position.
- Grasp starter handle (see figure 9) and pull rope out slowly until engine reaches start of compression cycle (rope will pull slightly harder at this point). Let the rope rewind slowly.

NOTE: A noise will be heard when finding the start of the compression cycle. This noise is caused by the flails and fingers which are part of the shredding mechanism falling into place, and should be expected. In addition, the flails and fingers will be noisy after the engine is started, until the impeller reaches full speed.

- Pull rope with a rapid, continuous, full arm stroke. Keep a firm grip on start handle. Let rope rewind slowly. Do not let starter handle snap back against starter.
- Repeat preceding two instructions until engine fires. When engine starts, move choke lever on engine halfway between CHOKE and RUN.

NOTE: If engine does not fire after three attempts, move choke lever halfway between CHOKE and RUN position and try again. See figure 9.

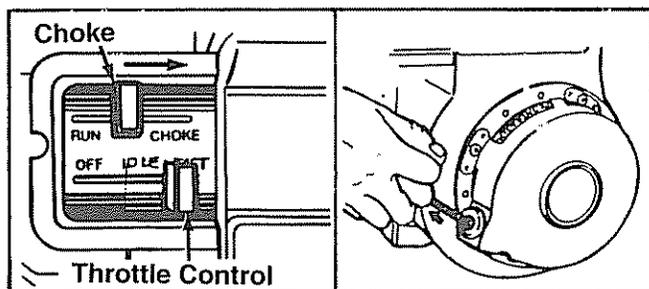

FIGURE 9.

- Move throttle control to IDLE position for a few minutes warm-up. Move choke lever to RUN position as engine warms up.

NOTE: In order to idle smoothly, a new engine may require 3 to 5 minutes running above slow idle speed. Idle speed has been adjusted to be correct after this break-in period.

TO STOP ENGINE

- Move throttle control lever to STOP position. See figure 9.
- Disconnect spark plug wire and move away from spark plug to prevent accidental starting while equipment is unattended.

HOW TO USE YOUR CHIPPER-SHREDDER

Do not attempt to shred or chip any material other than vegetation found in a normal yard (i.e., branches, leaves, twigs, etc.).



WARNING: THE CHIPPER-SHREDDER DISCHARGES MATERIALS WITH CONSIDERABLE VELOCITY. KEEP AWAY FROM THE AREA AROUND THE CHUTE DEFLECTOR. ALWAYS STOP THE ENGINE AND DISCONNECT THE SPARK PLUG WIRE WHEN REMOVING OR ATTACHING THE BAG WHEN CHANGING CONTAINERS OR WHEN REMOVING THE SHREDDED MATERIAL. WEAR SAFETY GLASSES AND GLOVES WHENEVER USING YOUR CHIPPER-SHREDDER.

The chipper-shredder is designed for three different methods of operation.

- Leaves and small branches up to 1/2" diameter can be fed into the hopper assembly when it is in the raised position. See figure 10. If it becomes necessary to push material into the chipper-shredder, use a small diameter stick—NOT YOUR HANDS. The stick should be small enough that it will be ground up if gets into the impeller assembly.



WARNING: DO NOT PUT MATERIAL LARGER THAN 1/2" IN DIAMETER INTO THE HOPPER ASSEMBLY. MATERIAL UP TO A MAXIMUM OF 3" IN DIAMETER MATERIAL MAY BE FED INTO THE CHIPPER CHUTE. DO NOT ATTEMPT TO SHRED OR CHIP ANY MATERIAL LARGER THAN 3" IN DIAMETER. PERSONAL INJURY OR DAMAGE TO THE MACHINE COULD RESULT.

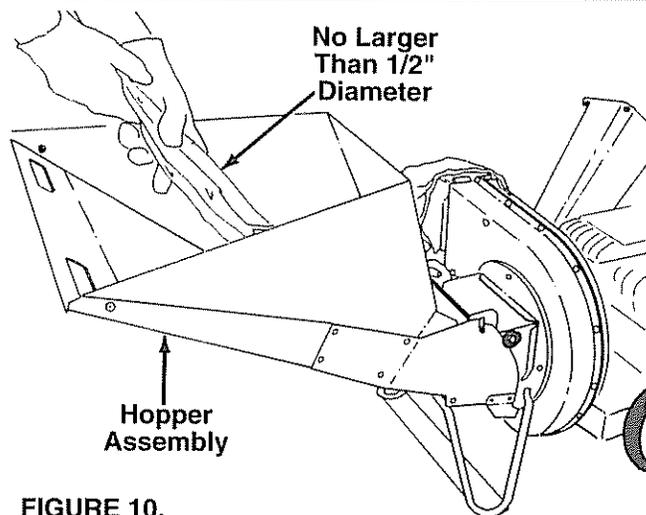

FIGURE 10.

- Leaves and small twigs can be raked into the hopper assembly when the hopper assembly is lowered to the ground. See figure 11. Small branches up to 1/2" diameter can also be fed into the hopper assembly in this position. See figure 12.

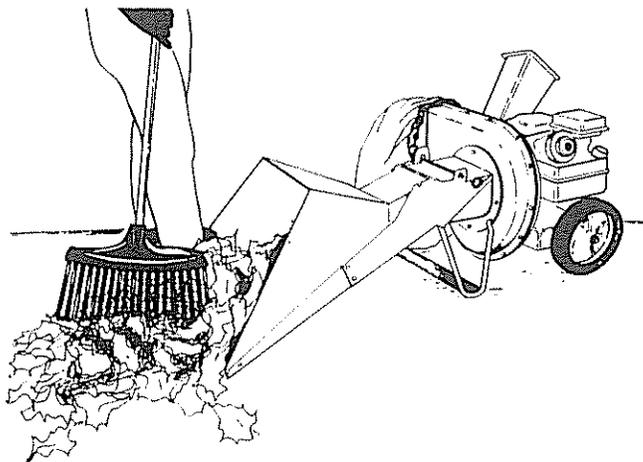

FIGURE 11.

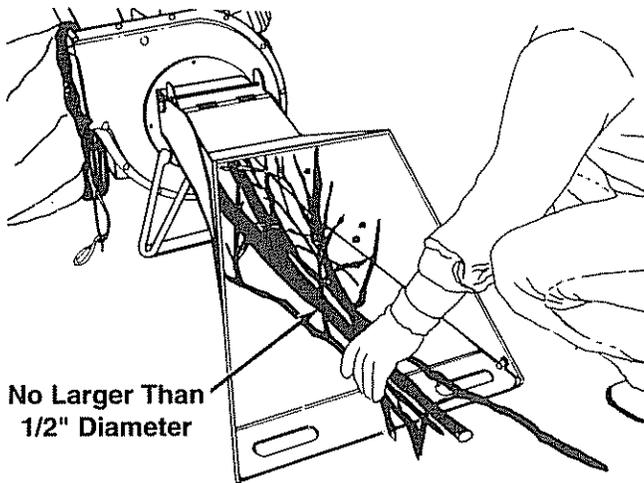

FIGURE 12.

- To lower the hopper assembly, use one hand to grasp the handle at the top of the hopper assembly and lift slightly. Pull up on the release bar, and lower the hopper assembly to the ground. Release the bar. See figure 13.

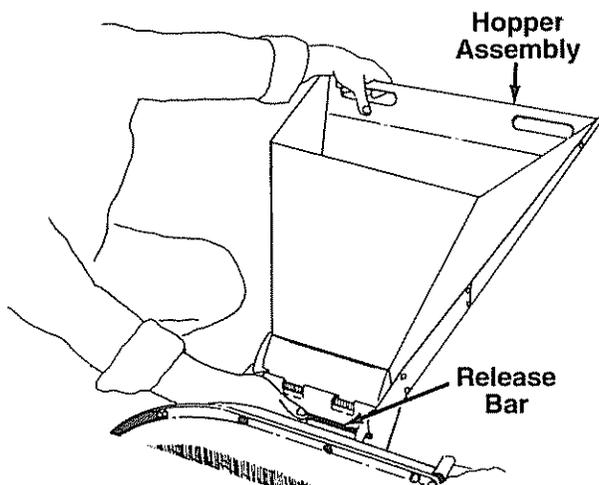

FIGURE 13.

- Bulky material, such as stalks or heavy branches, up to 3" in diameter, should be fed into the chipper chute. See figure 14.



WARNING: MAKE CERTAIN THE CHIPPER CHUTE DOOR IS CLOSED WHEN NOT IN USE.

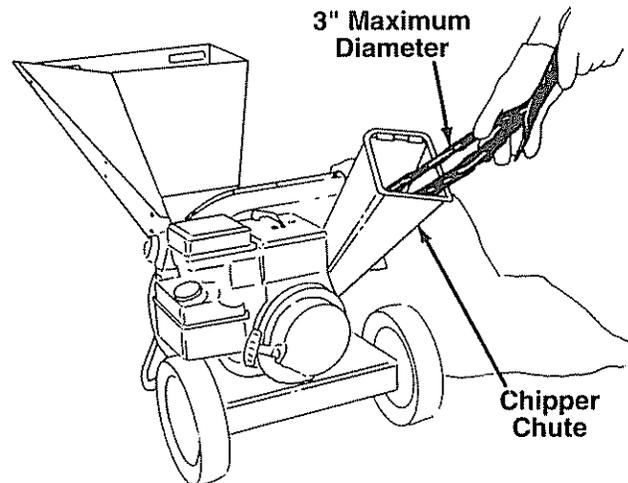

FIGURE 14.

IMPORTANT: There is a flail screen located inside the housing in the discharge area. If the flail screen becomes clogged, remove and clean as instructed in the Service and Adjustments section on page 13. For best performance, it is important to keep the shredding blade and the chipper blades sharp. If the composition of the material being discharged changes (becomes stringy, etc.) or if the rate at which the material is discharged slows down considerably, it is likely that the shredding blade and/or chipper blades are dull and need to be sharpened or replaced. Refer to Service and Adjustments section, page 13.

MAINTENANCE

GENERAL RECOMMENDATIONS

- Periodically check all fasteners and be sure they are tight.
- Follow the Service Recommendation Schedule on page 15.

CHIPPER-SHREDDER LUBRICATION

Lubricate the pivot points on the release bar, hopper assembly, chute deflector and chipper chute once a season using a light oil.

ENGINE LUBRICATION

Check engine oil level regularly—approximately every five hours of operation and before each usage. Stop engine and wait several minutes before checking oil level. With engine level, the oil must be to FULL mark on dipstick (refer to figure 7). Change engine oil after the first five hours of operation, and every twenty-five hours thereafter.

- Drain oil while engine is warm.

Remove oil drain plug. Refer to figure 7. Tip the chipper-shredder, and catch oil in a suitable container.

When engine is drained of all oil, replace drain plug securely.

- Refill with fresh oil. Above 32°, use oil labeled SAE 30 or 10W30. Below 32°, use oil labeled 5W20. Capacity is approximately 1-1/4 pints. Refer to "Gas and Oil Fill-Up" on page 8.
- Replace dipstick.

AIR CLEANER

The air cleaner prevents damaging dirt, dust, etc., from entering the carburetor and being forced into the engine and is important to engine life and performance.

Never run your engine without air cleaner completely assembled.

To Service Air Cleaner:

Clean cartridge at three month intervals or every 25 hours, whichever occurs first. See figure 15. Service more often under dusty conditions.

- Loosen screws and tilt cover as illustrated.
- Carefully remove pre-cleaner and cartridge.
- Clean cartridge by tapping gently on a flat surface. If very dirty, replace cartridge and pre-cleaner or clean as follows:

Wash in a low or non-sudsing detergent and warm water solution. **CAUTION:** Do not use petroleum solvents such as kerosene to clean cartridge.

Rinse thoroughly with flowing water from inside out until water is clear.

Allow cartridge to stand and air dry **thoroughly** before using. **DO NOT OIL CARTRIDGE OR PRE-CLEANER. DO NOT USE PRESSURIZED AIR TO CLEAN OR DRY CARTRIDGE.**

- Install cartridge and pre-cleaner. Then close cover and fasten screws securely.

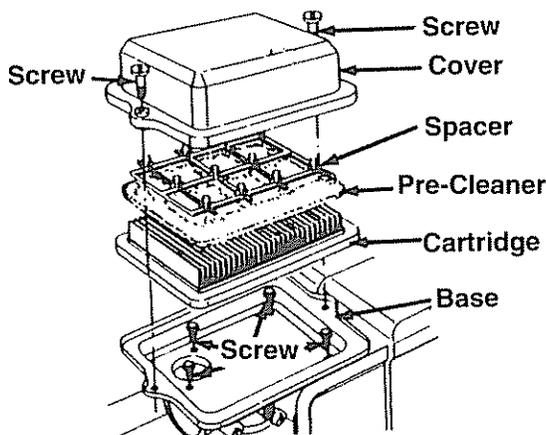

FIGURE 15.

CLEAN ENGINE

Clean engine periodically. Remove dirt and debris with a cloth or brush. Cleaning with a forceful spray of

water is not recommended as water could contaminate the fuel system.

Yearly or every 25 hours, whichever occurs first, remove the blower housing and clean the areas shown in figure 16 to avoid overspeeding, overheating and engine damage. Clean more often if necessary.



WARNING: PERIODICALLY CLEAN MUFFLER AREA TO REMOVE ALL GRASS, DIRT AND COMBUSTIBLE DEBRIS.

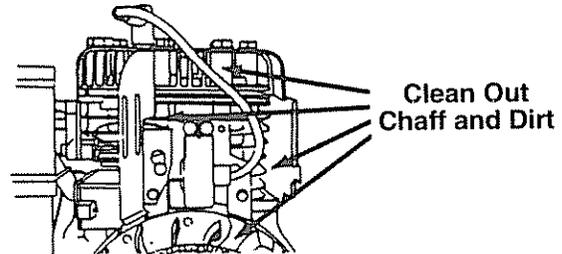

FIGURE 16.

SPARK PLUG

The spark plug should be cleaned and the gap reset to .030" at least once a season or every 50 hours of operation. See figure 17. Spark plug replacement is recommended at the start of each season. Refer to engine parts list for correct spark plug type.

NOTE: Do not sandblast spark plug. Spark plug should be cleaned by scraping or wire brushing and washing with a commercial solvent.

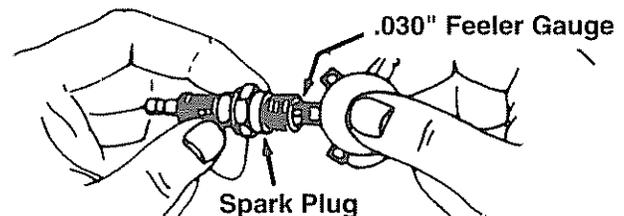

FIGURE 17.

MUFFLER

Do not operate the chipper-shredder without a muffler or tamper with the exhaust system. Damaged mufflers or spark arresters could create a fire hazard. Inspect periodically, and replace if necessary. If your engine is equipped with a spark arrester screen assembly, remove every 50 hours for cleaning and inspection. Replace if damaged.

CLEANING

- The chipper-shredder may be cleaned by running water from a hose through the hopper assembly and chipper chute with the engine running. Allow the chipper-shredder to dry thoroughly.
- Wash the bag periodically with water. Allow to dry thoroughly in the shade. Do not use heat.

STORAGE



NEVER STORE YOUR CHIPPER-SHREDDER INDOORS OR IN AN ENCLOSED, POORLY VENTILATED AREA IF GASOLINE REMAINS IN THE TANK. FUMES MAY REACH AN OPEN FLAME, SPARK OR PILOT LIGHT FROM A FURNACE, WATER HEATER, CLOTHES DRYER, CIGARETTE, ETC.

To prevent engine damage if chipper-shredder is not used for more than 30 days, follow the steps below.

NOTE: GASOLINE MUST BE REMOVED OR TREATED TO PREVENT GUM DEPOSITS FROM FORMING IN THE TANK, FILTER, HOSE AND CARBURETOR DURING STORAGE. ALSO DURING STORAGE, ALCOHOL-BLENDED GASOLINE THAT USES ETHANOL OR METHANOL (SOMETIMES CALLED GASOHOL) ATTRACTS WATER. IT ACTS ON THE GASOLINE TO FORM ACIDS WHICH DAMAGE THE ENGINE.

To remove gasoline, run engine until tank is empty and engine stops. Then disconnect fuel line at carburetor or fuel tank. Be careful not to damage fuel line, fittings or fuel tank. Drain any remaining fuel from the system. If you do not want to remove gasoline, Sears Craftsman Fuel Stabilizer No. 33500 may be added to

any gasoline left in the tank to minimize gum deposits and acids. If the tank is almost empty, mix stabilizer with fresh gasoline in a separate container and add some to the tank. **Always follow instructions on stabilizer container. Then run engine at least 10 minutes after stabilizer is added to allow mixture to reach carburetor. Store chipper-shredder in safe place. See warning in previous column.**

You can help keep your engine in good operating condition during storage by:

- Changing oil.
- Lubricating the piston/cylinder area by first removing the spark plug and squirting clean engine oil into the spark plug hole. Then cover the spark plug hole with a rag to absorb oil spray. Next, rotate the engine by pulling the starter two or three times. Finally, reinstall spark plug and attach spark plug wire.

Protect the chipper-shredder during storage by:

- Thoroughly cleaning the chipper-shredder.
- If storing in an unventilated or metal storage shed, coat metal parts with a light oil or silicone to prevent rust.
- Store in a clean, dry area. Do not store next to corrosive materials, such as fertilizer.

SERVICE & ADJUSTMENT



WARNING: ALWAYS STOP ENGINE AND DISCONNECT SPARK PLUG WIRE AND MOVE IT AWAY FROM SPARK PLUG BEFORE PERFORMING ANY ADJUSTMENTS OR REPAIRS.

REMOVING THE FLAIL SCREEN

If the discharge area becomes clogged, remove the flail screen and clean area as follows.

- Stop the engine, make certain the chipper-shredder has come to a complete stop and disconnect spark plug wire from the spark plug before unclogging the chute.
- Loosen the two hand knobs on each side of the chute deflector. Lift the chute deflector up, and tie it out of the way.
- Remove two hairpin clips from the clevis pins which extend through the housing. Remove the clevis pins. Lift the flail screen from inside the housing. See figure 18.
- Clean the screen by scraping or washing with water. Reinstall the screen.

NOTE: Be certain to reassemble the flail screen with the curved side down as shown in figure 18.

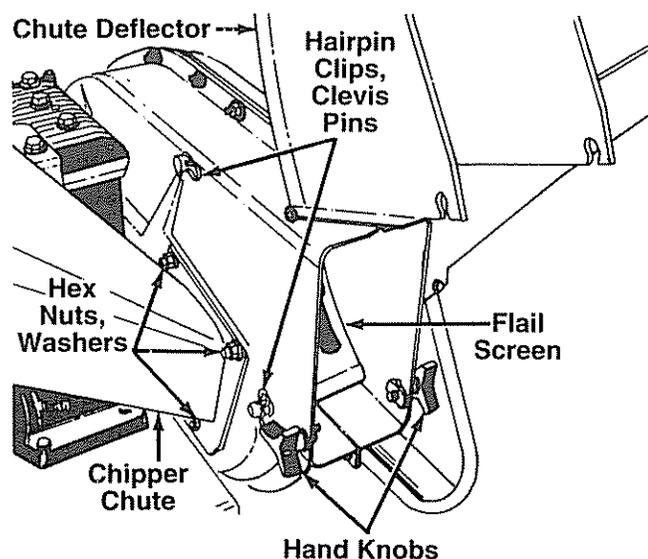

FIGURE 18.

SHARPENING OR REPLACING THE BLADES CHIPPER BLADES

- Disconnect spark plug wire and move it away from spark plug.
- Remove the flail screen as instructed in previous section.
- Remove the chipper chute by removing three hex nuts and washers. A 1/2" wrench is required. See figure 18.

NOTE: When reassembling, the cupped washer goes on the bottom of the chipper chute with the cupped side against the chute.

- Rotate the impeller assembly by hand until you locate one of the chipper blades in the chipper chute opening. Remove the blade, using a 3/16" allen wrench on the outside of the blade and 1/2" wrench on the impeller assembly (inside the housing). See figure 19.
- Remove the other blade in the same manner.

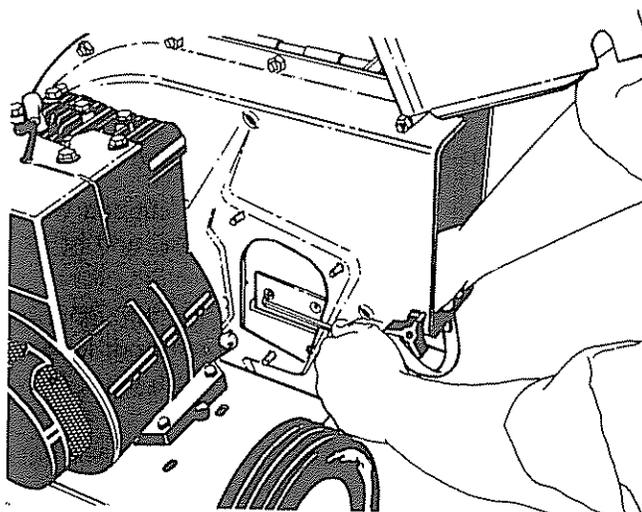

FIGURE 19.

Replace or sharpen blades. If sharpening, make certain to remove an equal amount from each blade. Reassemble in reverse order.

Make certain blades are reassembled with the sharp edge facing the direction shown in figure 19 (sharp edge is assembled toward the slotted opening in the impeller assembly).

SHREDDING BLADE

The shredding blade may be removed for sharpening or replacement as follows.

- Disconnect spark plug wire and move it away from spark plug.
- Lower the hopper assembly. Block up the housing. See figure 20.
- Remove the six hex lock nuts and lock washers from the housing weld bolts using a 1/2" wrench. Separate the chipper-shredder into two halves.
- Remove the back-up plate.

NOTE: When reassembling, make certain the opening on the back-up plate is toward the bottom of the unit. The back-up plate may be reversed to provide a new cutting edge.

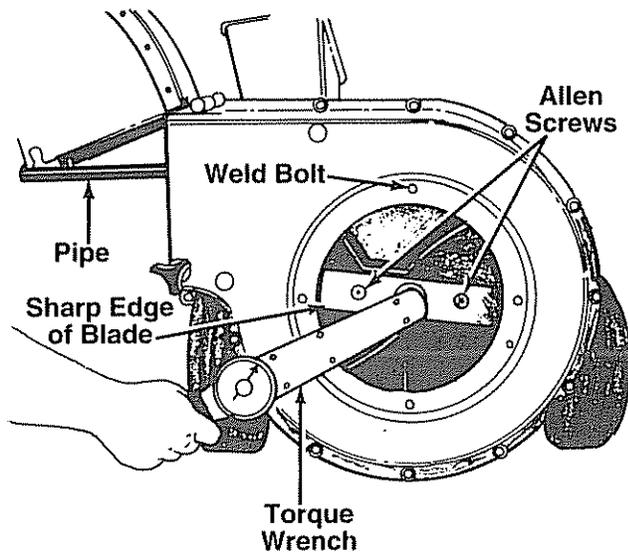

FIGURE 20.—Model 247.797853 Shown

- Loosen the two hand knobs and cupped washers which secure the chute deflector, and raise the chute deflector.
- Insert a 1/2" or 3/4" diameter pipe through the flail screen into the impeller to keep it from turning, or remove the flail screen and insert a piece of wood (2 x 4) into the chute opening.
- **Model 247.797853 only:** Remove the two outside screws on the blade, using a 3/16" allen wrench and a 1/2" wrench.
- Remove the blade by removing the center bolt, lock washer and flat washer.

NOTE: Use caution when removing the blade to avoid contacting the weld bolts on the housing.

- When sharpening the blade, follow the original angle of grind as a guide. It is extremely important that each cutting edge receives an equal amount of grinding to prevent an unbalanced blade. An unbalanced blade will cause excessive vibration when rotating at high speeds and may cause damage to the unit.
- The blade can be tested for balance by balancing it on a round shaft screwdriver or nail. Remove metal from the heavy side until it is balanced evenly. See figure 21.

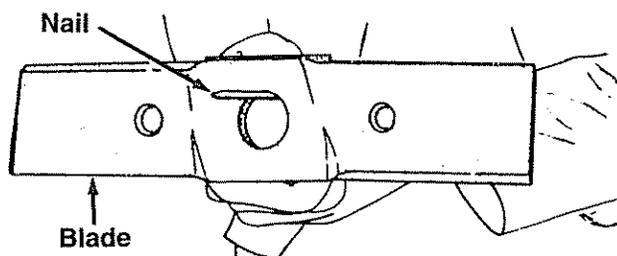

FIGURE 21.

- When reassembling the blade, tighten to between 550 and 650 inch pounds, or lacking torque wrench, tighten securely.

FLAILS

The flails, located inside the housing, may be reversed when they become dull. It is suggested that this procedure be performed by your nearest Sears Service Department.

CARBURETOR ADJUSTMENT



WARNING: IF ANY ADJUSTMENTS ARE MADE TO THE ENGINE WHILE THE ENGINE IS RUNNING (E.G. CARBURETOR), KEEP CLEAR OF ALL MOVING PARTS. BE CAREFUL OF HEATED SURFACES AND MUFFLER.

Minor carburetor adjustment may be required to compensate for differences in fuel, temperature, altitude or load.

NOTE: A DIRTY AIR CLEANER WILL CAUSE ENGINE TO RUN ROUGH. BE CERTAIN AIR CLEANER IS CLEAN AND ATTACHED TO THE CARBURETOR BEFORE ADJUSTING CARBURETOR. DO NOT MAKE UNNECESSARY ADJUSTMENTS. FACTORY SETTINGS ARE SATISFACTORY FOR MOST APPLICATIONS AND CONDITIONS.

Never attempt to change maximum engine speed. It is pre-set at the factory and should be changed only by a qualified service technician who has the necessary equipment.

The carburetor may need re-adjusting if engine lacks power or does not idle properly. If adjustments are needed, proceed as follows.

- Close needle valve (see figure 22) clockwise (↻) finger tight only. Forcing may cause damage. Then open 1-1/2 turns counterclockwise (↺).
- Start engine and allow to warm for five minutes.
- With throttle in FAST position, close needle valve clockwise (↻) until engine starts to lose speed (lean mixture). Then slowly open needle valve counterclockwise (↺) until engine JUST BEGINS to run unevenly. This mixture should be rich enough for best performance under load.
- Place throttle control in IDLE position.
 - If engine idles, no further adjustment is necessary.
 - If engine idles too fast, turn idle speed adjusting screw counterclockwise (↺) until slower speed is obtained.
 - If engine dies, turn idle speed adjusting screw 1/4 turn clockwise (↻). Place throttle control in FAST position and restart engine.
 - Move throttle control to IDLE position. If engine does not idle, repeat step c.

- Test the engine by using the chipper-shredder. If engine tends to stall or die out, it usually indicates that the mixture is slightly lean and it may be necessary to open (↷) the needle valve slightly to provide a richer mixture. This richer mixture may cause a slight unevenness in idling.

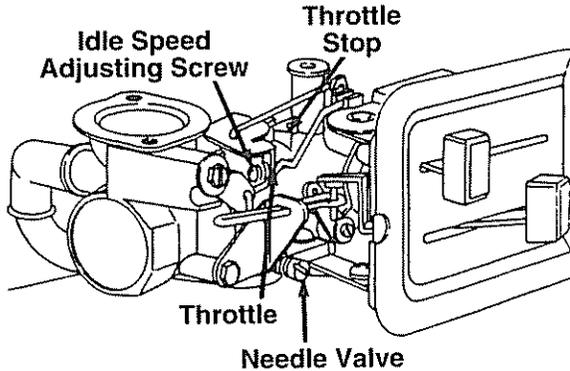

ENGINE SPEED

Your engine speed has been factory set. Do not attempt to increase engine speed or it may result in personal injury. If you believe the engine is running too fast or too slow, take your chipper-shredder to the nearest SEARS Service Center for repair and adjustment.

FIGURE 22.

SERVICE RECOMMENDATIONS

SERVICE RECORD Fill in dates as you complete regular service	SCHEDULE						SERVICE DATES			
	First 5 Hours	Before Each Use	Every 25 Hours	Every 50 Hours	Begin- ning Each Season	Before Storage				
Check Fuel		√								
Drain Fuel						√				
Check Engine Oil Level		√			√					
Change Engine Oil	√		√							
Oil Pivot Points						√				
Service Air Cleaner			√							
Clean Engine Cylinder Fins			√		√					
Replace or Clean Spark Plug				√		√				
Spark Arrester Muffler				√						

The Service Recommendations Chart is supplied to assist the operator in proper maintenance of the chipper-shredder. This is only a check list; instructions will be found in the Maintenance and Service Adjustment sections of this manual.

TROUBLE SHOOTING

PROBLEM	POSSIBLE CAUSE(S)	CORRECTIVE ACTION
Engine fails to start	<ul style="list-style-type: none"> • Fuel tank empty, or stale fuel. • Spark plug wire disconnected. • Faulty spark plug. 	<ul style="list-style-type: none"> • Fill tank with clean, fresh fuel. • Connect wire to spark plug. • Clean, adjust gap or replace.
Loss of power; operation erratic	<ul style="list-style-type: none"> • Spark plug wire loose. • Unit running on CHOKE • Blocked fuel line or stale fuel • Water or dirt in fuel system. • Carburetor out of adjustment. • Dirty air cleaner. 	<ul style="list-style-type: none"> • Connect and tighten spark plug wire • Move choke lever to OFF position. • Clean fuel line; fill tank with clean fresh gasoline. • Disconnect fuel line at carburetor to drain fuel tank. Refill with fresh fuel. • Adjust carburetor or contact your SEARS Service Center. • Service air cleaner See Maintenance section of this manual
Engine overheats	<ul style="list-style-type: none"> • Carburetor not adjusted properly. • Engine oil level low. 	<ul style="list-style-type: none"> • Contact your SEARS Service Center. • Fill crankcase with proper oil.
Too much vibration	<ul style="list-style-type: none"> • Loose parts or damaged impeller. 	<ul style="list-style-type: none"> • Stop engine immediately and disconnect spark plug wire. Tighten all bolts and nuts. Make all necessary repairs. If vibration continues, have unit serviced by a SEARS Service Center.
Unit does not discharge	<ul style="list-style-type: none"> • Discharge chute clogged. • Foreign object lodged in impeller 	<ul style="list-style-type: none"> • Stop engine immediately and disconnect spark plug wire. Clean flail screen and inside of blower housing. See Service/Adjustments section of this manual. • Stop engine immediately and disconnect spark plug wire. Remove lodged object.
Rate of discharge slows considerably or composition of discharged material changes	<ul style="list-style-type: none"> • Shredding blade and/or chipper blades dull. 	<ul style="list-style-type: none"> • Sharpen or replace shredding and chipper blades.

NOTE: For repairs beyond the minor adjustments listed above, please contact your nearest SEARS Service Center.

**SEARS CRAFTSMAN 5 H.P. CHIPPER-SHREDDER MODEL NOS. 247.797852
247.797853**

Repair Parts

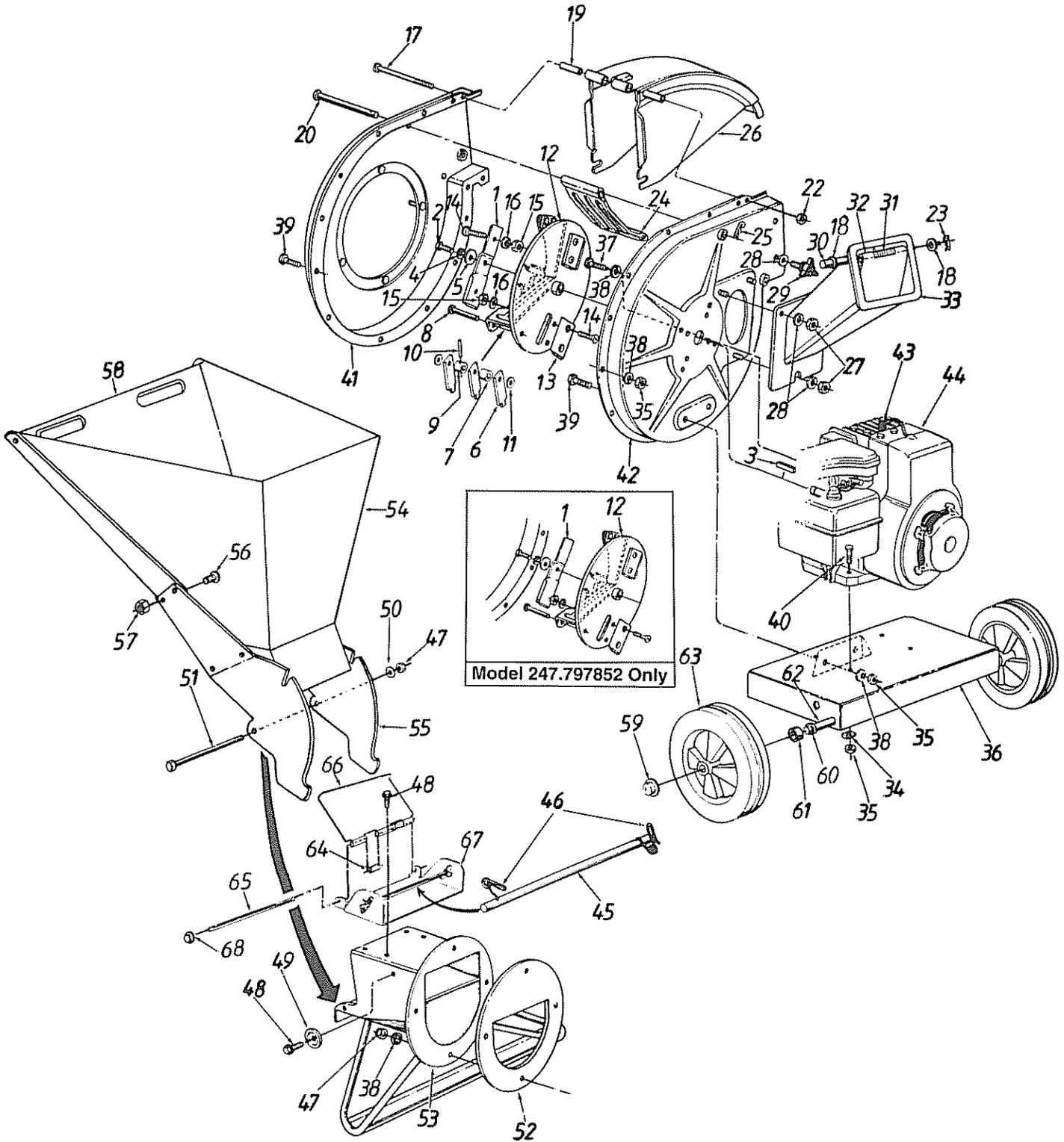

**SEARS CRAFTSMAN 5 H.P. CHIPPER-SHREDDER MODEL NOS. 247.797852
247.797853**

Repair Parts

KEY NO.	PART NO.	DESCRIPTION	KEY NO.	PART NO.	DESCRIPTION
1	13431	Blade (247.797852)	37	710-0157	Hex Bolt 5/16-24 x .75" Lg.
	742-0571	Blade (247.797853)	38	736-0119	L-Wash. 5/16" I.D.*
2	710-0818	Hex Patch Bolt 3/8-24 x 2" Lg. (Gr. 8)	39	710-3008	Hex Bolt 5/16-18 x .75" Lg. (Gr. 5)
3	714-0114	Sq. Key 1/4 x 2.0" Lg.	40	710-0380	Hex Bolt 5/16-18 x 1.75" Lg.*
4	736-0217	L-Wash. 3/8" I.D. H.D.	41	681-0004	Flail Housing Ass'y.—L.H.
5	736-0247	FI-Wash. .406" I.D. x 1.25" O.D. Hdn.	42	781-0474A	Flail Housing Ass'y.—R.H.
6	11459B	Flail	43	735-0639	Spark Plug Boot
7	711-0564	Flail Spacer	44	130212-3250-01	Engine—B&S 130212-3250-01
8	711-0833A	Clevis Pin .496" Dia.	45	747-0531A	Release Bar
9	711-0834	Flail Spacer w/.160" Dia. Hole	46	742-0546	Torsion Spring 1.06" Lg.
10	715-0249	Spring Roll Pin 1.12" Lg.	47	712-0429	Elastic Lock Nut 5/16-18 Thd.
11	736-0192	FI-Wash. .531" I.D. x .94" O.D.	48	710-0601	Hex Wash. Hd. Self-Tap Scr. 5/16-18 x .75" Lg.
12	781-0484	Impeller Ass'y. (247.797852)	49	11480	Stop Washer
	681-0002	Impeller Ass'y. (247.797853)	50	736-0264	FI-Wash. 5/16" I.D.
13	781-0490	Chipper Blade	51	710-0542	Hex Bolt 5/16-18 x 8.38" Lg.
14	710-1054	Flat Hd. Scr. 5/16-24 x .75" Lg.	52	781-0487B	Back-Up Plate
15	712-0411	Hex Top L-Nut 5/16-24 (Gr. 5)	53	16522B	Inlet Guide Ass'y.
16	736-0119	L-Wash. 5/16" I.D.*	54	781-0494	Pivot Hopper Hood
17	710-0825	Hex Bolt 1/4-20 x 3.75" Lg.*	55	16524B	Upper Guide Ass'y.
18	736-0142	FI-Wash. .281" I.D. x .50" O.D.	56	710-0286	Truss Mach. Scr. 1/4-20 x .5" Lg.
19	750-0793	Chute Hinge Spacer 1.66" Lg.	57	712-0107	Hex L-Nut 1/4-20 Thd.
20	711-0835	Clevis Pin .5" Dia. x 4.62" Lg.	58	11461B	Upper Leaf Ramp Section
22	712-0291	Hex Ctr. L-Nut 1/4-20 Thd.	59	726-0214	Push Cap 5/8" Dia. Rod
23	714-3010	Cotter Pin	60	736-0187	FI-Wash. .64" I.D. x 1.24"
24	781-0457	Shredder Screen	61	750-0786	Spacer .64" I.D. x .38" Lg.
25	714-0149B	Internal Cotter Pin 3/8" Dia.	62	738-0814	Shredder Axle
26	781-0480	Chute Deflector Ass'y.	63	734-1600	Wheel Ass'y. Comp.
27	712-3010	Hex Nut 5/16-18 Thd. (Gr. 5)	64	732-0629	Torsion Spring
28	736-0242	Bell-Wash. .345" I.D. x .88"	65	747-0747	Hopper Door Rod
29	720-0170	Hand Knob	66	781-0492	Hopper—Pivot Door
30	747-0744A	Chipper Door Rod	67	781-0493	Hopper Lockout Brkt.
31	732-0542	Torsion Spring 1.14" Lg.	68	726-0106	Cap Speed Nut 1/4" Rod
32	781-0489	Chipper Door	—	764-0199A	Bag (Not Shown)
33	781-0475	Chipper Chute Ass'y.	—	723-0400	Safety Glasses (Not Shown)
34	736-0170	Spec. L-Wash. 5/16" I.D.	—	770-7110G	Owner's Manual
35	712-3010	Hex Nut 5/16-18 Thd. (Gr. 5)			
36	781-0510	Shredder Frame			

*Common Hardware—May Be Purchased Locally.

NOTE: Specifications subject to change without notice or obligation.

BRIGGS AND STRATTON 5 H.P. ENGINE MODEL NO. 130212-3250-01

Repair Parts

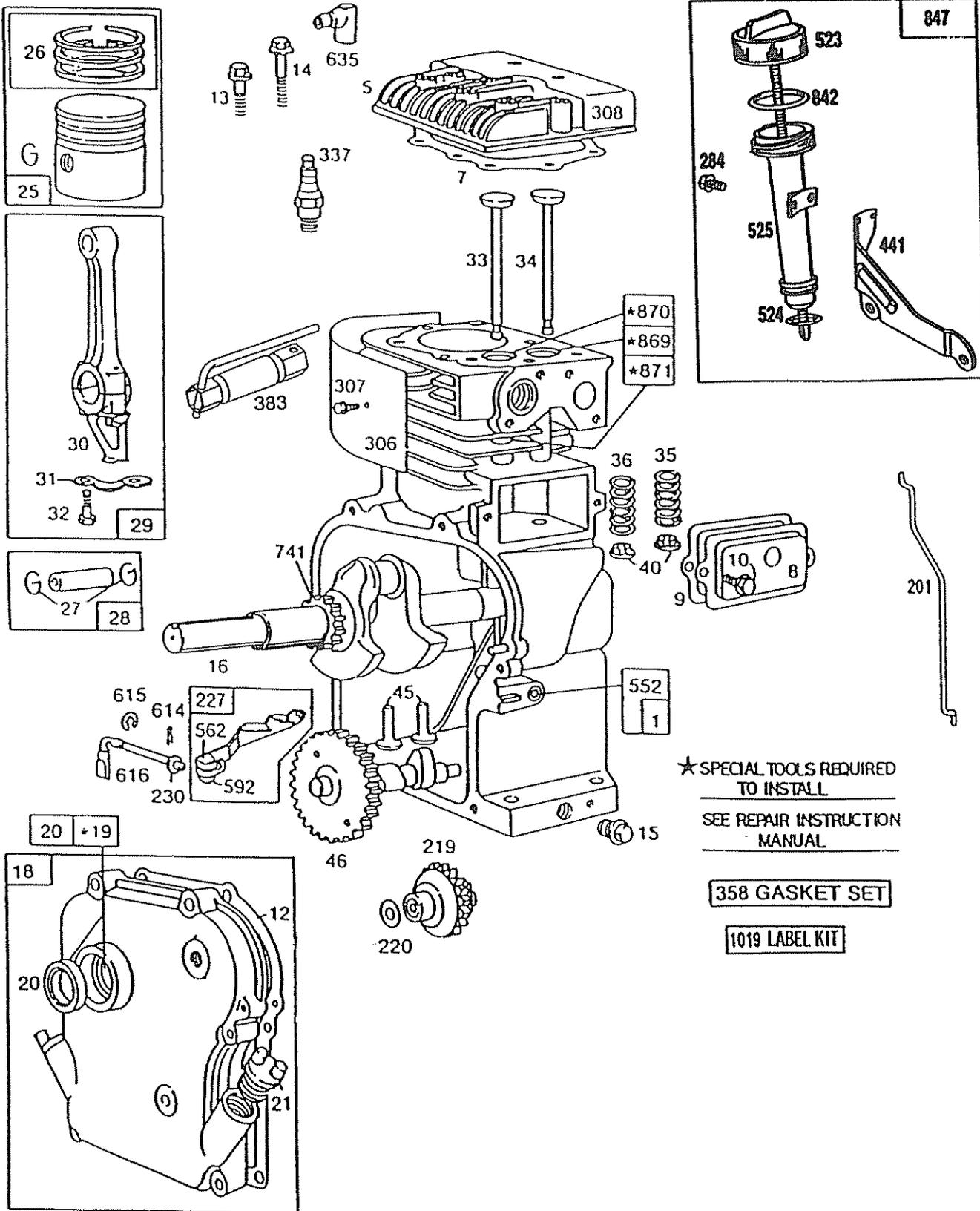

★ SPECIAL TOOLS REQUIRED TO INSTALL
SEE REPAIR INSTRUCTION MANUAL

358 GASKET SET

1019 LABEL KIT

BRIGGS AND STRATTON 5 H.P. ENGINE MODEL NO. 130212-3250-01
Repair Parts

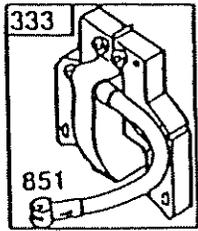

335

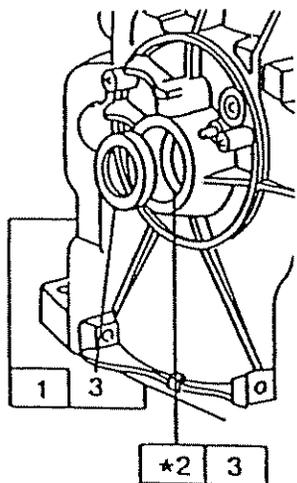
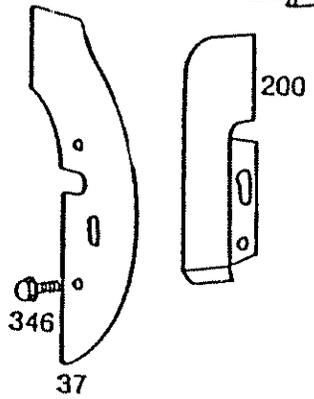
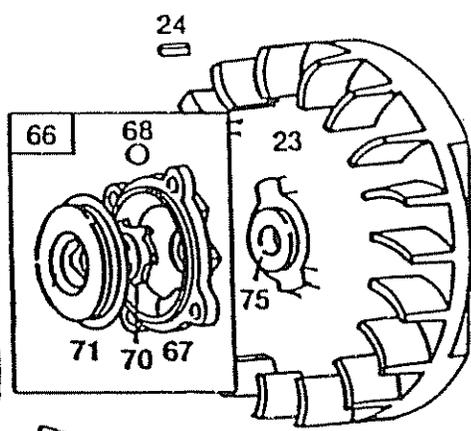
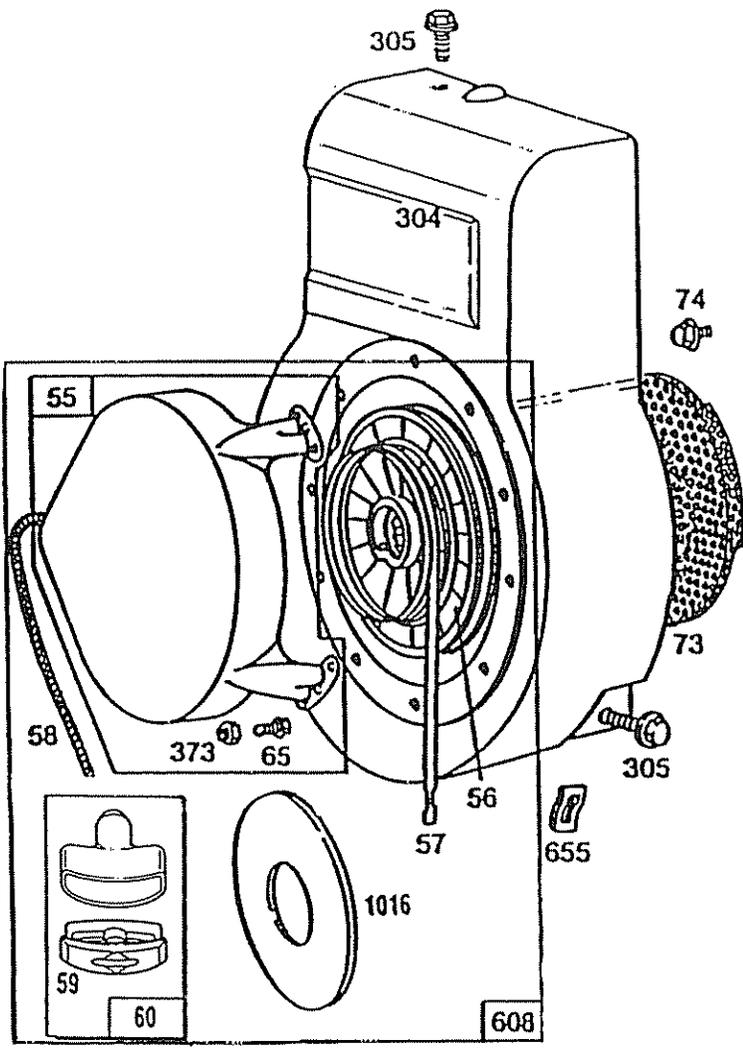
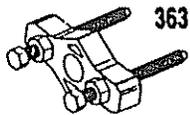

***REQUIRES
 SPECIAL TOOLS
 TO INSTALL.
 SEE REPAIR
 INSTRUCTION
 MANUAL.**

BRIGGS AND STRATTON 5 H.P. ENGINE MODEL NO. 130212-3250-01
Repair Parts

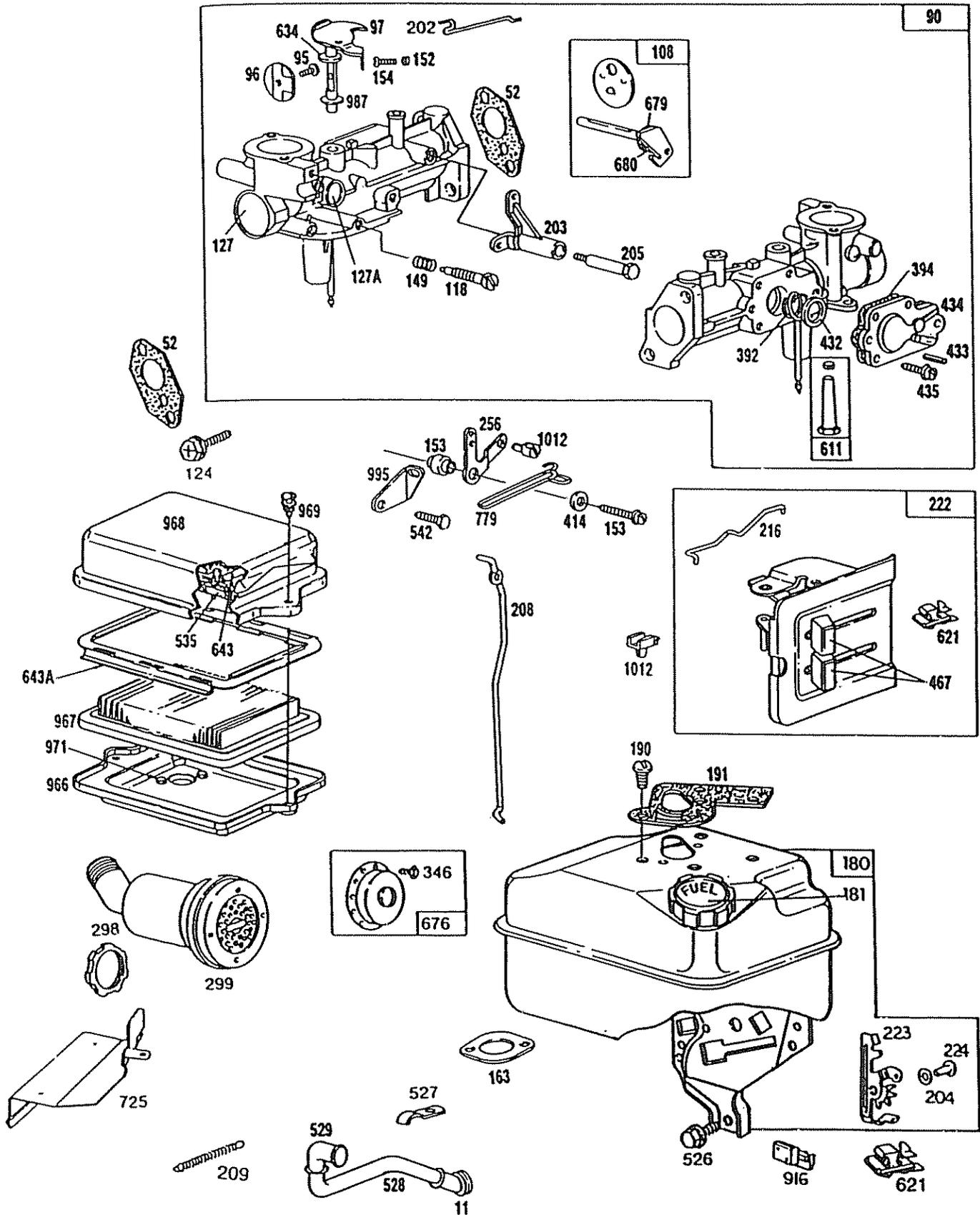

BRIGGS AND STRATTON 5 H.P. ENGINE MODEL NO. 130212-3250-01

Repair Parts

KEY NO.	PART NO.	DESCRIPTION	KEY NO.	PART NO.	DESCRIPTION
1	395990	Cylinder Assembly	32	92296	Screw—Connecting Rod
2	297565	Bushing—Cylinder Note: Requires special tools for installation.	33	211119	Valve—Exhaust
3	299819	Seal—Oil	34	261044	Valve—Intake
5	211542	Head—Cylinder	35	260552	Spring—Intake Valve
7	*272157	Gasket—Cylinder Head	36	26478	Spring—Exhaust Valve
8	294178	Breather—Valve Chamber	37	222443	Guard—Flywheel
9	*27549	Gasket—Valve Cover	40	93312	Retainer—Valve Spring
10	93394	Screw—Breather Mtg. Sem	45	260642	Tappet—Valve
11	66578	Grommet—Breather Tube	46	212733	Gear—Cam
12	*270080	Gasket—Crankcase—.015" Thick (Standard)	52	*271936	Gasket—Carburetor Mounting
	*270125	Gasket—Crankcase—.005" Thick	55	299431	Housing—Rewind Starter
	*270126	Gasket—Crankcase—.009" Thick	56	295871	Pulley—Rewind Starter
13	94221	Screw—Cylinder Head (2-3/32" Long)	57	490179	Spring—Rewind Starter
14	93369	Screw—Cylinder Head (2-15/32" Long)	58	66884	Rope—Rewind Starter—63" Long
15	91249	Plug—Pipe, 1/4" Std. Square Head	59	490653	Insert—Starter Handle
16	492926	Crankshaft To Replace Crankshaft Gear Pin, Order Part No. 230978	60	490652	Handle—Rewind Starter
18	493916	Cover Ass'y.	65	94128	Screw—Stamped Steel Housing Mtg. Sem
19	297603	Bushing—Crankcase Cover Note: Requires special tools for installation.	66	399671	Clutch Ass'y.—Rewind Starter
20	298504	Seal—Oil	67	394897	Housing—Starter Clutch
21	66768	Plug—Oil Filler	68	63770	Ball—Clutch
22	94607	Screw—Crankcase Cover Mounting Sem	70	298799	Ratchet—Rewind Starter
23	297229	Flywheel—Magnet	71	394506	Washer—Clutch Retainer
24	222698	Key—Flywheel	73	221923	Screen—Starter Pulley
25	298904	Piston Ass'y.—Standard	74	93490	Screw—Sem
	298905	Piston Ass'y.—.010" O.S.	75	224061	Washer—Spring
	298906	Piston Ass'y.—.020" O.S.	90	492611	Carburetor Assembly
	298907	Piston Ass'y.—.030" O.S.	95	93499	Screw—Throttle Valve to Shaft Sem
		PISTON RING SETS: Note: For Chrome Piston Ring Set—Standard Size—Order Part No. 299742.	96	223793	Throttle—Carburetor
26	298982	Ring Set—Standard Piston	97	490048	Shaft and Lever—Throttle
	298983	Ring Set—.010" O.S. Piston	108	491177	Valve Group—Choke
	298984	Ring Set—.020" O.S. Piston	118	231533	Valve—Needle
	298985	Ring Set—.030" O.S. Piston	124	93357	Screw—Hex. Head
27	26026	Lock—Piston Pin	127	220352	Plug—Welch
28	298909	Pin Ass'y.—Piston—Standard	127A	223789	Plug—Welch (Mixing Chamber)
	298908	Pin Ass'y.—Piston—.005" O.S.	149	26336	Spring—Needle Valve
29	299430	Rod Ass'y.—Connecting Note: For Connecting Rod with .020" undersize Crankpin Bore—Order No. 390459.	152	260575	Spring—Throttle Adjustment
30	221890	Dipper—Connecting Rod	153	490589	Screw Ass'y.
31	221876	Lock—Conn. Rod Screw	154	93527	Screw—Machine, Rd. Hd.—5-40 x 5/8"
			163	271935	Gasket—Air Cleaner Mounting
			180	492927	Tank Assembly—Fuel
			181	490075	Cap—Fuel Tank
			190	94094	Screw—Fuel Tank Mounting Sem
			191	*271928	Gasket—Fuel Tank Mounting
			200	223886	Guide—Air
			201	262280	Link—Governor
			202	262270	Link—Throttle
			203	280720	Crank—Bell
			204	222962	Bushing—Governor Lever (Flat)
			205	231520	Screw—Shoulder
			208	262279	Rod—Control
			209	262283	Spring—Governor

BRIGGS AND STRATTON 5 H.P. ENGINE MODEL NO. 130212-3250-01

Repair Parts

KEY NO.	PART NO.	DESCRIPTION	KEY NO.	PART NO.	DESCRIPTION
216	262359	Link—Choke	535	491435	Element—Air Cleaner
219	391737	Gear—Governor	542	93572	Screw
220	221551	Washer—Thrust	552	231079	Bushing—Governor Crank (1/4" I.D.)
222	490649	Bracket—Control	562	92613	Bolt—Governor Lever
223	223455	Lever—Governor Control	592	231082	Nut—Hex —10-24
224	93491	Rivet—Governor Control Lever Mounting	608	390463	Starter Ass'y.—Rewind
227	490374	Lever Ass'y.—Governor	611	391813	Fuel Pipe and Clip Assembly
230	222450	Washer—Governor Lever	614	93306	Cotter—Hairpin
256	223813	Bell Crank	615	93307	Retainer—E-Ring
284	94419	Screw—Self-Tapping	616	231077	Crank—Governor (1/4" Dia.)
298	261409	Lock Nut—Muffler	621	396847	Switch—Stop
299	393368	Muffler—Exhaust	634	271853	Washer—Throttle Shaft (Foam)
304	490169	Housing—Blower	635	66538	Elbow—Spark Plug
305	94608	Screw—Blower Housing Mounting	643	280737	Retainer—Foam Element
306	221511	Shield—Cylinder	643A	280726	Retainer—Air Filter
307	93758	Screw—Cylinder Shield Mounting Sem	655	222598	Anchor Spring
308	221512	Cover—Cylinder Head	676	395700	Deflector—Exhaust (Direct Outlet)
333	397358	Armature Assembly	679	270382	Washer Choke Shaft (Foam)
335	93414	Screw—Armature Mtg. Sem	680	221839	Washer Choke Shaft (Brass)
337	492167	Plug—Spark 7/8" High— 48 M.M.	725	223867	Shield—Heat
346	93705	Screw—Sem	741	261696	Gear—Timing
356	398808	Wire—Ground	779	262276	Link—Bell Crank
358	397145	Gasket Set	842	270920	Seal—Tube
363	19069	Flywheel Puller (Optional Accessory)	847	493367	Oil Fill Ass'y.
373	92987	Nut—Hex	851	221798	Cable Terminal—Ignition
383	89838	Wrench—Spark Plug	869	211787	Seat—Intake Valve (Standard)
392	262328	Spring—Fuel Pump Diaphragm	870	211172	Seat—Exhaust Valve (Standard)
394	270026	Diaphragm	871	262001	Note: For Options see Repair Manual. Guide—Exhaust Valve
414	220982	Washer	916	280321	Note: 63709 Guide—Intake Valve. See Repair Instruction Manual. Gear Rack—Governor
432	221377	Cap—Spring	966	492797	Base—Air Cleaner
433	93265	Pin—Diaphragm Cover	967	491588	Filter—Air
434	210959	Cover—Diaphragm	968	223765	Cover—Air Cleaner
435	93141	Screw—Diaphragm Cover	969	490073	Screw—Cover Mtg.
441	224240	Bracket—Oil Fill	971	94018	Screw—Air Cleaner
467	280715	Knob—Control	987	398970	Seal—Throttle Shaft
523	492249	Cap—Oil Fill	995	223887	Bracket—Link
524	271485	Gasket—Oil Fill Cap	1012	490507	Link—Retainer
525	280508	Nipple—Oil Fill	1016	490817	Spacer
526	94409	Screw—Tank Bracket Mounting Sem	1019	491100	Decal (Label) Kit
527	223786	Clamp—Breather Tube			
528	231550	Tube—Breather			
529	67838	Grommet—Breather Tube			

*Included in Gasket Set—
Part No. 397145.

**SPARK ARRESTING MUFFLER ASSEMBLY 392390
(Optional Equipment)**

Consists of the following:
392154 Screen (1 required)
223372 Deflector (1 required)
93705 Screw (4 required)

SEARS **OWNER'S** **MANUAL**

MODEL NOS.
247.797852
247.797853

HOW TO ORDER **REPAIR PARTS**

CRAFTSMAN®

5 HORSEPOWER **3 CUTTING STAGE** **MULCHING AND BAGGING** **CHIPPER-SHREDDER**

Each chipper-shredder has its own model number. Each engine has its own model number.

The model number for your chipper-shredder will be found on a label attached to the frame.

The model number for the engine will be found on the blower housing of the engine.

All parts listed herein may be ordered through Sears, Roebuck and Co. Service Centers and most Retail Stores.

WHEN ORDERING REPAIR PARTS, ALWAYS GIVE THE FOLLOWING INFORMATION:

- * **PRODUCT - "5 H.P. Chipper-Shredder"**
- * **MODEL NUMBER - 247.797852**
247.797853
- * **ENGINE MODEL NO. - 130212-3250-01**
- * **PART NUMBER**
- * **PART DESCRIPTION**

Your Sears merchandise has added value when you consider that Sears has service units nationwide staffed with Sears trained technicians...professional technicians specifically trained on Sears products, having the parts, tools and the equipment to insure that we meet our pledge to you...we service what we sell."

SEARS, ROEBUCK AND CO., Chicago, IL 60684 U.S.A.

Free Manuals Download Website

<http://myh66.com>

<http://usermanuals.us>

<http://www.somanuals.com>

<http://www.4manuals.cc>

<http://www.manual-lib.com>

<http://www.404manual.com>

<http://www.luxmanual.com>

<http://aubethermostatmanual.com>

Golf course search by state

<http://golfingnear.com>

Email search by domain

<http://emailbydomain.com>

Auto manuals search

<http://auto.somanuals.com>

TV manuals search

<http://tv.somanuals.com>