

SAVE THIS MANUAL
FOR FUTURE REFERENCE

SEARS

owners
manual

MODEL NO.
113.213832

DRILL PRESS WITH
1/4 HP MOTOR

Serial
Number

Model and serial number
may be found at the rear of
the head.

You should record both
model and serial number in
a safe place for future use.

CAUTION:
Read GENERAL
and ADDITIONAL
SAFETY
INSTRUCTIONS
carefully

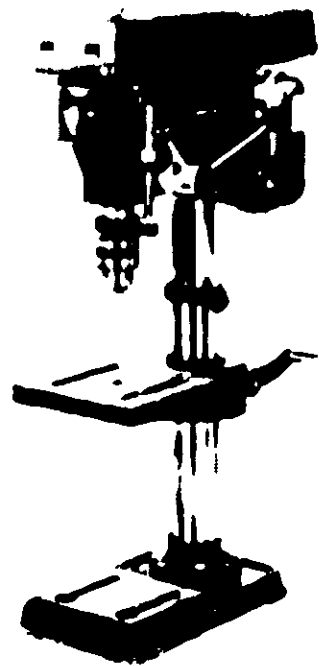

CRAFTSMAN.

MOTORIZED 10 INCH BENCH MODEL DRILL PRESS

- assembly
- operating
- repair parts

FULL ONE YEAR WARRANTY ON CRAFTSMAN DRILL PRESS

If within one year from the date of purchase this Craftsman Drill Press fails due to a defect in material or workmanship Sears will repair it, free of charge.

WARRANTY SERVICE IS AVAILABLE BY RETURNING THE CRAFTSMAN DRILL PRESS TO THE NEAREST SEARS RETAIL CATALOG STORE OR SERVICE CENTER DEPARTMENT IN THE UNITED STATES.

THIS WARRANTY APPLIES ONLY WHILE THIS PRODUCT IS IN USE IN THE UNITED STATES.

This warranty gives you specific legal rights and you may also have other rights which vary from state to state.

SEARS ROEBUCK AND CO. Sears Tower BSC 41-3 Chicago IL 60684

general safety instructions for power tools

- 1 KNOW YOUR POWER TOOL**
Read and understand the warning instructions and safety precautions for all power tools. Do not use a power tool unless you are familiar with its operation.
- 2 GROUND ALL TOOLS**
To prevent electric shock, ground all power tools. Do not use power tools unless they are properly grounded. Do not use power tools unless they are properly grounded.
- 3 KEEP GUARDS IN PLACE**
Always use the guard and other safety devices provided with the tool.
- 4 REMOVE ADJUSTING KEYS AND WRENCHES**
Form a habit of looking to see that keys and adjusting wrenches are removed from the tool before trying to start it.
- 5 KEEP WORK AREA CLEAN**
Cluttered areas and benches invite accidents. Floor must not be slippery due to wax or sawdust.
- 6 AVOID DANGEROUS ENVIRONMENT**
Don't use power tools in damp or wet locations or expose them to rain. Keep work area well lighted. Provide adequate surrounding work space.
- 7 KEEP CHILDREN AWAY**
All visitors should be kept a safe distance from work area.
- 8 MAKE WORKSHOP KID-PROOF**
Use padlocks, master switches, or by removing starter keys.
- 9 DON'T FORCE TOOL**
It will do the job better and safer at the rate for which it was designed.
- 10 USE RIGHT TOOL**
Don't force tool or attachment to do a job it was not designed for.
- 11 WEAR PROPER APPAREL**
Do not wear loose clothing, gloves, neckties or jewelry (rings, wrist watches) to get caught in moving parts. Nonslip footwear is recommended. Wear protective hair covering to contain long hair. Roll long sleeves above the elbow.
- 12 USE SAFETY GOGGLES (Head Protection)**
Wear safety goggles or safety glasses with A-501 Z87 rating. Use eye protection when you have a chance of being struck by a flying object. Safety glasses with A-501 rating protect against eye injury from flying objects.
- 13 SECURE WORK**
Use clamps or other means to hold work when possible. It is safer than holding it and keeps both hands free.
- 14 DON'T OVERREACH**
Keep proper footing and balance at all times.
- 15 MAINTAIN TOOLS WITH CARE**
Keep tools sharp and clean for best and safest performance. Follow instructions for lubricating and changing accessories.
- 16 DISCONNECT TOOLS**
Before servicing, when changing accessories such as blades, bits, cutters, etc.
- 17 AVOID ACCIDENTAL STARTING**
Make sure switch is in OFF position before plugging in.
- 18 USE RECOMMENDED ACCESSORIES**
Consult the owner's manual for recommended accessories. Follow the instructions that accompany the accessories. The use of improper accessories may cause hazards.
- 19 NEVER STAND ON TOOL**
Serious injury could occur if the tool is tipped or if the cutting tool is accidentally contacted.
Do not store materials above or near the tool such that it is necessary to stand on the tool to reach them.
- 20 CHECK DAMAGED PARTS**
Before further use of the tool, a guard or other part that is damaged should be carefully checked to ensure that it will operate properly and perform its intended function. Check for alignment of moving parts, binding of moving parts, breakage of parts, mounting, and any other conditions that may affect its operation. A guard or other part that is damaged should be properly repaired or replaced.

21 DIRECTION OF FEED

22 NEVER LEAVE TOOL RUNNING UNATTENDED

additional safety instructions for drill presses

WARNING For your own safety do not attempt to operate your drill press until it is completely assembled and installed according to the instructions and until you have read and understand the following

	Page
1 General Safety Instructions for Power Tools	2
2 Getting to Know Your Drill Press	12
3 Basic Drill Press Operation	16
4 Adjustments	18
5 Maintenance	19

6 Stability of Drill Press

The drill press should be used on a flat, level surface. The drill press should be clamped to a sturdy work surface. The drill press should be used on a work surface that is at least 1/2 inch thick and is capable of supporting the weight of the drill press. The drill press should be used on a work surface that is at least 1/2 inch thick and is capable of supporting the weight of the drill press.

7 Location

The drill press should be used on a flat, level surface. The drill press should be clamped to a sturdy work surface. The drill press should be used on a work surface that is at least 1/2 inch thick and is capable of supporting the weight of the drill press.

8 Kickback

A kickback may occur when the workpiece is suddenly thrown in the OPPOSITE DIRECTION OF THE DIRECTION OF FEED. THIS CAN CAUSE SERIOUS INJURY. Kickbacks are most commonly caused by use of a press that is NOT tied to a work surface.

9 Protection Eyes Hands Face Ears and Body
WARNING To avoid being pulled into the spinning tool -

- 1 Do NOT wear
 - gloves
 - necktie
 - loose clothing
 - jewelry
- 2 Tie back long hair

- a. If any part of a drill press (including main housing) has been damaged or broken, do not use it as the motor switch or other operating controls a safety device or the power cord. Have a qualified person operating immediately into the particular part properly repaired or replaced.
- b. Never place your fingers in a position where they could contact the drill or other cutting tool if the workpiece should unexpectedly shift or your hand should slip.
- c. To avoid injury from parts thrown by the spring follow instructions exactly as given and always in adjusting spring tension of quill.

The drill press should be used on a flat, level surface. The drill press should be clamped to a sturdy work surface. The drill press should be used on a work surface that is at least 1/2 inch thick and is capable of supporting the weight of the drill press.

The drill press should be used on a flat, level surface. The drill press should be clamped to a sturdy work surface. The drill press should be used on a work surface that is at least 1/2 inch thick and is capable of supporting the weight of the drill press.

The drill press should be used on a flat, level surface. The drill press should be clamped to a sturdy work surface. The drill press should be used on a work surface that is at least 1/2 inch thick and is capable of supporting the weight of the drill press.

The drill press should be used on a flat, level surface. The drill press should be clamped to a sturdy work surface. The drill press should be used on a work surface that is at least 1/2 inch thick and is capable of supporting the weight of the drill press.

The drill press should be used on a flat, level surface. The drill press should be clamped to a sturdy work surface. The drill press should be used on a work surface that is at least 1/2 inch thick and is capable of supporting the weight of the drill press.

10 Use only accessories designed for this drill press to avoid serious injury from thrown broken parts or work pieces

- a. Holesaws must NEVER be operated on this drill press at a speed greater than 400 RPM.
- b. Drum sanders must NEVER be operated on this drill press at a speed greater than 1800 RPM.

additional safety instructions for drill presses

- 10 Do not install or use any drill that is not the same length as the drill bit to which it is attached. They are not fully bent to wait for break.
- 11 Do not use wire wheels, sanders, paper or files on any cutter or cutting tool on this drill press.
- 11 Note and Follow the Safety Warnings and Instructions that Appear on the Panel on the Left Side of the Head

DANGER

- FOR YOUR OWN SAFETY**
- 1 READ AND UNDERSTAND OWNERS MANUAL BEFORE OPERATING MACHINE
 - 2 WEAR SAFETY GOGGLES
 - 3 DO NOT WEAR GLOVES NECKTIE OR LOOSE CLOTHING TIE BACK LONG HAIR
 - 4 SECURELY CLAMP WORK TO TABLE IF IT IS TOO SHORT TO CONTACT THE COLUMN WHEN IN OPERATING POSITION
 - 5 USE RECOMMENDED SPEED FOR DRILL ACCESSORY AND WORKPIECE MATERIAL
 - 6 SECURELY LOCK HEAD AND SUPPORT TO COLUMN ARM TO SUPPORT AND TABLE TO ARM BEFORE OPERATING DRILL PRESS
 - 7 USE ONLY RECOMMENDED ACCESSORIES

12 This Drill Press has 4 speed settings to the low

48 RPM
310 RPM
1700 RPM
3000 RPM

(See right side of Head for speed adjustment of belt on pulleys)

13 Think Safety Safety is a combination of operator common sense and alertness at all times when the drill press is being used

WARNING Do not allow familiarity (gained from frequent use of your drill press) to become commonplace. Always remember that a careless fraction of a second is sufficient to inflict severe injury.

The operation of any power tool can result in large objects being thrown into the eyes, which can result in severe eye damage. Always wear safety goggles conforming with ANSI Z87.1, shown on this page, before using any power tool. Operating safety goggles are available at most retail stores.



unpacking and checking contents

CONTENTS	PAGE	CONTENTS	PAGE
General Safety Instructions for Power Tools	2	Removing the Chuck	15
Additional Safety Instructions for Drill Press	3	Drilling to Depth	15
Unpacking and Checking Contents	5	Depth Scale	15
Table of Loose Parts	5	Basic Drill Press Operation	16
Motor Specifications and Electrical Requirements	6	Installing Drills	16
Assembly	7	Positioning Table and Workpiece	17
Assembly of Base Column	7	Tilting Table	17
Installing the Table Support	7	Hole Location	18
Assembly & Hardware	7	Feeding	18
Installing the Head	8	Adjustments	18
Installing Feed Handles	9	Quill Return Spring	18
Installing the Chuck	9	Maintenance	19
Tensioning Belt	10	Lubrication	19
Adjusting the Table Square to Head	11	Recommended Accessories	19
Adjusting the Pointer	11	Double Shooting	20
Getting to Know Your Drill Press	12	Repair Parts	21

UNPACKING AND CHECKING CONTENTS

Model No. 113-213832 is shipped complete in one carton and includes a 1/4 HP 1725 RPM motor.

Separate all parts from packing materials and check each item with the Table of Loose Parts to make certain all items are accounted for before disassembling any packing material.

WARNING For your own safety. If any parts are missing, do not attempt to assemble the drill press plug in the power cord or turn the switch on until the missing parts are obtained and installed correctly.

Read the instructions carefully before using the power tool. Do not use the power tool for any purpose other than that intended.

WARNING To avoid fire or toxic reaction, never use gasoline, naphtha or similar highly volatile solvents.

Apply the instructions to the power tool. Do not use the power tool for any purpose other than that intended.

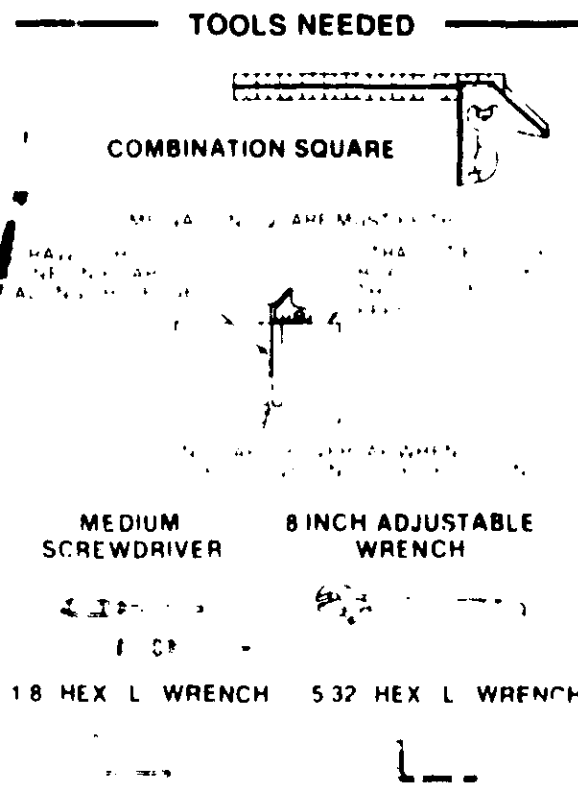

TABLES OF LOOSE PARTS

Item	Description	Qty
A	Column Assembly	1
B	Head Assembly	1
C	Table Support Assembly	1
D	Base	1
E	Owners Manual	1
Box of Miscellaneous Small Parts (Part # 71308) Consisting of the Following:		
	Chuck	1
	Feet Hardware	1
	Support Link	1
	Chuck Key 13MM	1
	Table Crank Assembly	1
	*Screw Pan Hd 10-32x1/4	1
	*Pin	1
	*Bolt Hex Hd 3/8-16x1/2	4
	*Lockwasher 3/8	4
	*Hex Soc. Set Screw 5/16-18x1/2	2
	*Switch Key	1
	*Screw Flat Hd 10-32x7/8	1
	*Knob Belt Guard	1
	*Screw Pan Head 1/4-20x1/2	1

* Parts Contained in Loose Parts Bag Part No. 71308

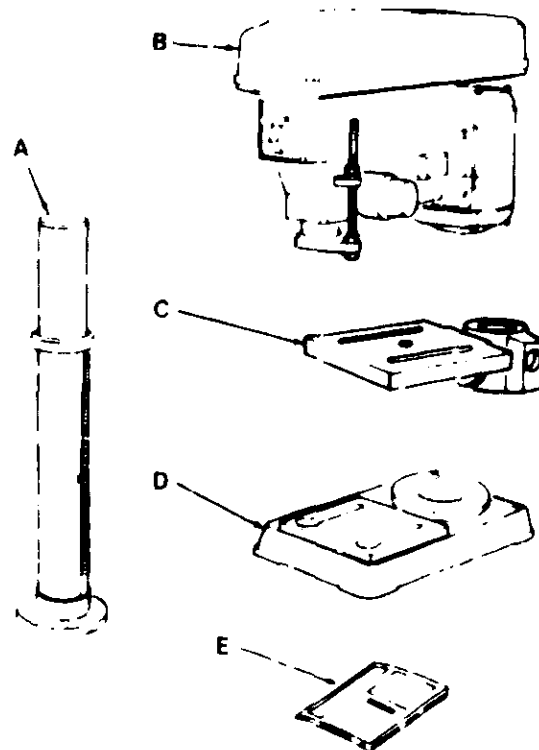

motor specifications and electrical requirements

MOTOR SPECIFICATIONS

This drill press is designed to use a 1725 RPM motor only. Do not use any motor that runs faster than 1725 RPM. It is wired for operation on 110-120 volts, 60 Hz alternating current.

WARNING To avoid injury from unexpected start-up, do not use blower or washing machine motors or any motor with an automatic reset overload protector.

CONNECTING TO POWER SOURCE OUTLET

The plug here must be grounded when used to protect the operator from electric shock.

Plug power cord into a 110-120V properly grounded outlet protected by a 15 amp circuit breaker or 20 amp Circuit Breaker fuse in the main panel.

NOT ALL OUTLETS ARE PROPERLY GROUNDED. IF YOU ARE NOT SURE THAT YOUR OUTLET AS PICTURED BELOW IS PROPERLY GROUNDED, HAVE IT CHECKED BY A QUALIFIED ELECTRICIAN.

WARNING Do not permit fingers to touch the terminals of plugs when installing or removing the plug to or from the outlet.

WARNING If not properly grounded this power tool can incur the potential hazard of electrical shock, particularly when used in damp locations in proximity to plumbing. If an electrical shock occurs there is the potential of a secondary hazard such as your hands contacting the cutting tool.

If power cord is worn or cut, or damaged in any way, have it replaced immediately to avoid shock or fire hazard.

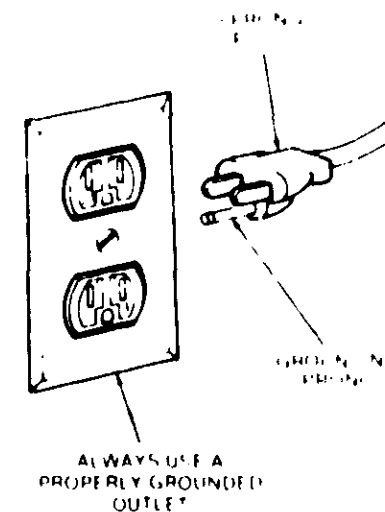

If your unit is for use on less than 150 volts, it has a plug that looks like the above.

This power tool is equipped with a 3 conductor cord and grounding type plug which has a grounding prong approved by Underwriters Laboratories and the Canadian Standards Association. The ground cord has a green jacket and is attached to the tool housing at one end and to the ground prong in the attachment plug at the other end.

This plug requires a mating 3 conductor grounded type outlet as shown.

If the outlet you are planning to use for this power tool is of the two prong type, DO NOT REMOVE OR ALTER THE GROUNDING PRONG IN ANY MANNER. Use an adapter as shown and always connect the grounding lug to known ground.

It is recommended that you have a qualified electrician replace the TWO prong outlet with a properly grounded THREE prong outlet.

An adapter as shown below may be used to connect this plug to a 2 prong receptacle.

WARNING The green grounding lug extending from the adapter must be connected to a permanent ground such as to a properly grounded outlet box.

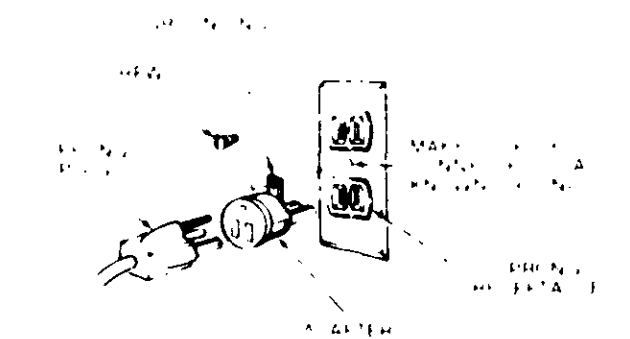

NOTE The adapter illustrated is for use only if you already have a properly grounded 2 prong receptacle. Adapter is not allowed in Canada by the Canadian Electrical Code.

The use of any extension cord will cause some loss of power. To keep this to a minimum and to prevent overheating and motor burn out, use the table below to determine the minimum wire size (A.W.G.) extension cord. Use only 3 wire extension cords which have 3 prong grounding type plugs and 3 pole receptacles which accept the tool's plug.

Extension Cord Length	Wire Size A.W.G.
Up to 100 Ft	16
100-200 Ft	14
200-400 Ft	10

assembly

WARNING For your own safety, never connect plug to power source outlet until all assembly steps are completed

ASSEMBLY OF BASE COLUMN

- 1 Position base on floor
- 2 Remove protective sleeve from column tube and discard. Place column assembly on base, and align holes in column support with holes in base
- 3 Locate four (4) 3/8 16x1 1/2 bolts and four (4) 3/8 lock washers among loose parts bag
- 4 Install a lock washer and bolt in each hole through column support and base, and tighten with adjustable wrench

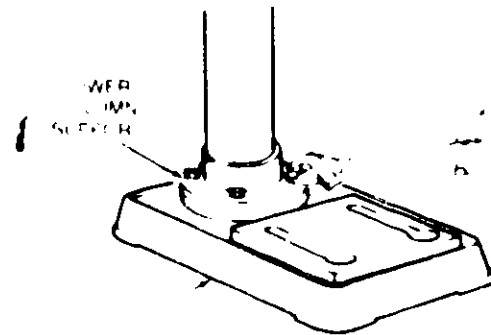

INSTALLATION OF TABLE SUPPORT ASSEMBLY AND HARDWARE

- 1 Install a set screw in column collar with 1/8 HEX L wrench and remove collar and rack from column

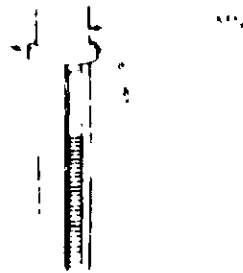

- 2 With long smooth end of rack pointing upward, slide rack down through large round opening in table support. Engage rack in gear mechanism found inside opening of table support
- 3 While holding rack and table support in an engaged position, slide both down over column. Slide rack down column until rack is positioned against lower column support

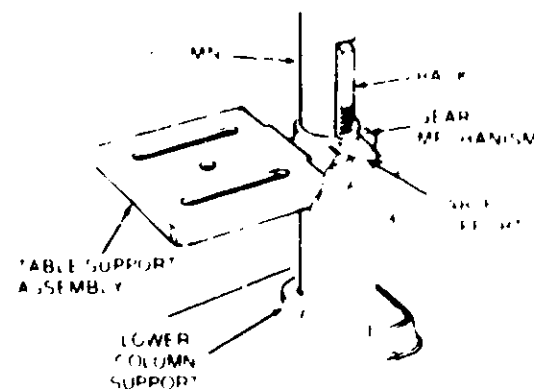

- 4 Replace column collar and position it over rack. Tighten setscrew in collar with 1/8 HEX L wrench. Collar should sit loosely over rack and should not be angled on the column. Only tighten setscrew enough to keep collar in place. Rack should still slide freely in collar

CAUTION: To avoid column tube or collar damage, do not over tighten setscrew.

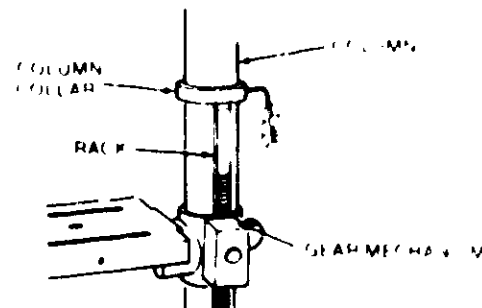

7

assembly

- 5 Locate table crank assembly and support lock among loose parts
- 6 Install table crank assembly (as illustrated) onto shaft extending out of table support. Tighten set screw against flat side of shaft using 1/8 HEX L wrench
- 7 Install support lock from left side into table support and tighten by hand
- 8 Table crank handle should turn freely when raising/lowering table. If adjustment is needed, loosen jam nut then with a screwdriver loosen bolt in handle until there is play between jam nut and handle. Tighten jam nut securely while holding handle and with screwdriver

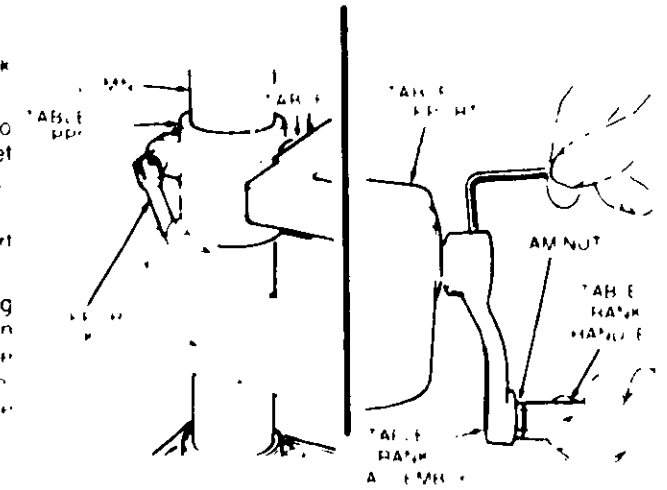

- 9 Loosen support lock and raise table support by turning table crank clockwise until support is at a working height. Tighten support lock

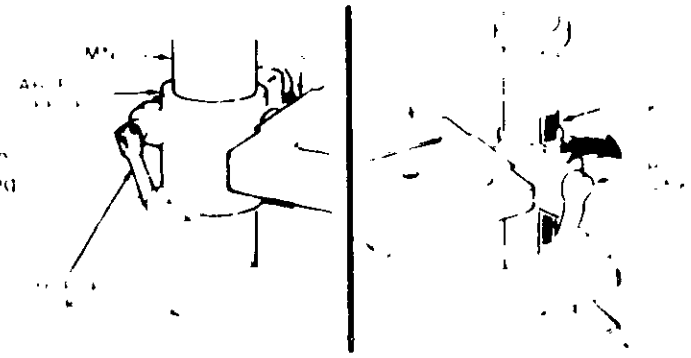

INSTALLING THE HEAD

CAUTION The head assembly weighs about 45 pounds. Carefully lift head

- 1 Remove protective bag from head assembly and discard. Carefully lift head above column tube and slide it onto column making sure head slides down over column as far as possible. Align head with table and base

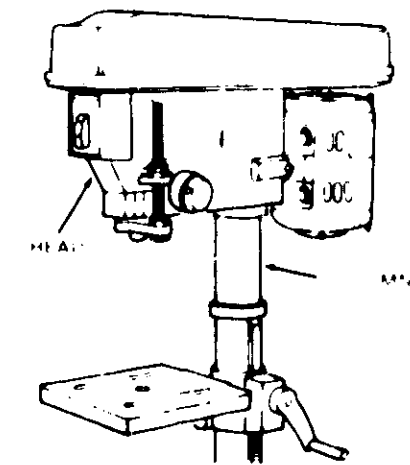

- 2 Locate two (2) 5/16 18x1 1/2 set screws among loose parts bag
- 3 Install one set screw on each side of head to lock head into position, and tighten with 5/32 HEX L wrench

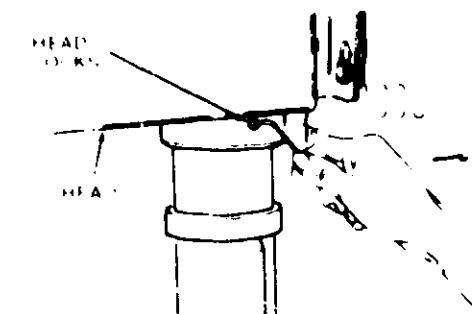

8

INSTALLING FEED HANDLES

1. Locate three (3) feed handles among loose parts.
2. Screw the feed handles into the threaded holes in the hub and tighten.

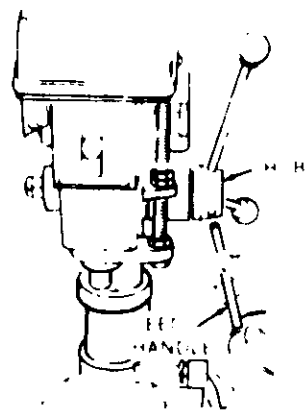

3. Locate one (1) 10-32x1/4 pan head screw and one (1) pointer among loose parts bag.
4. Install screw through pointer and into table support. Tighten screw with screwdriver.

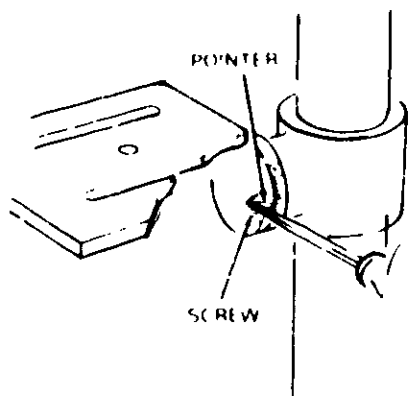

INSTALLING THE CHUCK

1. Locate chuck and one (1) 10-32x7/8 flat head screw among loose parts.
2. Clean out the TAPERED HOLE in the chuck as illustrated. Clean the spindle nose with a clean cloth. Make sure there are no foreign particles sticking to the surfaces. The slightest piece of dirt on the spindle nose or in the chuck will prevent the chuck from seating properly. This will cause the drill to wobble.

NOTE: If TAPERED HOLE in the chuck is extremely dirty, use a cleaning solvent on the clean cloth.

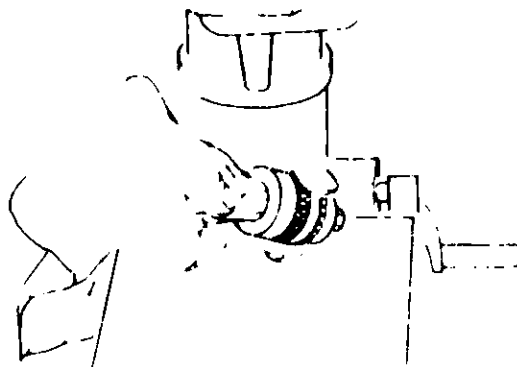

3. Push the chuck up on the spindle nose as far as it will go.
4. Lightly tap the nose of the chuck with a piece of wood to insure proper seating of the chuck on the spindle.

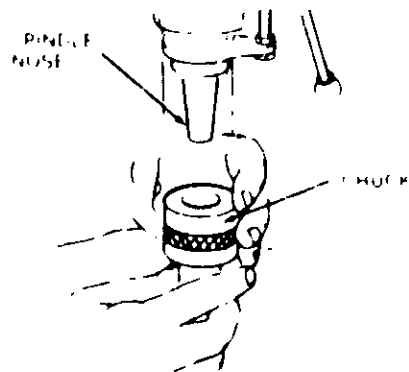

9

assembly

5. Open the jaws of the chuck as wide as they will go by turning the chuck sleeve.
6. Insert screw inside chuck and tighten onto spindle nose with screwdriver.

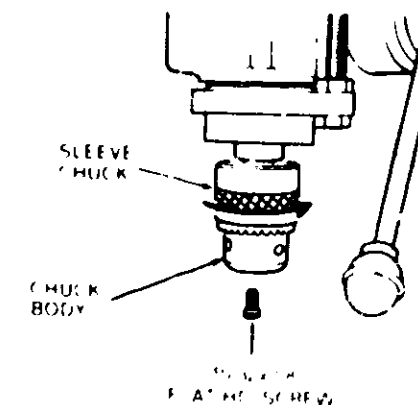

INSTALLATION OF BELT GUARD KNOB

1. Locate knob and 1/4 20x3/8 pan head screw among loose parts bag. Install screw in hole located in belt guard and attach knob turning until tight.

TENSIONING BELT

NOTE: The Drill Press is shipped with the belt installed but it should be properly tensioned before use.

1. Lift belt guard from right side and leave opened on hinge.
2. Release Belt Tension Lock Handles, located on each side of Drill Press head.

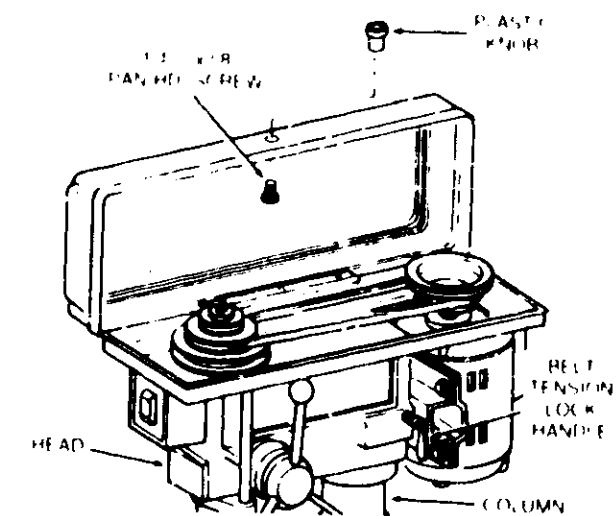

3. Choose speed for drilling operation and move belt to correct position for desired speed.

NOTE: Refer to chart on side of Drill Press for Recommended Drilling Speeds.



4. Adjust belt tension by pushing against motor mount moving motor toward rear (see illustration).
5. Tighten Belt Tension Lock Handles.

NOTE: Belt SHOULD deflect approximately 1/2" by thumb pressure at mid point of belt between pulleys.

6. Close belt guard.
7. If belt slips while drilling, readjust belt tension.

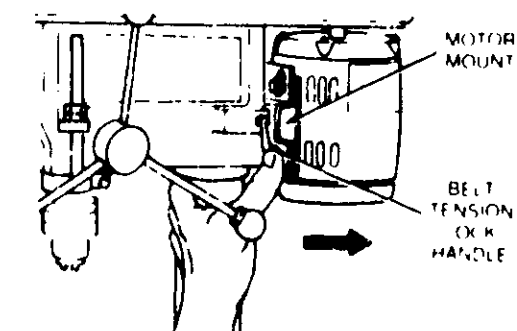

10

getting to know your drill press

ADJUSTING THE TABLE SQUARE TO HEAD

NOTE: The combination square must be checked for squareness after unpacking and checked for accuracy by the method.

1. Insert a precision round steel rod approximately 1/2" long in the inter-chuck and tighten.
2. With table raised to working height, adjust the combination square to be square to the table.

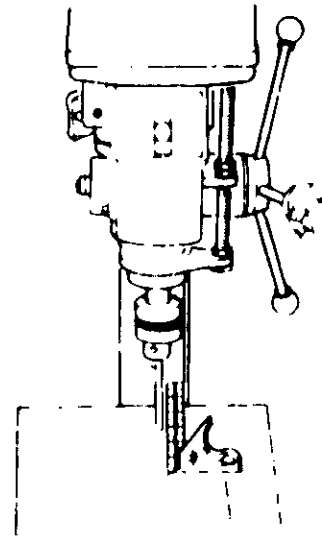

3. Mark a square on the side of the rod with a sharp pencil. Use a 1/8" hex key to loosen the table head lock nut with the table raised. Then adjust the table to be square to the rod.

4. Adjust the square to the rod by the table adjustment.
5. Retighten table head lock nut.
6. Retighten set screw.

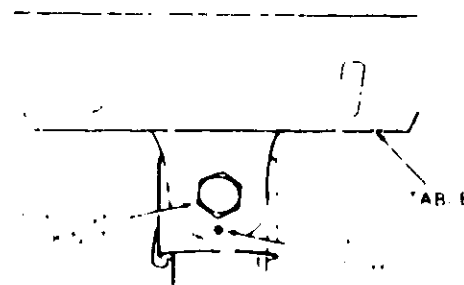

ADJUSTING POINTER

1. With the table squared to the head, the table bevel pointer should be adjusted.
2. Loosen screw in pointer with screw driver, and move pointer to 0 position on scale. Retighten screw.

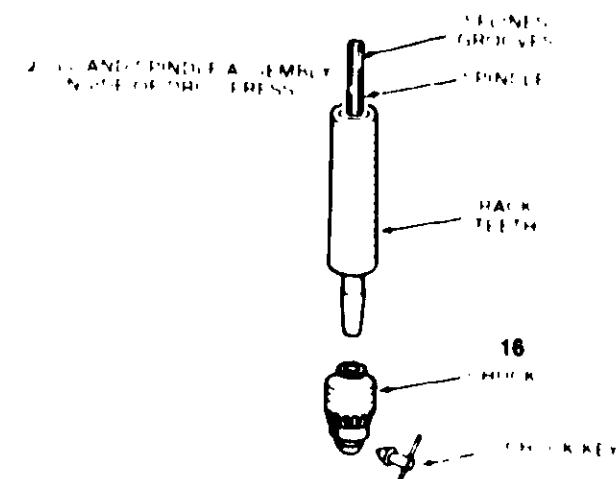
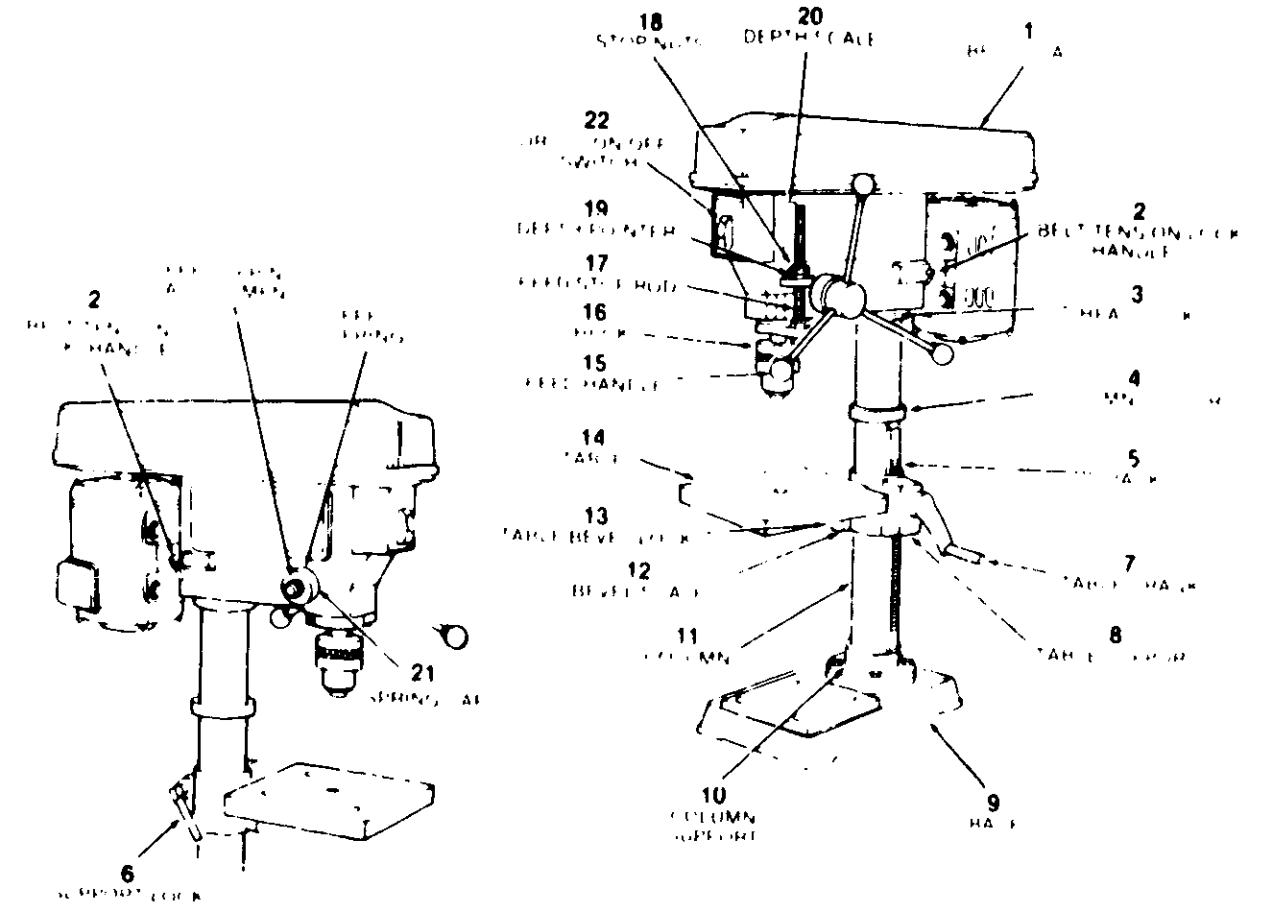
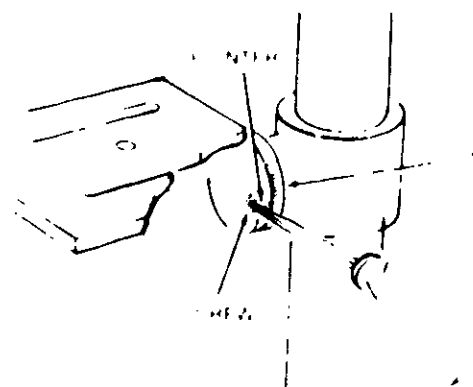

This Drill Press has 4 speeds as listed below

480 RPM
930 RPM
1750 RPM
3000 RPM

See right side of Head for specific placement of belts on pulleys

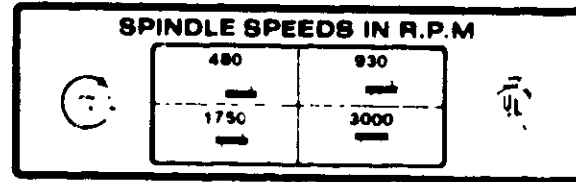

- 1 **BELT GUARD** — Covers pulleys and belt during operation of drill press.
- 2 **BELT TENSION LOCK HANDLES** — Tightening handles to lock motor belt and support belt for proper belt drive and tension.
- 3 **HEAD LOCK** — Locks the head to the column. Always have it locked in place when operating the drill press.
- 4 **COLUMN COLLAR** — Holds the rack to the column. Rack remains movable in order to permit table support movements.
- 5 **RACK** — Combines with gear mechanism to provide easy elevation of table by hand operated table crank.
- 6 **SUPPORT LOCK** — Tightening locks table support to column. Always have it locked in place when operating the Drill Press.
- 7 **TABLE CRANK** — Turn clockwise to elevate table. Support lock must be released before rotating crank.
- 8 **TABLE SUPPORT** — Rides on column to support table.
- 9 **BASE** — Supports Drill Press. For additional stability, holes are provided in base to bolt Drill Press to bench. (See Additional Safety Instructions for Drill Presses)
- 10 **COLUMN SUPPORT** — Supports column, quill, rack, and provides mounting holes for column to base.

- 11 **COLUMN** — Connects to table and base in order to permit easy alignment and movement.
- 12 **BEVEL SCALE** — Shows angle table is tilted for heavy operation. Scale is mounted on table support.
- 13 **TABLE BEVEL LOCK** — Locks the table in any position from 0-45.
- 14 **TABLE** — Provides working surface to support workpiece.
- 15 **FEED HANDLE** — For moving the quill up or down. One or two may be removed if necessary whenever the workpiece is of such unusual shape that it interferes with the handles.
- 16 **CHUCK** — Holds drill bit or other recommended accessory to perform desired operations.
- 17 **FEED STOP ROD** — Holds stop nuts for drilling to specific depths.
- 18 **STOP NUTS** — Limits the downward movement of the quill at any desired point within its travel and prevents the pointer from moving upward.
- 19 **DEPTH POINTER** — Indicates drilling depth and is located between stop nuts.
- 20 **DEPTH SCALE** — Shows depth of hole being drilled in inches and millimeters.
- 21 **SPRING CAP** — Provides means to adjust quill spring tension.

getting to know your drill press

22 **ON-OFF SWITCH** — Has locking feature. THIS FEATURE IS INTENDED TO PREVENT UNAUTHORIZED AND POSSIBLE HAZARDOUS USE BY CHILDREN AND OTHERS.

Insert KEY into switch.

NOTE — Key is made of yellow plastic.

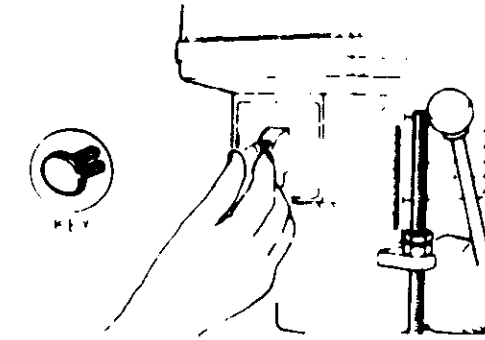

To turn drill ON — Push lever in. Hold finger under switch lever and pull.

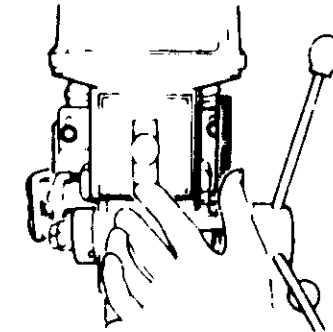

To turn drill OFF — Push lever in. In an emergency, if the drill bit BINDS or STALLS or tends to tear the workpiece loose, you can QUICKLY turn the drill OFF by hitting the switch with the palm of your hand.

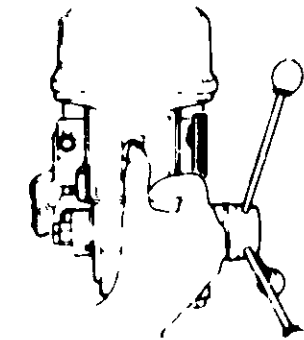

To lock switch in OFF position — hold switch IN with one hand. REMOVE key with other hand.

WARNING For your own safety, always lock the switch "OFF" when Drill Press is not in use. Remove key and keep it in a safe place, also.

In the event of a power failure (all of your lights go out) or blown fuse or tripping circuit breaker, turn switch off. Lock it and remove the key. This will prevent the Drill Press from starting up again when the power comes back on.

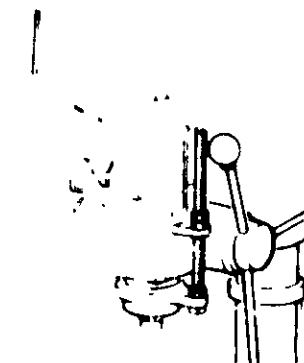

CHUCK KEY — It is a self-ejecting chuck key which will pop out of the chuck when you stop it. The action is designed to help prevent the slipping of the chuck key from the chuck when power is turned ON. Do not use any other key and do not substitute a new one if damaged or lost.

BELT TENSION — Refer to page for Assembly and Tightening Belt Page 1.

DRILLING SPEED — Can be changed by placing the belt on one of the STEPS (grooves) on the pulleys. See Spindle Speed Chart on page 1 for details.

To select the approximate drilling speed, refer to the chart on the left side of the Spindle Speed Chart.

REMOVING THE CHUCK

1. Open jaws of Chuck with Chuck Key and pull Chuck away.
2. Insert Chuck Key into Chuck Key Hole.
3. Carefully tap Chuck with the end of the Chuck Key to bring Chuck to the right hand position. Do not use force.
4. Slide Chuck onto the Table.

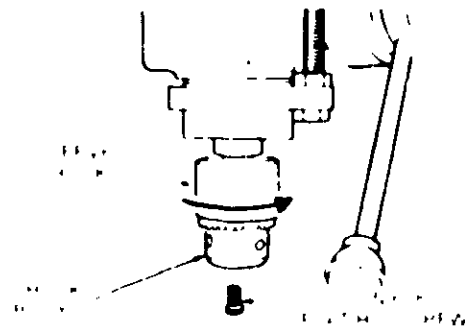

DRILLING TO DEPTH

To drill a BLIND hole all the way through to a given depth can be done in 4 ways.

1. Mark the depth of the hole on the side of the work piece.
2. With the switch OFF bring the drill down until the TIP of the drill is even with the Mark.
3. Spin the lower nut down to contact the depth stop lug on the Head.
4. Move the POINTER all the way down.
5. Spin the upper nut down and tighten against the pointer.

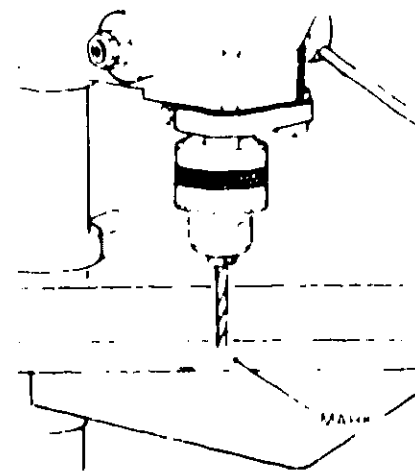

ANOTHER WAY — DEPTH SCALE

1. With the switch OFF bring the drill down until the TIP touches the TOP of the WORKPIECE.
2. Adjust the nuts so the Pointer is set to the desired DEPTH. TIGHTEN the UPPER NUT against the Pointer. For example, if you want to drill a hole one inch deep, set the pointer at the one inch mark on the SCALE.

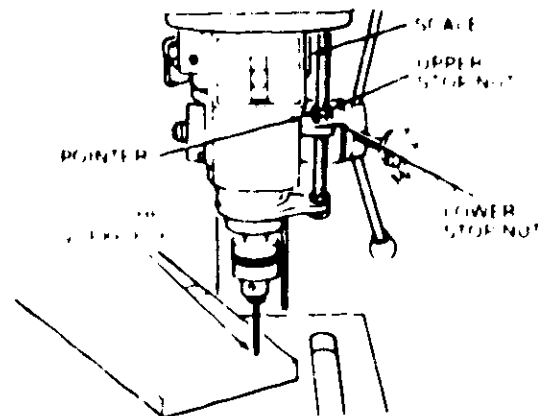

basic drill press operation

Follow the following instructions for operating your drill press to get the best results and to minimize the risk of personal injury.

WARNING For your own safety always observe the safety precautions here and on pages 2, 3 and 4.

1 Protection Eyes, Hands, Face, Ears and Body

WARNING To avoid being pulled into the spinning tool —

- 1 Do NOT wear
 - gloves
 - necktie
 - loose clothing
 - jewelry
- 2 Tie back long hair

- a. If any part of your body is in the spinning machine, turning the motor Switch OFF to stop the tool. If you get caught in the machine while the motor is running, stop the motor immediately by turning the power OFF. Do not attempt to free yourself or the part or part properly repaired there.
- b. Never place your fingers in a position where they could contact the drill or other cutting tool if the workpiece should unexpectedly shift or your hand should slip. To avoid injury from parts thrown by the spinning tool, follow instruction exactly as given and shown in adjusting spring tension of pin.
- c. To prevent the workpiece from being torn from your hands, spinning of the tool, shattering the tool or being thrown, always properly support your work so it won't shift or bind on the tool.

A ways position BACKUP MATERIAL use beneath the workpiece to contact the left side of the column.

Whenever possible, position the WORKPIECE to contact the left side of the column. If it is too short or the table is tilted, clamp securely to the table. Use table slots or clamping edge around the outside edge of the table.

A drill press VICE must always be fastened to the table.

Never perform any operation FREE HAND (hand holding workpiece) rather than supporting it on the table, except when pushing.

Securely lock Head and Support to Column, Table Arm to Support, and Table to Table Arm before operating the press.

Never move the Head or Table when the tool is running.

Before starting the operation, plug the motor switch to make sure the drill or other cutting tool does not have excessive runout (wobble) or cause vibration.

If a workpiece overhangs the table such that it will fall or tip if not held, clamp it to the table or provide auxiliary support.

Use fixtures for unusual operations. Use adequately held, guide and position workpiece.

Use the SPINDLE SPEED recommended for the specific operation and workpiece material. Check the page on the left side of the head for drilling information for accessories; refer to the instructions provided with the accessories.

- a. Never climb on the drill press. Table it could break or pull the entire drill press down on you.
- b. Turn the motor Switch OFF and put away the Switch Key when leaving the drill press.
- c. To avoid injury from thrown work or tool contact, do NOT perform layout, assembly or setup work on the table while the cutting tool is rotating.

2 Use only accessories designed for this drill press to avoid serious injury from thrown broken parts or work pieces

- a. Holesaws must NEVER be operated on this drill press at a speed greater than 400 RPM.
- b. Drum sanders must NEVER be operated on this drill press at a speed greater than 1800 RPM. Do not install or use any drill that exceeds 7 in length or extends 6 in below the chuck jaws. They can suddenly bend outward or break.
- c. Do not use wire wheels, router bits, shaper cutters, circle (fly) cutters or rotary planers on the drill press.

INSTALLING DRILLS

Insert drill into chuck far enough to obtain maximum GRIPPING of the CHUCK JAWS — the jaws are approx. 1 in long. When using a small drill, do not insert it so far that the jaws touch the flutes (spiral grooves) of the drill.

Make sure that the drill is CENTERED in the chuck before tightening the chuck with the key.

Tighten the drill sufficiently so that it does not slip while drilling.

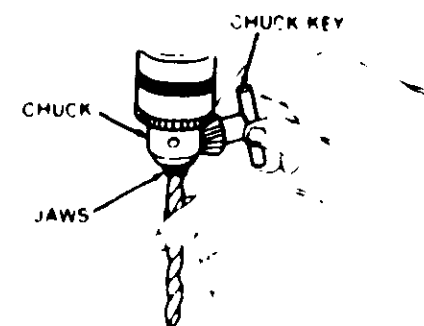

basic drill press operation

POSITIONING TABLE AND WORKPIECE

Lock the table in the position or a position so that the top of the table is just 1/16" above the top of the work piece.

A way to keep a piece of BACKUP MATERIAL will not prevent it from the table underneath the workpiece. This will prevent the workpiece from falling through the underside of the workpiece as the drill bit penetrates. To keep the backup material from slipping, use a clamp to hold it against the left side of the column.

WARNING To prevent the workpiece or the backup material from being torn from your hand while drilling position them against the left side of the column. If the workpiece or the backup material are not long enough to reach the column clamp them to the table. Failure to do this could result in personal injury.

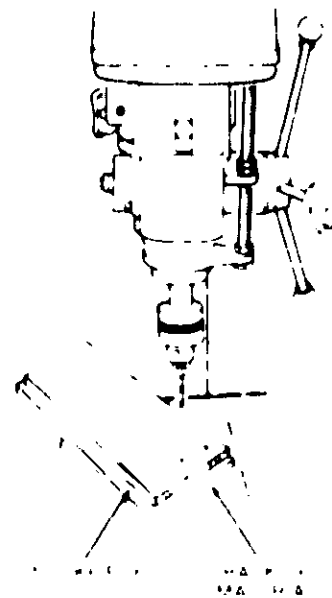

basic drill press operation

WARNING To avoid injury from spinning work or tool breakage, always clamp workpiece and backup material securely to table before operating Drill Press with the table tilted.

Turn the feed hand crank clockwise to lower the quill. Turn the feed hand crank counter-clockwise to raise the quill. Turn the feed hand crank clockwise to lower the quill.

HOLE LOCATION

Make sure that the workpiece is aligned with the quill. The quill should be centered on the workpiece.

Before turning the switch ON bring the quill down to the workpiece and set it up with the hole location.

FEEDING

Push down on the feed handles with any enough effort to push the quill down.

Feeding TOO SLOWLY will cause the quill to burn. Feeding TOO RAPIDLY will stop the motor. Use the motor to push the quill down. The workpiece should be BREAKED THROUGH.

Use the vise to hold the workpiece. The vise must be clamped or bolted to the table to avoid injury from spinning work and vise or tool breakage.

WARNING The vise must be clamped or bolted to the table to avoid injury from spinning work and vise or tool breakage.



adjustments

WARNING For your own safety turn switch OFF and remove plug from power source outlet before making any adjustments. To avoid injury from thrown parts due to spring release follow instructions carefully.

QUILL RETURN SPRING

1. Move the top nut and stop pin to the work position and lock in place with wrench to prevent slipping when tensioning spring.
2. Lower table for additional clearance.
3. Work from left side of Drill Press.
4. Place screwdriver in lower notch of spring cap and hold it in place while loosening and removing jam [outer] nut only.
5. With screwdriver remaining in notch, loosen large standard [inner] nut (approximately 1/8" until notch disengages from boss on head. DO NOT REMOVE THIS NUT).
6. Carefully turn screwdriver counter-clockwise and engage next notch in boss. DO NOT REMOVE SCREWDRIVER.
7. Tighten standard nut with wrench only enough to engage boss. Do not over-tighten as this will restrict quill movement. Remove screwdriver.
8. Move stop nuts and depth pointer to upper most position and check tension while turning feed handles.
9. If there is not enough tension on spring repeat steps 4-8 moving only ONE notch each time and checking tension after EACH repetition.
10. Proper tension is achieved when quill returns gently to full up position when released from 1/4" depth.

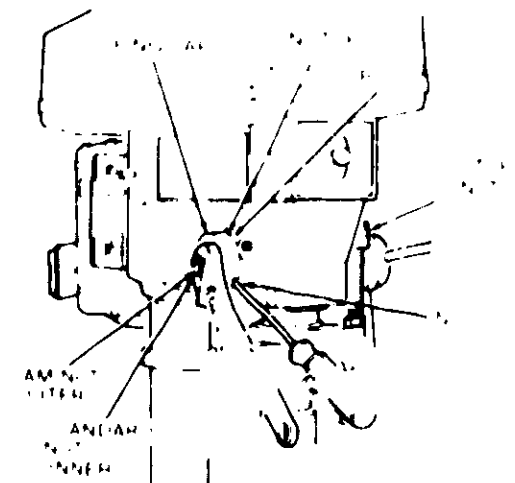

11. When there is enough tension after checking, replace jam nut and tighten to standard nut. BUT do not over-tighten against standard nut.
12. Check quill while feeding to have smooth and unrestricted movement. If movement is too tight, loosen jam nut and SLIGHTLY loosen standard nut until unrestricted. Retighten jam nut.

TILTING TABLE

To tilt the table, adjust the table to the set screw under table. Turn the set screw clockwise to raise the table and counter-clockwise to lower the table. Tighten the set screw by hand and use a wrench to tighten the set screw.

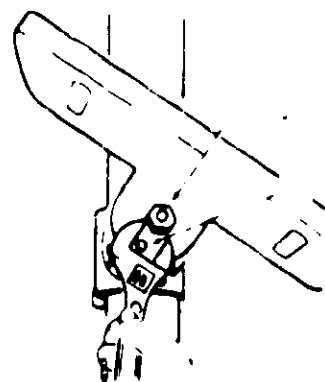

maintenance

WARNING For your own safety turn switch OFF and remove plug from power source outlet before maintaining or lubricating your drill press

Frequently clean off the dust that may accumulate on the motor.

Wipe the motor with a dry cloth. Do not use oil or other liquids to clean the motor.

WARNING To avoid shock or fire hazard if the power cord is worn or cut or damaged in any way have it replaced immediately

Lubrication

Apply the recommended lubricant to the spindle and chuck.

For more information on the proper use of the recommended lubricant, see the instructions for the recommended lubricant.

recommended accessories

WARNING Use only recommended accessories. Follow instructions that accompany accessories. Use of improper accessories may cause hazards.

Drill Bits	See Catalog	Buffing Wheels (up to 4" dia max)	See Catalog
Hand Drill and Guide	9-2457	Polishing Wheel (1 1/2" x 1")	9-2494
Drill Press Vises	See Catalog	Power Tool Know How Magazine	
Drill Press Mounting Kit	9-2957	Radial Saw	9-2917
5 Pin Stop Control Set	9-2963	Table Saw	9-2918
Sanding Drum	9-2497-9-2498		

The recommended accessories listed here are current and were available at the time this manual was printed.

trouble shooting

WARNING For your own safety, turn switch OFF and always remove plug from power source outlet before trouble shooting

• CONSULT YOUR LOCAL SEARS SERVICE CENTER FOR ANY REPAIRS. MOTOR WILL NOT RUN

TROUBLE	PROBABLE CAUSE	REMEDY
Noisy Operation	<ol style="list-style-type: none"> 1. Incorrect tension 2. Dry Spindle 3. Loose spindle pulley 4. Loose motor pulley 	<ol style="list-style-type: none"> 1. Adjust tension. See section ASSEMBLY TENSIONING BELT 2. Lubricate spindle. See Lubrication section 3. Check tightness of retaining nut on pulley and tighten if necessary 4. Tighten setscrews on pulleys
Drill Burns	<ol style="list-style-type: none"> 1. Incorrect speed 2. Chip built up on end of flute 3. Dull drill 4. Feed rate too slow 5. Not lubricated 	<ol style="list-style-type: none"> 1. Change speed. See section Getting To Know Your Drill Press (FEEDING SPEED) 2. Retract drill to clear chip 3. Resharpen drill 4. Feed fast enough - allow drill to cut. Lubricate drill. See Basic Drill Press Operation section
Drill leads off hole not round	<ol style="list-style-type: none"> 1. Hard grain in wood or lengths of cutting lips and/or angles not equal 	<ol style="list-style-type: none"> 1. Resharpen drill correctly
Wood splinters on underside	<ol style="list-style-type: none"> 1. No back up material under workpiece 	<ol style="list-style-type: none"> 1. Use back up material. See Basic Drill Press Operation section
Workpiece torn loose from hand	<ol style="list-style-type: none"> 1. Not supported or clamped properly 	<ol style="list-style-type: none"> 1. Support workpiece or clamp it. See Basic Drill Press Operation section
Drill binds in workpiece	<ol style="list-style-type: none"> 1. Workpiece pinching drill or excessive feed pressure 2. Improper belt tension 	<ol style="list-style-type: none"> 1. Support workpiece or clamp it. See Basic Drill Press Operation section 2. Adjust tension. See section ASSEMBLY TENSIONING BELT
Excessive drill runout or wobble	<ol style="list-style-type: none"> 1. Bent drill 2. Worn spindle bearings 3. Drill not properly installed in chuck 4. Chuck not properly installed 	<ol style="list-style-type: none"> 1. Use a straight drill 2. Replace bearings 3. Install drill properly. See Basic Drill Press Operation section 4. Install chuck properly refer to Unpacking and Assembly Instructions INSTALLING THE CHUCK
Quill Returns too slow or too fast	<ol style="list-style-type: none"> 1. Spring has improper tension 	<ol style="list-style-type: none"> 1. Adjust spring tension. See section Adjustments Quill Return Spring

Free Manuals Download Website

<http://myh66.com>

<http://usermanuals.us>

<http://www.somanuals.com>

<http://www.4manuals.cc>

<http://www.manual-lib.com>

<http://www.404manual.com>

<http://www.luxmanual.com>

<http://aubethermostatmanual.com>

Golf course search by state

<http://golfingnear.com>

Email search by domain

<http://emailbydomain.com>

Auto manuals search

<http://auto.somanuals.com>

TV manuals search

<http://tv.somanuals.com>