

CRAFTSMAN®

3.8 Horsepower

9 Inch

EDGER/BEVEL CUT

MODEL NO.

536.772200



Caution:
Read and follow all Safety
Rules and Operating
Instructions before first use
of this product.

SEARS, ROEBUCK AND CO., Hoffman Estates, IL 60179 U.S.A.

711942 03/27/98

SAFETY

ASSEMBLY

OPERATION

MAINTENANCE

PARTS LIST

ESPAÑOL

TABLE OF CONTENTS

Table of Contents	2	Service and Adjustments	12-13
Warranty	2	Storage	14
Safety Rules	2-3	Troubleshooting	15
Contents of Shipping Carton	4	Edger Repair Parts	16-19
Assembly	4-5	Engine Repair Parts	20-23
Operation	6-10	Spanish(Español)	24-37
Maintenance	10-12	Parts Ordering/Service	Back Cover

WARRANTY STATEMENT

LIMITED TWO-YEAR WARRANTY ON CRAFTSMAN EDGER

For two years from the date of purchase, when this Craftsman Edger is maintained, lubricated, and tuned up according to the operating and maintenance instructions in the owner's manual, Craftsman will repair, free of charge, any defect in material or workmanship.

If this Craftsman Edger is used for commercial or rental purposes, this warranty applies for only 90 days from the date of purchase.

This warranty does not cover the following:

- Expendable items which become worn during normal use, such as spark plugs, etc.
- Repairs necessary because of operator abuse or negligence, including bent crank shafts and the failure to maintain the equipment according to the instructions contained in the owner's manual.

WARRANTY SERVICE IS AVAILABLE BY RETURNING THE CRAFTSMAN EDGER TO THE NEAREST CRAFTSMAN SERVICE CENTER/DEPARTMENT IN THE UNITED STATES. THIS WARRANTY APPLIES ONLY WHILE THIS PRODUCT IS IN USE IN THE UNITED STATES.

This warranty gives you specific legal rights, and you may also have other rights which may vary from state to state.

Sears, Roebuck and Co., D817WA, Hoffman Estates, IL 60179



SAFETY RULES



**Look for this symbol to point out important safety precautions. It means---
ATTENTION!!! Become alert!!! Your safety is involved.**



CAUTION: Always disconnect spark plug wire and place wire where it cannot contact spark plug to prevent accidental starting when setting-up, transporting, adjusting or making repairs.

IMPORTANT: Safety standards require operator presence controls to minimize the risk of injury. Your Edger is equipped with such controls. Do not attempt to defeat the function of the operator presence control under any circumstances.

BEFORE USE

- Read the owner's manual carefully. Be thoroughly familiar with the controls and the proper use of the Edger. Know how to stop the edger and disengage the controls quickly.
- Do not operate the Edger without wearing adequate outer garments. Wear

footwear that will improve footing on slippery surfaces.

- Keep the area of operation clear of all persons, particularly small children and pets.
- Thoroughly inspect the area where the Edger is to be used and remove all foreign objects.

FUEL SAFETY

- Handle fuel with care; it is highly flammable.
- Use an approved container.
- Check fuel supply before each use, allowing space for expansion as the heat of the engine and/or sun can cause fuel to expand.
- Fill fuel tank outdoors with extreme care. Never fill fuel tank indoors. Replace fuel tank cap securely and wipe up spilled fuel.

- Never remove the fuel tank cap or add fuel to a running or hot engine.
- Never store fuel or Edger with fuel in the tank inside a building where fumes may reach an open flame.

OPERATING SAFETY

- Never allow children or young teenagers to operate the Edger. Keep them away while it is operating. Never allow adults to operate the Edger without proper instruction.
- Do not operate this machine if you are taking drugs or other medication which can cause drowsiness or affect your ability to operate this machine.
- Do not use this machine if you are mentally or physically unable to operate this machine safely.
- Always wear safety glasses or eye shields during operation or while performing an adjustment or repair to protect your eyes from foreign objects that may be thrown from the Edger.
- Do not put hands or feet near or under rotating parts.
- Exercise extreme caution when operating on or crossing gravel drives, walks, or roads. Stay alert for hidden hazards or traffic.
- Exercise caution to avoid slipping or falling.
- Never operate the Edger without proper guards, plates, or other safety protective devices in place.
- Never operate the Edger at high transport speeds on slippery surfaces. Look behind and use care when backing.
- Never allow bystanders near the Edger.
- Keep children and pets away while operating.
- Never operate the Edger without good visibility or light.
- Do not run the engine indoors. The exhaust fumes are dangerous, containing CARBON MONOXIDE, an ODORLESS and DEADLY GAS.
- Take all possible precautions when leaving the Edger unattended. Stop the engine.
- Do not overload the Edger capacity by attempting to edge too deep at too fast a rate.

SAFE STORAGE

- Always refer to the owner's manual instructions for important details if the Edger is to be stored for an extended period.

- Never store the Edger with fuel in the fuel tank inside a building where ignition sources are present such as water and space heaters, clothes dryers, and the like. Allow the engine to cool before storing in any enclosure.
- Keep the Edger in safe working condition. Check all fasteners at frequent intervals for proper tightness.

REPAIR/ADJUSTMENTS SAFETY

- After striking a foreign object, stop the engine (motor). Remove the wire from the spark plug, and keep the wire away from the plug to prevent accidental starting. Thoroughly inspect the Edger for any damage, and repair the damage before restarting and operating it.
- If Edger should start to vibrate abnormally, stop engine (motor) and check immediately for the cause. Vibration is generally a warning of trouble.
- Stop the blade whenever you leave the operating position. Also, disconnect the spark plug wire before unclogging the blade and when making any repairs, adjustments or inspections.
- When cleaning, repairing or inspecting, shut off the engine and make certain all moving parts have stopped.
- Never attempt to make any adjustments while the engine is running except when specifically recommended by the manufacturer.

⚠ WARNING: The engine exhaust from this product contains chemicals known to the State of California to cause cancer, birth defects or other reproductive harm.

⚠ WARNING: This unit is equipped with an internal combustion engine and should not be used on or near any unimproved forest-covered, brush-covered or grass-covered land unless the engine's exhaust system is equipped with a spark arrester meeting applicable local or state laws (if any). If a spark arrester is used, it should be maintained in effective working order by the operator.

In the state of California the spark arrester is required by law (Section 4442 of the California Public Resources Code). Other states may have similar laws. Federal laws apply on federal lands. A spark arrester/muffler is available through your nearest Craftsman Authorized Service Center (See ENGINE REPAIR PARTS section in this manual).

Contents of Parts Bag (shown full size)

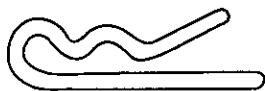

(2) - Hair Pins

1 - Owner's Manual (not shown)

Parts packed separately in carton (not shown full size)



(1) -Control Rod

1 - Container SAE30 Oil(20 ounces)

1 - Parts Bag (not shown)

ASSEMBLY

CAUTION: Always wear safety glasses or eye shields while assembling Edger.

The figure to the right shows the Edger completely assembled.

References to the right or left hand side of the Edger are from the viewpoint of the operator's position behind the unit.

TO REMOVE EDGER FROM CARTON

- Remove the control rod, bottle of oil and parts bag from carton.
- Cut down all four corners of the carton.
- Remove packing material on front and rear of unit. Leave packing material on bottom of unit until control rod is assembled. This will help keep the front wheel in a stable position to allow for easier assembly of control rod.

TO ASSEMBLE THE EDGER

- Loosen T-knobs before pivoting the upper handle upward being careful not to pinch or pull the engine control wire, until the handles align, then tighten T-knobs. T-knobs should be to the outside of the handles as shown in second figure.

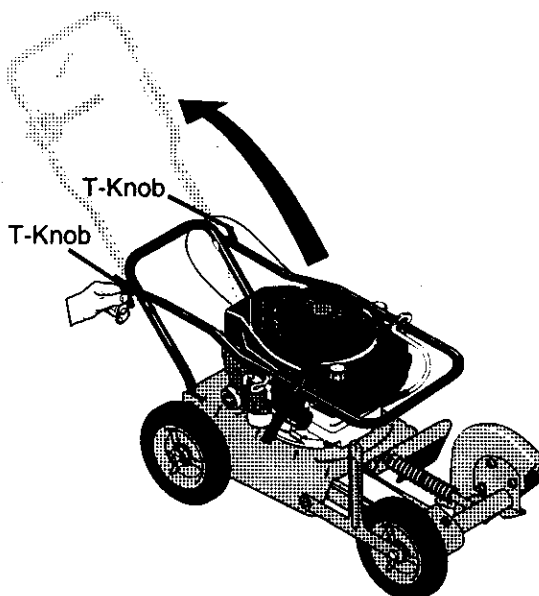
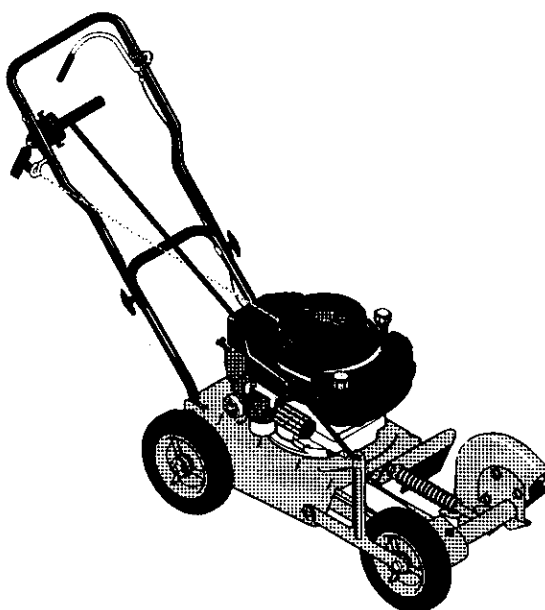

- Insert one end of the control rod from right to left through the hole in the front wheel bracket. Attach with hairpin found in parts bag. See figure below.

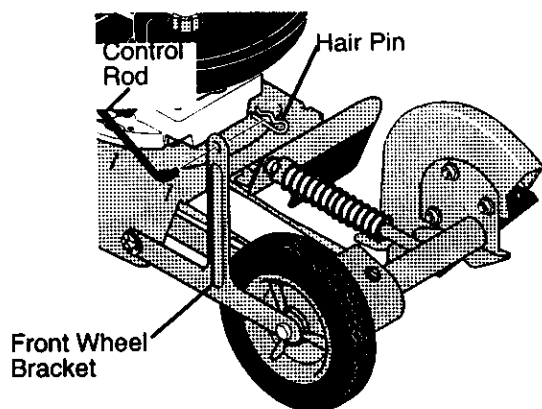

- To attach the recoil starter rope to the rope guide, twist the rope through the rope guide mounted on the right side of the handle.

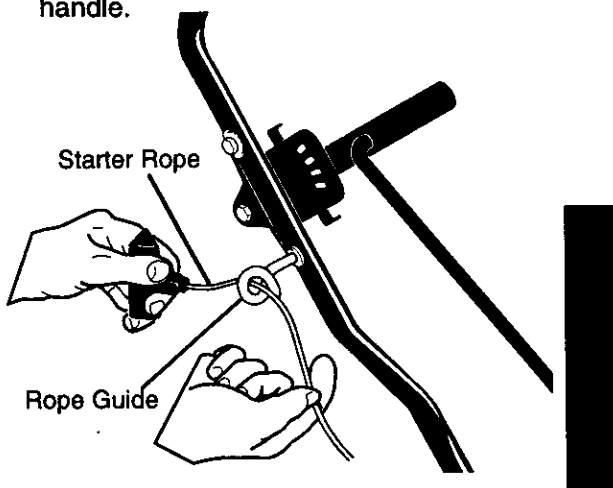

- Push down on handle to tilt unit back.
- Insert the other end of the control rod from right to left through the hole in the depth control lever. Attach with hairpin found in parts bag. See figure below.
- Depth control lever should be in forward most selection slot for transport and starting. See figure below.
- Remove bottom packing material.

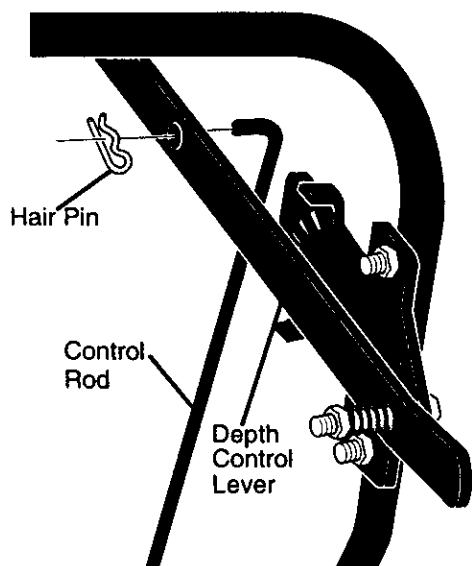
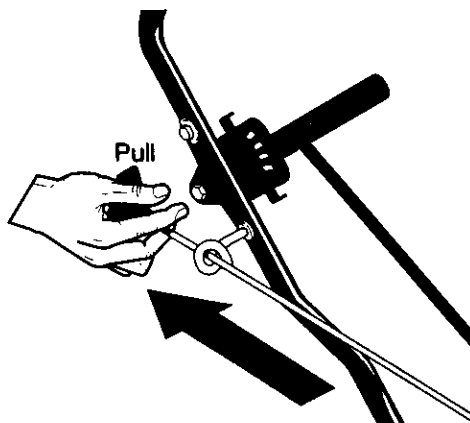

✓ CHECKLIST

Before you operate your new Edger, to ensure that you receive the best performance and satisfaction from this quality product, please review the following checklist:

- ✓ All assembly instructions have been completed.
- ✓ No remaining loose parts in carton.
- ✓ All fasteners have been properly installed and tightened.

While learning how to use your Edger, pay extra attention to the following important items:

- ✓✓ Engine oil is at proper level.
- ✓✓ Fuel tank is filled with fresh, clean, regular Unleaded gasoline.
- ✓✓ Become familiar with all controls, their location and function. Operate controls before starting engine.

OPERATION

KNOW YOUR EDGER

READ THIS OWNER'S MANUAL AND SAFETY RULES BEFORE OPERATING YOUR EDGER. Compare the illustrations with your EDGER to familiarize yourself with the location of various controls and adjustments. Save this manual for future reference.



Fast



Slow



Stop



Primer Button

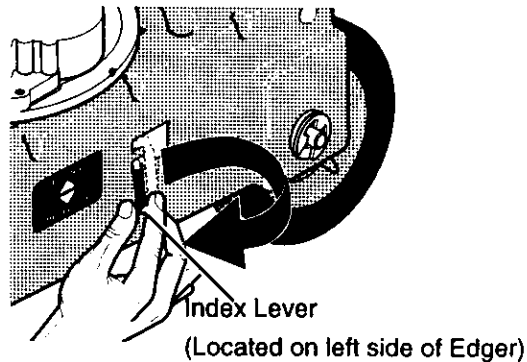
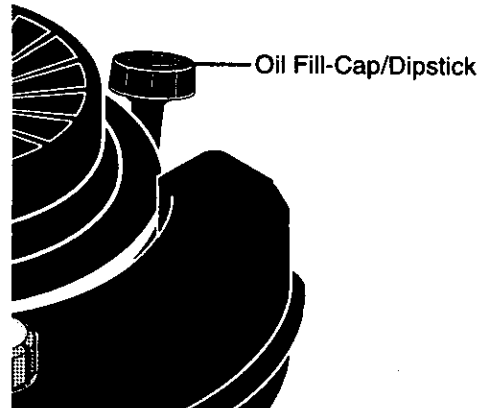
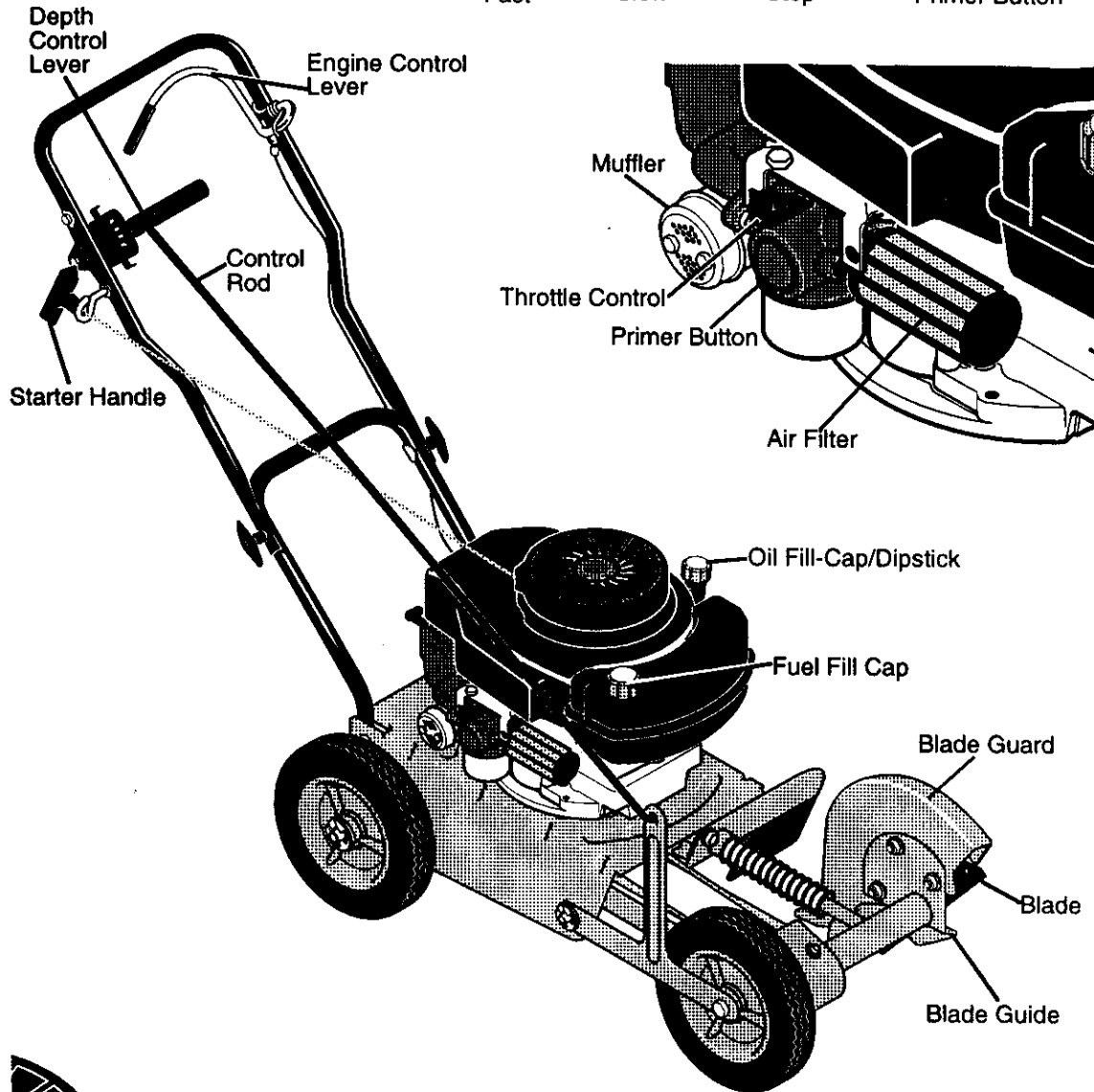

Throttle Control – Used to control the engine speed.

Primer Button – Injects fuel directly into the carburetor manifold for faster starts.

Starter Handle – The engine on this edger is equipped with an easy pull recoil starter.

Depth Control Lever – Controls the depth of the blade.

Blade Guard – Used to prevent stones or other material from being thrown at the operator.

Engine Control Lever – Must be held back to allow engine to start and run.

Index Lever – Permits adjustment from the edging (vertical) position to beveling (45°) position. To change position, pull the index lever and rotate the quill assembly to the desired angle or position.

⚠ WARNING: Blade is rotating when engine is running or being started. Keep hands and feet away from blade to prevent injury.

HOW TO USE YOUR EDGER

⚠ WARNING: The operation of this Edger can result in foreign objects being thrown into the eyes, which can cause severe eye damage. Always wear safety glasses or eye shields while operating the Edger.

We recommend standard safety glasses or Wide Vision Safety Mask for over your glasses.

TO STOP EDGER

- Make sure the depth control lever is all the way forward and release engine control lever. There is a **STOP** position on the throttle control lever in case of a failure with the engine control lever. Wait for all moving parts to stop before leaving the operator position.

⚠ CAUTION: Never leave the Edger unattended while the engine is running. Always raise the cutting blade and stop the engine.

TO USE THE ENGINE CONTROL LEVER

- Pull the engine control lever back with your left hand and hold it in contact with the upper handle cross tube to allow engine to start and run. See next figure.
- Release the engine control lever to stop the engine.

NOTE: If engine continues to run after lever is released, use the stop **STOP** position on the throttle control to stop the engine. See your Craftsman Service Center to correct the engine control lever problem.

⚠ CAUTION: Always stop the engine and make sure all parts have stopped whenever leaving the operator's position or when cleaning, replacing or inspecting the Edger.

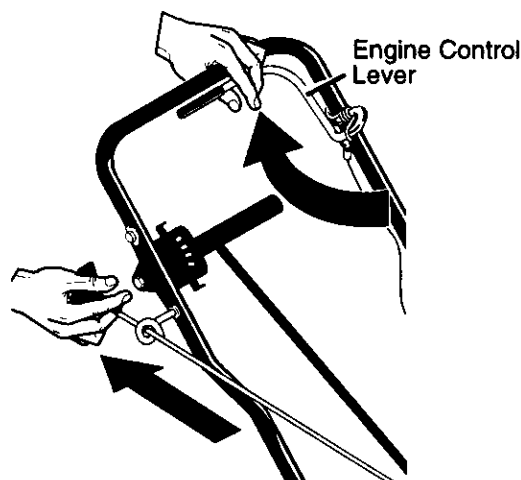

TO USE THROTTLE CONTROL

- Run at full engine speed during normal use.
- Push throttle control lever forward to increase speed; back to decrease speed.
- Pulling the throttle control lever all the way back will stop **STOP** the engine.

TO USE PRIMER BUTTON

- Push primer button five times. See page 6 figure for location. Wait about two seconds between each push.

NOTE: Do not use primer button to restart a warm engine after a short shut-down.

TO USE THE DEPTH CONTROL LEVER

- Position your Edger in desired edging location before operating.
- Start the engine and move the depth control lever back to lower the cutting blade.
- Select the edging depth you need. There are 3 selections up to approximately 2 inches deep.

IMPORTANT: If very deep edging is required, we recommend that a shallow cut be made first, then cut at greater depths until the desired depth is obtained.

⚠ WARNING: Keep away from the rotating blade. The blade can cause injury.

TO USE THE INDEX LEVER (BEVELING OPERATION)

- Stop engine and disconnect the spark plug wire from the spark plug.

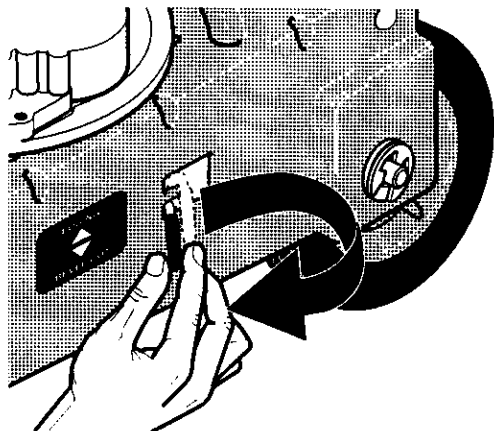

INDEX LEVER IN THE NOTCH MARKED BEVEL CUT

- Pull the index lever out of the edging notch as shown above and position it in the notch marked **bevel cut**.
- Reconnect the spark plug wire and start the engine. Move the depth control lever to the desired beveling depth.

⚠ CAUTION: Never leave the Edger unattended while the engine is running. Prior to adjusting the indexing blade position, always raise the cutting blade and stop the engine.

WARNING: Keep away from the rotating blade. The blade can cause injury.

TO USE THE BEVEL CUT FEATURE

Bevel edging reduces the need to edge as often creating a type of trench along your sidewalk, driveway and etc. Move the index lever to the bevel cut position and secure index lever in the slot. Prior to starting the engine, line the Edger up as if you were going to bevel cut and move the depth control lever down to test the blade location. Return the depth control lever to the forward slot of the adjustment bracket to raise the blade. Start the engine and move the depth control lever to the desired depth of cut.

BEFORE STARTING ENGINE

PRE-USE CHECK OF CONTROLS

All controls should be checked for proper function before servicing or starting the engine.

- Move the depth control lever into all three positions in the selector plate. Make sure the depth control lever snaps into all three holes as shown in figure on page 6.
- Return the depth control lever to the forward hole in the selector plate.

FILL/ADD OIL:

This Edger was shipped with a 20 ounce container of SAE30 motor oil. This oil must be added to the engine before operating. Remove the oil fill cap/dipstick and fill the crankcase to **FULL** line on dipstick. Your engine may not require the entire 20 ounces of oil. **DO NOT OVERFILL.**

NOTE: Engine may already contain some residual oil.

Tighten the fill cap/dipstick securely each time you check the oil level.

OIL RECOMMENDATIONS

Only use high quality detergent oil rated with API service classification SG. Select the oil's SAE viscosity grade according to your expected operating temperature:

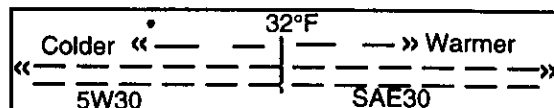

NOTE: Although multi-viscosity oils (5W30, 10W30, etc.) improve starting in cold weather, these multi-viscosity oils will result in increased oil consumption when used above 32°F. Check your engine oil level more frequently to avoid possible engine damage from running low on oil.

TO ADD ENGINE OIL

- Place the Edger on a level surface.
- Remove the oil fill cap/dipstick as shown in next figure.
- Fill the engine crankcase, pouring slowly. **DO NOT OVERFILL.** For approximate capacity see **PRODUCT SPECIFICATIONS** on page 11 of this manual.
- Reinstall the oil fill cap/dipstick and tighten securely. Wipe away excess oil.
- Check oil before each use. Add if needed.

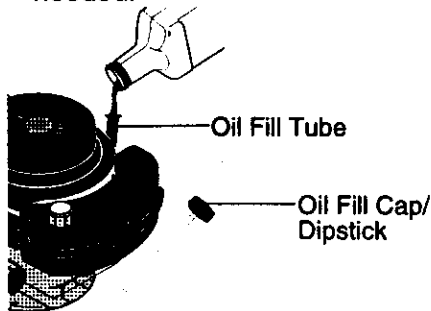

⚠ CAUTION: Never fill the gas tank while the engine is running or hot. Immediately wipe off any spilled gasoline before attempting to start the engine.

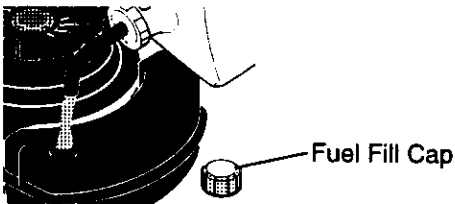

FILL GAS:

NOTE: ENGINES WHICH ARE CERTIFIED TO COMPLY WITH CALIFORNIA AND US EPA EMISSION REGULATIONS FOR ULGE ENGINES: Are certified to operate on regular unleaded gasoline. Include the following emission control system(s): EM, TWC (if so equipped). Include any user adjustable features - therefore no other adjustments are needed. Fill the fuel tank with clean, fresh, unleaded premium, or reformulated automotive gasoline only. **DO NOT** use leaded gasoline. Be sure that the container you pour the gasoline from is clean and free from dust or other foreign particles. Never use gasoline that may be stale from long periods of storage in the container. Reinstall fuel cap.



WARNING: Experience indicates that alcohol blended fuels (called gasohol or using methanol) can attract moisture which leads to separation and formation of acids

during storage. Acidic gas can damage the fuel system of an engine while in storage. To avoid engine problems, the fuel system should be emptied before storage of 30 days or longer. Drain fuel tank, start engine and let it run until fuel lines and carburetor are empty. Use fresh fuel next season. See Storage Instructions for additional information. Never use engine or carburetor cleaner products in the fuel tank or permanent damage may occur.

⚠ WARNING: Gasoline is flammable and caution must be used when handling or storing it. Do not fill fuel tank while Edger is running, hot, or when Edger is in an enclosed area. Keep away from open flame, electrical spark, and do not smoke while filling the fuel tank. Never fill fuel tank completely; but fill the tank to within 1/4-1/2 inch from the top to provide space for expansion of fuel. Always fill fuel tank outdoors and use a funnel or spout to prevent spilling. Make sure to wipe up any spilled fuel before starting the engine. Store gasoline in a clean, approved container, and keep the cap in place on the container. Keep gasoline in a cool, well ventilated place; never in the house. Never buy more than a 30 day supply of gasoline to ensure volatility. Gasoline is intended to be used as a fuel for internal combustion engines; therefore, do not use gasoline for any other purpose. Since many children like the smell of gasoline, keep it out of their reach because the fumes are dangerous to inhale, as well as being explosive.

TO START THE ENGINE

Before starting the engine, be sure you have read and understood all the instructions on the preceding pages. The Edger is equipped with a recoil starter. The operation of the engine is controlled by the throttle control lever. See page 6.

- Push the depth control lever forward and latch in the forward slot of the adjustment bracket to raise the blade.
- Move the throttle control lever, see figure on page 6, to the **FAST**  position.
- Push primer button  five times, see figure on page 6. Wait about two seconds between each push.

NOTE: Do not use primer to restart a warm engine after a short shutdown.

- Pull the engine control lever back to contact the upper handle tube and hold the Edger handle and control lever firmly



with your left hand.

- To start engine, grasp the engine starter handle firmly with your right hand.
- Pull back sharply on the recoil starter handle. **DO NOT** allow the starter rope to snap back, let it rewind slowly while holding the starter handle.

NOTE: If engine fails to start after three pulls, push primer button two times and pull starter rope again.

- When the engine starts, run at full engine speed during normal use.

NOTE: The cutting blade speed is controlled by the engine speed. To reduce the cutting blade speed, push back on the throttle control lever. To increase the blade speed, push the throttle control lever forward.

- To stop  the engine, make sure the depth control lever is all the way forward and release the engine control lever to the stop position or push the throttle control lever to stop . See figure on page 6.

⚠ WARNING: Never run the engine indoors or in a poorly ventilated area. Engine exhaust contains carbon monoxide, an odorless and deadly gas. Keep hands, feet, hair and loose clothing away from any moving parts on the engine or Edger. Avoid the muffler and surrounding areas. Temperatures may exceed 150° F.

EDGING TIPS

- Edging is best performed when conditions are dry. If the soil is too wet, dirt becomes packed in and around the blade causing premature belt wear and decreased performance.
- If dirt does become packed around the blade, stop the engine, remove the spark plug wire, and remove the packed debris before continuing to edge.
- If very deep edging is required, we recommend that a shallow cut be made first, then cuts at greater depth until the desired depth is obtained.
- Uniform edging can be performed when the blade guide (see figure on page 6) rides on and against the surface which you are edging.
- Edging can be customized by varying the number of passes and by the distance your blade is from the surface you are edging.

MAINTENANCE

CUSTOMER RESPONSIBILITIES

SERVICE RECORDS Fill in dates as you complete regular service	SCHEDULE								SERVICE DATES			
	After First 2 Hours	Before Each Use	Frequently	Every 5 Hours	Every 10 Hours	Every 25 Hours	Begin Each Season	Before Storage				
Lubricate all Pivot Points					✓			✓				
Check Engine Oil Level		✓										
Change Engine Oil						✓	✓					
Replace Air Cleaner Filter							✓					
Check Spark Plug						✓	✓					
Check Drive Belt			✓									
Tighten All Screws and Nuts	✓		✓									
Check Blade Wear/Damage			✓									
Lubricate Quill Rod/Tube					✓		✓	✓				

PRODUCT SPECIFICATIONS

HORSE POWER:	3.8
DISPLACEMENT:	10 cu. in. (163cc)
GASOLINE CAPACITY:	1.25 qt. (unleaded regular)
LUBRICATION:	20 oz. SAE-30W
SPARK PLUG:	Champion RJ19LM (Gap .030) or Equivalent

GENERAL RECOMMENDATIONS

The warranty on this Edger does not cover items that have been subjected to operator abuse or negligence. To receive full value from the warranty, the operator must maintain the Edger as instructed in this manual. The above chart is provided to assist the operator in properly maintaining the Edger.

LUBRICATION

- After each 25 hours of use of your Edger, apply light machine oil to all moving parts.
- We recommend that the oil in the engine crankcase be changed after each 25 hours of use thereafter.

NOTE: If the Edger is being used in sandy or dusty areas, change the oil more frequently to prevent premature engine wear.

TO CHANGE ENGINE OIL

- Disconnect the spark plug wire from the spark plug.
- Remove the oil drain plug as shown in first figure on this page and drain the oil into a flat pan.
- After draining all the oil, reinstall the oil drain plug securely.

NOTE: The oil will drain more freely when the engine is warm.

- Remove the oil fill cap/dipstick. See first figure on page 9.
- Fill the engine crankcase, pouring slowly. **DO NOT OVERFILL.** For approximate capacity see **PRODUCT SPECIFICATIONS** on this page.

NOTE: The quill assembly bearings are factory sealed and will require no lubrication.

- Reconnect the spark plug wire on the spark plug.

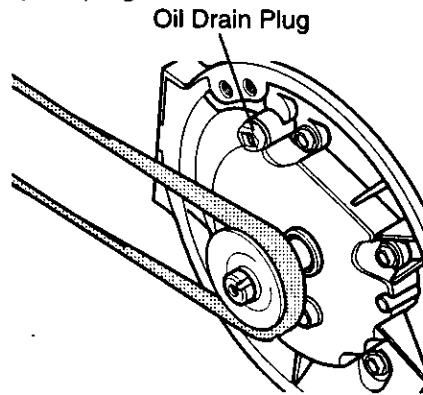

AIR CLEANER

Replace the filter once a year; more often under dusty or dirty conditions. **DO NOT** attempt to clean or oil the air filter.

To install a new air filter, do the following:

- Disconnect the spark plug wire from the spark plug.
- Turn the cover as shown below to the left (counterclockwise) and remove the cover and the air filter from the flange.
- Discard the air filter.
- Clean the cover and the flange thoroughly.
- Insert the new air filter into the cover.
- Push the cover firmly against the flange and turn it to the right (clockwise) as far as it will go as shown in figure below. Be sure the retainers are locked around the flange.
- Reconnect the spark plug wire.

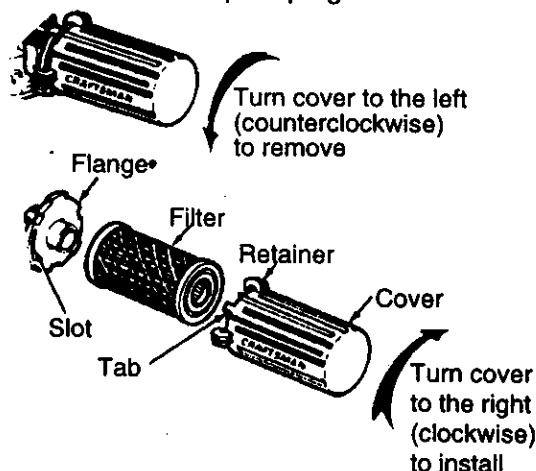

CAUTION: Never run the engine without the air cleaner element installed. A defective air cleaner can result in loss of engine power and can cause excessive wear or damage to the engine components if dirt or dust is permitted to enter the engine through the carburetor. A damaged air cleaner, or one that is clogged with dust or dirt should be replaced immediately.

SPARK PLUG

Clean the spark plug and reset the gap periodically. Clean the area around the spark plug base before removal, to prevent dirt from entering the engine. Replace the spark plug if the electrodes are pitted or

burned or if the porcelain is cracked. Clean the spark plug by carefully scraping the electrodes (do not sand blast or use a wire brush). Be sure the spark plug is clean and free of foreign material. Check the electrodes gap with a wire feeler gauge and reset to .030 inches if necessary. If a new spark plug is needed, refer to the **PRODUCT SPECIFICATIONS** on page 11 for the proper replacement spark plug.

Before reinstalling the spark plug, coat the threads lightly with graphite or light oil to insure easy removal. Tighten the spark plug firmly into the engine. If a torque wrench is available, torque the spark plug to 15 foot-pounds.

SERVICE AND ADJUSTMENTS

CAUTION: Always stop the engine and disconnect the spark plug wire before making any repairs to the Edger.

V-BELT REPLACEMENT

Your Edger is equipped with a V-belt made of a special compound. If the belt becomes worn or breaks, replace it with an original equipment belt as shown in the Repair Parts section of this manual. Never use a substitute.

- Disconnect the spark plug wire.
- Drain gasoline and oil from Edger.
- Tip Edger backwards on handle and block top of handle against wall or bench.
- Remove three screws from the belt guard as shown in first figure.
- Push blade bearing housing back towards engine to compress spring and release tension on belt.
- Remove old belt (carefully note direction of twist around engine pulley). See second figure.
- While spring is compressed, install new belt on quill and engine pulleys being sure to twist belt in proper direction as shown in second figure.

NOTE: If belt is not installed properly the blade will not turn in the proper direction and could damage the blade or belt. Refer to second figure for proper direction of belt travel.

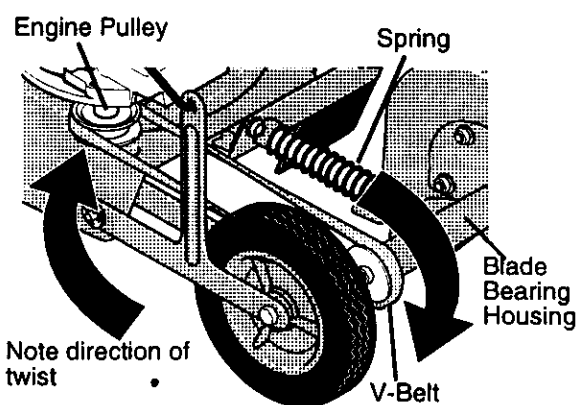
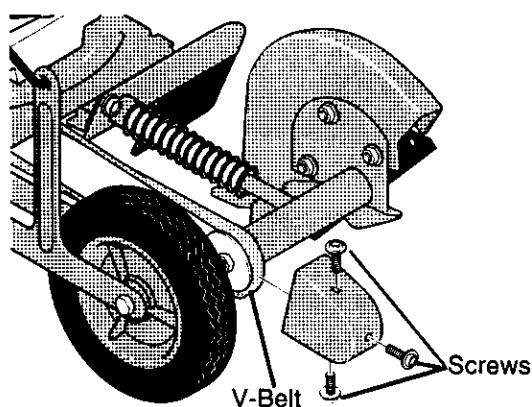

BLADE REPLACEMENT

The cutting blade is subject to wear and damage such as nicks and dents. This will not generally affect its function.

This blade is specially designed to not require sharpening. Do not attempt to sharpen this blade. If worn or damaged the blade should be replaced.

CAUTION: When removing or tightening the blade nut, always use the method shown in figure below. The holding wrench must always be positioned on the nut behind the cutting blade.

⚠ CAUTION: Do not attempt to sharpen this blade. You could cause damage to the blade which could result in breakage and possible user or bystander injury.

To replace the blade, do the following:

- Disconnect spark plug wire.
- Remove the 1/2-20 locknut shown in figure below securing the blade to the drive shaft.
- Remove the blade.

IMPORTANT: Note the position of the washer and the blade cutting edge to ensure proper re-assembly. The blade is marked **THIS SIDE OUT**.

- Position the replacement blade against the washer on the drive shaft and secure with flange nut. Be sure to tighten nut securely to 40-45 foot pounds.
- Reconnect the spark plug wire.

WARNING: Always wear gloves when working on blade, it is sharp.

CARBURETOR ADJUSTMENT

The carburetor has been pre-set at the factory and readjustment should not be necessary. However, if the carburetor does need to be adjusted, contact your nearest Craftsman Service Center.

IMPORTANT: Never tamper with the engine governor, which is factory set for proper engine speed. Overspeeding the engine above the factory high speed setting can be dangerous. If you think the engine-governed high speed needs adjusting, contact your nearest Craftsman Service Center, which has the proper equipment and experience to make any necessary adjustments.

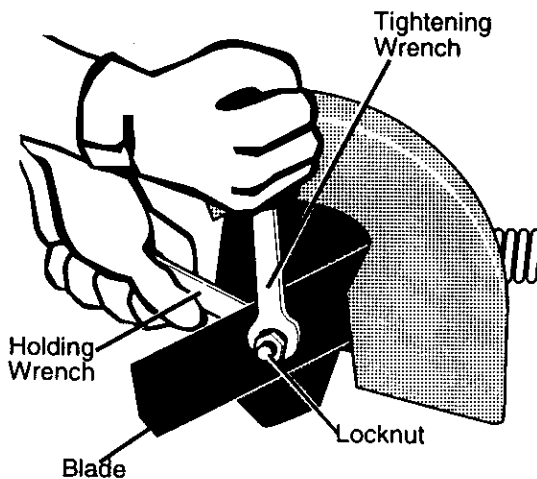

STORAGE

⚠ WARNING: Never store your Edger indoors or in an enclosed, poorly ventilated area. If gasoline remains in the tank, fumes may reach an open flame, spark or pilot light from a furnace, water heater, clothes dryer, cigarette, etc.

EDGER

- Clean the Edger thoroughly; remove all debris and wipe the unit dry.
- Inspect the Edger for worn or damaged parts and tighten all loose hardware.
- Oil all points described in the Lubrication paragraph in the **MAINTENANCE** section of this manual.
- Store the Edger in a protected area and cover for additional protection.

IMPORTANT: A yearly checkup or tune-up by a Craftsman Service Center is a good way of ensuring that your Edger will provide maximum performance for the next season.

ENGINE

IMPORTANT: It is important to prevent gum deposits from forming in essential fuel system parts such as the carburetor, fuel filter, fuel hose, or tank during storage. Also, experience indicates that using alcohol-blended fuels (called gasohol, ethanol or methanol) can attract moisture which leads to separation and formation of acids during storage. Acidic gas can damage the fuel system of an engine while in storage.

To prevent engine damage (if Edger is not used for more than 30 days) follow the steps below.

- To remove gasoline, run the engine until the tank is empty and the engine stops.
- If you do not want to remove gasoline, a fuel stabilizer (such as Craftsman fuel stabilizer No. 33500) may be added to any gasoline left in the tank to minimize gum deposits and acids. If the tank is almost empty, mix stabilizer with fresh gasoline in a separate container and add some to the tank. Always follow instructions on stabilizer container. Then run engine at least 10 minutes after stabilizer is added to allow mixture to reach

carburetor. Store Edger in a safe place. See warning on this page.

- Store the Edger in the wheels-down, operating position. If the Edger is stored in any other position, oil from the crankcase could enter the cylinder, causing a service problem.

You can keep your engine in good operating condition during storage by:

- Changing oil.
- Lubricating the piston/cylinder area. This can be done by first removing the spark plug and squirting clean engine oil into the spark plug hole. Then cover the spark plug hole with a rag to absorb oil spray. Next, rotate the engine by pulling the starter two or three times. Finally, reinstall spark plug and attach spark plug wire.

TROUBLE SHOOTING

TROUBLE	CAUSE	CORRECTION
Difficult starting or Engine runs erratically	Stale fuel	Drain fuel tank. Fill with fresh fuel
	Defective spark plug	Clean and re-gap spark plug
	Clogged fuel line	Replace fuel filter
	Blocked fuel line or empty fuel tank	Clean fuel line; check gas tank
	Carburetor out of adjustment	Have carburetor adjusted
	Fouled spark plug	Clean and adjust gap, replace
	Clogged air cleaner	Replace air filter
Cutting blade fails to turn	Jammed due to foreign object	Clear obstruction
	Loose blade	Tighten blade retaining nut
	Defective belt	Replace V-belt
	Defective quill bearings	Replace the quill assembly
Blade fails to cut properly	Damaged or worn blade	Replace blade
Excessive vibration	Loose parts	Stop engine immediately; tighten all bolts. If vibration continues, take the unit into the nearest Craftsman Service Center
Engine will not shut off when engine control lever is released	Handle hardware is not cutting into tube	Tighten T-knobs until the external lockwasher cuts into the tubing

**CRAFTSMAN 9" - 3.8H.P. EDGER/BEVEL CUT 536.77200
ENGINE/FRAME ASSEMBLY**

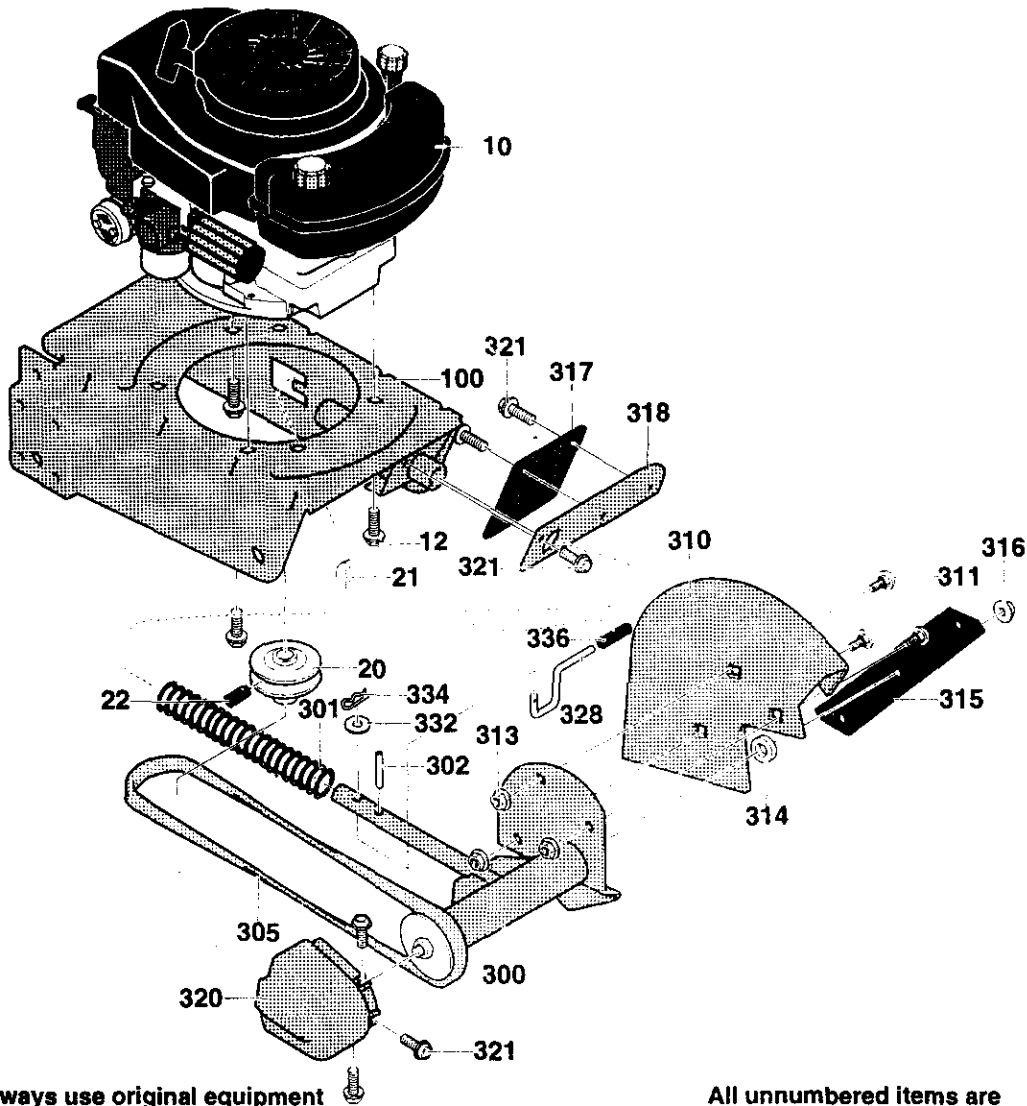

Note: Always use original equipment parts. Use of service/replacement parts other than original parts may void your warranty.

All unnumbered items are interchangeable with opposite side

343714B

REF. NO.	PART NO.	PART NAME
10	ENGINE	3.8HP 143.983804 (See Engine pages)
12	47792	Screw, 3/8-16 x 1.00
20	52052	Pulley, V3L 2.50X.75
21	338490	Key, Hi Pro#505
22	102580	Screw, 5/16-18 x .25
100	740124-833	Frame Assembly
300	740055	Quill Assembly
301	51603	Spring
302	412281	Pin, Spring
305	32668	Belt, V 4L 32.60Lg
310	331076-833	Guard, Blade
311	57072	Carriage Bolt, 5/16-18x.63
313	710205	Nut, 5/16-18 Wdflik
314	22265	Flatwasher.515x1.38x.119
315	20562-853	Blade, Edger

REF. NO.	PART NO.	PART NAME
316	46023	Nut, 1/2-20 WDFL
317	338582	Deflector, Rubber
318	337792-833	Plate, Rubber Flap
320	336631	Belt Guard
321	710271	Screw, 10-16x.50 TAP
328	740004	Lever, Blade Index
330	740002	Spring, Blade Index Lever
332	4230	Washer Flat .328x.68x.104
334	36368	Pin, Hair .072Diax1.13Lg
336	740005	Cover, Index Lever
	711942	Owner's Manual Eng/Sp

**CRAFTSMAN 9" -3.8H.P. EDGER/BEVEL CUT 536.772200
HANDLE ASSEMBLY**

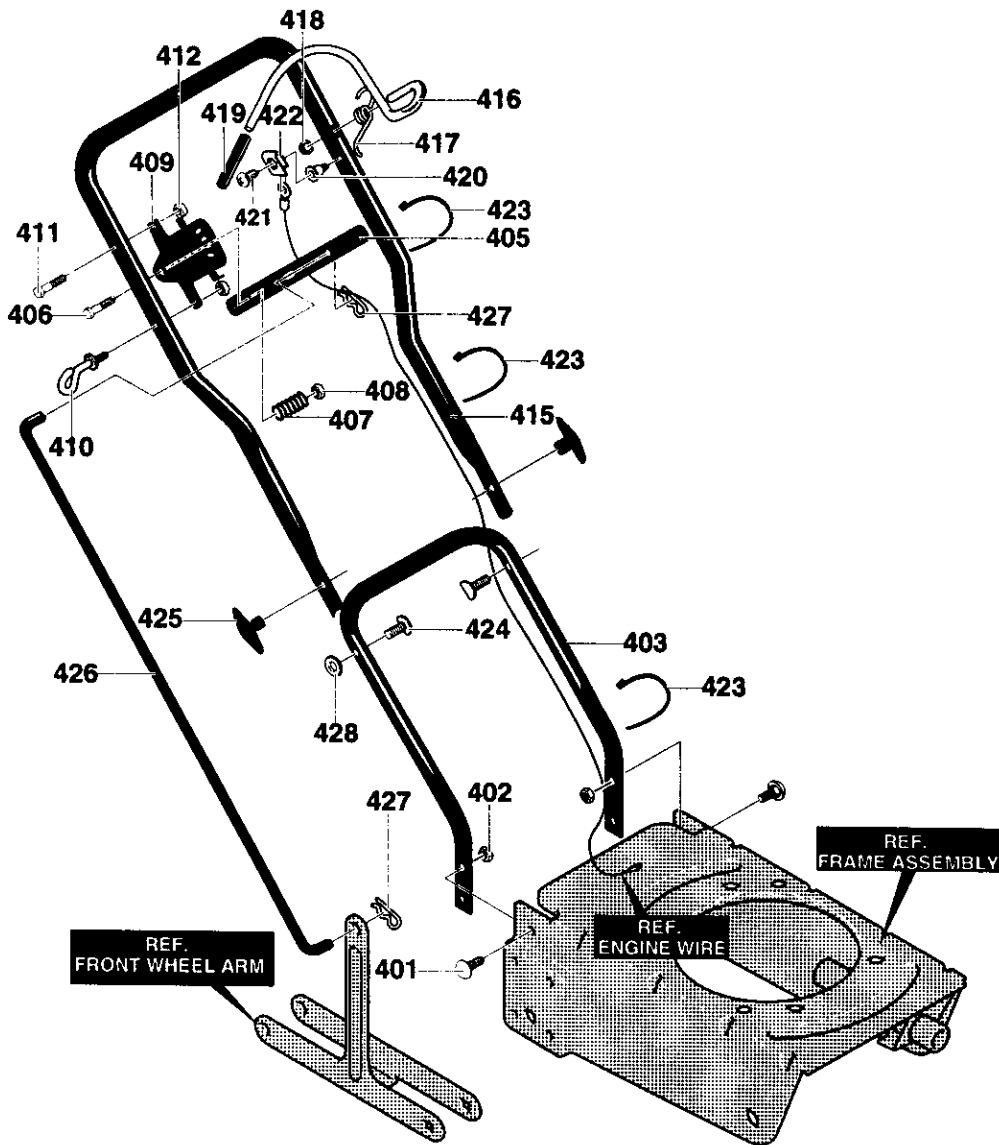

343712C

REF. NO.	PART NO.	PART NAME	REF. NO.	PART NO.	PART NAME
401	711558	Carriage Bolt 5/16-18x.75	418	314276	Nut, Push on 1/4
402	45174	Nut, 5/16-18 Hexwdflik	419	339489	Cap, Operator Control
403	740128-853	Handle, Lower 7/8"	420	339229	Insulator, Operator Control
405	740130-853	Handle, Depth Adjust	421	57796	Screw, #6x.50 Plastite
406	180081	Screw, 5/16-18x1.25	422	340162	Clip, Grounding
407	25644	Spring	423	57444	Cable Tie
408	1498	Nut, 5/16-18 Reghexctrk	424	315288	Bolt, 5/16-18x1.75 CUH
409	740143-853	Bracket, Quadrant	425	671294	Knob, Wing 5/16-18 Nut
410	672510	Rope Guide	426	740144-853	Control Rod
411	180024	Screw, 1/4-20x1.25	427	36368	Hair Pin
412	782585	Nut, 1/4-20 Reghexctrk	428	138485	Washer, Exlk .320x.61x.03
415	740142-853	Handle, Upper			
416	337744	Bail, Operator Control			
417	337775	Spring, Torsion			

CRAFTSMAN 9" - 3.8H.P. EDGER/BEVEL CUT 536.77200
WHEELS ASSEMBLY

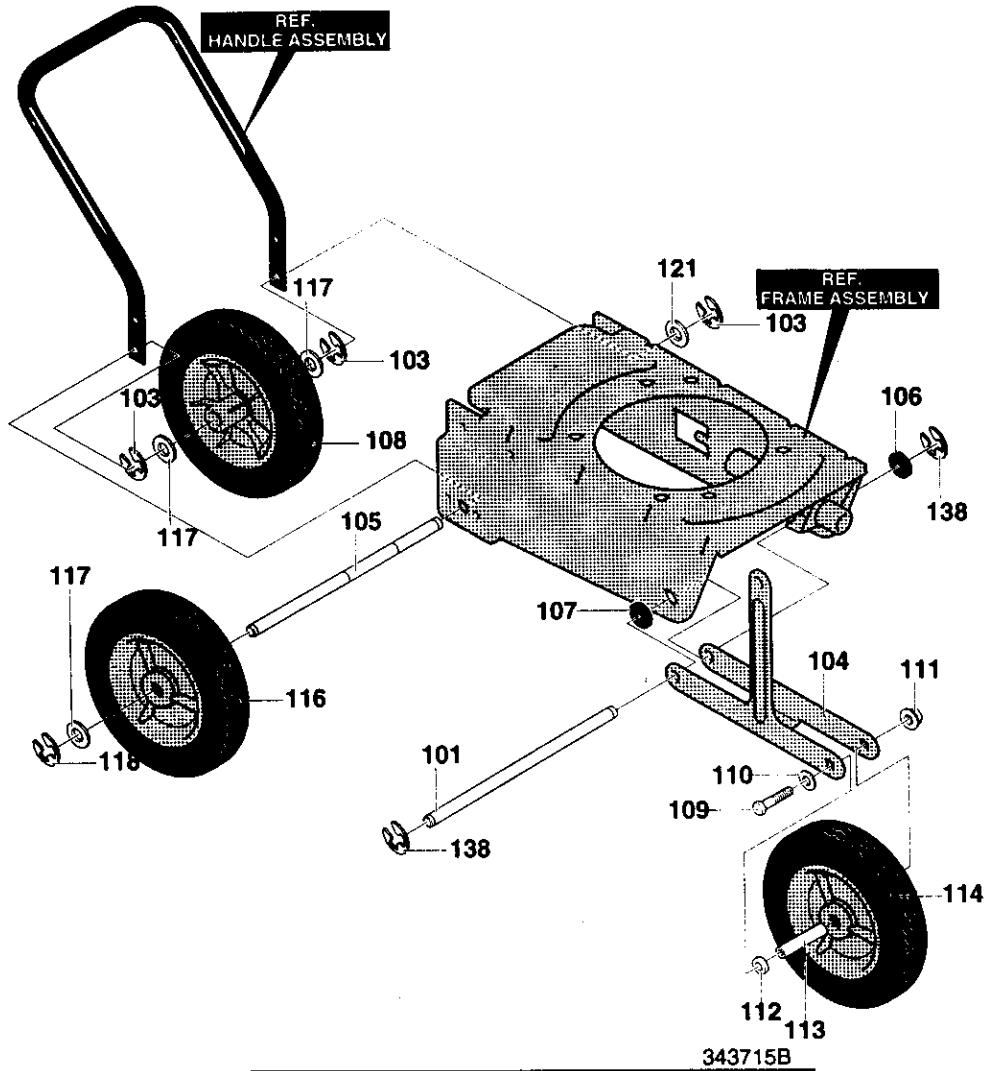

343715B

REF. NO.	PART NO.	PART NAME
101	740091	Rod, Axle Front
103	20864	Ring, Ret E
104	740126-833	Bracket, Front Curb Hop
105	740090	Rod, Rear Axle
106	417098	Flatwasher .531x1.06x.063
107	710258	Washer, Spring .50x1.0x.021
108	339079	Tire & Rim 7x1.50
109	180091	Screw, 5/16-18x2.50 HHC
110	120393	Flatwasher .344x.69x.065
111	710205	Nut, 5/16-18 Wdfilk
112	711008	Washer, Nylon .51x1.25x.312
113	740046	Spacer, Slev
114	339079	Tire & Rim 7x1.50
116	339079	Tire & Rim 7x1.50
117	2968	Flatwasher .504x.75x.059
118	20864	Ring, Ret. E
121	417098	Flatwasher .531x1.06x.063
138	20864	Ring, Ret E. .39x.04TRU

CRAFTSMAN 9" - 3.8H.P. EDGER/BEVEL CUT 536.772200

DECALS

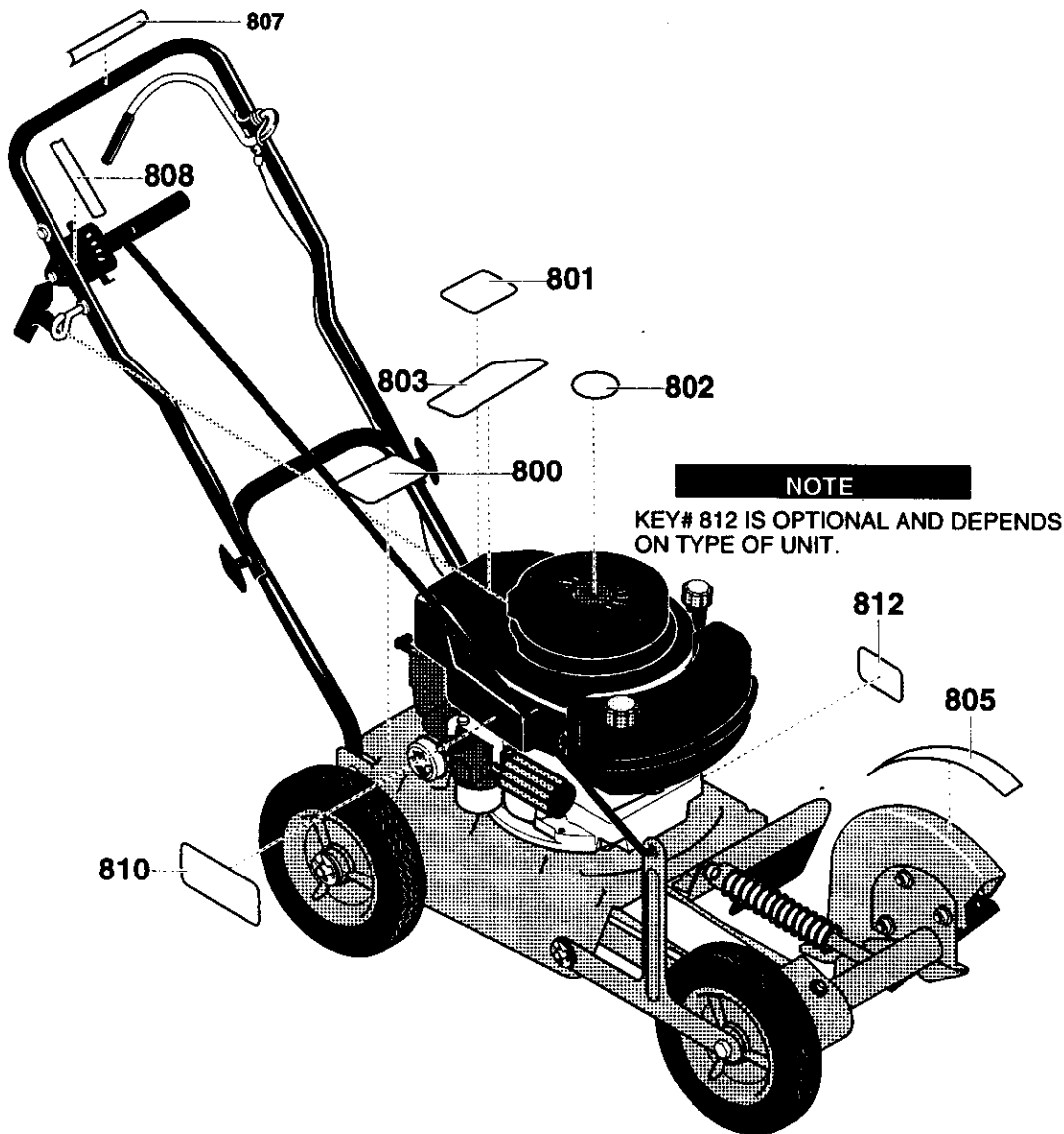

NOTE

KEY# 812 IS OPTIONAL AND DEPENDS ON TYPE OF UNIT.

REF. NO.	PART NO.	PART NAME
800		Reference Only
801	69711	Decal, Information Danger
802	712115	Decal, Recoil Cover
803	740085	Decal, Engine 3.8HP
805	333874	Decal, Blade Cover
807	402862	Decal, Eng. Cont. Lever
808	402859	Decal, Blade Height
810	710034	Decal, Primer Cold Start
812	710421	Decal, Blade Position

343713A

CRAFTSMAN 4-CYCLE ENGINE MODEL NUMBER: 143.983804

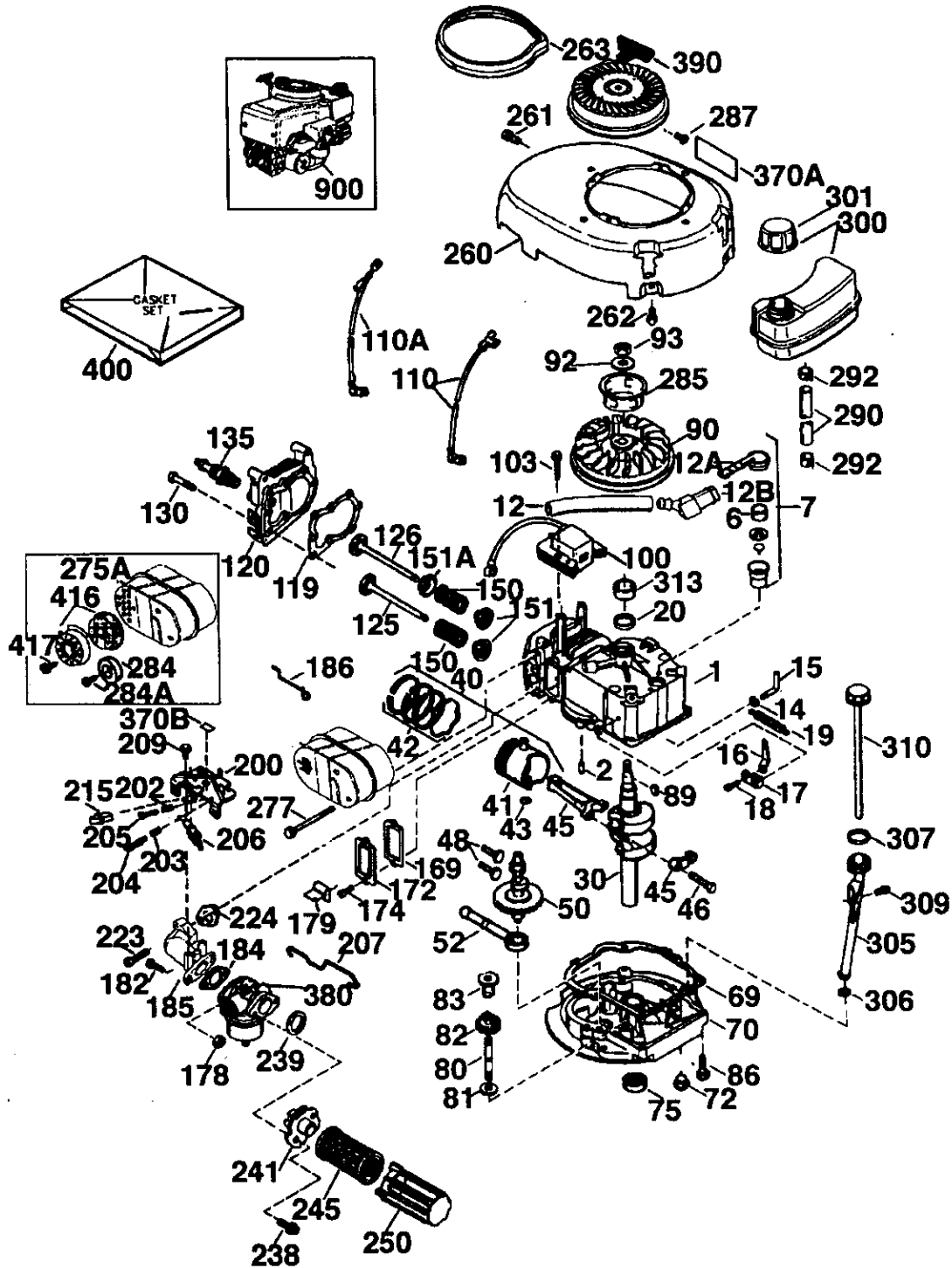

CRAFTSMAN 4-CYCLE ENGINE MODEL NUMBER: 143.983804

REF. NO.	PART NO.	PART NAME
1	37027	Cylinder (Incl. 2 & 20)
2	26727	Dowel
6	33734	Breather Element
7	36557	Breather Assy(Incl. 6 & 12A)
12	36775	Breather Tube
12A	36558	Breather Cover & Tube (Incl. 12B)
12B	36694	Breather Tube Elbow
14	28277	Washer
15	30589	Governor Rod(Incl 14)
16	34839A	Governor Lever
17	31335	Governor Lever Ciamp
18	651018	Screw, 8-32 x 19/64"
19	36281	Extension Spring
20	32600	Oil Seal
30	36833	Crankshaft
40	35544A	Piston, Pin & Ring Set(std)
40	35545A	Piston, Pin & Ring Set (0.010 OS)
40	35546	Piston, Pin & Ring Set (0.020 OS)
41	35541	Piston & Ring Assy (Std) (Incl 43)
41	35542	Piston & Pin Assy (.010" OS) Incl 43
41	35543	Piston & Pin Assy (.020" OS (Incl 43)
42	35547A	Ring Set (Std)
42	35548A	Ring Set (.010" OS)
42	35549	Ring Set (.020" OS)
43	20381	Piston Pin Retain Ring
45	36777	Connecting Rod Assy (Incl 46)
46	32610A	Connecting Rod Bolt
48	27241	Valve Lifter
50	37032	Camshaft (NCR)
52	29914	Oil Pump Assy.
69	35261	Mounting Flange Gasket
70	36995	Mounting Flange (Incl 72 thru 83)
72	36083	Oil Drain Plug
75	27897	Oil Seal
80	30574A	Governor Shaft
81	30590A	Washer
82	30591	Governor Gear Assy (Incl 81)
83	30588A	Governor Spool
86	650488	Screw 1/4-20 x 1-1/4"
89	610961	Flywheel Key
90	611213	Flywheel
92	650815	Belleville Washer
93	650816	Flywheel Nut
100	34443B	Solid State Ignition
103	651007	Screw, Torx T-15, 10-24 x 15/16"
110	36816	Ground Wire
110A	36230	Ground Wire
119	37028	Cylinder Head Gasket
120	36825	Cylinder Head
125	36779	Exhaust Valve (Std) (Incl. 151)
125	36780	Exhaust Valve (1/32" OS) (Incl 151)
126	36781	Intake Valve (Std) (Incl 151)
126	36782	Intake Valve (1/32" OS) (Incl 151)

REF. NO.	PART NO.	PART NAME
130	6021A	Screw 5/16-18 x 1-1/2"
135	35395	Resistor Spark Plug (RJ19LM)
150	35991	Valve Spring
151	31673	Valve Spring Cap
151A	40017	Intake Valve Seal
169	36783	Valve Cover Gasket
172	36784	Valve Cover
174	30200	Screw 10-24 x 9/16"
178	29752	Nut & Lock Washer 1/4-28
179	30593	Retainer Clip
182	6201	Screw 1/4-28 x 7/8"
184	26756	Carburetor to intake Pipe Gasket
185	36785	Intake Pipe
186	34337	Governor Link
200	33205A	Control Bracket (Incl. 202 thru 206)
202	36482	Compression Spring
203	31342	Compression Spring
204	651029	Screw 5-40 x 7/16"
205	651019	Screw, 6-32 x 41/64"
206	610973	Terminal
207	34336	Throttle Link
209	30200	Screw 10-32 x 9/16"
215	32410	Control Knob
223	650451	Screw 1/4-20 x 1"
224	36786	Intake Pipe Gasket
238	650932	Screw 10-32 x 49/64"
239	34338	Air Cleaner Gasket
241	35797	Air Cleaner Collar
245	35066	Air Cleaner Filter
250	35065	Air Cleaner Cover
260	36798	Blower Housing
261	30200	Screw 10-24 x 9/16"
262	650831	Screw 1/4-20 x 1/2"
263	36240	Trim Ring
275	36837	Muffler
275A	36790	Muffler (Optional)
277	650988	Screw 1/4-20 x 2-5/16"
284	36663	Muffler Deflector(In 284)
284A	650760	Screw 8-32x3/8" (Opt)
285	35000A	Starter Cup
287	650926	Screw 8-32 x 21/64"
290	34357	Fuel Line
292	26460	Fuel Line Clamp
300	35586	Fuel Tank (Incl 292 & 301)
301	35355	Fuel Cap
305	35577	Oil Fill Tube
306	36996	"O" Ring
307	35499	"O" Ring
309	650562	Screw 10-32x1/2"
310	35578	Dipstick
313	34080	Spacer
370A	36261	Lubrication Decal
370B	35169	Control Decal
380	640076	Carburetor (Incl 184)
390	590694	Rewind Starter
400	36792B	Gasket Set
417	35085	Spark Arrestor Set

This engine could have been built with 590737 starter.

CRAFTSMAN 4-CYCLE ENGINE MODEL NUMBER: 143.983804

Starter No. 590694

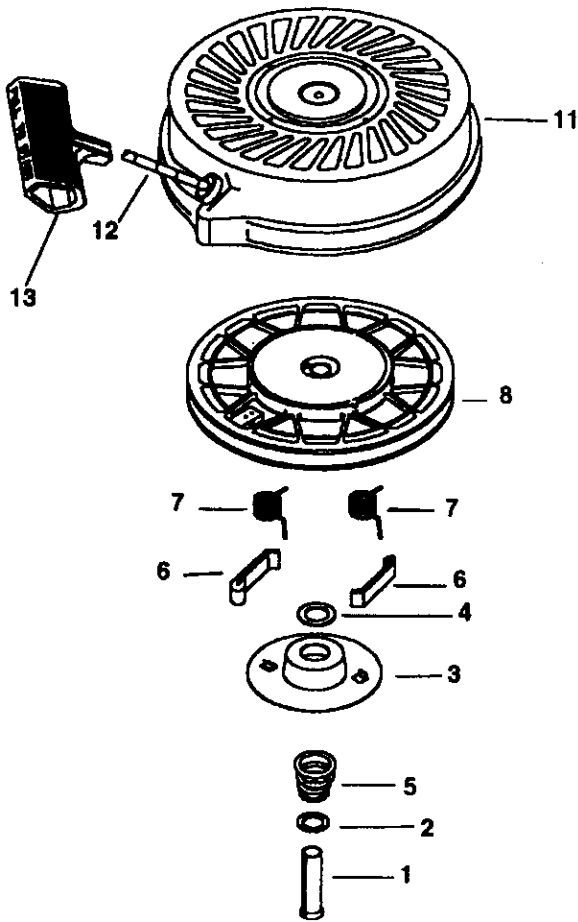

REF. NO.	PART NO.	PART NAME
1	590694	Rewind Starter
2	590599A	Spring Pin (Incl.4)
3	590600	Washer
4	590696	Retainer
5	590601	Washer
6	590697	Brake Spring
7	590698	Starter Dog
8	590699	Dog Spring
11	590700	Pulley & Rewind Sprg Assy.
	590695	Starter Housing Assy (40° grommet)
12	590535	Starter Rope
13	590701	Starter Handle

Starter No. 590737

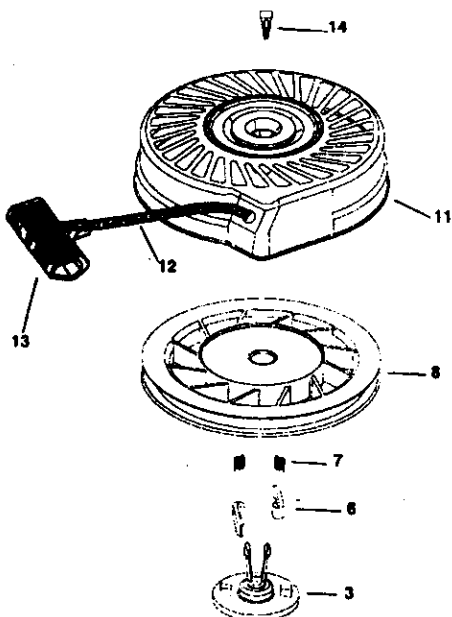

REF. NO.	PART NO.	PART NAME
3	590737	Rewind Starter
6	590740	Retainer
7	590616	Starter Dog
8	590617	Dog Spring
11	590618A	Pulley & Rewind Spring Assy
12	590687A	Starter Housing Assy
13	590535	Starter Rope
14	590701	Starter Handle
	590741	Locking Tab

CRAFTSMAN 4-CYCLE ENGINE MODEL NUMBER: 143.983804

Carburetor No.640076

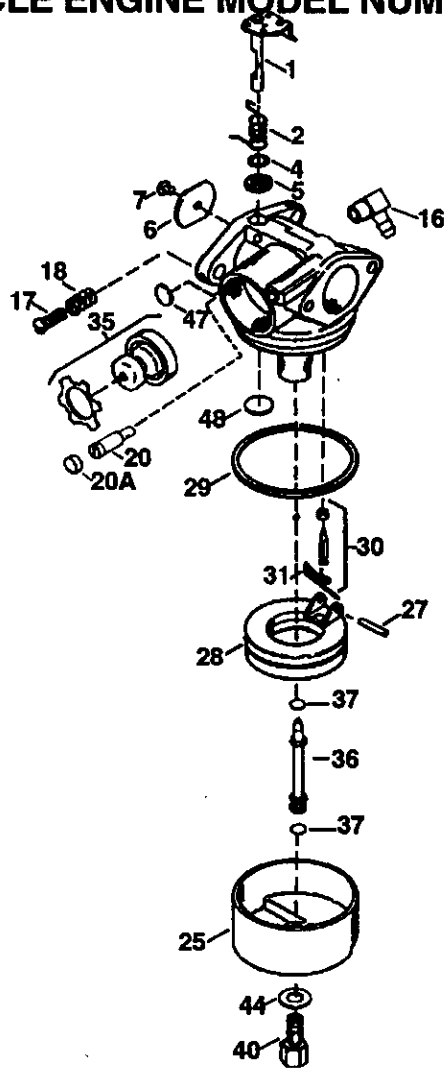

REF. NO.	PART NO.	PART NAME
0	640076	Carburetor (Incl. 184 of Engine Parts List)
1	631615	Throttle Shaft & Lever Ass'y.
2	631767	Throttle Return Spring
4	631184	Dust Seal Washer
5	631183	Dust Seal (Throttle)
6	631036	Throtter Shutter
7	650506	Shutter Screw
16	632527	Fuel Fitting
17	651025	Throttle Crack Screw/Idle Speed Screw
18	630766	Tension Spring
20	640027	Idle Restrictor Screw
20A	640053	Idle Restrictor Screw Cap
25	631867	Float Bowl
27	631024	Float Shaft
28	632019	Float
29	631028	Float Bowl "O" Ring
30	631021	Inlet Needle, Seat, Clip (incl 31)
31	631022	Spring Clip
35	36045A	Primer Bulb/Retainer Ring
36	632735	Main Nozzle Tube
37	632547	"O" Ring, Main Nozzle Tube
40	640030	High Speed Bowl Nut
44	27110	Bowl Nut Washer
47	630748	Welch Plug, Idle Mixture Well
48	631027	Welch Plug Atmospheric Vent

For the repair or replacement parts you need delivered directly to your home
Call 7 am-7 pm, 7 days a week
1-800-366-PART

(1-800-366-7278)

Para ordenar piezas con entrega a domicilio -1-800-659-7084

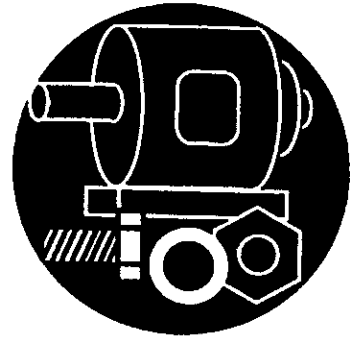

For in-house major brand repair service
Call 24 hours a day, 7 days a week
1-800-4-REPAIR

(1-800-473-7247)

Para pedir servicio de reparación a domicilio - 1-800-676-5811



For the location of a Sears Parts and Repair Center in your area
Call 24 hours a day, 7 days a week
1-800-488-1222



For information on purchasing a Sears Maintenance Agreement or to inquire about an existing Agreement
Call 9 am-5 pm, Monday-Saturday
1-800-827-6655



When requesting service or ordering parts, always provide the following information:

- Product Type
- Part Number
- Model Number
- Part Description

SEARS
REPAIR SERVICES

America's Repair Specialists

Printed in U.S.A.

Free Manuals Download Website

<http://myh66.com>

<http://usermanuals.us>

<http://www.somanuals.com>

<http://www.4manuals.cc>

<http://www.manual-lib.com>

<http://www.404manual.com>

<http://www.luxmanual.com>

<http://aubethermostatmanual.com>

Golf course search by state

<http://golfingnear.com>

Email search by domain

<http://emailbydomain.com>

Auto manuals search

<http://auto.somanuals.com>

TV manuals search

<http://tv.somanuals.com>