

SEARS / CRAFTSMAN®

Owners Manual

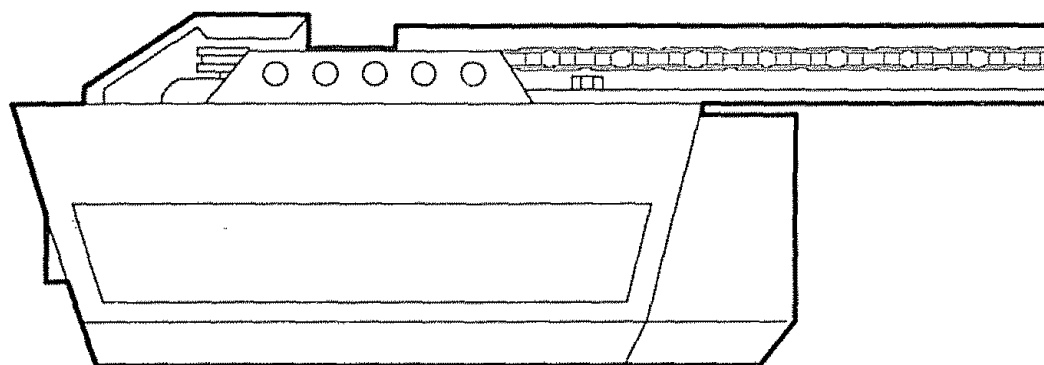

Garage Door Opener

CAUTION
PLEASE READ THIS
MANUAL CAREFULLY

Model 139.53315SR - 1/3HP
Model 139.53415SR - 1/2HP
Model 139.53615SR - 1/2HP
Model 139.53625SR - 1/2HP
Model 139.53699SR - 1/2HP

**FASTEN THIS MANUAL NEAR THE GARAGE DOOR AFTER
INSTALLATION. PERIODIC CHECKS OF THE OPENER ARE
REQUIRED TO INSURE SATISFACTORY OPERATION.**

FOR RESIDENTIAL USE ONLY.

CONTENTS	PAGE
Safety Rules	2
Operation of Your Opener	3
Maintenance Schedule	3
Features of Your Opener	4
Specifications	4
Accessories	4
Carton Check List	5
You'll Need Tools	5
Assembly	6
Installation Information	9
Installation	10
Force & Limit Adjustment	17
Safety Reverse Test	18
Setting/Changing Code	19
Having a Problem ?	20
Repair Parts, Rail Assembly	22
Repair Parts, Installation	22
Repair Parts, Chassis Assembly ..	23
How To Order Repair Parts	24
Maintenance Agreements	24
Sears Warranty	24

Start By Reading These Important Safety Rules



THIS SAFETY ALERT SYMBOL MEANS **CAUTION** — PERSONAL SAFETY OR PROPERTY DAMAGE INSTRUCTION. READ THESE INSTRUCTIONS CAREFULLY.

THIS GARAGE DOOR OPENER IS DESIGNED AND TESTED TO OFFER REASONABLY SAFE SERVICE PROVIDED IT IS INSTALLED AND OPERATED IN STRICT ACCORDANCE WITH THE FOLLOWING SAFETY INSTRUCTIONS.

FAILURE TO COMPLY WITH THE FOLLOWING INSTRUCTIONS MAY RESULT IN SERIOUS PERSONAL INJURY OR PROPERTY DAMAGE.

CAUTION: IF YOUR GARAGE HAS NO SERVICE ENTRANCE DOOR, INSTALL MODEL 53702 EMERGENCY RELEASE KEYLOCK (PAGE 4). THIS ACCESSORY ALLOWS MANUAL OPERATION OF GARAGE DOOR FROM OUTSIDE IN CASE OF POWER FAILURE.



KEEP GARAGE DOOR BALANCED. Sticking or binding doors must be repaired. Garage doors, door springs, cables, pulleys, brackets and their hardware are under extreme tension and can cause serious personal injury. **DO NOT ATTEMPT TO LOOSEN, MOVE OR ADJUST THEM.** Call a garage door serviceman.



THE SAFETY REVERSE SYSTEM TEST IS VERY IMPORTANT (page 18). Your garage door **MUST** reverse on contact with a 1" obstacle placed on the floor. Failure to properly adjust the opener may result in serious personal injury from a closing garage door. **REPEAT THE TEST AT LEAST ONCE EVERY THREE MONTHS AND MAKE NEEDED ADJUSTMENTS.**



DO NOT WEAR RINGS, WATCHES OR LOOSE CLOTHING while installing or servicing a garage door opener.



Fasten the **CAUTION LABEL** adjacent to Lighted Push Button as a reminder of safe operating procedures.



To avoid serious personal injury from entanglement, **REMOVE ALL ROPES CONNECTED TO THE GARAGE DOOR** before installing the garage door opener.



Install Lighted Push Button (or any additional push buttons) IN A LOCATION WHERE THE GARAGE DOOR IS VISIBLE, BUT OUT OF THE REACH OF CHILDREN. **DO NOT ALLOW CHILDREN TO OPERATE THE WALL PUSH BUTTON(S) OR TRANSMITTER.** Serious personal injury from a closing garage door may result from misuse of the opener.



DISENGAGE ALL EXISTING GARAGE DOOR LOCKS to avoid damage to garage door.



CAUTION: Activate opener only when the door is in full view, free of obstructions and opener is properly adjusted. NO ONE SHOULD ENTER OR LEAVE THE GARAGE WHILE DOOR IS IN MOTION. DO NOT ALLOW CHILDREN TO PLAY NEAR THE DOOR.



Installation and wiring must be in compliance with your local building and electrical codes. **CONNECT THE POWER CORD ONLY TO A PROPERLY GROUNDED OUTLET.**



LIGHTWEIGHT FIBERGLASS, ALUMINUM AND STEEL DOORS MUST BE SUBSTANTIALLY REINFORCED TO AVOID DOOR DAMAGE. (See page 15.) The best solution is to check with your garage door manufacturer for an opener installation reinforcement kit.



Use the emergency release **ONLY** to disengage the trolley and, if possible, **ONLY** when the door is closed. **DO NOT USE THE RED EMERGENCY HANDLE TO PULL DOOR OPEN OR CLOSED.**



DO NOT USE THE FORCE ADJUSTMENTS TO COMPENSATE FOR A BINDING OR STICKING GARAGE DOOR. Excessive force will interfere with the proper operation of the safety reverse system or damage the garage door (page 17).



DISCONNECT ELECTRIC POWER TO GARAGE DOOR OPENER BEFORE MAKING REPAIRS OR REMOVING COVERS.

Operation of Your Opener

CAUTION

- **BEFORE YOU PROCEED, PLEASE READ THE SAFETY RULES ON PAGE 2 AND OPERATING INSTRUCTIONS ON THIS PAGE CAREFULLY.**
- **TO AVOID DIFFICULTY DURING INSTALLATION, DO NOT RUN OPENER UNTIL INSTRUCTED TO DO SO.**
- **DO NOT PERMIT CHILDREN TO PLAY IN DOOR AREA.**
- **OPERATE ONLY WHEN OPENER IS PROPERLY ADJUSTED AND THE DOOR IS VISIBLE AND UNOBSTRUCTED.**

USING THE OPENER

Your opener can be activated by any of the following devices:

1. **The 3-Function Transmitter.** Hold the **LARGE** push button down until the door starts to move.
2. **The Wall Push Button.** Hold push button down until the door starts to move.
3. **The Key Switch or Touch Code Transmitter accessories.** Described on page 4.

OPENING THE DOOR MANUALLY

THE DOOR SHOULD BE FULLY CLOSED IF POSSIBLE. WEAK OR BROKEN SPRINGS COULD ALLOW AN OPEN DOOR TO FALL RAPIDLY. PROPERTY DAMAGE OR SERIOUS PERSONAL INJURY COULD RESULT. DO NOT USE EMERGENCY HANDLE TO PULL DOOR OPEN OR CLOSED.

The door can be operated manually by disconnecting it from the opener. Pull down sharply on the red emergency release handle and lift the door manually. To automatically reconnect the door to the opener, press the Wall Push Button.

LOCKOUT FEATURE: prevents trolley from reconnecting automatically. If you need to use this feature, pull emergency handle down and back (toward the opener). Trolley will remain "Locked-Out" and door can be raised and lowered manually. To reconnect trolley, pull emergency handle straight down.

WHEN OPENER IS ACTIVATED:

1. If open, the door will close. If closed, the door will open.
2. If closing, the door will reverse
3. If opening, the door will stop (allowing space for entry and exit of pets and for fresh air).
4. If the door has been stopped in a partially open position, it will close.
5. If an obstruction is encountered while closing, the door will reverse.
6. If an obstruction is encountered while opening, the door will stop.
7. If the optional 'Infrared Sensor' is installed, the garage door will reverse in the closing cycle when the invisible beam is broken. An open door will not close when beam is broken. The sensor has no effect in the opening cycle.

OPENER LIGHT will turn on under the following conditions: when the opener is initially plugged in; when the power is interrupted; when the opener is activated. It will turn off automatically after 4½ minutes. Bulb size 75 watts maximum.

CARE OF THE OPENER

When properly installed, opener will provide high performance with a minimum of maintenance. The opener does not require additional lubrication.

Most complaints of unsatisfactory opener operation can be traced to problems with the door itself. When operated manually, a properly balanced door will stay in any point of travel while being supported entirely by its springs.

THE OPENER IS NOT INTENDED TO CORRECT ANY PROBLEMS THAT ARE CAUSED BY AN UNBALANCED OR BINDING DOOR, BROKEN DOOR SPRINGS OR BY FAULTY DOOR HARDWARE.

LIMIT AND FORCE ADJUSTMENTS: These adjustments must be checked and properly set when opener is installed. Only a screwdriver is required. Page 17 refers to the limit and force adjustments. Follow instructions carefully.

REPEAT SAFETY REVERSE TEST AFTER ANY ADJUSTMENT OF FORCE AND/OR LIMITS. Weather conditions may cause some minor changes in door operation requiring some readjustments, particularly during the first year of operation.

THE SAFETY REVERSE SYSTEM IS IMPORTANT (See pg. 18). GARAGE DOOR **MUST REVERSE ON CONTACT WITH A ONE-INCH OBSTACLE PLACED ON THE FLOOR.** FAILURE TO PROPERLY ADJUST OPENER MAY RESULT IN SERIOUS PERSONAL INJURY FROM A CLOSING GARAGE DOOR.

CHAIN TENSION ADJUSTMENT: After installation of the opener and adjustment of forces and limits, the chain may appear loose. This is normal. To check the chain tension: disconnect the trolley by pulling the red emergency handle. If the chain returns to the position described and illustrated in Step 5 page 9, DO NOT make ANY further adjustments.

TRANSMITTER: The 3-function transmitter will operate more than one garage door opener, if desired. The push buttons may also be used to operate other 53000 and/or 53000SR Series devices. The standard transmitter may be secured to car sun visor with clip provided. Additional transmitters can be purchased at any time. Refer to Accessories on page 4.

Any new transmitters must be set to the same code as the original transmitter and receiver. Page 19 explains how to change your existing code and use the transmitter(s) with other 53000 and/or 53000SR Series receivers. Self service of your radio controls is not recommended. If service is needed, contact your nearest Sears Service Center.

TRANSMITTER BATTERY: The 12 Volt battery should produce power for at least one year. As long as the battery power is adequate, the transmitter test light will glow when the push button is pressed (and the opener or other control will operate). If light doesn't come on, replace the battery. If transmission range lessens, check battery test light.

TO CHANGE BATTERY: Slide the battery compartment cover down (or remove cover screw). Position new 12Volt battery as directed.

MAINTENANCE OF YOUR OPENER

AT LEAST 4 TIMES A YEAR

MANUALLY OPERATE DOOR. If it is unbalanced or binding, call for professional garage door service.

CHECK TO BE SURE DOOR OPENS & CLOSSES FULLY. Adjust Limits and/or Force if necessary.

REPEAT SAFETY REVERSE TEST. Make any necessary adjustments (see page 18).

TWICE A YEAR

CHECK CHAIN TENSION. Adjust if necessary.

ONCE A YEAR

OIL DOOR ROLLERS, BEARINGS AND HINGES.

FEATURES OF YOUR OPENER

- Motor:** Permanently lubricated with automatic reset.
- Opener Light:** Turns on and off automatically with 4½ minute illumination for your safety and convenience.
- Safety System:** Independent up and down force adjustment. The door reverses automatically when obstructed in DOWN direction. The door STOPS when obstructed in UP position
- Easy Limit Adjustment:** Limits of door opening and closing adjusted by turning screws without removing chassis cover.
- Digital Radio Controls:** The code can be easily changed by the owner.
- 3-Function Transmitter:** Has three push buttons. Each button can activate one or more Light Control and/or garage door opener. The opener receiver is factory preset to activate with LARGE transmitter push button.
- Emergency Disconnect:** Pull cord disconnect permits manual door operation.
- Automatic Reconnect:** The trolley halves reconnect for automatic operation when the opener is energized after emergency disconnect.

SPECIFICATIONS

MOTOR	
Type	Permanent split capacitor
Speed	1500 rpm
Volts	120 Volts AC - 60 Hz. Only
Current	4.5 amperes
DRIVE MECHANISM	
Gears	16:1 worm gear reduction
Drive	Chain & cable with two-piece trolley on steel Tee-rail
Length of travel	Adjustable to 7½ feet
Travel rate	6 to 8 inches per second
Lamp	On when door starts in travel, off 4½ minutes after stop.
Door linkage	Adjustable door arm. Pull cord trolley release

SAFETY





Personal	Push button and automatic reversal in down direction. Push button and Automatic stop in UP direction
Electronic	Independent UP and DOWN force adjustment screws
Electrical	Motor overload protector & low voltage push button wiring
Limit device	Circuit actuated by limit nut
Limit adjustment	Screwdriver adjustment on side panel
Start circuit	Low voltage push button or radio control

DIMENSIONS

Length (overall)	124 inches
Headroom required	2 inches
Hanging weight	32 pounds

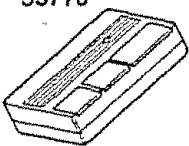
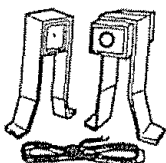
ACCESSORIES

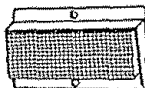
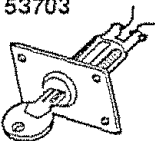
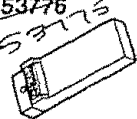
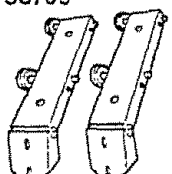
Sears offers many useful accessories for your garage door opener. They are illustrated below with Sears stock numbers and descriptions.

53778 	EXTRA TRANSMITTER: Standard size. Includes visor clip.	53710 	INFRARED REVERSING SENSOR: An optional system which provides auxiliary support to the safety features built into your opener. If the system's invisible beam is broken, a closing door will reverse and an open door will not close.
53758 	EXTRA TRANSMITTER: Mini, with key ring.	53717 	OPEN DOOR INDICATOR: Provides an illuminated signal when your garage door is open.
53703 	OUTDOOR KEY SWITCH: Opens the garage door automatically from outside when transmitter is not handy.	53776 	TOUCH CODE TRANSMITTER: Enables homeowner to operate garage door opener from outside by entering code on specially designed keyboard.
53709 	DOOR CLEARANCE BRACKETS: (For Sectional Doors Only) Replace top brackets and rollers on door to reduce height of door travel. For use when installing opener in garage with low headroom clearance.	53702 	EMERGENCY RELEASE KEYLOCK REQUIRED for a garage with NO service door. Allows manual operation of garage door from outside in case of power failure.

CARTON CHECK LIST

SEARS has packaged your GARAGE DOOR OPENER in two cartons which contain all the parts and hardware illustrated below and on Page 22.

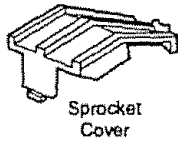

Sprocket
Cover



Rail
Grease

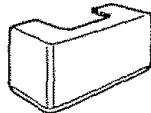

Light
Lens

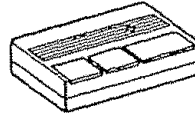

Transmitters (2),
except 53415, 53315
& 53899 (1 only)

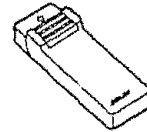

Touch Code
Transmitter
139.53625 ONLY



Mini
Transmitter
139.53699 ONLY

SEPARATE ALL HARDWARE FOR ASSEMBLY AND INSTALLATION PROCEDURES AS SHOWN BELOW.

ASSEMBLY HARDWARE



Threaded Trolley Rod
(1)



Master Link
(2)

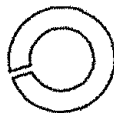

Lockwasher
5/16" (4)

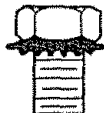

Washed Screw
5/16" - 18 x 1/2"
(2)
*(mounted
in chassis)



Nut
5/16" - 18
(5)



Carriage Bolt
1/4" - 20 x 1/2"
(4)



Lock Nut
1/4" - 20 x 1/2"
(4)

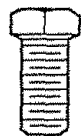

Hex Screw
5/16" - 18 x 7/8"
(3)

INSTALLATION HARDWARE



Clevis Pin
5/16" x 2-3/4"
(1)

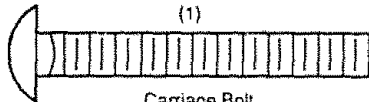

Carriage Bolt
5/16" - 18 x 2-1/2"
(2)

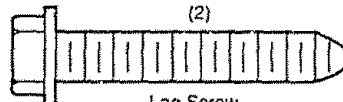

Lag Screw
5/16" - 18 x 1-7/8"
(4)



Sheet Metal Screw
6AB x 1"
(2)

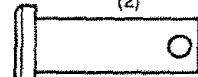

Clevis Pin
5/16" x 1"
(2)



Hex Screw
5/16" - 18 x 7/8"
(4)



Ring
Fastener (3)



Rope



Handle



Insulated
Staples (10)



Anchors (2)



Lockwasher
5/16" (6)



Nut
5/16" - 18
(6)

YOU'LL NEED TOOLS

During assembly and installation of your opener, the instructions will call for the use of various hand tools. Have a stepladder handy, and those tools illustrated below; hammer, electric drill (& 3/16" and 5/16" drill bits), screwdriver, adjustable end wrench or socket wrench kit, wire cutters, tape measure, pliers and hack saw.

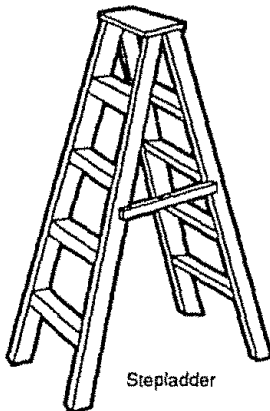

Stepladder

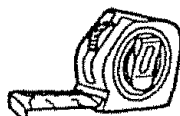

Tape Measure

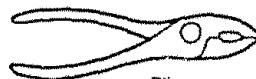

Pliers

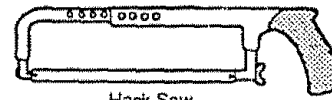

Hack Saw

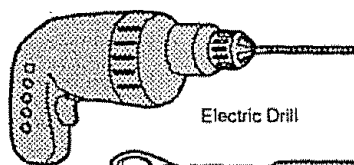

Electric Drill



Wire Cutters



Claw Hammer

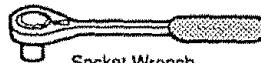

Socket Wrench

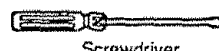

Screwdriver

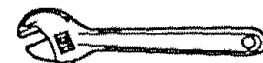

Adjustable End Wrench

Assembly

TO AVOID INSTALLATION DIFFICULTIES, DO NOT RUN THE GARAGE DOOR OPENER UNTIL INSTRUCTED TO DO SO.

STEP 1 Assemble Tee Rail & Attach Cable Pulley Bracket

CAUTION: Do not tighten the lock nuts until bolt necks are seated in square holes.

The end sections of the rail MUST be connected to the center section from the direction shown in the illustration. Otherwise, the trolley will hit against the nut when installed (Pg. 7).

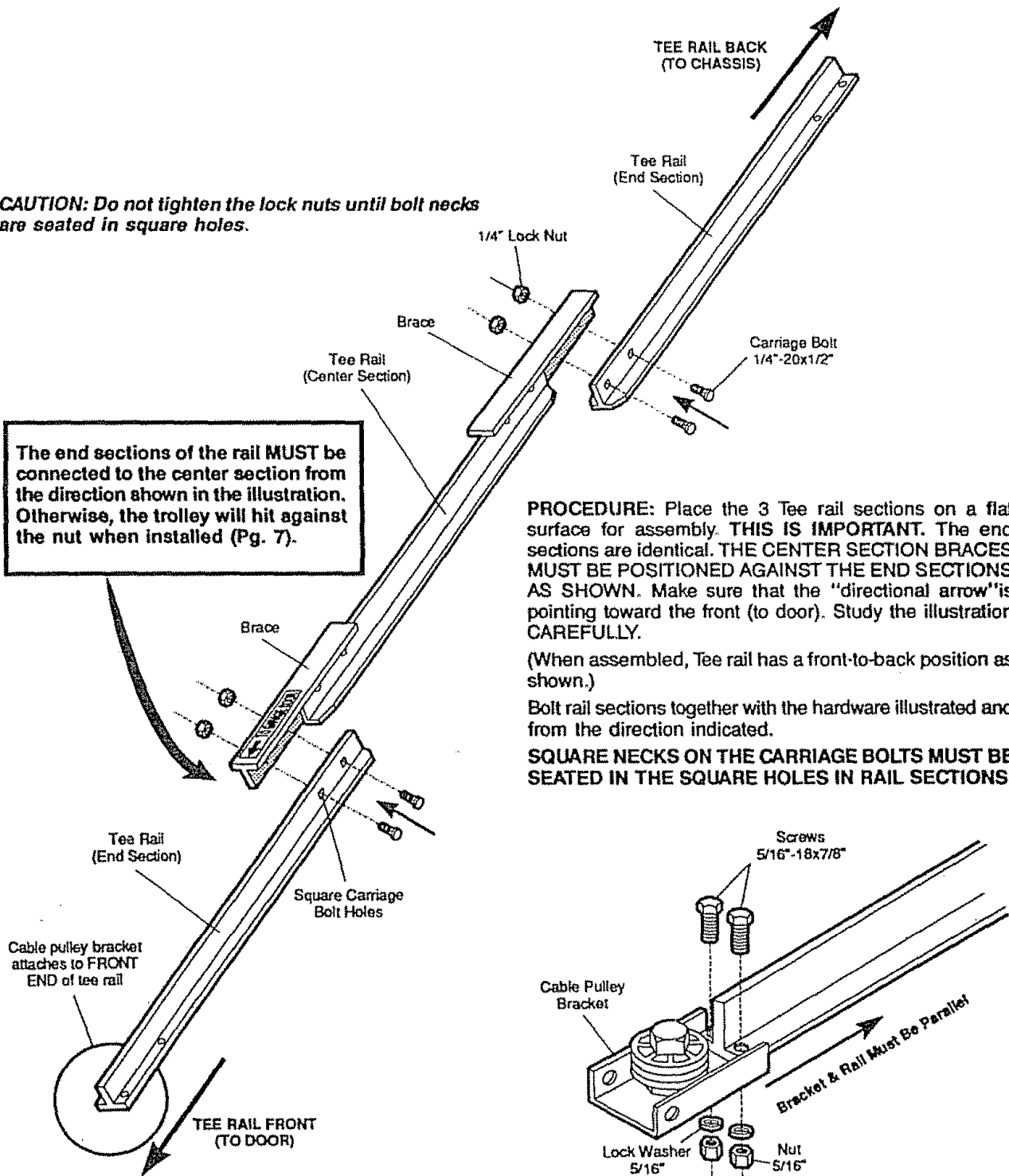

PROCEDURE: Place the 3 Tee rail sections on a flat surface for assembly. **THIS IS IMPORTANT.** The end sections are identical. THE CENTER SECTION BRACES MUST BE POSITIONED AGAINST THE END SECTIONS AS SHOWN. Make sure that the "directional arrow" is pointing toward the front (to door). Study the illustration CAREFULLY.

(When assembled, Tee rail has a front-to-back position as shown.)

Bolt rail sections together with the hardware illustrated and from the direction indicated.

SQUARE NECKS ON THE CARRIAGE BOLTS MUST BE SEATED IN THE SQUARE HOLES IN RAIL SECTIONS.

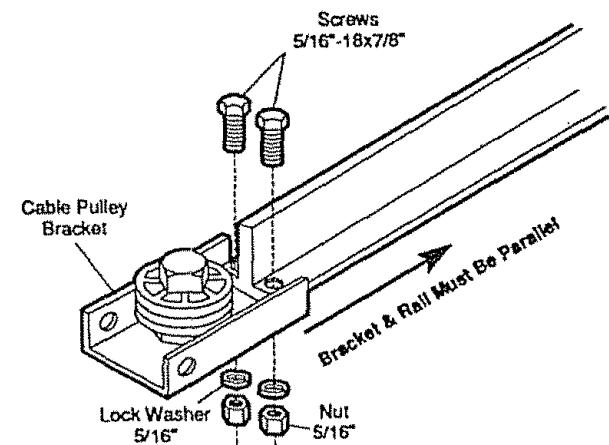

Position the cable pulley bracket on front end of tee rail as shown. Fasten securely with the hardware provided. **IMPORTANT:** When tightening screws, be sure to keep bracket parallel to rail. Otherwise, rail may bow when opener is operated.

Assembly

STEP 2 Install Trolley

AS A TEMPORARY STOP, INSERT A SCREWDRIVER INTO HOLE IN FRONT END OF TEE RAIL AS SHOWN.

1. Attach threaded shaft to trolley with lockwasher and nuts as shown.
2. Slide trolley assembly along rail to screwdriver stop.

NOTE: If trolley hits against the nut on Tee rail, center section was attached from wrong side and must be repositioned. Review Step 1.

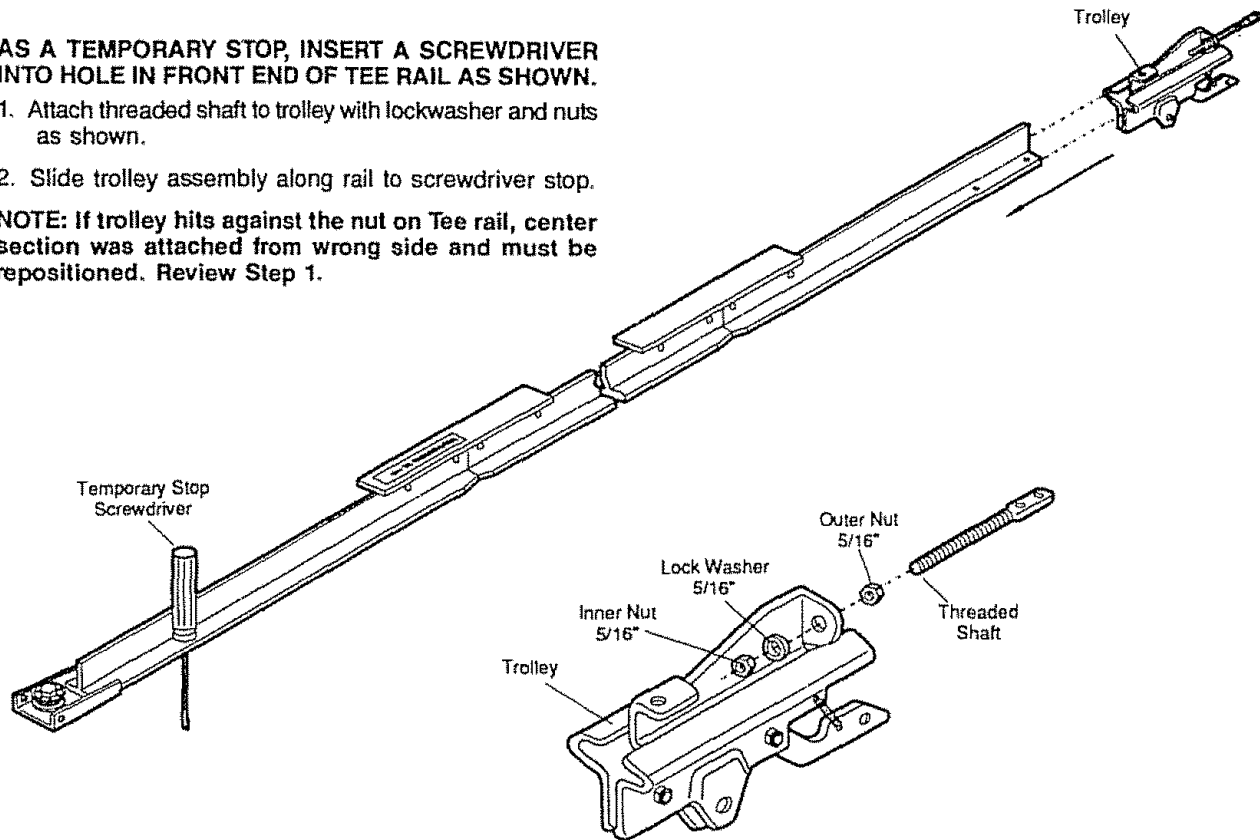

STEP 3 Attach Tee Rail To Opener Chassis



USE ONLY THOSE SCREWS MOUNTED IN TOP OF OPENER CHASSIS. FAILURE TO DO SO WILL CAUSE SERIOUS DAMAGE TO THE OPENER.

PROCEDURE: Place the opener chassis on packing material to protect the cover. For convenience, place a support under the cable pulley bracket.

Remove 5/16"-18 x 1/2" washered screws mounted in top of opener chassis. Align holes in back end of Tee rail with holes in opener chassis. Fasten the rail to the chassis with washered screws previously removed. **CAUTION: USE ONLY THESE SCREWS!** Use of any other screws will cause serious damage to door opener. Tighten screws securely.

Insert a 5/16"-18 x 7/8" washered screw into trolley stop hole in the Tee rail as shown. Tighten securely with a 5/16" lockwasher and nut.

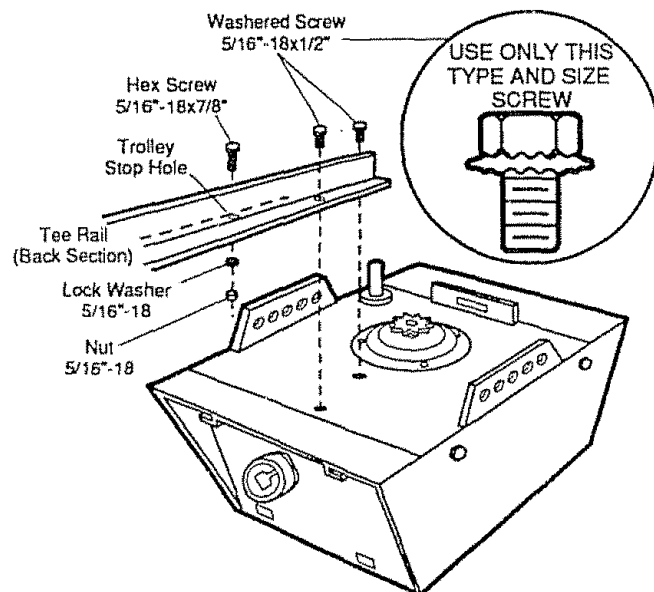

Assembly

STEP 4 Install Chain and Cable

DO NOT REMOVE CHAIN AND CABLE FROM CARTON.

Detach cable from side of carton and fasten to trolley with a master link from coin envelope.

MASTER LINK PROCEDURE: Push pins of master link bar through loop of cable and hole in front end of trolley (A) as shown. Push cap over pins and onto notches. Slide clip-on spring over cap and onto pin notches until both pins are locked in place.

Caution: Keep the chain taut while installing to help prevent kinking.

With trolley against the screwdriver, dispense cable around pulley. Proceed back around opener sprocket (B)- be sure sprocket teeth engage chain- and forward to the threaded trolley shaft (C).

Use second master link to connect the chain to the flat end of shaft as shown. Check to make sure chain is not twisted.

REMOVE SCREWDRIVER.

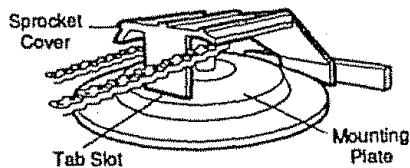
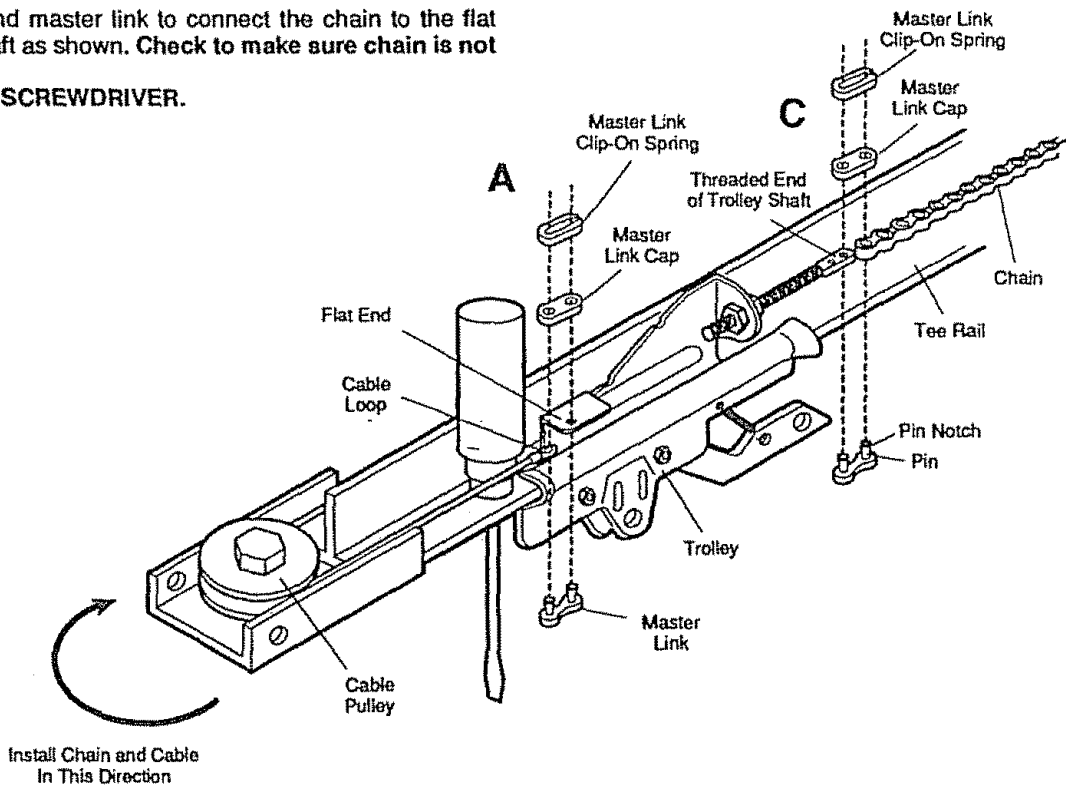
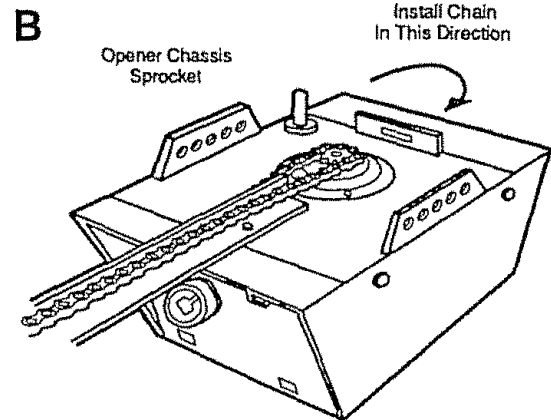

ATTACH SPROCKET COVER TO CHASSIS: Insert back tab in chassis slot. Then bend cover forward and insert front tab in slot provided on mounting plate.

Assembly

STEP 5 Tighten the Chain and Cable

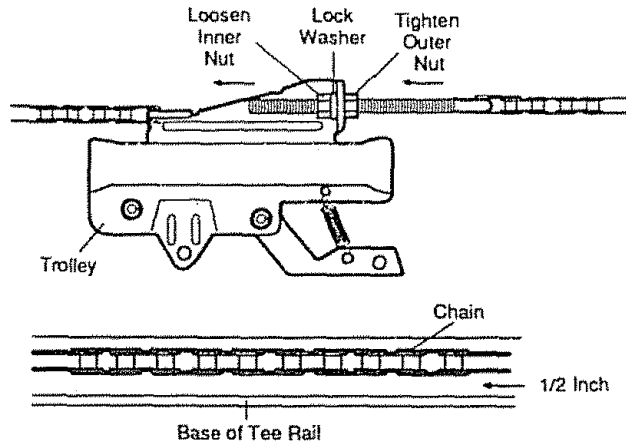

CAUTION: Keep the chain from twisting as nuts are turned.

PROCEDURE: Thread the outer nut toward trolley as shown. (Loosen inner nut first, if necessary.)

Tension is correct when the chain is approximately 1/2" above the base of the Tee rail, midway between pulley bracket and chassis.

To maintain proper tension, make sure inner nut is re-tightened.

Sprocket noise can result if chain is either too loose or too tight.

CAUTION: Do not overtighten the chain. Refer to Page 3.

ASSEMBLY OF YOUR GARAGE DOOR OPENER IS NOW COMPLETE.

BEFORE YOU PROCEED WITH THE INSTALLATION OF YOUR GARAGE DOOR OPENER, BE SURE TO COMPLY WITH ALL SAFETY RULES.



KEEP GARAGE DOOR BALANCED. STICKING OR BINDING DOORS MUST BE REPAIRED. THE GARAGE DOOR, DOOR SPRINGS, CABLES, PULLEYS, BRACKETS AND THEIR HARDWARE ARE UNDER EXTREME TENSION AND CAN CAUSE SERIOUS PERSONAL INJURY. DO NOT ATTEMPT TO LOOSEN, MOVE OR ADJUST THEM. CALL A GARAGE DOOR SERVICEMAN.



DO NOT WEAR WATCHES, RINGS OR LOOSE CLOTHING WHILE INSTALLING OR SERVICING A DOOR OPENER.

AS YOU PROCEED WITH THE REMAINING INSTRUCTIONS IN THIS OWNERS MANUAL, YOU MAY FIND IT HELPFUL TO REFER TO THE FOLLOWING ILLUSTRATION OF THE FULLY ASSEMBLED AND INSTALLED GARAGE DOOR OPENER.

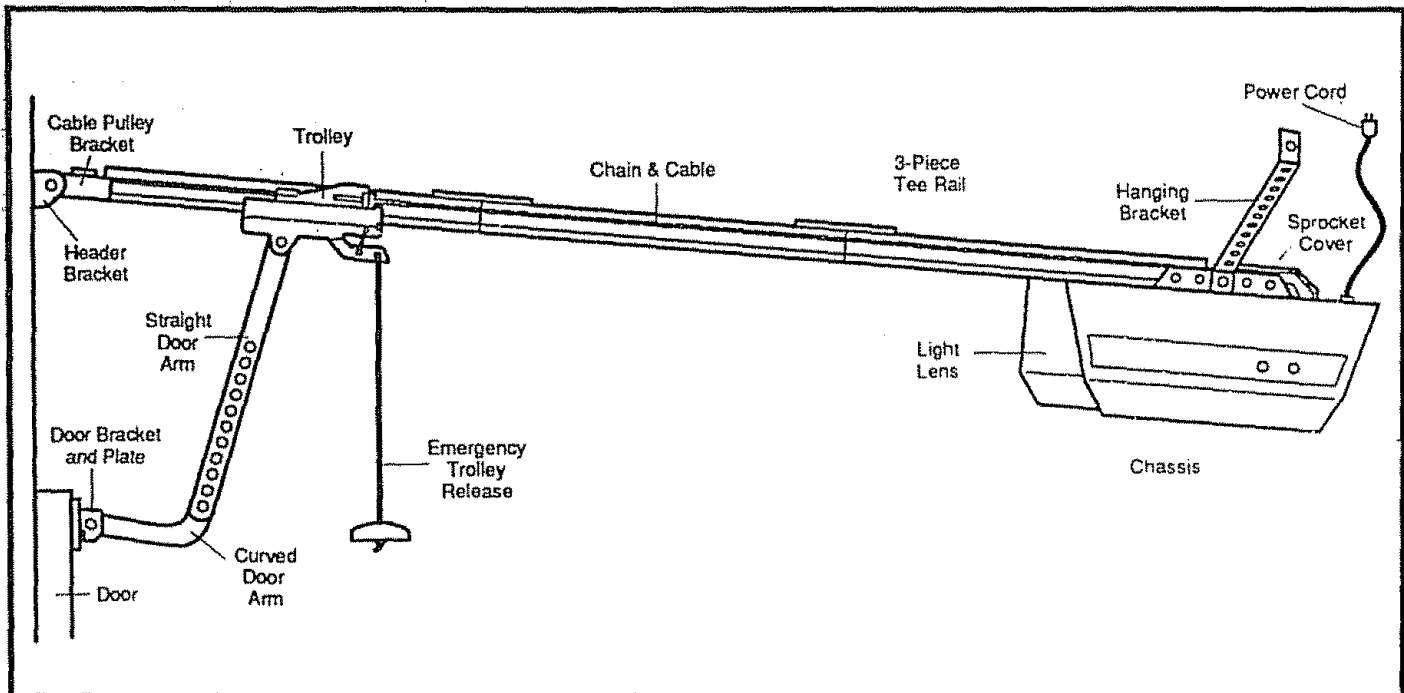

IT IS RECOMMENDED THAT THE OPENER BE INSTALLED 7 FEET OR MORE ABOVE FLOOR WHERE SPACE PERMITS. CERTAIN INSTALLATION PROCEDURES VARY ACCORDING TO GARAGE DOOR TYPES. WHERE THE DIFFERENCES OCCUR, BE SURE TO FOLLOW ONLY THOSE INSTRUCTIONS WHICH APPLY TO YOUR DOOR CONSTRUCTION.

Installation

STEP 1

Position and Install Header Bracket

Installation procedures vary according to garage door types. Follow only those instructions which apply to your door as illustrated.



THE HEADER BRACKET MUST BE RIGIDLY FASTENED TO THE HEADER WALL. REINFORCE THE WALL WITH 2x4 IF NECESSARY. FAILURE TO COMPLY MAY RESULT IN IMPROPER OPERATION OF SAFETY REVERSE SYSTEM (SEE PAGE 18).

1. With the door closed, locate and mark the vertical centerline of garage door. Extend line onto header wall above the door.
2. Locate height for header bracket by opening door to highest point of travel as shown. Draw an intersecting horizontal line on header wall 2" above high point. This height provides travel clearance for top edge of door.

NOTE: When the headroom is not sufficient for 2" clearance, the bottom edge of bracket may be placed parallel to the high point of travel.

Door Clearance Brackets are designed for low headroom installations (page 4). They replace top brackets and rollers on the garage door, thereby lowering the high point of door travel. Installation instructions are contained in the accessory carton.

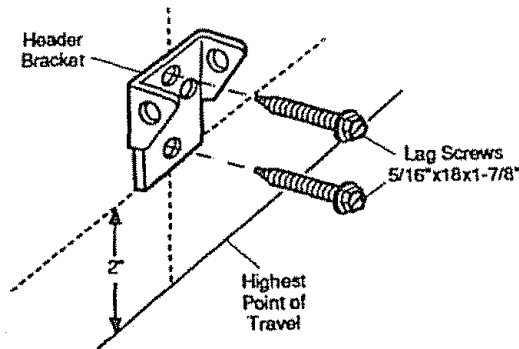

INSTALLATION SECTIONAL DOOR AND 1-PIECE DOOR WITH TRACK

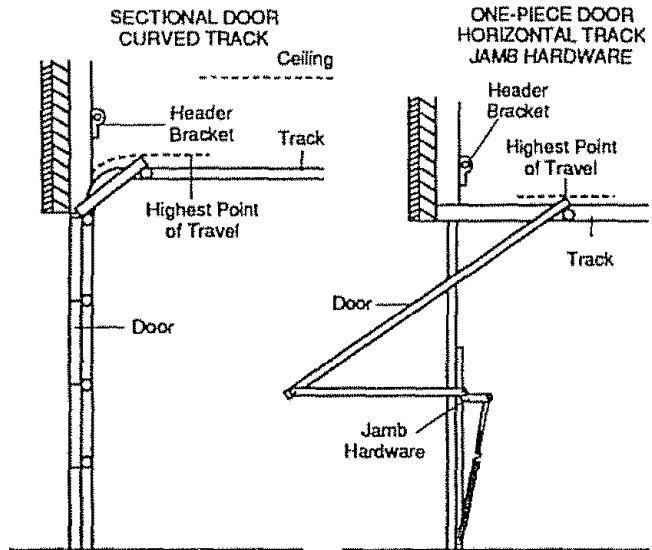

3. Position bracket as shown (bottom edge of bracket on horizontal line). Mark either top and bottom or left and right bracket holes. Drill 3/16" pilot holes and fasten bracket.

INSTALLATION 1-PIECE DOOR WITHOUT TRACK

ONE PIECE DOOR
NO TRACK
PIVOT HARDWARE

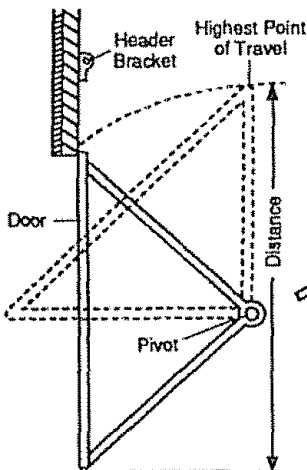

ONE PIECE DOOR
NO TRACK
JAMB HARDWARE

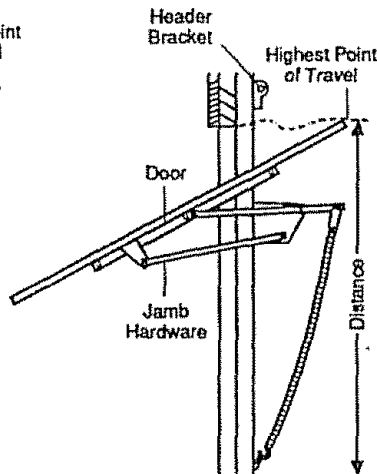

1. Follow instructions as described in 1 above.
2. Locate height for header bracket by opening door to highest point of travel as shown. Measure the distance from top of door to floor. Subtract actual height of door. Add 8" to the remainder. Refer to example below.

NOTE: If total number of inches exceeds the height available in your garage, use the maximum height possible. On finished ceilings, do not position the bracket closer than 1/2" from ceiling.

3. Measuring from top of door draw an intersecting horizontal line on the header wall at determined height. Position the bottom edge of header bracket on the horizontal line, centering bracket on vertical line. Mark either top and bottom or left and right holes. Drill 3/16" pilot holes and fasten the bracket with 5/16" x 1-7/8" lag screws as shown above.

EXAMPLE

Distance from top of door (at highest point of travel) to floor	92"
Actual height of door	-88"
Remainder	4"
Add	+ 8"
Bracket height on header wall	= 12"

(Measure UP from top of door in closed position.)

Installation

STEP 2 Attach Tee Rail to Header Bracket

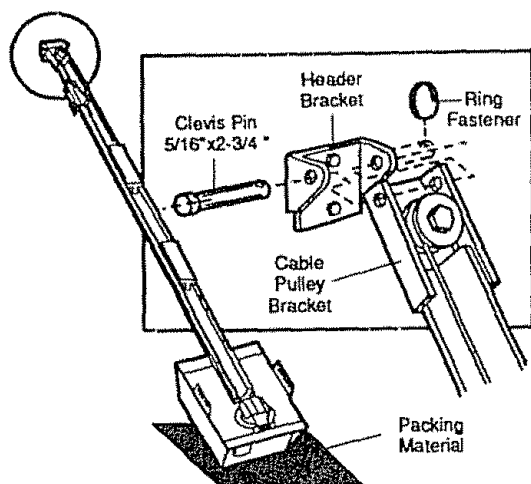

PROCEDURE: Position opener chassis on garage floor below the header bracket. Use packing material base to protect cover. **NOTE:** To enable the Tee rail to clear sectional door springs, it may be necessary to lift the chassis onto a temporary support.

CAUTION: Chassis must either be secured to support or held firmly in place by another person.

Raise the Tee rail until pulley and header brackets come together. Align bracket holes and join with clevis pin as shown. Insert ring fastener to secure.

STEP 3 Position Opener Chassis

Follow instructions which apply to your door type as illustrated.



TO PREVENT DAMAGE TO ALL LIGHTWEIGHT DOORS AND DOORS WITH WINDOWS, DO NOT REST THE OPENER ON THE DOOR.

INSTALLATION SECTIONAL & ONE-PIECE DOOR WITH TRACK

NOTE: A 2x4 is convenient for setting an ideal door-to-Tee rail distance. It is not necessary where headroom is insufficient.

PROCEDURE: Raise the opener chassis onto a stepladder. Open garage door. Place a 2x4 on top section of door near centerline as shown below. Rest Tee rail on 2x4.

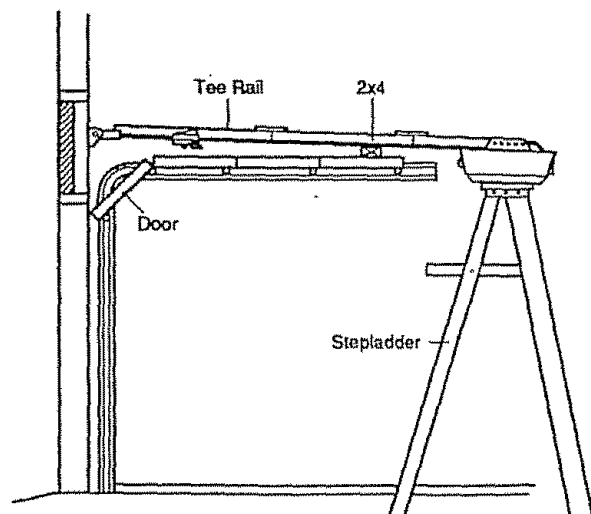

INSTALLATION ONE-PIECE DOOR WITH NO TRACK

PROCEDURE: Measure the distance from floor to top of door (in fully open position and parallel to the floor).

Using a stepladder as a support, raise opener chassis to the same distance from the floor (chassis will have a slight angle as shown).

The top of the door should be level with the top of opener. For maximum efficiency, do not position opener chassis more than 2 inches above this point.

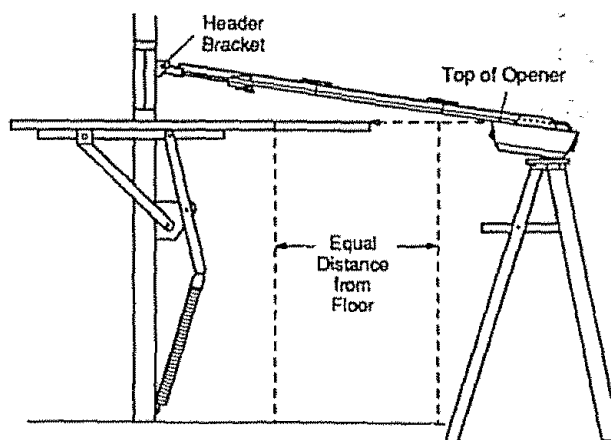

Installation

STEP 4 Hang Opener Chassis

THE OPENER CHASSIS MUST BE SECURELY FASTENED TO A STRUCTURAL SUPPORT OF GARAGE.

Three representative installations are shown. Yours may be different. Hanging brackets should be angled (Fig.1) or crossed (Fig.2) to provide rigid support. On finished ceilings (Fig.3), attach a sturdy metal bracket (not supplied) to ceiling joists before installing opener.

PROCEDURE: On EACH side of the opener measure the distance from chassis to the structural supports.

Cut both pieces of the hanging bracket to required lengths. Flatten one end of each bracket and bend or twist to fit the fastening angles. Do not bend at the bracket holes. Drill $3/16"$ pilot holes in the structural supports. Attach flattened ends of brackets to supports with $5/16" \times 1-7/8"$ lag screws.

Lift opener and fasten to hanging bracket as shown. Check to make sure Tee rail is centered over door. REMOVE 2×4 . Operate door manually. If door hits the rail, raise header bracket.

Grease the top and underside of rail surface on which trolley slides. A tube of grease is supplied.

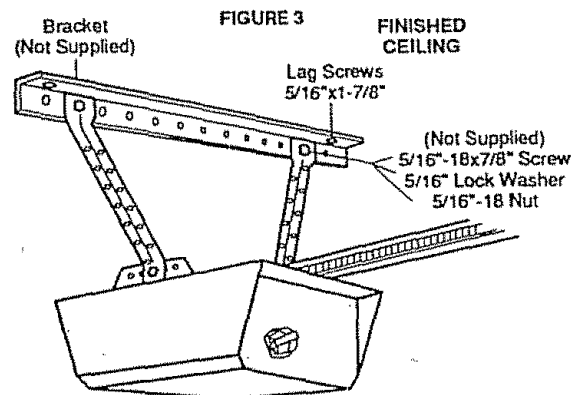
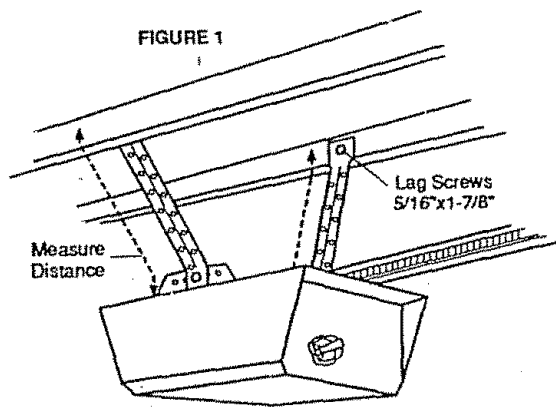
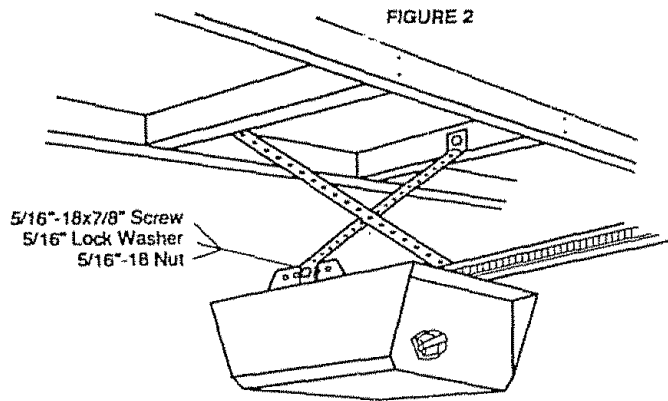

STEP 5 Attach Emergency Release Rope & Handle



USE EMERGENCY RELEASE ROPE ONLY TO DISENGAGE TROLLEY. DO NOT USE ROPE AND HANDLE TO PULL THE DOOR OPEN OR CLOSED.

PROCEDURE: Thread one end of rope through hole in top of red handle so 'NOTICE' reads right side up as shown. Secure with an overhand knot.

NOTE: Knot should be at least 1" from end of the rope to prevent slipping.

Thread other end of rope through hole in release arm of outer trolley. Adjust rope length so that handle is 6 feet above the floor. Secure with an overhand knot as above.

NOTE: If it is necessary to cut rope, heat seal cut end with a match or lighter to prevent fraying and/or raveling.

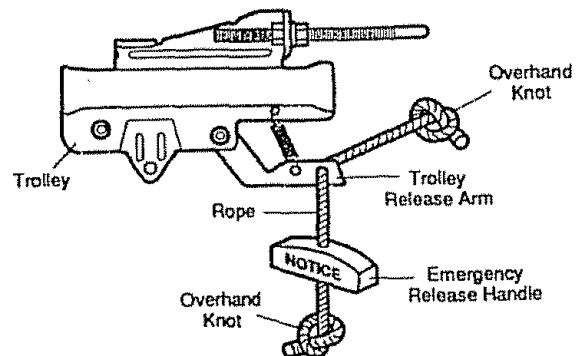

Installation

STEP 6 Install Wall Push Button



LOCATE WALL PUSH BUTTON (OR ANY ADDITIONAL PUSH BUTTONS) WHERE THE GARAGE DOOR IS VISIBLE, AWAY FROM DOOR AND DOOR HARDWARE AND OUT OF THE REACH OF CHILDREN. SERIOUS PERSONAL INJURY FROM A MOVING GARAGE DOOR MAY RESULT FROM MISUSE OF THE OPENER. DO NOT ALLOW CHILDREN TO OPERATE WALL PUSH BUTTON(S) OR THE TRANSMITTER. FASTEN THE CAUTION LABEL ON THE WALL NEAR WALL PUSH BUTTON AS A REMINDER OF SAFE OPERATING PROCEDURES.

PROCEDURE: Remove about a 1/4" of insulation from each end of the 2-strand bell wire. Connect one end to the screw terminals on the back of wall push button (or doorbell-type push button) as shown.

Fasten the wall push button with 6ABx1" sheet metal screws. The doorbell-type push button has 6ABx1-1/2" sheet metal screws. Use anchors if attaching to dry wall. Install on an inside garage door. A convenient place is beside the service door and **OUT OF REACH OF CHILDREN**.

Run the bell wire up the wall and across the ceiling to the garage door opener. Secure with insulated staples.

The receiver terminals and the antenna are located on the back panel of the opener chassis. Position antenna wire as shown. Then connect the wire by color to the white and red opener terminal screws.

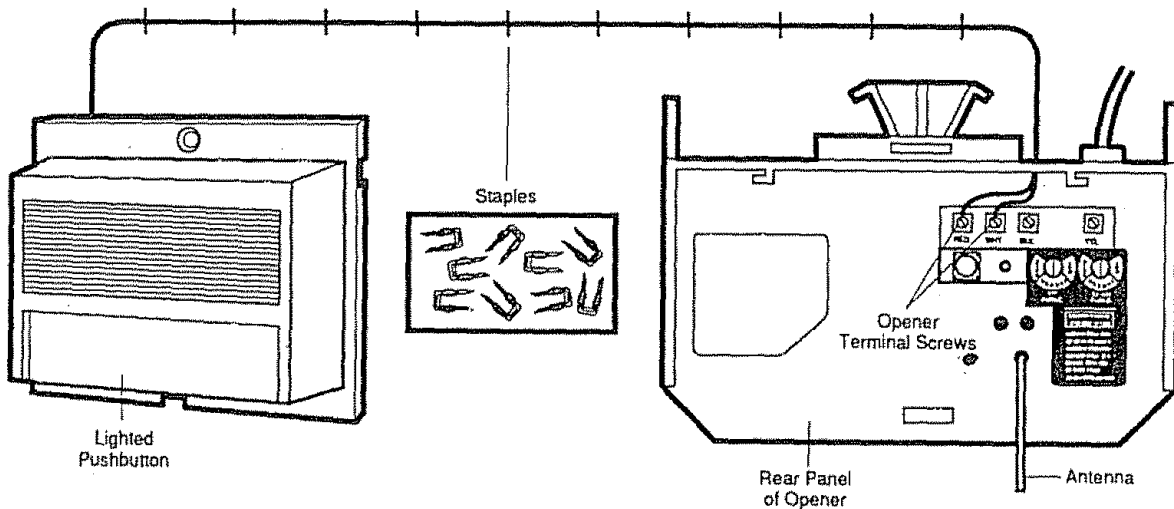
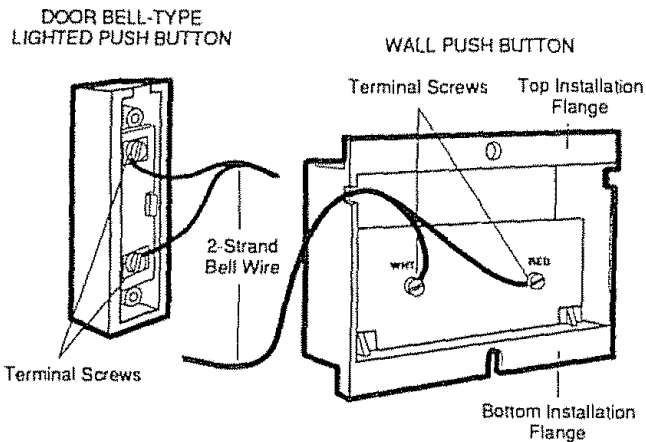

OPERATION OF THE WALL PUSH BUTTON

Press and release to open or close door.

Press and release again to REVERSE door during CLOSING cycle or to STOP door during OPENING cycle.

WIRING INSTRUCTIONS FOR ACCESSORIES

Infrared Reversing Sensor:
To white and black opener terminals

Outdoor Key Switch:
To red and white opener terminals

Installation

STEP 7 Install Light and Lens

INSTALLING LIGHT:

Install a 75 watt maximum light bulb in socket as shown. The light will turn on and remain lit for 4-1/2 minutes when power is connected. After 4-1/2 minutes it will turn off.

If light bulb burns out prematurely due to vibration, replace with a bulb specifically packaged for "Garage Door Openers".

INSTALLING LENS:

Slide the lens into the guides as shown. Snap the bottom tabs into lens slots.

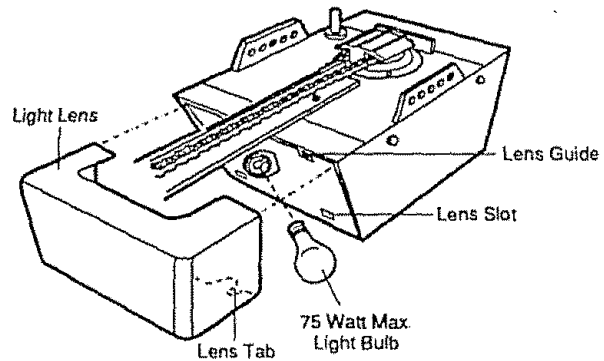

STEP 8 Connect Electric Power



TO AVOID SERIOUS PERSONAL INJURY FROM ENTANGLEMENT, REMOVE ALL ROPES CONNECTED TO THE GARAGE DOOR BEFORE OPERATING OPENER.

TO AVOID DAMAGE TO GARAGE DOOR AND OPENER, MAKE DOOR LOCKS INOPERATIVE BEFORE CONNECTING ELECTRIC POWER. USE A WOOD SCREW OR NAIL TO HOLD THE LOCKS IN "OPEN" (UNLOCKED) POSITION.

INSTALLATION & WIRING MUST BE IN COMPLIANCE WITH LOCAL ELECTRICAL AND BUILDING CODES. OPERATION AT OTHER THAN 120V 60Hz WILL CAUSE OPENER MALFUNCTION AND DAMAGE.

Opener **MUST** be permanently wired or plugged into a grounded 3-prong receptacle wired according to local electrical codes. **DO NOT** use a 2-wire adapter. **DO NOT** use an extension cord.

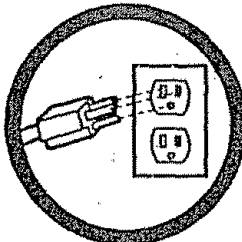

RIGHT

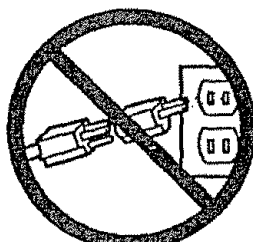

WRONG

IF LOCAL CODES REQUIRE PERMANENT WIRING:



DISCONNECT THE POWER AT THE FUSE BOX BEFORE PROCEEDING.

PROCEDURE: Refer to illustration. Make connection through the 7/8" diameter hole in top of opener chassis.

1. Remove opener chassis cover by removing the cover screws.
2. Remove attached 3-prong cord.
3. Connect the black (line) wire to black wire on terminal block; white (neutral) wire to the white terminal wire; the green (ground) wire to green ground screw.

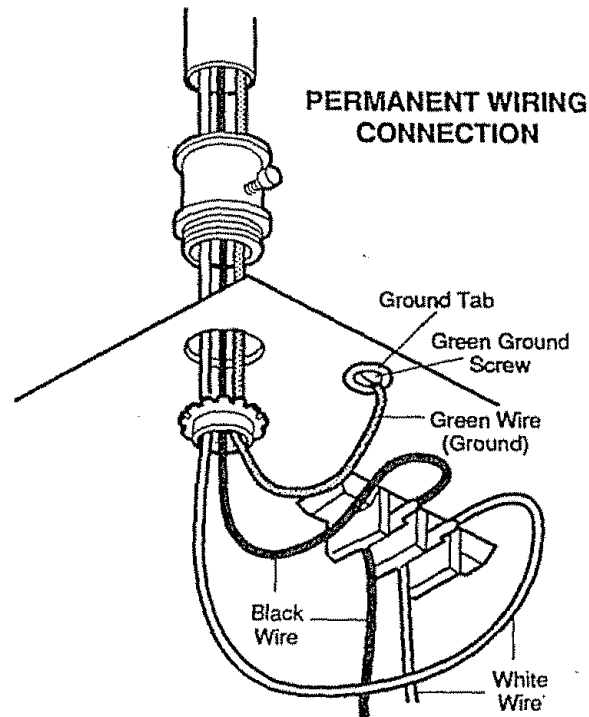

CAUTION: BE SURE THAT THE UNIT IS GROUNDED ACCORDING TO LOCAL CODE.

IMPORTANT NOTE: TO AVOID INSTALLATION DIFFICULTIES, DO NOT RUN OPENER NOW.

Installation

STEP 9 Install Door Bracket and Plate

Follow instructions which apply to your door type as illustrated below.



TO PREVENT DAMAGE TO LIGHTWEIGHT AND METAL GARAGE DOORS (OR ONES WITH GLASS PANELS), ALWAYS REINFORCE THE INSIDE OF DOOR—BOTH VERTICALLY AND HORIZONTALLY—WITH 2x4 BOARDS OR ANGLE IRON.

The horizontal brace should be at least 6 feet long. The vertical brace should cover height of top panel. Check with your garage door manufacturer for a door reinforcement kit for an opener installation.

Sectional Door Installation Procedure

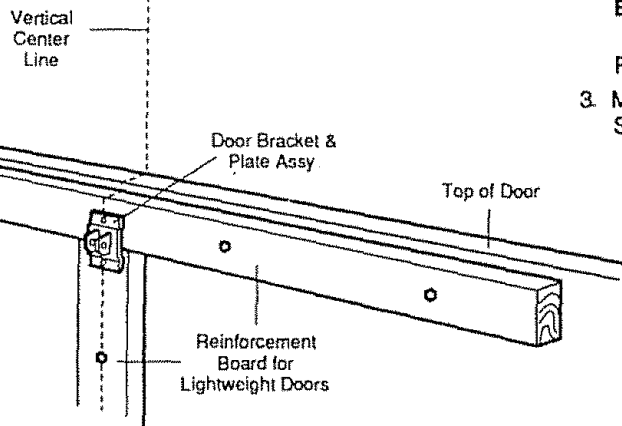
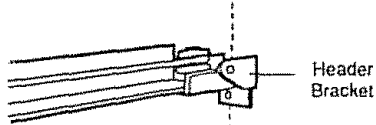

1. Assemble door bracket and plate as shown. Center bracket on previously marked vertical guideline.
2. Position the bracket assembly on the face of the door within the following limits:
 - A) The top edge of the bracket 2" - 4" below the top edge of the door.
 - B) Directly below any structural support across the top of the door.
 Placement depends on your particular needs.
3. Mark and drill 5/16" TOP and BOTTOM fastening holes. Secure bracket as shown.

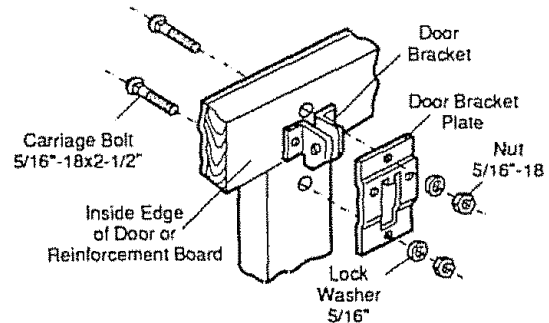

One-Piece Door Installation Procedure

NOTE: Door bracket has left and right side fastening holes. Assemble and install the door bracket and plate if your installation requires top and bottom fastening holes.

1. Center bracket (with or without plate as required) on top edge of door as shown. Mark holes.
2. Drill two 5/16" holes and fasten the door bracket with hardware supplied.

NOTE: If the door has no exposed framing, drill 3/16" pilot holes and use 5/16" x 1-1/2" lag screws (not supplied) to fasten bracket to top of door.

NOTE: The door bracket may be installed on face of door if required for your installation. (Refer to dotted line drawing.) **HOWEVER**, drill 3/16" pilot holes and substitute 5/16" x 1-1/2" lag screws (not supplied) to fasten the bracket to the door.

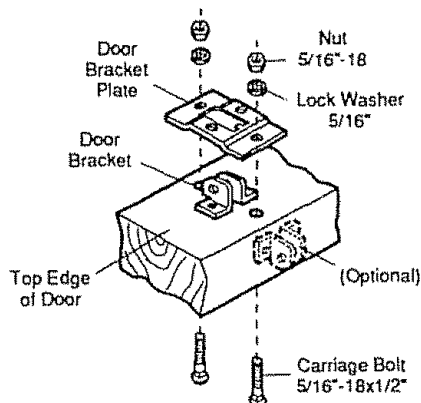

ONE PIECE DOOR

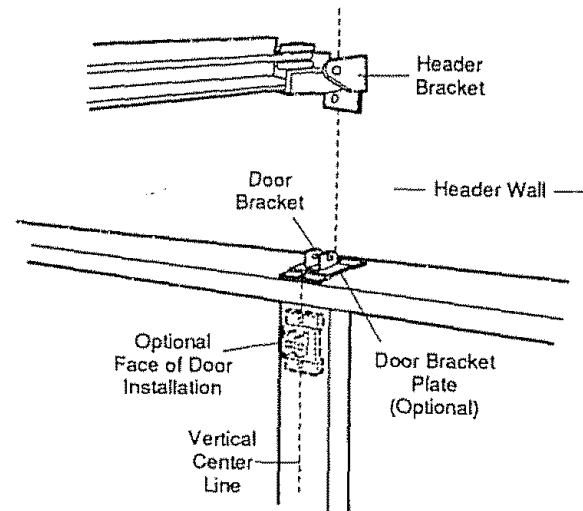

Installation

STEP 10 Connect Door Arm to Trolley

Follow only those instructions which apply to your door type.

SECTIONAL DOOR INSTALLATION

Make sure garage door is closed tight. Pull the emergency release handle to disconnect the trolley. Manually move outer trolley back to the center of inner trolley as shown in Figures A, B and C.

FIG A: Fasten straight door arm section to outer trolley with a clevis pin. Secure the connection with a ring fastener.

Fasten curved section to door bracket in the same way.

FIG B: Bring arm sections together. Find two pairs of holes that line up and join sections.

Select holes as far apart as possible to increase door arm rigidity.

FIG C: If holes in curved arm are ABOVE holes in straight arm, disconnect straight arm. Cut about 6" from the solid end. Reconnect to trolley with CUT END DOWN as shown.

Bring arm sections together. Find two pairs of holes that line up and join with screws, lock washers and nuts.

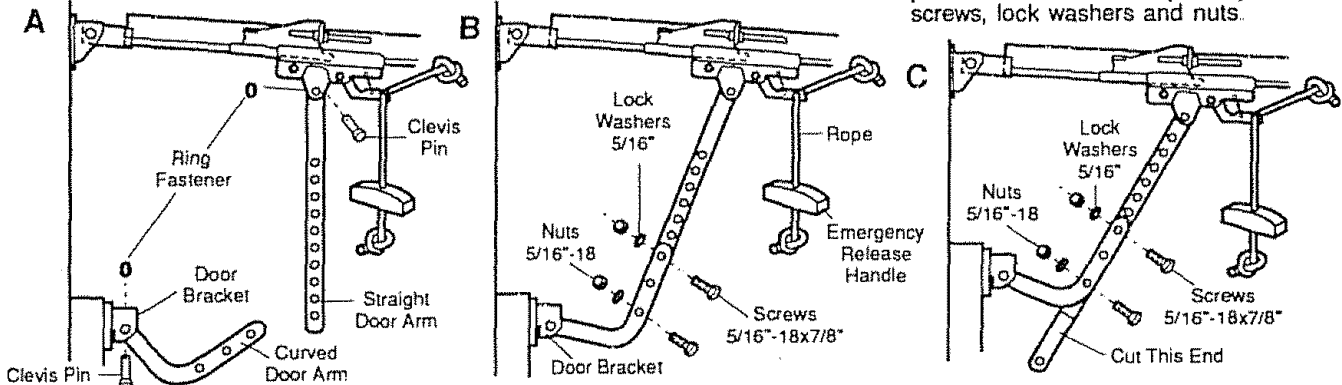

Proceed to Step 1, page 17. Trolley will re-engage automatically when opener is operated.

ONE-PIECE DOOR INSTALLATION

ASSEMBLE DOOR ARM: Fasten straight and curved door arm sections together to longest possible length. With door closed, connect straight door arm section to door bracket with a clevis pin. Secure with a ring fastener.

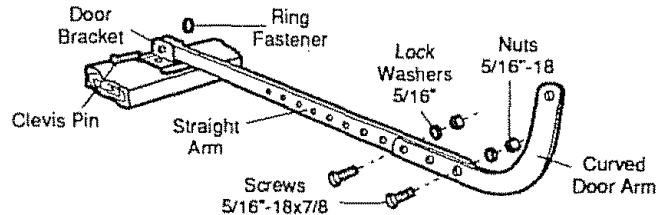

Before connecting door arm to trolley, limits of travel must be adjusted on one-piece doors. Limit adjustment screws are located on left side panel as shown in illustration on Page 17. Follow procedures below.

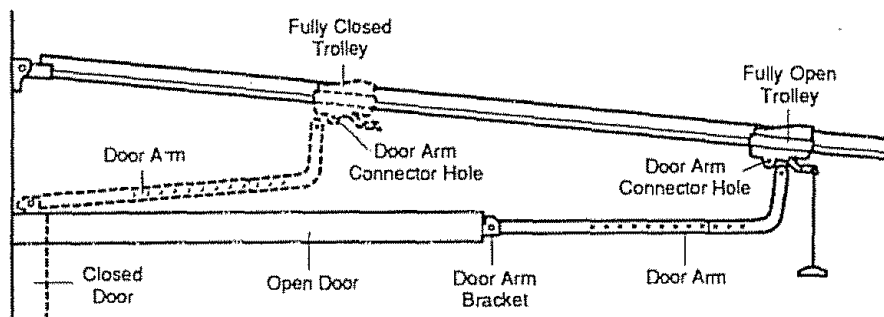

ADJUSTMENT PROCEDURES

OPEN DOOR ADJUSTMENT

Decrease UP limit. Turn UP limit adjustment screw counterclockwise 4 complete turns.

Press Lighted Wall Push Button. Trolley will travel to full open. Manually raise door arm to open position (parallel to floor) and lift door arm to trolley. The arm should touch trolley just in back of door arm connector hole as shown in solid line drawing. If arm does not extend far enough, adjust limit further. One full turn equals 2" of door travel.

CONNECT DOOR ARM TO TROLLEY: With door closed, join curved arm to connector hole in trolley with remaining clevis pin. Secure with ring fastening pin. NOTE: It may be necessary to lift door slightly to make connection.

Run opener through a complete travel cycle. If door has a slight 'downward' slant in full open position, decrease UP limits until door is parallel to floor.

CLOSED DOOR ADJUSTMENT

Decrease DOWN limit. Turn DOWN limit adjustment screw clockwise 8 complete turns.

Press Lighted Wall Push Button. Trolley will travel to full closed. Manually close door and lift door arm to trolley. The arm should touch trolley just ahead of door arm connector hole as shown in dotted line drawing. If arm is behind the connector hole, adjust limit further. One full turn equals 2" of door travel.

Adjustment

STEP 1 Adjust UP and DOWN Limits

LIMIT ADJUSTMENT settings regulate the points at which the door will stop when moving up or down.

NOTE: Door **STOPS** in the UP direction if anything interferes with door travel. Door **REVERSES** in the DOWN direction if anything interferes with the door travel (including binding or unbalanced doors).

PROCEDURE: To operate opener, press wall push button or transmitter. Run the opener through a **COMPLETE TRAVEL CYCLE**. Limit adjustments are not necessary when the door opens and closes completely and doesn't reverse unintentionally in the down position.

The following chart outlines adjustment procedures. Run the opener through a **COMPLETE TRAVEL CYCLE AFTER EACH ADJUSTMENT**. **NOTE: REPEATED OPERATION OF THE OPENER DURING ADJUSTMENT PROCEDURES MAY CAUSE MOTOR TO OVERHEAT AND SHUT OFF. SIMPLY WAIT 15 MINUTES AND TRY AGAIN.** Read chart carefully before proceeding to Step 2. Use a screwdriver to make limit adjustments.

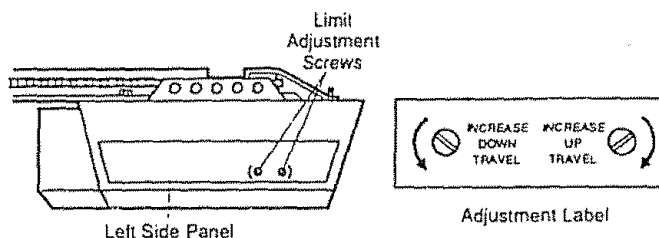

LIMIT ADJUSTMENT CHART

IF DOOR DOES NOT OPEN COMPLETELY BUT OPENS AT LEAST FIVE FEET

Increase UP travel. Turn the UP LIMIT adjustment screw clockwise. One turn equals 2" of travel.

If door does not open at least 5 feet: adjust OPEN FORCE as explained in Step 2.

IF DOOR DOES NOT CLOSE COMPLETELY (ON SECTIONAL DOORS)

Increase DOWN travel. Turn down limit adjustment screw counterclockwise. One turn equals 2" of travel.

If the door still will not close completely, the header bracket is positioned too high. Repeat Step 1, page 10.

IF DOOR DOES NOT CLOSE COMPLETELY (ON ONE-PIECE DOORS)

Increase DOWN travel. Turn the down limit adjustment screw counterclockwise. One turn equals 2" of travel.

IF DOOR REVERSES WHEN CLOSING AND THERE IS NO INTERFERENCE TO TRAVEL CYCLE

Test door for binding: Pull emergency release handle. Manually open and close door. If door is binding, call a door serviceman. If door is not binding or unbalanced, adjust CLOSE FORCE. See Step 2.

IF OPENER REVERSES IN FULLY CLOSED POSITION

Decrease DOWN travel. Turn down limit adjustment screw clockwise. One turn equals 2" of travel.

STEP 2 Adjust Force



DO NOT USE FORCE ADJUSTMENTS TO COMPENSATE FOR A BINDING OR STICKING GARAGE DOOR. EXCESSIVE FORCE WILL INTERFERE WITH PROPER OPERATION OF SAFETY REVERSE SYSTEM OR DAMAGE GARAGE DOOR.

Force Adjustment Controls are located on rear panel of opener. FORCE ADJUSTMENT settings regulate amount of the power required to open and close door.

NOTE: The door **STOPS** in the UP direction if anything interferes with its travel. Door **REVERSES** in the DOWN direction if anything interferes with its travel (including binding or unbalanced doors).

If the force adjustments are set too light, door travel may be interrupted by nuisance reversals in DOWN direction and stops in UP direction. As weather conditions can affect the door movement, occasional adjustment may be needed.

Maximum force adjustment range is 260 degrees, about 3/4 of a complete turn. Do not force controls beyond that point. Turn force adjustment controls with a screwdriver.

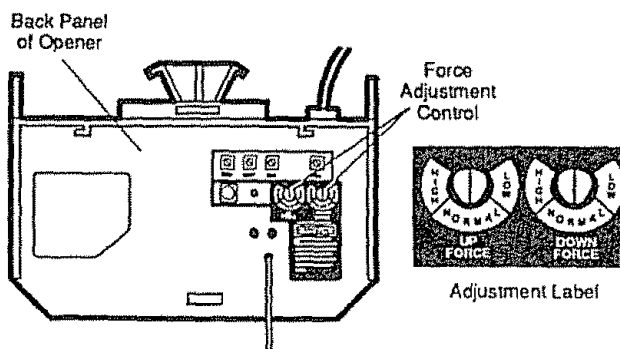

FORCE ADJUSTMENT CHART

TEST DOWN (CLOSE) FORCE

Grasp the door handle or door bottom when door is about halfway through DOWN (CLOSE) TRAVEL. Door should reverse. If the door is hard to hold or doesn't reverse, decrease DOWN (CLOSE) FORCE by turning the control in a counterclockwise direction. Make 10 degree turn adjustments until door reverses normally. After each adjustment, run opener through a complete cycle.

PROCEED TO STEP 3

IF DOOR DOESN'T OPEN AT LEAST 5 FEET

Increase UP (OPEN) FORCE by turning control clockwise. Make 10 degree turn adjustments until door opens completely. Readjust UP LIMIT if necessary. After each adjustment, run opener through a complete travel cycle.

IF DOOR REVERSES DURING DOWN (CLOSE) CYCLE

Increase DOWN (CLOSE) FORCE by turning the control clockwise. Make 10 degree turn adjustments until door completes close cycle. After each adjustment, run the opener through a complete travel cycle.

Adjustment

STEP 3 Test Safety Reverse System



THE SAFETY REVERSE SYSTEM TEST IS IMPORTANT. GARAGE DOOR MUST REVERSE ON CONTACT WITH A ONE INCH OBSTACLE PLACED ON THE FLOOR. FAILURE TO PROPERLY ADJUST OPENER MAY RESULT IN SERIOUS PERSONAL INJURY FROM A CLOSING GARAGE DOOR. REPEAT TEST AT LEAST FOUR TIMES A YEAR AND ADJUST AS NEEDED.

PROCEDURE: Place a 1-inch obstacle on the floor under the garage door. Operate door in DOWN direction. The door MUST reverse on the obstruction.

If the door STOPS on the obstruction, it is not traveling far enough in the DOWN direction. Increase the DOWN limit by turning DOWN limit adjustment screw counter-clockwise 1/4 turn. REPEAT TEST.

NOTE: Make sure limit adjustments do not force the door arm beyond a straight up and down position. See the illustration on Page 16.

When the door reverses on the 1-inch obstacle, remove the obstruction and run the opener through a complete travel cycle. Door MUST NOT reverse in closed position. If it does, repeat Adjustment Steps 1, 2 and 3.

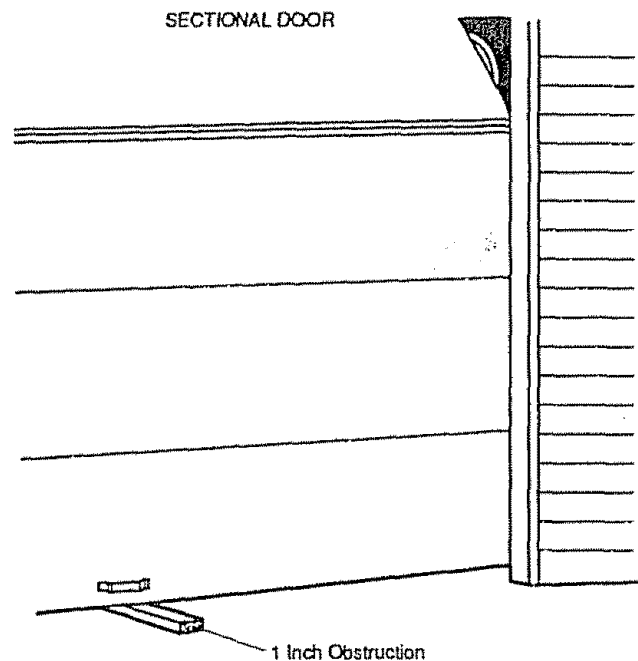
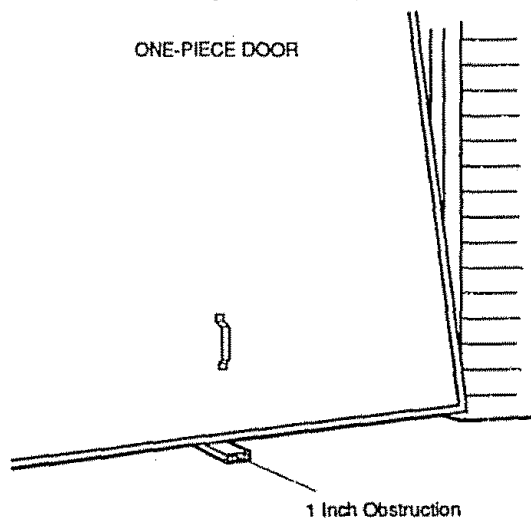

REPEAT ADJUSTMENT STEP 3 AFTER:



- EACH ADJUSTMENT OF DOOR ARM LENGTH, CLOSE FORCE OR DOWN LIMIT.
- ANY REPAIR OR ADJUSTMENT OF GARAGE DOOR (INCLUDING SPRINGS AND HARDWARE).
- ANY REPAIR OR BUCKLING OF THE GARAGE FLOOR.
- ANY REPAIR OR ADJUSTMENT OF THE GARAGE DOOR OPENER.

(Optional) STEP 4 Install Infrared Reversing Sensor

The INFRARED REVERSING SENSOR provides an ADDITIONAL measure of safety against a small child being caught under a garage door. It uses an invisible beam which, when broken by an obstruction, causes a closing door to open and prevents an open door from closing.

After the garage door opener has been completely installed and adjusted, the INFRARED REVERSING SENSOR accessory can be installed. Instructions are included with this optional device.

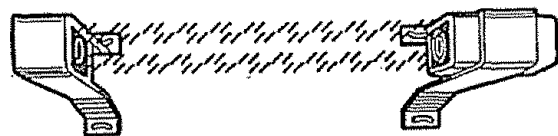

Radio Controls

F.C.C. rules prohibit adjustments to or modification of receiver and transmitter circuitry except for changing the code setting and replacing the transmitter battery. **THERE ARE NO OTHER USER SERVICEABLE PARTS.**

Manufactured under 1 or more of the following U.S. patents: RE29,525; 4,037,201; 4,750,118; 4,806,930

Your 53000SR SERIES garage door opener (with RECEIVER 'SR' CODE BUTTON) has been factory set to operate with the LARGE push button on the transmitter. The 3-function transmitter(s) can also activate additional garage door openers and/or light controls - 53000 and/or 53000SR SERIES.

Instructions are given below for matching the code in all transmitters, changing your code selection or using the transmitter(s) with other receivers.

MATCH/CHANGE THE CODE IN TRANSMITTER(S)

SET CODE SWITCHES IN ALL TRANSMITTERS TO MATCHING POSITIONS

1. Locate the code switches in transmitter(s), either by sliding battery compartment cover down or by removing cover screw and carefully turning case top over.
2. With a pen or a screwdriver, change the setting of one or more switch (to a (+), (-) or (0) position).

NOTE: Code switches 2 through 9 in ALL transmitters used to operate a receiver must be set to match. (Code switch 1 on a 3-function transmitter is neutral. Set it to ANY position. It will not affect the code selected).

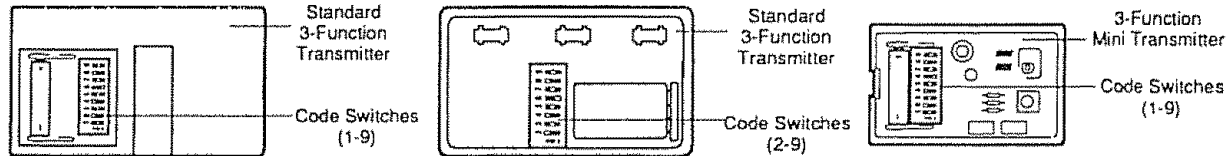

SET RECEIVER TO MATCH TRANSMITTER(S) CODE

53000SR SERIES (WITH RECEIVER CODE BUTTON)
Garage Door Openers and Light Controls
(Illustration A shows a garage door opener receiver)

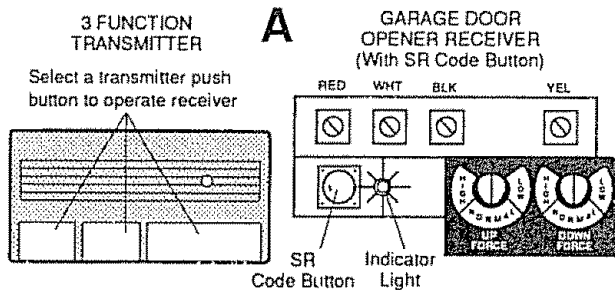

3. Press the RECEIVER SR code button on the right side panel of opener (Illustration A). The indicator light will turn ON.
4. **STAND AWAY FROM THE DOOR** and press the selected push button on the transmitter. The indicator light will turn OFF and door will move. Receiver and transmitter codes now match and the opener will operate with the selected push button on the transmitter.

NOTE: If transmitter push button is not pressed within 30 seconds, the indicator light will turn OFF. Begin again at Step 3.

TO USE THE TRANSMITTER(S) WITH OTHER 53000SR SERIES RECEIVERS: Select another transmitter push button to operate the Light Control or additional garage door opener. Make sure all transmitters used to operate receiver are set to the same code (Steps 1 and 2). Repeat Steps 3 and 4.

53000 SERIES (WITH RECEIVER CODE SWITCHES)
Garage Door Openers and Light Controls
(Illustration B shows a garage door opener receiver)

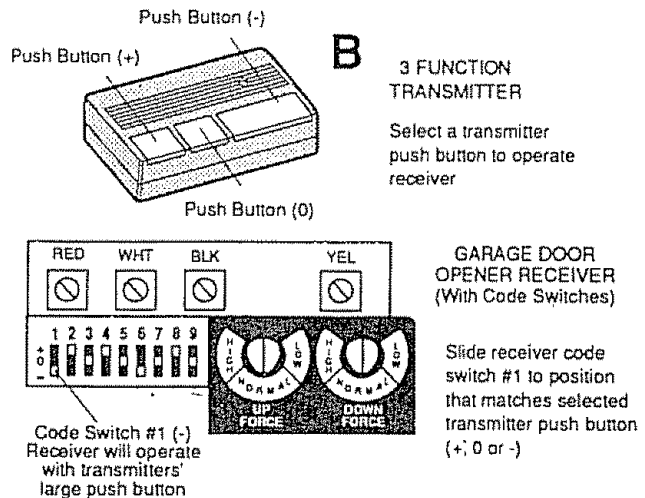

3. Locate the receiver code switches. Set code switch #1 to match transmitter push button you want to use with that receiver (+), (0) or (-). Refer to illustration (B).
4. Hold a transmitter (with code switches visible) alongside the receiver. Beginning with RECEIVER code switch #2, match the position of each transmitter switch.

TO USE THE TRANSMITTER(S) WITH OTHER 53000 SERIES RECEIVERS: Select another transmitter push button to operate the Light Control or additional garage door opener. Make sure all transmitters are set to a matching code (Steps 1 and 2). Repeat Steps 3 and 4.

Having a Problem?

Review Pages 2 and 3 Before Proceeding

SITUATION

PROBABLE CAUSE & SOLUTION

OPENER DOESN'T OPERATE FROM EITHER THE WALL PUSH BUTTON OR TRANSMITTER

1. Have you disengaged all door locks? Review Step 8, page 14.
2. Does the opener have electric power? Plug a lamp into the outlet. If it doesn't light, check fuse box or circuit breaker. (Some outlets are controlled by a wall switch.)
3. Repeated operation may have tripped the overload protector in the motor. Wait 15 minutes. Try again.
4. Is there a build-up of ice or snow under door? Door may be frozen to ground. Remove any obstruction.
5. Remove bell wire from opener terminals. Short red and white terminals by touching both terminals at same time with a piece of metal (screwdriver or coin). If opener runs, check for a faulty wire connection at wall push button or a short under staples.

OPENER OPERATES FROM TRANSMITTER BUT NOT FROM WALL PUSH BUTTON

1. Is wall push button lit? If not, refer to No. 5 above and follow same procedure.
2. Are wiring connections correct? Review Step 6, page 13.

DOOR OPERATES FROM WALL PUSH BUTTON BUT NOT FROM THE TRANSMITTER

1. Does the battery test light glow when transmitter push button is pressed? If not, replace the battery.
2. If you have two transmitters and only one operates, review the code setting procedures on page 19. ALL transmitters must be set to same code.
3. Is transmitter(s) operating any other remote control devices? See the code setting procedures on page 19.
4. Did you press the transmitter button designated to operate garage door opener?
5. Reprogram receiver and ALL transmitters. Try setting ALL transmitter code switches on plus, center or minus positions. If transmitter(s) works, you can try a random code switch setting again, if you desire.

TRANSMITTER HAS SHORT RANGE

1. Check battery test light. If the light is dim, change the battery.
2. Change the location of the transmitter in the car.
3. A metal garage door or foil-backed insulation or metal siding will reduce the transmission range. Antenna extender kit is available from any Sears Store or Service Center.
4. Check to be sure antenna on the back panel of opener extends fully downward.

THE GARAGE DOOR OPENS AND CLOSES BY ITSELF

1. Is there a neighbor with a garage door opener using the same frequency code? Change your code. Review page 19.
2. Check to be sure that none of the transmitter push buttons is stuck in the 'down' position.
3. Remove bell wire from opener terminals and operate from transmitter only. If this solves the problem, the wall push button is faulty (replace), or there is a short or broken wire between push button and opener.

DOOR DOESN'T OPEN COMPLETELY

1. Is something obstructing the door?
2. If door opens at least 5 feet, travel limits may need to be increased. One turn equals 2 inches of travel. See page 17.
REPEAT SAFETY REVERSE TEST after the adjustment is complete.
3. If door has been working properly but now doesn't open all the way, increase the UP FORCE. See page 17.
REPEAT SAFETY REVERSE TEST after the adjustment is complete.

DOOR DOESN'T CLOSE COMPLETELY

1. Is something obstructing the door?
2. Review the Travel Limits Adjustment Chart on page 17.
REPEAT SAFETY REVERSE TEST after any adjustment of door arm length, close force or down limit.

DOOR WON'T CLOSE

1. The Infrared Reversing Sensor (If you have installed this accessory) may be misaligned or obstructed. Disconnect sensor and check door operation. If problem disappears, correct alignment.

Having a Problem? (continued)

SITUATION	PROBABLE CAUSE & SOLUTION
DOOR REVERSES FOR NO APPARENT REASON	<ol style="list-style-type: none">1. Is something obstructing the door? Pull red emergency release handle. Operate door manually. If it is unbalanced or binding, call a garage door serviceman to correct the problem.2. Clear any ice or snow from garage floor area where garage door closes.3. Review the Force Adjustment Chart on page 17. REPEAT SAFETY REVERSE TEST after adjustment is complete.4. If door reverses in FULLY CLOSED position, decrease travel limits (see page 17). REPEAT SAFETY REVERSE TEST after the adjustment is complete. THE NEED FOR OCCASIONAL ADJUSTMENT OF THE FORCE AND LIMIT SETTINGS IS NORMAL. WEATHER CONDITIONS IN PARTICULAR CAN AFFECT DOOR TRAVEL.5. The Infrared Reversing Sensor (if you have installed this accessory) may be misaligned or obstructed. Disconnect sensor and check door operation. If problem disappears, correct alignment.
OPENER LIGHT	<p>DOESN'T TURN ON</p> <ol style="list-style-type: none">1. Replace the light bulb (75 watts maximum). Use a "garage door opener bulb" if standard bulb burns out prematurely due to vibration. Vibration may be caused by loose end panel. Retighten screws. <p>DOESN'T TURN OFF</p> <ol style="list-style-type: none">1. There may be a defective ground at ceiling or wall receptacle. UNIT MUST BE GROUNDED.
OPENER STRAINS OR MAXIMUM FORCE IS NEEDED TO OPERATE DOOR	<ol style="list-style-type: none">1. Door may be out of balance or springs are broken. Close door and use emergency release rope and handle to disconnect trolley. Open and close door manually. A properly balanced door will stay in any point of travel while being supported entirely by its springs. If it does not, call a garage door serviceman to correct the problem.
OPENER MOTOR HUMS BRIEFLY, THEN WON'T WORK	<ol style="list-style-type: none">1. Garage door springs are broken. SEE ABOVE2. The trolley may be jammed into stop bolts. Pull or push on door while motor is humming to release jammed condition. Re-adjust door limits (page 17) to prevent over-travel. REPEAT SAFETY REVERSE TEST after adjustment is complete.3. If the problem occurs on first operation of the opener, door is locked. DISABLE DOOR LOCK. If chain was removed and reinstalled, motor may be out of phase. Remove chain; cycle motor to the down position. (Observe drive sprocket. When it turns in clockwise direction and stops in down position.) Reinstall chain. REPEAT SAFETY REVERSE TEST after adjustment is complete.
OPENER WON'T OPERATE DUE TO POWER FAILURE	<ol style="list-style-type: none">1. Use emergency release rope and handle to disconnect trolley. Door can be opened and closed manually. When the power is restored, press the wall push button and trolley will automatically reconnect. Refer to Page 3 for Lockout Feature2. The emergency release Key Lock accessory (for use on garages with no service door) disconnects the trolley from outside the garage in case of power failure.
CHAIN DROOPS OR SAGS	<ol style="list-style-type: none">1. It is normal for chain to droop slightly in the closed door position. Use emergency release rope and handle to disconnect trolley. If chain returns to normal height when the trolley is disengaged and door reverses on a one-inch obstruction, no adjustments are needed (see page 9).
OPENER NOISE IS DISTURBING IN LIVING QUARTERS OF HOME	<ol style="list-style-type: none">1. If operational noise is a problem because of proximity of the opener to the living quarters, Vibration Isolator Kit 41A3263 can be ordered from any Sears Service Center and most Sears stores. This kit was designed to eliminate the 'sounding board effect' and is easy to install.

Repair Parts

RAIL ASSEMBLY PARTS LIST

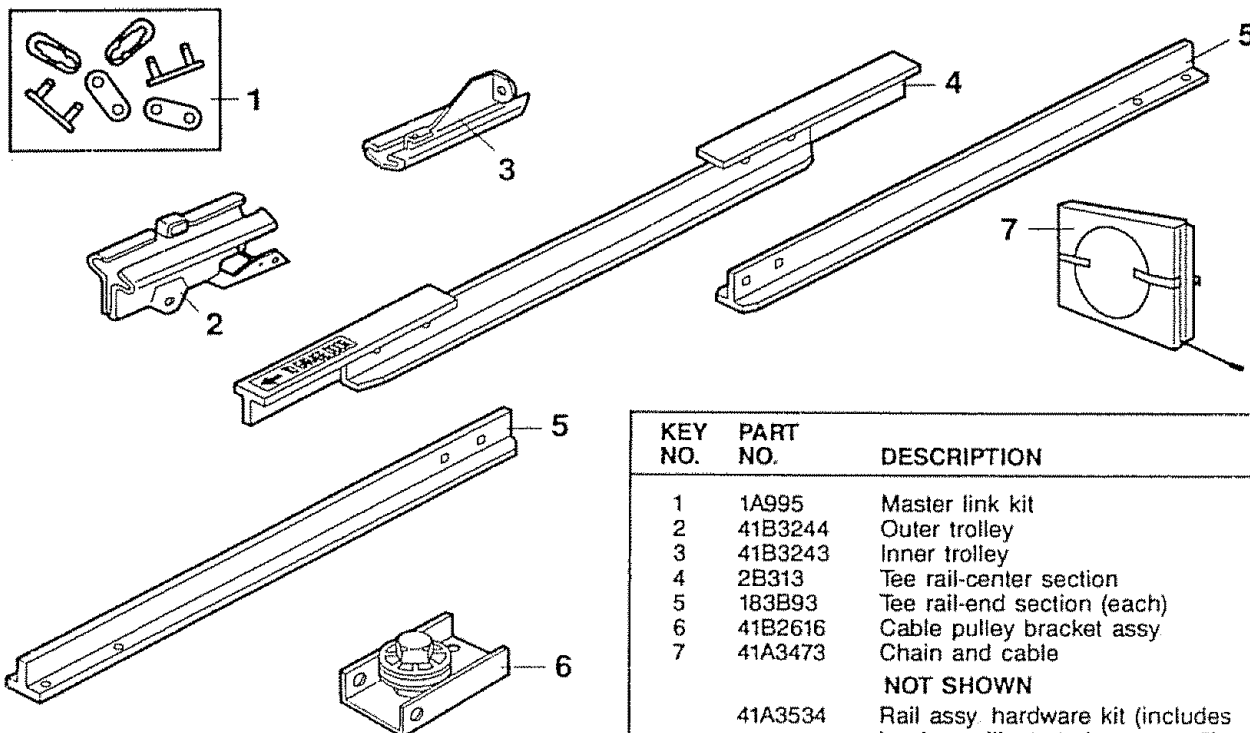

KEY NO.	PART NO.	DESCRIPTION
1	1A995	Master link kit
2	41B3244	Outer trolley
3	41B3243	Inner trolley
4	2B313	Tee rail-center section
5	183B93	Tee rail-end section (each)
6	41B2616	Cable pulley bracket assy
7	41A3473	Chain and cable
	NOT SHOWN	
	41A3534	Rail assy hardware kit (includes hardware illustrated on page 5)

INSTALLATION PARTS LIST

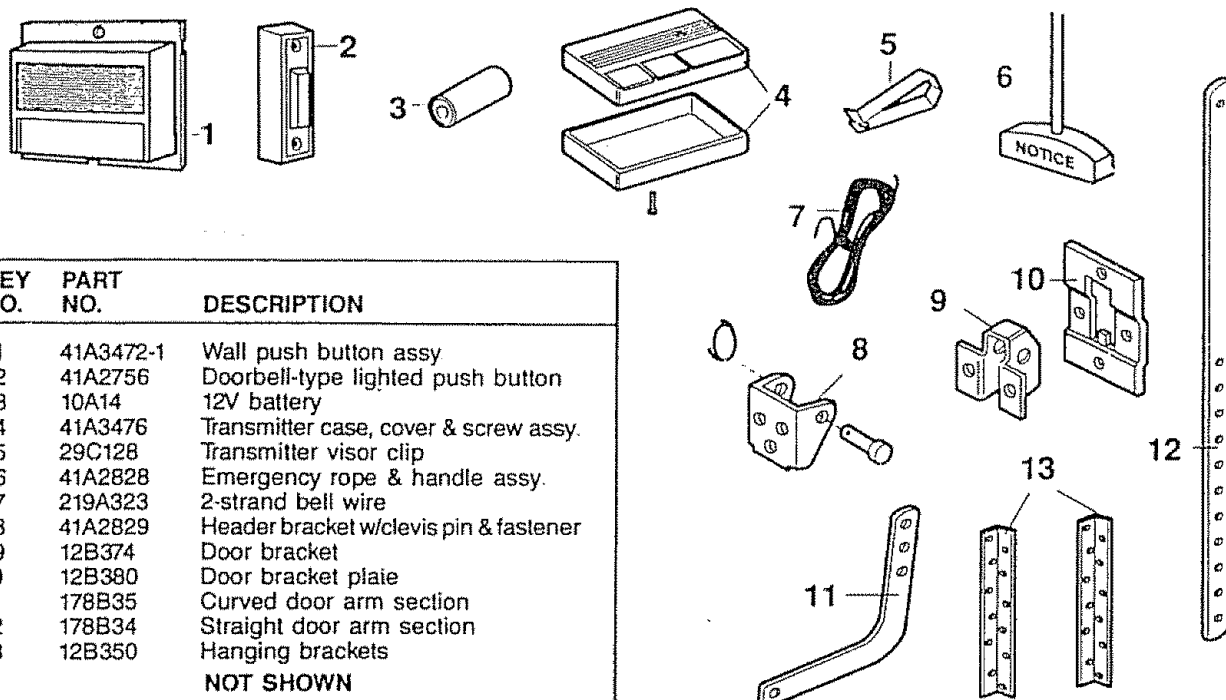

KEY NO.	PART NO.	DESCRIPTION
1	41A3472-1	Wall push button assy
2	41A2756	Doorbell-type lighted push button
3	10A14	12V battery
4	41A3476	Transmitter case, cover & screw assy.
5	29C128	Transmitter visor clip
6	41A2828	Emergency rope & handle assy.
7	219A323	2-strand bell wire
8	41A2829	Header bracket w/clevis pin & fastener
9	12B374	Door bracket
10	12B380	Door bracket plate
11	178B35	Curved door arm section
12	178B34	Straight door arm section
13	12B350	Hanging brackets
	NOT SHOWN	
	41A3535	Installation hardware bag (includes hardware illustrated on page 5)
	41A1139	Owners manual

114A1277

Free Manuals Download Website

<http://myh66.com>

<http://usermanuals.us>

<http://www.somanuals.com>

<http://www.4manuals.cc>

<http://www.manual-lib.com>

<http://www.404manual.com>

<http://www.luxmanual.com>

<http://aubethermostatmanual.com>

Golf course search by state

<http://golfingnear.com>

Email search by domain

<http://emailbydomain.com>

Auto manuals search

<http://auto.somanuals.com>

TV manuals search

<http://tv.somanuals.com>