

**Owner's Manual**

# **CRAFTSMAN**

**19" Mulching/Rear Discharge  
PUSH LAWN MOWER**

Model No.  
**247.388240**

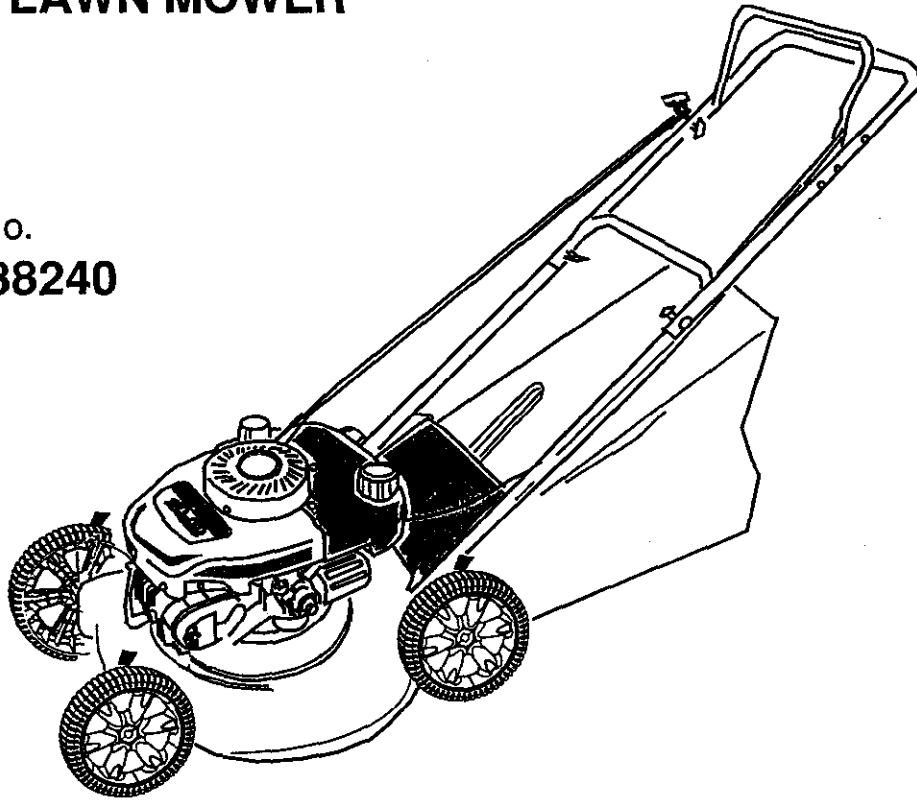

**CAUTION:** Before using this product,  
read this manual and follow all Safety  
Rules and Operating Instructions.

**Sears, Roebuck & Co., Hoffman Estates, IL 60179, U.S.A.**

Printed in U.S.A.

770-10185A  
(1/99)

# TABLE OF CONTENTS

Content	Page	Content	Page
Warranty Information .....	2	Service & Adjustment.....	15
Safe Operation Practices .....	3	Storage .....	17
Slope Gauge .....	6	Trouble-Shooting .....	19
Assembly .....	7	Parts List.....	20
Operation.....	9	Espanól.....	26
Maintenance .....	12		

## WARRANTY INFORMATION

### Two-Year Warranty on Craftsman Lawn Mower

For two years from the date of purchase, when this Craftsman lawn mower is maintained, lubricated, and tuned up according to the instructions in the owner's manual, Sears will repair, free of charge, any defects in material or workmanship. If this lawn mower is used for commercial or rental purposes, this warranty applies for only 90 days from the date of purchase.

This warranty does not cover:

1. Expendable items which become worn during normal use, such as rotary mower blades, blade adapters, belts, air cleaners and spark plug.
2. Repairs necessary because of operator abuse or negligence, including bent crankshafts and the failure to maintain equipment according to the instructions contained in the owner's manual.

**WARRANTY SERVICE IS AVAILABLE BY RETURNING THE CRAFTSMAN LAWN MOWER TO THE NEAREST SEARS SERVICE CENTER IN THE UNITED STATES. THIS WARRANTY APPLIES ONLY WHILE THIS PRODUCT IS IN USE IN THE UNITED STATES.**

This warranty gives you specific legal rights, and you may also have other rights which vary from state to state.  
Sears, Roebuck And Co., D/817WA, Hoffman Estates, IL 60179

## ACCESSORIES

These accessories were available when the lawn mower was purchased. They are also available at most Sears retail outlets, and service centers. Most Sears stores can order repair parts for you when you provide the model number of your lawn mower.

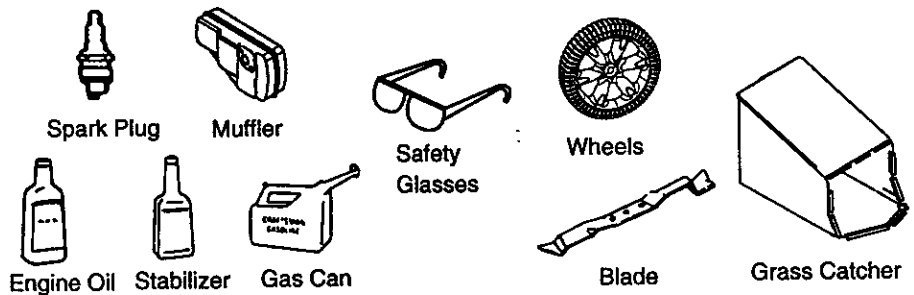

PRODUCT SPECIFICATIONS	
Horsepower:	4.0
Engine Oil	21 oz. SAE 30 oil
Fuel Capacity:	1.5 quarts
Spark Plug	J19LM Gap .030 inches

Please record model number, serial number, and date of purchase here for future reference. You will find this information on the model plate located on the cutting deck of your mower.	
Model Number .....	.....
Serial Number.....	.....
Date of Purchase .....	.....

# SAFE OPERATION PRACTICES



This symbol points out important safety instructions which, if not followed, could endanger the personal safety and/or property of yourself and others. Read and follow all instructions in this manual before attempting to operate your lawn mower. Failure to comply with these instructions may result in personal injury. When you see this symbol—heed its warning.



**DANGER:**

Your lawn mower was built to be operated according to the rules for safe operation in this manual. As with any type of power equipment, carelessness or error on the part of the operator can result in serious injury. If you violate any of these rules, you may cause serious injury to yourself or others.



This unit is equipped with an internal combustion engine and should not be used on or near any unimproved forest-covered, brush-covered or grass-covered land unless the engine's exhaust system is equipped with a spark arrester meeting applicable local or state laws (if any). If a spark arrester is used, it should be maintained in effective working order by the operator.

In the State of California the above is required by law (Section 4442 of the California Public Resources Code). Other states may have similar laws. Federal laws apply on federal lands. A spark arrester for the muffler is available through your nearest Sears Authorized Service Center (See the REPAIR PARTS section of this manual.)



**WARNING:** The engine exhaust from this product contains chemicals known to the State of California to cause cancer, birth defects or other reproductive harm.

## GENERAL OPERATION

- Read this owner's guide carefully in its entirety before attempting to assemble this machine. Read, understand, and follow all instructions on the machine and in the manual(s) before operation. Be completely familiar with the controls and the proper use of this machine before operating it. Keep this manual in a safe place for future and regular reference, and for ordering replacement parts.
- Your rotary mower is a precision piece of power equipment, not a plaything. Therefore, exercise extreme caution at all times. Your unit has been designed to perform one job: to mow grass. Do not use it for any other purpose.
- Never allow children under 14 years old to operate a power mower. Children 14 years old and over should only operate mower under close parental supervision. Only responsible individuals who are familiar with these rules of safe operation should be allowed to use your mower.
- Keep the area of operation clear of all persons, particularly small children and pets. Stop engine when they are in the vicinity of your mower to help prevent blade contact or thrown object injury. Although the area of operation should be completely cleared of foreign objects, an object may have been overlooked and could be accidentally thrown by the mower in any direction and cause serious personal injury to the operator or any others allowed in the area.
- Thoroughly inspect the area where the equipment is to be used. Remove all stones, sticks, wire, bones, toys and other foreign objects which could be picked up and thrown by the mower in any direction and cause serious personal injury to the operator or any others allowed in the area. Plan your mowing pattern to avoid discharge of material toward roads, sidewalks, bystanders and the like. To help avoid a thrown object's injury, keep children, bystanders and helpers at least 75 feet from the mower while it is in operation.
- Always wear safety glasses or safety goggles during operation or while performing an adjustment or repair, to protect eyes from foreign objects that may be thrown from the machine in any direction.
- Wear sturdy, rough-soled work shoes and close-fitting slacks and shirts. Shirts and pants that cover the arms and legs and steel-toed shoes are recommended. Do not wear loose fitting clothes or jewelry. They can be caught in moving parts. Never operate a unit in bare feet, sandals, slippery or light weight (e.g. canvas) shoes.
- Do not put hands or feet near or under rotating parts. Keep clear of discharge opening at all times as the rotating blade can cause injury.
- Many injuries occur as a result of the mower being pulled over the foot during a fall. Do not hang on to the mower if you are falling; release the handle immediately.
- Never pull the mower toward you while you are walking. If you must back the mower away from a

wall or obstruction first look down and behind, and then follow these steps:

- a. Step back from the mower to fully extend your arms.
  - b. Be sure you are well balanced with sure footing.
  - c. Pull the mower back slowly, no more than half way toward you.
  - d. Repeat these steps as needed.
- Do not operate the mower while under the influence of alcohol or drugs.
  - Do not engage the self-propelled mechanism on units so equipped while starting engine.
  - The blade control handle is a safety device. Never attempt to bypass its operation. Doing so makes the safety device inoperative and may result in personal injury through contact with the rotating blade. The blade control handle must operate easily in both directions and automatically return to the disengaged position when released.
  - Never operate the mower in wet grass. Always be sure of your footing. A slip and fall can cause serious personal injury. Keep a firm hold on the handle and walk, never run. If you feel you are losing your footing, **RELEASE THE BLADE CONTROL HANDLE IMMEDIATELY** and the blade will stop rotating within three seconds.
  - Mow only in daylight or good artificial light.
  - Stop the blade when crossing gravel drives, walks or roads.
  - If the equipment should start to vibrate abnormally, stop the engine and check immediately for the cause. Vibration is generally a warning of trouble.
  - Shut the engine off and wait until the blade comes to a complete stop before removing the grass catcher or unclogging the chute. The cutting blade continues to rotate for a few seconds after the engine is shut off. Never place any part of the body in the blade area until you are sure the blade has stopped rotating.
  - Never operate mower without proper guards, grass catcher, plates or other safety protective devices in place.
  - Muffler and engine become hot and can cause a burn. Do not touch.
  - Do not adjust the throttle control with the engine running.
  - Only use accessories approved for this machine by the manufacturer. Read, understand, and follow all instructions provided with the approved accessory.
  - If situations occur which are not covered in this manual, use care and good judgment. Contact your dealer for assistance.

## Slope Operation

For your safety, use the slope gauge included as part of this manual to measure slopes before operating this unit on a slope or hilly area. If the slope is greater than 15 degrees

as shown on the slope gauge (page 6), do not operate this unit on that area or serious injury could result.

### DO:

- Mow across the face of slopes; never up and down. Exercise extreme caution when changing direction on slopes.
- Watch for holes, ruts, hidden objects, or bumps. Tall grass can hide obstacles.
- Always be sure of your footing. A slip and fall can cause serious personal injury. If you feel you are losing your balance release the blade control handle immediately and the blade will stop in less than 3 seconds.
- **ON MODELS WITH CASTER WHEELS:** Lock both front wheels so they do not pivot while mowing on the face of slopes. To turn the mower, depress the handle and raise the front wheels slightly.

### DO NOT:

- Do not mow near drop-offs, ditches or embankments. The operator could lose footing or balance.
- Do not mow slopes greater than 15 degrees as shown on the slope gauge.
- Do not mow on wet grass. Reduced footing could cause slipping.
- **ON MOWERS WITH CASTER WHEELS:** Do Not mow on slopes with casters unlocked since the mower has a tendency to drift down hill.

## Children

Tragic accidents can occur if the operator is not alert to the presence of children. Children are often attracted to the mower and the mowing activity. Never assume that children will remain where you last saw them.

- Keep children out of the mowing area and under the watchful care of a responsible adult other than the operator.
- Be alert and turn mower off if a child enters the area.
- Before and while moving backwards, look behind and down for small children or other objects.
- Never allow children under age 14 to operate the mower. Children 14 years of age and above should read and understand the operation instructions and safety rules in this manual.
- Use extreme care when approaching blind corners, shrubs, trees, or other objects that may obscure your vision of a child or hazard.

## Service

- Use extreme care in handling gasoline and other fuels. They are extremely flammable and the vapors are explosive.
- Use only an approved gasoline container.
- Never remove gas cap or add fuel while the engine is running. Allow engine to cool at least two minutes before refueling.

- Replace gasoline cap securely and wipe off any spilled gasoline before starting the engine as it may cause a fire or explosion.
- Extinguish all cigarettes, cigars, pipes and other sources of ignition.
- Never refuel machine indoors because flammable vapors will accumulate in the area.
- Never store the machine or fuel container inside where there is an open flame or spark such as a gas water heater, space heater, or furnace.
- Never run an engine inside a closed area.
- To reduce fire hazard, keep mower free of grass, leaves, or other debris build-up. Clean up oil or fuel spillage. Allow mower to cool at least 5 minutes before storing.
- Before cleaning, repairing, or inspecting, make certain the blade and all moving parts have stopped. Disconnect the spark plug wire, and keep the wire away from the spark plug to prevent accidental starting.
- Check the blade and engine mounting bolts at frequent intervals for proper tightness. Also, visually inspect blade for damage (e.g., bent, cracked or worn). Replace with blade which meets original equipment specifications listed in this manual.
- Keep all nuts, bolts, and screws tight to be sure the equipment is in safe working condition.
- Never tamper with safety devices. Check their proper operation regularly.
- After striking a foreign object, stop the engine, remove the wire from the spark plug, and thoroughly inspect the mower for any damage. Repair the damage before starting and operating the mower.
- Never attempt to make a wheel or cutting height adjustment while the engine is running.
- Grass catcher components are subject to wear, damage and deterioration, which could expose moving parts or allow objects to be thrown. For safety protection, frequently check components and replace with manufacturer's recommended parts, when necessary.
- Mower blades are sharp and can cut. Wrap the blade(s) or wear gloves, and use extra caution when servicing them.
- Do not change the engine governor setting or overspeed the engine. Excessive engine speeds are dangerous.

## YOUR RESPONSIBILITY



Restrict the use of this power machine to persons who read, understand and follow the warnings and instructions in this manual and on the machine.

Following are representations of the safety labels on your lawn mower. Maintain safety while operating the mower. Please have the part number ready when re-ordering safety labels.



**SAVE THESE INSTRUCTIONS FOR FUTURE REFERENCE.**

# SLOPE GAUGE

USE THIS PAGE AS A GUIDE TO DETERMINE SLOPES WHERE YOU MAY NOT OPERATE SAFELY:

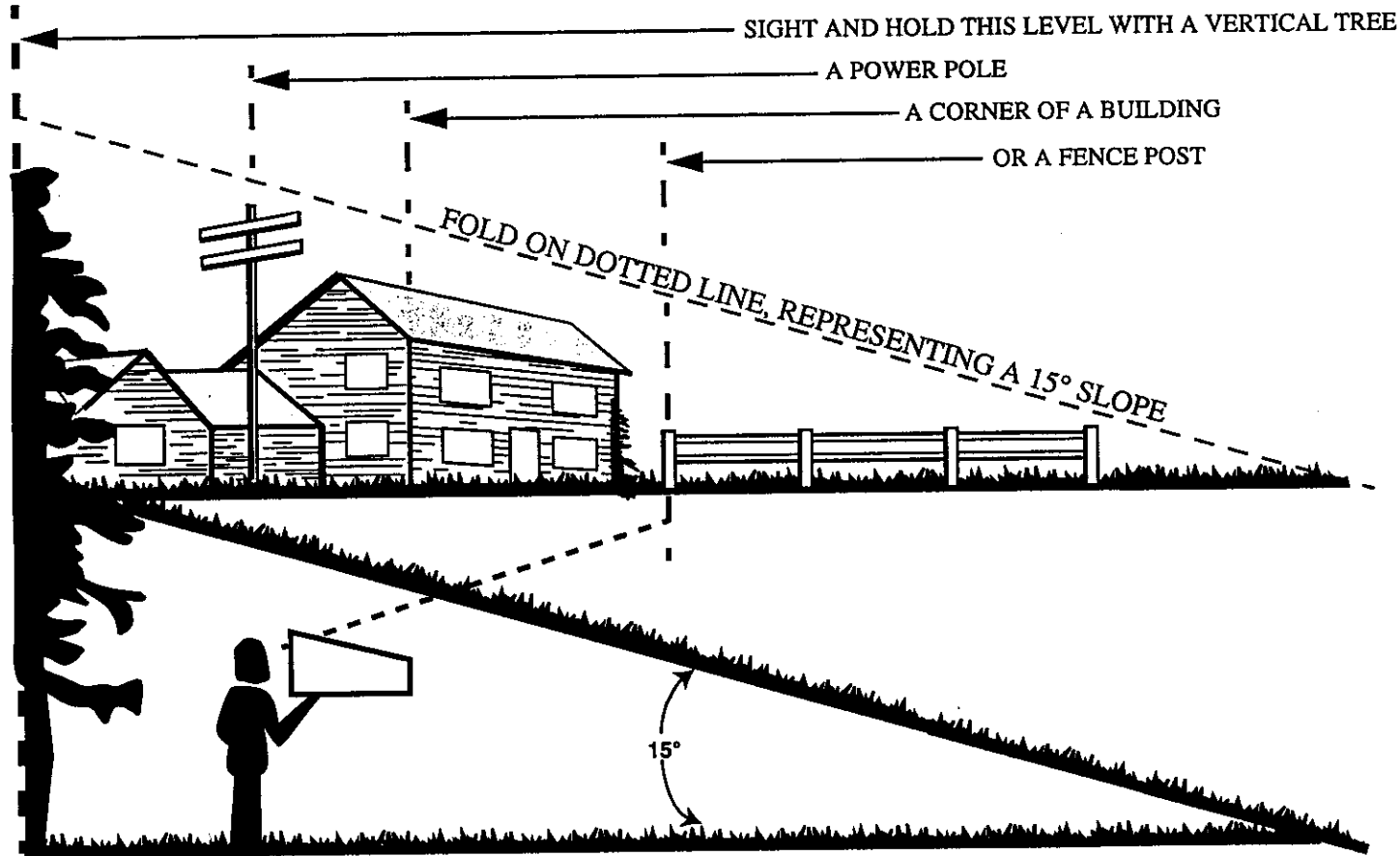

## WARNING

Do not mow on inclines with a slope in excess of 15 degrees (a rise of approximately 2-1/2 feet every 10 feet). A riding mower could overturn and cause serious injury. If operating a walk-behind mower on such a slope, it is extremely difficult to maintain your footing and you could slip, resulting in serious injury. Operate RIDING mowers up and down slopes, never across the face of slopes. Operate WALK-BEHIND mowers across the face of slopes, never up and down slopes.

# ASSEMBLY

## Removing Unit From Carton

- Remove staples, break glue on top flaps, or cut tape at carton end and peel along top flap to open carton.
- Remove loose parts if included with unit (i.e., owner's manual, etc.).
- Cut along dotted lines and lay carton down flat.
- Remove packing material. Roll unit out of carton. Check carton thoroughly for loose parts.

**Note:** Make sure not to crimp the cable while removing loose parts or the unit from the carton.

**IMPORTANT:** This unit is shipped **without gasoline or oil in the engine**. Be certain to service engine with gasoline and oil before operating your mower.

**NOTE:** Reference to right or left hand side of the mower and/or front or behind the mower is observed from the operating position.

## Loose Parts

- a. Owner's Manual
- b. A Bottle of Engine Oil
- c. Parts for Grass Bag: Frame, Bag
- d. Discharge Chute

## Tools Required

- a. Pair of Pliers
- b. Funnel

## Disconnecting Spark Plug

- Before setting up your lawn mower, disconnect the spark plug wire from the spark plug, and ground it against the engine. See Figure 1.
- Attach rubber boot to a bolt on the engine to ground as shown below.

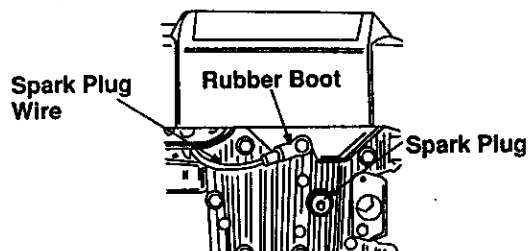

Figure 1

## Assembling Handle

- Raise lower handle in direction A shown in Figure 2. It should snap into place.

**Note:** Make sure to route the cable inside the lower handle. Also do not crimp the cable while lifting the handle up

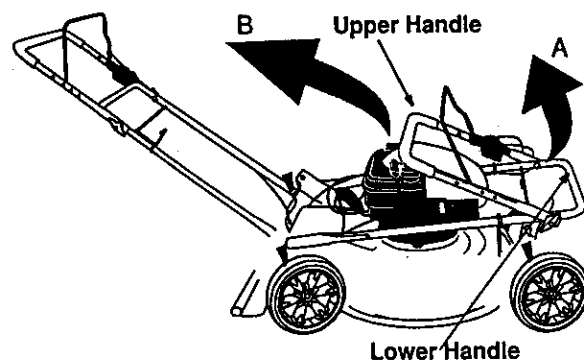

Figure 2

For shipping purposes, the hairpin clip is placed in the outer hole of the weld pin on the lower handle.

- Remove the hairpin clip from the outer hole of the weld pin. See Figure 3.

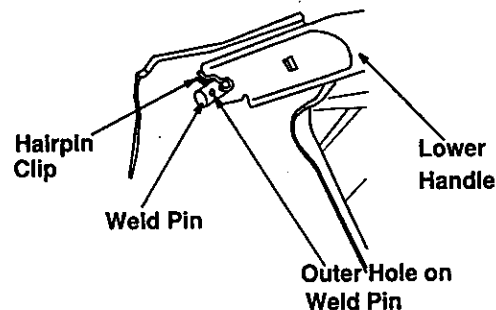

Figure 3

- Using a pair of pliers, insert the hairpin clip into the inner hole in the weld pin. See Figure 3. Repeat on other side.
- Raise the upper handle in the direction B shown in Figure 2. Tighten the wing nuts which are already on the handle.
- Attach control cable to the lower handle with the cable tie already on the lower handle. Pull tight the cable tie and cut off extra. See Figure 4.

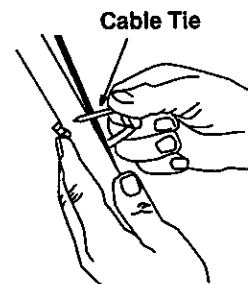

Figure 4

## Attaching Starter Rope

The rope guide is already attached to the right side of the upper handle of your mower. See Figure 5.

- With the spark plug wire disconnected and grounded, hold the blade control handle against the upper handle, and pull starter rope out of the engine.
- Slip the rope through the rope guide as shown in Figure 5. Tighten the wing nut holding the rope guide to the upper handle.

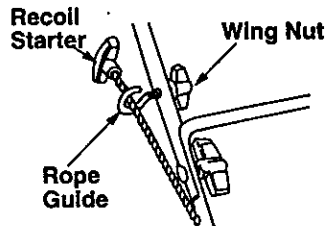

Figure 5

## Attaching Discharge Chute

- There is a groove 2" from the left end of the rod. Bend and snap off approximately 2" of the rod with a pair of vise grips. See Figure 6.
- Insert push cap, provided with the chute rod, onto the end of the rod which you just snapped off. Tap on with a hammer. See Figure 6.

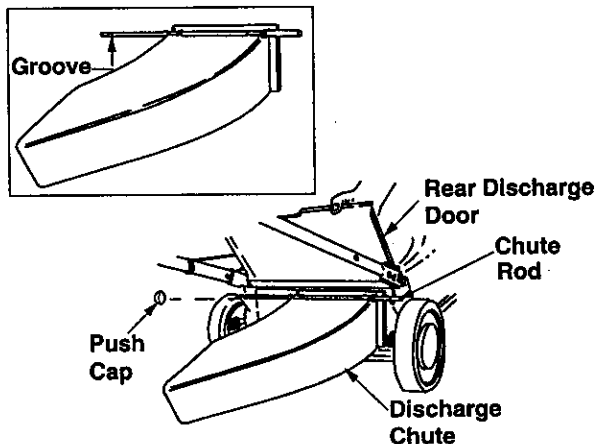

Figure 6

- **To attach discharge chute:** Lift the discharge door and place the ends of the chute rod into the slot on each handle bracket assembly. Release the rear discharge door.
- **To remove discharge chute:** Lift the rear discharge door of the mower. Lift the discharge chute up and outwards and pull it out of the slots on the handle bracket assemblies. Release the rear discharge door.

## Assembling Grass Catcher

**NOTE:** Make certain bag is turned right side out before assembling (warning label will be on the outside).

- Place bag over frame (black plastic side is the bottom of bag). Slip the openings in the side of the plastic channel on bag over the hooks on the grass catcher frame.
- Secure bag to frame by working the plastic channels on bag over frame as shown in Figure 7. All of the plastic channels except center top of bag attach from the outside of bag. Center top of bag attaches from the inside of bag.

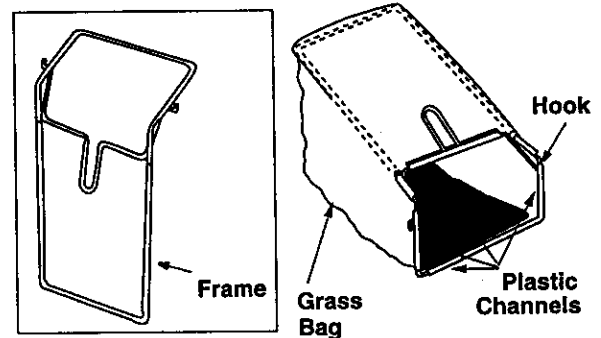

Figure 7

## Attaching Grass Catcher to Mower

- Lift the chute door on the mower. Remove the mulching plug or the discharge chute. See Figure 8.

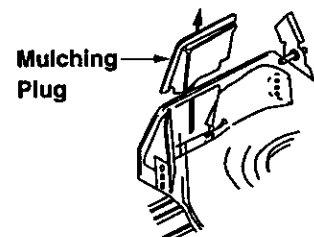

Figure 8

- Holding the grass bag firmly, place the bag on the mower as shown in Figure 9.

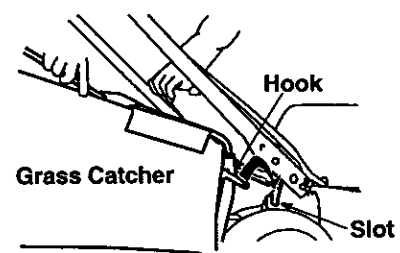

Figure 9

- Place hooks, located on two sides of the grass catcher frame, in the slots on the handle brackets. See Figure 9. Release the chute door.



**Warning:** Never operate the mower unless the grass catcher frame is firmly seated on the chute door pivot rod, and the rear discharge door rests firmly on top of the grass catcher.



# OPERATION

## Know Your Lawn Mower

Read this owner's manual and safety rules before operating your lawn mower. Compare the illustrations in Figure 10 with your lawn mower to familiarize yourself with the location of various controls and adjustments. Save this manual for future reference.



**WARNING:** The operation of any lawn mower can result in foreign objects being thrown into the operator's eyes and causing severe eye damage. **Always wear safety glasses while operating the mower, or while performing any adjustments or repairs on it.**

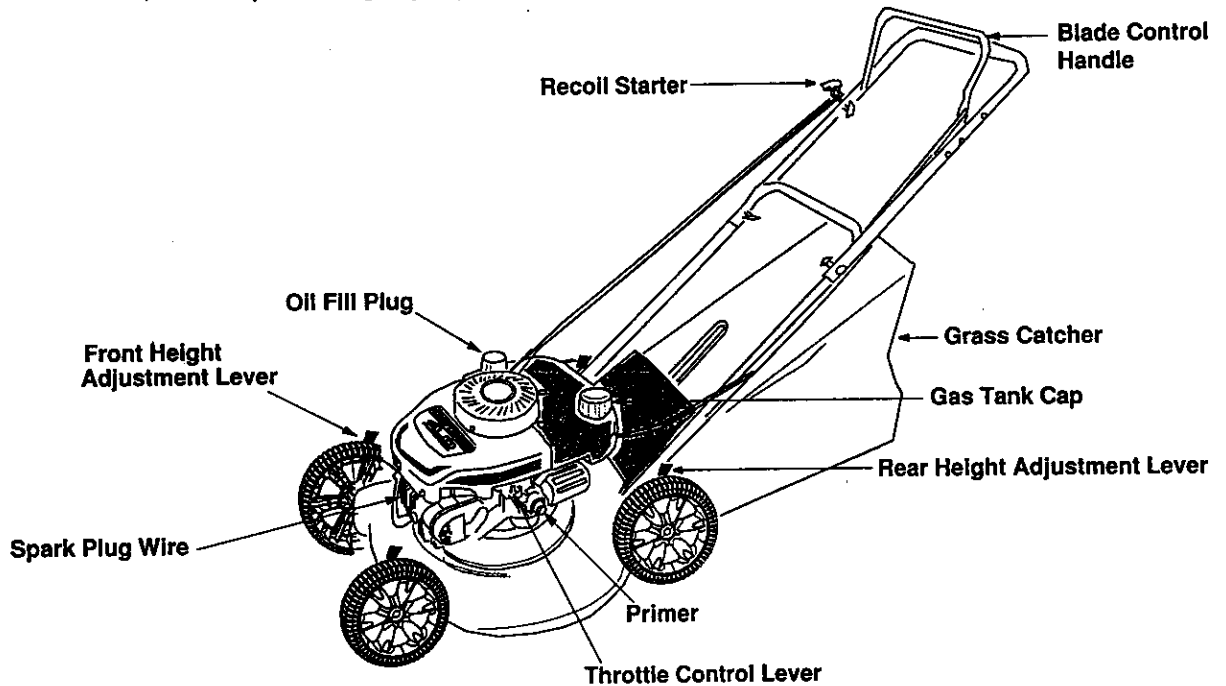

Figure 10

### Recoil Starter

The recoil starter is attached to the handle. Stand behind the unit and pull the recoil starter to start the unit.

### Primer

The primer is used to pump gas into the carburetor. Use it to start a cold engine, but do not use it to restart a warm engine after short shutdown.

### Blade Control Handle

The blade control handle is located on the upper handle of the mower. The blade control handle must be depressed in order to operate the unit. Release blade control handle to stop engine and blade.



**WARNING:** This blade control mechanism is a safety device. **Never attempt to bypass its operations.**

### Height Adjustment Lever

These levers are located on each wheel and are used to adjust the cutting height. All four levers have to be at the same relative position to ensure uniform cut.

---

## Meets CPSC Blade Safety Standards

Craftsman Walk-Behind Lawn Mowers conform to the safety standards of the American National Standards Institute and the U.S. Consumer Product Safety Commission.

---

## Stopping Engine

- Release blade control handle to stop the engine and the blade.
- Disconnect spark plug wire and move away from spark plug to prevent accidental starting.



**WARNING:** Before using your lawn mower, again refer to the safety rules on pages 3-5 of this manual. Always be careful.

## Gas And Oil Fill-Up

### Engine Oil

Only use high quality detergent oil rated with API service classification SF, SG or SH. Select the oil's viscosity grade according to your expected operating temperature. Follow the chart below.

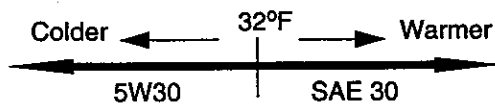

Oil Viscosity Grade Chart

- Use SAE30 oil; *do not use* 10W40 oil.
- Fill oil sump and check the oil level as follows:
  - a. Position the mower on level ground.
  - b. Clean area around oil fill plug.
  - c. Remove oil fill plug and dipstick.
  - d. Wipe dipstick clean, insert it into oil fill hole and tighten securely.
  - e. Remove dipstick and check oil level. If the oil is not upto FULL mark on the dipstick, pour recommended oil through the oil fill and check the level again.
- Install oil fill plug and dipstick, tighten securely.

**NOTE:** Although multi-viscosity oils (5W30, 10W30, etc.) improve starting in cold weather, these multiviscosity oils will result in increased oil consumption when used above 32°F. Check the oil level more frequently to avoid possible engine damage from running low on oil.

### Gasoline



**WARNING:** Never fill fuel tank indoors, or when engine is running or hot. Do not smoke when filling fuel tank.

- Clean area around gas tank cap. For location, see Figure 10. Remove cap.
- Use a funnel to prevent spillage.
- Pour approximately 1.5 quarts of fresh, regular grade, unleaded gasoline slowly to the fuel tank.

**IMPORTANT:** Never mix engine oil with gasoline.

- Fill tank to 1/2" below the bottom of the filler neck. Wipe any fuel spillage. Do not fill fuel tank completely. Provide space for fuel expansion.

## Starting Engine

(Refer to Figure 11.)



**WARNING:** Be sure no one other than the operator is standing near the lawn mower while starting or operating.

- Attach spark plug wire to spark plug. Make certain the metal cap on the end of the spark plug wire is fastened securely over the metal tip on the spark plug.



**WARNING:** Never run engine indoors or in enclosed, poorly ventilated areas. Engine exhaust contains carbon monoxide, an odorless and deadly gas.

**WARNING:** Keep hands, feet, hair and loose clothing away from any moving parts on engine and lawn mower.

- Push primer three times. Wait about two seconds between each push. In cold weather around 55° F or below, prime five times. Do not prime to restart a warm engine after a short shutdown.
- Hold control handle against the upper handle. Grasp recoil starter and pull rope out slowly until engine reaches the start of compression cycle (rope will pull slightly harder at this point). See Figure 11 inset. Let the rope rewind slowly.

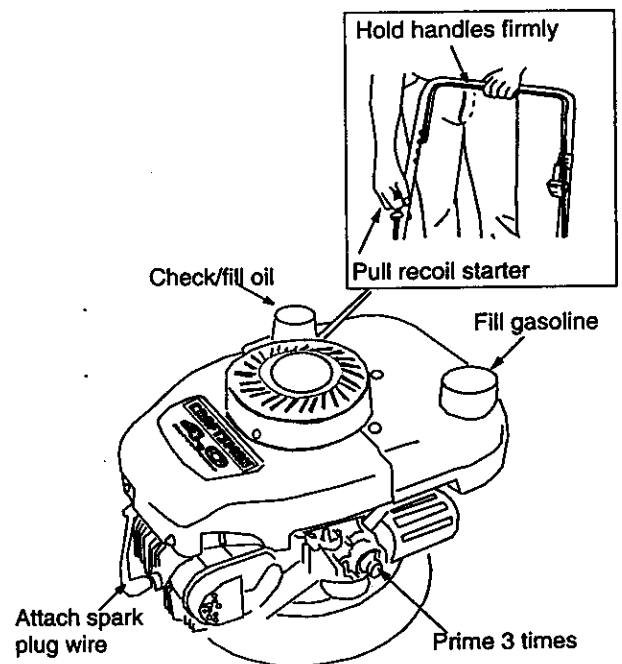

Figure 11

- Pull rope with a rapid, continuous, full arm stroke. Keeping a firm grip on the recoil starter, let the rope return to the starter slowly.

## Using Your Lawn Mower

Your mower is designed to operate as a mulching or a side discharge unit.

- For converting from a mulcher to a side discharge unit, refer to instructions on page 8. **Do not operate mower without the mulching deflector or the grass catcher properly installed and tightly secured.**
- Be sure that lawn is clear of stones, sticks, wire, or other objects which could damage lawn mower or engine. Such objects could be accidentally thrown by the mower in any direction and cause serious personal injury to the operator and others.
- *For best results, do not cut wet grass* because it tends to stick to the underside of the mower, preventing proper discharge of grass clippings, and could cause you to slip and fall. New grass, thick grass or wet grass may require a narrower cut. Blade speed should be adjusted to the condition of the lawn.
- The *best mowing pattern* is one that allows the clippings to discharge towards the uncut part of the lawn. This permits recutting of the clippings to further pulverize them. When cutting high weeds, discharge towards cut portion, then recut at right angles to first direction.
- For a *healthy lawn*, always cut off one-third or less of the total length of the grass. Lawn should be cut in the fall as long as there is growth.
- This mower is designed to be operated at full throttle to give you the *best cut* and do the most effective job of bagging the clippings.



**WARNING:** If the mower strikes a foreign object, **stop the engine.** Remove spark plug wire from spark plug and thoroughly inspect the mower for any damage. Repair the damage before restarting the mower. Extensive vibration during operation is an indication of equipment damage.

## Using Grass Catcher

You can use the grass catcher bag to collect clippings while operating the mower.

- Attach the grass catcher to the mower following instructions on page 8 of this manual.

- Operate the mower till the grass catcher bag is full, or the job has been completed whichever is earlier.
- Stop the engine completely by releasing the blade control handle. Make sure that the unit has come to a complete stop and the blade has stopped rotating. Empty the grass catcher bag as follows.
- Lift the discharge door and pull the grass bag away from the mower as shown in Figure 12.
- Holding the bag firmly, carry the bag away from the mower. Dispose off the clippings appropriately.

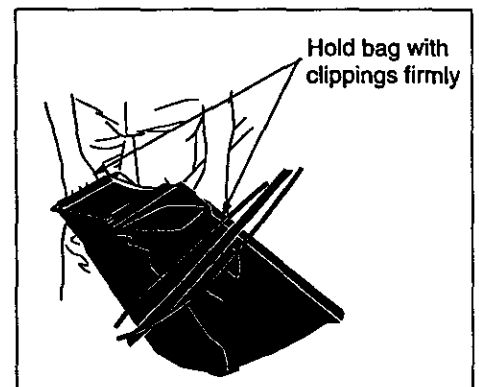
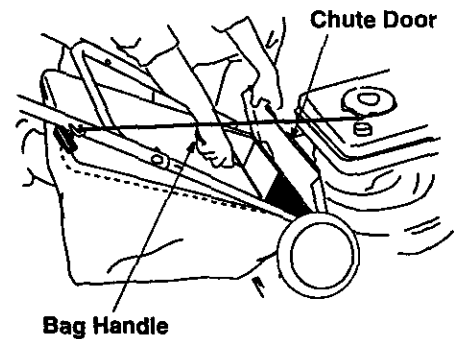

Figure 12

## Height Adjustment

Refer to height adjustments section of this manual on page 16 for instruction on how to adjust the cutting height and the handle height.

For best results in mowing, keep the cutting height position high until it is determined which height is best for your lawn.

# MAINTENANCE

## General Recommendations

- Always observe safety rules when performing any maintenance.
- The warranty on this lawn mower does not cover items that have been subjected to operator abuse or negligence. To receive full value from the warranty, operator must maintain the lawn mower as instructed in this manual.
- Changing of engine governed speed will void engine warranty.
- Some adjustments will have to be made periodically to maintain your unit properly.
- All adjustments in the Service and Adjustments section of this manual should be checked at least once each season.
- Follow the maintenance schedule given below.
- Periodically check all fasteners and make sure these are tight.



**WARNING:** Always stop the engine and disconnect the spark plug wire before performing any maintenance or adjustments.

- Disconnect spark plug wire.
- Drain the gasoline from the lawn mower, or place a piece of plastic under the gas cap.
- Tip the mower so that it rests on the housing. Keep the side with the air cleaner facing up. Hold it firmly.
- Scrape clean the underside of the deck with a suitable tool.
- Put the mower back on its wheels on the ground. If you had put plastic under the gas cap, make sure to remove it now.



**WARNING:** Never tip the mower more than 90 degrees and do not leave the mower tipped for any length of time. Oil can drain into the upper part of the engine causing a starting problem.

**NOTE:** We do not recommend using a garden hose to clean mower unless the muffler, air filter and carburetor are covered to keep water out. Water in engine can shorten engine life.

## Cleaning

The underside of the mower deck should be cleaned after each use to prevent any buildup of grass clippings, leaves, dirt, or other debris. If this debris is allowed to accumulate, it will result in rust and corrosion.



**WARNING:** Always stop engine, disconnect spark plug wire, and move it away from spark plug before performing any adjustments or repairs.

## Engine Maintenance

## Customer Responsibilities

MAINTENANCE SCHEDULE		After each use	First two hours	Every 25 hours	Every 50 hours	Every 100 hours	Once a season	Before storage	SERVICE DATES					
PRODUCT	Lubricate wheels						✓							
	Lubricate casters			✓										
	Lubricate blade control						✓							
	Clean deck	✓						✓						
	Blade care			✓				✓						
ENGINE	Change oil		✓	✓										
	Replace air filter					✓								
	Clean engine						✓							
	Check spark plug				✓		✓							
	Check spark arrester (if any)				✓									

## Engine Oil

- Only use high quality detergent oil rated with API service classification SF, SG or SH. Select the oil's viscosity grade according to your expected operating temperature. Refer to page 10 of this manual for viscosity chart.
- Stop engine and wait several minutes before checking oil level. With engine on level ground, the oil must be to FULL mark on dipstick.
- Change engine oil after the first five hours of operation, and every twenty-five hours thereafter.

## To Change Engine Oil

Change oil after first two operating hours and every 25 operating hours thereafter. Drain oil while engine is warm. Follow the instructions given below.

- Tip the mower with the spark plug facing up.
- Place a container under the dipstick. Pull the dipstick out of oil fill.
- Drain the oil sump empty, collecting oil in an approved container.
- Fill oil sump with 21 ounces of fresh SAE 30 oil. Refer to page 10 of this manual for oil fill-up instructions.

## Air Cleaner

The air cleaner prevents damaging dirt, dust, etc., from entering the carburetor and being forced into the engine and is important to engine life and performance. Replace filter once a year or every 100 operating hours, more often if used in extremely dusty conditions.

## To Service Air Cleaner:

- Turn air filter cover counterclockwise and remove the cover and filter from the flange. See Figure 13. Discard filter.

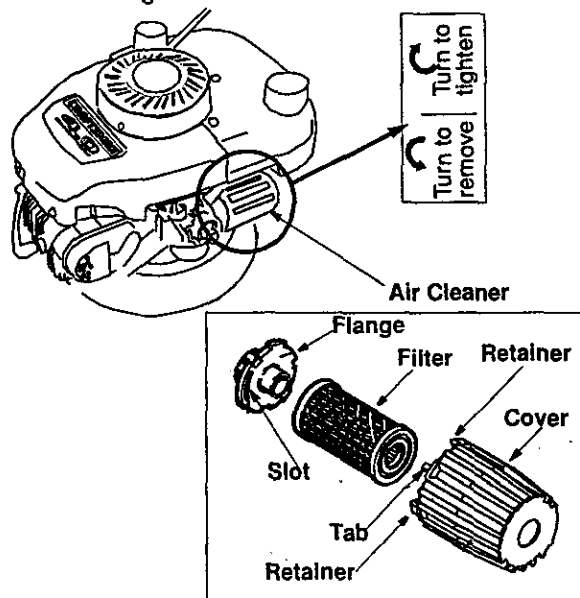

Figure 13

- Clean cover and flange thoroughly.
- Insert the new filter into the cover.
- Place the cover and the filter against flange with tab on the cover inserted into lower left corner of slot in flange. See Figure 13.
- Push cover firmly against flange and turn it clockwise as far as it will go. Make sure that the retainers are locked around the flange. See Figure 13.



**WARNING:** Never run the engine without air cleaner completely assembled.

## Clean Engine

- Clean engine periodically. Remove dirt and debris with a cloth or brush.
- Frequently remove grass clippings, dirt and debris from cooling fins, air intake screen and levers and linkage. This will help ensure adequate cooling and correct engine speed.

**NOTE:** Do not clean with a forceful spray of water as water could contaminate the fuel system.

## Spark Plug

- Clean spark plug and reset gap to .030" at least once a season or every 50 hours of operation. See Figure 14. Spark plug replacement is recommended at the start of each season. Refer to engine parts list for correct spark plug type.

**NOTE:** Do not sandblast spark plug. Spark plug should be cleaned by scraping or wire brushing and washing with a commercial solvent.

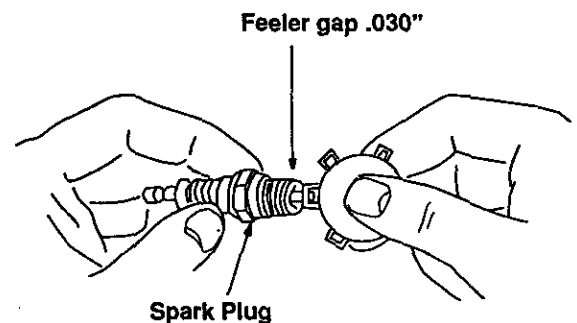

Figure 14

## Muffler



**WARNING:** Do not operate the lawn mower without a muffler, or tamper with the exhaust system. Damaged mufflers or spark arresters could create a fire hazard. Temperature of muffler and nearby areas may exceed 150° F (65°C).

## Blade Care

Periodically inspect the blade adapter for cracks, especially if you strike a foreign object. Replace when necessary.



**WARNING:** When inspecting the cutting blade, protect hands by using heavy gloves or a rag to grasp the cutting blade.

- Disconnect spark plug wire from spark plug.
- Turn mower on its side making sure that the air filter and the carburetor are up to check the blade. If the blade needs to be serviced, refer to the instructions on blade care in the "Service & Adjustments" section of this manual.

## Lubrication

### Wheels

- Lubricate the wheels at least once a season with light oil or engine oil. Also, if the wheels are removed for any reason, lubricate the surface of the axle bolt and the inner surface of the wheel with light oil.

### Blade Control Handle

- Lubricate the pivot points on the blade control handle and the brake cable at least once a season with light oil. The blade control handle must operate freely in both directions. For complete lubrication chart, see Figure 15.

### Chute Deflector

- Lubricate the torsion spring and the pivot point on each end of the chute deflector using a light oil. This will prevent rusting and ensure that the deflector, which is a safety device, can always work properly.

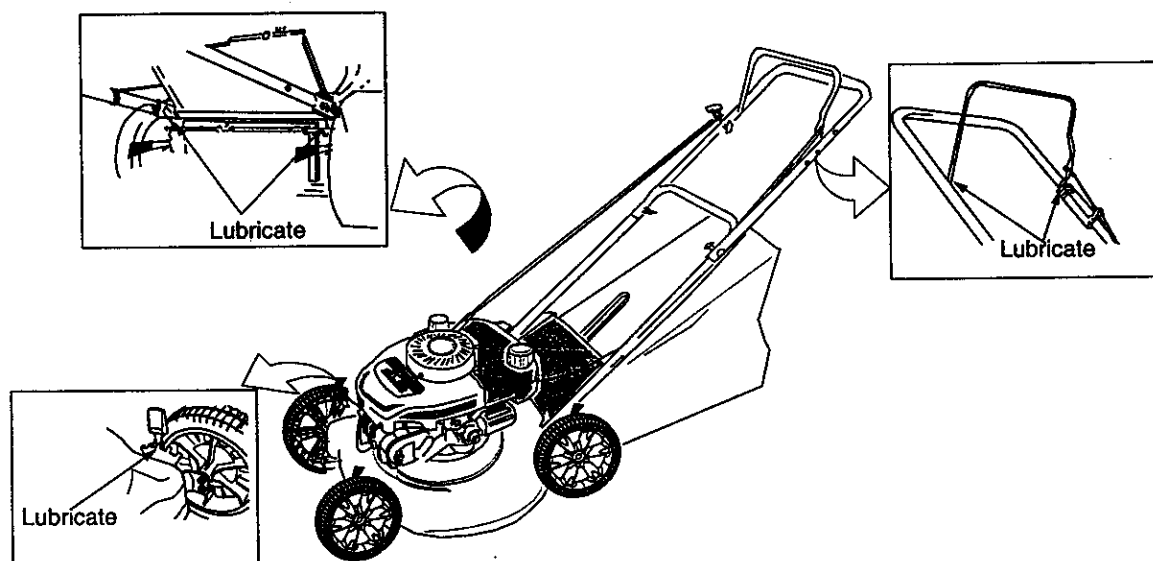

NOTE: For sake of clarity, illustrations in the insets represent view from another perspective rather than from the operating position.

Figure 15: Lubrication Chart

# SERVICE & ADJUSTMENTS

## Servicing Blade

### To Remove Blade

- Remove the bolt and blade bell support which hold the blade and adapter to the engine crankshaft. See Figure 16.
- Remove the blade and adapter from the crankshaft.

### To Replace Blade:

- Before reinstalling the blade and the blade adapter to the unit, lubricate the engine crankshaft and the inner surface of the blade adapter with light oil.
- Install the blade adapter on the crankshaft with the "star" away from the engine. See Figure 16.

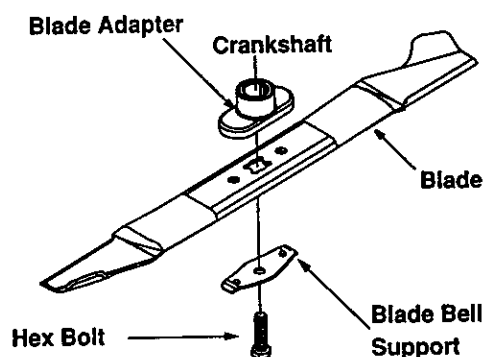

Figure 16

- Place the new blade with the side marked bottom (or with part number) facing away from the adapter.
- Place the bell support next. Make sure to align the tabs in the holes of the blade with the hole in the bell support.
- Insert the hex bolt through the blade assembly. Figure 16 shows the correct order of assembly.
- Use block of wood to hold blade again while you tighten the bolt clockwise. Follow the recommended torque for the bolt which is 450-600 in.-lbs.

**IMPORTANT:** The bolt, used to secure the blade to the engine, is specially heat-treated. **Do not substitute.** To order replacement bolt, refer to the Repair Parts section of this manual.



**WARNING:** To ensure safe operation of your unit, **all nuts and bolts must be checked periodically for correct tightness.**

### To Sharpen Blade:

The blade can be sharpened with a file or on a grinding wheel. Do not attempt to sharpen while on the mower.

- Follow the original angle of grind as a guide. Make sure that each cutting edge receives an equal amount of grinding to prevent an unbalanced blade.

**NOTE:** An unbalanced blade will cause excessive vibration when rotating at high speeds, may cause damage to the mower and could break, causing personal injury.

- Test the blade by balancing it on a round shaft screwdriver or a blade balancer. See Figure 17.
- If the blade is not balanced, remove metal from the heavy side until it balances evenly.

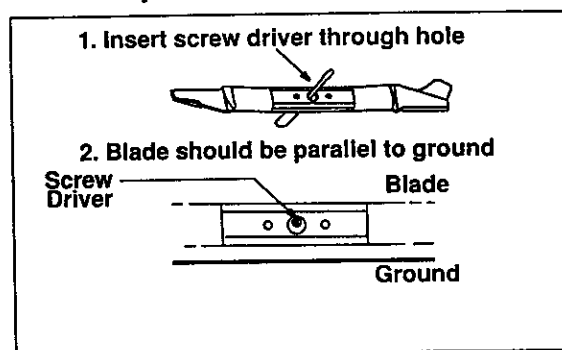

Figure 17

## Engine Adjustments



**WARNING:** Do not make unnecessary adjustments on the engine. Factory settings are satisfactory for most conditions. If any adjustments are made to the engine while the engine is running, **keep clear of all moving parts. Be careful of heated surfaces and muffler. Keep your hands away from these parts.**

### Carburetor

The carburetor has been pre-set at the factory and should not require adjustment.

- If the engine on your mower does not operate properly due to suspected carburetor problems, take your lawn mower to your nearest SEARS service center.
- Engine performance may be affected in altitudes above 4000 feet. To improve engine performance, install a high altitude adjustment kit, available at the SEARS service center.

**NOTE:** A dirty air cleaner will cause an engine to run rough. Be certain air cleaner is clean and attached to the carburetor.

## Engine Speed



**WARNING:** Overspeeding engine above the factory setting can be dangerous. Do not attempt to increase engine speed or it may result in personal injury. Changing of engine governed speed will void engine warranty.

- If you believe the engine is running too fast or too slow, take your lawn mower to the nearest SEARS service center.

## Adjusting Handle Height

Your mower is shipped with the handle in the higher height position. To lower the handle height, proceed as follows.

- Remove the starter rope from the rope guide.
- Remove the upper handle by removing the hand knobs and carriage bolts. Lay the upper handle out of the way, being careful not to bend or kink the cable.
- Remove the hairpin clip from the weld pin on the handle bracket on each side of the lower handle. See Figure 18 inset. Press out on the legs of the lower handle. Remove lower handle from the mower.
- Turn the lower handle around so the notch on the bottom of the lower handle is facing forward as shown in Figure 18. Reassemble, placing the bottom hole on the handle over the weld pin in the handle mounting bracket.
- Reassemble the upper handle to the lower handle.
- Place the hairpin clips in the inner holes in the weld pins and attach the starter rope as instructed in the Assembly section. See Figure 18 inset.

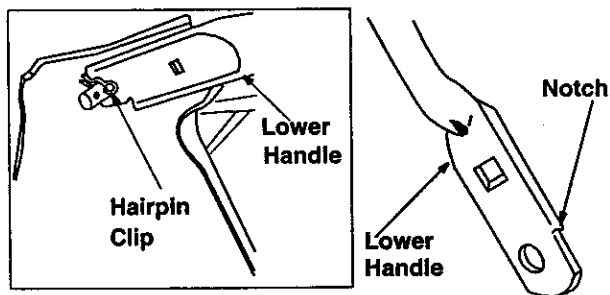

Figure 18

## Adjusting Cutting Height

**IMPORTANT:** All wheels must be placed in the same relative position.

- Raise the mower wheels for low cut and lower the wheels for high cut. For rough or uneven lawns, move the height adjustment lever to a higher position. This will help stop scalping of the grass.

There is an adjusting plate and thumb lever at each wheel position to adjust the cutting height. Each adjusting plate has nine height positions. Height of cut will change if you move the thumb lever from one hole to another.

- Simply depress the lever towards wheel and move the wheel and lever assembly to the desired position. See Figure 19. All wheels must be placed in the same relative position for uniform cutting height.
- For rough or uneven lawns, move the height adjustment handles to positions which will give a higher cutting height. Both front and rear handles must be placed in the same relative position.

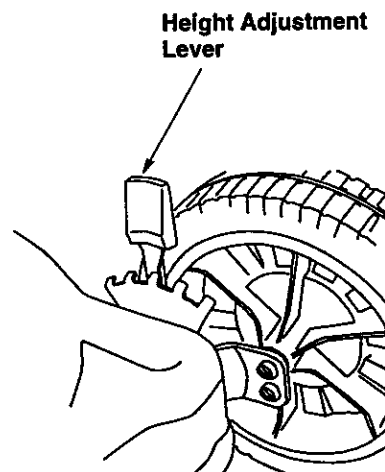

Figure 19



# STORAGE

Prepare your lawn mower for storage at the end of the season or if the unit will not be used for 30 days or more. Store the mower in a clean, dry area.

## Mower

- Clean underside of the mower following instructions in the Maintenance section of this manual.
- Inspect and replace/sharpen blade, if required. Refer to the Maintenance section of this manual for blade care instructions.
- Lubricate mower following the lubrication chart on page 14 of this manual.

You can fold your mower's handle for convenient storage as shown in Figure 20. Follow the steps below to fold the handle.

- Remove the starter rope from the rope guide.
- Loosen the two hand knobs on the sides of the handle, and let the upper handle fold down to the rear.
- Move the hairpin clips to the outer hole in the weld pins on the handle mounting brackets.
- Spread the sides of the lower handle, and push it forward and down.

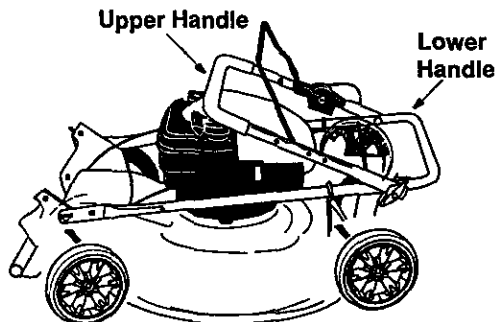

Figure 20

**NOTE:** When folding the handle for storage or transportation, be careful not to bend or kink the cable.

## Engine

**IMPORTANT:** It is important to prevent gum deposits from forming in essential fuel system parts such as carburetor, fuel filter, fuel hose, or tank during storage. Also, experience indicates that alcohol blended fuels (called gasohol or using ethanol or methanol) can attract moisture which leads to separation and formation of acids during storage. Acidic gas can damage the fuel system of an engine while in storage.

## Drain fuel system & carburetor



**WARNING:** Drain fuel into approved container outdoors away from open flame. Be sure engine is cool. Do not smoke.

- Drain the fuel tank.
- Start the engine and let it run until the fuel lines and carburetor are empty.
- Drain carburetor by removing bowl drain screw which is located below the carburetor. See Figure 21.

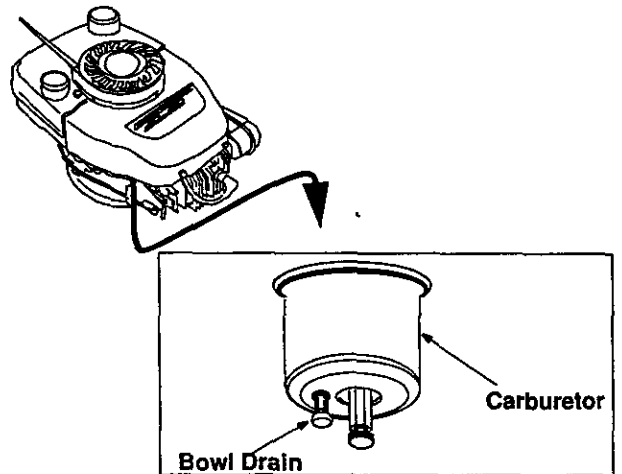

Figure 21

**Note:** Do not drain carburetor if using fuel stabilizer.



**WARNING:** Never use engine or carburetor cleaner products in the fuel tank or permanent damage may occur.

- Use fresh fuel next season.

## Use fuel stabilizer

**NOTE:** Fuel stabilizer is an acceptable alternative in minimizing the formation of fuel gum deposits during storage.

- Add stabilizer to gasoline in fuel tank or storage container.
- Always follow the mix ratio found on stabilizer container.
- Run engine at least 10 minutes after adding stabilizer to allow the stabilizer to reach the carburetor.
- Do not drain the gas tank and carburetor if using fuel stabilizer. Drain all the oil from the crankcase (This should be done after the engine has been operated and is still warm) and refill the crankcase with fresh oil.

### Oil cylinder bore

After you have drained the fuel tank, protect the inside of the engine as follows:

- Remove spark plug, pour approximately one ounce (30 ml) of engine oil into spark plug hole, and crank slowly to distribute oil.



**WARNING:** Avoid spray from spark plug hole when cranking the engine slowly.

- Replace spark plug; do not connect spark plug wire.

### Change oil

- Change oil if it has not been changed in the last three months. For instructions on how to change oil refer to the Maintenance section of this manual.

### Clean engine

- Clean engine and remove any grass clippings, dirt, or chaff from the exterior of the engine.
- Remove any dirt or debris from cooling fins, air intake screen, levers, and linkage.

### OTHER

- Do not store gasoline from one season to another.
- Replace your gasoline can if it starts to rust. Rust and/or dirt in the gasoline will cause problems. Store unit in a clean, dry area. Do not store next to corrosive materials, such as fertilizer.

**NOTE:** *If storing in an unventilated or metal storage shed, be certain to rustproof the equipment by coating with a light oil or silicone.*

# TROUBLE-SHOOTING

PROBLEM	POSSIBLE CAUSE	CORRECTIVE ACTION
Engine fails to start	<ol style="list-style-type: none"> <li>1. Blade control handle disengaged</li> <li>2. Spark plug wire disconnected</li> <li>3. Throttle control lever not in starting position</li> <li>4. Fuel tank empty, or stale fuel</li> <li>5. Blocked fuel line</li> <li>6. Faulty spark plug</li> </ol>	<ol style="list-style-type: none"> <li>1. Engage blade control handle.</li> <li>2. Connect wire to spark plug.</li> <li>3. Move throttle lever to starting position.</li> <li>4. Fill tank with fresh, clean fuel.</li> <li>5. Clean fuel line.</li> <li>6. Clean, adjust gap or replace.</li> </ol>
Engine runs erratic	<ol style="list-style-type: none"> <li>1. Spark plug wire loose</li> <li>2. Blocked fuel line or stale fuel</li> <li>3. Vent in gas cap plugged</li> <li>4. Water or dirt in fuel system</li> <li>5. Dirty air cleaner</li> </ol>	<ol style="list-style-type: none"> <li>1. Connect and tighten spark plug wire.</li> <li>2. Clean fuel line, fill tank with clean, fresh gasoline.</li> <li>3. Clear vent.</li> <li>4. Drain fuel tank. Refill with fresh fuel.</li> <li>5. Clean air cleaner. Refer to Maintenance section of this manual.</li> </ol>
Engine overheats	<ol style="list-style-type: none"> <li>1. Engine oil level low</li> <li>2. Air flow restricted</li> </ol>	<ol style="list-style-type: none"> <li>1. Fill crankcase with proper oil.</li> <li>2. Clean lawn mower engine.</li> </ol>
Occasional skip (hesitates) at high speed	<ol style="list-style-type: none"> <li>1. Spark plug gap too close</li> </ol>	<ol style="list-style-type: none"> <li>1. Adjust gap to .030 inches.</li> </ol>
Idles poorly	<ol style="list-style-type: none"> <li>1. Spark plug fouled, faulty, or gap too wide</li> <li>2. Dirty air cleaner</li> </ol>	<ol style="list-style-type: none"> <li>1. Reset gap to .030 inches or replace spark plug.</li> <li>2. Clean air cleaner following instructions on page 13.</li> </ol>
Excessive vibration	<ol style="list-style-type: none"> <li>1. Cutting blade loose or unbalanced</li> <li>2. Bent cutting blade</li> <li>3. Bent engine crankshaft</li> </ol>	<ol style="list-style-type: none"> <li>1. Tighten blade and adapter, balance blade.</li> <li>2. Replace blade.</li> <li>3. Contact your SEARS Service Center.</li> </ol>
Mower will not mulch grass	<ol style="list-style-type: none"> <li>1. Wet grass</li> <li>2. Excessively high grass</li> <li>3. Dull blade</li> </ol>	<ol style="list-style-type: none"> <li>1. Wait until later to cut.</li> <li>2. Mow once at a high cutting height, then mow again at desired height. Make a narrower cutting swath (1/2) width. Do not cut off more than 1/3 of the total length.</li> <li>3. Sharpen or replace blade.</li> </ol>
Uneven cut	<ol style="list-style-type: none"> <li>1. Wheels not in same height position</li> <li>2. Dull blade</li> </ol>	<ol style="list-style-type: none"> <li>1. Place all four wheels in same relative height position.</li> <li>2. Sharpen or replace blade.</li> </ol>

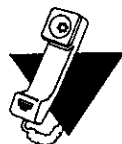

For repairs beyond the minor adjustments listed above, please contact your nearest SEARS Service Center.

# PARTS LIST

## SEARS CRAFTSMAN 4.0 H.P. LAWN MOWER MODEL 247.388240

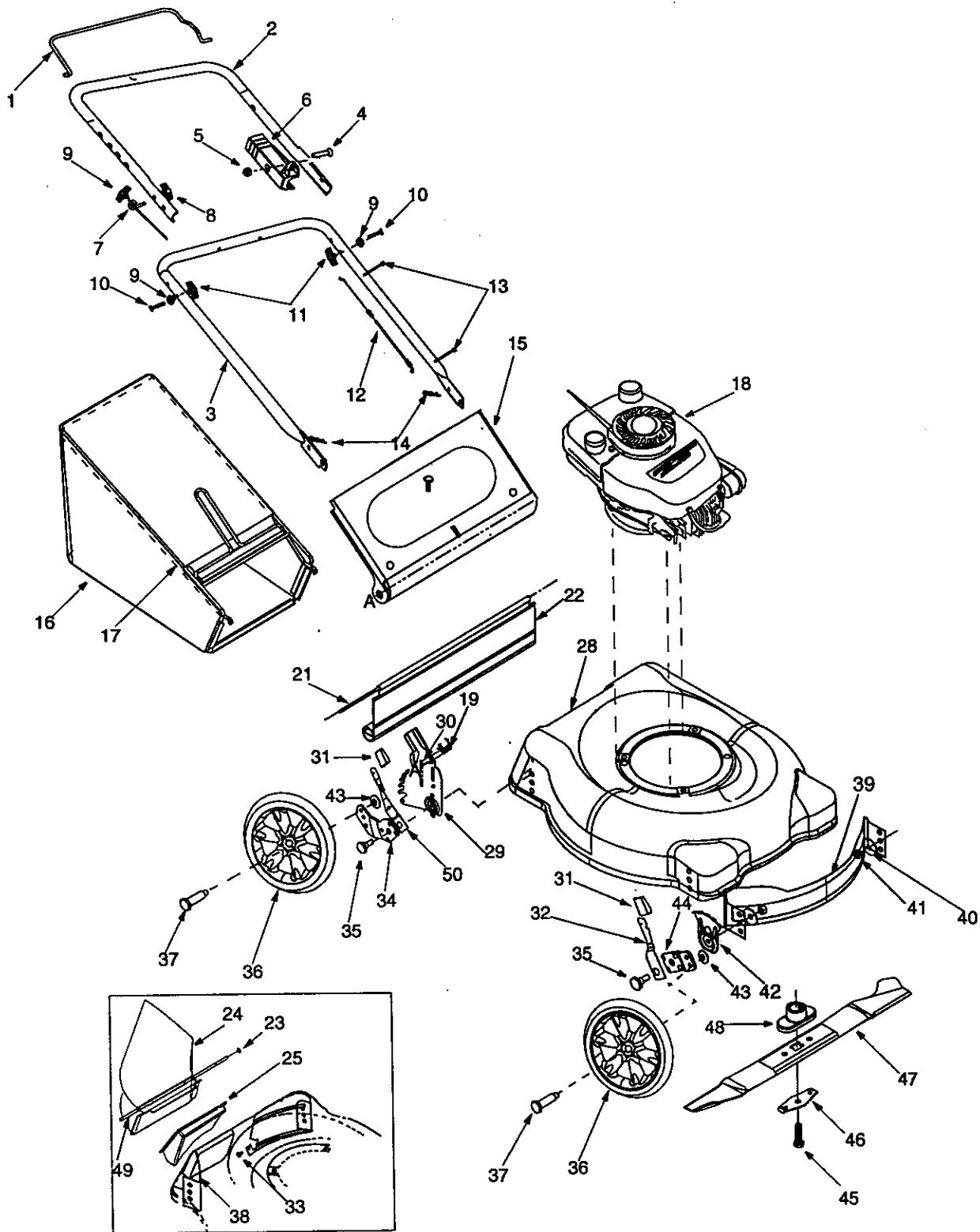

**SEARS CRAFTSMAN 4.0 H.P. LAWN MOWER MODEL 247.388240**

Key No.	Part No.	Description	Key No.	Part No.	Description
1.	747-0824	Blade Control Handle	28.	782-0054A-0689	Cutting Deck
2.	749-0538D-0637	Upper Handle	29.	682-0516	Height Adj. Bracket Assy. RH
3.	749-0928-0637	Lower Handle		682-0515	Height Adj. Bracket Assy. LH (not shown)
4.	710-1270	Oval C-Sunk Scr. 1/4-20 x 1.3"	30.	710-1248	Weld Pin
5.	712-0324	Hex Lock Nut 1/4-20	31.	720-0190	Height Adjustment Knob
6.	746-0883	Cable Housing	32.	732-0404	Spring Lever: Front Wheel
7.	710-1205	Eye Bolt: Rope Guide	33.	710-0654A	Sems Screw TT 3/8-16 x 1.0"
8.	720-0241	Wing Nut 5/16-18	34.	14765	Pivot Bar: 9 Position
9.	736-0451	Saddle Washer	35.	738-0507B	Shoulder Screw
10.	710-0450	Carriage Bolt 5/16-18 x 3.0"	36.	734-1841	Wheel 8 x 1.7 Aero Gray
11.	720-0279	Handle Knob 1/4-20	37.	738-0102	Shoulder Scr. 3/8-16 x 1.445"
12.	746-0737	Control Cable: 51"	38.	782-5004	Rear Baffle RH
13.	726-0240	Cable Tie	39.	782-5025	Front Baffle
14.	714-0104	Hairpin Clip	40.	736-0356	Bell Washer
15.	782-7025	Chute Door: RD	41.	712-0798	Hex Nut 3/8-16
16.	764-0447	Grass Catcher	42.	15261A	Height Adj. Plate
17.	764-0325	Grass Catcher Frame	43.	736-0105	Spring Washer
18.	—	Engine, Tecumseh model 143.994002	44.	15262B	Pivot Bar: Front Wheel
19.	732-0678	Torsion Spring, RH	45.	710-1044	Hex Bolt 3/8-24 x 1.5" Gr.8 Special
20.	732-0677	Torsion Spring, LH	46.	736-0524A	Blade Bell Support
21.	732-0712	Wire: Trail Shield	47.	742-0739	Blade: Mulching
22.	731-1261	Trail Shield	48.	748-0376C	Blade Adapter
23.	726-0201	Speed Nut	49.	711-0996	SD Chute Rod
24.	731-1405	SD Chute: Kit	50.	732-0417A	Spring Lever: Rear Wheel
25.	782-5007A	Mulch Plug			

**CRAFTSMAN ENGINE NO. 143.994002 FOR  
CRAFTSMAN 4.0 H.P. LAWN MOWER MODEL 247.388240**

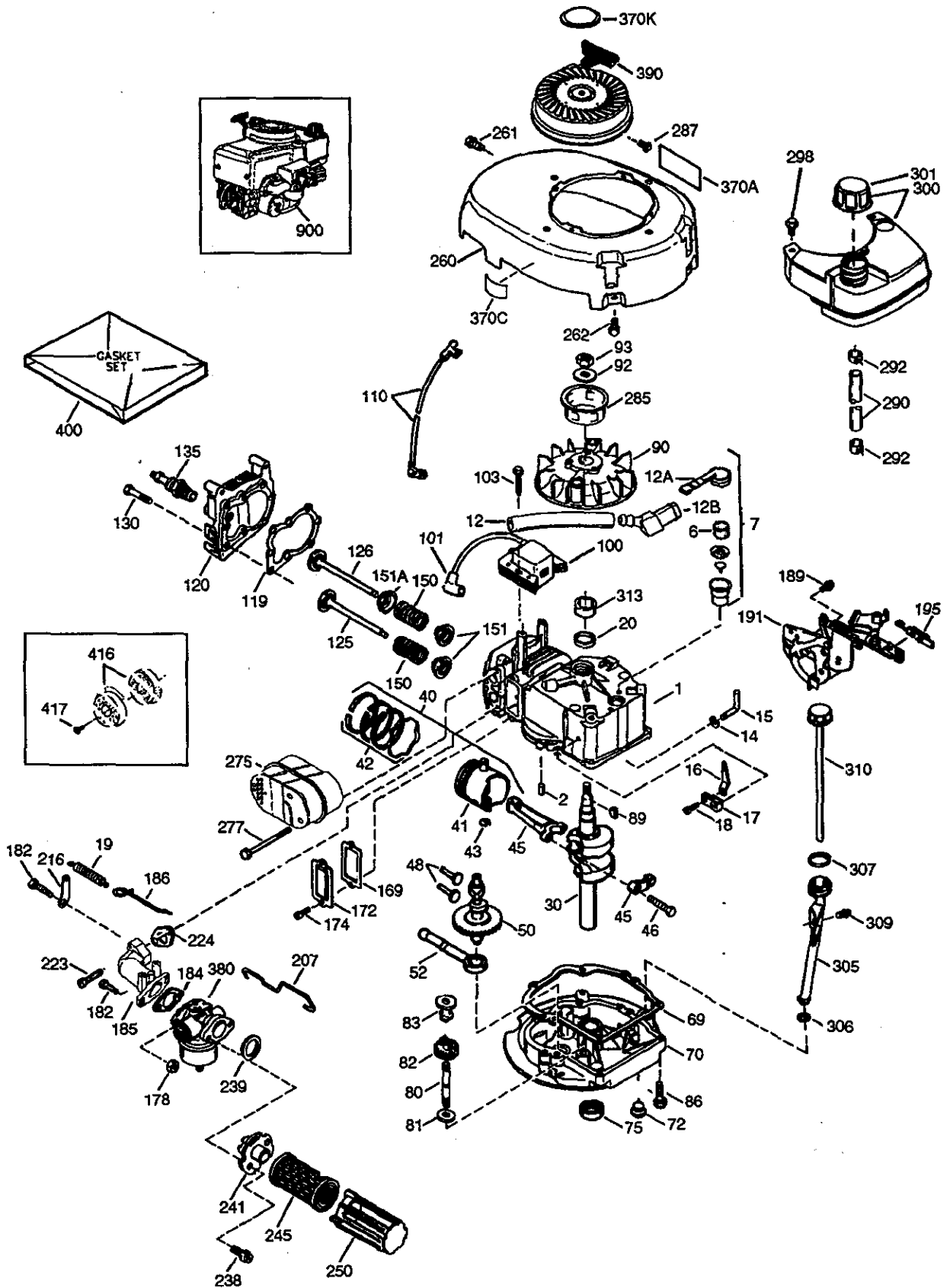

**CRAFTSMAN ENGINE NO. 143.994002 FOR  
CRAFTSMAN 4.0 H.P. LAWN MOWER MODEL 247.388240**

Key No.	Part No.	Description	Key No.	Part No.	Description
1	37280	Cylinder (Incl. 2,20 & 150)	130	6021A	Screw, 5/16-18 x 1-1/2"
2	26727	Dowel Pin	135	35395	Resistor Spark Plug (RJ19LM)
6	33734	Breather Element	150	31672	Valve Spring
7	36557	Breather Ass'y. (Incl. 6 & 12A)	151	31673	Valve Spring Cap
12	36775	Breather Tube	151A	40017	Intake Valve Seal
12A	36558	Breather Cover & Tube (Incl. 12B)	169	36783	Valve Cover Gasket
12B	36694	Breather Tube Elbow	172	36784	Valve Cover
14	28277	Washer	174	30200	Screw, 10-24 x 9/16"
15	30589	Governor Rod (Incl. 14)	178	29752	Nut & Lock Washer, 1/4-28
16	34839A	Governor Lever	182	6201	Screw, 1/4-28 x 7/8"
17	31335	Governor Lever Clamp	184	26756	Carburetor - Intake Pipe Gasket
18	651018	Screw, Torx T-15, 8-32 x 19/64"	185	36785	Intake Pipe
19	36281	Extension Spring	186	32653	Governor Link
20	32600	Oil Seal	189	650839	Screw, 1/4-20 x 3/8"
30	36797	Crankshaft	191	36559A	S.E. Brake Bracket (Incl. 195)
40	35544A	Piston, Pin & Ring Set (Std.)	195	610973	Terminal
40	35545A	Piston, Pin & Ring Set (.010" OS)	207	34336	Throttle Link
40	35546	Piston, Pin & Ring Set (.020" OS)	216	33086	R.P.M. Adjusting Lever
41	35541	Piston & Pin Ass'y. (Std.) (Incl. 43)	223	650451	Screw, 1/4-20 x 1"
41	35542	Piston & Pin Ass'y. (.010" OS) (Incl. 43)	224	36786	Intake Pipe Gasket
41	35543	Piston & Pin Ass'y. (.020" OS) (Incl. 43)	238	650932	Screw, 10-32 x 49/64"
42	35547A	Ring Set (Std.)	239	34338	Air Cleaner Gasket
42	35548A	Ring Set (.010" OS)	241	35797	Air Cleaner Collar
42	35549	Ring Set (.020 OS)	245	35066	Air Cleaner Filter
43	20381	Piston Pin Retaining Ring	250	35065	Air Cleaner Cover
45	36777	Connecting Rod Ass'y. (Incl. 46)	260	36980	Blower Housing
46	32610A	Connecting Rod Bolt	261	30200	Screw, 10-24 x 9/16"
48	27241	Valve Lifter	262	650831	Screw, 1/4-20 x 1/2"
50	37032	Camshaft (NCR)	275	36790A	Muffler
52	29914	Oil Pump Ass'y.	277	650988	Screw, 1/4-20 x 2-5/16"
69	35261	Mounting Flange Gasket	285	35000A	Starter Cup
70	34311E	Mounting Flange (Incl. 72 thru 83,306)	287	650926	Screw, 8-32 x 21/64"
72	36083	Oil Drain Plug	290	29774	Fuel Line
75	27897	Oil Seal	292	26460	Fuel Line Clamp
80	30574A	Governor Shaft	298	28763	Screw, 10-32 x 35/64"
81	30590A	Washer	300	36916	Fuel Tank (Incl. 292 & 301)
82	30591	Governor Gear Ass'y. (Incl. 81)	301	36246	Fuel Cap
83	30588A	Governor Spool	305	35647	Oil Fill Tube
86	650488	Screw, 1/4-20 x 1-1/4"	306	36996	"O"-Ring
89	611004	Flywheel Key	307	35499	"O"-Ring
90	611112	Flywheel	309	650562	Screw, 10-32 x 1/2"
92	650815	Belleville Washer	310	35648	Dipstick
93	650816	Flywheel Nut	313	34080	Spacer
100	34443B	Solid State Ignition	370A	36261	Lubrication Decal
101	610118	Spark Plug Cover	370C	37199	Primer Decal
103	651007	Screw, Torx T-15, 10-24 x 15/16"	370K	36695	Starter Decal
110	37047	Ground Wire	380	640173	Carburetor (Incl. 184)
119	37028	Cylinder Head Gasket	390	590737	Rewind Starter*
120	36825	Cylinder Head	400	37029A	Gasket Set
125	37288	Exhaust Valve (Std.) (Incl. 151)	416	36085	Spark Arrestor Kit (Optional)
126	37289	Intake Valve (Std.) (Incl. 151)	417	650821	Screw, 10-32 x 1/2" (Optional)
			900	0	Replacement Engine NONE, order from 71-9990
			900	0	Replacement Short Block 750836

\* This engine could have been built with 590694 starter

**CRAFTSMAN ENGINE NO. 143.994002 FOR  
CRAFTSMAN 4.05 H.P. LAWN MOWER MODEL 247.388240**

**Carburetor No. 640173**

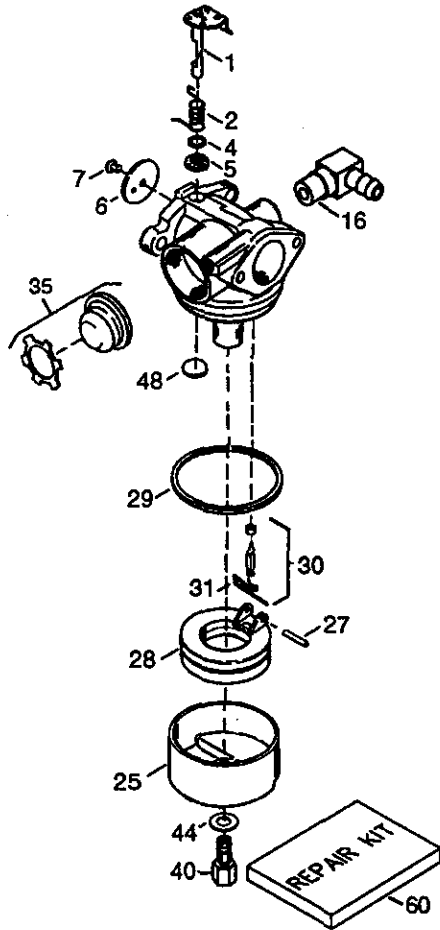

Key No.	Part No.	Description
1	631615	Throttle Shaft & Lever Assembly
2	631767	Throttle Return Spring
4	631184	Dust Seal Washer (Throttle)
5	631183	Dust Seal (Throttle)
6	631616	Throttle Shutter
7	650506	Shutter Screw
16	631807	Fuel Fitting
25	631700	Float Bowl
27	631024	Float Shaft
28	632019	Float
29	631028	Float Bowl "O" Ring
30	631021	Inlet Needle, Seat & Clip (Incl. 31)
31	631022	Spring Clip
35	632047A	Primer Bulb/Retaining Ring
40	631937A	High Speed Bowl Nut
44	631334	Bowl Nut Washer
48	631027	Welch Plug, Atmospheric Vent
60	632760	Repair kit



**CRAFTSMAN ENGINE NO. 143.994002 FOR  
CRAFTSMAN 4.0 H.P. LAWN MOWER MODEL 247.388240**

**Recoil Starter 590694**

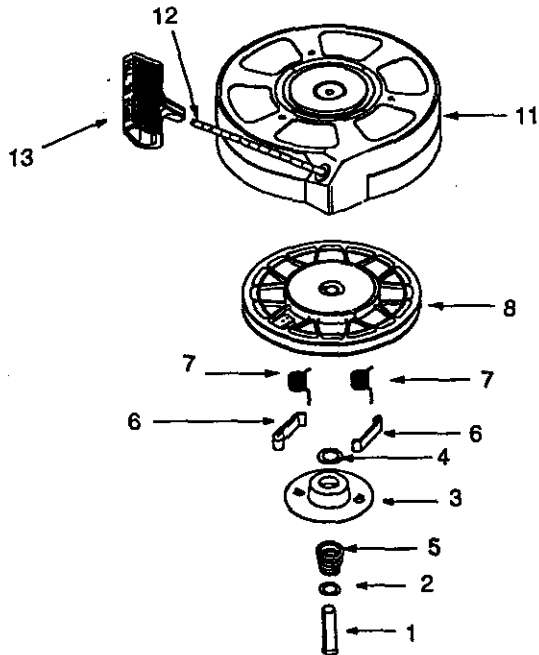

Key No.	Part No.	Description
—	590694	Recoil Starter
1	590599A	Spring Pin
2	590600	Washer
3	590696	Retainer
4	590601	Washer
5	590697	Brake Spring
6	590698	Starter Dog
7	590699	Dog Spring
8	590700	Pulley & Rewind Spring Ass'y.
11	590695	Starter Housing Ass'y. (40 degree grommet)
12	590535	Starter Rope (98" x 9/64" dia.)
13	590701	Starter Handle

**Recoil Starter 590737**

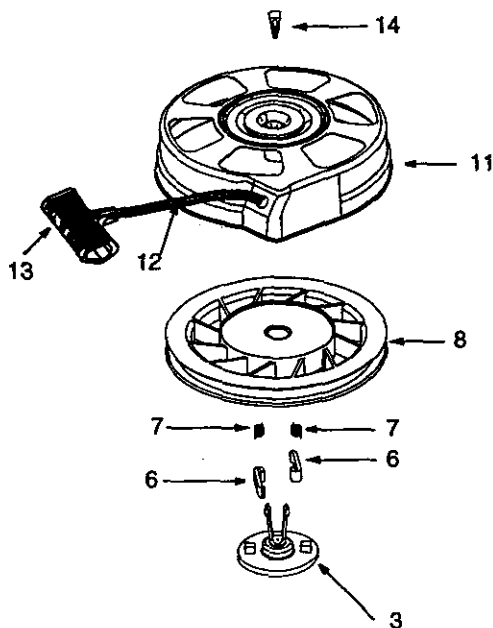

Key No.	Part No.	Description
—	590737	Rewind Starter
3	590740	Retainer
6	590616	Starter Dog
7	590617	Dog Spring
8	590618A	Pulley & Rewind Spring Ass'y.
11	590687A	Starter Housing Ass'y (40 Degree Grommet)
12	590535	Starter Rope (98" X 9/64")
13	590701	Starter Handle
14	590760	Spring Clip

**For in-home major brand repair service:**

Call 24 hours a day, 7 days a week

**1-800-4-MY-HOME<sup>SM</sup> (1-800-469-4663)**

**Para pedir servicio de reparación a domicilio — 1-800-676-5811**

In Canada for all your service and parts needs, call

Au Canada pour tout le service ou les pièces — **1-800-665-4455**

**For the repair or replacement parts you need:**

Call 7 am — 7 pm, 7 days a week

**1-800-366-PART (1-800-366-7278)**

**Para ordenar piezas con entrega a domicilio — 1-800-659-7084**

**For the location of a Sears Parts and Repair Center in your area:**

Call 24 hours a day, 7 days a week

**1-800-488-1222**

**For information on purchasing a Sears Maintenance Agreement  
or to inquire about an existing Agreement:**

Call 9 am — 5 pm, Monday — Saturday

**1-800-827-6655**



The Service Side of Sears<sup>SM</sup>

## Free Manuals Download Website

<http://myh66.com>

<http://usermanuals.us>

<http://www.somanuals.com>

<http://www.4manuals.cc>

<http://www.manual-lib.com>

<http://www.404manual.com>

<http://www.luxmanual.com>

<http://aubethermostatmanual.com>

Golf course search by state

<http://golfingnear.com>

Email search by domain

<http://emailbydomain.com>

Auto manuals search

<http://auto.somanuals.com>

TV manuals search

<http://tv.somanuals.com>