



**3.5 Horsepower  
9 Inch  
EDGER**

**MODEL NO.  
536.772101**



**Caution:**

**Read and follow all Safety Rules  
and Operating Instructions before  
first use of this product.**

**SEARS, ROEBUCK AND CO., Hoffman Estates, IL 60179 U.S.A.**

F-001101M

Download from [Www.Somanuals.com](http://www.Somanuals.com). All Manuals Search And Download.

**SAFETY**

**ASSEMBLY**

**OPERATION**

**MAINTENANCE**

**PARTS LIST**

**ESPAÑOL**

## TABLE OF CONTENTS

WARRANTY STATEMENT	2	SERVICE AND ADJUSTMENT	17
SAFETY RULES	3	TROUBLE SHOOTING CHART	20
INTERNATIONAL SYMBOLS	5	EDGER REPAIR PARTS	21
ASSEMBLY	6	ENGINE REPAIR PARTS	25
OPERATION	10	SPANISH (ESPAÑOL)	31
MAINTENANCE	14	PARTS AND SERVICE	BACK COVER

## WARRANTY STATEMENT

### LIMITED ONE-YEAR WARRANTY ON CRAFTSMAN EDGER

For one year from the date of purchase, when this Craftsman Edger is maintained, lubricated, and tuned up according to the operating and maintenance instructions in the owner's manual, Sears will repair, free of charge, any defect in material or workmanship.

If this Craftsman Edger is used for commercial or rental purposes, this warranty applies for only 90 days from the date of purchase.

This warranty does not cover the following:

- Expendable items which become worn during normal use, such as spark plugs, etc.
- Repairs necessary because of operator abuse or negligence, including bent crank shafts and the failure to maintain the equipment according to the instructions contained in the owner's manual.

**WARRANTY SERVICE IS AVAILABLE BY RETURNING THE CRAFTSMAN EDGER TO THE NEAREST SEARS SERVICE CENTER/DEPARTMENT IN THE UNITED STATES. THIS WARRANTY APPLIES ONLY WHILE THIS PRODUCT IS IN USE IN THE UNITED STATES.**

This warranty gives you specific legal rights, and you may also have other rights which vary from state to state.

Sears, Roebuck and Co., D817WA, Hoffman Estates, IL 60179



### WARNING:



**The engine exhaust from this product contains chemicals known to the State of California to cause cancer, birth defects or other reproductive harm.**

**IMPORTANT:** This unit is equipped with an internal combustion engine and must not be used on or near any unimproved forest-covered, brush-covered or grass-covered land unless the engine's exhaust system is equipped with a spark arrester meeting applicable local or state laws (if any). If a spark arrester is used, it must be maintained in effective working order by the operator.

In the State of California the above is required by law (Section 4442 of the California Public Resources Code). Other states may have similar laws. Federal laws apply on federal lands. A spark arrester/muffler is available through your nearest Sears Service Center (see the REPAIR PARTS section in this manual).

# SAFETY RULES

## Safe Operation Practices for Edger.



**WARNING:** Look for this symbol to point out important safety precautions. It means: "Attention! Become Alert! Your Safety Is Involved."



**WARNING:** To prevent accidental starting when setting-up, transporting, adjusting or making repairs, always disconnect spark plug wire and put wire where it cannot contact the spark plug .

### Before Use

- Read the owner's manual carefully. Be thoroughly familiar with the controls and the proper use of the Edger. Know how to stop the Edger and disengage the controls quickly.
- Do not operate the Edger without wearing adequate outer garments. Wear footwear that will improve footing on slippery surfaces.
- Keep the area of operation clear of all persons, particularly small children and pets.
- Thoroughly inspect the area where the Edger is to be used and remove all foreign objects.

### Fuel Safety

- Handle fuel with care; it is highly flammable.
- Use an approved container.
- Check fuel supply before each use, allowing space for expansion as the heat of the engine and/or sun can cause fuel to expand.
- Fill fuel tank outdoors with extreme care. Never fill fuel tank indoors. Replace fuel tank cap securely and wipe up spilled fuel.
- Never remove the fuel tank cap or add fuel to a running or hot engine.
- Never store fuel or Edger with fuel in the tank inside a building where fumes may reach an open flame.

F-001101M

### Operating Safety

- Never allow children or young teenagers to operate the Edger. Keep them away while it is operating. Never allow adults to operate the Edger without proper instruction.
- Do not operate this machine if you are taking drugs or other medication which can cause drowsiness or affect your ability to operate this machine.
- Do not use this machine if you are mentally or physically unable to operate this machine safely.
- Always wear safety glasses or eye shields during operation or while performing an adjustment or repair to protect your eyes from foreign objects that may be thrown from the Edger.
- Do not put hands or feet near or under rotating parts.
- Exercise extreme caution when operating on or crossing gravel drives, walks, or roads. Stay alert for hidden hazards or traffic.
- Exercise caution to avoid slipping or falling.
- Never operate the Edger without proper guards, plates, or other safety protective devices in place.
- Never operate the Edger at high transport speeds on slippery surfaces. Look behind and use care when backing.
- Never allow bystanders near the Edger.
- Keep children and pets away while operating.
- Never operate the Edger without good visibility or light.
- Do not run the engine indoors. The exhaust fumes are dangerous, containing CARBON MONOXIDE, an ODORLESS and DEADLY GAS.
- Take all possible precautions when leaving the Edger unattended. Stop the engine.
- Do not overload the Edger capacity by attempting to till too deep at too fast a rate.

# SAFETY RULES

## Safe Storage

- Always refer to the owner's manual instructions for important details if the Edger is to be stored for an extended period.
- Never store the Edger with fuel in the fuel tank inside a building where ignition sources are present such as water and space heaters, clothes dryers, and the like. Allow the engine to cool before storing in any enclosure.
- Keep the Edger in safe working condition. Check all fasteners at frequent intervals for proper tightness.

## Repair / Adjustments Safety

- After striking a foreign object, stop the engine. Remove the wire from the spark plug, and keep the wire away from the plug to prevent accidental starting. Thoroughly in-

spect the Edger for any damage, and repair the damage before restarting and operating it.

- If Edger should start to vibrate abnormally, stop engine and check immediately for the cause. Vibration is generally a warning of trouble.
- Stop the engine whenever you leave the operating position. Also, disconnect the spark plug wire before unclogging the blade and when making any repairs, adjustments, or inspections.
- When cleaning, repairing, or inspecting, shut off the engine and make certain all moving parts have stopped.
- Never attempt to make any adjustments while the engine is running except when specifically recommended by the manufacturer.

# SAFETY RULES

## INTERNATIONAL SYMBOLS

**IMPORTANT:** Many of the following symbols are located on your unit or on literature supplied with the product. Before you operate the unit, learn and understand the purpose for each symbol.

### Control And Operating Symbols



Slow



Fast



Fuel



Oil



Primer Button

### Safety Warning Symbols



**WARNING**  
Thrown Objects.  
Keep Bystanders Away.



**WARNING**  
Rotating Parts. Stop Engine.  
Disconnect Spark Wire Before  
Making Adjustments.



**WARNING**



**IMPORTANT**  
Read Owner's Manual  
Before Operating  
This Machine.



**WARNING**  
Wear Eye Protection



**STOP**

# ASSEMBLY

## ASSEMBLY

### Parts Packed Separately In Carton

- 1 – Owner's Manual (not shown)
- 1 – Container Of Oil
- 2 – Hair Pin
- 1 – Control Rod

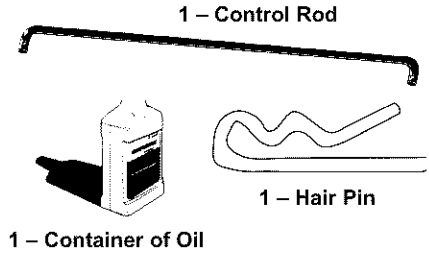

**WARNING:** Always wear safety glasses or eye shields while assembling the Edger.

Figure 1 shows the Edger completely assembled.

References to the right or left side of the Edger are from the viewpoint of the operator's position behind the unit.

### REMOVE THE EDGER FROM THE CARTON

1. Remove the bottle of oil and parts bag

from the carton.

2. Cut down all four corners of the carton.
3. Remove the packing material positioned around the front and rear of the unit. Leave the packing material on the bottom of the unit until the control rod is assembled. This will keep the front wheel in a stable position.
4. Lift the Edger out of the carton and place on a hard level surface.

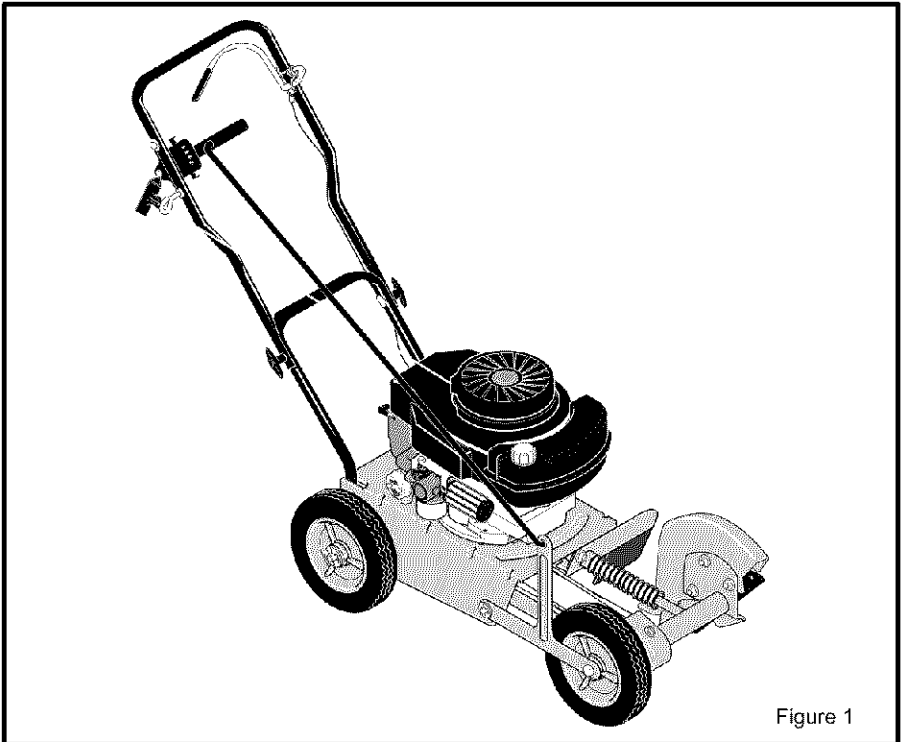
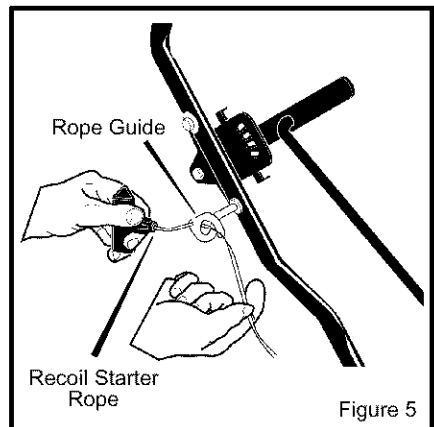
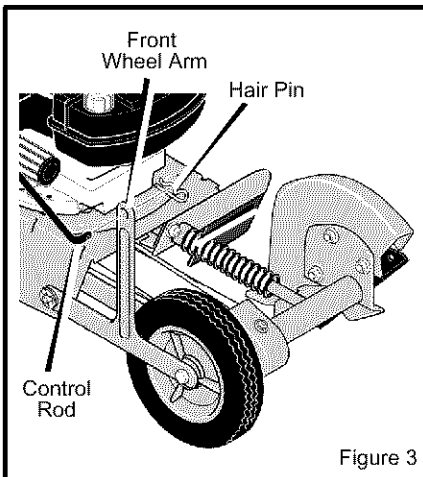
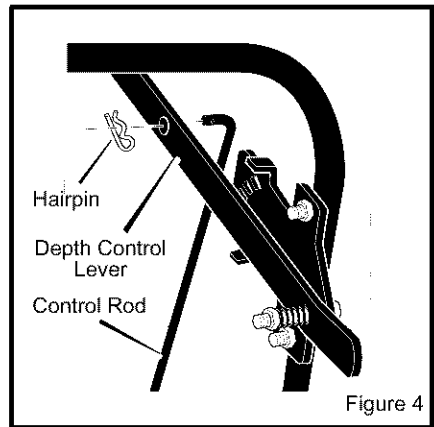
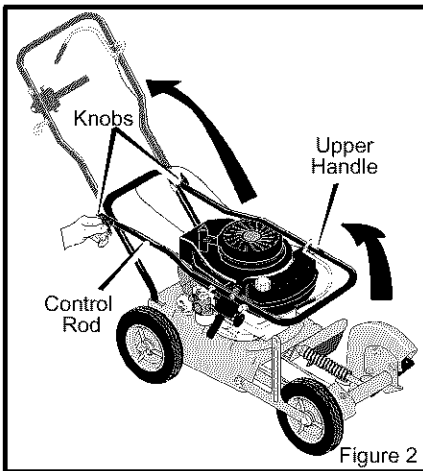

Figure 1

# ASSEMBLY

## HOW TO RAISE THE HANDLE

1. Loosen the **knobs** and raise the upper handle to the upright position. See Figure 2.
2. Tighten the **knobs**. Make sure the **knobs** are to the outside of the handles as shown in Figure 2.
3. Insert the end of the **control rod**, from **RIGHT to LEFT**, through the hole in the **front wheel arm**. Attach with **hair pin** found in parts bag. See Figure 3.
4. Push down on the handle to tilt the unit back.
5. Insert the other end of the **control rod**, from **RIGHT to LEFT**, through the hole in the **depth control lever** and fasten with **hair pin**. See Figure 4.
6. Move the **depth control lever** forward to the **STARTING** and **TRANSPORT** position.
7. Remove any packing material from the bottom of the unit.
8. To attach the **recoil starter rope** to the **rope guide**, twist the **recoil starter rope** through the **rope guide**. See Figure 5.



# ASSEMBLY

## HOW TO PREPARE THE ENGINE

### Fill With Oil

This Edger was shipped with a 20 ounce container of SAE30 motor oil. Add this oil to the engine before operating. To fill the crankcase, remove the oil fill cap/dipstick and add the SAE30 motor oil. DO NOT OVERFILL.

**NOTE:** The engine may contain a small amount of oil. When adding oil, frequently insert the oil fill cap/dipstick and check the amount of oil in the engine. DO NOT OVERFILL.

### Oil Recommendations

Only use high quality detergent oil rated with API service classification SG. Select the oil's SAE viscosity grade according to your expected operating temperature. Although multi-viscosity oils (5W30, 10W30, etc.) improve starting in cold weather, these multi-viscosity oils will result in increased oil consumption when used above 32 degrees. Check the engine oil level more frequently to avoid possible engine damage from running the engine low on oil.

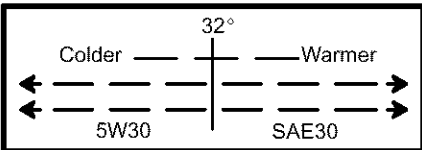

### How To Add The Engine Oil

1. Put the Edger on a level surface.
2. Remove the oil fill cap (Figure 6).
3. Slowly fill the engine crankcase. DO NOT OVERFILL.

### How To Fill With Gasoline

Make sure that the gasoline container is clean and free from dust or other foreign material. Never use gasoline that could be stale from long periods of storage.

1. Remove the fuel cap.
2. Fill the fuel tank with clean, fresh, unleaded grade automotive gasoline.

**WARNING:** Always use a safety fuel container. Do not smoke when adding the fuel mixture to the engine. When inside an enclosure, do not fill the fuel tank. Before you add the fuel mixture, stop the engine. Let the engine cool for several minutes.

**NOTE:** ENGINES WHICH ARE CERTIFIED TO COMPLY WITH CALIFORNIA AND US EPA EMISSION REGULATIONS FOR ULGE ENGINES, are certified to operate on regular unleaded gasoline. Include the following emission control system(s): EM, TWC (if so equipped). Include any user adjustable features – therefore no other adjustments are needed.

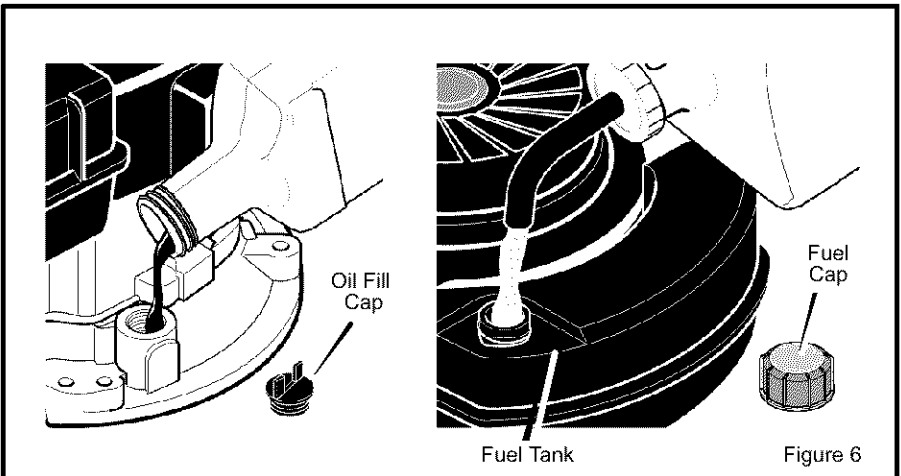



# ASSEMBLY

## ✓ CHECKLIST

For the best performance and satisfaction from this quality product, please review the following checklist before you operate the Edger:

- ✓ All assembly instructions have been completed.
- ✓ Check carton. Make sure no loose parts remain in the carton.
- ✓ All fasteners have been properly tightened.

As you learn how to use the Edger, pay extra attention to the following important items:

- ✓✓ Engine oil is at proper level.
- ✓✓ Fuel tank is filled with a fresh, clean, regular Unleaded gasoline.
- ✓✓ Become familiar and understand the function of all controls. Before your start the engine, operate all controls.

# OPERATION

## KNOW YOUR EDGER

READ THE OWNER'S MANUAL AND ALL SAFETY RULES BEFORE YOU OPERATE the Edger. To familiarize yourself with the location of the controls, compare the illustrations with your Edger. **Save this manual for future reference.**

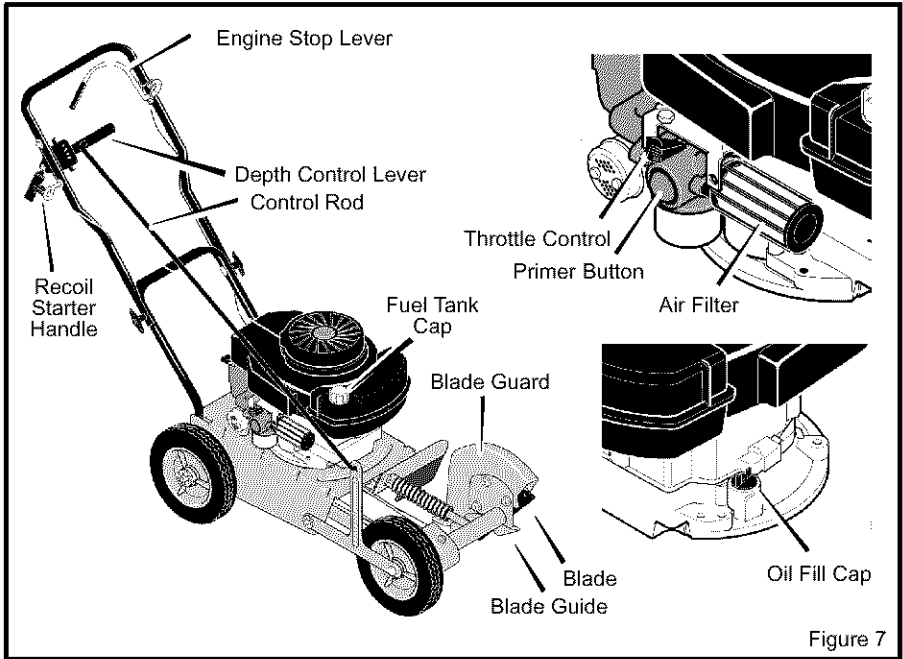

Figure 7

**Throttle Control** – Controls the engine speed.

**Primer Button** – Injects fuel directly into the carburetor for faster starts.

**Recoil Starter Handle** – The engine is equipped with an easy pull recoil starter.

**Depth Control Lever** – Use to control the

depth of cut.

**Blade Guard** – Use to prevent stones or other material from being thrown at the operator.

**Engine Stop Lever** – Must be engaged to allow the engine to start and run. Release to stop the engine.

## EYE PROTECTION

Always wear safety glasses. If you wear eye glasses, put a Wide Vision Safety Mask over your eye glasses.



**WARNING:** Debris thrown from the Edger can result in foreign objects being thrown into the eyes, which can cause severe eye damage. Always wear safety glasses or eye shields when operating the Edger.

# OPERATION



**WARNING:** When the engine runs, the blade will rotate. To prevent injury, keep hands and feet away from blade.

## HOW TO STOP THE EDGER

1. Move the **depth control lever** forward to raise the blade. Then, release the engine stop lever. See Figure 8.



**WARNING:** Never leave the Edger unattended while the engine is running. Always raise the cutting blade and stop the engine.

## HOW TO USE THE ENGINE STOP LEVER

1. Release the **engine stop lever** and the engine and the blade will automatically stop. To run the engine, hold the **engine stop lever** in the operating position. See Figure 8.
2. If the engine continues to run, move the throttle control to the STOP position.

**IMPORTANT:** Before you start the engine, operate the engine stop lever several times. Make sure the engine stop cable moves freely. If the engine stop cable is bent or damaged, replace the cable. If the problem continues, take the Edger to a Sears Service Center to correct the problem.

## HOW TO USE THE DEPTH CONTROL LEVER

1. Start the engine.
2. To lower the cutting blade, pull the depth control lever back.
3. Select the edging depth that you need. There are three selections with an approximately depth of two inches.

**NOTE:** For deep edging, first cut at shallow depths. Then, cut at greater depths until the desired depth is obtained.

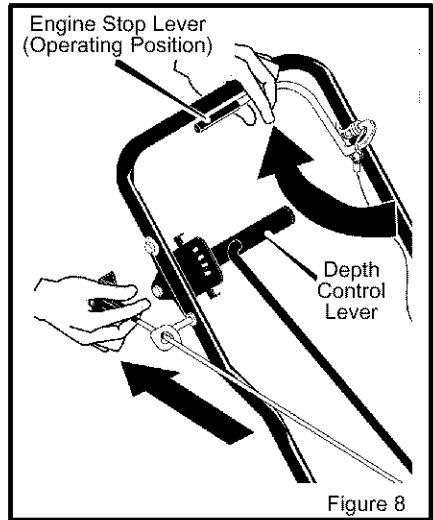

Figure 8

## HOW TO USE THE PRIMER BUTTON

When starting a cold engine, push the **primer button** five times (see Figure 9). Wait approximately two seconds between each push.

**IMPORTANT:** When starting a warm engine, do not use the primer button.

## HOW TO USE THE THROTTLE CONTROL

1. Push the **throttle control** forward to increase engine speed, or pull back to decrease engine speed (see Figure 9).

2. During normal use, run the engine at full speed.

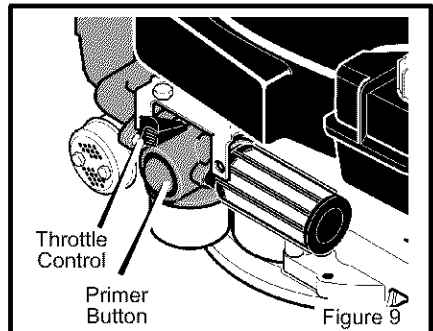

Figure 9

# OPERATION

## HOW TO STOP THE ENGINE

To stop the engine, release the engine stop lever. If the engine continues to run, move the throttle control to the STOP position.

If the engine will not stop, hold a screwdriver against the spark plug and against the engine cooling fins. The spark will go to ground and the engine will stop.

## HOW TO START THE ENGINE



**WARNING:** When the engine runs, the blade will rotate. To prevent injury, keep hands and feet away from blade.

**IMPORTANT:** Before you start the engine, move the edger to the desired location. Operate the controls several times. Make sure all controls move freely.

1. Check the oil.
2. Fill the fuel tank with regular unleaded gasoline. Make sure the gasoline is clean. Leaded gasoline will increase deposits and shorten the life of the valves.

**NOTE:** Do not use gasohol or methanol. Do not use premium unleaded gasoline.



**WARNING:** Always use a safety gasoline container. Do not smoke when adding gasoline to the fuel tank. When inside an enclosure, do not add gasoline. Before you add gasoline, stop the engine and let the engine cool for several minutes.

3. Make sure the spark plug wire is connected to the spark plug.
4. Pull the engine stop lever back to the ENGAGED position. Hold the engine stop lever against the handle.
5. Move the throttle control lever to the FAST position.
6. When starting a cold engine, push the primer button five times. Wait approximately two seconds between each push. See Figure 10.

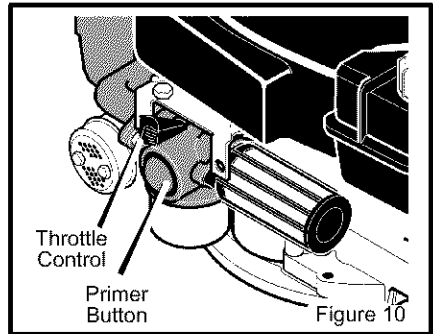

**NOTE:** Do not use the primer button to start a warm engine.

7. To start engine, hold the recoil starter handle firmly with your right hand.
8. Quickly pull the recoil starter handle. DO NOT allow the starter rope to snap back. Let the starter rope slowly rewind. If engine fails to start after three pulls, push primer button two times and again pull the recoil starter handle.
9. When the engine starts, move the throttle control lever to the FAST position. During normal use keep the throttle in the FAST position.
10. If the engine does not start in 5 or 6 tries, see the instructions in the "Trouble Shooting Chart".

**NOTE:** The cutting blade speed is controlled by the engine speed. To reduce the cutting blade speed, decrease the engine speed. To increase the cutting blade speed, increase the engine speed.



**WARNING:** Never run the engine indoors or in a poorly ventilated area. Engine exhaust contains carbon monoxide, an odorless and deadly gas. Keep hands, feet, hair and loose clothing away from any moving parts. Avoid the muffler and surrounding areas. Temperatures can exceed 150 degrees.

# OPERATION

## EDGING TIPS

- Edging is best performed when conditions are dry. If the soil is too wet, dirt becomes packed around the blade causing premature belt wear and decreased performance.
- If dirt does become packed around the blade, stop the engine and remove the wire from the spark plug. Remove the packed dirt and debris from the blade.
- For deep edging, first cut at shallow depths. Then, cut at greater depths until the desired depth is obtained.
- For uniform edging, make sure the blade guide rides on the surface.
- Edging can be customized by varying the number of passes and by the distance the blade is from the surface.



**WARNING: Read the Owner's Manual. Know location and functions of all controls. Keep all safety devices and shields in place. Never allow children or uninstructed adults to operate the Edger. Shut off engine before unclogging blade or making repairs. Keep bystanders away from machine. Keep away from the blade all rotating parts, which cause injury.**

# MAINTENANCE

## CUSTOMER RESPONSIBILITIES

<b>SERVICE RECORDS</b> Fill in dates as you complete regular service.	Before Each Use	Often	Every 10 Hours	Every 25 Hours	Before Each Season	Before Storage	SERVICE DATES
Lubricate All Pivot Points			√			√	
Lubricate Wheel Axles				√		√	
Check Engine Oil Level	√						
Change Engine Oil				√	√		
Replace Air Cleaner Filter					√		
Check Spark Plug				√	√		
Check Drive Belt		√					
Tighten All Fasteners		√					
Check Blade For Wear Or Damage		√					
Lubricate Quill Rod/ tube			√		√	√	

## PRODUCT SPECIFICATIONS

<b>Model No.:</b>	536.772101
<b>Date Of Purchase:</b>	
<b>Horse Power:</b>	3.5
<b>Displacement:</b>	10 cu. in. (163 cc.)
<b>Oil Capacity:</b>	20 oz. SAE-30W
<b>Spark Plug:</b>	Champion RJ19LM
<b>Spark Plug Gap:</b>	0.030 inch

## GENERAL RECOMMENDATIONS

The warranty on this Edger does not cover items that have been subjected to operator abuse or negligence. To receive full value from the warranty, the operator must maintain the Edger as instructed in this manual.

Some adjustments must be made periodically to properly maintain your Edger.

All adjustments in the Service and Adjustments section of this manual must be checked at least once each season.

# MAINTENANCE

## LUBRICATION

After each 25 hours, apply a small amount of engine oil to all moving parts, particularly the wheels.

### How To Change The Engine Oil

Change the oil in the engine crankcase after each 25 hours of use.

**NOTE: The oil will drain more freely when the engine is warm.**

1. Disconnect the spark plug wire from the spark plug.
2. Remove the **oil drain plug** (see Figure 11). Drain the oil into a flat pan.
3. After draining all the oil, install and tighten the **oil drain plug**.
4. Remove the **oil fill cap** (see Figure 12). Fill the engine crankcase. Pour slowly. Do not overfill. See "Product Specifications" for amount and type of oil. Install the **oil fill cap**.
5. Connect the spark plug wire to the spark plug.

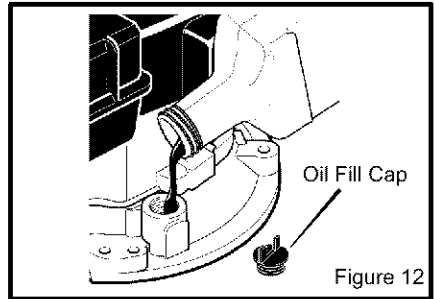
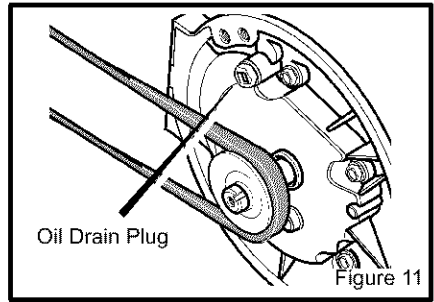

## HOW TO CHANGE THE AIR FILTER

Replace the air filter once a year; more often in dusty or dirty conditions.

**NOTE: DO NOT clean or oil the air filter. The air filter is not serviceable and must be replaced.**

1. Disconnect the spark plug wire from the spark plug.
2. Turn the **cover** to the left (counterclockwise). Remove the **cover** and the **air filter** from the **flange**. (see Figure 13).
3. Discard the **air filter**.
4. Clean the **cover** and the **flange**.
5. Install a new **air filter** into the **cover**.
6. Push the **cover** firmly against the **flange**. Turn the **cover** to the right (clockwise) until tight. Make sure the **retainers** are locked around the **flange**.
7. Connect the spark plug wire to the spark plug.

**CAUTION: Never run the engine without the air filter. A defective air filter will cause a loss of engine power. If dirt or dust enters the engine through the carburetor, the result will be excessive wear or damage to the engine. Replace a damaged or clogged air cleaner immediately.**

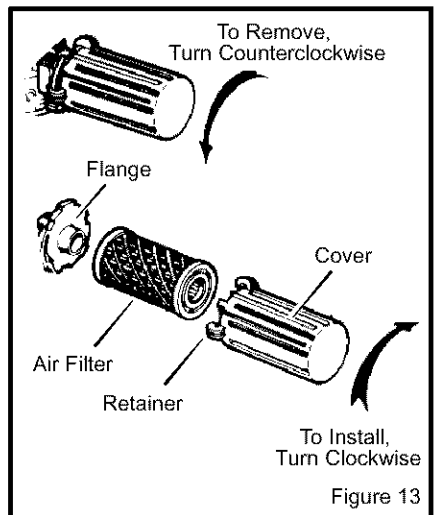

# MAINTENANCE

## SPARK PLUG

Check the **spark plug** every 25 hours. Replace the **spark plug** if the electrodes are pitted, burned, or if the porcelain is cracked.

1. Make sure the **spark plug** is clean. Clean the **spark plug** by carefully scraping the electrodes (do not sand blast or use a wire brush).
2. Check the **spark plug** gap with a **feeler gauge**.
3. Before installing the **spark plug**, coat the threads lightly with oil for easy re-

moval. Tighten the spark plug to a torque of 15 foot-pounds.

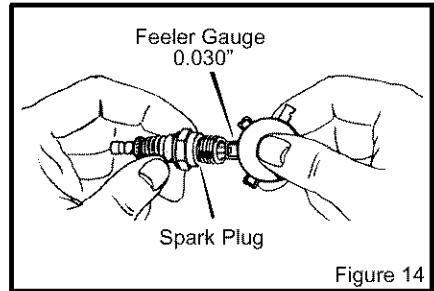

---

## CARBURETOR ADJUSTMENT

Never make unnecessary adjustments to the carburetor. The carburetor was set at the factory to operate efficiently under most applications. However, if adjustments are required, we recommend you contact your nearest Sears Service Center.



**WARNING: The engine governor is set at the factory. Do not change the governor setting.**

**Over speeding the engine above the factory setting can be dangerous. If you think the engine governor needs an adjustment, contact your nearest Sears Service Center.**



# SERVICE AND ADJUSTMENT

## HOW TO REMOVE THE BELT

The belt made of a special compound. If the belt becomes worn or breaks, replace the belt with an original equipment belt.

1. Disconnect the spark plug wire from the spark plug.
2. Drain the gasoline and oil from the engine.
3. Tip the Edger backwards on the handle. Block the top of the handle against a wall or under a bench.
4. Remove the screws from the belt guard (see Figure 15).

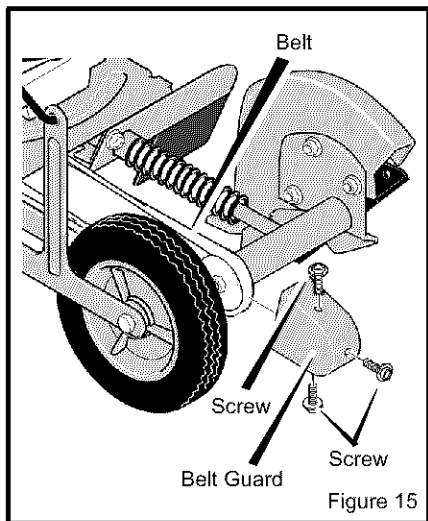

5. To compress the spring and release tension on the belt, push the blade bearing housing back toward the engine (see Figure 16).
6. Carefully note the twist of the belt around the engine pulley. Remove the old belt. Replace with an original equipment belt.
7. To install a new belt, reverse the above steps. Make sure to twist the new belt as shown in Figure 16.

**NOTE: If the belt is not installed properly, the blade will not turn in the proper direction and can damage the blade or belt.**

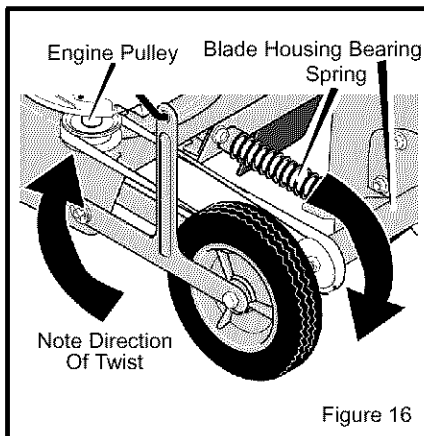

# SERVICE AND ADJUSTMENT

## HOW TO REPLACE THE BLADE

The blade is subject to wear and damage, such as nicks and dents. This will not generally affect its function.

The blade is designed to not require sharpening. Do not attempt to sharpen the blade. The blade is also reversible. If nicks or dents are excessive, remove the blade and turn it around. This will provide a fresh cutting edge. Replace the blade if both sides are worn or damaged.



**WARNING: Do not sharpen the blade. Sharpening can damage the blade and cause it to break, which can cause injury to yourself or to others.**

To replace the **blade**, follow the steps below.

1. Disconnect the spark plug wire from the spark plug.
2. Remove the **blade locknut** that holds the **blade** to the drive shaft.



**WARNING: To remove or tighten the blade locknut, always use the method shown in Figure 17. Always position the holding wrench on the nut behind the blade.**

3. Remove the **blade**.
4. Install a new **blade** and **blade locknut**. Tighten the **blade locknut** to a torque of 40–45 foot pounds.
5. Connect the spark plug wire to the spark plug.

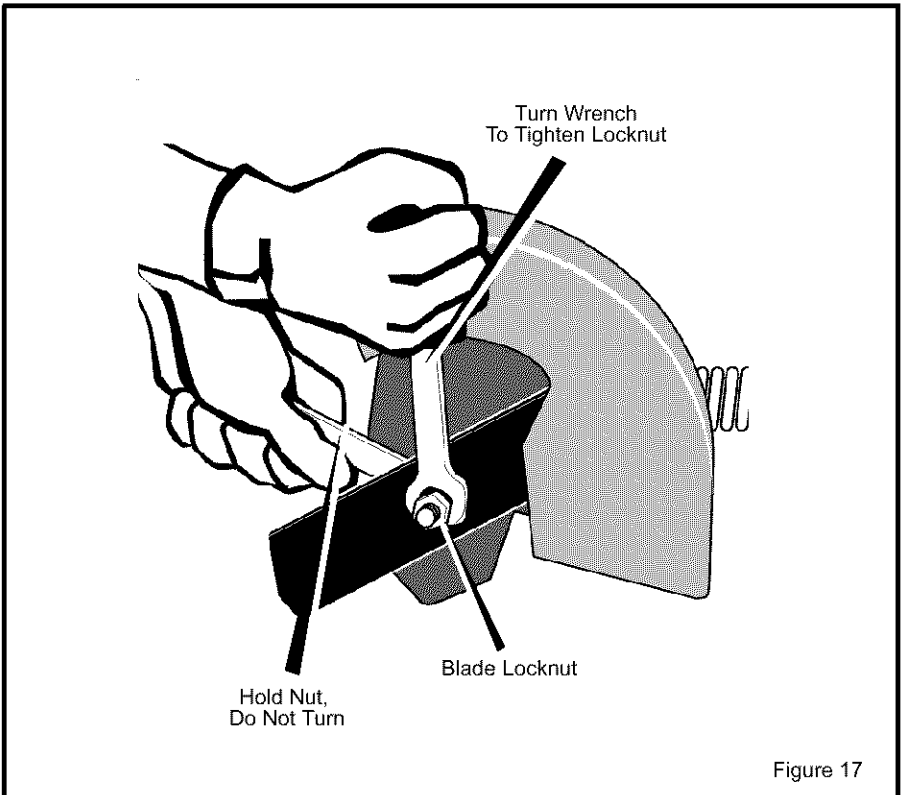

Figure 17

# SERVICE AND ADJUSTMENT

## STORAGE



**WARNING:** Never store the Edger indoors with fuel in the fuel tank. Never store in an enclosed, poorly ventilated area where fumes could reach an open flame, a spark or a pilot light as on a furnace, water heater or clothes dryer.



**WARNING:** Do not remove gasoline while inside a building, near a fire, or while you smoke. Gasoline fumes can cause an explosion or a fire.

When the Edger is put in storage for thirty days or more, follow the steps below to make sure the Edger is in good condition the following season.

### Edger

- Completely clean the Edger.
- Check the Edger for worn or damaged parts. Tighten all loose hardware.
- Apply a small amount of engine oil to all moving parts, particularly the wheels.
- Put the Edger in a building that has good ventilation.
- Cover the Edger with a suitable protective cover that does not retain moisture. Do not use plastic.

**IMPORTANT:** Never cover the Edger while the engine and exhaust areas are still warm.

**NOTE:** A yearly checkup or tune-up by a Sears Service Center is a good way to make sure that your Edger will provide maximum performance for the next season.

### Engine

**IMPORTANT:** It is important to prevent gum deposits from forming in fuel system

parts such as the carburetor, fuel filter, fuel hose, and tank during storage. Also, using alcohol-blended fuels (called gasohol, ethanol or methanol) can attract moisture which leads to separation and formation of acids during storage. Acidic gas can damage the fuel system of an engine while in storage.

To prevent engine damage when the Edger is in storage for 30 days or more, follow the steps below:

- Let the engine run until it is out of gasoline.
- If you do not want to remove the gasoline, add a fuel stabilizer to any gasoline left in the fuel tank. A fuel stabilizer will minimize gum deposits and acids. If the fuel tank is almost empty, mix the fuel stabilizer with fresh gasoline in a separate container and add the mixture to the fuel tank. Always follow the instructions on the stabilizer container. Start the engine. Let the engine run for 10 minutes to allow the mixture to reach the carburetor.
- Change the engine oil. See "How To Change The Engine Oil" in the Maintenance section.
- Lubricate the piston/cylinder area. This can be done by first removing the spark plug and squirting a small amount of clean engine oil into the spark plug hole. Then, cover the spark plug hole with a rag to absorb oil spray. Next, rotate the engine by pulling the starter two or three times. Finally, install the spark plug and attach the spark plug wire.
- Store the Edger in the operating position with the wheels down. If the Edger is stored in any other position, oil from the crankcase will enter the cylinder and cause a service problem.

# TROUBLE SHOOTING CHART

TROUBLE	CAUSE	CORRECTION
<b>Engine difficult to start</b>  or	Stale fuel	Drain fuel tank. Fill with fresh fuel.
	Clogged fuel filter	Replace fuel filter
<b>Engine runs erratically</b>  or	Dirt in fuel tank or out of fuel	Clean fuel tank.
	Carburetor out of adjustment	Take unit to a Sears Service Center.
	Fouled spark plug	Clean and set spark plug gap.
<b>Engine will not run at full speed</b>	Dirty air filter	Replace air filter.
	Plugged air filter	Replace air filter.
<b>Engine smokes excessively</b>	Debris interfering with blade	Clean debris from blade.
	Loose blade	Tighten blade nut.
	Defective V-belt	Replace V-belt.
<b>Blade will not cut properly</b>	Defective quill bearings	Replace the quill assembly.
	Damage or worn blade	Reverse the blade or replace the blade.
<b>Excessive vibration</b>	Loose parts	Stop engine immediately. Tighten all fasteners. If vibration continues, take the unit to a Sears Service Center.
<b>Engine does not shut off when engine control lever is released</b>	Loose handle	Tighten handle knobs.

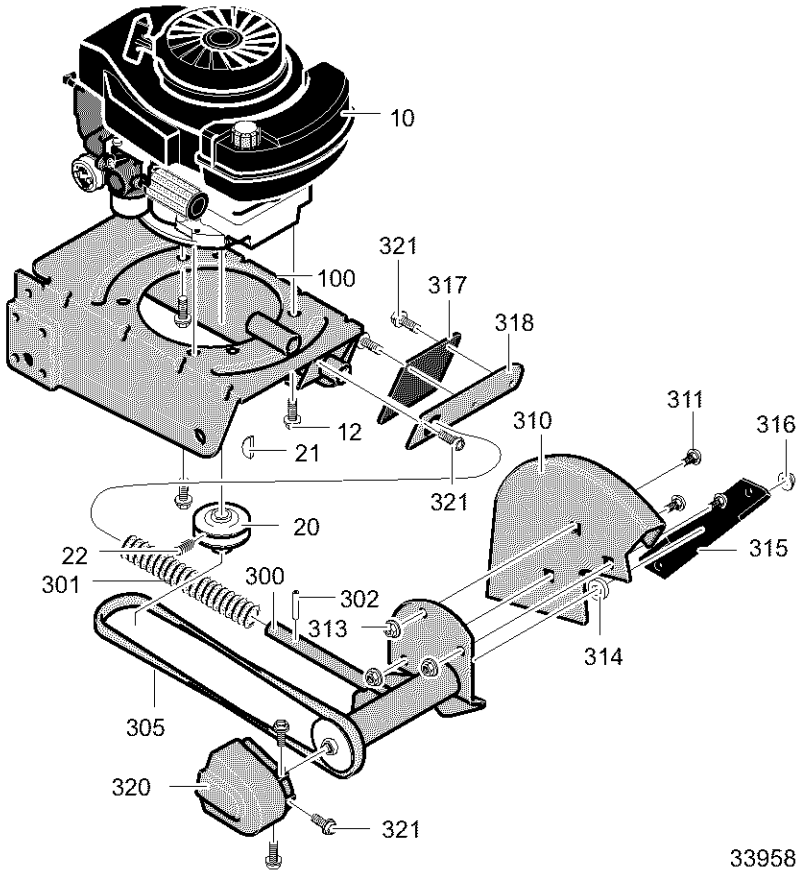

339589C

KEY NO.	DESCRIPTION	PART NO.	KEY NO.	DESCRIPTION	PART NO.
10	3.5 HP 143.003502 (See Engine pages)	Engine	311	Bolt, Carriage	57072
12	Screw	47792	313	Nut, 5/16-18	710205
20	Pulley, V3L	52052	314	Flat washer	22265
22	Key, Hi Pro #505	338490	315	Blade, Edger	740297
100	Frame, Edger	740121-833	316	Nut, 1/2-20	46023
300	Quill Assembly	339283	317	Deflector, Rubber	338582
301	Spring	51603	318	Plate, Rubber Flap	337792-833
302	Spring Pin	412281	320	Belt Guard	336631
305	Belt, V4L	32668	321	Screw, 10-16x.50	710271
310	Blade Guard	331076-833	—	Instruction Manual	F-001101M

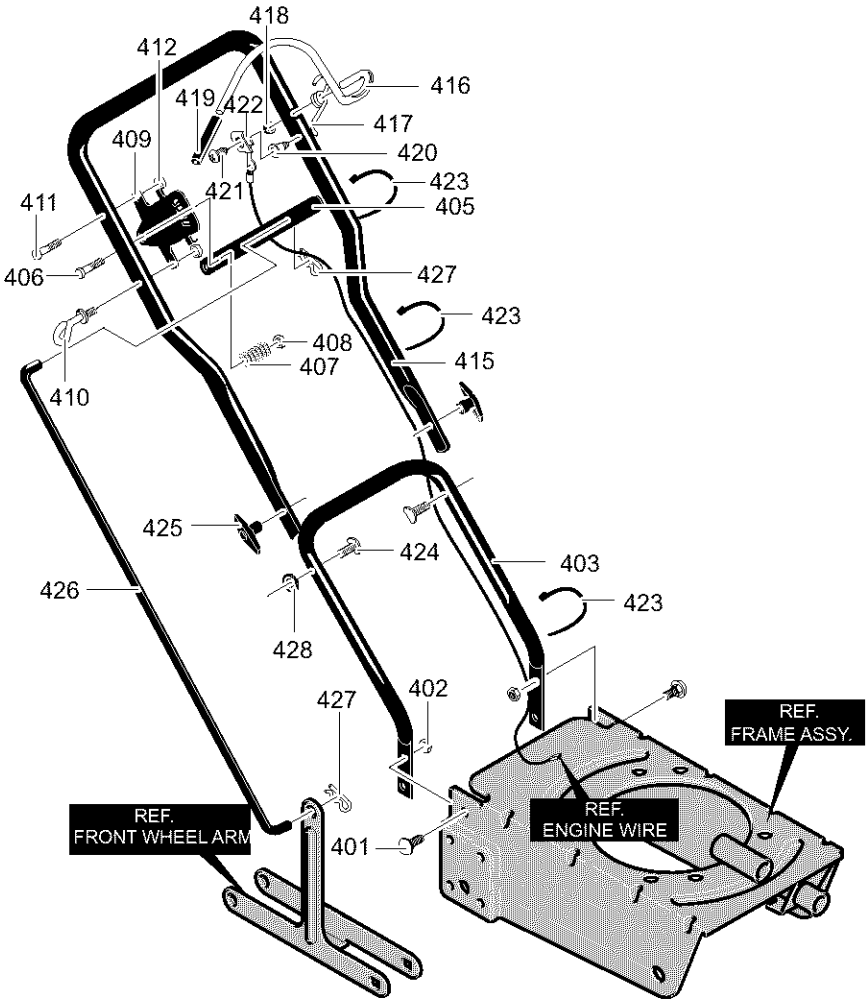

343712C

<b>KEY NO.</b>	<b>DESCRIPTION</b>	<b>PART NO.</b>
401	Bolt, 5/16–18x.75	711558
402	Nut, 5/16–18	45174
403	Lower Handle	740128–853
405	Handle, Depth	740130–853
406	Screw	180081
407	Spring, Compression	25644
408	Nut, 5/16–18	1498
409	Brkt, Adj. Quadrant	740143–853
410	Rope Guide	672510
411	Screw, 1/4–20x1.25	180024
412	Nut, 1/4–20	782585
415	Upper Handle	740142–853
416	Bail, Operator Control	337744
417	Torsion Spring	337775
418	Nut, Push On	314276
419	Cap, Operator Control	339489
420	Insulator, Oper Control	339229
421	Screw, #6x.50	57796
422	Clip, Grounding	340162
423	Cable Tie	712267
424	Bolt, 5/16–18x.75	315288
425	Wing Knob 5/16–18	671294
426	Rod, Control	740144–853
427	Hair Pin	36368
428	Washer, Exlk.	138485

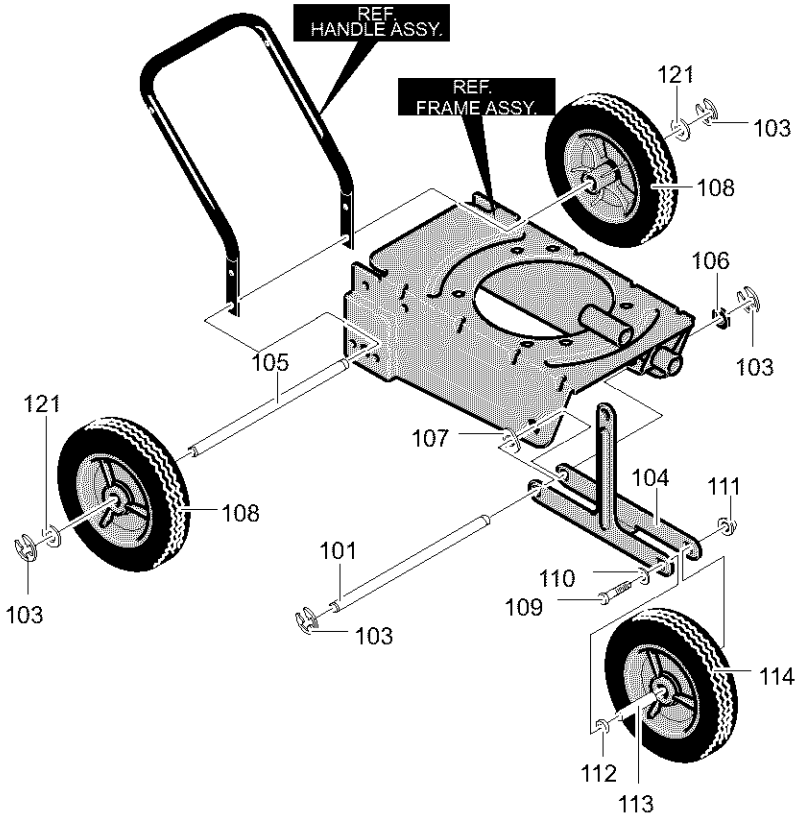

343716B

KEY NO.	DESCRIPTION	PART NO.	KEY NO.	DESCRIPTION	PART NO.
101	Rod, Axle Front	740091	109	Screw	180091
103	Ring, Ret E.	20864	110	Flat washer	120393
104	Arm, Front Wheel	740126-833	111	Nut, 5/16-18	710205
105	Rod, Axle R.	740095	112	Washer, Nylon	711008
106	Flat washer	417098	113	Spacer, Sleeve	740046
107	Spring Washer	710258	114	Tire & Rim	339079
108	Tire & Rim	339079	121	Flat washer	17x91



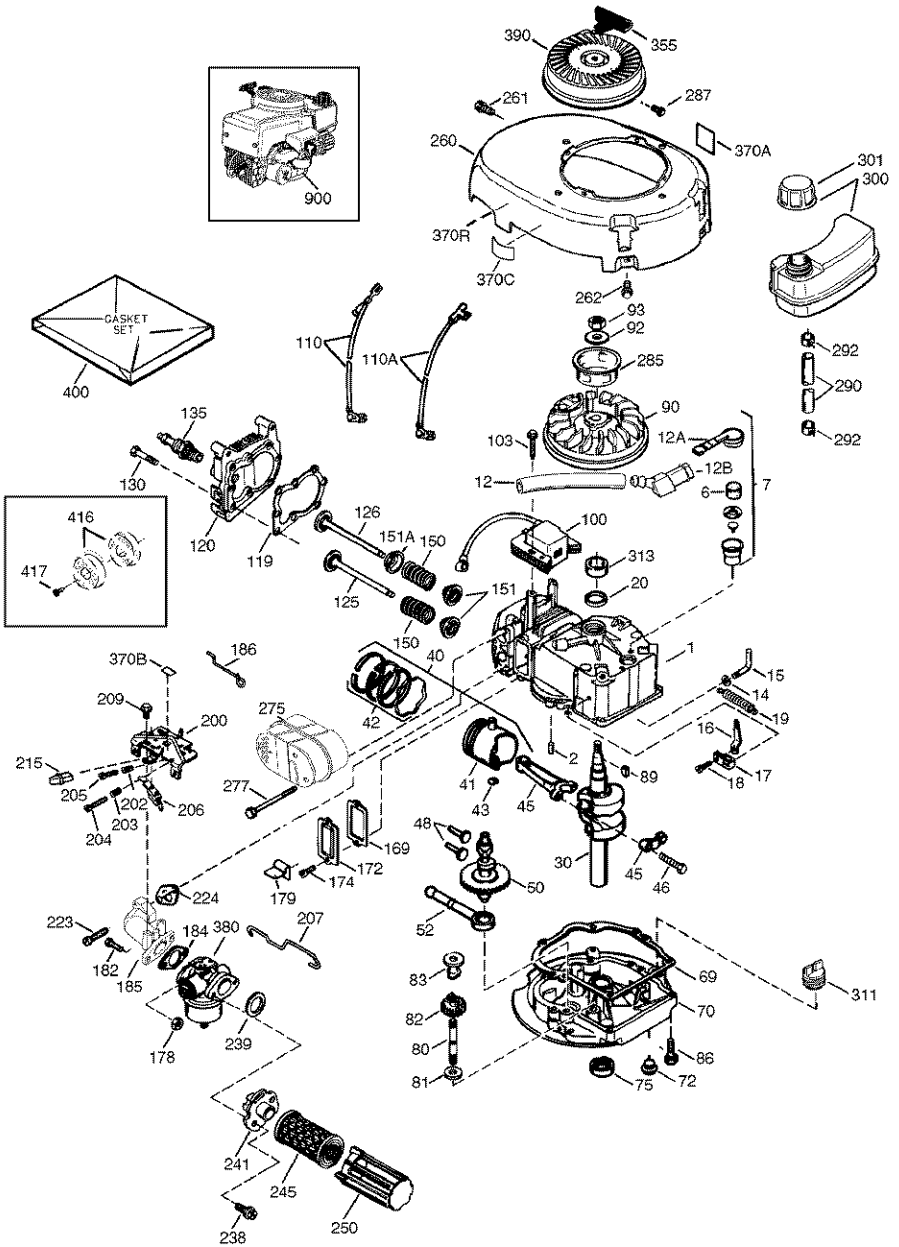

# CRAFTSMAN 143.003502

# REPAIR PARTS

KEY NO.	PART NO.	DESCRIPTION	KEY NO.	PART NO.	DESCRIPTION
	0	RPM High 3050 to 3350	45	36777	Connecting Rod Ass'y. (Incl. 46)
	0	RPM Low 2400 to 2700	46	32610A	Connecting Rod Bolt
	27625	Oil Fill Plug	48	27241	Valve Lifter
	29673	Oil Fill Plug Gasket	50	37032	Camshaft (NCR)
1	37280	Cylinder (Incl. 2,20 & 150)	52	29914	Oil Pump Ass'y.
2	26727	Dowel Pin	69	35261	Mounting Flange Gasket
6	33734	Breather Element	70	32612C	Mounting Flange (Incl. 72 thru 83)
7	36557	Breather Ass'y. (Incl. 6 & 12A)	72	36083	Oil Drain Plug
12	36775	Breather Tube	75	27897	Oil Seal
12A	36558	Breather Cover & Tube (Incl. 12B)	80	30574A	Governor Shaft
12B	36694	Breather Tube Elbow	81	30590A	Washer
14	28277	Washer	82	30591	Governor Gear Ass'y. (Incl. 81)
15	30589	Governor Rod (Incl. 14)	83	30588A	Governor Spool
16	34839A	Governor Lever	86	650488	Screw, 1/4-20 x 1-1/4"
17	31335	Governor Lever Clamp	89	610961	Flywheel Key
18	651018	Screw, Torx	90	611213	Flywheel
19	36281	Extension Spring	92	650815	Belleville Washer
20	32600	Oil Seal	93	650816	Flywheel Nut
30	36833	Crankshaft	100	34443B	Solid State Ignition
40	35544A	Piston, Pin & Ring Set (Std.)	103	651007	Screw, Torx T-15
40	35545A	Piston, Pin & Ring Set (.010" OS)	110	36230	Ground Wire
40	35546	Piston, Pin & Ring Set (.020" OS)	110A	36816	Ground Wire
41	35541	Piston & Pin Ass'y. (Std.) (Incl. 43)	119	37028	Cylinder Head Gasket
41	35542	Piston & Pin Ass'y. (.010" OS) (Incl. 43)	120	36825	Cylinder Head
41	35543	Piston & Pin Ass'y. (.020" OS) (Incl. 43)	125	37288	Exhaust Valve (Std.) (Incl. 151)
42	35547A	Ring Set (Std.)	126	37289	Intake Valve (Std.) (Incl. 151)
42	35548A	Ring Set (.010" OS)	130	6021A	Screw, 5/16-18 x 1-1/2"
42	35549	Ring Set (.020 OS)	135	35395	Resistor Spark Plug (RJ19LM)
43	20381	Piston Pin Retaining Ring	150	31672	Valve Spring

# CRAFTSMAN 143.003502

# REPAIR PARTS

151	31673	Valve Spring Cap	275	36790A	Muffler
151A	40017	Intake Valve Seal	277	650988	Screw, 1/4–20 x 2–5/16"
169	36783	Valve Cover Gasket	285	35000A	Starter Cup
172	36784	Valve Cover	287	650926	Screw, 8–32 x 21/64"
174	30200	Screw, 10–24 x 9/16"	290	34357	Fuel Line
178	29752	Nut & Lock Washer	292	26460	Fuel Line Clamp
179	30593	Retainer Clip	300	35586	Fuel Tank (Incl. 292 & 301)
182	6201	Screw, 1/4–28 x 7/8"	301	35355	Fuel Cap
184	26756	Carburetor To Intake Pipe Gasket	311	27625	Oil Fill Plug Ass'y
185	36785	Intake Pipe	313	34080	Spacer
186	34337	Governor Link	355	590701	Starter Handle (Black)
200	33205A	Control Bracket (Incl. 202 thru 206)	370A	36261	Lubrication Decal
202	36482	Compression Spring	370B	35169	Control Decal
203	31342	Compression Spring	370C	37318	Primer Decal 3 X)
204	651029	Screw, Torx T–10	370R	37317	Warning Decal
205	651019	Screw, Torx T–10	380	640262	Carburetor (Incl. 184)
206	610973	Terminal	390	590737	Rewind Starter (NOTE: This engine could have been built with 590694 starter).
207	34336	Throttle Link	400	37029A	Gasket Set (Incl. Items Marked PK in Notes) Incl. Part #'s 26756 (1), 28833 (1), 34338 (1), 35261 (1), 36783 (1), 36786 (1), 37028 (1), 36832 (1), 36996 (1)
209	30200	Screw, 10–24 x 9/16"	416	36085	Spark Arrestor Kit (Incl. 417) (Optional)
215	32410	Control Knob	417	650821	Screw, 10–32 x 1/2" (Optional)
223	650451	Screw, 1/4–20 x 1"	900	0	Replacement Engine NONE, order from 71–999
224	36786	Intake Pipe Gasket	900	0	Replacement S/B 750831, order from 71–999
238	650932	Screw, 10–32 x 49/64"			
239	34338	Air Cleaner Gasket			
241	35797	Air Cleaner Collar			
245	35066	Air Cleaner Filter			
250	35065	Air Cleaner Cover			
260	36834	Blower Housing			
261	30200	Screw, 10–24 x 9/16"			
262	650831	Screw, 1/4–20 x 1/2"			

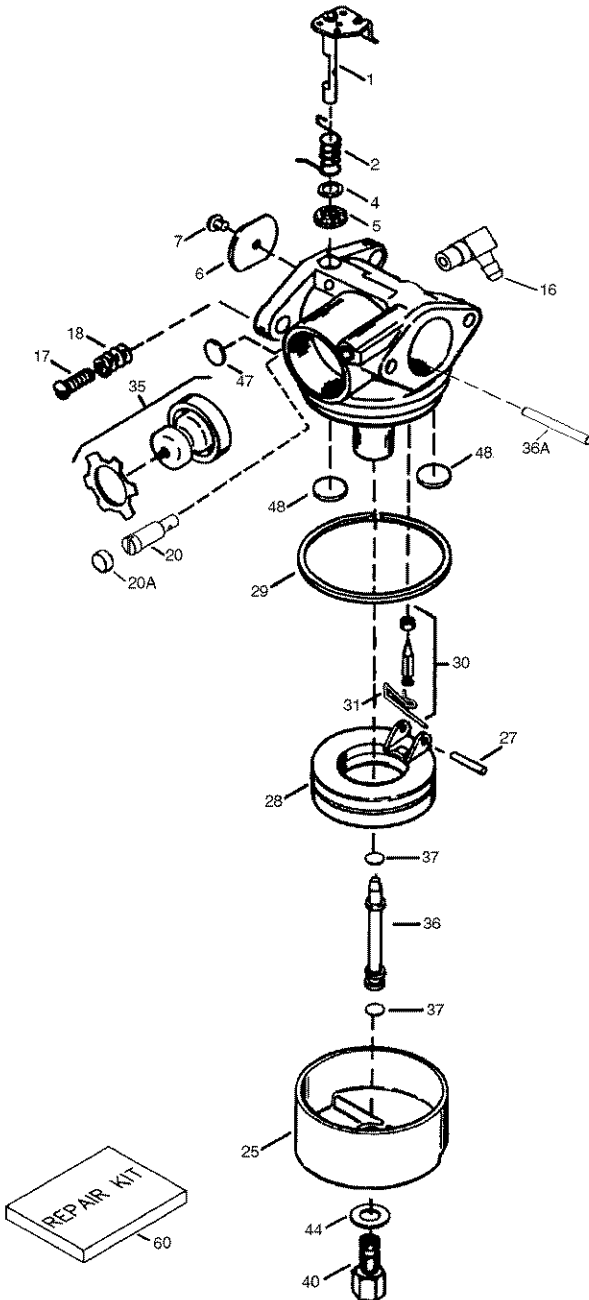

# CRAFTSMAN 143.003502

# REPAIR PARTS

KEY NO.	PART NO.	DESCRIPTION
0	640262	Carburetor (Incl. 184 of Engine Parts List)
1	631615	Throttle Shaft & Lever Assembly
2	631767	Throttle Return Spring
4	631184	Dust Seal Washer
5	631183	Dust Seal (Throttle)
6	640070	Throttle Shutter
7	650506	Shutter Screw
16	631807	Fuel Fitting
17	651025	Throttle Crack Screw/Idle Speed Screw
18	630766	Tension Spring
20	640018	Idle Restrictor Screw
20A	640200	Idle Restrictor Scrwe Cap (Black)
25	631867	Float Bowl
27	631024	Float Shaft
28	632019	Float
29	631028	Float Bowl "O" Ring
30	631021	Inlet Needle, Seat, & Clip (Incl. 31)
31	631022	Spring Clip
35	640259	Primer Bulb/Retainer Ring
36	640080	Main Nozzle Tube
36A	632766	Carburetor Tube
37	632547	"O" Ring, Main Nozzle Tube
40	640175	High Speed Bowl Nut
44	27110A	Bowl Nut Washer
47	630748	Welch Plug, Idle Mixture Well
48	631027	Welch Plug, Atmospheric Vent2
60	632760B	Repair kit (Incl. Items Marked PK in Notes)

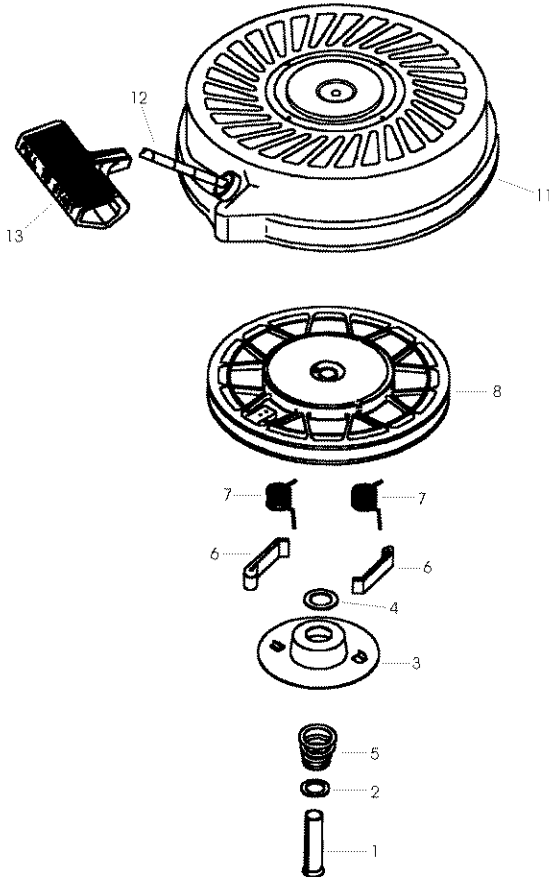

KEY NO.	PART NO.	DESCRIPTION
0	590694	Recoil Starter
1	590599A	Spring Pin (Incl. 4)
2	590600	Washer
3	590696	Retainer
4	590601	Washer
5	590697	Brake Spring
6	590698	Starter Dog
7	590699	Dog Spring
8	590700	Pulley & Rewind Spring Ass'y.
11	590695	Starter Housing Ass'y.
12	590535	Starter Rope ( .98" X 9/64" dia.)
13	590701	Starter Handle

For the repair or replacement parts you need delivered directly to your home  
Call 7am–7pm, 7days a week

**1-800-366-PART**

(1-800-366-7278)

Para ordenar piezas con entrega a domicilio – 1-800-659-7084

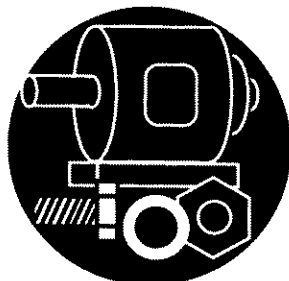

For in-house major brand repair service  
Call 24 hours a day, 7days a week

**1-800-4-REPAIR**

(1-800-473-7247)

Para pedir servicio de reparación a domicilio– 1-800-676-5811



For the location of a Sears Parts and Repair Center in your area

Call 24 hours a day, 7days a week

**1-800-488-1222**



For information on purchasing a Sears Maintenance agreement or to inquire about an existing Agreement

Call 9am–5pm, Monday–Saturday

**1-800-827-6655**



When requesting service or ordering parts, always provide the following information:

- Product Type
- Part Number
- Model Number
- Part Description

**SEARS**  
**REPAIR SERVICES**

*America's Repair Specialists*

Printed in U.S.A.

## Free Manuals Download Website

<http://myh66.com>

<http://usermanuals.us>

<http://www.somanuals.com>

<http://www.4manuals.cc>

<http://www.manual-lib.com>

<http://www.404manual.com>

<http://www.luxmanual.com>

<http://aubethermostatmanual.com>

Golf course search by state

<http://golfingnear.com>

Email search by domain

<http://emailbydomain.com>

Auto manuals search

<http://auto.somanuals.com>

TV manuals search

<http://tv.somanuals.com>