

Owner's Manual

CRAFTSMAN®

**15.5 HP
ELECTRIC START
42" MOWER
AUTOMATIC
LAWN TRACTOR**

EZ³

Model No.
917.270660

- Safety
- Assembly
- Operation
- Maintenance
- Repair Parts

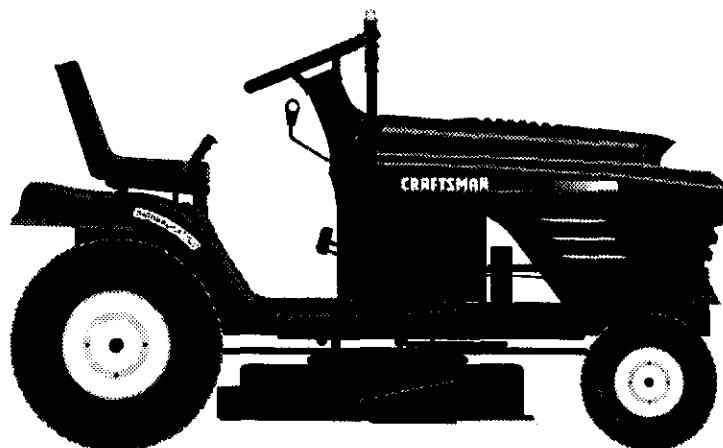

This product has a low emission engine which operates differently from previously built engines. Before you start the engine, read and understand this Owner's Manual.

CAUTION:

Read and follow all Safety Rules and Instructions before operating this equipment.

For answers to your questions about this product, Call:

1-800-659-5917
Sears Craftsman Help Line
5 am - 5 pm, Mon - Sat

Sears, Roebuck and Co., Hoffman Estates, IL 60179
Visit our Craftsman Website: www.sears.com/craftsman

TABLE OF CONTENTS

Warranty	2	Maintenance	18
Safety Rules	2	Service and Adjustments	22
Product Specifications	5	Storage	29
Assembly	8	Troubleshooting	30
Operation	11	Repair Parts	34
Maintenance Schedule	18	Parts Ordering	Back Cover

WARRANTY

LIMITED TWO YEAR WARRANTY ON CRAFTSMAN RIDING EQUIPMENT

For two (2) years from the date of purchase, if this Craftsman Riding Equipment is maintained, lubricated and tuned up according to the instructions in the owner's manual, Sears will repair or replace, free of charge, any parts found to be defective in material or workmanship.

This Warranty does not cover:

- Expendable items which become worn during normal use, such as blades, spark plugs, air cleaners, belts, etc.
- Tire replacement or repair caused by punctures from outside objects, such as nails, thorns, stumps, or glass.
- Repairs necessary because of operator abuse, negligence, improper storage or accident or the failure to maintain the equipment according to the instructions contained in the owner's manual.
- Riding equipment used for commercial or rental purposes.

LIMITED 90 DAY WARRANTY ON BATTERY

For ninety (90) days from date of purchase, if any battery included with this riding equipment proves defective in material or workmanship and our testing determines the battery will not hold a charge, Sears will replace the battery at no charge. In-home warranty service on your Craftsman riding equipment is available at no charge for 30 days from the date of purchase. Please contact your nearest service center. After 30 days from the date of purchase, warranty service is available by taking your Craftsman riding equipment to your nearest Sears Service Center. (In-home warranty service will still be available after 30 days from the date of purchase but a standard trip charge will apply). This warranty applies only while this product is in the United States. This Warranty gives you specific legal rights, and you may also have other rights which may vary from state to state.

Sears, Roebuck and Co., D/817 WA, Hoffman Estates, IL 60179

SAFETY RULES

IMPORTANT: This cutting machine is capable of amputating hands and feet and throwing objects. Failure to observe the following safety instructions could result in serious injury or death.

GENERAL OPERATION

- Read, understand, and follow all instructions in the manual and on the machine before starting.
- Only allow responsible adults, who are familiar with the instructions, to operate the machine.
- Clear the area of objects such as rocks, toys, wire, etc., which could be picked up and thrown by the blade.

- Be sure the area is clear of other people before mowing. Stop machine if anyone enters the area.
- Never carry passengers.
- Do not mow in reverse unless absolutely necessary. Always look down and behind before and while backing.
- Be aware of the mower discharge direction and do not point it at anyone. Do not operate the mower without either the entire grass catcher or the guard in place.
- Slow down before turning.
- Never leave a running machine unattended. Always turn off blades, set parking brake, stop engine, and remove keys before dismounting.

SAFETY RULES

- Turn off blades when not mowing.
- Stop engine before removing grass catcher or unclogging chute.
- Mow only in daylight or good artificial light.
- Do not operate the machine while under the influence of alcohol or drugs.
- Watch for traffic when operating near or crossing roadways.
- Use extra care when loading or unloading the machine into a trailer or truck.
- Data indicates that operators, age 60 years and above, are involved in a large percentage of riding mower-related injuries. These operators should evaluate their ability to operate the riding mower safely enough to protect themselves and others from serious injury.

SLOPE OPERATION

Slopes are a major factor related to loss-of-control and tipover accidents, which can result in severe injury or death. All slopes require extra caution. If you cannot back up the slope or if you feel uneasy on it, do not mow it.

DO:

- Mow up and down slopes, not across.
- Remove obstacles such as rocks, tree limbs, etc.
- Watch for holes, ruts, or bumps. Uneven terrain could overturn the machine. Tall grass can hide obstacles.
- Use slow speed. Choose a low gear so that you will not have to stop or shift while on the slope.
- Follow the manufacturer's recommendations for wheel weights or counterweights to improve stability.
- Use extra care with grass catchers or other attachments. These can change the stability of the machine.
- Keep all movement on the slopes slow and gradual. Do not make sudden changes in speed or direction.
- Avoid starting or stopping on a slope. If tires lose traction, disengage the blades and proceed slowly straight down the slope.

DO NOT:

- *Do not* turn on slopes unless necessary, and then, turn slowly and gradually downhill, if possible.
- *Do not* mow near drop-offs, ditches, or embankments. The mower could

suddenly turn over if a wheel is over the edge of a cliff or ditch, or if an edge caves in.

- *Do not* mow on wet grass. Reduced traction could cause sliding.
- *Do not* try to stabilize the machine by putting your foot on the ground.
- *Do not* use grass catcher on steep slopes.

CHILDREN

Tragic accidents can occur if the operator is not alert to the presence of children. Children are often attracted to the machine and the mowing activity. *Never* assume that children will remain where you last saw them.

- Keep children out of the mowing area and under the watchful care of another responsible adult.
- Be alert and turn machine off if children enter the area.
- Before and when backing, look behind and down for small children.
- Never carry children. They may fall off and be seriously injured or interfere with safe machine operation.
- Never allow children to operate the machine.
- Use extra care when approaching blind corners, shrubs, trees, or other objects that may obscure vision.

SERVICE

- Use extra care in handling gasoline and other fuels. They are flammable and vapors are explosive.
 - Use only an approved container.
 - Never remove gas cap or add fuel with the engine running. Allow engine to cool before refueling. Do not smoke.
 - Never refuel the machine indoors.
 - Never store the machine or fuel container inside where there is an open flame, such as a water heater.
- Never run a machine inside a closed area.
- Keep nuts and bolts, especially blade attachment bolts, tight and keep equipment in good condition.
- Never tamper with safety devices. Check their proper operation regularly.
- Keep machine free of grass, leaves, or other debris build-up. Clean oil or fuel spillage. Allow machine to cool before storing.

SAFETY RULES

- Stop and inspect the equipment if you strike an object. Repair, if necessary, before restarting.
- Never make adjustments or repairs with the engine running.
- Grass catcher components are subject to wear, damage, and deterioration, which could expose moving parts or allow objects to be thrown. Frequently check components and replace with manufacturer's recommended parts, when necessary.
- Mower blades are sharp and can cut. Wrap the blade(s) or wear gloves, and use extra caution when servicing them.
- Check brake operation frequently. Adjust and service as required.



- Be sure the area is clear of other people before mowing. Stop machine if anyone enters the area.
- Never carry passengers.
- Do not mow in reverse unless absolutely necessary. Always look down and behind before and while backing.
- Never carry children. They may fall off and be seriously injured or interfere with safe machine operation.
- Keep children out of the mowing area and under the watchful care of another responsible adult.
- Be alert and turn machine off if children enter the area.
- Before and when backing, look behind and *down* for small children.
- Mow up and down slopes (15° Max), not across.
- Remove obstacles such as rocks, tree limbs, etc.
- Watch for holes, ruts, or bumps. Uneven terrain could overturn the machine. *Tall grass can hide obstacles.*
- Use slow speed. Choose a low gear so that you will not have to stop or shift while on the slope.
- Avoid starting or stopping on a slope. If tires lose traction, disengage the blades and proceed slowly *straight* down the slope.
- *Do not* turn on slopes unless necessary, and then, turn slowly and gradually downhill, if possible.

⚠ CAUTION: Look for this symbol to point out important safety precautions. It means **CAUTION!!! BECOME AWARE!!! YOUR SAFETY IS INVOLVED.**

⚠ CAUTION: In order to prevent accidental starting when setting up, transporting, adjusting or making repairs always disconnect spark plug wire and place wire where it cannot contact spark plug.

⚠ WARNING: The engine exhaust from this product contains chemicals known to the State of California to cause cancer, birth defects, or other reproductive harm.

PRODUCT SPECIFICATIONS

GASOLINE CAPACITY AND TYPE:	1.25 GALLONS UNLEADED REGULAR
OIL TYPE (API-SF/SG/SH):	SAE 30 (above 32°F) SAE 5W-30 (below 32°F)
OIL CAPACITY:	3.0 PINTS
SPARK PLUG: (GAP: .030")	Champion RC12YC
VALVE CLEARANCE:	INTAKE: .003"-.005" EXHAUST: .005"-.007"
GROUND SPEED (MPH):	FORWARD: 0 - 5.7 REVERSE: 0 - 2.7
TIRE PRESSURE:	FRONT: 14 PSI REAR: 12 PSI
CHARGING SYSTEM:	3 AMPS BATTERY 5 AMPS HEADLIGHTS
BATTERY:	AMP/HR: 25 MIN. CCA: 190 CASE SIZE: U1R
BLADE BOLT TORQUE:	27-35 FT. LBS.

CONGRATULATIONS on your purchase of a Craftsman Tractor. It has been designed, engineered and manufactured to give you the best possible dependability and performance.

Should you experience any problem you cannot easily remedy, please contact your nearest Sears Authorized Service Center. We have competent, well-trained technicians and the proper tools to service or repair this tractor.

Please read and retain this manual. The instructions will enable you to assemble and maintain your tractor properly. Always observe the "SAFETY RULES".

MAINTENANCE AGREEMENT

A Sears Maintenance Agreement is available on this product. Contact your nearest Sears store for details.

CUSTOMER RESPONSIBILITIES

- Read and observe the safety rules.
- Follow a regular schedule in maintaining, caring for and using your tractor.
- Follow the instructions under "Maintenance" and "Storage" sections of this owner's manual.

⚠ WARNING: This tractor is equipped with an internal combustion engine and should not be used on or near any unimproved forest-covered, brush-covered or grass-covered land unless the engine's exhaust system is equipped with a spark arrester meeting applicable local or state laws (if any). If a spark arrester is used, it should be maintained in effective working order by the operator.

In the state of California the above is required by law (Section 4442 of the California Public Resources Code). Other states may have similar laws. Federal laws apply on federal lands. A spark arrester for the muffler is available through your nearest Sears Authorized Service Center (See REPAIR PARTS section of this manual).

CONTENTS OF HARDWARE PACK

PARTS BAG CONTENTS SHOWN FULL SIZE

(1) Large Flat Washer

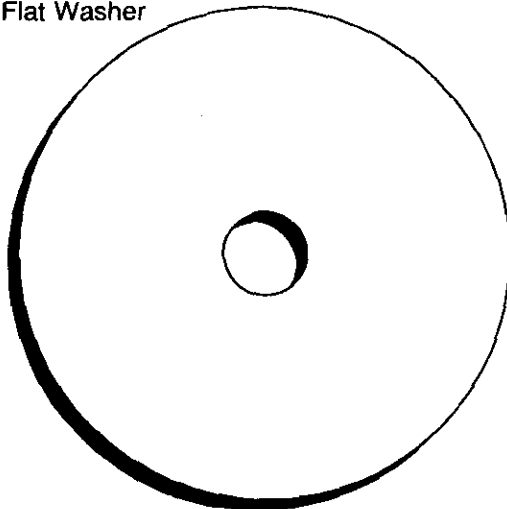

(1) Large Flat Washer

(1) Hex Bolt
3/8-16 x 1

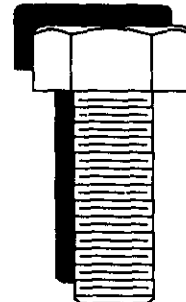

(1) Lockwasher 3/8



(1) Hex Bolt 5/16-18 x 1-1/4



(1) Locknut 5/16-18

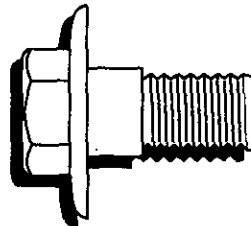

(1) Shoulder Bolt 5/16-18

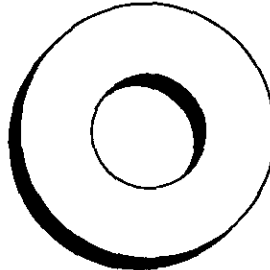

(1) Washer 17/32 x 1-3/16 x 12 Gauge

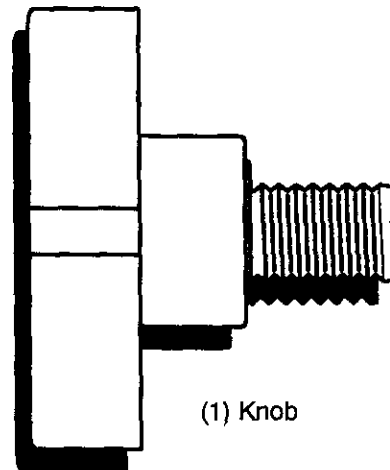

(1) Knob

CONTENTS OF HARDWARE PACK

PARTS BAG CONTENTS SHOWN FULL SIZE



(2) Screws #10 x 5/8



(2) Lock Washers #10

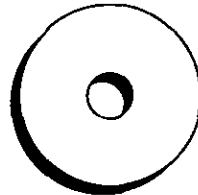

(2) Washers 3/16 x 3/4 x 16 Gauge

(2) Weld Nuts #10

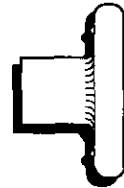

Parts packet separately in carton

Parts Bag contents not shown full size



Seat

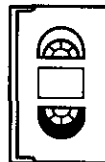

Video
Cassette

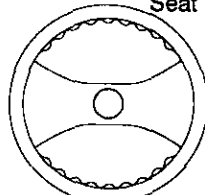

Steering
Wheel

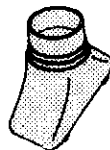

Steering
Boot



Mulcher
Plate



Manual



Parts Bag

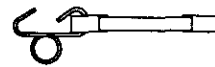

(2) Latch Hook
Assemblies

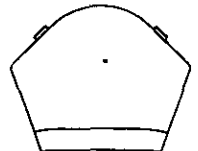

Steering
Wheel
Insert

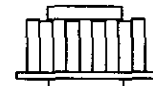

Steering Wheel
Adapter



(2) Keys

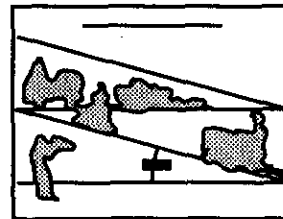

Slope Sheet

Steering
Extension
Shaft



ASSEMBLY

Your new tractor has been assembled at the factory with exception of those parts left unassembled for shipping purposes. To ensure safe and proper operation of your tractor all parts and hardware you assemble must be tightened securely. Use the correct tools as necessary to insure proper tightness. Review the video cassette before you begin.

TOOLS REQUIRED FOR ASSEMBLY

A socket wrench set will make assembly easier. Standard wrench sizes you need are listed below.

- | | |
|---------------------------|-------------------------|
| (1) 9/16" wrench | (2) 1/2" wrench |
| (1) Pliers | (1) Utility knife |
| (1) Phillips Screw-driver | (1) Tire pressure gauge |

When right or left hand is mentioned in this manual, it means, from your point of view, when you are in the operating position (seated behind the steering wheel).

TO REMOVE TRACTOR FROM CARTON UNPACK CARTON

- Remove all accessible loose parts and parts boxes from shipping carton.
- Cut, from top to bottom, along lines on all four corners of shipping carton, and lay panels flat.
- Check for any additional loose parts or boxes and remove.

BEFORE ROLLING TRACTOR OFF SKID

ATTACH STEERING WHEEL

ASSEMBLE EXTENSION SHAFT AND BOOT

- Slide extension shaft onto lower steering shaft. Align mounting holes in extension and lower shafts and install 5/16 hex bolt and locknut. Tighten securely.

IMPORTANT: Tighten bolt and nut securely to 18-22 ft. lbs. torque.

- Place tabs of steering boot over tab slots in dash and push down to secure.

INSTALL STEERING WHEEL

- Position front wheels of the tractor so they are pointing straight forward.
- Slide steering wheel adapter onto steering shaft extension.
- Position steering wheel so cross bars are horizontal (left to right) and slide inside boot and onto adapter.
- Assemble large flat washer, 3/8 lock washer, 3/8 hex bolt and tighten securely.

- Snap steering wheel insert into center of steering wheel.
- Remove protective materials from tractor hood and grill.

IMPORTANT: Check for and remove any staples in skid that may puncture tires where tractor is to roll off skid.

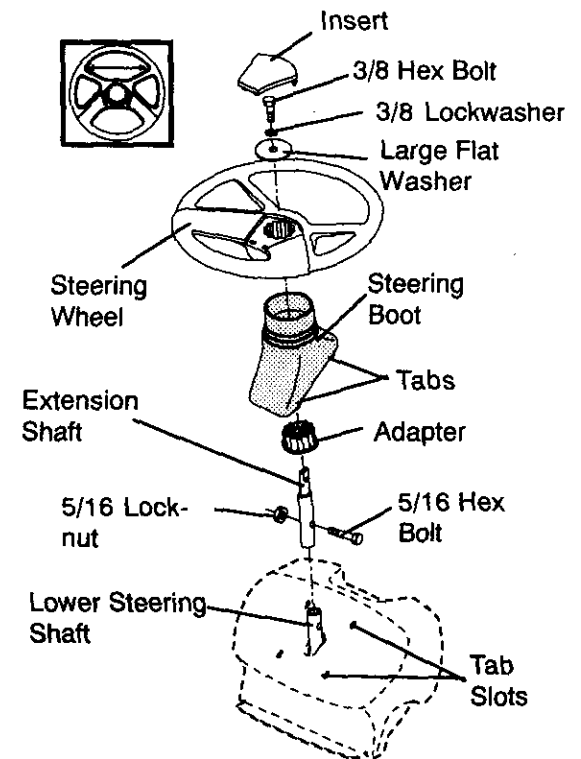

HOW TO SET UP YOUR TRACTOR CHECK BATTERY

- Lift seat pan to raised position and open battery box door.
- If this battery is put into service after month and year indicated on label (label located between terminals) charge battery for minimum of one hour at 6-10 amps. (See "BATTERY" in MAINTENANCE section of this manual for charging instructions.)

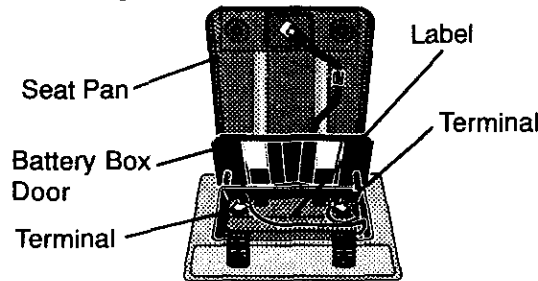

INSTALL SEAT

Adjust seat before tightening adjustment knob.

- Remove cardboard packing on seat pan.
- Place seat on seat pan and assemble shoulder bolt. Tighten shoulder bolt securely.
- Assemble adjustment knob and flat washer loosely. Do not tighten.
- Lower seat into operating position and sit on seat.
- Slide seat until a comfortable position is reached which allows you to press clutch/brake pedal all the way down.
- Get off seat without moving its adjusted position.
- Raise seat and tighten adjustment knob securely.

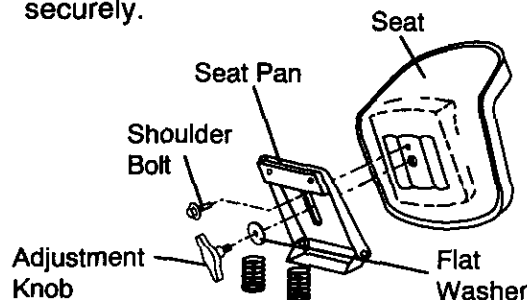

TO ROLL TRACTOR OFF SKID (See Operation section for location and function of controls)

- Press lift lever plunger and raise attachment lift lever to its highest position.
- Release parking brake by depressing clutch/brake pedal.

- Place freewheel control in freewheeling position to disengage transmission (See "TO TRANSPORT" in the Operation section of this manual).
- Roll tractor forward off skid.
- Remove banding holding discharge guard up against tractor.

TO DRIVE TRACTOR OFF SKID

⚠ WARNING: Before starting, read, understand and follow all instructions in the Operation section of this manual. Be sure tractor is in a well-ventilated area. Be sure the area in front of tractor is clear of other people and objects.

- Be sure all the above assembly steps have been completed.
 - Check engine oil level and fill fuel tank with gasoline.
 - Place freewheel control in "transmission engaged" position.
 - Sit on seat in operating position, depress clutch/brake pedal and set the parking brake.
 - Place motion control lever in neutral (N) position.
 - Press lift lever plunger and raise attachment lift lever to its highest position.
 - Start the engine. After engine has started, move throttle control to idle position.
 - Release parking brake.
 - Slowly move the motion control lever forward and slowly drive tractor off skid.
 - Apply brake to stop tractor, set parking brake and place motion control lever in neutral position.
 - Turn ignition key to "OFF" position.
- Continue with the instructions that follow.

CHECK TIRE PRESSURE

The tires on your tractor were overinflated at the factory for shipping purposes. Correct tire pressure is important for best cutting performance.

- Reduce tire pressure to PSI shown in "PRODUCT SPECIFICATIONS" section of this manual.

CHECK DECK LEVELNESS

For best cutting results, mower housing should be properly leveled. See "TO LEVEL MOWER HOUSING" in the Service and Adjustments section of this manual.

CHECK FOR PROPER POSITION OF ALL BELTS

See the figures that are shown for replacing motion and mower blade drive belts in the Service and Adjustments section of this manual. Verify that the belts are routed correctly.

CHECK BRAKE SYSTEM

After you learn how to operate your tractor, check to see that the brake is properly adjusted. See "TO ADJUST BRAKE" in the Service and Adjustments section of this manual.

INSTALL MULCHER PLATE

- Install two latch hooks to mulcher plate using screw, washer, lock washer, and weld nut as shown.

NOTE: Pre-assemble weld nut to latch hook by inserting weld nut from the top with hook pointing down.

- Tighten hardware securely.
- Raise and hold deflector shield in upright position.
- Place front of mulcher plate over front of mower deck opening and slide into place, as shown.
- Hook front latch into hole on front of mower deck.
- Hook rear latch into hole on back of mower deck.

⚠ CAUTION: Do not remove discharge guard from mower. Raise and hold guard when attaching mulcher plate and allow it to rest on plate while in operation.

TO CONVERT TO BAGGING OR DISCHARGING

Simply remove mulcher plate and store in a safe place. Your mower is now ready for discharging or installation of optional grass catcher accessory.

NOTE: It is not necessary to change blades. The mulcher blades are designed for discharging and bagging also.

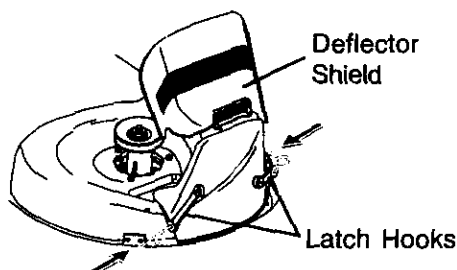
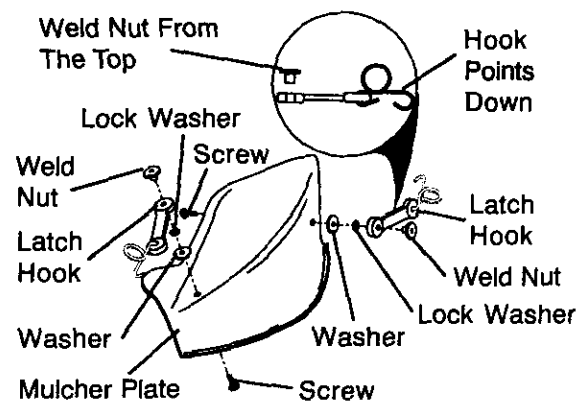

✓CHECKLIST

Before you operate and enjoy your new tractor, we wish to assure that you receive the best performance and satisfaction from this quality product.

Please review the following checklist:

- ✓ All assembly instructions have been completed.
 - ✓ No remaining loose parts in carton.
 - ✓ Battery is properly prepared and charged. (Minimum 1 hour at 6 amps).
 - ✓ Seat is adjusted comfortably and tightened securely.
 - ✓ All tires are properly inflated. (For shipping purposes, the tires were overinflated at the factory).
 - ✓ Be sure mower deck is properly leveled side-to-side/front-to-rear for best cutting results. (Tires must be properly inflated for leveling).
 - ✓ Check mower and drive belts. Be sure they are routed properly around pulleys and inside all belt keepers.
 - ✓ Check wiring. See that all connections are still secure and wires are properly clamped.
 - ✓ Before driving tractor, be sure free-wheel control is in drive position.
- While learning how to use your tractor, pay extra attention to the following important items:
- ✓ Engine oil is at proper level.
 - ✓ Fuel tank is filled with fresh, clean, regular unleaded gasoline.
 - ✓ Become familiar with all controls - their location and function. Operate them before you start the engine.
 - ✓ Be sure brake system is in safe operating condition.
 - ✓ It is important to purge the transmission before operating your tractor for the first time. Follow proper starting and transmission purging instructions (See "TO START ENGINE" and "PURGE TRANSMISSION" in the Operation section of this manual).

OPERATION

These symbols may appear on your tractor or in literature supplied with the product. Learn and understand their meaning.



BATTERY



CAUTION OR WARNING



REVERSE



FORWARD



FAST



SLOW



ENGINE ON



ENGINE OFF



OIL PRESSURE



LIGHTS ON



OVER TEMP LIGHT



MOWER LIFT



FUEL



CHOKE



MOWER HEIGHT



PARKING BRAKE LOCKED



UNLOCKED



MOWER LIFT



ATTACHMENT CLUTCH ENGAGED



REVERSE



NEUTRAL



HIGH



LOW



PARKING BRAKE



IGNITION



ATTACHMENT CLUTCH DISENGAGED



KEEP AREA CLEAR



SLOPE HAZARDS



(SEE SAFETY RULES SECTION)



DANGER, KEEP HANDS AND FEET AWAY

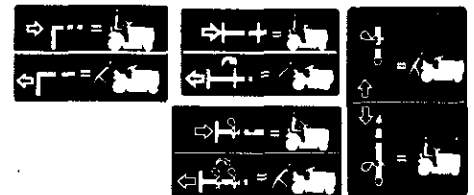

FREE WHEEL (Automatic Models only)

KNOW YOUR TRACTOR

READ THIS OWNER'S MANUAL AND SAFETY RULES BEFORE OPERATING YOUR TRACTOR

Compare the illustrations with your tractor to familiarize yourself with the locations of various controls and adjustments. Save this manual for future reference.

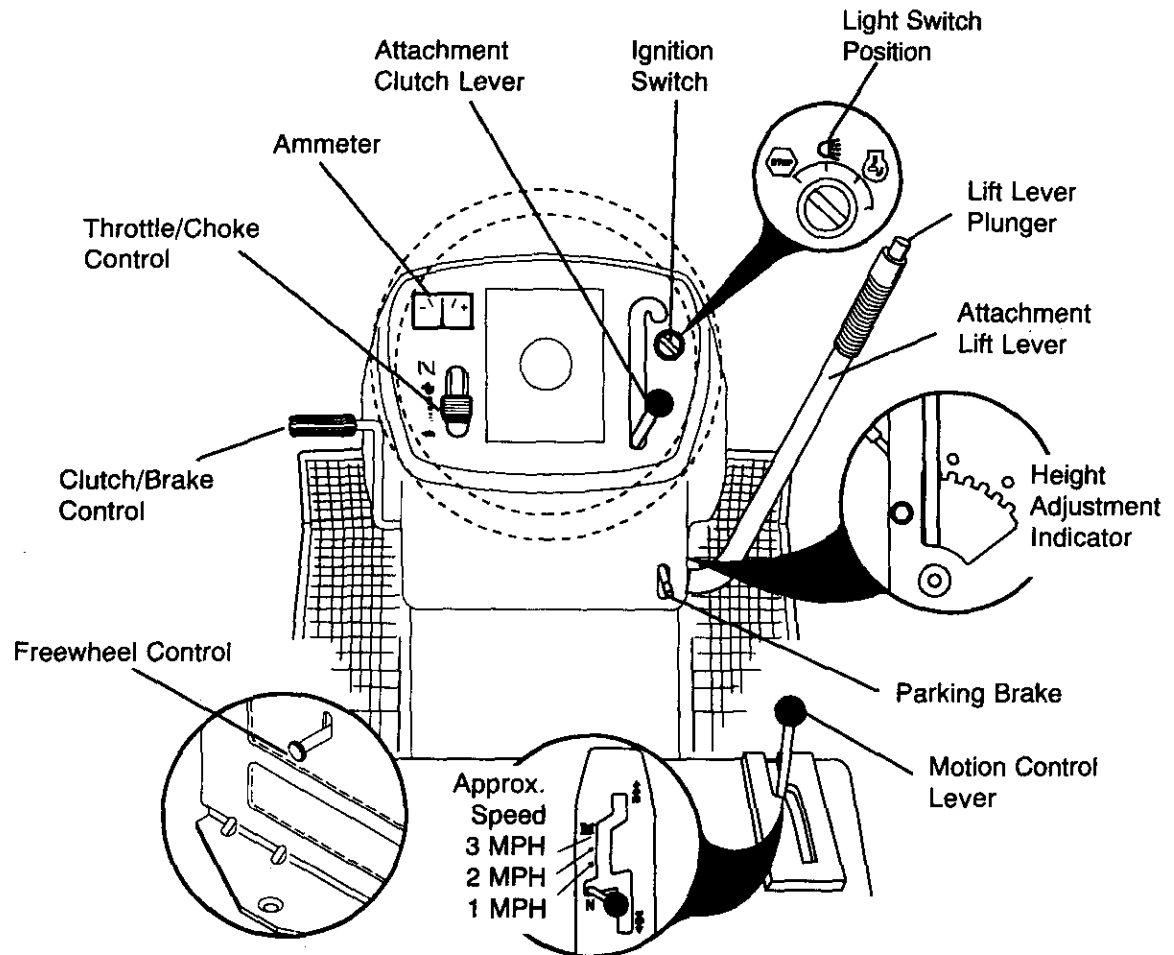

Our tractors conform to the safety standards of the American National Standards Institute.

ATTACHMENT CLUTCH LEVER: Used to engage the mower blades, or other attachments mounted to your tractor.

LIGHT SWITCH: Turns the headlights on and off.

THROTTLE/CHOKE CONTROL: Used to control engine speed.

CLUTCH/BRAKE PEDAL: Used for declutching and braking the tractor and starting the engine.

FREEWHEEL CONTROL: Disengages transmission for pushing or slowly towing the tractor with the engine off.

MOTION CONTROL LEVER: Selects the speed and direction of the tractor.

ATTACHMENT LIFT LEVER: Used to raise and lower the mower deck or other attachments mounted to your tractor.

LIFT LEVER PLUNGER: Used to release attachment lift lever when changing its position.

IGNITION SWITCH: Used for starting and stopping the engine.

AMMETER: Indicates battery charging (+) or discharging (-).

PARKING BRAKE: Locks clutch/brake into the brake position.



The operation of any tractor can result in foreign objects thrown into the eyes, which can result in severe eye damage. Always wear safety glasses or eye shields while operating your tractor or performing any adjustments or repairs. We recommend a wide vision safety mask over spectacles, or standard safety glasses.

HOW TO USE YOUR TRACTOR

TO SET PARKING BRAKE

Your tractor is equipped with an operator presence sensing switch. When engine is running, any attempt by the operator to leave the seat without first setting the parking brake will shut off the engine.

- Depress clutch/brake pedal into full "BRAKE" position and hold.
- Place parking brake lever in "ENGAGED" position and release pressure from clutch/brake pedal. Pedal should remain in "BRAKE" position. Make sure parking brake will hold tractor secure.

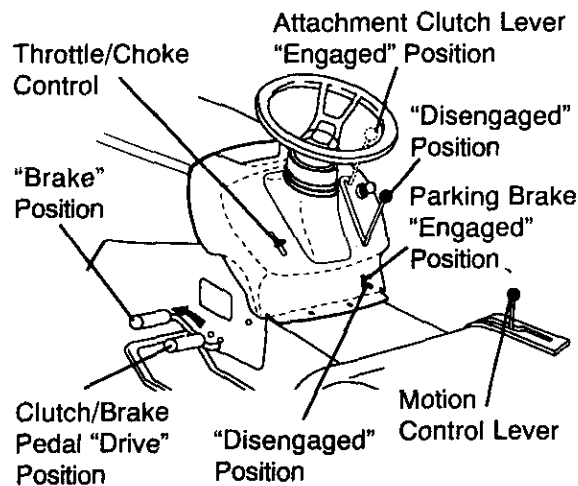

STOPPING

MOWER BLADES -

- To stop mower blades, move attachment clutch Lever to "DISENGAGED" position.

GROUND DRIVE -

- To stop ground drive, depress clutch/brake pedal into full "BRAKE" position.
- Move motion control lever to neutral (N) position.

IMPORTANT: The motion control lever does not return to neutral (N) position when the clutch/brake pedal is depressed.

ENGINE -

- Move throttle control to slow position.

NOTE: Failure to move throttle control to slow position and allowing engine to idle before stopping may cause engine to "backfire".

- Turn ignition key to "OFF" position and remove key. Always remove key when leaving tractor to prevent unauthorized use.

- Never use choke to stop engine.

IMPORTANT: Leaving the ignition switch in any position other than "OFF" will cause the battery to be discharged, (dead).

NOTE: Under certain conditions when tractor is standing idle with the engine running, hot engine exhaust gases may cause "browning" of grass. To eliminate this possibility, always stop engine when stopping tractor on grass areas.

CAUTION: Always stop tractor completely, as described above, before leaving the operator's position, to empty grass catcher, etc.

TO USE THROTTLE CONTROL

Always operate engine at full throttle.

- Operating engine at less than full throttle reduces the battery charging rate.
- Full throttle offers the best bagging and mower performance.

TO MOVE FORWARD AND BACKWARD

The direction and speed of movement is controlled by the motion control lever.

- Start tractor with motion control lever in neutral (N) position.
- Release parking brake and clutch/brake pedal.
- Slowly move motion control lever to desired position.

TO ADJUST MOWER CUTTING HEIGHT

The position of the attachment lift lever determines the cutting height.

- Grasp lift lever.
- Press plunger with thumb and move lever to desired position.

The cutting height range is approximately 1-1/2 to 4". The heights are measured from the ground to the blade tip with the engine not running. These heights are approximate and may vary depending upon soil conditions, height of grass and types of grass being mowed.

- The average lawn should be cut to approximately 2-1/2 inches during the cool season and to over 3 inches dur-

ing hot months. For healthier and better looking lawns, mow often and after moderate growth.

- For best cutting performance, grass over 6 inches in height should be mowed twice. Make the first cut relatively high; the second to desired height.

TO OPERATE MOWER

Your tractor is equipped with an operator presence sensing switch. Any attempt by the operator to leave the seat with the engine running and the attachment clutch engaged will shut off the engine.

- Select desired height of cut.
- Start mower blades by engaging attachment clutch control.
- TO STOP MOWER BLADES - disengage attachment clutch control.

CAUTION: Do not operate the mower without either the entire grass catcher, on mowers so equipped, or the discharge guard in place.

TO OPERATE ON HILLS

CAUTION: Do not drive up or down hills with slopes greater than 15° and do not drive across any slope. Use the slope guide provided at the back of this manual.

- Choose the slowest speed before starting up or down hills.
- Avoid stopping or changing speed on hills.
- If slowing is necessary, move throttle control lever to slower position.
- If stopping is absolutely necessary, push clutch/brake pedal quickly to brake position and engage parking brake.
- Move motion control lever to neutral (N) position.

IMPORTANT: The motion control lever does not return to neutral (N) position when the clutch/brake pedal is depressed.

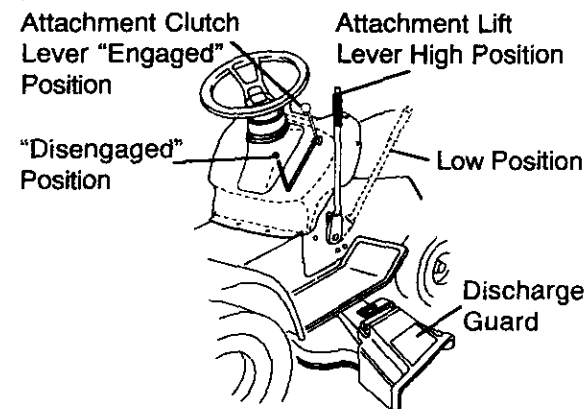

- To restart movement, slowly release parking brake and clutch/brake pedal.
- Slowly move motion control lever to slowest setting.
- Make all turns slowly.

TO TRANSPORT

When pushing or towing your tractor, be sure to disengage transmission by placing freewheel control in freewheeling position. Free wheel control is located at the rear drawbar of tractor.

- Raise attachment lift to highest position with attachment lift control.
- Pull freewheel control out and down into the slot and release so it is held in the disengaged position.
- Do not push or tow tractor at more than two (2) MPH.
- To reengage transmission, reverse above procedure.

NOTE: To protect hood from damage when transporting your tractor on a truck or a trailer, be sure hood is closed and secured to tractor. Use an appropriate means of tying hood to tractor (rope, cord, etc.).

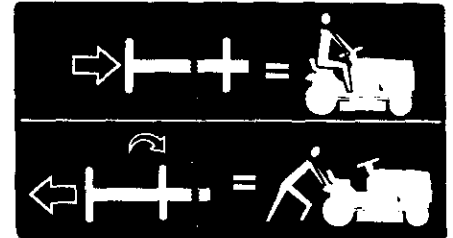

TOWING CARTS AND OTHER ATTACHMENTS

Tow only the attachments that are recommended by and comply with specifications of the manufacturer of your tractor. Use common sense when towing. Too heavy of a load, while on a slope, is dangerous. Tires can lose traction with the ground and cause you to lose control of your tractor.

BEFORE STARTING THE ENGINE

CHECK ENGINE OIL LEVEL

- The engine in your tractor has been shipped, from the factory, already filled with summer weight oil.
- Check engine oil with tractor on level ground.
- Remove oil fill cap/dipstick and wipe clean, reinsert the dipstick and screw cap tight, wait for a few seconds, remove and read oil level. If necessary, add oil until "FULL" mark on dipstick is reached. Do not overfill.

- For cold weather operation you should change oil for easier starting (See "OIL VISCOSITY CHART" in the Maintenance section of this manual).
- To change engine oil, see the Maintenance section in this manual.

ADD GASOLINE

- Fill fuel tank. Use fresh, clean, regular unleaded gasoline with a minimum of 87 octane. (Use of leaded gasoline will increase carbon and lead oxide deposits and reduce valve life). Do not mix oil with gasoline. Purchase fuel in quantities that can be used within 30 days to assure fuel freshness.

IMPORTANT: When operating in temperatures below 32°F(0°C), use fresh, clean winter grade gasoline to help insure good cold weather starting.

⚠ WARNING: Experience indicates that alcohol blended fuels (called gasohol or using ethanol or methanol) can attract moisture which leads to separation and formation of acids during storage. Acidic gas can damage the fuel system of an engine while in storage. To avoid engine problems, the fuel system should be emptied before storage of 30 days or longer. Drain the gas tank, start the engine and let it run until the fuel lines and carburetor are empty. Use fresh fuel next season. See Storage Instructions for additional information. Never use engine or carburetor cleaner products in the fuel tank or permanent damage may occur.

⚠ CAUTION: Fill to bottom of gas tank filler neck. Do not overfill. Wipe off any spilled oil or fuel. Do not store, spill or use gasoline near an open flame.

TO START ENGINE

When starting the engine for the first time or if the engine has run out of fuel, it will take extra cranking time to move fuel from the tank to the engine.

- Be sure freewheel control is in the transmission engaged position.
- Sit on seat in operating position, depress clutch/brake pedal and set parking brake.
- Place motion control lever in neutral (N) position.
- Move attachment clutch to "DISENGAGED" position.
- Move throttle control to choke position.

NOTE: Before starting, read the warm and cold starting procedures below.

- Insert key into ignition and turn key clockwise to "START" position and release key as soon as engine starts. Do not run starter continuously for more than fifteen seconds per minute. If the engine does not start after several attempts, move throttle control to fast position, wait a few minutes and try again. If engine still does not start, move the throttle control back to the choke position and retry.

WARM WEATHER STARTING (50° F and above)

- When engine starts, move the throttle control to the fast position.
- The attachments and ground drive can now be used. If the engine does not accept the load, restart the engine and allow it to warm up for one minute using the choke as described above.

COLD WEATHER STARTING (50° F and below)

- When engine starts, allow engine to run with the throttle control in the choke position until the engine runs roughly, then move throttle control to fast position. This may require an engine warm-up period from several seconds to several minutes, depending on the temperature.

AUTOMATIC TRANSMISSION WARM UP

- Before driving the unit in cold weather, the transmission should be warmed up as follows:
 - Be sure the tractor is on level ground.
 - Place the motion control lever in neutral. Release the parking brake and let the clutch/brake slowly return to operating position.
 - Allow one minute for transmission to warm up. This can be done during the engine warm up period.
 - The attachments can also be used during the engine warm-up period after the transmission has been warmed up.

NOTE: At a high altitude (above 3000 feet) or in cold temperatures (below 32 F) the carburetor fuel mixture may need to be adjusted for best engine performance. See "TO ADJUST CARBURETOR" in the Service and Adjustments section of this manual.

PURGE TRANSMISSION

⚠ CAUTION: Never engage or disengage freewheel lever while the engine is running.

To ensure proper operation and performance, it is recommended that the transmission be purged before operating tractor for the first time. This procedure will remove any trapped air inside the transmission which may have developed during shipping of your tractor.

IMPORTANT: Should your transmission require removal for service or replacement, it should be purged after reinstallation before operating the tractor.

- Place tractor safely on level surface with engine off and parking brake set.
- Disengage transmission by placing freewheel control in freewheeling position (See "TO TRANSPORT" in this section of manual).
- Sitting in the tractor seat, start engine. After the engine is running, move throttle control to slow position. With motion control lever in neutral (N) position, slowly disengage clutch/brake pedal.
- Move motion control lever to full forward position and hold for five (5) seconds. Move lever to full reverse position and hold for five (5) seconds. Repeat this procedure three (3) times.

NOTE: During this procedure there will be no movement of drive wheels. The air is being removed from hydraulic drive system.

- Move motion control lever to neutral (N) position. Shut off engine and set parking brake.
- Engage transmission by placing freewheel control in driving position (See "TO TRANSPORT" in this section of manual).
- Sitting in the tractor seat, start engine. After the engine is running, move throttle control to half (1/2) speed. With motion control lever in neutral (N) position, slowly disengage clutch/brake pedal.
- Slowly move motion control lever forward; after the tractor moves approximately five (5) feet, slowly move motion control lever to reverse position. After the tractor moves approximately five (5) feet return the motion control lever to the neutral (N) position. Repeat this

procedure with the motion control lever three (3) times.

- Your tractor is now purged and ready for normal operation.

MOWING TIPS

- Tire chains cannot be used when the mower housing is attached to tractor.
- Mower should be properly leveled for best mowing performance. See "TO LEVEL MOWER HOUSING" in the Service and Adjustments section of this manual.
- The left hand side of mower should be used for trimming.
- Drive so that clippings are discharged onto the area that has been cut. Have the cut area to the right of the tractor. This will result in a more even distribution of clippings and more uniform cutting.
- When mowing large areas, start by turning to the right so that clippings will discharge away from shrubs, fences, driveways, etc. After one or two rounds, mow in the opposite direction making left hand turns until finished.
- If grass is extremely tall, it should be mowed twice to reduce load and possible fire hazard from dried clippings. Make first cut relatively high; the second to the desired height.
- Do not mow grass when it is wet. Wet grass will plug mower and leave undesirable clumps. Allow grass to dry before mowing.
- **Always operate engine at full throttle when mowing** to assure better mowing performance and proper discharge of material. Regulate ground speed by selecting a low enough gear to give the mower the best cutting performance as well as the quality of cut desired.
- When operating attachments, select a ground speed that will suit the terrain and give best performance of the attachment being used.

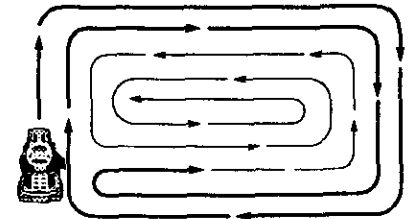

MULCHING MOWING TIPS

IMPORTANT: For best performance, keep mower housing free of built-up grass and trash. Clean after each use.

- The special mulching blade will recut the grass clippings many times and reduce them in size so that as they fall onto the lawn they will disperse into the grass and not be noticed. Also, the mulched grass will biodegrade quickly to provide nutrients for the lawn. Always mulch with your highest engine (blade) speed as this will provide the best re-cutting action of the blades.
 - Avoid cutting your lawn when it is wet. Wet grass tends to form clumps and interferes with the mulching action. The best time to mow your lawn is the early afternoon. At this time the grass has dried and the newly cut area will not be exposed to the direct sun.
 - For best results, adjust the mower cutting height so that the mower cuts off only the top one-third of the grass blades. For extremely heavy mulching, reduce your width of cut on each pass and mow slowly.
- Certain types of grass and grass conditions may require that an area be mulched a second time to completely hide the clippings. When doing a second cut, mow across or perpendicular to the first cut path.
 - Change your cutting pattern from week to week. Mow north to south one week then change to east to west the next week. This will help prevent matting and graining of the lawn.

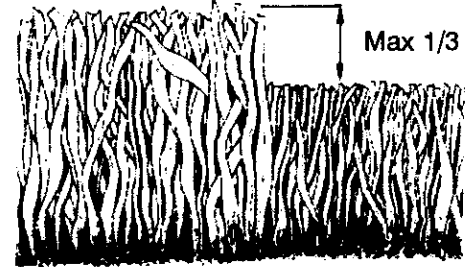

MAINTENANCE

CUSTOMER RESPONSIBILITIES

MAINTENANCE SCHEDULE		SERVICE DATES								
		BEFORE EACH USE	EVERY 8 HOURS	EVERY 25 HOURS	EVERY 50 HOURS	EVERY 100 HOURS	EVERY SEASON	BEFORE STORAGE		
TRACTOR	Check Brake Operation	✓	✓							
	Check Tire Pressure	✓	✓							
	Check Operator Presence and Interlock Systems	✓								
	Check for Loose Fasteners	✓				✓ ₇	✓			
	Sharpen/Replace Mower Blades			✓ ₄						
	Lubrication Chart			✓			✓			
	Check Battery Level			✓ ₆						
	Clean Battery and Terminals			✓				✓		
	Check Transaxle Cooling			✓						
	Adjust Blade Belt(s) Tension						✓ ₅			
Adjust Motion Drive Belt(s) Tension						✓ ₅				
ENGINE	Check Engine Oil Level	✓	✓							
	Change Engine Oil			✓ _{12,3}				✓		
	Clean Air Filter			✓ ₂						
	Clean Air Screen			✓ ₂						
	Inspect Muffler/Spark Arrester				✓					
	Replace Oil Filter (If equipped)						✓ _{1,2}			
	Clean Engine Cooling Fins						✓ ₂			
	Replace Spark Plug						✓	✓		
	Replace Air Filter Paper Cartridge						✓ ₂			
	Replace Fuel Filter								✓	

- 1 - Change more often when operating under a heavy load or in high ambient temperatures.
 2 - Service more often when operating in dirty or dusty conditions.
 3 - If equipped with oil filter, change oil every 50 hours.
 4 - Replace blades more often when mowing in sandy soil.
 5 - If equipped with adjustable system.
 6 - Not required if equipped with maintenance-free battery.
 7 - Tighten front axle pivot bolt to 35 ft.-lbs. maximum. Do not overtighten.

GENERAL RECOMMENDATIONS

The warranty on this tractor does not cover items that have been subjected to operator abuse or negligence. To receive full value from the warranty, operator must maintain tractor as instructed in this manual. Some adjustments will need to be made periodically to properly maintain your tractor.

All adjustments in the Service and Adjustments section of this manual should be checked at least once each season.

- Once a year you should replace the spark plug, clean or replace air filter, and check blades and belts for wear. A new spark plug and clean air filter assure proper air-fuel mixture and help your engine run better and last longer.

BEFORE EACH USE

- Check engine oil level.
- Check brake operation.
- Check tire pressure.
- Check operator presence and interlock systems for proper operation.
- Check for loose fasteners.

LUBRICATION CHART

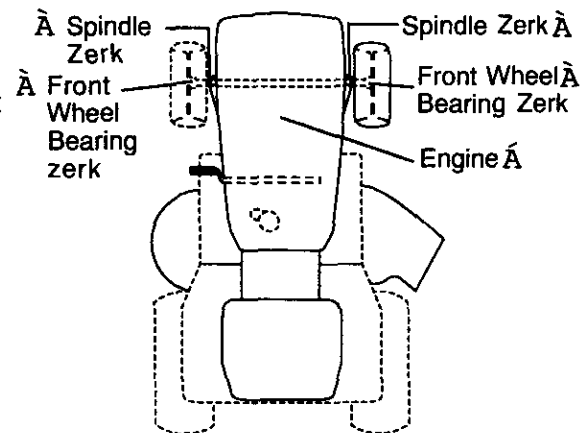

- Spindle Zerk
 - Front Wheel Bearing zerk
 - Spindle Zerk
 - Front Wheel Bearing Zerk
 - Engine
- Z - General Purpose Grease
 A - Refer to Maintenance "ENGINE" Section

IMPORTANT: Do not oil or grease the pivot points which have special nylon bearings. Viscous lubricants will attract dust and dirt that will shorten the life of the self-lubricating bearings. If you feel they must be lubricated, use only a dry, powdered graphite type lubricant sparingly.

TRACTOR

Always observe safety rules when performing any maintenance.

BRAKE OPERATION

If tractor requires more than six (6) feet stopping distance at high speed in highest gear, then brake must be adjusted. (See "TO ADJUST BRAKE" in the Service and Adjustments section of this manual).

TIRES

- Maintain proper air pressure in all tires (See "PRODUCT SPECIFICATIONS" section of this manual).
- Keep tires free of gasoline, oil, or insect control chemicals which can harm rubber.
- Avoid stumps, stones, deep ruts, sharp objects and other hazards that may cause tire damage.

NOTE: To seal tire punctures and prevent flat tires due to slow leaks, tire sealant may be purchased from your local parts dealer. Tire sealant also prevents tire dry rot and corrosion.

OPERATOR PRESENCE SYSTEM

Be sure that operator presence and interlock systems are working properly. If your tractor does not function as described below, repair the problem immediately.

- The engine should not start unless the clutch/brake pedal is fully depressed and attachment clutch control is in the disengaged position.
- When the engine is running, any attempt by the operator to leave the seat without first setting the parking brake should shut off the engine.
- When the engine is running and the attachment clutch is engaged, any attempt by the operator to leave the seat should shut off the engine.
- The attachment clutch should never operate unless the operator is in the seat.

BLADE CARE

For best results mower blades must be kept sharp. Replace bent or damaged blades.

BLADE REMOVAL

- Raise mower to highest position to allow access to blades.
- Remove hex bolt, lock washer and flat washer securing blade.
- Install new or resharpened blade with trailing edge up towards deck as shown.

IMPORTANT: To ensure proper assembly, center hole in blade must align with star on mandrel assembly.

- Reassemble hex bolt, lock washer and flat washer in exact order as shown.
- Tighten bolt securely (27-35 Ft. Lbs. torque).

IMPORTANT: Blade bolt is Grade 8 heat treated.

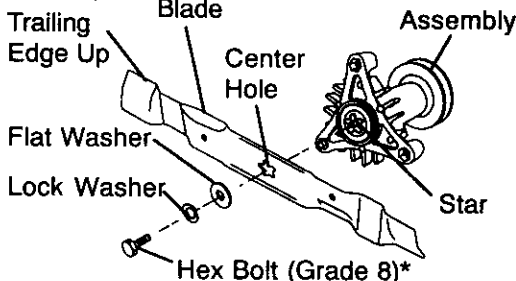

*A Grade 8 heat treated bolt can be identified by six lines on the bolt head.

TO SHARPEN BLADE

NOTE: We do not recommend sharpening blade, but if you do, be sure the blade is balanced.

Care should be taken to keep the blade balanced. An unbalanced blade will cause excessive vibration and eventual damage to mower and engine.

- The blade can be sharpened with a file or on a grinding wheel. Do not attempt to sharpen while it is on the mower.
- To check blade balance, you will need a 5/8" diameter steel bolt, pin, or a cone balancer. (When using a cone balancer, follow the instructions supplied with balancer).

NOTE: Do not use a nail for balancing blade. The lobes of the center hole may appear to be centered, but are not.

- Slide blade onto an unthreaded portion of the steel bolt or pin and hold the bolt or pin parallel with the ground. If blade is balanced, it should remain in a horizontal position. If either end of the blade moves downward, sharpen the heavy end until the blade is balanced.

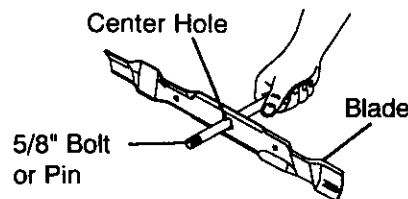

BATTERY

Your tractor has a battery charging system which is sufficient for normal use. However, periodic charging of the battery with an automotive charger will extend its life.

- Keep battery and terminals clean.
- Keep battery bolts tight.
- Keep small vent holes open.
- Recharge at 6-10 amperes for 1 hour.

NOTE: The original equipment battery on your tractor is maintenance free. Do not attempt to open or remove caps or covers. Adding or checking level of electrolyte is not necessary.

TO CLEAN BATTERY AND TERMINALS

Corrosion and dirt on the battery and terminals can cause the battery to "leak" power.

- Open battery box door.
- Disconnect **BLACK** battery cable first then **RED** battery cable and remove battery from tractor.
- Rinse the battery with plain water and dry.
- Clean terminals and battery cable ends with wire brush until bright.
- Coat terminals with grease or petroleum jelly.
- Reinstall battery (See "REPLACING BATTERY" in the SERVICE AND ADJUSTMENTS section of this manual).

V-BELTS

Check V-belts for deterioration and wear after 100 hours of operation and replace if necessary. The belts are not adjustable. Replace belts if they begin to slip from wear.

TRANSAXLE COOLING

The transmission fan and cooling fins should be kept clean to assure proper cooling.

Do not attempt to clean fan or transmission while engine is running or while the transmission is hot.

- Inspect cooling fan to be sure fan blades are intact and clean.
- Inspect cooling fins for dirt, grass clippings and other materials. To prevent damage to seals, do not use compressed air or high pressure sprayer to clean cooling fins.

TRANSAXLE PUMP FLUID

The transaxle was sealed at the factory and fluid maintenance is not required for the life of the transaxle. Should the transaxle ever leak or require servicing, contact your nearest authorized service center/department.

ENGINE

LUBRICATION

Only use high quality detergent oil rated with API service classification SF, SG or SH. Select the oil's SAE viscosity grade according to your expected operating temperature.

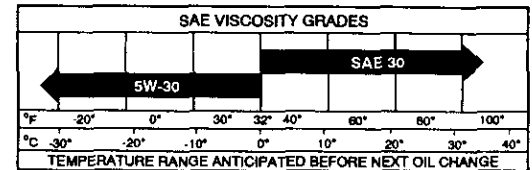

NOTE: Although multi-viscosity oils (5W30, 10W30 etc.) improve starting in cold weather, these multi-viscosity oils will result in increased oil consumption when used above 32°F. Check your engine oil level more frequently to avoid possible engine damage from running low on oil. Change the oil after every 25 hours of operation or at least once a year if the tractor is not used for 25 hours in one year.

Check the crankcase oil level before starting the engine and after each eight (8) hours of operation. Tighten oil fill cap/dipstick securely each time you check the oil level.

TO CHANGE ENGINE OIL

Determine temperature range expected before oil change. All oil must meet API service classification SF, SG or SH.

- Be sure tractor is on level surface.
- Oil will drain more freely when warm.
- Catch oil in a suitable container.
- Remove oil fill cap/dipstick. Be careful not to allow dirt to enter the engine when changing oil.
- Remove drain plug.
- After oil has drained completely, replace oil drain plug and tighten securely.
- Refill engine with oil through oil fill dipstick tube. Pour slowly. Do not overfill. For approximate capacity see "PRODUCT SPECIFICATIONS" section of this manual.
- Use gauge on oil fill cap/dipstick for checking level. Be sure dipstick cap is tightened securely for accurate reading. Keep oil at "FULL" line on dipstick.

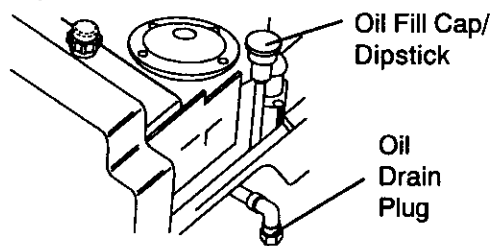

CLEAN AIR SCREEN

Air screen must be kept free of dirt and chaff to prevent engine damage from overheating. Clean with a wire brush or compressed air to remove dirt and stubborn dried gum fibers.

ENGINE COOLING FINS

Remove any dust, dirt or oil from engine cooling fins to prevent engine damage from overheating.

- Remove screws from blower housing and lift housing and dipstick tube assembly off engine.
- Cover oil fill opening to prevent entry of dirt.
- Use compressed air or stiff bristle brush to thoroughly clean engine cooling fins.
- To reassemble, reverse above procedure.

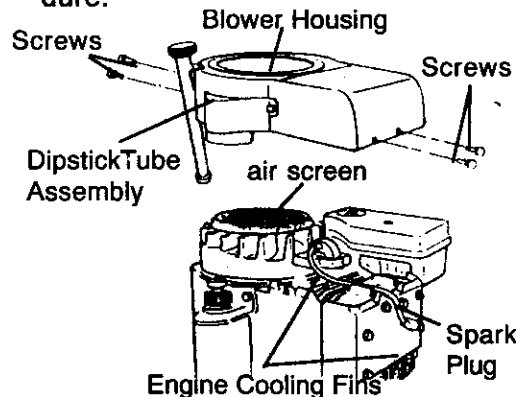

AIR FILTER

Your engine will not run properly using a dirty air filter. Clean the foam pre-cleaner after every 25 hours of operation or every season. Service paper cartridge every 100 hours of operation or every season, whichever occurs first.

Service air cleaner more often under dusty conditions.

- Remove knob(s) and cover.

TO SERVICE PRE-CLEANER

- Slide foam pre-cleaner off cartridge.
- Wash it in liquid detergent and water.
- Squeeze it dry in a clean cloth.
- Saturate it in engine oil. Wrap it in clean, absorbent cloth and squeeze to remove excess oil.
- If very dirty or damaged, replace pre-cleaner.

- Reinstall pre-cleaner over cartridge.
- Reinstall cover and secure with knob(s).

TO SERVICE CARTRIDGE

- Remove cartridge nut.
- Carefully remove cartridge to prevent debris from entering carburetor. Clean base carefully to prevent debris from entering carburetor.
- Clean cartridge by tapping gently on flat surface. If very dirty or damaged, replace cartridge.
- Reinstall cartridge, nut, pre-cleaner, cover and secure with knob(s).

IMPORTANT: Petroleum solvents, such as kerosene, are not to be used to clean the cartridge. They may cause deterioration of the cartridge. Do not oil cartridge. Do not use pressurized air to clean or dry cartridge.

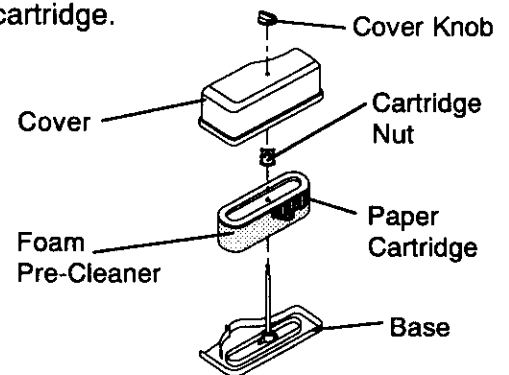

MUFFLER

Inspect and replace corroded muffler and spark arrester (if equipped) as it could create a fire hazard and/or damage.

SPARK PLUGS

Replace spark plugs at the beginning of each mowing season or after every 100 hours of operation, whichever occurs first. Spark plug type and gap setting are shown in "PRODUCT SPECIFICATIONS" section of this manual.

IN-LINE FUEL FILTER

The fuel filter should be replaced once each season. If fuel filter becomes clogged, obstructing fuel flow to carburetor, replacement is required.

- With engine cool, remove filter and plug fuel line sections.
- Place new fuel filter in position in fuel line with arrow pointing towards carburetor.
- Be sure there are no fuel line leaks and clamps are properly positioned.
- Immediately wipe up any spilled gasoline.

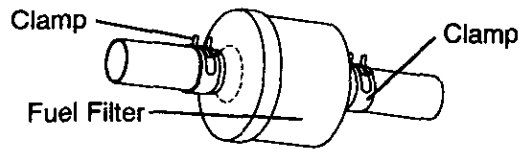

CLEANING

- Clean engine, battery, seat, finish, etc. of all foreign matter.
- Keep finished surfaces and wheels free of all gasoline, oil, etc.

- Protect painted surfaces with automotive type wax.

We do not recommend using a garden hose to clean your tractor unless the electrical system, muffler, air filter and carburetor are covered to keep water out. Water in engine can result in a shortened engine life.

SERVICE AND ADJUSTMENTS

CAUTION: Before performing any service or adjustments:

- Depress clutch/brake pedal fully and set parking brake.
- Place motion control lever in neutral (N) position.
- Place attachment clutch in "DISENGAGED" position.
- Turn ignition key "OFF" and remove key.
- Make sure the blades and all moving parts have completely stopped.
- Disconnect spark plug wire from spark plug and place wire where it cannot come in contact with plug.

TO REMOVE MOWER

Mower will be easier to remove from the right side of tractor.

- Place attachment clutch in "DISENGAGED" position.
- Move attachment lift lever forward to lower mower to its lowest position.
- Roll belt off engine pulley.
- Disconnect clutch rod from clutch lever by removing retainer spring.
- Disconnect anti-swaybar from chassis bracket by removing retainer spring.
- Disconnect suspension arms from rear deck brackets by removing retainer springs.

- Disconnect front links from deck by removing retainer springs.
- Raise lift lever to raise suspension arms. Slide mower out from under tractor.

IMPORTANT: If an attachment other than the mower deck is to be mounted on the tractor, remove the front links.

TO INSTALL MOWER

- Raise attachment lift lever to its highest position.
- Slide mower under tractor with discharge guard to right side of tractor.
- Lower lift lever to its lowest position.
- Install mower in reverse order of removal instructions.

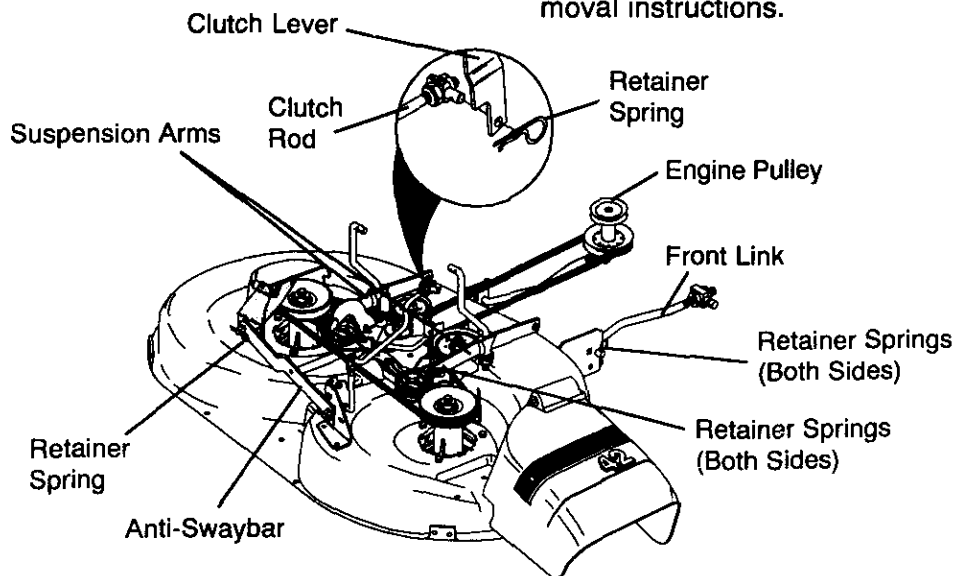

TO LEVEL MOWER HOUSING

Adjust the mower while tractor is parked on level ground or driveway. Make sure tires are properly inflated (See "PRODUCT SPECIFICATIONS"). If tires are over or underinflated, you will not properly adjust your mower.

SIDE-TO-SIDE ADJUSTMENT

- Raise mower to its highest position.
- At the midpoint of both sides of mower, measure height from bottom edge of mower to ground. Distance "A" on both sides of mower should be the same or within 1/4" of each other.
- If adjustment is necessary, make adjustment on one side of mower only.
- To raise one side of mower, tighten lift link adjustment nut on that side.
- To lower one side of mower, loosen lift link adjustment nut on that side.

NOTE: Each full turn of adjustment nut will change mower height about 1/8".

- Recheck measurements after adjusting.

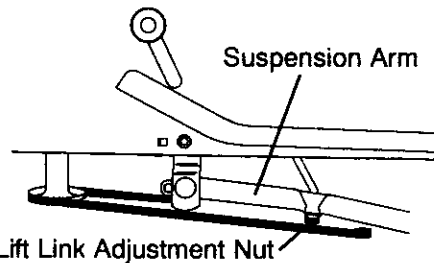
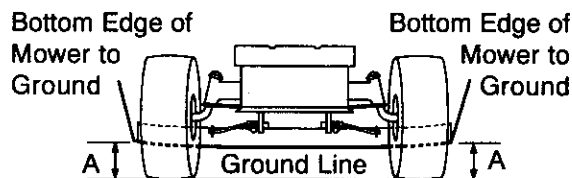

FRONT-TO-BACK ADJUSTMENT

IMPORTANT: Deck must be level side-to-side. If the following front-to-back adjustment is necessary, be sure to adjust both front links equally so mower will stay level side-to-side.

To obtain the best cutting results, the mower housing should be adjusted so that the front is approximately 1/8" to 1/2" lower than the rear when the mower is in its highest position.

Check adjustment on right side of tractor. Measure distance "D" directly in front and behind the mandrel at bottom edge of mower housing as shown.

- Before making any necessary adjustments, check that both front links are equal in length. Both links should be approximately 10-3/8".
- If links are not equal in length, adjust one link to same length as other link.
- To lower front of mower loosen nut "E" on both front links an equal number of turns.
- When distance "D" is 1/8" to 1/2" lower at front than rear, tighten nuts "F" against trunnion on both front links.
- To raise front of mower, loosen nut "F" from trunnion on both front links. Tighten nut "E" on both front links an equal number of turns.
- When distance "D" is 1/8" to 1/2" lower at front than rear, tighten nut "F" against trunnion on both front links.
- Recheck side-to-side adjustment.

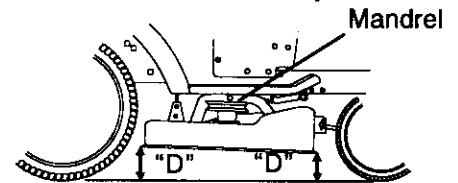

Both Front Links Should be Equal in Length

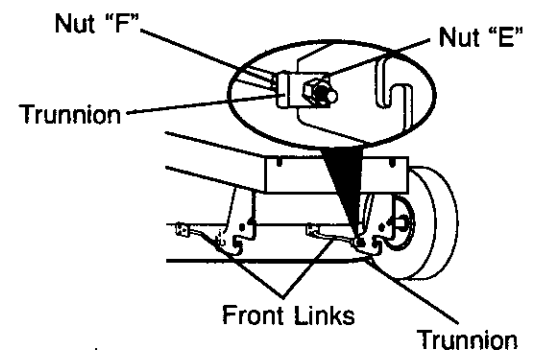
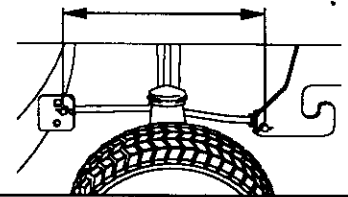

TO REPLACE MOWER BLADE DRIVE BELT

The mower blade drive belt may be replaced without tools. Park the tractor on level surface. Engage parking brake.

BELT REMOVAL -

- Remove mower from tractor (See "TO REMOVE MOWER" in this section of this manual).
- Work belt off both mandrel pulleys and idler pulleys.

- Pull belt away from mower.

BELT INSTALLATION

- Install new belt in reverse order of removal.
- Make sure belt is in all pulley grooves and inside all belt guides.

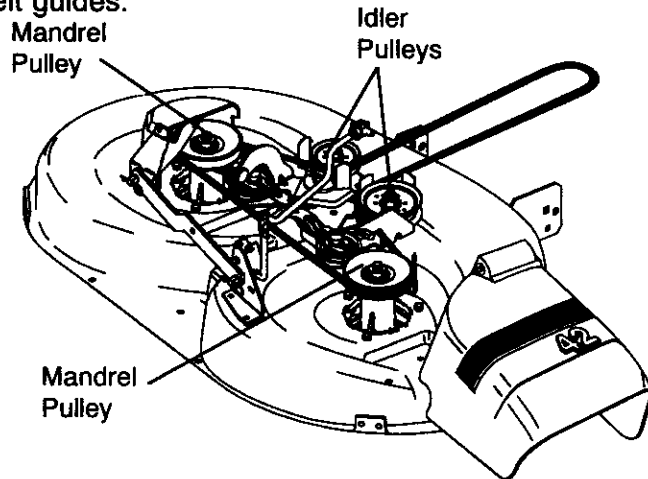

- Install mower in reverse order of removal instructions.

TO ADJUST BRAKE

Your tractor is equipped with an adjustable brake system which is mounted on the side of the transaxle.

If tractor requires more than six (6) feet stopping distance at high speed in highest gear, then brake must be adjusted.

- Depress clutch/brake pedal and engage parking brake.
- Measure distance between brake operating arm and nut "A" on brake rod.
- If distance is other than 1-9/16", loosen jam nut and turn nut "A" until distance becomes 1-9/16". Retighten jam nut against nut "A".
- Road test tractor for proper stopping distance as stated above. Readjust if necessary. If stopping distance is still greater than six (6) feet in highest gear, further maintenance is necessary. Contact your nearest authorized service center/department.

With Parking Brake "Engaged"

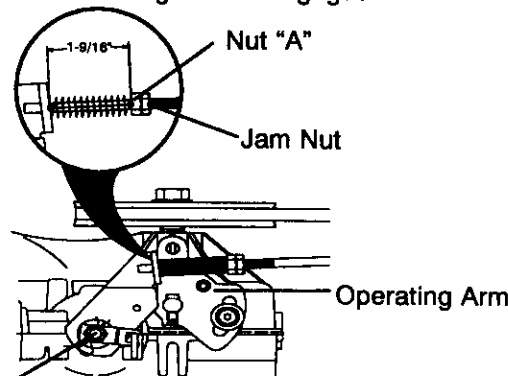

Do Not touch this nut. If further brake adjustment is necessary contact your nearest authorized service center/department

TO REPLACE MOTION DRIVE BELT

Park the tractor on level surface. Engage parking brake. For assistance, there is a belt installation guide decal on bottom side of left footrest.

- Remove mower (See "TO REMOVE MOWER" in this section of this manual.)
- Remove belt from stationary idler and clutching idler.
- Pull belt slack toward rear of tractor. Carefully remove belt upwards from transmission input pulley and over cooling fan blades.
- Pull belt toward front of tractor and remove downward from around engine pulley.
- Install new belt by reversing above procedure.

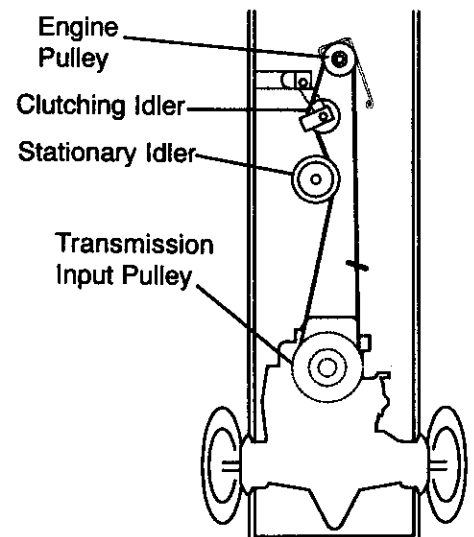

TRANSMISSION REMOVAL/REPLACEMENT

Should your transmission require removal for service or replacement, it should be purged after reinstallation and before operating the tractor. See "PURGE TRANSMISSION" in the Operation section of this manual.

TRANSAXLE MOTION CONTROL LEVER ADJUSTMENT

The motion control lever has been preset at the factory and adjustment should not be necessary.

If for any reason the motion control lever will not hold its position while at a selected speed, it may be adjusted as follows:

- Loosen adjustment bolt in front of the right rear wheel, and lightly tighten.
- Start engine and move motion control lever until tractor does not move forward or backward.
- Hold motion control lever in that position and turn engine off.
- While holding motion control lever in place, loosen the adjustment bolt.
- Move motion control lever to the neutral (N) (lock gate) position.
- Tighten adjustment bolt securely.

NOTE: If additional clearance is needed to get to adjustment bolt, move mower deck height to the lowest position.

After above adjustment is made, if the tractor still creeps forward or backward while motion control lever is in neutral position, follow these steps:

- Loosen the adjustment bolt.
- Move the motion control lever 1/4 to 1/2 inch in the direction it is trying to creep.
- Tighten adjustment bolt securely.
- Start engine and test.
- If tractor still creeps, repeat above steps until satisfied.

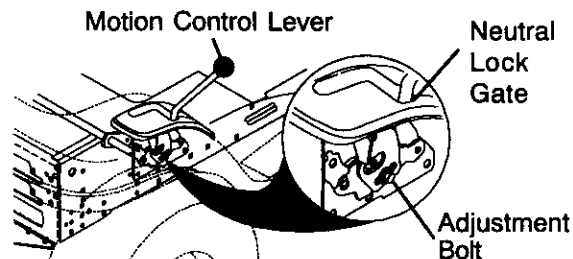

TO ADJUST STEERING WHEEL ALIGNMENT

If steering wheel crossbars are not horizontal (left to right) when wheels are positioned straight forward, remove steering wheel and reassemble per

instructions in the Assembly section of this manual.

FRONT WHEEL TOE-IN/CAMBER

The front wheel toe-in and camber are not adjustable on your tractor. If damage has occurred to affect the front wheel toe-in or camber, contact your nearest authorized service center/department.

TO REMOVE WHEEL FOR REPAIRS

- Block up axle securely.
- Remove axle cover, retaining ring and washers to allow wheel removal (rear wheel contains a square key - Do not lose).
- Repair tire and reassemble.
- On rear wheels only: align grooves in rear wheel hub and axle. Insert square key.
- Replace washers and snap retaining ring securely in axle groove.
- Replace axle cover.

NOTE: To seal tire punctures and prevent flat tires due to slow leaks, tire sealant may be purchased from your local parts dealer. Tire sealant also prevents tire dry rot and corrosion.

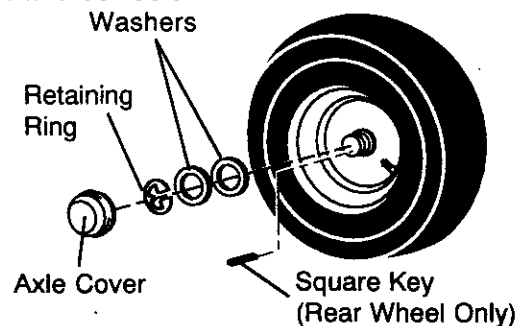

TO START ENGINE THAT HAS A WEAK BATTERY

CAUTION: Lead-acid batteries generate explosive gases. Keep sparks, flame and smoking materials away from batteries. Always wear eye protection when around batteries.

If your battery is too weak to start the engine, it should be recharged. (See "BATTERY" in the MAINTENANCE section of this manual).

If "jumper cables" are used for emergency starting, follow this procedure:

IMPORTANT: Your tractor is equipped with a 12 volt negative grounded system. The other vehical must also be a 12 volt negative grounded system. Do not use your tractor battery to start other vehicals.

TO ATTACH JUMPER CABLES -

- Connect each end of the RED cable to the POSITIVE (+) terminal of each battery, taking care not to short against chassis.
- Connect one end of the BLACK cable to the NEGATIVE (-) terminal of fully charged battery.
- Connect the other end of the BLACK cable to good CHASSIS GROUND, away from fuel tank and battery.

TO REMOVE CABLES, REVERSE ORDER -

- BLACK cable first from chassis and then from the fully charged battery.
- Red cable last from both batteries.

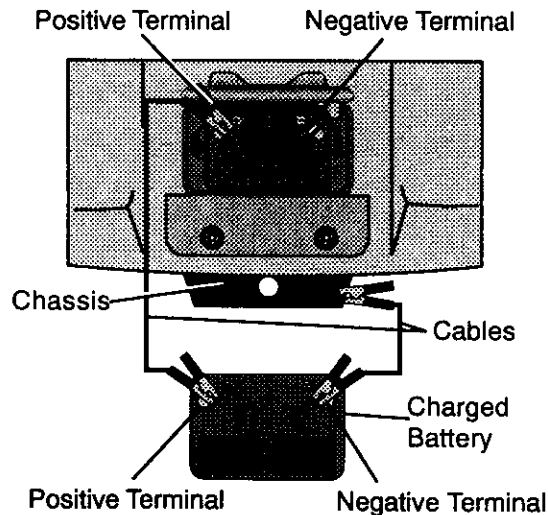

REPLACING BATTERY

⚠ CAUTION: Do not short battery terminals by allowing a wrench or any other object to contact both terminals at the same time. Before connecting battery, remove metal bracelets, wristwatch bands, rings, etc.

Positive terminal must be connected first to prevent sparking from accidental grounding.

- Lift seat pan to raised position and open battery box door.
- Disconnect BLACK battery cable first then RED battery cable and carefully remove battery from tractor.

- Install new battery with terminals in same position as old battery.
- First connect RED battery cable to positive (+) terminal with hex bolt and keps nut as shown. Tighten securely.
- Connect BLACK grounding cable to negative (-) terminal with remaining hex bolt and keps nut. Tighten securely.
- Close battery box door.

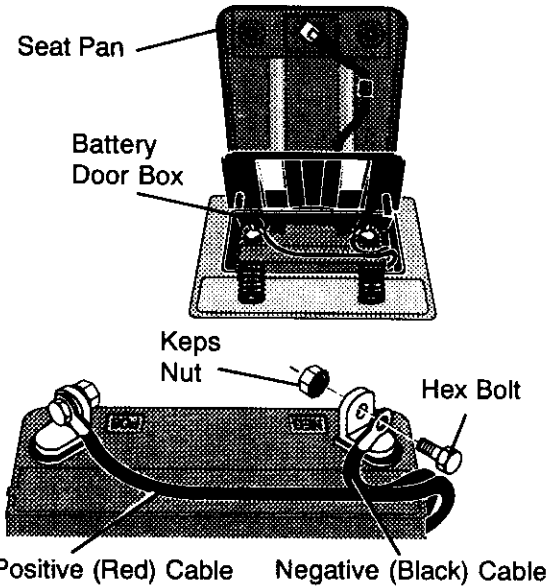

TO REPLACE HEADLIGHT BULB

- Raise hood.
- Pull bulb holder out of the hole in the backside of the grill.
- Replace bulb in holder and push bulb holder securely back into the hole in the backside of the grill.
- Close hood.

INTERLOCKS AND RELAYS

Loose or damaged wiring may cause your tractor to run poorly, stop running, or prevent it from starting.

- Check wiring. See electrical wiring diagram in the Repair Parts section.

TO REPLACE FUSE

Replace with 15 amp automotive-type plug-in fuse. The fuse holder is located behind the dash.

TO REMOVE HOOD AND GRILL ASSEMBLY

- Raise hood.
- Unsnap headlight wire connector.
- Stand in front of tractor. Grasp hood at sides, tilt toward engine and lift off of tractor.
- To replace, reverse above procedures.

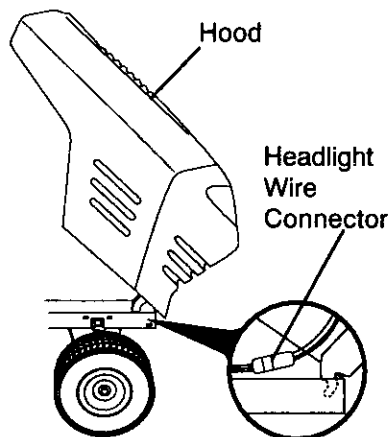

ENGINE

Maintenance, repair, or replacement of the emission control devices and systems, which are being done at the customer's expense, may be performed by any non-road engine repair establishment or individual. Warranty repairs must be performed by an authorized engine manufacturer's service outlet.

TO ADJUST THROTTLE CONTROL CABLE

The throttle control has been preset at the factory and adjustment should not be necessary. Check adjustment as described below before loosening cable. If adjustment is necessary, proceed as follows:

- With engine not running, move throttle control lever from slow to choke position. Slowly move lever from choke to fast position.

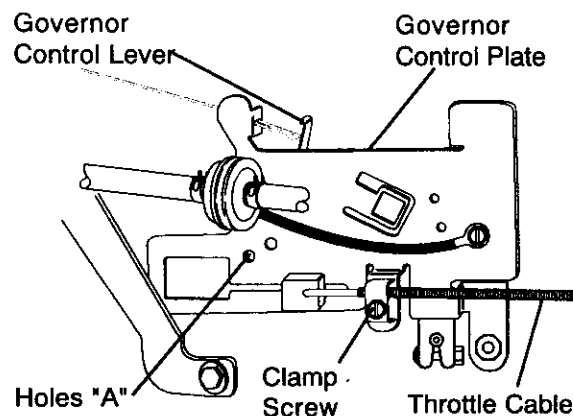

- Check that holes "A" in governor control lever and hole in governor plate line-up. If holes "A" are not aligned, loosen clamp screw and move throttle cable until holes are aligned. Tighten clamp screw securely.

TO ADJUST CARBURETOR

NOTE: The carburetor on this engine is low emission. It is equipped with an idle fuel adjusting needle with a limiter cap, which allows some adjustment within the limits allowed by the cap. Do not attempt to remove the limiter cap. The limiter cap cannot be removed without breaking the adjusting needle.

The carburetor has been preset at the factory and adjustment should not be necessary. However, minor adjustment may be required to compensate for differences in fuel, temperature, altitude or load. If the carburetor does need adjustment, proceed as follows:

In general, turning idle mixture valve **In** (clockwise) decreases the supply of fuel to the engine giving a leaner fuel/air mixture. Turning the idle mixture valve **Out** (counterclockwise) increases the supply of fuel to the engine giving a richer fuel/air mixture.

IMPORTANT: Damage to the needle valve and the seat in carburetor may result if screw is turned in too tight.

PRELIMINARY SETTING

- Air cleaner assembly must be assembled to the carburetor when making carburetor adjustments.
- Be sure the throttle control cable is adjusted properly (see above).

FINAL SETTING

- Start engine and allow to warm for five minutes. Make final adjustments with engine running and shift/motion control lever in neutral (**N**) position.
- Move throttle control lever to slow position. With finger, rotate and hold throttle lever against idle speed screw. Turn idle speed screw to attain 1750 RPM.
- While still holding throttle lever against idle speed screw, turn idle mixture valve full travel clockwise then counterclockwise until engine runs rough. Turn valve to a point midway between those two positions. Release throttle lever.

ACCELERATION TEST

- Move throttle control lever from slow to fast position. If engine hesitates or dies, turn idle mixture valve **out** (counter-clockwise) 1/8 turn. Repeat test and continue to adjust, if necessary, until engine accelerates smoothly.

High speed stop is factory adjusted. Do not adjust - damage may result.

IMPORTANT: Never tamper with the engine governor, which is factory set for proper engine speed. Overspeeding the engine above the factory high speed setting can be dangerous. If you think the engine-governed high speed needs adjusting, contact your nearest authorized service center/department, which has proper equipment and experience to make any necessary adjustments.

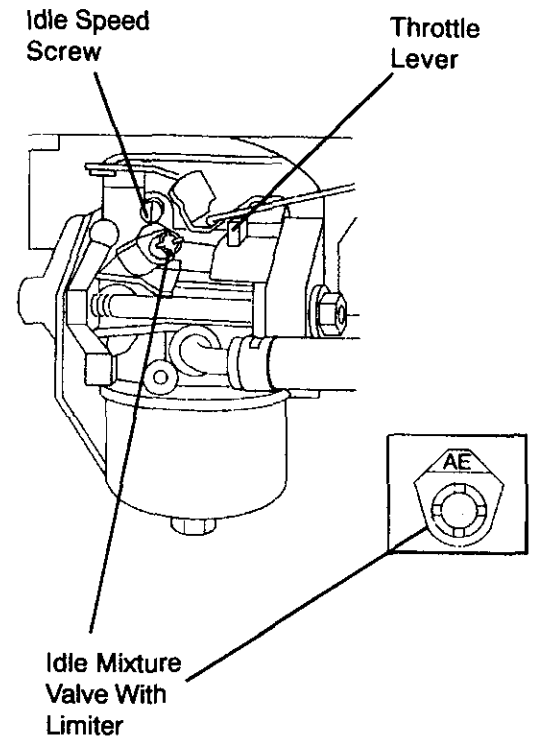

STORAGE

Immediately prepare your tractor for storage at the end of the season or if the tractor will not be used for 30 days or more.

⚠ CAUTION: Never store the tractor with gasoline in the tank inside a building where fumes may reach an open flame or spark. Allow the engine to cool before storing in any enclosure.

TRACTOR

Remove mower from tractor for winter storage. This will allow you to clean it thoroughly. Remove all dirt, grease, leaves, etc. Store in a clean, dry area.

- Clean entire tractor (See "CLEANING" in the Maintenance section of this manual).
- Inspect and replace belts, if necessary (See belt replacement instructions in the Service and Adjustments section of this manual).
- Lubricate as shown in the Maintenance section of this manual.
- Be sure that all nuts, bolts and screws are securely fastened. Inspect moving parts for damage, breakage and wear. Replace if necessary.
- Touch up all rusted or chipped paint surfaces; sand lightly before painting.

BATTERY

- Fully charge the battery for storage.
- After a period of time in storage, battery may require recharging.
- To help prevent corrosion and power leakage during long periods of storage, battery cables should be disconnected and battery cleaned thoroughly (see "TO CLEAN BATTERY AND TERMINALS" in the Maintenance section of this manual).
- After cleaning, leave cables disconnected and place cables where they cannot come in contact with battery terminals.
- If battery is removed from tractor for storage, do not store battery directly on concrete or damp surfaces.

ENGINE

FUEL SYSTEM

IMPORTANT: It is important to prevent gum deposits from forming in essential fuel system parts such as carburetor, fuel

filter, fuel hose, or tank during storage. Also, experience indicates that alcohol blended fuels (called gasohol or using ethanol or methanol) can attract moisture which leads to separation and formation of acids during storage. Acidic gas can damage the fuel system of an engine while in storage.

- Drain the fuel tank.
- Start the engine and let it run until the fuel lines and carburetor are empty.
- Never use engine or carburetor cleaner products in the fuel tank or permanent damage may occur.
- Use fresh fuel next season.

NOTE: Fuel stabilizer is an acceptable alternative in minimizing the formation of fuel gum deposits during storage. Add stabilizer to gasoline in fuel tank or storage container. Always follow the mix ratio found on stabilizer container. Run engine at least 10 minutes after adding stabilizer to allow the stabilizer to reach the carburetor. Do not drain the gas tank and carburetor if using fuel stabilizer.

ENGINE OIL

Drain oil (with engine warm) and replace with clean engine oil. (See "ENGINE" in the Maintenance section of this manual).

CYLINDER(S)

- Remove spark plug(s).
- Pour one ounce of oil through spark plug hole(s) into cylinder(s).
- Turn ignition key to "START" position for a few seconds to distribute oil.
- Replace with new spark plug(s).

OTHER

- Do not store gasoline from one season to another.
- Replace your gasoline can if it starts to rust. Rust and/or dirt in your gasoline will cause problems.
- If possible, store your tractor indoors and cover it to give protection from dust and dirt.
- Cover your tractor with a suitable protective cover that does not retain moisture. Do not use plastic. Plastic cannot breathe, which allows condensation to form and cause your tractor to rust.

IMPORTANT: Never cover tractor while engine and exhaust areas are still warm.

TROUBLESHOOTING CHART

PROBLEM	CAUSE	CORRECTION
Will not start	<ul style="list-style-type: none"> • Out of fuel. • Engine not "CHOKED" properly. • Engine flooded. • Bad spark plug. • Dirty air filter. • Dirty fuel filter. • Water in fuel. • Loose or damaged wiring. • Carburetor out of adjustment. • Engine valves out of adjustment. 	<ul style="list-style-type: none"> • Fill fuel tank. • See "TO START ENGINE" in Operation section. • Wait several minutes before attempting to start. • Replace spark plug. • Clean/replace air filter. • Replace fuel filter. • Drain fuel tank and carburetor, refill tank with fresh gasoline and replace fuel filter. • Check all wiring. • See "To Adjust Carburetor" in Service and Adjustments section. • Contact an authorized service center.
Hard to start	<ul style="list-style-type: none"> • Dirty air filter. • Bad spark plug. • Weak or dead battery. • Dirty fuel filter. • Stale or dirty fuel. • Loose or damaged wiring. • Carburetor out of adjustment. • Engine valves out of adjustment. 	<ul style="list-style-type: none"> • Clean/replace air filter. • Replace spark plug. • Recharge or replace battery. • Replace fuel filter. • Drain fuel tank and refill with fresh gasoline. • Check all wiring. • See "To Adjust Carburetor" in Service and Adjustments section. • Contact an authorized service center.
Engine will not turn over	<ul style="list-style-type: none"> • Clutch/brake pedal not depressed. • Attachment clutch is engaged. • Weak or dead battery. • Blown fuse. • Corroded battery terminals. • Loose or damaged wiring. • Faulty ignition switch. • Faulty solenoid or starter. • Faulty operator presence switch(es). 	<ul style="list-style-type: none"> • Depress clutch/brake pedal. • Disengage attachment clutch. • Recharge or replace battery. • Replace fuse. • Clean battery terminals. • Check all wiring. • Check/replace ignition switch. • Check/replace solenoid or starter. • Contact an authorized service center.
Engine clicks but will not start	<ul style="list-style-type: none"> • Weak or dead battery. • Corroded battery terminals. • Loose or damaged wiring. • Faulty solenoid or starter. 	<ul style="list-style-type: none"> • Recharge or replace battery. • Clean battery terminals. • Check all wiring. • Check/replace solenoid or starter.
Loss of power	<ul style="list-style-type: none"> • Cutting too much grass/too fast. • Throttle in "CHOKE" position. • Build-up of grass, leaves and trash under mower. • Dirty air filter. • Low oil level/dirty oil. 	<ul style="list-style-type: none"> • Set in "Higher Cut" position/reduce speed. • Adjust throttle control. • Clean underside of mower housing. • Clean/replace air filter. • Check oil level/change oil.

TROUBLESHOOTING CHART

PROBLEM	CAUSE	CORRECTION
Loss of power (cont'd)	<ul style="list-style-type: none"> • Faulty spark plug. • Dirty fuel filter. • Stale or dirty fuel. • Water in fuel. • Spark plug wire loose. • Dirty engine air screen/fins. • Dirty/clogged muffler. • Loose or damaged wiring. • Carburetor out of adjustment. • Engine valves out of adjustment. 	<ul style="list-style-type: none"> • Clean and regap or change spark plug. • Replace fuel filter. • Drain fuel tank and refill with fresh gasoline. • Drain fuel tank and carburetor, refill tank with fresh gasoline and replace fuel filter. • Connect and tighten spark plug wire. • Clean engine air screen/fins. • Clean/replace muffler. • Check all wiring. • See "To Adjust Carburetor" in Service and Adjustments section. • Contact an authorized service center.
Excessive vibration	<ul style="list-style-type: none"> • Worn, bent or loose blade. • Bent blade mandrel. • Loose/damaged part(s). 	<ul style="list-style-type: none"> • Replace blade. Tighten blade bolt. • Replace blade mandrel. • Tighten loose part(s). Replace damaged parts.
Engine continues to run when operator leaves seat with attachment clutch engaged	<ul style="list-style-type: none"> • Faulty operator-safety presence control system. 	<ul style="list-style-type: none"> • Check wiring, switches and connections. If not corrected, contact an authorized service center/department.
Poor cut uneven	<ul style="list-style-type: none"> • Worn, bent or loose blade. • Mower deck not level. • Buildup of grass, leaves, and trash under mower. • Bent blade mandrel. • Clogged mower deck vent holes from buildup of grass, leaves, and trash around mandrels. 	<ul style="list-style-type: none"> • Replace blade. Tighten blade bolt. • Level mower deck. • Clean underside of mower housing. • Replace blade mandrel. • Clean around mandrels to open vent holes.
Mower blades will not rotate	<ul style="list-style-type: none"> • Obstruction in clutch mechanism. • Worn/damaged mower drive belt. • Frozen idler pulley. • Frozen blade mandrel. 	<ul style="list-style-type: none"> • Remove obstruction. • Replace mower drive belt. • Replace idler pulley. • Replace blade mandrel.
Poor grass discharge	<ul style="list-style-type: none"> • Engine speed too slow. • Travel speed too fast. • Wet grass. • Mower deck not level. • Low/uneven tire air pressure. • Worn, bent or loose blade. 	<ul style="list-style-type: none"> • Place throttle control in "FAST" position. • Shift to slower speed. • Allow grass to dry before mowing. • Level mower deck. • Check tires for proper air pressure. • Replace/sharpen blade. Tighten blade bolt.

TROUBLESHOOTING CHART

PROBLEM	CAUSE	CORRECTION
Poor grass discharge (cont'd)	<ul style="list-style-type: none"> • Buildup of grass, leaves and trash under mower. • Mower drive belt worn. • Blades improperly installed. • Improper blades used. • Clogged mower deck vent holes from buildup of grass, leaves, and trash around mandrels. 	<ul style="list-style-type: none"> • Clean underside of mower housing. • Replace mower drive belt. • Reinstall blades sharp edge down. • Replace with blades listed in this manual. • Clean around mandrels to open vent holes.
Headlight(s) not working (if so equipped)	<ul style="list-style-type: none"> • Switch is "OFF". • Bulb(s) burned out. • Faulty light switch. • Loose or damaged wiring. • Blown fuse. 	<ul style="list-style-type: none"> • Turn switch "ON". • Replace bulb(s). • Check/replace light switch. • Check wiring and connections. • Replace fuse.
Battery will not charge	<ul style="list-style-type: none"> • Bad battery cell(s). • Poor cable connections. • Faulty regulator (if so equipped). • Faulty alternator. 	<ul style="list-style-type: none"> • Replace battery. • Check/clean all connections. • Replace regulator. • Replace alternator.
Loss of drive	<ul style="list-style-type: none"> • Freewheel control in "disengaged" position. • Motion drive belt worn, damaged or broken. • Air trapped in transmission during shipment or servicing. 	<ul style="list-style-type: none"> • Place freewheel control in "engaged" position. • Replace motion drive belt. • Purge transmission.
Engine "backfires" when turning engine "OFF"	<ul style="list-style-type: none"> • Engine throttle control not set at "SLOW" position for 30 seconds before stopping engine. 	<ul style="list-style-type: none"> • Move throttle control to "SLOW" position and allow to idle for 30 seconds before stopping engine.

TRACTOR -- MODEL NUMBER 917.270660

SCHEMATIC

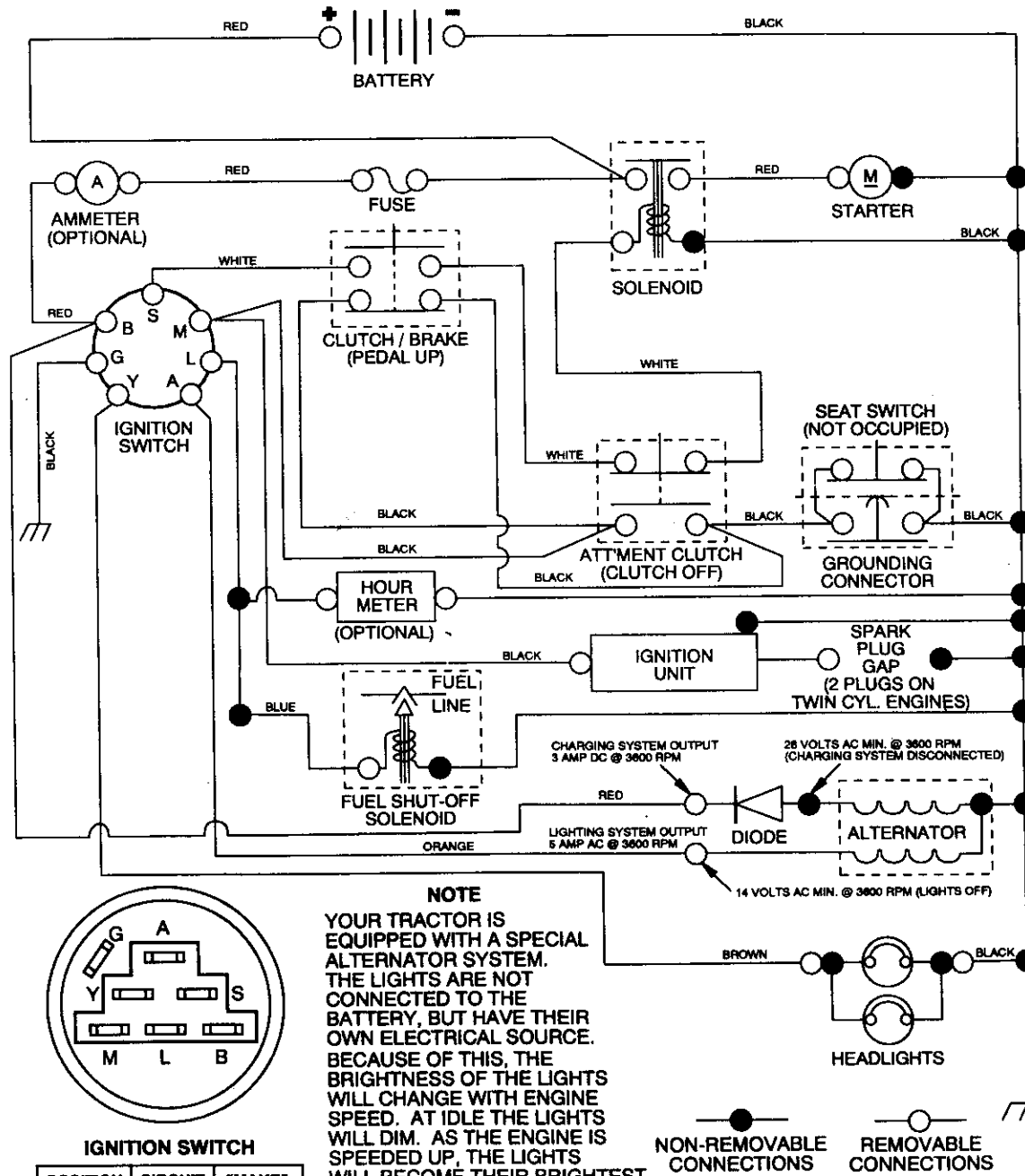

REPAIR PARTS

TRACTOR -- MODEL NUMBER 917.270660

ELECTRICAL

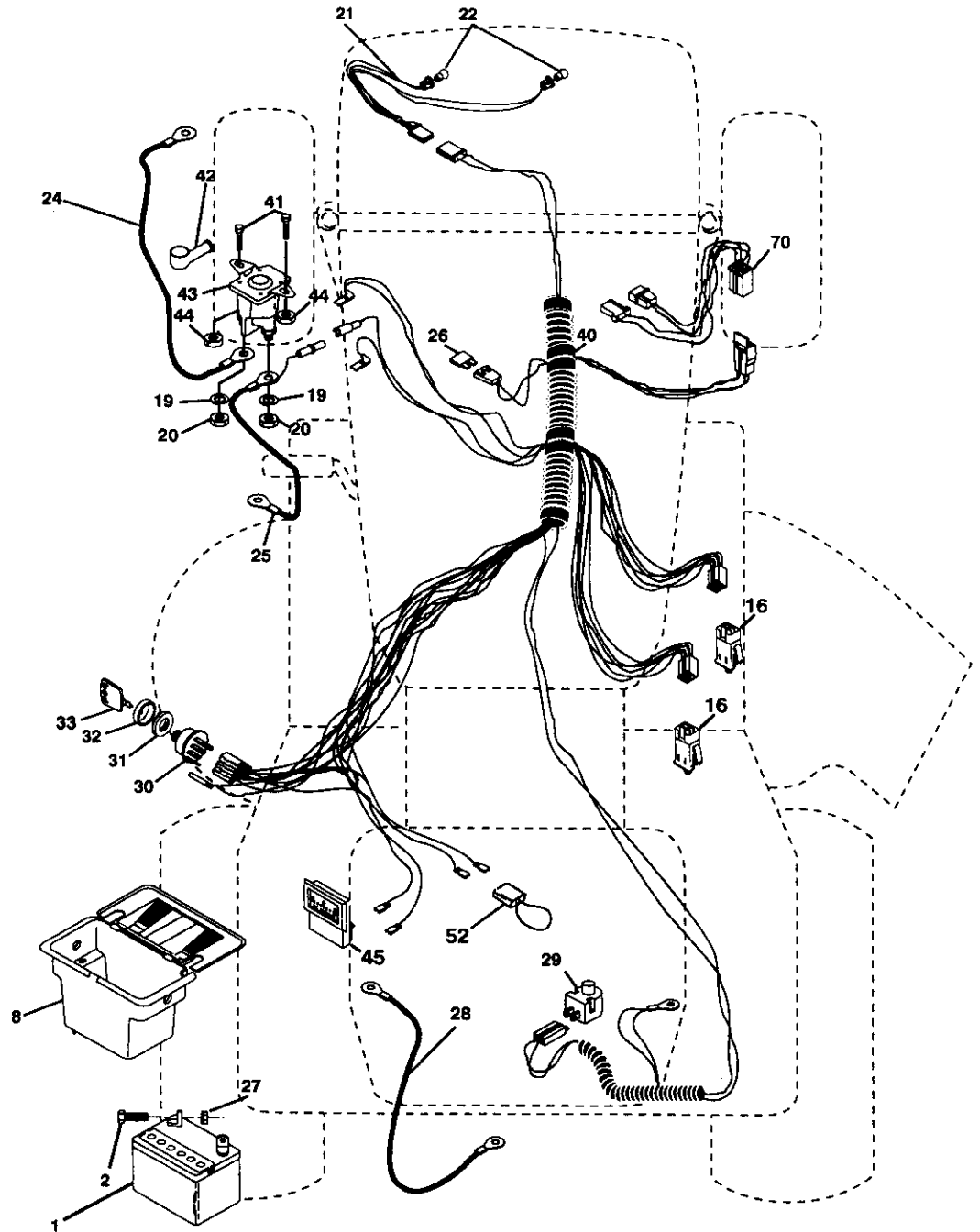

TRACTOR -- MODEL NUMBER 917.270660

ELECTRICAL

KEY NO.	PART NO.	DESCRIPTION
1	144925	Battery 12 VOLT 25 AMP
2	74760412	Bolt Hex Hd 1/4-20unc x 3/4
4	STD551125	Washer Lock Hvy Helical 1/4
8	156417	Case Battery
16	153664	Switch, Interlock Push-In
19	STD551125	Washer Lock 1/4
20	73350400	Nut Jam Hex 1/4-20 Unc
21	166182	Harness Asm Light W/4152j
22	4152J	Bulb Light #1156
24	4799J	Cable Battery 6 Ga 11" red
25	146147	Cable Battery 6 Ga w/16 wire red
26	166180	Fuse 15 AMP
27	73510400	Nut Keps Hex 1/4-20 Unc
28	4207J	Cable Ground 6 Ga 12" black
29	121305X	Switch Plunger Nc Gray
30	140301	Switch Ign 4 Pos
31	124211X	Nut Ignition
32	141226	Cover Sw Key Blk 1 25 Text SLT
33	109310X	Key Ign Molded Craftsman
40	166145	Harness Ign Man Cl Am Hm 97
41	71110408	Bolt Blk. Fin Hex 1/4-20 Unc x 1/2
42	131563	Cover Terminal Red
43	145673	Solenoid
44	73640400	Nut Keps Blk Hex 1/4-20 Unc
45	121433X	Ammeter Rectangular 6 Amp
52	141940	Protection Wire Loop
70	166659	Harness Engine

NOTE: All component dimensions given in U.S. inches
1 inch = 25.4 mm

TRACTOR -- MODEL NUMBER 917.270660
CHASSIS AND ENCLOSURES

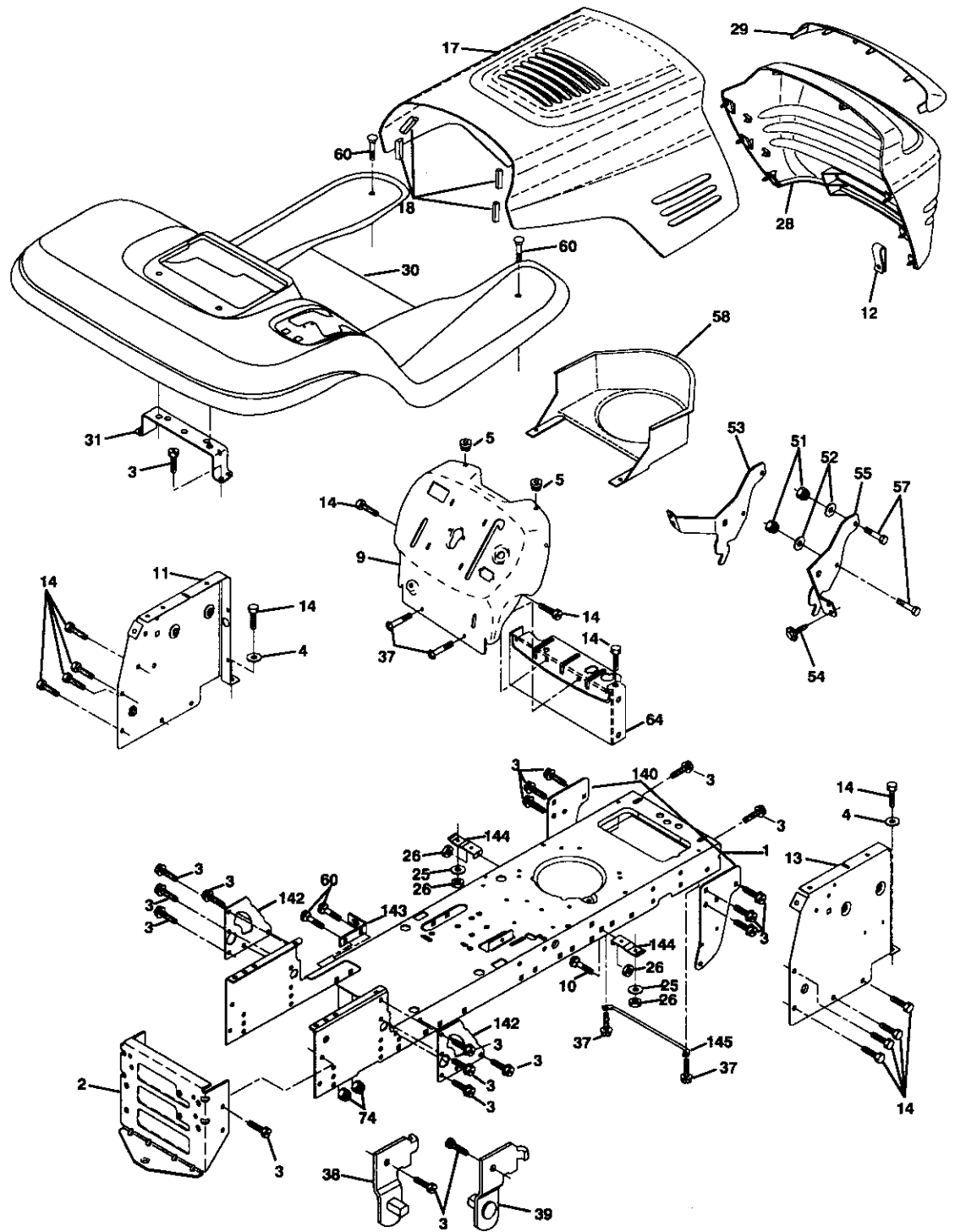

TRACTOR - - MODEL NUMBER 917.270660
CHASSIS AND ENCLOSURES

KEY NO.	PART NO.	DESCRIPTION
1	165583	Chassis
2	140356	Drawbar
3	17490612	Screw, Thd. Roll. 3/8-16 x 3/4
4	19131216	Washer 13/32 x 3/4 x 16 Gauge
5	155272	Bumper Hood/Dash
9	161917X013	Dash
10	STD533710	Bolt, Carriage 3/8-16 x 3/4
11	155927	Panel, Dash, L.H.
12	145660	Clip Tinnerman Grille P/L
13	155934X010	Panel, Dash, R.H.
14	17490608	Screw Thdrol 3/8-16 x 1/2
17	144983X558	Hood Assembly
18	126938X	Bumper Hood
25	19131312	Washer 13/32 x 13/16 x 12 Gauge
26	STD541437	Nut
28	145198X558	Grille w/Clips MS-558
29	155217X599	Lens, Grille
30	151287X558	Fend/Frest Pnt STLT N HLD 558
31	139976	Bracket, Fender Support
37	17490508	Screw Thdrol 5/16-18 x 1/2
38	139886	Pivot Bracket Assembly, L.H.
39	139887	Pivot Bracket Assembly, R.H.
51	73800400	Nut Lock w/Insert 1/4-20 UNC
52	19091416	Washer 9/32 x 7/8 x 16 Ga.
53	145201	Bracket Grille Pickoff LH
54	161464	Screw Hex Wshd 8-18 x 7/8
55	145202	Bracket Grille Pickoff RH
57	STD522507	Bolt, Fin Hex 1/4-20 UNC x .75
60	72140606	Bolt Rdhd Sqnk 3/8-16 UNC x 3/4
64	154798	Dash Lower STLT
74	STD541437	Nut Crownlock 3/8016 UNC
140	158418	Bracket Suspension Front
142	165867	Plate Reinforcement STLT
143	154966	Bracket Swaybar Chassis
144	154207	Bracket Pnt Footrest STLT
145	156524	Rod Pivot Chassis/Hood
191	74780612	Bolt Fin Hex 3/8-16unc x 3/4 Gr. 5
- -	5479J	Plug, Button

NOTE: All component dimensions given in U.S. inches
1 inch = 25.4 mm

TRACTOR - - MODEL NUMBER 917.270660

GROUND DRIVE

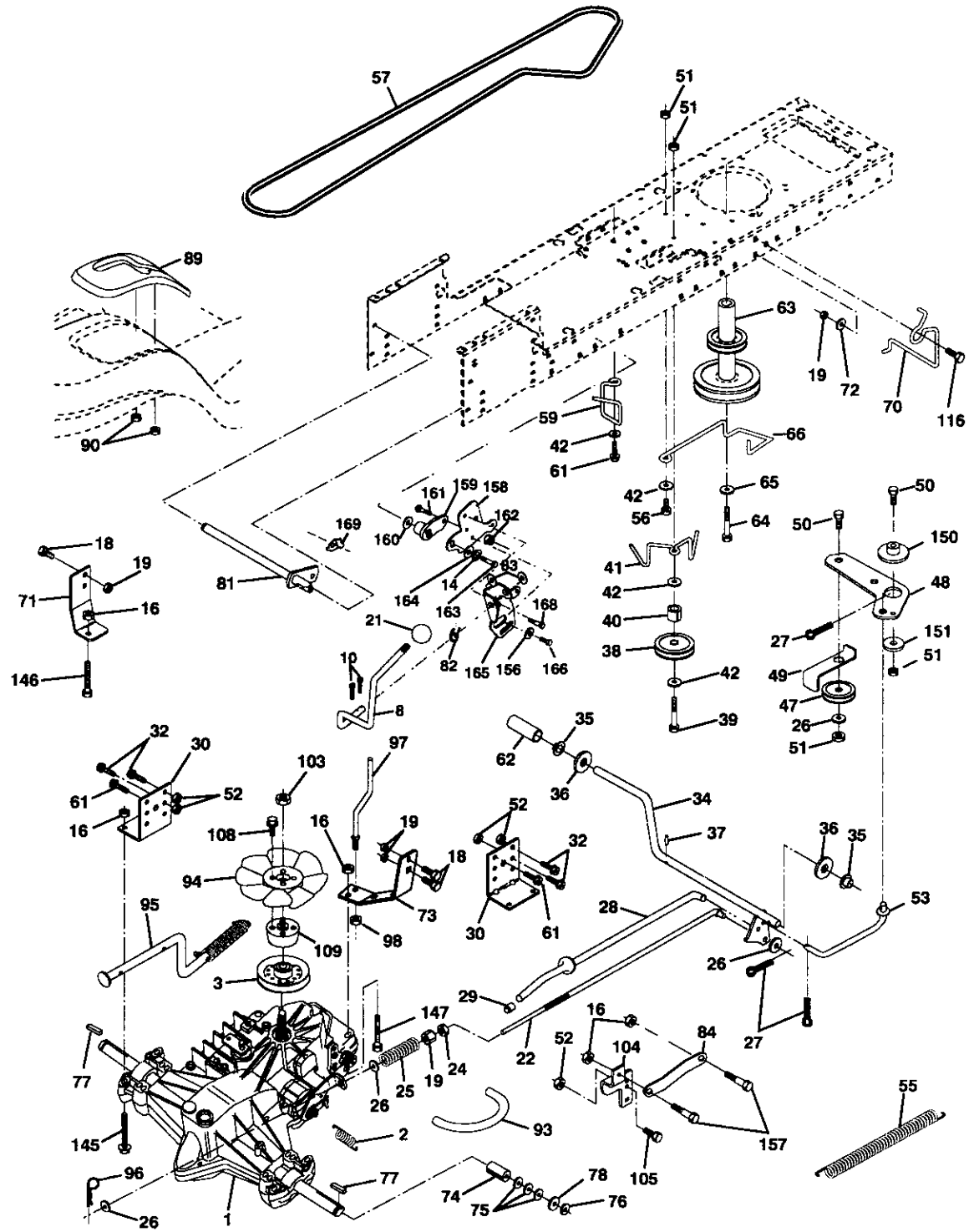

TRACTOR - - MODEL NUMBER 917.270660

GROUND DRIVE

KEY NO.	PART NO.	DESCRIPTION	KEY NO.	PART NO.	DESCRIPTION
1	-----	Transmission (See Breakdown) Hydro Gear Model 319-0500	71	141417	Strap, Torque, Lh
2	142431	Spring, Return, Brake	72	19132012	Washer 13/32 x 1-1/4 x 12 Ga.
3	144698	Pulley, Transmission	73	141418	Strap, Torque, Rh
8	165866	Rod, Shift	74	121199X	Spacer, Split
10	76020416	Pin, Cotter 1/8 x 1	75	121749X	Washer 25/32 x 1-1/4 x 16 Ga.
14	STD551125	Washer Lock 1/4	76	12000001	Ring, E
16	73800500	Nut, Lock Hex w/lns 5/16-18 UNC	77	123583X	Key, Square
18	74780616	Bolt Hex 3/8-16 UNC x 1 Gr.5	78	121748X	Washer 25/32 x 1-5/8 x 16 Ga.
19	73800600	Nut, Lock Hex w/Wsh 3/8-16 UNC	81	165595	Shaft Asm Cross
21	106933X	Knob Rd. 1/2-13 Plstc. Thds. Bik.	82	165711	Spring, Torsion
22	145627	Rod, Brake	83	19171216	Washer 17/32 x 3/4 x 16 Ga.
24	73350600	Nut	84	165816	Link Transaxle
25	106888X	Spring, Rod, Brake	89	164890X428	Console, Shift
26	19131316	Washer 13/32 x 13/16 x 16 Ga.	90	124346X	Nut Self-Thd Wshd 1/4
27	76020412	Pin, Cotter 1/8 x 3/4	93	142564	Line Fuel
28	145204	Rod, Parking Brake	94	140462	Fan 7"
29	124236X	Cap, Parking Brake	95	144643	Control Asm Bypass Hydro
30	130807	Bracket, Transmission	96	4497H	Spring, Retainer 1"
32	74760512	Bolt Hex 5/16-18 UNC x 3/4	97	144201	Keeper, Belt Rh
34	155071	Shaft, Foot Pedal	98	73510600	Nut Keps 3/8-16 UNC
35	120183X	Bearing, Nylon	103	73940800	Nut, Hex Jam Toplock 1/2-20 UNF
36	19211616	Washer	104	141421	Arm, Control Pump 500 Hydro
37	1572H	Pin, Roll	105	71070516	Bolt, Head Hex 5/16 x 18 x 1
38	131494	Pulley, Idler, Fiat	108	17541026	Screw Hex Wh Hd #10-24 x 1- 5/8
39	74760644	Bolt	109	145098	Adapter Fan
40	4470J	Spacer, Split	116	72110610	Bolt Rdhd Sq Neck 3/8-16 x 1- 1/4
41	165838	Keeper, Belt, Idler	145	74490540	Bolt Hex Flghd 5/16-18 Gr. 5
42	19131312	Washer 13/32 x 13/16 x 12 Ga.	146	74490536	Bolt Hex 5/16-18 x 2-1/4
47	127783	Pulley, Idler, V-Belt	147	74490524	Bolt Hex 5/16-18 UNC x 1-1/2
48	154407	Bellcrank Clutch Grnd Drustl	150	165850	Bushing Bellcrank Grd Drive
49	123205X	Retainer, Belt	151	19133210	Washer 13/32 x 2 x 10
50	74760624	Bolt	156	166002	Washer 5/16 x 1.0 x 1.25
51	73680600	Nut	157	153236	Bolt Shoulder 5/16-18unc-2A
52	73680500	Nut Crownlock 5/16-28	158	165589	Bracket Shift Mount
53	105710X	Link, Clutch	159	165494	Hub Tapered Flange Shift
55	105709X	Spring, Return, Clutch	160	19292016	Washer 29/32 x 1-1/4 x 16 Ga.
56	74760620	Bolt, Hex 3/8-16 UNC x 1-1/4	161	72140406	Bolt Rdhd Sqnk 1/4-20 x 3/4 Gr. 5
57	141416	V-Belt, Drive	162	73680400	Nut Crownlock 1/4-20 Unc
59	140312	Keeper, Belt, Center	163	74780416	Bolt Hex Fin 1/4-20 x 1
61	17490612	Screw, Thdrol 3/8-16 x 3/4 Type TT	164	19091010	Washer 5/8 x .281 x 10 Ga.
62	8883R	Cover, Pedal	165	165623	Bracket Pivot Lever
63	140186	Pulley, Engine	166	166880	Screw 5/16 x 1.0 x .125
64	71170764	Bolt Hex 7/16 x 4 Gr. 5	168	165492	Bolt Shoulder 5/16-18 x .561
65	10040700	Washer	169	165580	Plate Fastener Cross Shaft
66	154778	Keeper, Belt Engine Hydro			
70	134683	Guide, Belt, Mower Drive RH			

NOTE: All component dimensions given in U.S. inches
1 inch = 25.4 mm

TRACTOR -- MODEL NUMBER 917.270660
STEERING ASSEMBLY

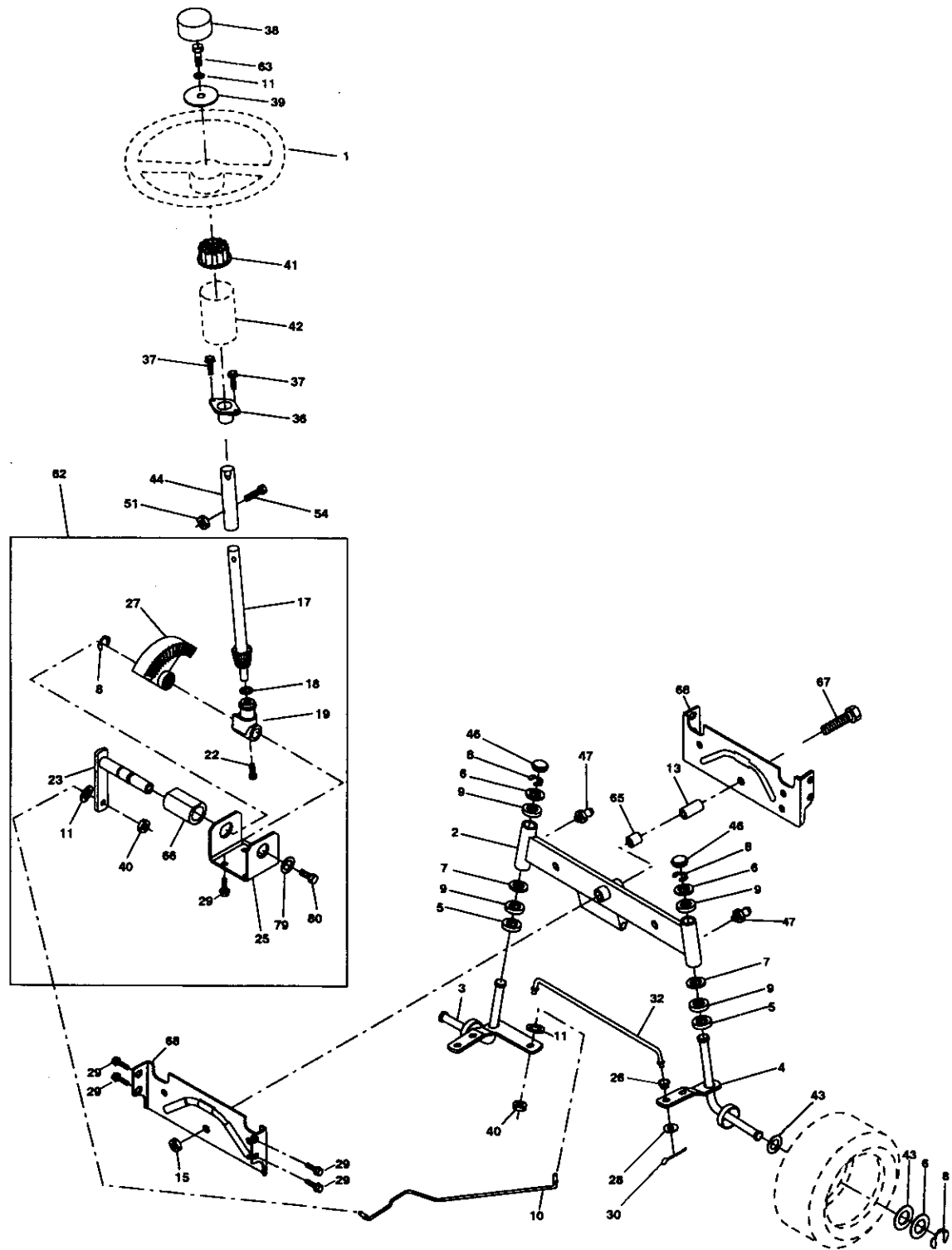

TRACTOR - - MODEL NUMBER 917.270660

STEERING ASSEMBLY

KEY NO.	PART NO.	DESCRIPTION
1	139768	Steering Wheel
2	154427	Axle Assembly STMP Dropped STL
3	156483	Spindle Assembly, L.H.
4	157473	Spindle Assembly, R.H.
5	6266H	Bearing, Race, Thrust, Hardened
6	121748X	Washer 25/32 x 1-5/8 x 16 Gauge
7	19272016	Washer 27/32 x 1-1/4 x 16 Gauge
8	12000029	Ring, Klip
9	3366R	Bearing, Steering Column
10	156438	Draglink Extended Stamped
11	STD551137	Washer, Lock
13	154779	Bearing Axle STLT/GT
15	73901000	Nut, Lock, Flange 5/8-11 UNC
17	156546	Shaft Assembly, Steering
18	57079	Washer, Thrust .515 x .750 x .033
19	160395	Support, Shaft
22	165857	Screw, Hex Wsh Hd Torx
23	165851	Pittman Shaft Assembly
25	154406	Bracket, Steering
26	126847X	Bushing, Link, Drag
27	136874	Gear, Sector
28	19131416	Washer 13/32 x 7/8 x 16 Gauge
29	17490612	Screw, Thd., Roll. 3/8-16 x 3/4
30	STD561210	Pin
32	130465	Rod, Tie
36	155099	Bushing, Steering
37	152927	Screw
38	139769	Insert, Steering Wheel
39	19133808	Washer 13/32 x 2-3/8 x 8 Gauge
40	STD541537	Gripco Nut
41	100711L	Adaptor, Steering Wheel
42	145054	Boot, Steering Shaft
43	121749X	Washer 25/32 x 1-1/4 x 16 Gauge
44	153720	Extension Shaft Steering LR.LT
46	121232X	Cap, Spindle
47	6855M	Fitting, Grease
51	STD541431	Nut Lock Hex w/Ins. 5/16-18 UNC
54	74780520	Bolt Fin Hex 5/16-18 UNC x 1-1/4
62	167902	Kit Steering Asm Service
63	STD523710	Bolt, Fin Hex 3/8-16 UNC x 1 Gr 5
65	154780	Spacer Axle
66	154404	Bearing Arm Pittman
67	74781044	Bolt, Fin Hex 5/8-11 UNC x 2-3/4
68	154429	Axle, Brace
79	19132012	Washer 13/32 x 1-1/4 x 12 Ga.
80	74950612	Bolt Hex Nylon 3/8-16 x 3/4

NOTE: All component dimensions given in U.S. inches
1 inch = 25.4 mm

ENGINE

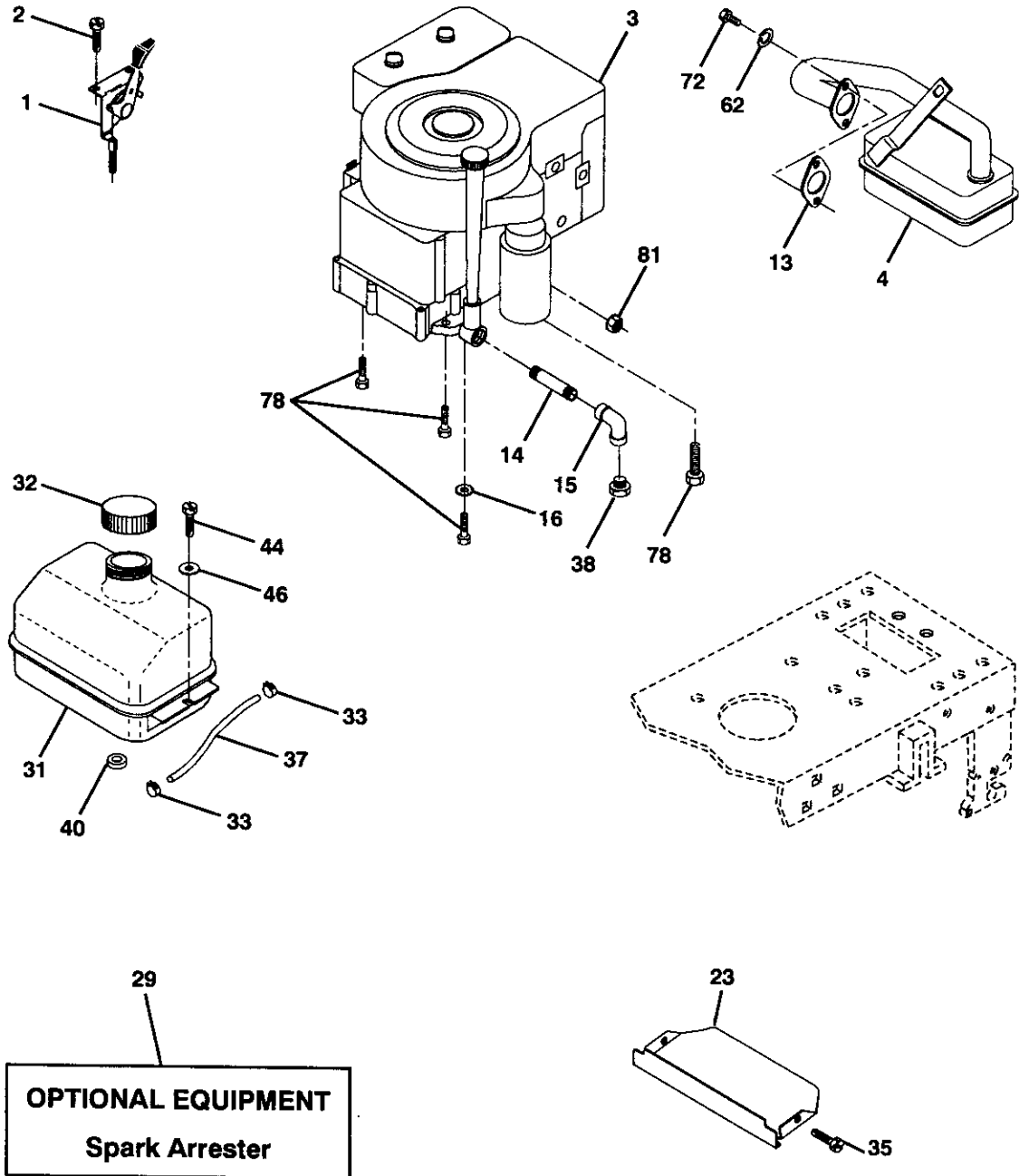

TRACTOR - - MODEL NUMBER 917.270660

ENGINE

KEY NO.	PART NO.	DESCRIPTION
1	162157	Control Throt /Ch Lh
2	17720410	Screw Hex Thd Cut 1/4-20x5/8 T
3	-----	Engine (See Breakdown) Briggs Model 28U707-1174-E1
4	137352	Muffler Exhaust B&S Lt
13	165291	Gasket 1 313 Id Tin Plated
14	13280324	Nipple Pipe 3/8 Npt X 3"
15	13200300	Elbow Std 90 Degree 3/8-18 Npt
16	STD551237	Washer Lock Ext Tooth 3/8
23	159880	Shield Browning/Debris Guard
29	137180	Arrestor Spark
31	109202X	Tank Fuel 1 25 Fr
32	158990	Cap Asm Fuel Sears Vented
33	123487X	Clamp Hose Blk
35	17490512	Screw, Thdrol 5/16-18 x 3/4 Tyt
37	137040	Line Fuel 20"
38	-----	Plug Oil Drain (See Engine Breakdown)
40	124028X	Bushing Snap Nyl Blk Fuel Line
44	17490412	Screw Hexwsh Thdrol 1/4-20x3/4
46	19091416	Washer 9/32 X 7/8 X 16ga
62	STD551131	Washer Lock Hvy Hlcl Spr 5/16
72	71070512	Screw Hexhd Cap 5/16-18x3/4
78	17490620	Screw Thdrol 3/8-16x1-1/4 Tytt
81	128861	Nut Flange 1/4-20 Starter Nut

NOTE: All component dimensions given in U.S. inches
1 inch = 25.4 mm

TRACTOR -- MODEL NUMBER 917.270660

SEAT ASSEMBLY

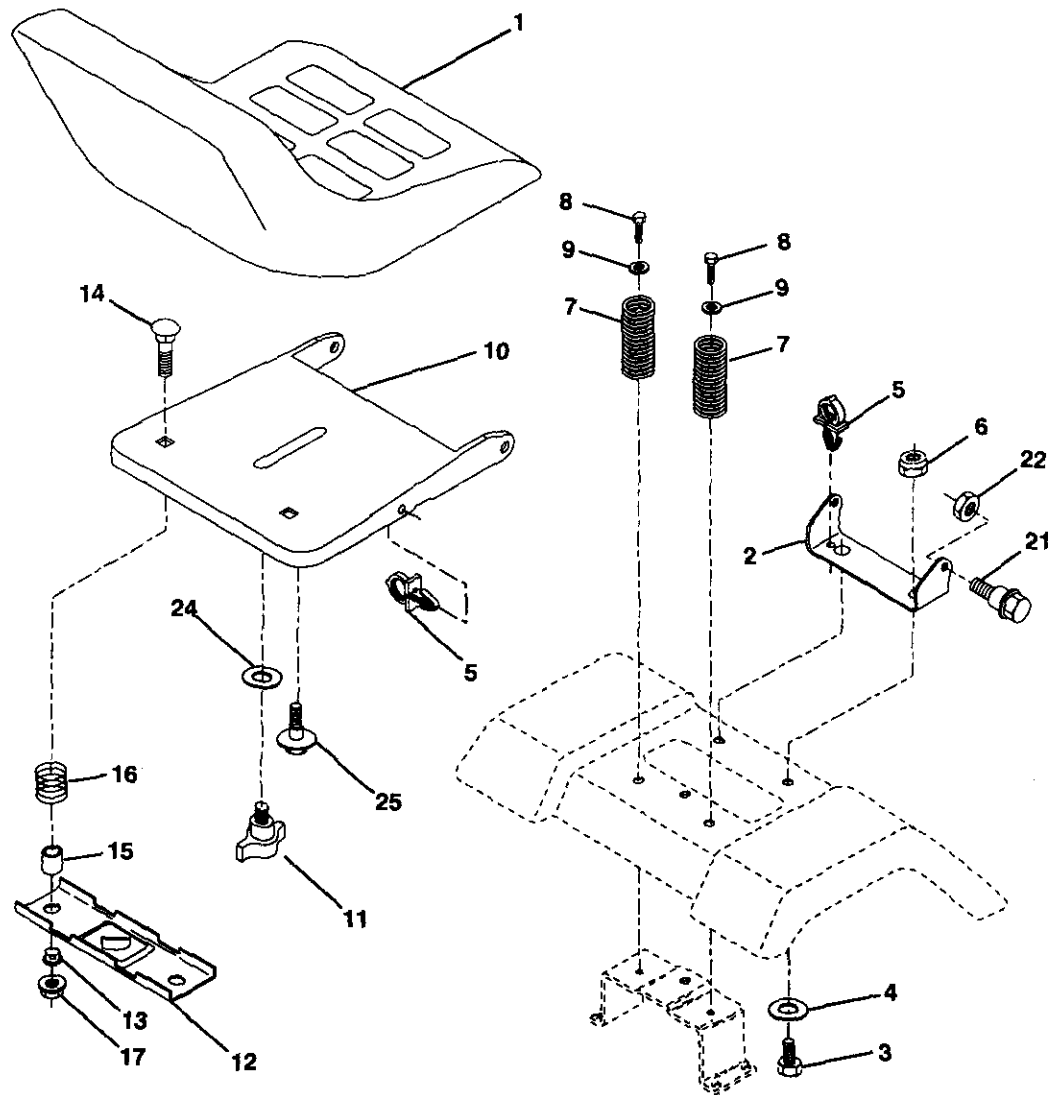

KEY NO.	PART NO.	DESCRIPTION	KEY NO.	PART NO.	DESCRIPTION
1	140122	Seat 3350 Blk/blk Craftsman	12	121246X	Bracket Pnt Mounting Switch
2	140551	Bracket Pnt Pivot Seat (blk)	13	121248X	Bushing Snap Blk Nyl 50 Id
3	STD523710	Bolt Fin Hex 3/8-16unc X 1	14	72050412	Bolt Rdhd Sht Nk 1/4-20x1-1/2
4	19131610	Washer 13/32 X 3/4 X 10 Ga	15	134300	Spacer Split 28 X 96 Zinc
5	145006	Clip Push In Hinged	16	121250X	Spring Cprsn 1 27 Blk Pnt
6	STD541437	Nut Hex Lock w/Ins 3/8-16 Unc	17	123976X	Nut Lock 1/4 Lge Flg Gr 5 Zinc
7	124181X	Spring Seat Cprsn 2 250 Blk Zi	21	153236	Bolt Shoulder 5/16-18 Unc-2A
8	17490616	Screw Thdrol 3/8-16 X 1 Ty-tt	22	STD541431	Nut Hex Lock w/Ins 5/16-18
9	19131614	Washer 13/32 X 1 X 14 Ga	24	19171912	Washer 17/32 X 1-3/16 X 12 Ga.
10	155925	Pan Pnt Seat (blk)	25	127018X	Bolt Shoulder 5/16-18 X 62
11	166369	Knob Seat Adj Wingnut			

NOTE: All component dimensions given in U.S. inches
1 inch = 25.4 mm

TRACTOR - - MODEL NUMBER 917.270660

DECALS

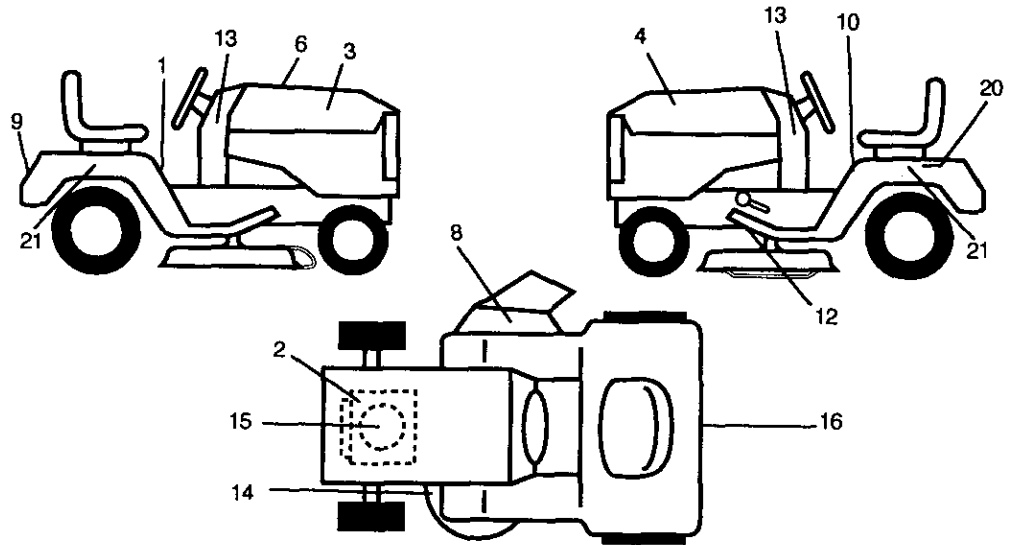

KEY NO.	PART NO.	DESCRIPTION	KEY NO.	PART NO.	DESCRIPTION
1	156811	Decal, Oper. Instr.	15	165388	Decal, Engine
2	167179	Decal, Replacement	16	142341	Decal, Drawbar Control Movement Hyd LT
3	163200	Decal, Hood, R.H.	20	149516	Decal Battery Dngr/Psn Eng
4	163202	Decal, Hood, L.H.	21	163205	Decal, Fender Sd. Wht
6	133644	Decal, Customer Maintenance	--	138311	Decal, Lift Handle
8	166887	Decal, Deck Mower EZ	--	154515	Pad Footrest LH STL
9	163204	Decal, Fender, Craftsman	--	166706	Pad Footrest RH STL
10	156439	Decal, Fender Danger	--	166707	Owner's Manual, English
12	146046	Decal, V-Belt Drive Schematic	--	165377	Owner's Manual, Spanish
13	163250	Decal, Dash Panel			
14	160396	Decal, V-Belt Schematic			

WHEELS & TIRES

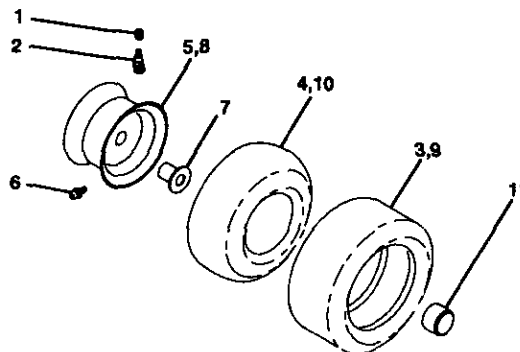

KEY NO.	PART NO.	DESCRIPTION
1	59192	Cap Valve Tire
2	65139	Stem Valve
3	106222X	Tire F Ts 15 X 6 0 - 6 Service
4	59904	Tube Inner Front #35060
5	106732X427	Rim Asm 6"front White Service
6	278H	Fitting Grease
7	9040H	Bearing Flange
8	106108X427	Rim Asm 8"rear White Service
9	106268X	Tire R Ts 18x9 5-8 Service
10	7152J	Tube Rear 9 5 X 8 Service
11	104757X	Cap Axle Blk 1 50 X 1 00
--	144334	Sealant, Tire (10 oz. tube)

NOTE: All component dimensions given in U.S. inches
1 inch = 25.4 mm

TRACTOR -- MODEL NUMBER 917.270660

LIFT ASSEMBLY

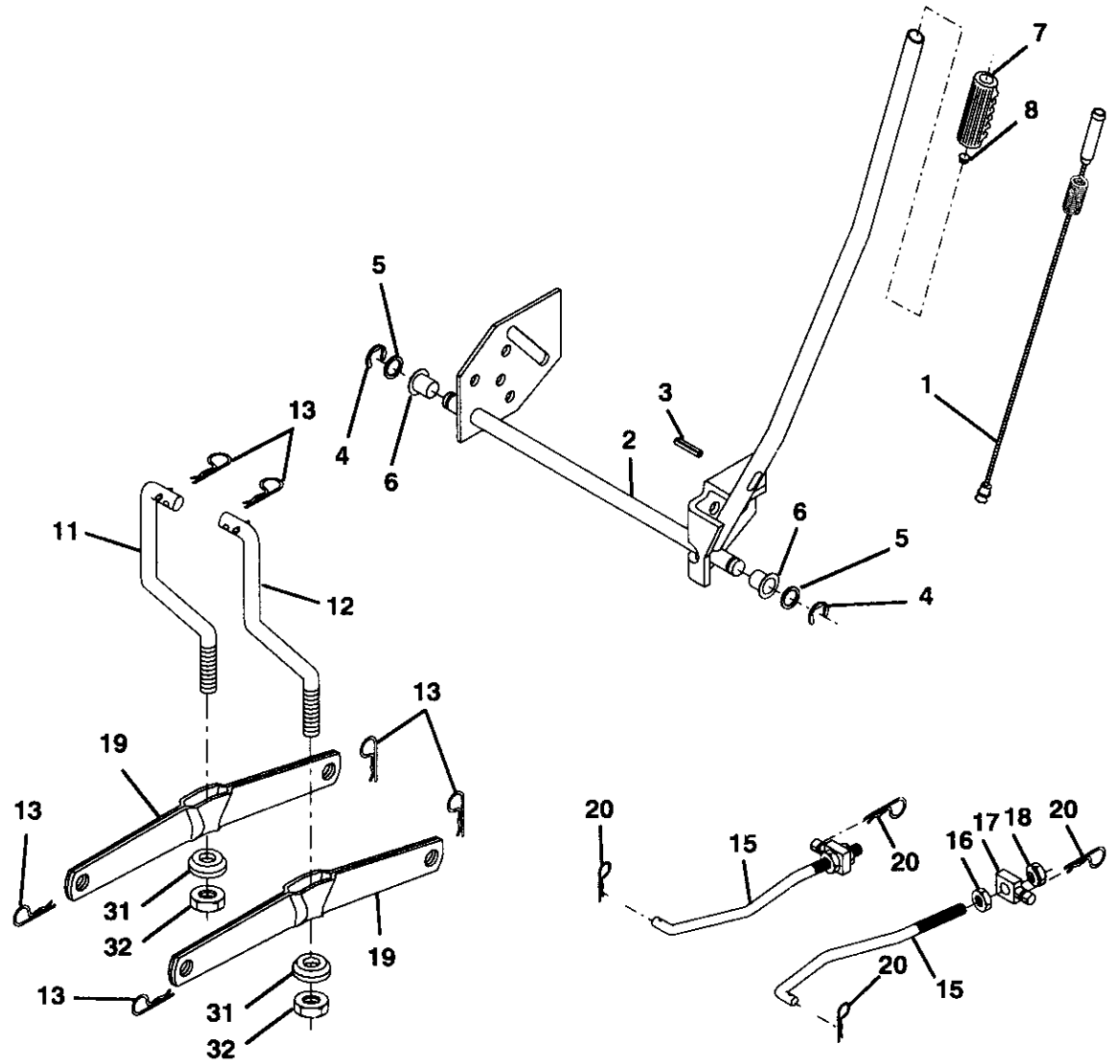

TRACTOR - - MODEL NUMBER 917.270660

LIFT ASSEMBLY

KEY NO.	PART NO.	DESCRIPTION
1	159460	Washer Asm Inner Spring W/Plunger
2	159471	Shaft Asm. Lift
3	105767X	Pin Groove
4	12000002	E Ring #5133-62
5	19211621	Washer 21/32 x 1 x 21 Ga.
6	120183X	Bearing Nylon
7	125631X	Grip Handle Fluted
8	122365X	Button Plunger Read
11	139865	Link Asm Lift L.H.
12	139866	Link Asm Lift R.H.
13	4939M	Retainer Spring
15	127218	Link Front
16	73350800	Nut Jam Hex 1/2-13 Unc
17	130171	Trunnion Blk Zinc
18	73680800	Nut Crownlock 1/2-13 Unc
19	139868	Arm Suspension Mower
20	163552	Retainer Spring
31	140302	Bearing, Pvt. Lift. Spherical
32	73540600	Nut Crownlock 3/8-24

NOTE: All component dimensions given in U.S. inches
1 inch = 25.4 mm

TRACTOR -- MODEL NUMBER 917.270660

MOWER DECK

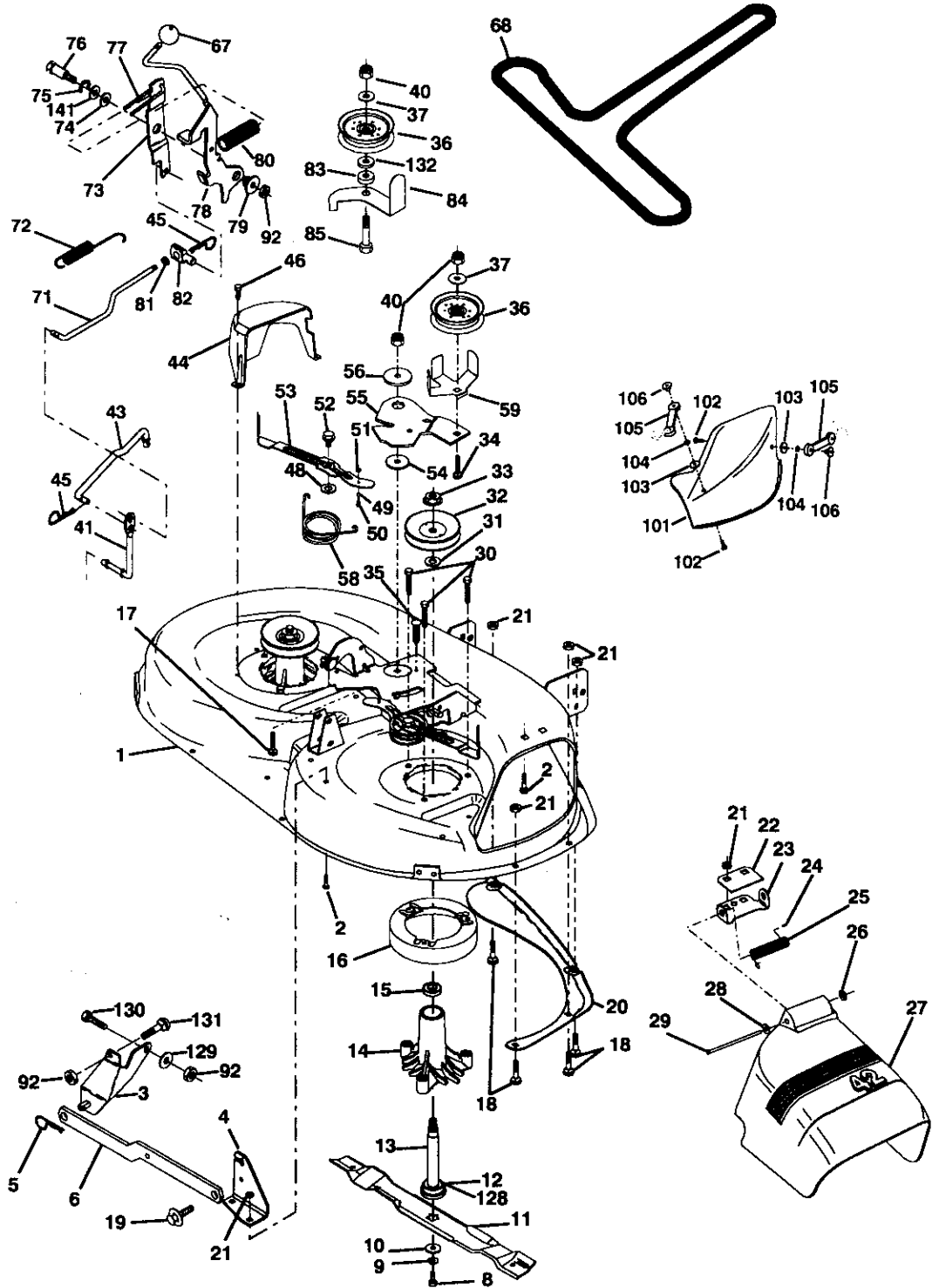

TRACTOR - - MODEL NUMBER 917.270660

MOWER DECK

KEY NO.	PART NO.	DESCRIPTION	KEY NO.	PART NO.	DESCRIPTION
1	164961	Mower Housing	51	STD541410	Locknut
2	STD533107	Bolt	52	139888	Bolt, Shoulder 5/16-18 UNC
3	138017	Bracket Assembly, Sway Bar, Front	53	131845	Arm Assembly, Pad, Brake
4	138440	Bracket Assembly, Sway Bar	54	133943	Washer, Hardened
5	STD624008	Retainer Spring	55	155046	Arm, Idler
6	130832	Arm, Suspension, Rear	56	122052X	Spacer, Retainer
8	850857	Bolt, Hex 3/8-24 x 1.25 Grade 8	58	140086	Spring, Torsion Brakes
9	STD551137	Washer, Lock	59	141043	Guard, TUV Idler
10	140296	Washer, Hardened	67	162113	Knob Custom Oval
11	134149	Blade, Mulching	68	144200	V-Belt
12	129895	Bearing, Ball	71	142427	Rod, Clutch, Primary, with Nibs
13	137645	Shaft Assembly, Mandrel, Vented (Includes Key Number 6)	72	131870	Spring, Return
14	128774	Housing, Mandrel, Vented	73	127847	Arm, Clutch, Secondary
15	110485X	Bearing, Ball, Mandrel	74	121748X	Washer 25/32 x 1-5/8 x 16 Gauge
16	140329	Stripper, Vented Mower Deck	75	12000029	Ring, Klip
17	72110610	Bolt, Carriage 3/8-16 x 1-1/4	76	128903	Bolt, Shoulder 3/8-16 UNC x 1.44
18	72140505	Bolt, Carriage 5/16-18 x 5/8	77	127845	Keeper, Spring
19	132827	Bolt, Shoulder	78	160570	Lever Asm. Clutch Pri Plm STL
20	159770	Baffle, Vortex	79	127498	Bushing, Large, Brass
21	STD541431	Nut Crownlock 5/16-18 UNC	80	153701	Spring, Mower Clutch
22	134753	Stiffener Bracket	81	73350600	Nut, Hex Jam 3/8-16 Unc
23	131267	Bracket, Deflector	82	142028	Trunnion, Adj.
24	105304X	Cap, Sleeve	83	120958X	Washer Sintered
25	123713X	Spring, Torsion, Deflector	84	156084	Keeper Belt Idler
26	110452X	Nut, Push	85	72140620	Bolt Carriage 3/8-16 x 2-1/2
27	130968	Shield, Deflector	92	STD541437	Nut
28	19111016	Washer 11/32 x 5/8 x 16 Gauge	101	136420	Mulcher Cover
29	131491	Rod, Hinge	102	71161010	Screw
30	157722	Screw Thdrol Washer Head	103	19061216	Washer #10
31	129963	Washer, Spacer	104	STD551110	Washer, Lock
32	153535	Pulley, Mandrel	105	160793	Latch Assembly, Bagger
33	137266	Nut, Toplock, Flanged	106	2029J	Nut, Weld
34	STD533717	Bolt	128	153390	Washer Felt
35	133835	Fastner, Christmas Tree	129	19131312	Washer 13/32 x 13/16 x 12 Ga.
36	131494	Pulley, Idler, Flat	130	STD523710	Bolt, Fin Hex 3/8-16 UNC x 1 Gr 5
37	19131316	Washer 13/32 x 13/16 x 16 Gauge	131	STD533710	Bolt, RDHD SQNK 3/8-16 UNC x 1
40	STD541437	Nut Crownlock 3/8-16 UNC	132	19132203	Spacer Washer 13/32 I.D. x 1-3/8 O.D. x 1/4
41	133551	Rod, Pivot, with Nibs	141	6266H	Washer Thrust .75 x 1.230
43	140063	Rod, Clutch, Secondary, with Nibs	--	130794	Mandrel Assembly (Includes Key Numbers 8-10, 12-15, 31 and 32)
44	140068	Guard, Mandrel, L.H.	--	164963	Mower Deck, Complete (Standard Deck, Order Separately Mulcher Plate Components, Key Nos. 101-106)
45	STD624003	Retainer			
46	137729	Screw, Thd. Roll 1/4-20 x 5/8			
48	133944	Washer, Hardened			
49	155066	Roller Assembly, Cam Follower			
50	131340	Bolt, Shoulder #10-24 Grade 5			

NOTE: All component dimensions given in U.S.inches
1 inch = 25.4 mm

TRACTOR -- MODEL NUMBER 917.270660
HYDRO TRANSAXLE -- MODEL NUMBER 319-0500

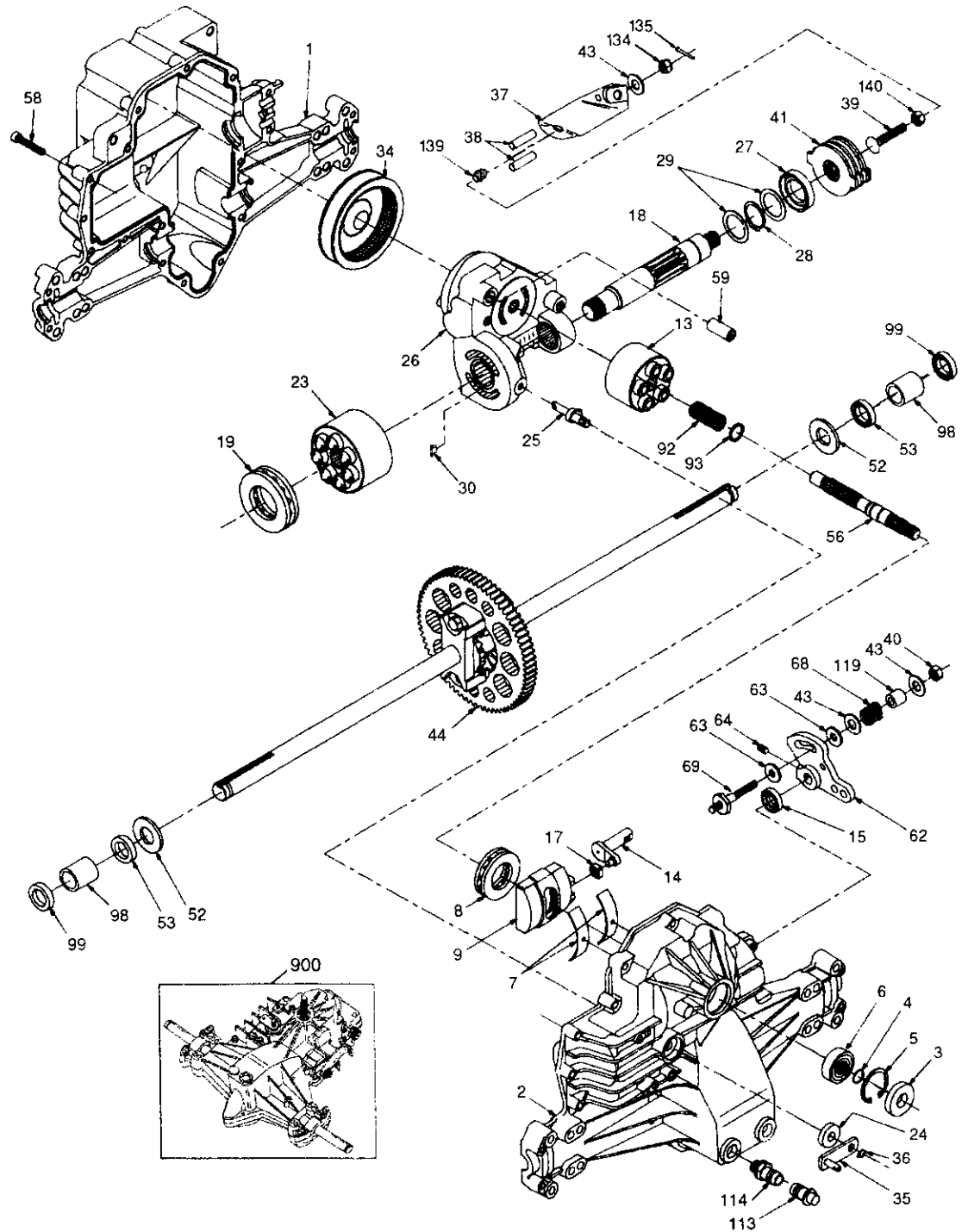

TRACTOR - - MODEL NUMBER 917.270660
HYDRO TRANSAXLE - - MODEL NUMBER 319-0500

KEY NO.	PART NO.	DESCRIPTION	KEY NO.	PART NO.	DESCRIPTION
1	142986	Housing, Lower	40	150778	Locknut, Hex 5/16-24 UNJC
2	142987	Assembly, Upper Housing	41	142958	Brake Rotor/Stator Kit
3	142932	Seal, Lip	43	142884	Washer 7/16 x 7/8 x .060
4	142928	Ring, Wire Retaining	44	142990	Differential Assembly
5	142933	Ring, Retaining	52	142991	Washer 3/4 x 1.5 x .13
6	142934	Bearing, Shaft Ball	53	142961	Seal .75 x 1.25 x .250
7	142935	Bearing, Cradle	56	142963	Shaft, Input
8	150771	Bearing, Thrust 30 x 52 x 13	58	142964	Bolt 1/4-20 x 1.38
9	142937	Swashplate, Variable	59	142965	Pin .5 OD x .43 ID x .750
13	142938	Block, Cylinder Assembly	62	142966	Arm, Control
14	142939	Arm, Trunnion	63	142967	Puck, Dampener
15	142940	Seal, Lip	64	142920	Set Screw
17	142941	Guide, Slot	68	142969	Spring
18	150772	Shaft, Motor	69	144610	Stud 5/16-24
19	150773	Bearing, Thrust 42 x 68 x 16	92	142977	Spring, Block
23	142944	Block, Cylinder Assembly	93	142978	Washer, Block Thrust
24	142945	Seal, Lip 10 x 25 x 7	98	142993	Sleeve Bearing
25	142946	Actuator, Bypass	99	142976	Seal, Wiper
26	150774	Center Section Assembly Kit	113	142917	Cap, Vent Assembly
27	142948	Seal, Lip 26 x 42 x 8	114	142918	Fitting, O-Ring Assembly
28	142949	Ring, Retaining	119	142980	Spacer
29	142950	Washer 26 x 35 x 1	134	144607	Nut, Castle 5/16-24
30	150787	Nut, Jam	135	144608	Pin, Cotter
34	142951	Oil Filter Element	139	150775	Spring, Compression
35	142952	Arm, Bypass	140	150776	Nut, Hex 5/16-24
36	142953	Ring, Retaining	900	140607	Transaxle - Complete
37	142954	Arm, Actuating			
38	142955	Pin, Actuating			
39	150777	Bolt 5/16-24 x 1-3/4			

NOTE: All component dimensions given in U.S. inches
1 inch = 25.4 mm

TRACTOR - - MODEL NUMBER 917.270660
BRIGGS & STRATTON ENGINE-MODEL NUMBER 28U707, TYPE NUMBER 1174-E1

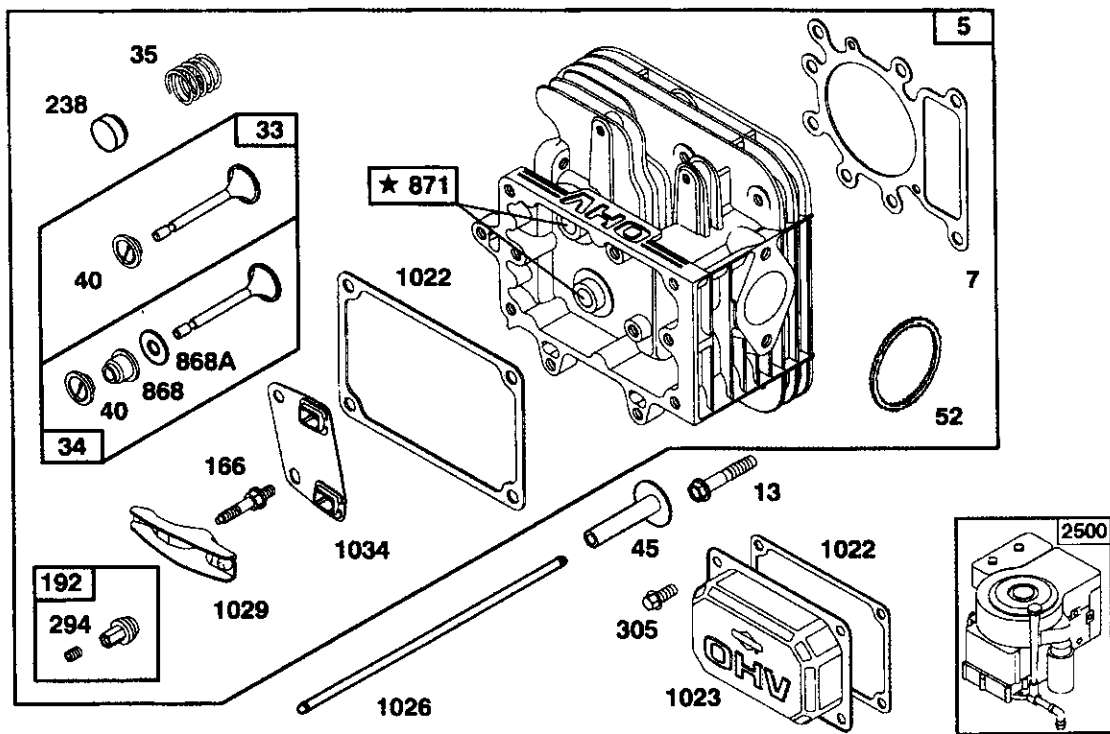
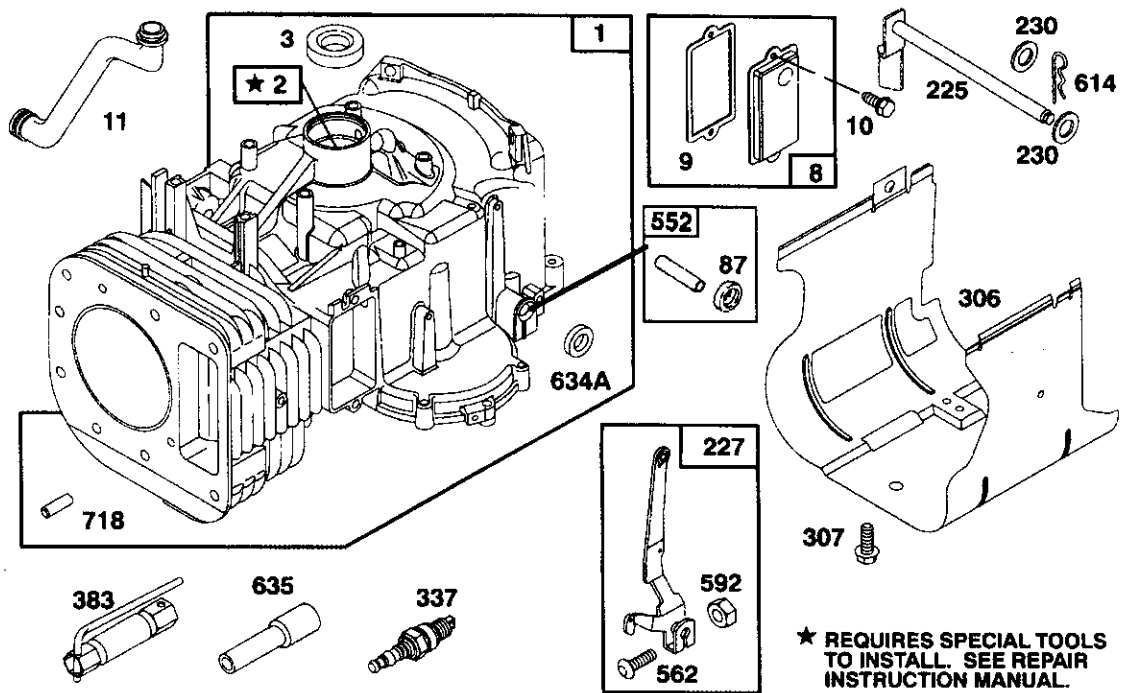

TRACTOR -- MODEL NUMBER 917.270660
BRIGGS & STRATTON ENGINE-MODEL NUMBER 28U707, TYPE NUMBER 1174-E

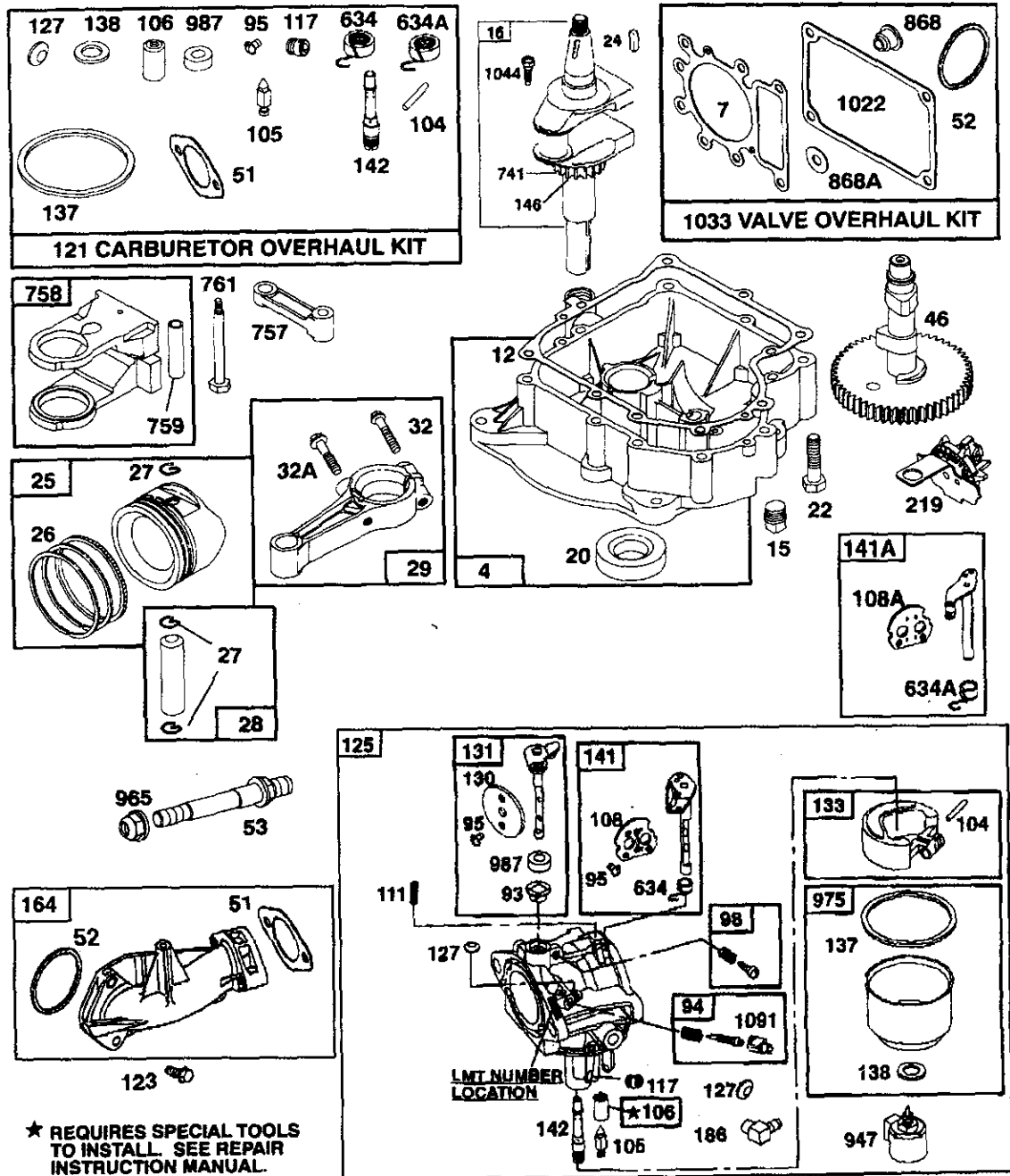

TRACTOR -- MODEL NUMBER 917.270660
BRIGGS & STRATTON ENGINE-MODEL NUMBER 28U707, TYPE NUMBER 1174-E1

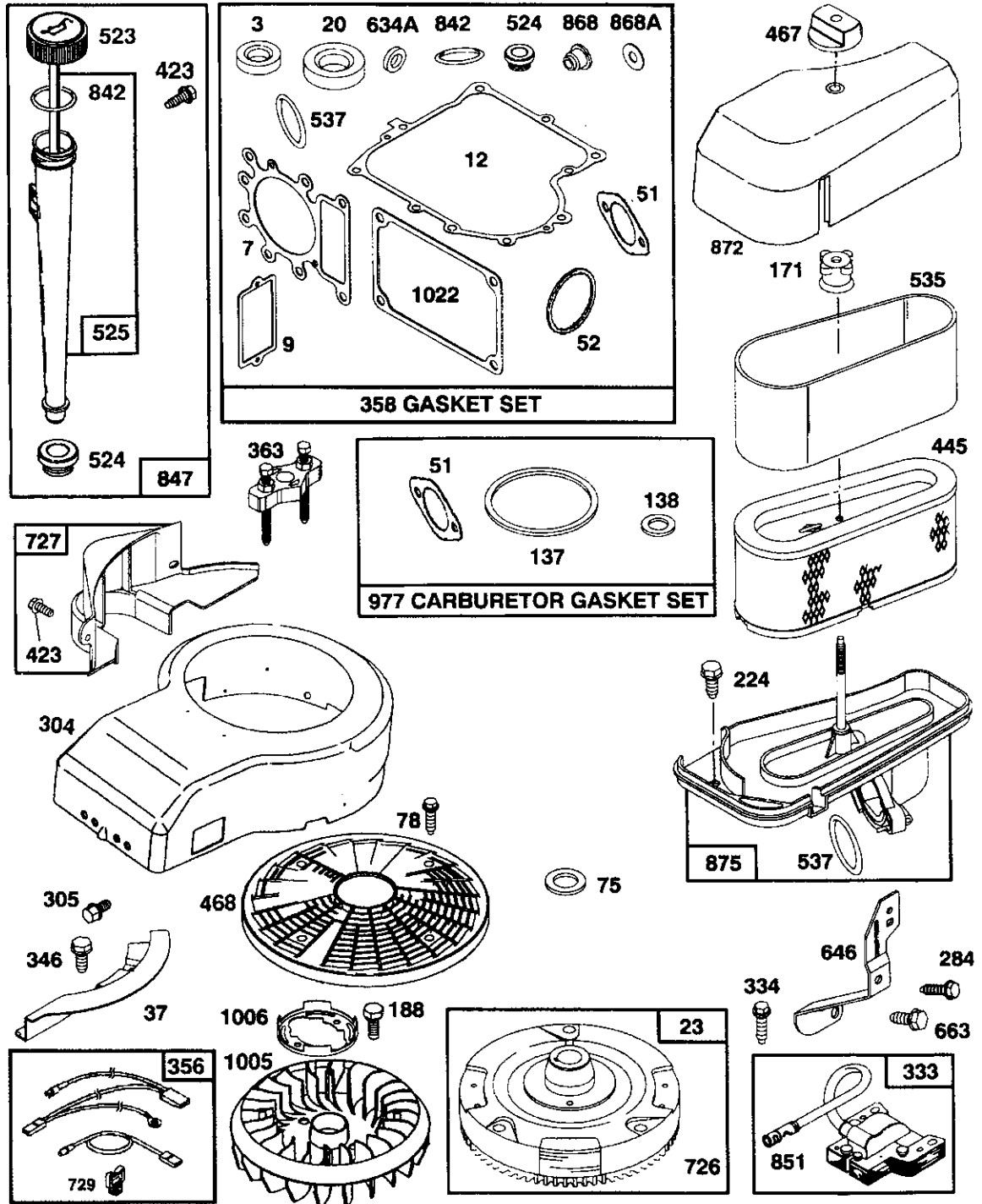

TRACTOR - - MODEL NUMBER 917.270660
BRIGGS & STRATTON ENGINE-MODEL NUMBER 28U707, TYPE NUMBER 1174-I

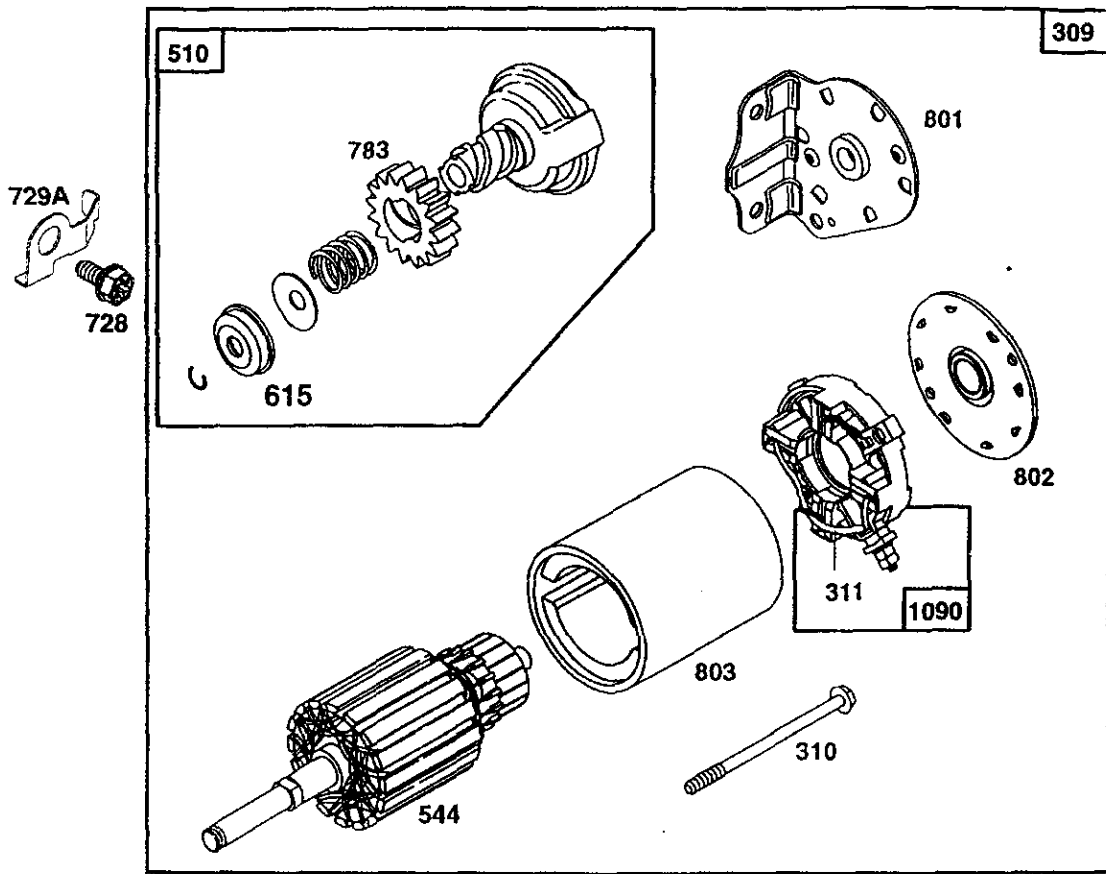
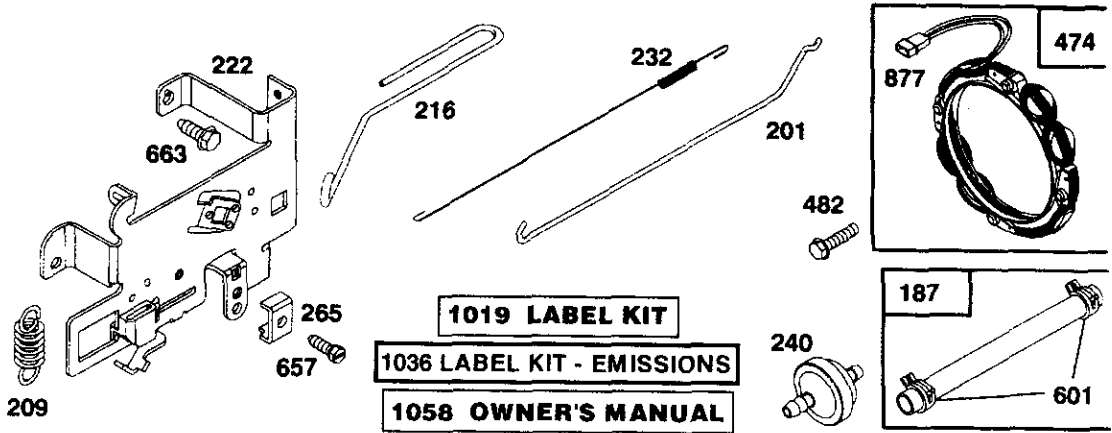

TRACTOR - - MODEL NUMBER 917.270660

BRIGGS & STRATTON ENGINE-MODEL NUMBER 28U707, TYPE NUMBER 1174-E1

KEY NO.	PART NO.	DESCRIPTION	KEY NO.	PART NO.	DESCRIPTION
1	496412	Cylinder Assembly	98	495800	Screw, Idle Speed
2	399265	Bearing, Cylinder	104	231789	** Pin, Float Hinge
3	391086	* Seal, Oil	105	231855	** Valve Float
4	494238	Base, Engine	106	231854	** Seat, Inlet Valve
5	495858	Head, Cylinder	108	224558	Valve, Choke (Lmt 153)
7	273280	*** Gasket, Cylinder Head	108A	224540	Valve, Choke (Lmt 154)
8	495735	Breather Assembly	111	262715	Spring Choke (Lmt 155)
9	27803	* Gasket, Valve Cover	117	232118	** Jet, Needle Valve (Std.)
10	94621	Screw, Sems		232119	Jet, Needle Valve (Hi-Alt.)
11	281246	Tube, Breather	121	499233	Carburetor Overhaul Kit
12	271916	* Gasket, Crankcase Cover, .015"	123	94913	Screw, Elbow Mounting
	271997	* Gasket, Crankcase Cover, .005"	125	499153	Carburetor Assembly
	271996	* Gasket, Crankcase Cover, .009"	127	- - -	** Plug, Welch (Sold in Kit Only)
13	94728	Screw, Cylinder Head	130	224539	Valve, Throttle
15	94239	Plug, Oil Drain	131	494379	Shaft and Lever, Throttle
16	498971	Crankshaft	133	494381	Float, Carburetor
	94196	Timing Gear Key	137	281165	**** Gasket, Float Bowl
20	291675	* Seal, Oil	138	281164	**** Washer, Bowl
22	94624	Screw, Sems, Base Mounting	141	495097	Choke, Shaft Kit (Choke-A-Matic)
23	492326	Flywheel and Ring Gear Assembly, Magneto	141A	495931	Choke, Shaft Kit (Choke-A-Matic)
24	222698	Key, Flywheel	142	232117	** Nozzle, Carburetor
25	495860	Piston Assembly, Standard Size	146	94196	Key, Timing Gear
	495977	Piston Assembly, .010" Oversize	164	214047	Elbow, Carburetor
	495978	Piston Assembly, .020" Oversize	166	94555	Stud, Rocker Arm
	495979	Piston Assembly, .030" Oversize	171	281051	Nut, Air Cleaner Mounting
26	495854	Ring Set, Piston, Standard Size	186	493496	Connector, Hose
	495852	Ring Set, Piston, .010" Oversize	187	298099	Line, Fuel (Cut to Suit)
	495851	Ring Set, Piston, .020" Oversize	188	94627	Screw, Sems
	495855	Ring Set, Piston, .030" Oversize	192	492160	Screw Assembly, Rocker Arm
27	263129	Lock, Piston Pin	201	262767	Link, Governor
28	498319	Pin Assy., Piston, Standard Size	209	260695	Spring, Governor
	498320	Pin Assy., Piston, .005" Oversize	216	262766	Link, Choke
29	494504	Rod Assembly, Connecting	219	490815	Gear, Governor
	495490	Rod Assembly, Connecting, .020" Undersize Crankpin Bore	222	495611	Plate, Governor Control
32	94695	Screw, Hex Washer Head, 1-5/8	224	94905	Screw, Sems, Air Cleaner
32A	94648	Screw, Hex Washer Head, 1-5/8	225	495157	Crank, Governor
33	495856	Valve, Exhaust	227	493935	Lever Assembly, Governor
34	495857	Valve, Intake	230	94742	Washer, Governor Crank
35	262811	Spring, Valve	232	262785	Spring, Governor Link
37	224502	Guard, Flywheel	238	262836	Cap, Valve
40	224641	Retainer, Valve Spring	240	394358	Filter, Fuel (In Fuel Line)
45	262411	Tappet, Valve	265	221535	Clamp, Casing
46	496884	Gear, Cam	284	94704	Screw, Hex Head
51	272465	**** Gasket, Carburetor (Carburetor to Elbow)	*		Included in Gasket Set (495993)
52	272569	*** Gasket, Carburetor (Elbow to Cylinder)	**		Included in Carburetor Kit (499233)
53	94637	Stud, Carburetor Mounting	***		Included in both Gasket Set (495993) and Valve Overhaul Kit (495992)
75	225136	Washer, Spring	****		Included in Gasket Set (495993), Carburetor Kit (499233) and Carburetor Gasket Set (494385)
78	94832	Screw, Pan Head			
87	491323	* Seal, Governor Shaft			
93	281346	Bushing, Throttle Shaft			
94	498030	Valve, Needle			
95	94098	** Screw, Throttle			

NOTE: All component dimensions given in U.S. inches
1 inch = 25.4 mm

TRACTOR - - MODEL NUMBER 917.270660
BRIGGS & STRATTON ENGINE-MODEL NUMBER 28U707, TYPE NUMBER 1174-I

KEY NO.	PART NO.	DESCRIPTION	KEY NO.	PART NO.	DESCRIPTION
294	810068	Screw, Set	757	213998	Link, Counterweight
304	496280	Housing, Blower	758	399891	Counterweight Assembly
305	94786	Screw, Hex, Head, Blower Housing Mounting	759	298909	Pin, Counterweight
306	225020	Shield, Cylinder	761	94593	Screw, Counterweight
307	94930	Screw, Cylinder Shield	783	280104	Gear, Starter
309	497595	Motor, Starter	801	394856	Cap, Drive
310	497602	Bolt, Thru	802	497605	Cap, End
311	497608	Brush Set	803	497604	Housing, Starter
333	495859	Armature, Magneto	842	270920	* Seal, Oil Filler Cap
334	94731	Screw, Sems, Armature Mounting	847	496415	Fill Group, Oil
337	491055	Plug, Spark	851	224110	Terminal, Ignition Cable
346	93705	Screw, Hex Head	868	494435	*** Seal Assembly, Valve
356	497708	Wire Assembly	868A	272610	*** Gasket, Valve
358	495993	Gasket Set	871	262835	Bushing, Guide (Intake & Exhaust)
363	19203	Puller, Flywheel	872	281361	Cover, Air Cleaner
383	89838	Wrench, Spark Plug	875	495862	Body, Air Cleaner
423	94903	Screw, Sems	877	393456	Diode and Connector Assemb
445	493909	Cartridge, Air Cleaner	947	497672	Solenoid
467	493903	Knob, Air Cleaner	965	94010	Nut, Hex
468	494439	Screen, Flush Rotating	975	495933	Bowl Assembly, Carburetor
474	393474	Stator, Alternator	977	494385	Carburetor Gasket Set
482	93621	Screw, Sems	987	281166	** Seal, Throttle Shaft
503	806000	Strap, Starter	1005	281400	Fan, Flywheel
510	497606	Drive, Starter	1006	224413	Retainer, Fan
523	495230	Cap and Dipstick, Oil Filler	1019	496758	Label Kit
524	281370	* Seal, Filler Tube	1022	272475	*** Gasket, Cover
525	496113	Tube, Oil Filler	1023	224552	Cover, Rocker Arm
535	272403	Element, Filter	1026	494432	Rod, Push, Intake
537	281106	* O-Ring, Air Cleaner		495136	Rod, Push, Exhaust
544	497603	Armature, Starter	1029	224554	Arm, Rocker
552	491986	Bushing, Governor Crank	1033	495992	Valve Overhaul Kit
562	94907	Bolt, Carriage	1034	495248	Guide Assembly, Push Rod
592	231978	Nut, Hex	1036	499364	Label Kit, Emissions
601	93053	Clamp, Fuel Pipe	1044	94673	Screw, Hex Head
614	93306	Pin, Cotter	1054	270723	Tie, Cable
615	263080	Retainer	1058	272623	Manual, Owner's
618	262803	Spring, Choke Return	1090	497607	Retainer, Brush
634	494453	** Seal, Spring Assy.	1091	281364	Cap, Limiter
634A	494455	** Seal, Spring Assy.	2500	28N707-1026	Replacement Engine
635	280872	Boot, Spark Plug	— —	496050	Replacement Shortblock
646	224546	Brace, Air Cleaner			RPM Settings: Low: 1650-1850, High: 3200-3400
657	94906	Screw, Sems			* Included in Gasket Set (495993)
663	94620	Screw, Self-Tapping			** Included in Carburetor Kit (499233)
718	230192	Pin, Dowel			*** Included in both Gasket Set (495993) and Valve Overhaul Kit (495992)
726	399676	Gear, Ring (Includes Mounting Hardware)			**** Included in Gasket Set (495993), Carburetor Kit (499233) and Carburetor Gasket Set (494385)
727	490324	Cover, Starter			
728	94951	Screw, Torx®			
729	281390	Clip, Wire			
729A	225170	Retainer, Wire			
741	262932	Gear, Timing			

NOTE: All component dimensions given in U.S. inches
1 inch = 25.4 mm

SUGGESTED GUIDE FOR SIGHTING SLOPES FOR SAFE OPERATION

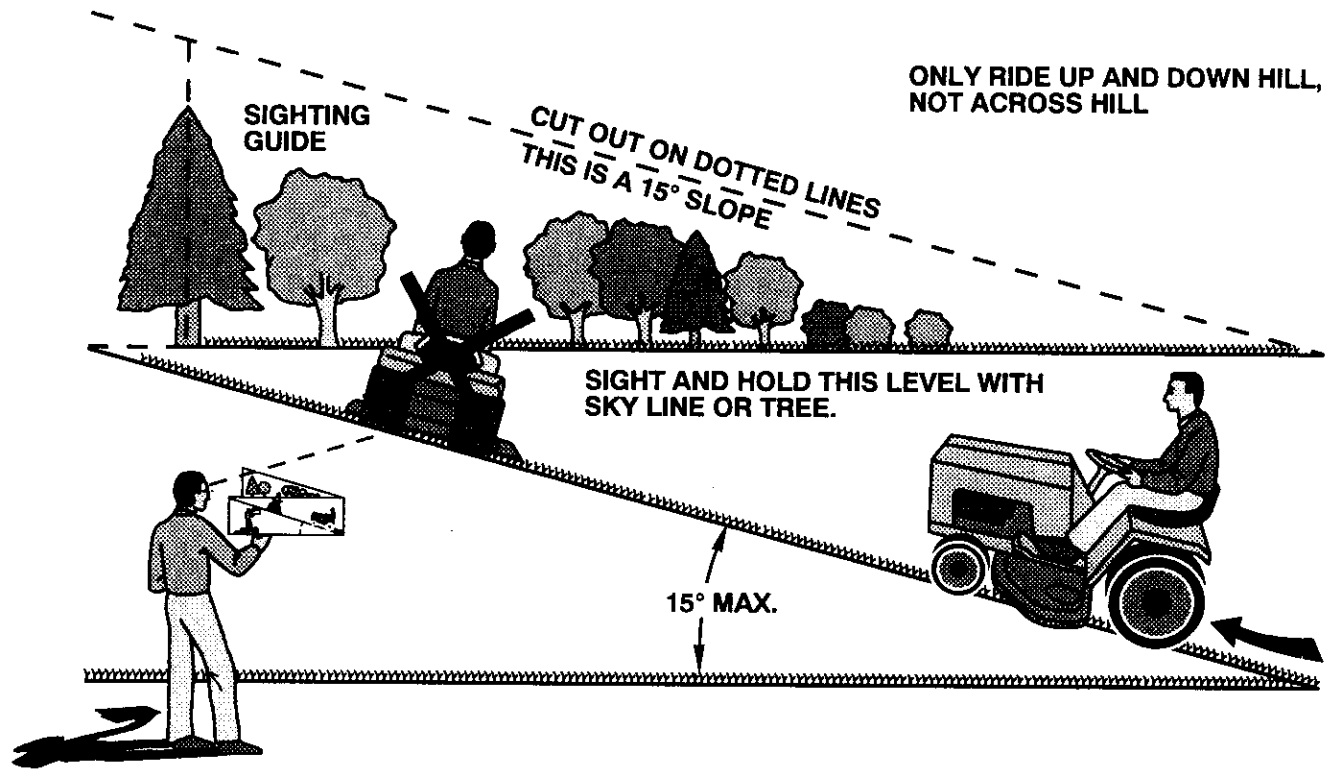

59

 **Operate your Tractor up and down the face of slopes (not greater than 15°), never across the face. Make turns gradually to prevent tipping or loss of control. Exercise extreme caution when changing direction on slopes.**

Downloaded from <https://www.manualslib.com>

For in-home major brand repair service:

Call 24 hours a day, 7 days a week

1-800-4-MY-HOMESM (1-800-469-4663)

Para pedir servicio de reparación a domicilio

1-800-676-5811

In Canada for all your service and parts needs call

Au Canada pour tout le service ou les pièces

1-800-665-4455

For the repair or replacement parts you need:

Call 6 am - 11 pm CST, 7 days a week

PartsDirectSM

1-800-366-PART (1-800-366-7278)

Para ordenar piezas con entrega a domicilio

1-800-659-7084

**For the location of a Sears Parts and Repair Center
in your area:**

Call 24 hours a day, 7 days a week

1-800-488-1222

**For information on purchasing a Sears Maintenance
Agreement or to inquire about an existing Agreement:**

Call 9 am - 5 pm, Monday - Saturday

1-800-827-6655



Free Manuals Download Website

<http://myh66.com>

<http://usermanuals.us>

<http://www.somanuals.com>

<http://www.4manuals.cc>

<http://www.manual-lib.com>

<http://www.404manual.com>

<http://www.luxmanual.com>

<http://aubethermostatmanual.com>

Golf course search by state

<http://golfingnear.com>

Email search by domain

<http://emailbydomain.com>

Auto manuals search

<http://auto.somanuals.com>

TV manuals search

<http://tv.somanuals.com>