

# Owner's Manual

## **CRAFTSMAN<sup>®</sup>** **6.0 HORSEPOWER** **22" REAR DISCHARGE** **ROTARY LAWN MOWER**

Model No.  
917.387402

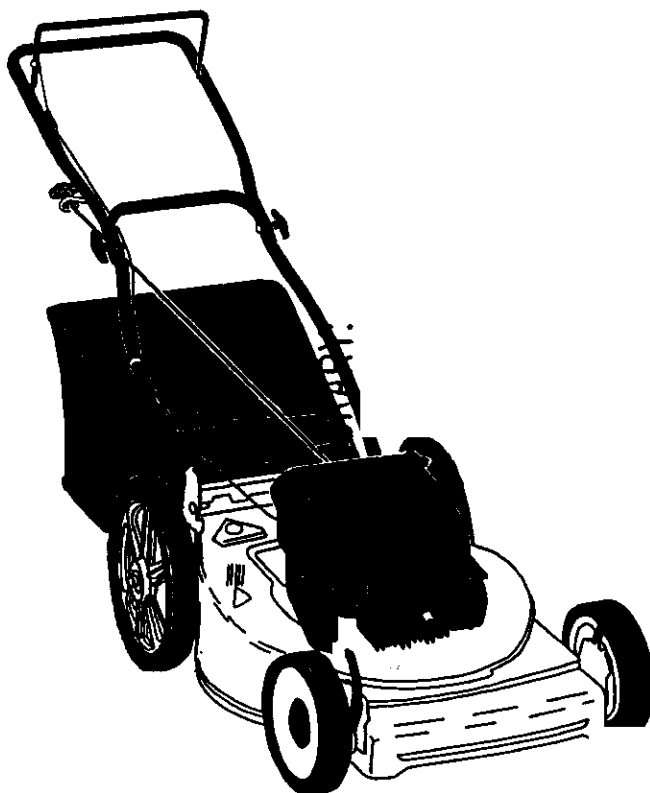

- **Safety**
- **Assembly**
- **Operation**
- **Maintenance**
- **Español**
- **Repair Parts**

### **CAUTION:**

Read and follow all  
Safety Rules and Instructions  
before operating this equipment

Sears, Roebuck and Co., Hoffman Estates, IL 60179

## TABLE OF CONTENTS

Warranty	2	Product Specifications	11
Safety Rules	2	Service and Adjustments	13
Assembly	4	Storage	15
Operation	6	Troubleshooting	16
Maintenance Schedule	10	Repair Parts	34
Maintenance	10	Parts Ordering	Back Cover

## WARRANTY

### LIMITED TWO YEAR WARRANTY ON CRAFTSMAN POWER MOWER

For two years from date of purchase, when this Craftsman Lawn Mower is maintained, lubricated, and tuned up according to the operating and maintenance instructions in the owner's manual, Sears will repair free of charge any defect in material or workmanship. If this Craftsman Lawn Mower is used for commercial or rental purposes, this warranty applies for only 90 days from the date of purchase.

This Warranty does not cover:

- Expendable items which become worn during normal use, such as rotary mower blades, blade adapters, belts, air cleaners and spark plug.
- Repairs necessary because of operator abuse or negligence, including bent crankshafts and the failure to maintain the equipment according to the instructions contained in the owner's manual.

Warranty service is available by returning the Craftsman power mower to the nearest Sears Service Center/Department in the United States. This warranty applies only while this product is in use in the United States.

This Warranty gives you specific legal rights, and you may also have other rights which vary from state to state.

SEARS, ROEBUCK AND CO., D/817 WA, HOFFMAN ESTATES, ILLINOIS 60179

## SAFETY RULES

Safety standards require operator presence controls to minimize the risk of injury. Your unit is equipped with such controls. Do not attempt to defeat the function of the operator presence controls under any circumstances.

### TRAINING:

- Read this operator's manual carefully. Become familiar with the controls and know how to operate your mower properly. Learn how to quickly stop mower.
- Do not allow children to use your mower. Never allow adults to use mower without proper instructions.
- Keep the area of operation clear of all persons, especially small children and pets.
- Use mower only as the manufacturer intended and as described in this manual.

- Do not operate mower if it has been dropped or damaged in any manner. Always have damage repaired before using your mower.
- Do not use accessory attachments that are not recommended by the manufacturer. Use of such attachments may be hazardous.
- The blade turns when the engine is running.

### PREPARATION:

- Always thoroughly check the area to be mowed and clear it of all stones, sticks, wires, bones, and other foreign objects. These objects will be thrown by the blade and can cause severe injury.
- Always wear safety glasses or eye shields when starting and while using your mower.

- Dress properly. Do not operate mower when barefoot or wearing open sandals. Wear only solid shoes with good traction when mowing.
- Check fuel tank before starting engine. Do not fill gas tank indoors, when the engine is running or when the engine is hot. Allow the engine to cool for several minutes before filling the gas tank. Clean off any spilled gasoline before starting the engine.
- Always make wheel height adjustments before starting your mower. Never attempt to do this while the engine is running.
- Mow only in daylight or good artificial light.
- Never cut grass by pulling the mower towards you. Mow across the face of slopes, never up and down or you might lose your footing. Do not mow excessively steep slopes. Use caution when operating the mower on uneven terrain or when changing directions — maintain good footing.
- Never operate your mower without proper guards, plates, grass catcher or other safety devices in place.

### **MAINTENANCE AND STORAGE:**

- OPERATION:**
- Keep your eyes and mind on your mower and the area being cut. Do not let other interests distract you.
  - Do not mow wet or slippery grass. Never run while operating your mower. Always be sure of your footing — keep a firm hold on the handles and walk.
  - Do not put hands or feet near or under rotating parts. Keep clear of the discharge opening at all times.
  - Always stop the engine whenever you leave or are not using your mower, or before crossing driveways, walks, roads, and any gravel—covered areas.
  - Never direct discharge of material toward bystanders nor allow anyone near the mower while you are operating it.
  - Before cleaning, inspecting, or repairing your mower, stop the engine and make absolutely sure the blade and all moving parts have stopped. Then disconnect the spark plug wire and keep it away from the spark plug to prevent accidental starting.
  - Do not continue to run your mower if you hit a foreign object. Follow the procedure outlined above, then repair any damage before restarting and operating you mower.
  - Do not change the governor settings or overspeed the engine. Engine damage or personal injury may result.
  - Do not operate your mower if it vibrates abnormally. Excessive vibration is an indication of damage; stop the engine, safely check for the cause of vibration and repair as required.
  - Do not run the engine indoors. Exhaust fumes are dangerous.
  - Check the blade and the engine mounting bolts often to be sure they are tightened properly.
  - Check all bolts, nuts and screws at frequent intervals for proper tightness to be sure mower is in safe working condition.
  - Keep all safety devices in place and working.
  - To reduce fire hazard, keep the engine free of grass, leaves or excessive grease and oil.
  - Check grass catcher often for deterioration and wear and replace worn bags. Use only replacement bags that are recommended by and comply with specifications of the manufacturer of your mower.
  - Always keep a sharp blade on your mower.
  - Allow engine to cool before storing in any enclosure.
  - Never store mower with fuel in the tank inside a building where fumes may reach an open flame or an ignition source such as a hot water heater, space heater, clothes dryer, etc.

**▲CAUTION:** Always disconnect spark plug wire and place wire where it cannot contact spark plug in order to prevent accidental starting when setting up, transporting, adjusting or making repairs.





**▲WARNING:** The engine exhaust from this product contains chemicals known to the State of California to cause cancer, birth defects, or other reproductive harm.

## ACCESSORIES



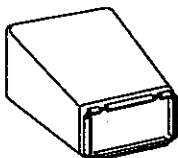

These accessories were available when this lawn mower was produced. They are also available at most Sears retail outlets and service centers. Most Sears stores can also

order repair parts for you, when you provide the model number of your lawn mower. Some of these accessories may not apply to your lawn mower.

### LAWN MOWER PERFORMANCE

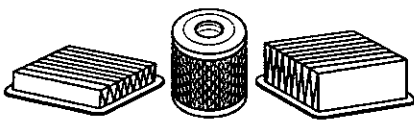
 <p><b>CLIPPING DEFLECTOR FOR REAR DISCHARGE LAWN MOWERS</b></p>	 <p><b>MULCHER KITS</b></p>	 <p><b>STABILIZER</b></p>
 <p><b>GRASS CATCHERS FOR REAR DISCHARGE LAWN MOWERS</b></p>	 <p><b>GRASS CATCHERS FOR SIDE DISCHARGE LAWN MOWERS</b></p>	 <p><b>GAS CANS</b></p>

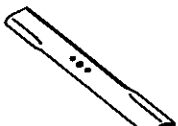
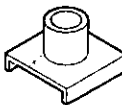
### LAWN MOWER MAINTENANCE

 <p><b>MUFFLERS</b></p>	 <p><b>AIR FILTERS</b></p>	 <p><b>SPARK PLUGS</b></p>		
 <p><b>BELTS</b></p>	 <p><b>BLADES</b></p>	 <p><b>BLADE ADAPTERS</b></p>	 <p><b>WHEELS</b></p>	 <p><b>ENGINE OIL</b></p>

## ASSEMBLY

Read these instructions and this manual in its entirety before you attempt to assemble or operate your new lawn mower. Your new lawn mower has been assembled at the factory with the exception of those parts left unassembled for shipping purposes. All parts such as nuts, washers, bolts, etc., necessary to complete the assembly have been placed in the parts bag. To ensure safe and proper operation of your lawn mower, all parts and hardware you assemble must be tightened securely. Use the correct tools as necessary to ensure proper tightness.

### TO REMOVE LAWN MOWER FROM CARTON

- Remove loose parts included with mower.
- Cut down two end corners of carton and lay end panel down flat.
- Remove all packing materials except padding between upper and lower

handle and padding holding operator presence control bar to upper handle.

- Roll lawn mower out of carton and check carton thoroughly for additional loose parts.

### HOW TO SET UP YOUR LAWN MOWER

#### TO UNFOLD HANDLE

**IMPORTANT:** Unfold handles carefully so as not to pinch or damage control cables.

- Raise handles until lower handle section locks into place in mowing position.
- Remove protective padding, raise upper handle section into place on lower handles and tighten both handle knobs.
- Remove handle padding holding operator presence control bar to upper handle.
- Your lawn mower handle can be adjusted for your mowing comfort. Refer to "Adjust Handle" in the Service and Adjustment section of this manual.

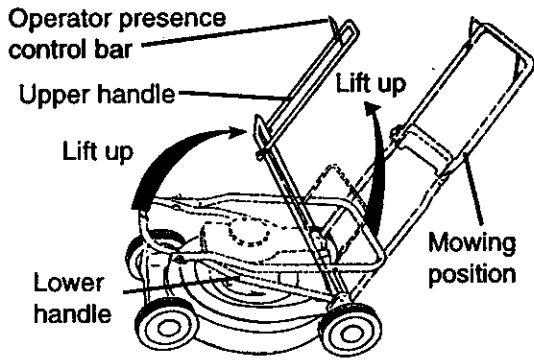

## TO INSTALL ATTACHMENTS

Your lawn mower was shipped ready to be used as a mulcher. To convert to bagging or discharging:

- Open rear door and remove mulcher plug. Store mulcher plug in a safe place.
- You can now install catcher or optional clipping deflector.
- To return to mulching operation, install mulcher plug into discharge opening of mower.

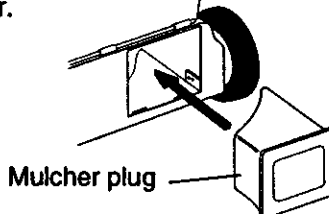

**▲CAUTION:** Do not run your lawn mower without mulcher plug in place or approved clipping deflector or grass catcher in place. Never attempt to operate the lawn mower with the rear door removed or propped open.

# OPERATION

## KNOW YOUR LAWN MOWER

READ THIS OWNER'S MANUAL AND SAFETY RULES BEFORE OPERATING YOUR LAWN MOWER. Compare the illustrations with your lawn mower to familiarize yourself with the location of various controls and adjustments. Save this manual for future reference.

These symbols may appear on your lawn mower or in literature supplied with the product. Learn and understand their meaning.

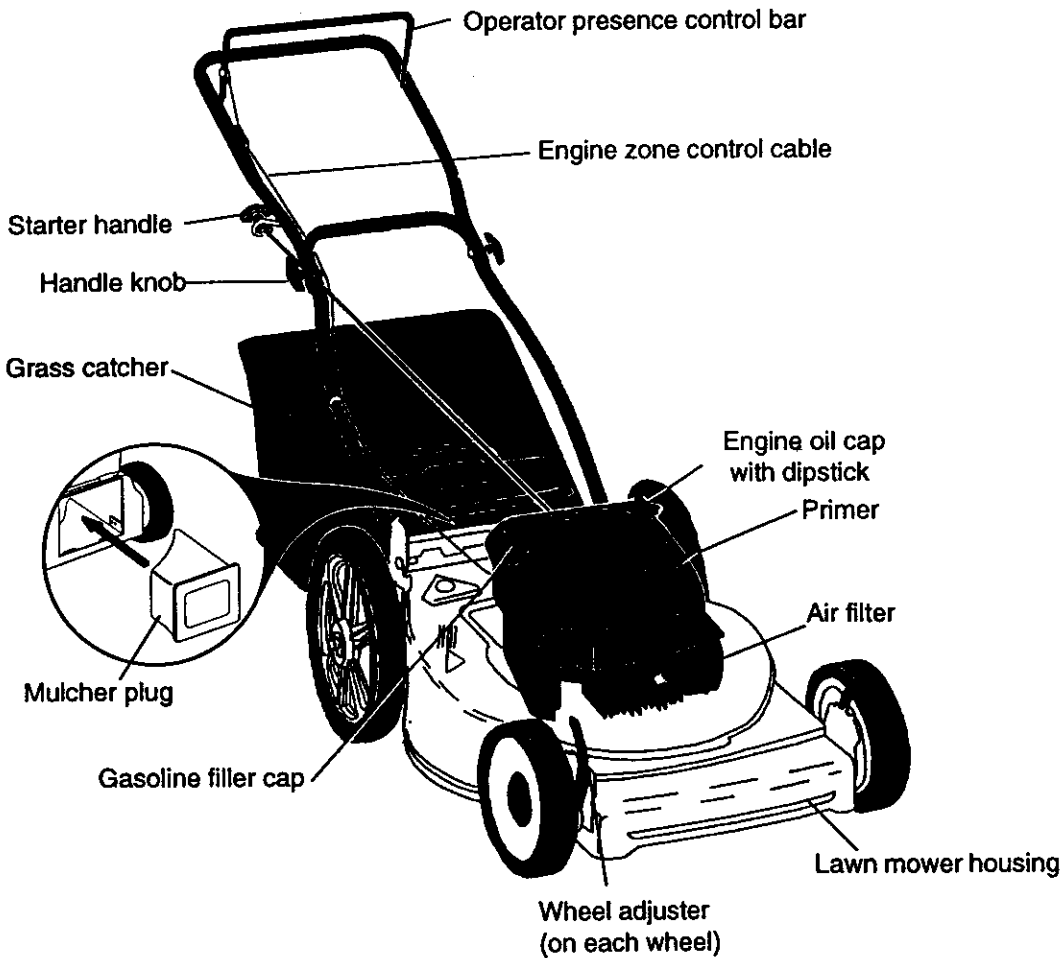

### MEETS CPSC SAFETY REQUIREMENTS

Sears rotary walk-behind power lawn mowers conform to the safety standards of the American National Standards Institute and the U.S. Consumer Product Safety Commission. The blade turns when the engine is running.

**Operator Presence Control Bar**- must be held down to the handle to start the engine. Release to stop the engine.

**Primer** - pumps additional fuel from the carburetor to the cylinder for use when starting a cold engine.

**Starter Handle** - used for starting the engine.

**Mulcher Plug** - located at the discharge opening must be removed when converting to bagging or discharging operation.

The operation of any lawn mower can result in foreign objects thrown into the eyes, which can result in severe eye damage. Always wear safety glasses or eye shields while operating your lawn mower or performing any adjustments or repairs. We recommend a wide vision safety mask over spectacles or standard safety glasses.

## HOW TO USE YOUR LAWN MOWER ENGINE SPEED CONTROL

The engine speed was set at the factory for optimum performance. Speed is not adjustable.

## ENGINE ZONE CONTROL

**▲CAUTION:** Federal regulations require an engine control to be installed on this lawn mower in order to minimize the risk of blade contact injury. Do not under any circumstances attempt to defeat the function of the operator control. The blade turns when the engine is running.

- Your lawn mower is equipped with an operator presence control bar which requires the operator to be positioned behind the lawn mower handle to start and operate the lawn mower.

## TO ADJUST CUTTING HEIGHT

- Raise wheels for low cut and lower wheels for high cut.
- Adjust cutting height to suit your requirements. Medium position is best for most lawns.
- To change cutting height, squeeze adjuster lever toward wheel. Move wheel up or down to suit your requirements. Be sure all wheels are in the same setting.

**NOTE:** Adjuster is properly positioned when plate tab inserts into hole in lever. Also, 9-position adjusters (if so equipped) allow lever to be positioned between the plate tabs.

## Lower Wheels for High Cut

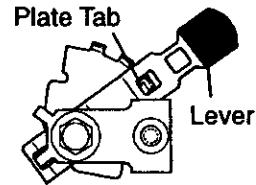
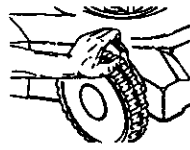

## Raise Wheels for Low Cut TO ATTACH GRASS CATCHER

- Close the flip lid. Flip lid must be closed while operating lawn mower.
- Lift the rear door on the mower housing and place the grass catcher frame onto the formed tabs on the rear door hinge bracket.
- The grass catcher is secured to the lawn mower housing when the rear door is lowered onto the grass catcher frame.

**▲CAUTION:** Do not run your lawn mower without clipping deflector or approved grass catcher in place. Never attempt to operate the lawn mower with the rear door removed or propped open.

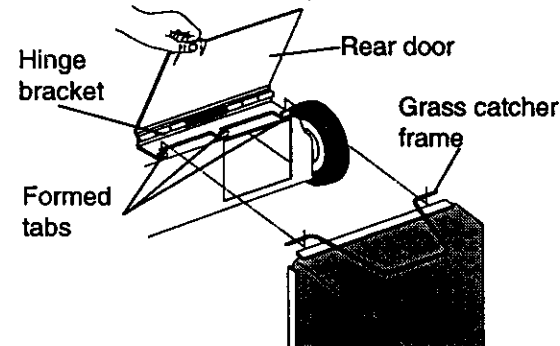

## TO EMPTY GRASS CATCHER

- To remove grass catcher, release operator presence control bar to stop engine.
- Lift up rear door and remove the grass catcher by the handle.

**NOTE:** Do not drag the bag when emptying; it will cause unnecessary wear.

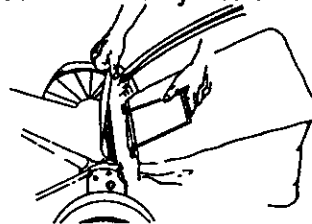

## BEFORE STARTING ENGINE

### OIL

Your lawn mower is shipped without oil in the engine.

- Be sure mower is level and area around oil fill is clean.
- Remove engine oil cap and fill to the full line on the dipstick.
- Use 20 ozs. of oil. For type and grade of oil to use, see "ENGINE" in Maintenance section of this manual.
- Pour oil slowly. Do not over fill.
- Check oil level before each use. Add oil if needed. Fill to full line on dipstick.
- To read proper level, tighten engine oil cap each time.
- Reinstall engine oil cap and tighten.
- Change the oil after every 25 hours of operation or each season. You may need to change the oil more often under dusty, dirty conditions.

### GAS

- Fill fuel tank. Use fresh, clean, regular unleaded gasoline with a minimum of 87 octane. Do not mix oil with gasoline. Purchase fuel in quantities that can be used within 30 days to assure fuel freshness.

**WARNING:** Experience indicates that alcohol blended fuels (called gasohol or using ethanol or methanol) can attract moisture which leads to separation and formation of acids during storage. Acidic gas can damage the fuel system of an engine while in storage. To avoid engine problems, the fuel system should be emptied before storage of 30 days or longer. Drain the fuel tank, start the engine and let it run until fuel lines and carburetor are empty. Use fresh fuel next season. See Storage Instructions for additional information. Never use engine or carburetor cleaner products in fuel tank or permanent damage may occur.

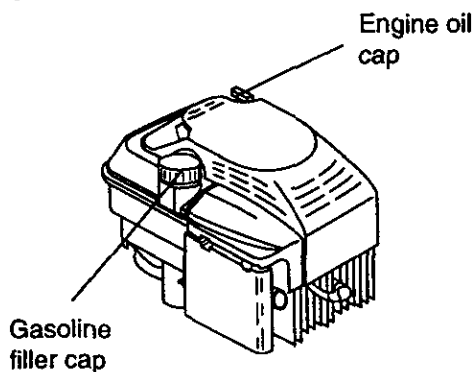

## TO START ENGINE

- To start a cold engine, push primer three (3) times before trying to start. Use a firm push. This step is not usually necessary when starting an engine which has already run for a few minutes.
- Hold operator presence control bar down to the handle and pull starter handle quickly. Do not allow starter rope to snap back.
- To stop engine, release operator presence control bar.

**NOTE:** In cooler weather it may be necessary to repeat priming steps. In warmer weather over priming may cause flooding and engine will not start. If you do flood engine, wait a few minutes before attempting to start and do not repeat priming steps.

## MOWING TIPS

- Under certain conditions, such as very tall grass, it may be necessary to raise the height of cut to reduce pushing effort and to keep from overloading the engine and leaving clumps of grass clippings. It may also be necessary to reduce ground speed and/or run the lawn mower over the area a second time.
- For extremely heavy cutting, reduce the width of cut by overlapping previously cut path and mow slowly.
- For better grass bagging and most cutting conditions, the engine speed should be set in the fast position.
- When using a rear discharge lawn mower in moist, heavy grass, clumps of cut grass may not enter the grass catcher. Reduce ground speed (pushing speed) and/or run the lawn mower over the area a second time.
- If a trail of clippings is left on the right side of a rear discharge mower, mow in a clockwise direction with a small overlap to collect the clippings on the next pass.
- Pores in cloth grass catchers can become filled with dirt and dust with use and catchers will collect less grass. To prevent this, regularly hose catcher off with water and let dry before using.
- Keep top of engine around starter clear and clean of grass clippings and chaff. This will help engine air flow and extend engine life.



## MULCHING MOWING TIPS

**IMPORTANT:** For best performance, keep mower housing free of built-up grass and trash. Clean **UNDERSIDE OF MOWER HOUSING** after each use. See "Cleaning" in **MAINTENANCE** section of this manual.

- The special mulching blade will recut the grass clippings many times and reduce them in size so that as they fall onto the lawn they will disperse into the grass and not be noticed. Also, the mulched grass will biodegrade quickly to provide nutrients for the lawn. Always mulch with your highest engine (blade) speed as this will provide the best recutting action of the blades.
- Avoid cutting your lawn when it is wet. Wet grass tends to form clumps and interferes with the mulching action. The best time to mow your lawn is the early afternoon. At this time the grass has dried and the newly cut area will not be exposed to the direct sun.
- For best results, adjust the lawn mower cutting height so that the lawn mower cuts off only the top one-third of the grass blades. If the lawn is overgrown it will be necessary to raise the height of cut to reduce pushing effort and to keep from overloading the engine and leaving clumps of mulched grass. For extremely heavy mulching, reduce your width of cut, mow slowly and raise the rear of the lawn mower one wheel adjuster setting higher than the front.
- Certain types of grass and grass conditions may require that an area be mulched a second time to completely hide the clippings. When doing a second cut, mow across or perpendicular to the first cut path.
- Change your cutting pattern from week to week. Mow north to south one week then change to east to west the next week. This will help prevent matting and graining of the lawn.



# MAINTENANCE

MAINTENANCE SCHEDULE		SERVICE DATES				
FILL IN DATES AS YOU COMPLETE REGULAR SERVICE		BEFORE EACH USE	AFTER EACH USE	EVERY 10 HOURS	EVERY 25 HOURS OR EVERY SEASON	BEFORE STORAGE
<b>MOWER</b>	Check for Loose Fasteners	✓			✓	
	Clean/Inspect Grass Catcher (If Equipped)	✓	✓		✓	
	Clean Lawn Mower		✓		✓	
	Clean Under Drive Cover (Power-Propelled Mowers)			✓		
	Check drive belt/pulleys (Power-Propelled Mowers)			✓		
	Check/Sharpen/Replace Blade			✓ <sub>3</sub>		
	Lubrication Chart			✓	✓	
<b>ENGINE</b>	Clean Battery/Recharge (Electric Start Mowers)			✓	✓ <sub>4</sub>	
	Check Engine Oil Level	✓				
	Change Engine Oil			✓ <sub>1,2</sub>		
	Clean Air Filter			✓ <sub>2</sub>		
	Inspect Muffler			✓		
	Clean or Replace Spark Plug			✓		
Replace Air Filter Paper Cartridge			✓ <sub>2</sub>			

- 1 - Change more often when operating under a heavy load or in high ambient temperatures.
- 2 - Service more often when operating in dirty or dusty conditions.
- 3 - Replace blades more often when mowing in sandy soil.
- 4 - Charge 48 hours at end of season.

## GENERAL RECOMMENDATIONS

The warranty on this lawn mower does not cover items that have been subjected to operator abuse or negligence. To receive full value from the warranty, operator must maintain mower as instructed in this manual. Some adjustments will need to be made periodically to properly maintain your unit. All adjustments in the Service and Adjustments section of this manual should be checked at least once each season.

- Once a year, replace the spark plug, replace air filter element and check blade for wear. A new spark plug and clean/new air filter element assures proper air-fuel mixture and helps your engine run better and last longer.
- Follow the maintenance schedule in this manual.

## BEFORE EACH USE

- Check engine oil level.
- Check for loose fasteners.

## LUBRICATION

Keep unit well lubricated (See "LUBRICATION CHART").

## LUBRICATION CHART

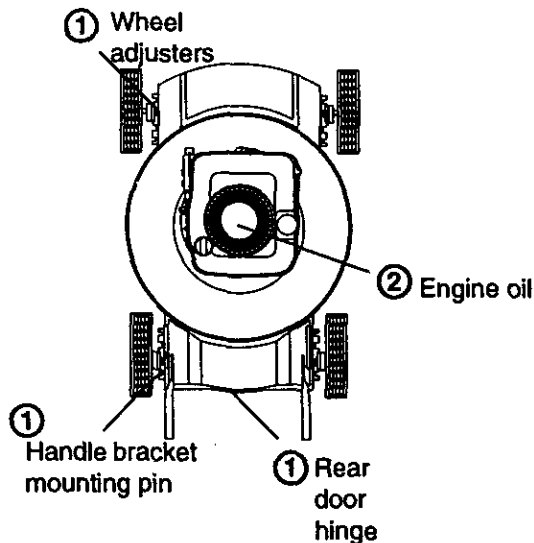

- ① SPRAY LUBRICANT
- ② SAE 30 MOTOR OIL. REFER TO ENGINE - MAINTENANCE SECTION.

**IMPORTANT:** Do not oil or grease plastic wheel bearings. Viscous lubricants will attract dust and dirt that will shorten the life of the self lubricating bearings. If you feel they must be lubricated, use only a dry, powdered graphite type lubricant sparingly.

# PRODUCT SPECIFICATIONS

MODEL NUMBER	917.387402
SERIAL NUMBER	
DATE OF PURCHASE	
HORSEPOWER:	6.0
DISPLACEMENT:	11.5 CU. IN.
GASOLINE CAPACITY/ TYPE:	1.6 QUARTS UNLEADED REGULAR
OIL TYPE (API-SF/SG/SH):	SAE 30 (ABOVE 32°F) SAE 5W-30 (BELOW 32°F)
OIL CAPACITY:	20 OZS.
SPARK PLUG(GAP: .030")	CHAMPION RJ19LM OR J19LM
VALVE CLEARANCE:	INTAKE: .004" - .008" EXHAUST: .004" - .008"
SOLID STATE IGNITION	
AIR GAP:	.0125 IN.
BLADE BOLT TORQUE:	35-40 FT. LBS.
<ul style="list-style-type: none"> <li>• The model and serial numbers will be found on a decal attached to the rear of the lawn mower housing. Record both serial number and date of purchase in space provided above.</li> </ul>	

## LAWN MOWER

Always observe safety rules when performing any maintenance.

## TIRES

- Keep tires free of gasoline, oil, or insect control chemicals which can harm rubber.
- Avoid stumps, stones, deep ruts, sharp objects and other hazards that may cause tire damage.

## BLADE CARE

For best results, mower blade must be kept sharp. Replace bent or damaged blades.

### TO REMOVE BLADE

- Disconnect spark plug wire from spark plug and place wire where it cannot come in contact with spark plug.
- Turn lawn mower on its side. Make sure air filter and carburetor are up.
- Use a wood block between blade and mower housing to prevent blade from turning when removing blade bolt.
- Protect your hands with gloves and/or wrap blade with heavy cloth.
- Remove blade bolt by turning counter-clockwise.

- Remove blade and attaching hardware (bolt, lock washer and hardened washer).

**NOTE:** Remove the blade adapter and check the key inside hub of blade adapter. The key must be in good condition to work properly. Replace adapter if damaged.

### TO REPLACE BLADE

- Position the blade adapter on the engine crankshaft. Be sure key in adapter and crankshaft keyway are aligned.
- Position blade on the blade adapter aligning the two (2) holes in the blade with the raised lugs on the adapter.
- Be sure the trailing edge of blade (opposite sharp edge) is up toward the engine.
- Install the blade bolt with the lock washer and hardened washer into blade adapter and crankshaft.
- Use block of wood between blade and lawn mower housing and tighten the blade bolt, turning clockwise.
- The recommended tightening torque is 35-40 ft. lbs.

**IMPORTANT:** Blade bolt is grade 8 heat treated.

### TO SHARPEN BLADE

**NOTE:** We do not recommend sharpening blade - but if you do, be sure the blade is balanced.

Care should be taken to keep the blade balanced. An unbalanced blade will cause eventual damage to lawn mower or engine.

- The blade can be sharpened with a file or on a grinding wheel. Do not attempt to sharpen while on the mower.
- To check blade balance, drive a nail into a beam or wall. Leave about one inch of the straight nail exposed. Place center hole of blade over the head of the nail. If blade is balanced, it should remain in a horizontal position. If either end of the blade moves downward, sharpen the heavy end until the blade is balanced.

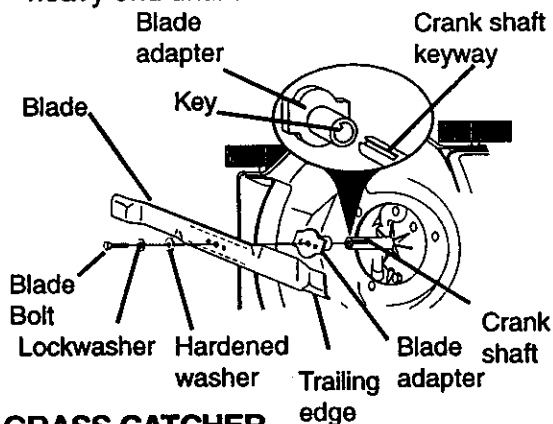

**NOTE:** Although multi—viscosity oils (5W30, 10W30 etc.) improve starting in cold weather, these multi—viscosity oils will result in increased oil consumption when used above 32°F. Check your engine oil level more frequently to avoid possible engine damage from running low on oil.

Change the oil after every 25 hours of operation or at least once a year if the lawn mower is not used for 25 hours in one year.

Check the crankcase oil level before starting the engine and after each five (5) hours of continuous use. Tighten oil plug securely each time you check the oil level.

### TO CHANGE ENGINE OIL

**NOTE:** Before tipping lawn mower to drain oil, drain fuel tank by running engine until fuel tank is empty.

- Disconnect spark plug wire from spark plug and place wire where it cannot come in contact with spark plug.
- Remove engine oil cap; lay aside on a clean surface.
- Tip lawn mower on its side as shown and drain oil into a suitable container. Rock lawn mower back and forth to remove any oil trapped inside of engine.
- Wipe off any spilled oil on lawn mower and on side of engine.
- Fill engine with oil. Fill only to the "FULL" line on the dipstick. **DO NOT OVER FILL.**
- Replace engine oil cap.
- Reconnect spark plug wire to spark plug.

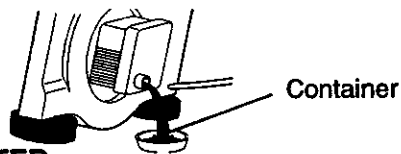

### GRASS CATCHER

- The grass catcher may be hosed with water, but must be dry when used.
- Check your grass catcher often for damage or deterioration. Through normal use it will wear. If catcher needs replacing, replace only with a manufacturer approved replacement catcher. Give the lawn mower model number when ordering.

### ENGINE LUBRICATION

Use only high quality detergent oil rated with API service classification SF, SH or SG. Select the oil's SAE viscosity grade according to your expected operating temperature.

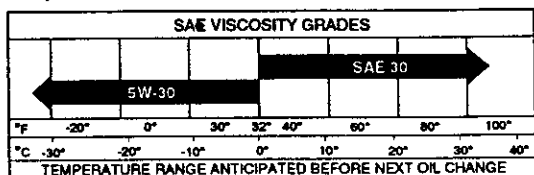

### AIR FILTER

Your engine will not run properly and may be damaged by using a dirty air filter. Replace the air filter every year, more often if you mow in very dusty, dirty conditions.

### TO CLEAN AIR FILTER

- Loosen screw and tilt cover to remove.
  - Carefully remove cartridge.
  - Clean by gently tapping on a flat surface. If very dirty, replace cartridge.
- ▲CAUTION:** Petroleum solvents, such as kerosene, are not to be used to clean cartridge. They may cause deterioration of

the cartridge. Do not oil cartridge. Do not use pressurized air to clean or dry cartridge.

- Install cartridge, then replace cover making sure the tabs are aligned with the slots in the back plate. Fasten screw securely.

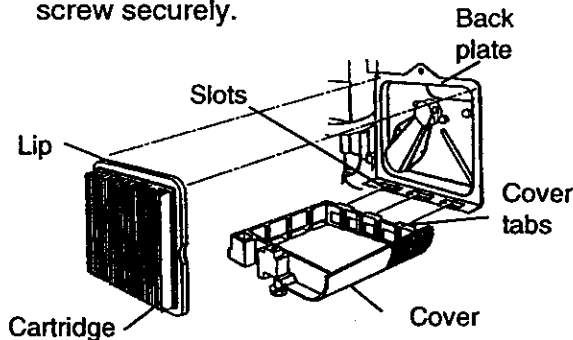

## MUFFLER

Inspect and replace corroded muffler as it could create a fire hazard and/or damage.

## SPARK PLUG

Change your spark plug each year to make your engine start easier and run better. Set spark plug gap at .030 inch.

## CLEANING

**IMPORTANT:** For best performance, keep mower housing free of built-up grass and trash. Clean underside of mower housing after each use.

**▲CAUTION:** Disconnect spark plug wire from spark plug and place wire where it cannot come in contact with the spark plug.

- Clean the underside of your lawn mower by scraping to remove build-up of grass and trash.
- Clean engine often to keep trash from accumulating. A clogged engine runs hotter and shortens engine life.
- Keep finished surfaces and wheels free of all gasoline, oil, etc.
- We do not recommend using a garden hose to clean lawn mower unless the electrical system, muffler, air filter and carburetor are covered to keep water out. Water in engine can result in shortened engine life.

# SERVICE AND ADJUSTMENTS

**▲CAUTION:** Before performing any service or adjustments:

- Release control bar and stop engine.
- Make sure the blade and all moving parts have completely stopped.
- Disconnect spark plug wire from spark plug and place where it cannot come in contact with plug.

## LAWN MOWER

### TO ADJUST CUTTING HEIGHT

See "TO ADJUST CUTTING HEIGHT" in the Operation section of this manual.

### REAR DEFLECTOR

The rear deflector, attached between the rear wheels of your lawn mower, is provided to minimize the possibility that objects will be thrown out the rear of the lawn mower into the operator's mowing position.

If the rear deflector becomes damaged, it should be replaced.

### TO ADJUST HANDLE

Your lawn mower handle can be raised or lowered for your mowing comfort. Four (4) positions are available: high, medium high, medium low and low. Handles are shipped mounted in the medium low position.

- To change from medium low to medium high position, the upper and lower handle sections will have to be turned over.
- Remove the cable clips.
- Remove the controls and operator presence control bar from the upper handle.
- Remove the starter rope guide from the upper handle.
- Remove hairpin cotters.
- Disconnect the lower handle from the handle brackets .
- Turn the handle over and reassemble the hairpin cotters that have been removed.
- Reassemble the starter rope guide.
- Reassemble the controls and the operator presence control bar to the upper handle.

**▲CAUTION:** The operator presence control bar must pivot freely to permit blade brake engagement when control bar is released. Do not over tighten the fasteners holding the controls to the upper handle.

- To change from medium low to high position only the upper handle section will have to be turned over.

- To change from medium low to low position, only the lower handle section will have to be turned over.

Shipping Position

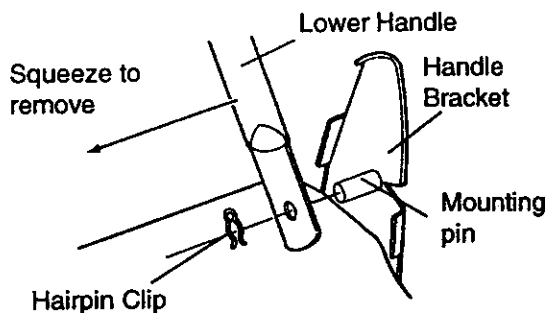
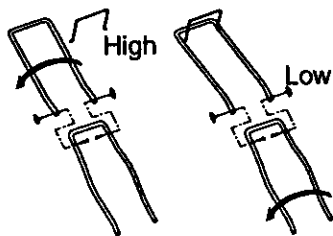
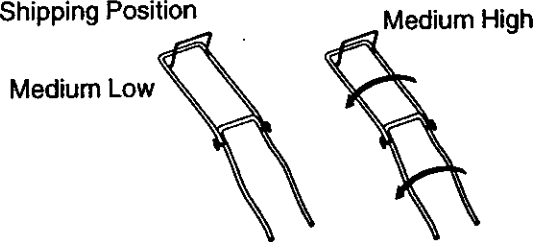

## TO ASSEMBLE GRASS CATCHER

- Insert leg of tubular frame through front opening of grass catcher and thread frame into sewn hem of bag.
- NOTE:** Keep bag hem gathered on the straight leg of the tubular frame.
- When frame comes out the other end of sewn hem, immediately work the end of frame down inside the bag as shown in inset.
- Slide sewn hem evenly around the tubular frame until both ends of frame are exposed out of the front opening.
- Assemble lower frame to tubular frame as shown. Be sure handle is outside of bag and frames are fully seated as shown in inset.
- Slip vinyl bindings over frame.
- NOTE:** If vinyl bindings are too-stiff, hold them in warm water for a few minutes. If bag gets wet, let it dry before using.
- Close the flip lid. Flip lid must be closed while operating lawn mower.

**▲CAUTION:** Do not run your lawn mower without clipping deflector or approved grass catcher in place. Never attempt to operate the lawn mower with the rear door removed or propped open.

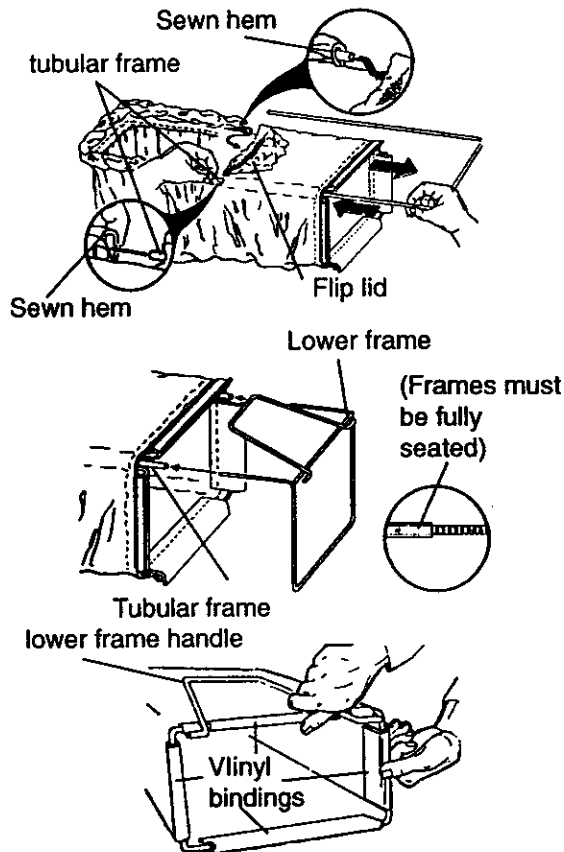

## ENGINE CARBURETOR

Your carburetor has a non-adjustable fixed main jet for mixture control. If your engine does not operate properly due to suspected carburetor problems, take your lawn mower to an authorized service center for repair or adjustment.

**IMPORTANT:** Never tamper with the engine governor, which is factory set for the proper engine speed. Overspeeding the engine above the factory high speed can be dangerous. If you think the engine-governed high speed needs adjusting, contact your nearest authorized service center, which has proper equipment and experience to make any necessary adjustments.

## ENGINE SPEED

Your engine speed has been factory set. Do not attempt to increase engine speed or it may result in personal injury. If you believe that the engine is running too fast or too slow, take your lawn mower to an authorized service center for repair and adjustment.

# STORAGE

Immediately prepare your lawn mower for storage at the end of the season or if the unit will not be used for 30 days or more.

## LAWN MOWER

When lawn mower is to be stored for a period of time, clean it thoroughly, remove all dirt, grease, leaves, etc. Store in a clean, dry area.

- Clean entire lawn mower (See "CLEANING" in the Maintenance section of this manual).
- Lubricate as shown in the Maintenance section of this manual.
- Be sure that all nuts, bolts, screws, and pins are securely fastened. Inspect moving parts for damage, breakage and wear. Replace if necessary.
- Touch up all rusted or chipped paint surfaces; sand lightly before painting.

## HANDLE

You can fold your lawn mower handle for storage.

- Squeeze the bottom ends of the lower handle toward each other until the lower handle clears the handle bracket, then move handle forward.
- Loosen upper handle mounting bolts enough to allow upper handle to be folded back.

**IMPORTANT:** When folding the handle for storage or transportation, be sure to fold the handle as shown or you may damage the control cables.

- When setting up your handle from the storage position, the lower handle will automatically lock into the mowing position.

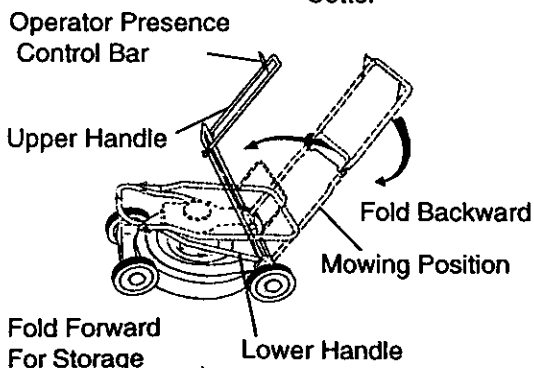
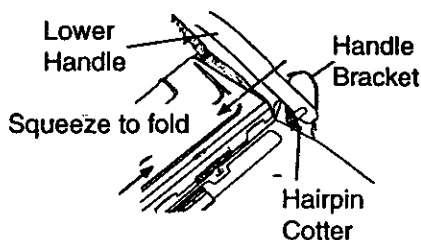

## ENGINE

### FUEL SYSTEM

**IMPORTANT:** It is important to prevent gum deposits from forming in essential fuel system parts such as carburetor, fuel filter, fuel hose, or tank during storage. Also, experience indicates that alcohol blended fuels (called gasohol or using ethanol or methanol) can attract moisture which leads to separation and formation of acids during storage. Acidic gas can damage the fuel system of an engine while in storage.

- Drain the fuel tank.
- Start the engine and let it run until the fuel lines and carburetor are empty.
- Never use engine or carburetor cleaner products in the fuel tank or permanent damage may occur.
- Use fresh fuel next season.

**NOTE:** Fuel stabilizer is an acceptable alternative in minimizing the formation of fuel gum deposits during storage. Add stabilizer to gasoline in fuel tank or storage container. Always follow the mix ratio found on stabilizer container. Run engine at least 10 minutes after adding stabilizer to allow the stabilizer to reach the carburetor. Do not drain the gas tank and carburetor if using fuel stabilizer.

### ENGINE OIL

Drain oil (with engine warm) and replace with clean engine oil. (See "ENGINE" in the Maintenance section of this manual).

### CYLINDER

- Remove spark plug.
- Pour one ounce (29 ml) of oil through spark plug hole into cylinder.
- Pull starter handle slowly a few times to distribute oil.
- Replace with new spark plug.

### OTHER

- Do not store gasoline from one season to another.
- Replace your gasoline can if your can starts to rust. Rust and/or dirt in your gasoline will cause problems.
- If possible, store your unit indoors and cover it to give protection from dust and dirt.

- Cover your unit with a suitable protective cover that does not retain moisture. Do not use plastic. Plastic cannot breathe which allows condensation to form and will cause your unit to rust.

**IMPORTANT:** Never cover mower while engine and exhaust areas are still warm.

**▲ CAUTION:** Never store the lawn mower with gasoline in the tank inside a building where fumes may reach an open flame or spark. Allow the engine to cool before storing in any enclosure.

## TROUBLESHOOTING CHART

PROBLEM	CAUSE	CORRECTION
Does not start	<ul style="list-style-type: none"> <li>• Dirty air filter.</li> <li>• Out of fuel.</li> <li>• Stale fuel.</li> <li>• Water in fuel.</li> <li>• Spark plug wire is disconnected.</li> <li>• Bad spark plug.</li> <li>• Loose blade or broken blade adapter.</li> <li>• Control bar in released position.</li> <li>• Control bar defective.</li> </ul>	<ul style="list-style-type: none"> <li>• Clean/replace air filter.</li> <li>• Fill fuel tank.</li> <li>• Drain tank and refill with fresh clean fuel.</li> <li>• Drain fuel tank and carburetor and refill tank with fresh gasoline.</li> <li>• Connect wire to plug.</li> <li>• Replace spark plug.</li> <li>• Tighten blade bolt or replace blade adapter.</li> <li>• Depress control bar to handle.</li> <li>• Replace control bar.</li> </ul>



## TROUBLESHOOTING CHART

PROBLEM	CAUSE	CORRECTION
Loss of power	<ul style="list-style-type: none"> <li>• Rear of lawn mower housing or cutting blade dragging in heavy grass.</li> <li>• Cutting too much grass.</li> <li>• Dirty air filter.</li> <li>• Buildup of grass, leaves, and trash under mower.</li> <li>• Too much oil in engine.</li> <li>• Walking speed too fast.</li> </ul>	<ul style="list-style-type: none"> <li>• Set to "Higher Cut" position.</li> <li>• Set to "Higher Cut" position.</li> <li>• Clean/replace air filter.</li> <li>• Clean underside of mower housing.</li> <li>• Check oil level.</li> <li>• Cut at slower walking speed.</li> </ul>
Poor cut – uneven	<ul style="list-style-type: none"> <li>• Worn, bent or loose blade.</li> <li>• Wheel heights uneven.</li> <li>• Buildup of grass, leaves and trash under mower.</li> </ul>	<ul style="list-style-type: none"> <li>• Replace blade. Tighten blade bolt.</li> <li>• Set all wheels at same height</li> <li>• Clean underside of mower housing.</li> </ul>
Excessive vibration	<ul style="list-style-type: none"> <li>• Worn, bent or loose blade.</li> <li>• Bent engine crankshaft.</li> </ul>	<ul style="list-style-type: none"> <li>• Replace blade. Tighten blade bolt.</li> <li>• Contact an authorized service center.</li> </ul>
Starter rope hard to pull	<ul style="list-style-type: none"> <li>• Engine flywheel brake is on when control bar is released.</li> <li>• Bent engine crankshaft.</li> <li>• Blade adapter broken.</li> <li>• Blade dragging in grass.</li> </ul>	<ul style="list-style-type: none"> <li>• Depress control bar to upper handle before pulling starter rope.</li> <li>• Contact an authorized service center.</li> <li>• Replace blade adapter.</li> <li>• Move lawn mower to cut grass or to hard surface to start engine.</li> </ul>
Grass catcher not filling (if so equipped)	<ul style="list-style-type: none"> <li>• Cutting height too low.</li> <li>• Lift on blade worn off.</li> <li>• Catcher not venting air.</li> </ul>	<ul style="list-style-type: none"> <li>• Raise cutting height.</li> <li>• Replace blade.</li> <li>• Clean grass catcher.</li> </ul>
Hard to push	<ul style="list-style-type: none"> <li>• Grass is too high or wheel height is too low.</li> <li>• Rear of lawn mower housing or blade dragging in grass.</li> <li>• Grass catcher too full.</li> <li>• Handle height position not right for you.</li> </ul>	<ul style="list-style-type: none"> <li>• Raise cutting height.</li> <li>• Raise rear of lawn mower housing one (1) setting higher.</li> <li>• Empty grass catcher.</li> <li>• Adjust handle height to suit.</li> </ul>



# CRAFTSMAN ROTARY LAWN MOWER -- MODEL NO. 917.387402

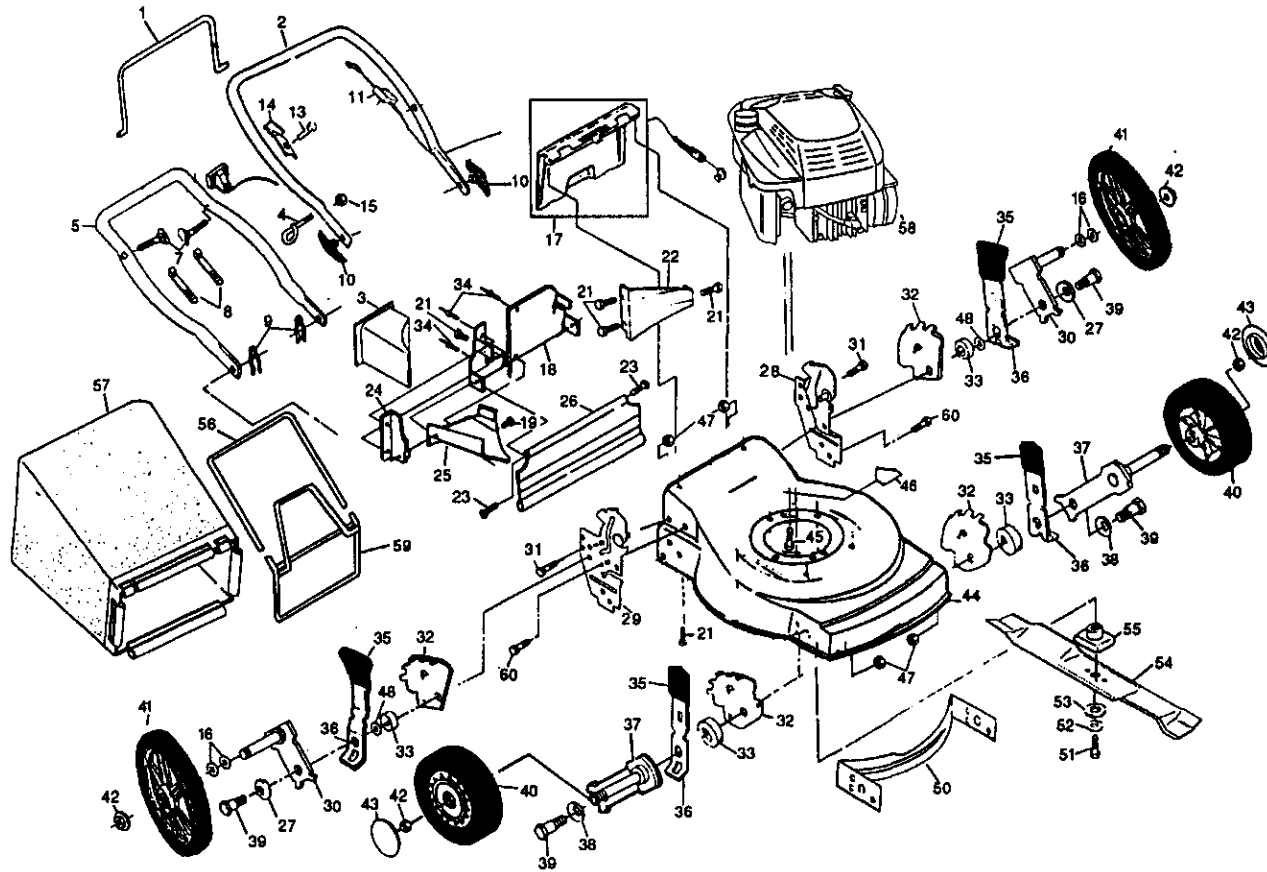

34

REPAIR PARTS

## CRAFTSMAN ROTARY LAWN MOWER - - MODEL NO. 917.387402

KEY NO.	PART NO.	DESCRIPTION	KEY NO.	PART NO.	DESCRIPTION
1	86902	Control Bar	35	87877	Selector Knob
2	165451X479	Upper Handle	36	700331X004	Selector Spring
3	150425	Mulcher Plug	37	145935X004	Axle Arm Assembly
4	132001	Rope Guide	38	62335	Belleville Washer
5	157081X479	Lower Handle	39	142748	Shoulder Bolt
7	131959	Handle Bolt	40	151162	Wheel and Tire Assembly
8	66426	Wire Tie	41	151161	Wheel
9	51793	Hairpin Cotter	42	83923	Hex Flange Locknut
10	136376	Handle Knob	43	77400	Hubcap
11	162778	Engine Zone Control Cable	44	161942	Lawn Mower Housing (Incl. Key #18, 22, 24, 46, 50)
13	750097	Hex Washer Head Screw 10-24 x 1/2	45	150406	Hex Head Thread Rolling Screw 3/8-16 x 1
14	86899X004	Up-Stop Bracket	46	85463	Danger Decal
15	63601	Nut	47	751592	Locknut 3/8-16
16	57143	Wave Washer	48	88348	Flat Washer 3/8
17	151023	Rear Door Assembly Kit	50	165548	Front Baffle
18	156374X479	Back Plate	51	851084	Hex Head Machine Screw 3/8-24 x 1-3/8 (Grd. 8)
19	150050	Self Tapping Screw 10-24 x 5/8	52	850263	Helical Lockwasher 3/8
21	54583	Hex Head Tapping Screw 1/4-20 x 1/2	53	851074	Washer
22	140661X479	Rear Baffle	54	157101	Blade
23	88652	Hinge Screw 1/4-20 x 1-1/4	55	851514	Blade Adapter
24	700365X479	Side Baffle	56	144748	Tube Frame
25	133190X479	Discharge Baffle	57	166070	Grass Bag
26	140540	Rear Deflector	58	-----	Engine - (See Breakdown)
27	61651	Spring Washer			Briggs & Stratton 12H802-2675-E1
28	161814X479	Handle Bracket Assembly (Left)	59	144747	Throat Frame
29	161812X479	Handle Bracket Assembly (Right)	60	74760612	Hex Bolt 3/8-16 x 3/4
30	750913X004	Axle Arm Assembly	--	161058	Warning Decal (Not Shown)
31	150078	Screw 5/16-18 x 3/4	--	167595	Owner's Manual (English/Spanish)
32	700325X007	Wheel Adjusting Bracket			
33	146630	Spacer			
34	128415	Pop Rivet			

Available accessories not included with lawn mower:

<u>Z1</u> 33303	Clipping Deflector
<u>Z1</u> 33623	Gas Can (2.5 gal.)
<u>Z1</u> 33500	Fuel Stabilizer
<u>Z1</u> 33000	SAE 30W Oil (20 oz.)
<u>Z1</u> 33417	Dust Shield
<u>Z1</u> 33316	Mower Cover

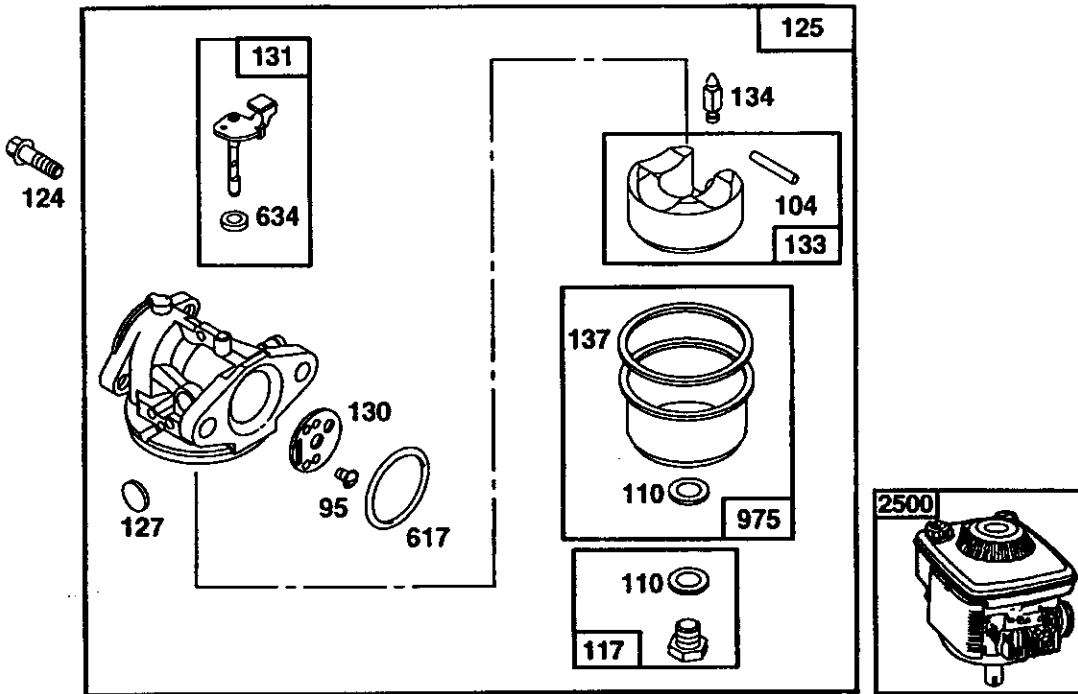
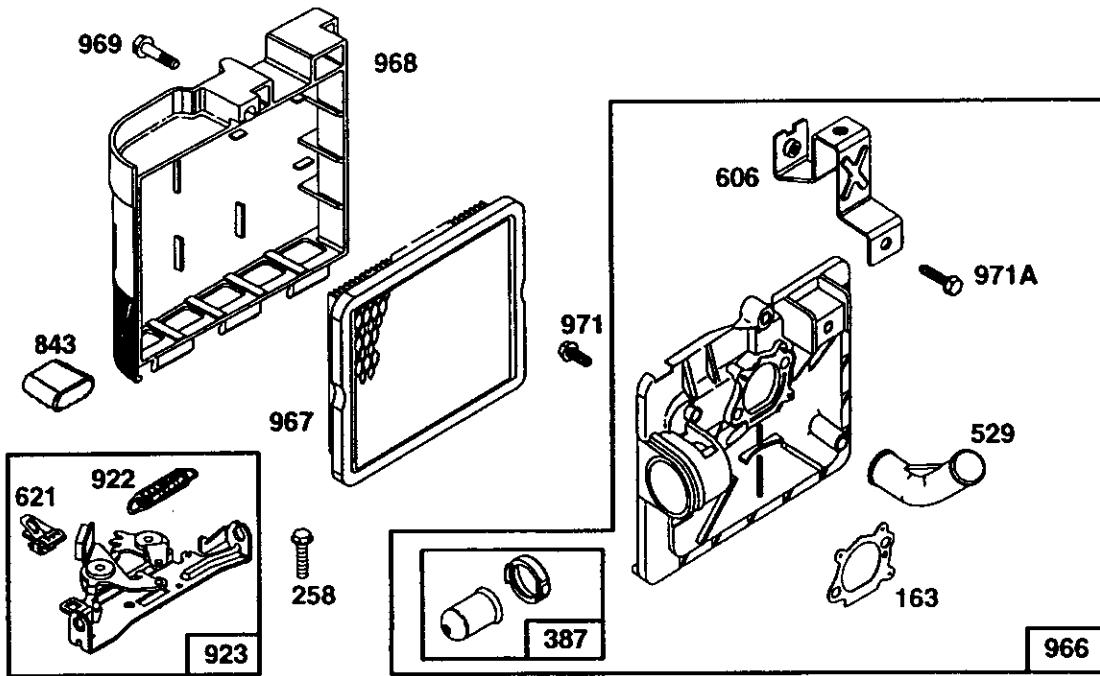

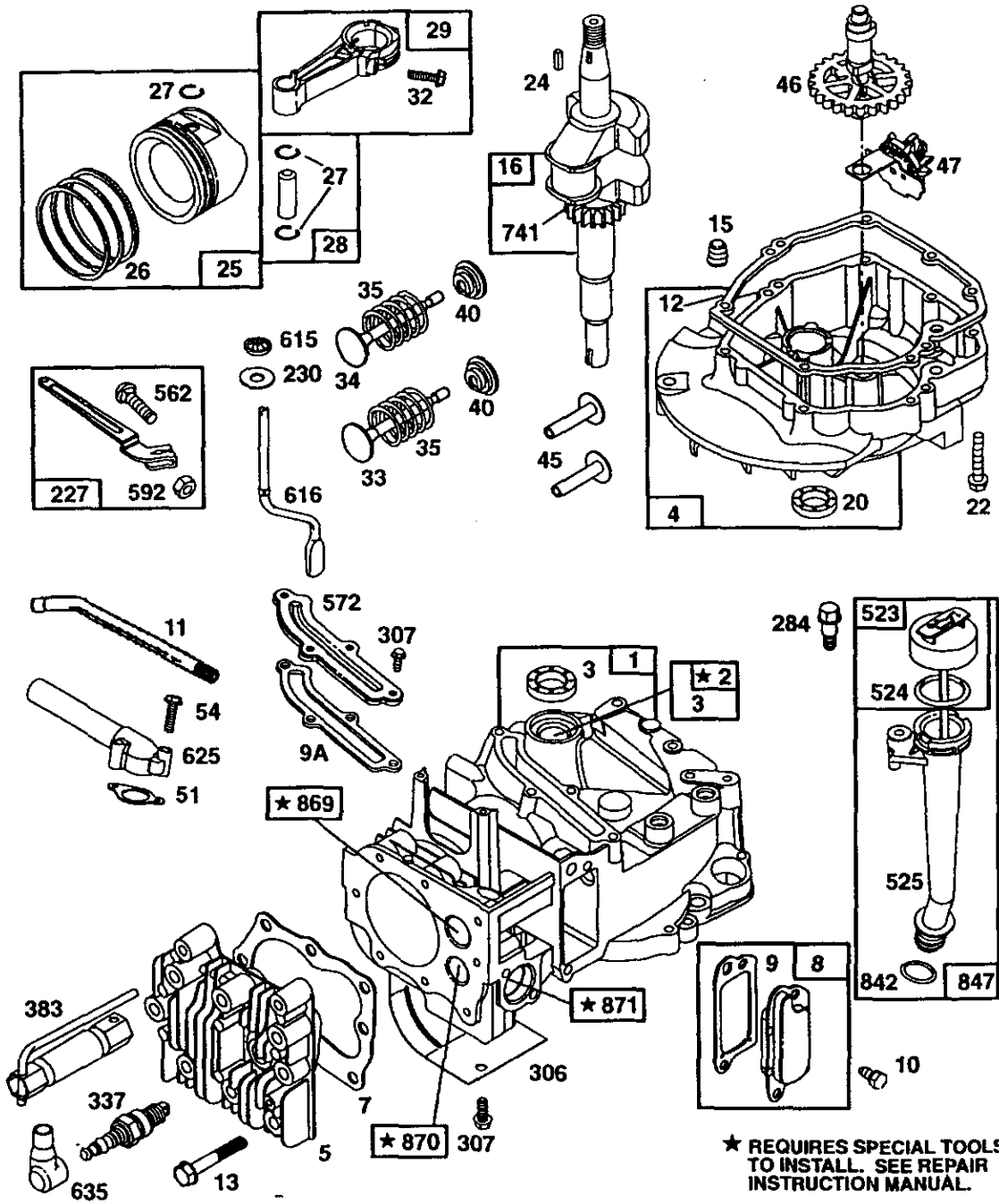

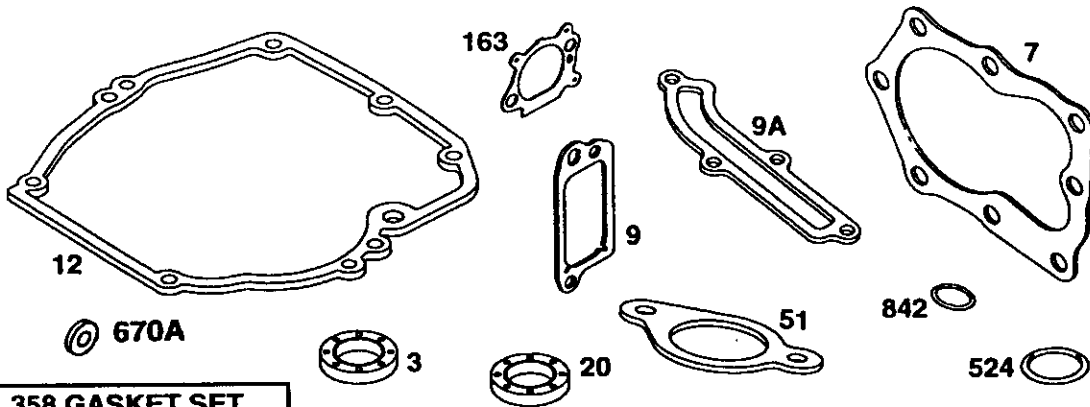

358 GASKET SET

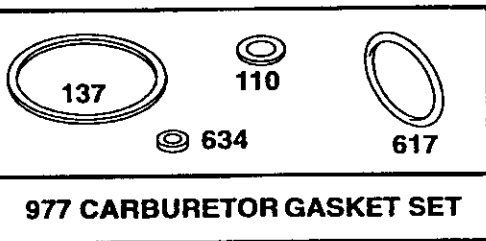

977 CARBURETOR GASKET SET

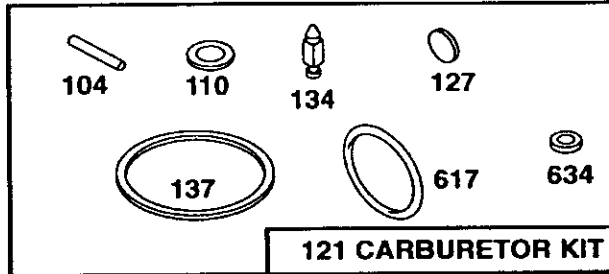

121 CARBURETOR KIT

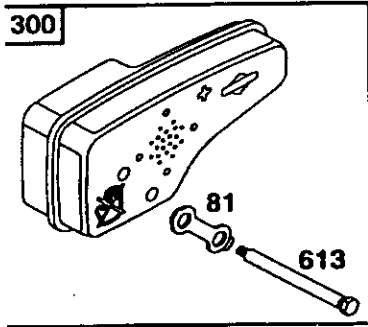

1095 VALVE OVERHAUL GASKET SET

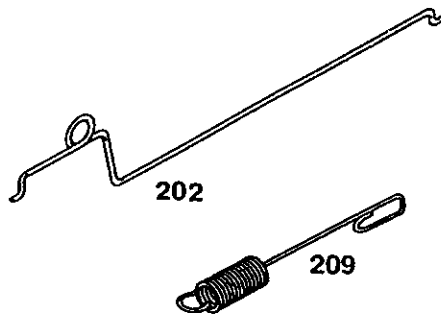
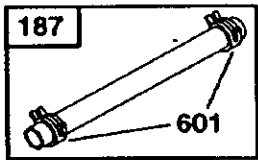
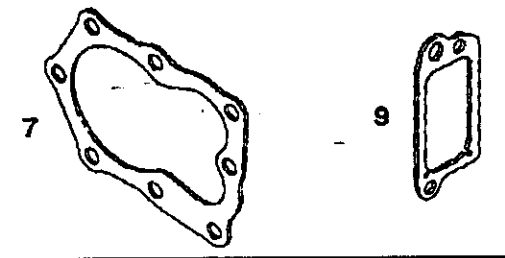
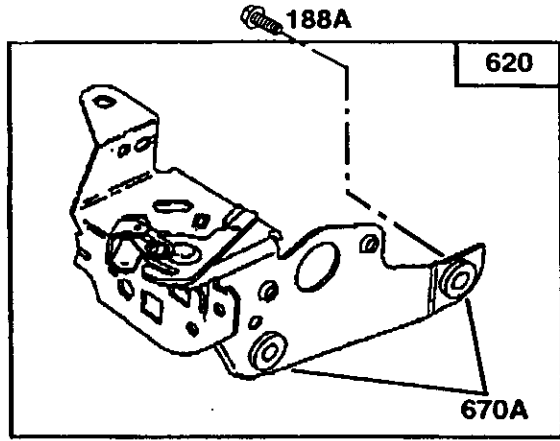

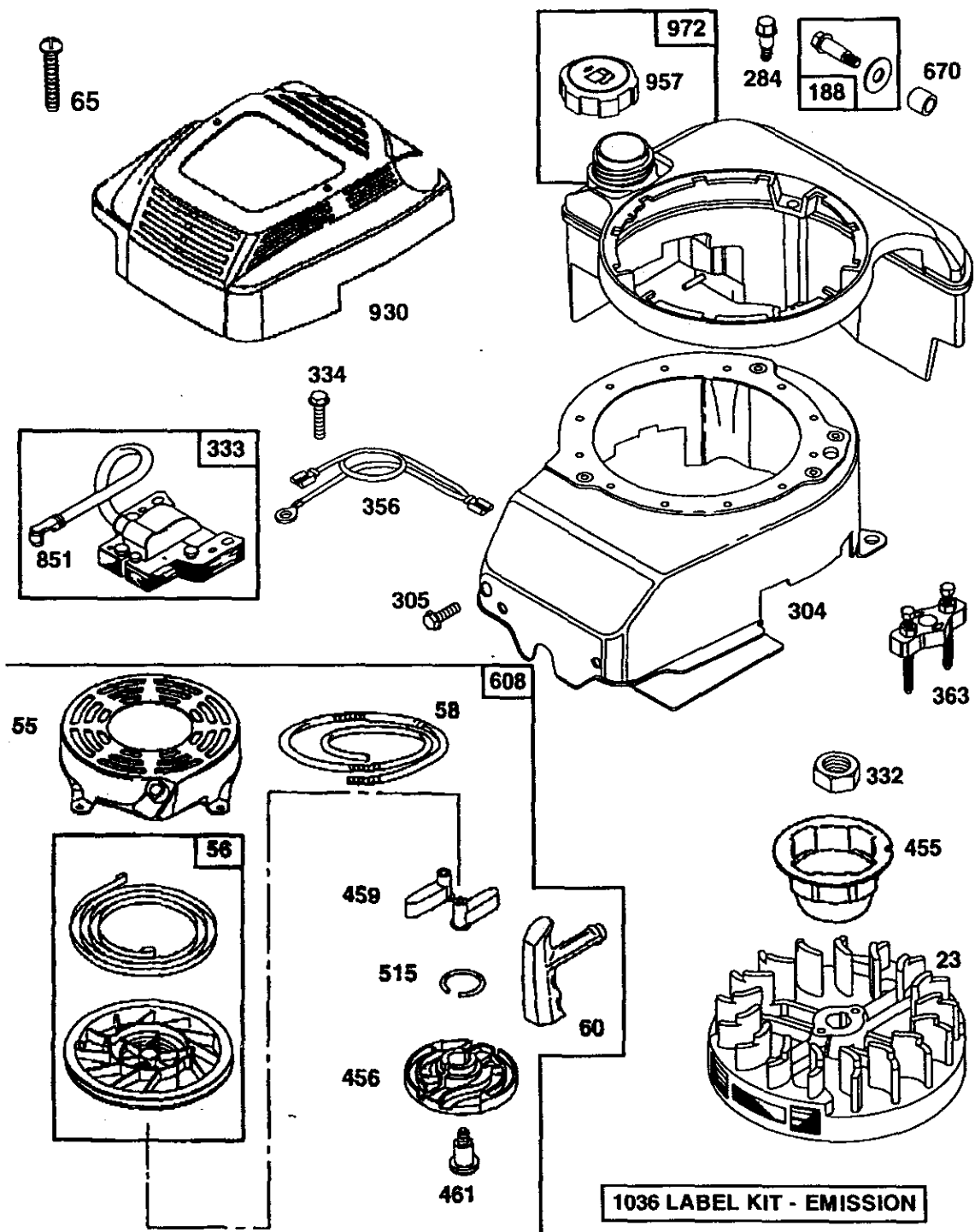



KEY NO.	PART NO.	DESCRIPTION	KEY NO.	PART NO.	DESCRIPTION
1	493260	Cylinder Assembly	54	94526	Screw, Hex Head
2	399269	Bushing, Cylinder	55	4974420	Housing, Rewind Starter
3	299819	* Seat, Oil	56	498144	Pulley, Rewind Starter
4	493279	Sump, Engine	58	280399	Rope, Rewind Starter (Cut To 88-5/8")
5	214368	Head, Cylinder			Grip, Starter Rope
7	272916	**** Gasket, Cylinder Head	60	281434	Screw, Phillips
8	495786	Breather Assembly	65	94696	Lock, Muffler Screw
9	272481	**** Gasket, Valve Cover	81	223664	Screw, Round Head
9A	272238	* Gasket, Baffle Plate	95	94098	** Pin, Float Hinge
10	94650	Screw, Hex Head	104	231371	*** Gasket, Sealing (Sold in Kit Only)
11	231933	Tube, Breather	110	---	Jet, Main
12	272198	* Gasket, Crankcase	117	494870	Carburetor Kit
13	94547	Screw, Cylinder Head	121	498260	Screw, Carburetor Mounting
15	94720	Plug, Oil Drain	124	94525	Carburetor
16	498565	Crankshaft			** Plug, Welch (Sold in Kit Only)
	94388	Timing Gear Key	125	498170	Valve, Throttle
20	399781	* Seal, Oil	127	---	Shaft, Throttle
22	94220	Screw, Hex Head			Float, Carburetor
	94612	Screw, Hex Head (Used in Hole Nearest Breather)	130	224908	Valve, Inlet (Includes Seat)
		Flywheel	131	493267	*** Gasket, Bowl (Sold in Kit Only)
23	492177	Key, Flywheel	133	398187	* Gasket, Air Cleaner
24	222698	Piston Assembly, Standard Size	134	398188	Hose, Fuel
25	499429	Piston Assy. (.010" O.S.)	137	---	Screw, Hex Head
	499430	Piston Assy. (.020" O.S.)	163	272653	Screw, Hex Head
	499431	Piston Assy. (.030" O.S.)	187	492790	Link, Governor
	499432	Ring Set, Piston, Standard Size	188	398540	Spring, Governor
26	499425	Ring Set (.010" O.S.)	188A	94644	
	499426	Ring Set (.020" O.S.)	202	262579	
	499427	Ring Set (.030" O.S.)	209	263044	
27	263190	Lock, Piston Pin	*		Included in Gasket Set (497316)
28	499423	Pin, Piston, Standard Size	**		Included in Carburetor Kit (498260)
29	499424	Rod, Connecting	***		Included in both Carburetor Kit (498260), and Carburetor Gasket Set (498261)
32	94699	Screw, Connecting Rod	****		Included in both Gasket Set (497316), and Valve overhaul Gasket Set (498528).
33	262651	Valve, Exhaust			
34	262652	Valve, Intake			
35	262224	Spring, Valve			
40	93312	Retainer, Valve Spring			
45	262204	Tappet, Valve			
46	498275	Gear, Cam			
47	493737	Slinger, Oil			
51	272199	* Gasket, Intake Elbow			

**NOTE:** All component dimensions given in U.S. inches  
1 inch = 25.4 mm

KEY NO.	PART NO.	DESCRIPTION	KEY NO.	PART NO.	DESCRIPTION
227	492349	Lever, Governor	741	262598	Gear, Timing
230	67072	Washer, Thrust	842	280966	* Seal, O-Ring
258	94512	Screw, Hex Head	843	272616	Sleeve, Lever
284	94511	Screw, Hex Head	847	495263	Tube Assembly, Oil
300	497838	Muffler, Exhaust	851	493880	Terminal, Ignition Cable
304	493293	Housing, Blower	869	213512	Seat, Intake Valve
305	94744	Screw, Sems	870	213513	Seat, Exhaust Valve
306	224324	Shield, Cylinder	871	262001	Guide, Exhaust Valve
307	94515	Screw, Hex Head		63709	Guide, Intake Valve
332	94877	Nut, Flywheel	922	262640	Spring, Brake
333	802574	Armature, Magneto	923	493442	Brake Assembly
334	94731	Screw, Sems	930	497233	Guard, Finger
337	802592	Plug, Spark	957	397974	Cap, Fuel Tank
356	497833	Wire, Ground	966	496116	Base, Air Cleaner
358	497316	Gasket Set	967	491588	Filter, Air
363	19069	Puller, Flywheel	968	281340	Cover, Air Cleaner
383	89838	Wrench, Spark Plug	969	94872	Screw, Hex Head
387	496115	Primer, Carburetor	971	94873	Screw, Hex Head
455	225121	Cup, Starter	971A	94749	Screw, Hex Head
456	281503	Retainer, Starter	972	495224	Tank, Fuel
459	281505	Pawl, Ratchet	975	493640	Bowl, Float
461	94943	Screw, Shoulder	977	498261	Gasket Set, Carburetor
515	263073	Spring, Retainer	1036	499341	Label Kit, Emission
523	495264	Cap, Oil Filler	1095	498258	Gasket Set, Valve
524	280393	* Seal, Filler Tube			Overhaul
525	495265	Tube, Oil Fill	2500	12J802-2915	Replacement Engine
529	281299	Grommet	— —	498826	Replacement Shortblock
562	94852	Bolt, Governor Lever			
572	224328	Baffle, Cylinder			RPM Settings: Low: 1900-2100; High: 3000-3200
592	231082	Nut, Hex			
601	93053	Clamp, Hose			
606	224815	Strap, Bracket			* Included in Gasket Set (497316)
608	497680	Starter, Rewind			** Included in Carburetor Kit (498260)
	Includes:	94904 Screw, Hex			*** Included in both Carburetor Kit (498260), and Carburetor Gasket Set (498261)
		94908 Nut, Hex			**** Included in both Gasket Set (497316), and Valve overhaul Gasket Set (498528).
613	94231	Screw, Hex Head			
615	94474	Fastener			
616	263175	Crank, Governor			
617	270344	*** Seal, Intake Elbow			
620	499135	Bracket, Carburetor			
621	396847	Switch, Stop			
625	497465	Tube, Fuel Intake			
634	---	*** Washer, Shaft (Sold in Kit Only)			<b>NOTE:</b> All component dimensions given in U.S. inches 1 inch = 25.4 mm
635	66538	Elbow, Spark Plug			
670	280512	Spacer, Fuel Tank			
670A	493823	* Spacer, Bracket			





For the repair or replacement parts you need  
delivered directly to your home  
Call 7 am - 7 pm, 7 days a week

**1-800-366-PART**

(1-800-366-7278)

Para ordenar piezas con entrega a  
domicilio - 1-800-659-7084

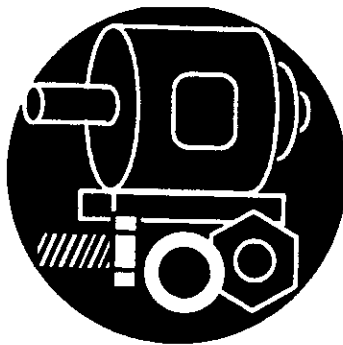

For in-house major brand repair service  
Call 24 hours a day, 7 days a week

**1-800-4-REPAIR**

(1-800-473-7274)

Para pedir servicio de reparación a  
domicilio - 1-800-676-5811



For the location of a Sears Parts and  
Repair Center in your area

Call 24 hours a day, 7 days a week

**1-800-488-1222**



For information on purchasing a Sears  
Maintenance Agreement or to inquire  
about an existing Agreement

Call 9 am - 5 pm, Monday-Saturday

**1-800-827-6655**



When requesting service or ordering  
parts, always provide the following  
information:

- Product Type • Part Number
- Model Number • Part Description

**SEARS**  
**REPAIR SERVICES**

*America's Repair Specialists*

## Free Manuals Download Website

<http://myh66.com>

<http://usermanuals.us>

<http://www.somanuals.com>

<http://www.4manuals.cc>

<http://www.manual-lib.com>

<http://www.404manual.com>

<http://www.luxmanual.com>

<http://aubethermostatmanual.com>

Golf course search by state

<http://golfingnear.com>

Email search by domain

<http://emailbydomain.com>

Auto manuals search

<http://auto.somanuals.com>

TV manuals search

<http://tv.somanuals.com>