

# **SEARS** OWNER'S MANUAL

**MODEL NO.**  
**987.889000**

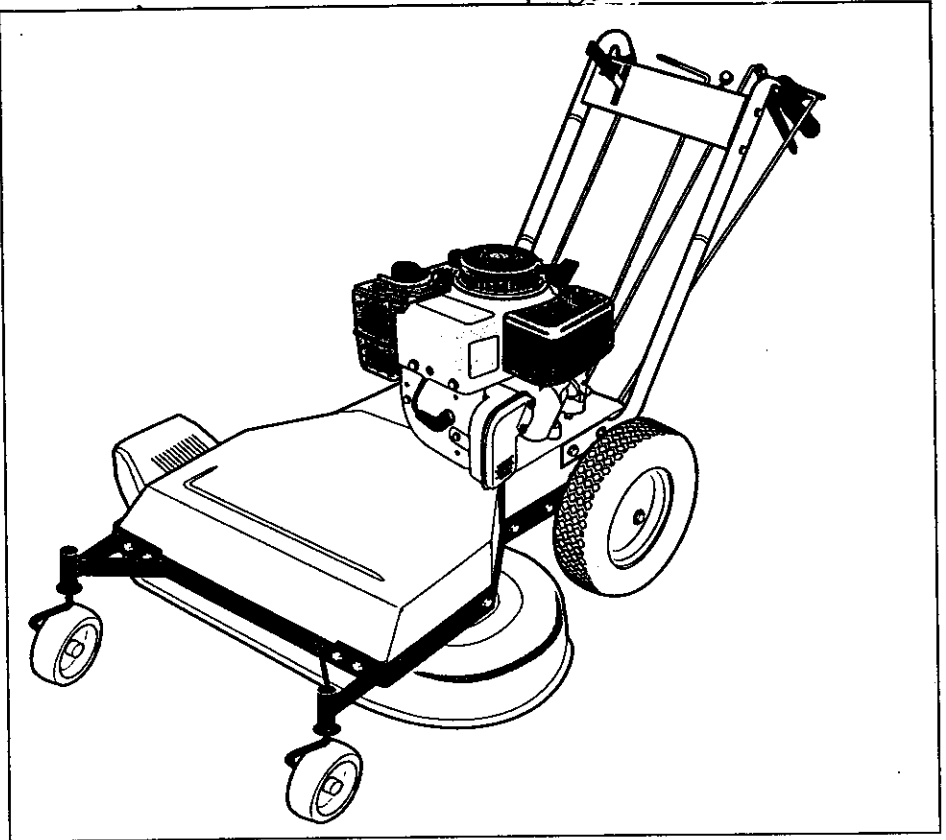

## **CRAFTSMAN<sup>®</sup>** **8 HORSEPOWER** **33-INCH MOWER**



**Caution:**  
Read and Follow  
All Safety Rules  
and Instructions  
Before Operating  
This Equipment.

- **Assembly**
- **Operation**
- **Customer Responsibilities**
- **Service and Adjustments**
- **Repair Parts**

---

**Sears, Roebuck and Co., Hoffman Estates, Illinois 60179 U.S.A.**

---

# SAFETY RULES



**CAUTION: ALWAYS DISCONNECT SPARK PLUG WIRE AND PLACE WIRE WHERE IT CANNOT CONTACT SPARK PLUG TO PREVENT ACCIDENTAL STARTING WHEN SETTING UP, TRANSPORTING, ADJUSTING OR MAKING REPAIRS.**



## IMPORTANT

### Safe Operation Practices for Walk-Behind Mowers

**This cutting machine is capable of amputating hands and feet and throwing objects. Failure to observe the following safety instructions could result in serious injury or death.**



## WARNING:

**The engine exhaust from this product contains chemicals known to the State of California to cause cancer, birth defects, or other reproductive harm.**

## I. GENERAL OPERATION

1. Read, understand, and follow all instructions on the machine and in the manuals. Be thoroughly familiar with the controls and the proper use of the mower before starting.
2. Do not put hands or feet near or under rotating parts. Keep clear of the mower blade and discharge opening at all times.



3. Only allow responsible individuals, who are familiar with the instructions, to operate the mower.
4. Clear the area of objects such as rocks, toys, wire, bones, sticks, etc., which could be picked up and thrown by the blade.
5. Be sure the area is clear of other people before mowing. Stop mower if anyone enters the area. Keep bystanders at least 25 feet away from the area of operation.



6. Do not operate the mower when barefoot or wearing open sandals. Always wear substantial foot wear.
7. Do not pull mower backwards unless absolutely necessary. Look down and behind before and while moving backwards.

8. Do not operate the mower without proper guards, plates, grass catcher or other safety protective devices in place.
9. Refer to provided instructions for proper operation and installation of accessories. Only use accessories approved by Sears, Roebuck and Co.
10. Stop the blade when crossing gravel drives, walks, or roads.
11. Stop the engine and disconnect the spark plug wire from the spark plug whenever you leave the unit, before cleaning the mower or unclogging the chute.

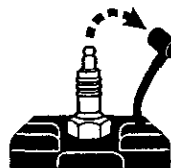

12. Shut the engine off, wait until the blade comes to a complete stop, and disconnect the spark plug wire before installing or removing the mulcher cover or the optional grass catcher. Make certain that the grass catcher is securely attached before operating the mower. Empty the grass catcher after each use—decomposing debris could generate enough heat to catch fire.
13. Mow in daylight or good artificial light.
14. Do not operate the mower while under the influence of alcohol or drugs.
15. Never operate mower in wet grass. Always be sure of your footing; keep a firm hold on the handle and walk; never run.
16. Disengage the Wheel Drive Lever on self-propelled models before starting the engine.
17. If the unit should start to vibrate abnormally, stop the engine and disconnect the spark plug wire. Then check immediately for the cause. Vibration is generally a warning of trouble.



**LOOK FOR THIS SYMBOL TO POINT OUT IMPORTANT SAFETY PRECAUTIONS. IT MEANS— ATTENTION!!! BECOME ALERT!!! YOUR SAFETY IS INVOLVED.**

# SAFETY RULES

18. Always wear safety goggles or safety glasses with side shields when operating mower.
19. Watch for traffic when operating near, or when crossing roadways.
20. Never attempt to carry children or other passengers on the mower. They could fall off and be seriously injured, or they could interfere with the safe operation of the mower.
21. Check the operation of the Operator Presence Control before each use. See the Customer Responsibilities Section of this manual for instructions. If the mower blades rotate longer than three seconds after the Operator Presence Control is released, the system is not working properly. Immediately contact your local Sears Service Center/Department for instructions. Do not use the mower until the mechanism is repaired.
22. The mower is equipped with a safety discharge chute, comes with a special mulcher cover and offers an optional grass catcher. The safety discharge chute must be working properly at all times. Never attempt to disconnect or otherwise cause this discharge chute to cease working. If used, mulcher cover or grass catcher attachment must be installed properly and function correctly. Do not use your equipment otherwise.
23. Never run the engine in an enclosed area. Engine exhaust contains carbon monoxide, a deadly gas that is odorless, colorless, and tasteless. Always run the engine outdoors and make sure there is adequate ventilation.

## II. SLOPE OPERATION

Slopes are a major factor related to slip and fall accidents which can result in severe injury. All slopes require extra caution. If you feel uneasy on a slope, do not mow it.



### DO:

- Mow across the face of slopes; never up and down. Exercise extreme caution when changing direction on slopes. Avoid slopes greater than 15°.
- Remove objects such as rocks, tree limbs, etc.
- Watch for holes, ruts, or bumps. Tall grass can hide obstacles.

### DO NOT:

- Do not* mow near drop-offs, ditches, or embankments. The operator could lose footing or balance.
- Do not* mow excessively steep slopes.
- Do not* mow on wet grass. Reduced footing could cause slipping.

## III. CHILDREN

Tragic accidents can occur if the operator is not alert to the presence of children. Children are often attracted to the mower and to the mowing activity. **Never assume that children will remain where you last saw them.**

1. Keep children out of the mowing area and under the watchful care of a responsible adult.
2. Be alert and turn mower off if children enter the area.
3. Before and while moving backwards, look behind and *down* for small children.
4. Never allow children to operate the mower.
5. Use extra care when approaching blind corners, shrubs, trees, or other objects that may obscure vision.

## IV. SERVICE

1. Use extra care in handling gasoline and other fuels. They are flammable and their vapors are explosive.
  - a) Use only an approved container.
  - b) Never remove gas cap or add fuel when the engine is running. Allow engine to cool before refueling. Do not smoke.
  - c) Never refuel the machine indoors.
  - d) Never store the machine or fuel container inside where there is an open flame, such as a water heater, etc.
  - e) Move mower away from any gasoline fumes before starting the engine.
2. Never run an engine inside a closed area.
3. Never make adjustments or repairs with the engine running. Disconnect the spark plug wire and keep the wire away from the plug to prevent accidental starting.
4. Keep all nuts and bolts, especially the blade attachment bolts, tight and keep equipment in good condition.
5. Never tamper with safety devices. Check their operation regularly.

---

# SAFETY RULES

---

6. Keep mower free of grass, leaves or other debris build-up. Clean up oil or fuel spillage. Allow mower to cool before storing.
7. After striking an object, stop the engine and disconnect the spark plug wire. Inspect the mower and repair, if necessary, before restarting.
8. Never attempt to make mower cutting height adjustments while the engine is running.
9. Grass catcher components are subject to wear, damage and deterioration, which could expose moving parts or allow objects to be thrown. Frequently check components and replace with Sears recommended parts, when necessary.
10. Mower blades are sharp and can cut. Wrap the blade or wear gloves, and use extra caution when servicing them.
11. Do not change the engine governor setting or overspeed the engine.
12. Do not touch engine parts which may be hot from operation. Allow parts to cool completely before inspecting, cleaning or repairing the mower.
13. To access the underside of the mower, tip the mower rearward. Do not tip the mower forward or on either of its sides, unless specifically advised to do so in this manual.
14. Maintain or replace safety and instructional decals. Refer to the Repair Parts Section for replacement decal information.



**CONGRATULATIONS** on your purchase of a Craftsman 33-Inch Mower. It has been designed, engineered and manufactured to give you the best possible dependability and performance.

Should you experience any problems you cannot easily remedy, please contact your nearest Sears Service Center/Department. We have competent, well-trained technicians and the proper tools to service or repair this machine.

Please read and retain this manual. The instructions will help you assemble and maintain your machine properly. Always observe the "SAFETY RULES."

MODEL NUMBER: 987.889000

SERIAL  
NUMBER: \_\_\_\_\_

DATE OF  
PURCHASE: \_\_\_\_\_

THE MODEL AND SERIAL NUMBERS WILL BE FOUND ON A DECAL LOCATED RIGHT SIDE OF THE MOWER DECK.

YOU SHOULD RECORD BOTH THE SERIAL NUMBER AND DATE OF PURCHASE AND KEEP IN A SAFE PLACE FOR FUTURE REFERENCE.

### MAINTENANCE AGREEMENT

A Sears maintenance agreement is available on this product. Contact your nearest Sears store for details.

### PRODUCT SPECIFICATIONS

HORSEPOWER:	8 HP
DISPLACEMENT:	19.43 CU. IN.
FUEL CAPACITY:	3 Quarts
SPARK PLUG (GAP .030-in.):	Champion RJ-17LM or equivalent
IGNITION	Electronic
NET ENGINE WEIGHT	57 LBS.

\* In Canada, replace spark plug with a resistor plug.

**WARNING:** This machine is equipped with an internal combustion engine and should not be used on or near any unimproved forest-covered, brush-covered or grass-covered land unless the engine's exhaust system is equipped with a spark arrester meeting applicable local or state laws (if any). If a spark arrester is used, it should be maintained in effective working order by the operator.

In the state of California the above is required by law (Section 4442 of the California Public Resources Code). Other states may have similar laws. Federal laws apply on federal lands. This engine is not equipped with a spark arrester for the muffler. A spark arrester for the muffler is available through your nearest Sears authorized service center. See the REPAIR PARTS section of this manual.

### CUSTOMER RESPONSIBILITIES

- Read and observe the safety rules.
- Follow a regular schedule in maintaining, caring for and using this product.
- Follow the instructions under "CUSTOMER RESPONSIBILITIES" and "STORAGE" sections of this manual.

## LIMITED TWO-YEAR WARRANTY ON CRAFTSMAN® POWER MOWER

For two years from date of purchase, when this Craftsman® Lawn Mower is maintained, lubricated, and tuned up according to the operating and maintenance instructions in the owner's manual, Sears will repair free of charge any defect in material or workmanship.

If this Craftsman® Lawn Mower is used for commercial or rental purposes, this warranty applies for only 90 days from the date of purchase.

#### THIS WARRANTY DOES NOT COVER:

- Expendable items which become worn during normal use, such as rotary mower blades, blade adapters, belts, air cleaners and spark plug.
- Repairs necessary because of operator abuse or negligence, including bent crankshafts and the failure to maintain the equipment according to the instructions contained in the owner's manual.

**WARRANTY SERVICE IS AVAILABLE BY RETURNING THE CRAFTSMAN® MOWER TO THE NEAREST SEARS SERVICE CENTER/ DEPARTMENT IN THE UNITED STATES. THIS WARRANTY APPLIES ONLY WHILE THIS PRODUCT IS IN USE IN THE UNITED STATES.**

This warranty gives you specific legal rights, and you may also have other rights which vary from state to state.

One year warranty on the following: #38700, #38607, #38712, #38720, #38721, #38725

# TABLE OF CONTENTS

SAFETY RULES.....2	SERVICE AND ADJUSTMENTS.....26
CUSTOMER RESPONSIBILITIES .....5, 23	STORAGE.....34
PRODUCT SPECIFICATIONS.....5	TROUBLESHOOTING.....35
WARRANTY.....5	DECALS.....36
ACCESSORIES AND ATTACHMENTS.....7	REPAIR PARTS - MOWER.....37
ASSEMBLY.....8	REPAIR PARTS - ENGINE.....46
OPERATION .....13	PARTS ORDERING/SERVICE .....Back Cover
CUSTOMER RESPONSIBILITIES .....5, 23	

## INDEX

<p style="text-align: center;"><b>A</b></p> <p>Accessories and Attachments . . . .7</p> <p>Adjustments:</p> <p style="padding-left: 20px;">Height of Cut . . . . .15</p> <p>Air Cleaner . . . . .25</p> <p>Assembly . . . . .8</p> <p style="text-align: center;"><b>B</b></p> <p>Blade:</p> <p style="padding-left: 20px;">Replacement . . . . .32</p> <p style="padding-left: 20px;">Sharpening . . . . .32</p> <p>Blade Drive Control . . . . .14</p> <p style="text-align: center;"><b>C</b></p> <p>Carburetor . . . . .26</p> <p>Controls:</p> <p style="padding-left: 20px;">Blade Drive Control . . . . .14</p> <p style="padding-left: 20px;">Cutting Height Lever . . . . .15</p> <p style="padding-left: 20px;">Engine Throttle Control . . . . .16</p> <p style="padding-left: 20px;">Gear Select Lever . . . . .14</p> <p style="padding-left: 20px;">Operator Presence Control . . . . .13</p> <p style="padding-left: 20px;">Wheel Drive Control . . . . .15</p> <p>Customer Responsibilities:</p> <p style="padding-left: 20px;">Air Filter . . . . .25</p> <p style="padding-left: 20px;">Blade Care/Replacement . . . . .32</p> <p style="padding-left: 20px;">Engine . . . . .24-25</p> <p style="padding-left: 20px;">Lubrication . . . . .23</p> <p style="padding-left: 20px;">Spark Plug . . . . .26</p> <p style="text-align: center;"><b>D</b></p> <p>Decals . . . . .36</p> <p style="text-align: center;"><b>E</b></p> <p>Engine:</p> <p style="padding-left: 20px;">Air Filter . . . . .25</p> <p style="padding-left: 20px;">Cleaning . . . . .24</p> <p style="padding-left: 20px;">Oil . . . . .24</p> <p style="padding-left: 20px;">Operation . . . . .13</p> <p style="padding-left: 20px;">Recoil Start Rope . . . . .16</p> <p style="padding-left: 20px;">Spark Plug . . . . .26</p> <p style="padding-left: 20px;">Storage . . . . .34</p>	<p style="text-align: center;"><b>F</b></p> <p>Features/Controls . . . . .13</p> <p>Fuel Storage . . . . .17, 34</p> <p>Fuel Type . . . . .17</p> <p style="text-align: center;"><b>G</b></p> <p>Gear Select Lever . . . . .14</p> <p style="text-align: center;"><b>H</b></p> <p>Handlebar:</p> <p style="padding-left: 20px;">Assembly . . . . .9</p> <p style="text-align: center;"><b>L</b></p> <p>Lubrication:</p> <p style="padding-left: 20px;">Engine . . . . .17, 23</p> <p style="padding-left: 20px;">Mower . . . . .23</p> <p style="text-align: center;"><b>M</b></p> <p>Maintenance:</p> <p style="padding-left: 20px;">Agreement . . . . .5</p> <p style="padding-left: 20px;">Schedule . . . . .23</p> <p>Mowing Tips . . . . .21</p> <p>Mulching Cover . . . . .15, 18</p> <p style="text-align: center;"><b>O</b></p> <p>Off-Season Storage . . . . .34</p> <p>Oil . . . . .17, 23</p> <p>Operation . . . . .13</p> <p>Operator Presence Control . . . . .13</p> <p>Options . . . . .7</p> <p style="text-align: center;"><b>P</b></p> <p>Parts List . . . . .21-27</p> <p>Product Specifications . . . . .4</p>	<p style="text-align: center;"><b>R</b></p> <p>Recoil Start Rope . . . . .16</p> <p>Repair Parts . . . . .37</p> <p>Responsibilities, Customer . . .5, 23</p> <p style="text-align: center;"><b>S</b></p> <p>Safety Decals . . . . .36</p> <p>Safety Rules . . . . .2</p> <p>Service and Adjustments . . . . .26</p> <p>Spark Plug . . . . .26</p> <p>Specifications . . . . .5</p> <p>Starting/Stopping Engine . . . . .19</p> <p>Storage . . . . .34</p> <p style="text-align: center;"><b>T</b></p> <p>Troubleshooting . . . . .35</p> <p style="text-align: center;"><b>U</b></p> <p>Unpacking . . . . .8</p> <p style="text-align: center;"><b>W</b></p> <p>Warranty . . . . .5</p> <p>Wheel Drive Control . . . . .15</p>
---	--	---

**OPERATOR'S POSITION**

All references in this Manual to LEFT and RIGHT sides of the mower are given from the operator's position behind the handlebars (unless specified otherwise).

# ACCESSORIES AND ATTACHMENTS

These accessories and attachments were available when the mower was purchased. They are also available at most Sears retail outlets, catalog and service centers. Most Sears stores can order repair parts for you when you provide the model number of your unit.

## ENGINE

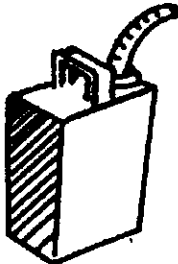
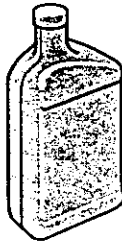
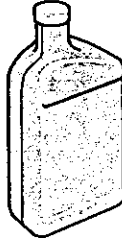
<p>Spark Plug</p>  A detailed line drawing of a spark plug, showing the ceramic insulator, the central electrode, and the hexagonal base.	<p>Gas Can</p>  A line drawing of a rectangular gas can with a handle on top and a spout on the right side.	<p>Fuel Stabilizer</p>  A line drawing of a rectangular fuel stabilizer bottle with a narrow neck and a cap.	<p>Motor Oil</p>  A line drawing of a rectangular motor oil bottle with a narrow neck and a cap.
--	--	---	---

## MOWER

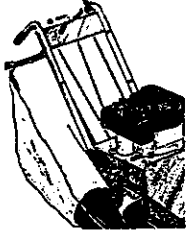
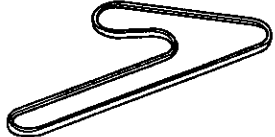
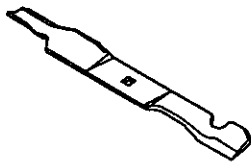
<p>Grass Catcher</p>  A line drawing of a grass catcher attachment, showing a metal frame and a collection bag.	<p>Belt</p>  A line drawing of a curved metal belt component.	<p>Blade</p>  A line drawing of a long, thin metal blade with a mounting hole and a cutting edge.
--	--	---

# CONTENTS OF HARDWARE PACK

## Parts Bag Contents

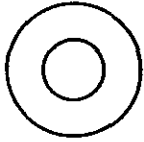

**Flat Washer,  
5/16"  
Qty: 4**

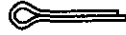

**Cotter Pin,  
3/32" x 5/8"  
Qty: 6**

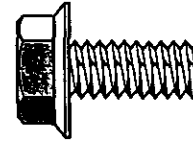

**Hex Flange Lock Screw,  
5/16" - 18 x 3/4"  
Qty: 2**

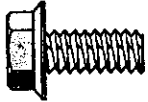

**Hex Flange Lock Screw,  
1/4" - 20 x 1/2"  
Qty: 2**



**Hex Flange Lock Nut,  
1/4" - 20"  
Qty: 2**

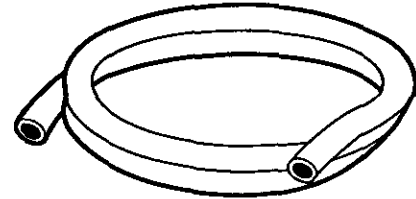

**Oil Drain Tube (shown reduced size)  
Qty: 1**

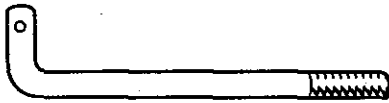

**Shift Link - Gear Select Lever  
(shown reduced size)  
Qty: 1**



**Plastic Cable Tie  
(shown reduced size)  
Qty: 1**

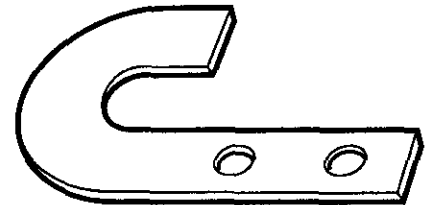

**Shift Rod Mounting Plate  
(shown reduced size)  
Qty: 1**



# ASSEMBLY

Read these instructions in their entirety before you attempt to assemble or operate your new equipment. Your new equipment has been assembled at the factory with the ex-

ception of those parts left unassembled for shipping purposes. To ensure safe and proper operation of your machine, all parts and hardware you install or adjust must be

tightened according to the assembly instructions. Use the correct tools as necessary to ensure proper tightness.

## Tools Needed For Assembly:

- (1) 7/16" Wrench
- (1) 3/8" Wrench
- (2) 1/2" Wrenches
- (1) Needle-nose Pliers
- (1) Wire Cutter Pliers
- (1) Tire Gauge
- (1) Scissors or Pen Knife

## UNPACKING INSTRUCTIONS

- Inspect your machine immediately. Be sure neither the carton nor contents have been damaged. If you find or have reason to suspect damage, contact your nearest Sears Service Center/Department for assistance.
- Cut plastic banding with scissors. Open box flaps and remove any packing material from around the machine. Remove any staples securing bottom of carton to wood pallet. Lift off carton. Cut metal straps securing unit to base. Leave unit on base of pallet during assembly steps (to safely remove unit from base, wait until you have completed assembly steps 1-2). Before disposing of the carton or any of the packing materials, be sure to check them thoroughly for any small parts.
- Cut plastic tie straps holding three long control rods to handlebars. Also remove any packaging around the handlebars.
- Perform the assembly on a clean, level surface. If you need to move the machine, be careful not to severely bend any of the control cables on the equipment.

## ASSEMBLY STEPS

**Before starting any assembly steps, disconnect the engine spark plug wire from the spark plug.**

### STEP 1: Attach Handlebars

- If applicable, cut and remove any plastic ties holding wheel drive rod (F, Figure 2-5) to left handlebar and blade drive rod (C, Figure 2-5) to right handlebar. Put rods aside.
- Handlebars (A, Figure 2-2) are shipped partially assembled with two screws (Y, Figure 2-2) loosely installed. It may be necessary to loosen screws (Y) further to allow the handlebars to clear the engine air cleaner.
- Rotate handlebars over engine and position as shown in Figure 2-2. Be careful that the handlebars clear the unit while unfolding. Also, put end of control rod (E, Figures 2-3 and 2-5) into cut-out (W, Figures 2-2 and 2-3) in back of frame while rotating handlebars into position.
- Install two 5/16"-18 x 3/4" hex flange screws (B, Figure 2-2).
- Tighten all four screws (B and Y).
- Secure the engine throttle cable to the left handlebar with a cable tie from the hardware bag. Clip off any excess tie length.

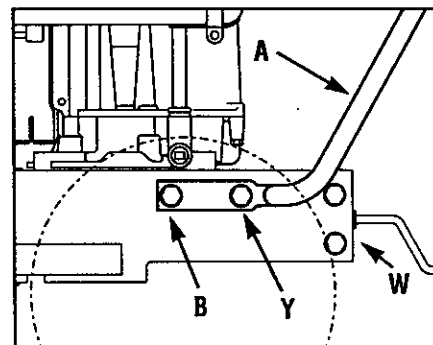

Figure 2-2: Attach handlebars.

# ASSEMBLY

## STEP 2: Attach Control Rods

### ! WARNING

The control rods are adjusted at the factory and should not require additional adjustment during assembly. After assembling unit, control rod adjustment should be checked (and re-adjusted, if necessary) according to information in "Customer Responsibilities" Section. Severe personal injury or property damage could result from not following this instruction.

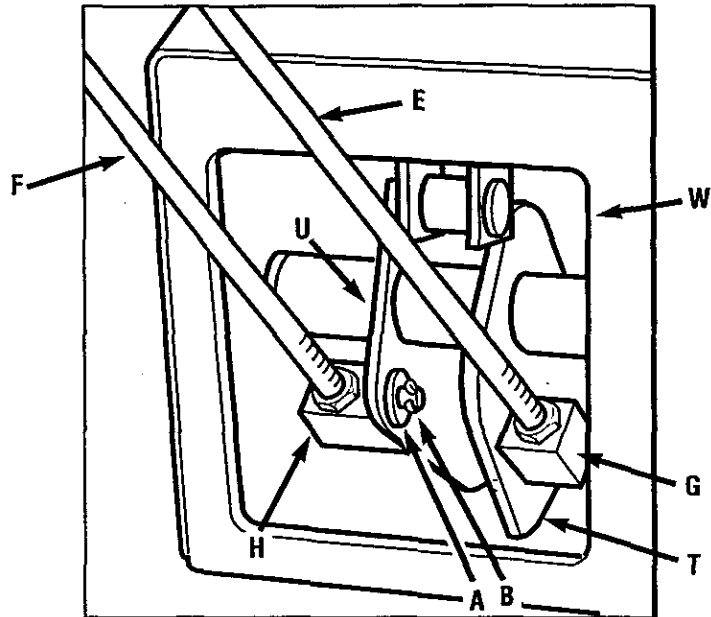

Figure 2-3: Left-hand control rods detail.

### A. Attach Wheel Drive Control Rod

- Locate the wheel drive control rod (F, Figures 2-3 & 2-5) that you removed from the left handlebar in Step 1. This rod has a swivel block (H, Figure 2-3) on one end.
- At left side of engine frame, insert swivel block (H, Figures 2-3 & 2-5) on wheel drive control rod into wheel drive control arm (U, Figure 2-3).
- Add one 5/16" washer (A, Figure 2-3). Secure with cotter pin (B, Figure 2-3). Bend ends of cotter pin to secure.
- At upper end of control rod, secure angled end to Wheel Drive Control lever (V, Figure 2-4), using a cotter pin (BB). Bend ends of cotter pin to secure.

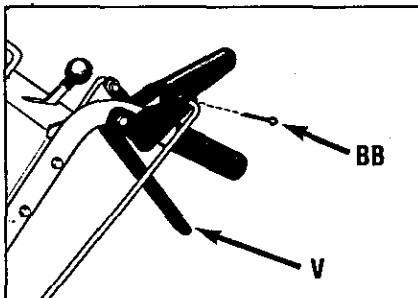

Figure 2-4: Attach wheel drive control rod to lever.

### B. Attach Operator Presence Control Rod:

- Locate control rod (E, Figures 2-3 & 2-5) attached at upper end to Operator Presence Control (W, Figure 2-5).
- At bottom of control rod, insert swivel block (G, Figures 2-3 & 2-5) into control arm (T, Figure 2-3).
- Add one 5/16" washer and secure with cotter pin. Bend ends of cotter pin to secure.

### C. Attach Blade Drive Control Rod:

- Locate the blade drive control rod (C, Figure 2-5) that you removed in Step 1. Insert one end of control rod into blade drive bracket (D, Figure 2-5). Add one 5/16" washer and secure with cotter pin (CC). Bend ends of cotter pin to secure.
- Insert upper end of rod into bottom end of Blade Drive Control lever (J). Add one 5/16" washer and secure with cotter pin (AA). Bend ends of cotter pin to secure.

### D. Attach and Adjust Gear Select Lever:

- To remove unit from shipping crate, hold down Operator Presence Control lever (W, Figure 2-5) which releases the wheel brake.
- Using the edge of a piece of flat wood (such as a ruler), remove the vinyl grip (B, Figure 2-6) from the gear select lever (I). Place the wood edge against the edge of the grip and slowly pull off the grip.
- Insert nylon bushing (Z, Figure 2-6) up into console (L).
- Slide spring and washers (J) down onto gear select lever.
- Insert gear select lever (I) up through nylon bushing (Z) in handlebar console (L, Figure 2-6). Guide pin (K) on gear select lever into groove in shift quadrant (EE).
- Hold lower part of gear select lever (I) against bracket (M, Figure 2-7). Position retaining plate (N) from parts bag in place as shown in Figure 2-7 (plate below bracket). Secure plate with two 1/4"-20 x 1/2" long screws (O) and 1/4"-20 locknuts.
- Slide grip (B, Figure 2-6) back onto upper end of gear select lever (I).

# ASSEMBLY

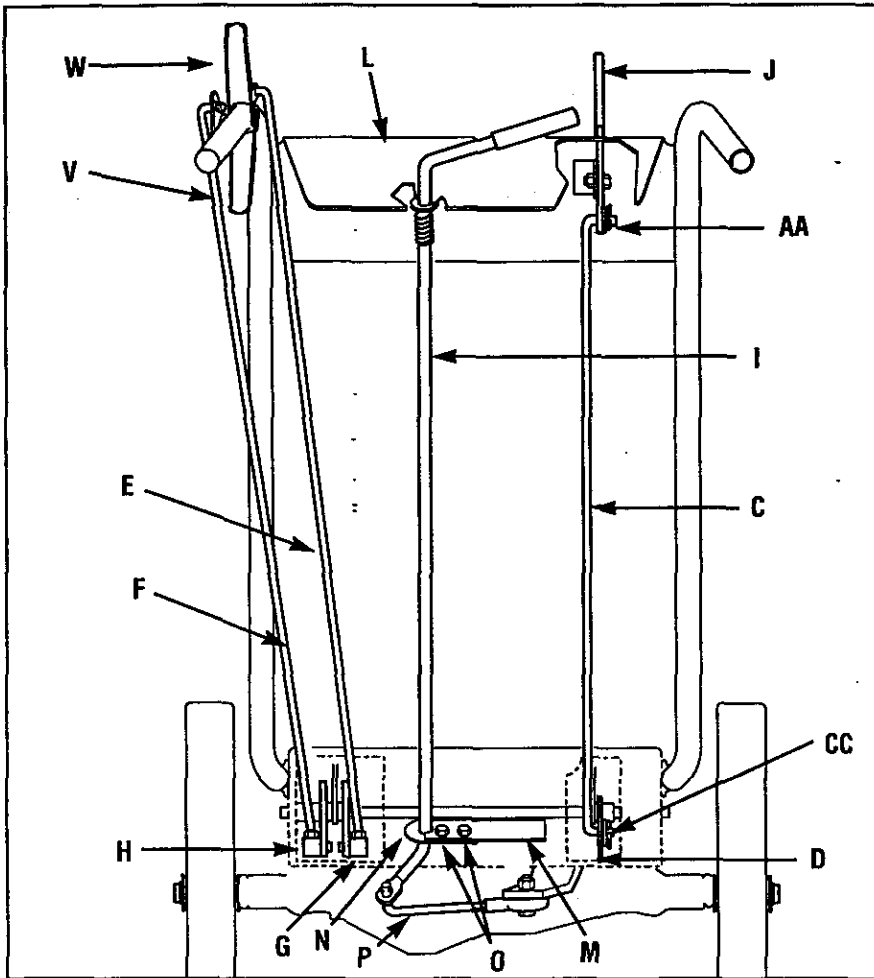

Figure 2-5: Rear view of control rods.

- Rotate gear select lever (I, Figures 2-6 & 2-7) clockwise until pin (K) on gear select rod stops in the neutral position detent on the shift pattern quadrant (Figure 2-6).
- Thread shift link (P, Figure 2-7) partially into ball-joint (Y).
- Move shift arm (X, Figure 2-7) from side to side as necessary into each transmission gear detent until transmission is in neutral.  
**NOTE:** Moving shift arm (X) all the way to the left, and then one notch back to the right, should put transmission into neutral. When transmission is in neutral, unit will move freely when pushed while holding the Operator Presence Control lever (W, Figure 2-5) down. If transmission is NOT in neutral, there will be a slight drag on the wheels when pushing unit.
- When shift arm (X) is in neutral position, rotate shift link (P) toward end of gear select lever rod (I). Adjust length of shift link (P) as necessary to fit into hole in bottom of gear select lever (I).  
**NOTE:** Pin (K) on Gear Select Lever (I) must be held in the neutral position detent on the shift quadrant (see Figure 2-6) while shift link (P, Figure 2-7) is adjusted.

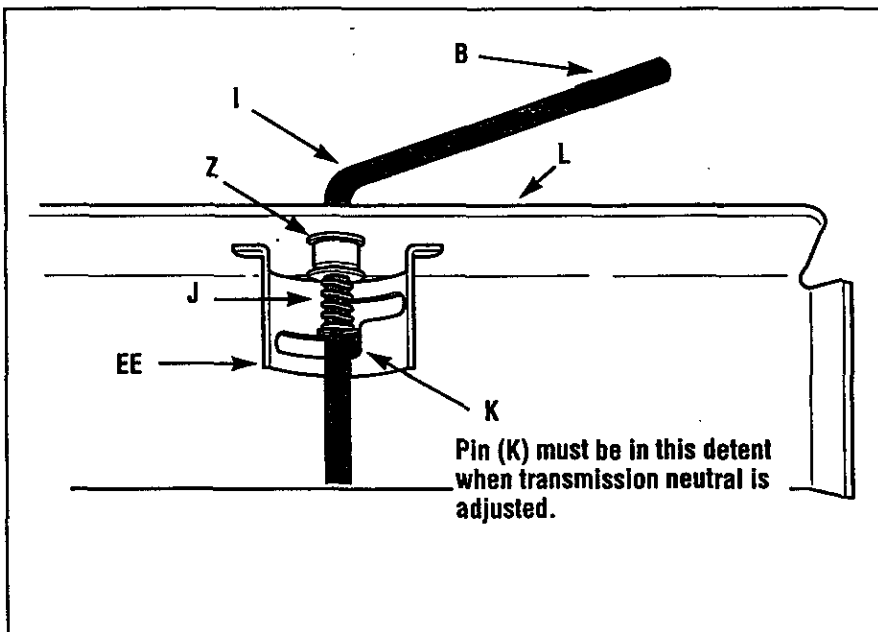

Figure 2-6: Detail - Gear Select Lever in Neutral (N) position.

# ASSEMBLY

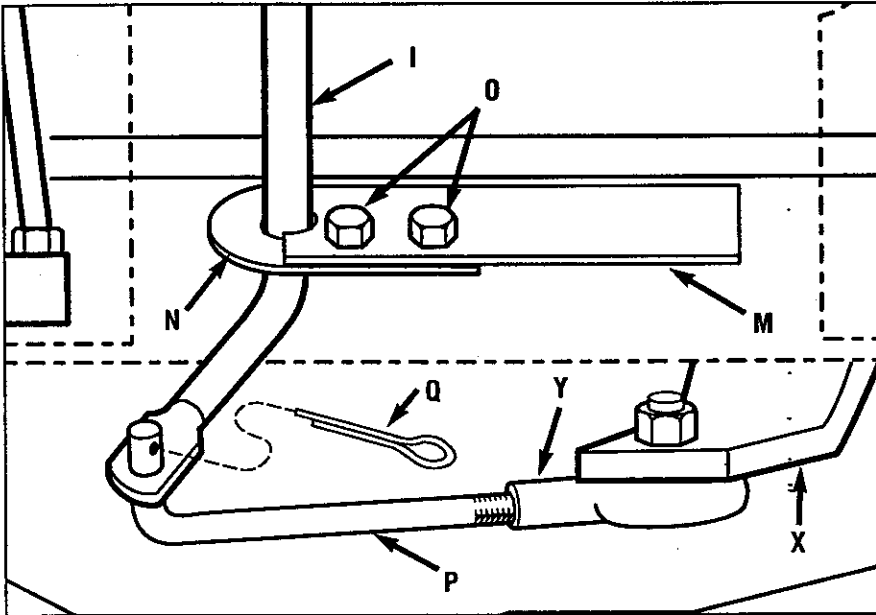

Figure 2-7: Detail – Transmission Neutral Adjustment.

- Insert hooked end of shift link (P, Figure 2-7) into hole in bottom end of gear select lever (I) and secure with cotter pin (Q). Bend ends of cotter pin. **NOTE:** It may be necessary to lift gear select lever (I) to install shift link (P).
- Hold down Operator Presence Control lever (W, Figure 2-5) and push unit forward and backward. The wheels should move freely. If not, adjust length of shift link (P, Figure 2-7) as necessary.

## E. Test Wheel Brake:

Put the Gear Select Lever in in neutral (N), release all of the control levers, and try to push the unit forward and backward. The wheels should not turn. If they do turn, an adjustment is necessary.

**DO NOT OPERATE THE UNIT UNTIL THE WHEEL BRAKE MECHANISM HAS BEEN ADJUSTED AND IS WORKING PROPERLY.** See "Wheel Brake Adjustment" in "Customer Responsibilities."

## WARNING

Do not use the mower if the wheels continue to turn after releasing the Operator Presence Control and the Wheel Drive Control. Severe personal injury or property damage could result if this instruction is not followed.

## WARNING

The control rods are adjusted at the factory and should not require additional adjustment during assembly. After assembling unit, control rod adjustment should be checked (and re-adjusted, if necessary) according to information in "Customer Responsibilities" Section. Severe personal injury or property damage could result from not following this instruction.

## STEP 3: Check Tire Pressure

- Use a tire gauge to check the air pressure in the rear tires. The air pressure should be between 15-20 PSI (20 PSI maximum).
- Keep both tires equally inflated to help prevent machine from pulling to one side.

## STEP 4: After Assembling and Before Using Unit

- Read this entire Owner's Manual for proper safety, operation and maintenance information.
- Make sure spark plug wire is connected to spark plug before starting unit.

**IMPORTANT: MOTOR OIL MUST BE ADDED TO THE ENGINE CRANKCASE BEFORE STARTING THE ENGINE. OIL FILLING INSTRUCTIONS ARE COVERED IN THE "OPERATION" SECTION.**

## CAUTION

Unit is shipped without oil in engine crankcase. **DO NOT** start engine until oil has been added. Severe engine damage will result if this instruction is not followed. See "Operation" Section of this manual for oil filling procedure.

# OPERATION

## KNOW YOUR EQUIPMENT

READ THIS OWNER'S MANUAL AND ALL SAFETY RULES BEFORE OPERATING YOUR EQUIPMENT. Know the location and function of all features and controls on the equipment. Save this manual for future reference.

### MEETS ANSI B71.1 – 1996 SAFETY STANDARD

This machine meets voluntary safety standard B71.1 – 1996, which is sponsored by the Outdoor Power Equipment Institute, Inc., and is published by the American National Standards Institute, Inc.

### Operating Symbols

Various symbols are used on the mower to indicate control settings (your model may not have all of the symbols). These symbols are shown below with a description of their meaning.

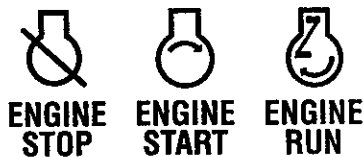

**IMPORTANT:** The mower is equipped with a blade-brake-clutch control system which is designed to stop the mower blades within three (3) seconds after release of the Operator Presence Control. This system will stop the blades but not the engine. Therefore, you can disengage the blade drive at anytime without having to stop and restart the engine. This feature is particularly useful when you need to cross gravel drives or rough terrain and you do not want the spinning blades to strike stones or hidden obstacles.



### WARNING

The blade-brake-clutch control system should stop the mower blades within three (3) seconds after release of the Operator Presence Control. If the blades do not stop within three (3) seconds, put the Engine Throttle Control in the STOP position. Disconnect the spark plug wire and do not operate the mower until the blade-brake-clutch control system has been repaired.

### LOCATION AND USE OF CONTROLS



### Operator Presence Control

This lever (A, Figure 3-1) regulates the operation of the rear wheel brake and the separate Blade Drive Control.

To engage the Operator Presence Control, press and hold the lever against the handlebar grip. Engaging the lever releases the brake on the rear wheels (allows wheels to turn). The engaged position also permits the separate Blade Drive Control to lock in its engaged position (allows the mower blades to turn).

Releasing the lever (disengaged position) applies the rear wheel brake and quickly stops the wheels. Releasing the lever will also disengage the Blade Drive

Control, which will apply a brake that stops the blades within three (3) seconds.

Always disengage the Operator Presence Control before starting the engine. Always engage this control before engaging the separate blade drive or wheel drive controls.

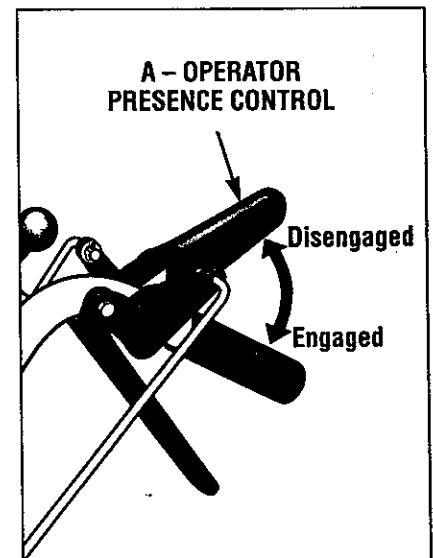

Figure 3-1

# OPERATION

## Blade Drive Control

Use this lever (B, Figure 3-2) to engage drive to the mower blades.

To engage the blades, first engage the Operator Presence Control (A, Figure 3-2). Then, push the spring-loaded Blade Drive Control lever (B) forward until it stays in the engaged position.

To stop the blades, release the Operator Presence Control (A). Doing so will disengage the Blade Drive Control (B) and automatically apply the brake that stops the blades.

When starting the engine, the Blade Drive Control should be disengaged (released). This helps to ensure that the blades will not start turning when the engine starts.

**NOTE:** Pushing the Blade Drive Control forward will engage the blades even though the Operator Presence Control is not engaged. However, this procedure is **NOT RECOMMENDED** as you must maintain constant pressure on the

lever (releasing lever disengages blades). Always engage the Operator Presence Control before engaging the Blade Drive Control.

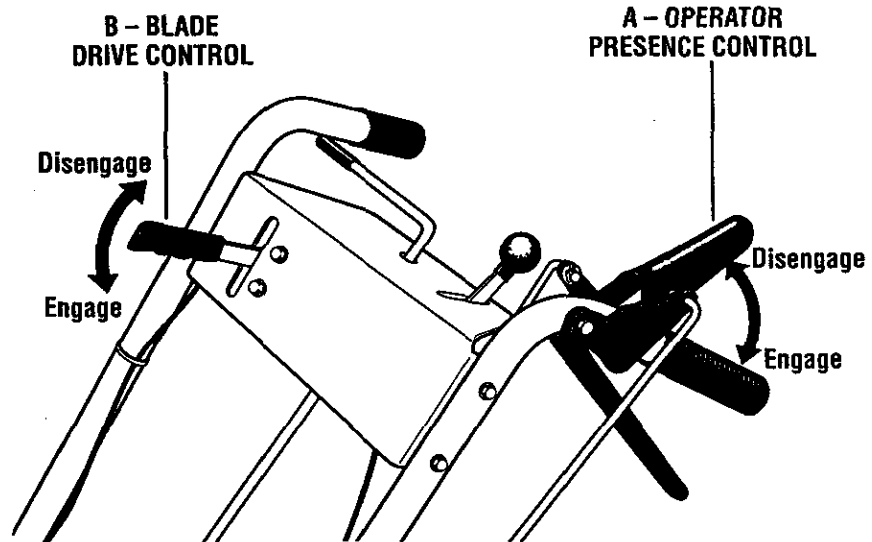

Figure 3-2

## Gear Select Lever

This lever (C, Figure 3-3) is used to select any of three forward ground speeds (1 - Slow, 2 - Medium and 3 - Fast), N (Neutral) and R (Reverse). The gear shift pattern is shown in Figure 3-4.

**To avoid damaging the transmission, do not shift gears when the mower is moving.** Select forward ground speeds according to mowing conditions and terrain (use slower speeds in high grass or on rough terrain).

For forward travel, move the lever into one of the three numbered settings. To select reverse, shift to neutral and then pull up on the lever. Turn the lever to the R (reverse) position and release the lever.

Put the lever in N (neutral) to manually push the mower and when the mower is not in use.

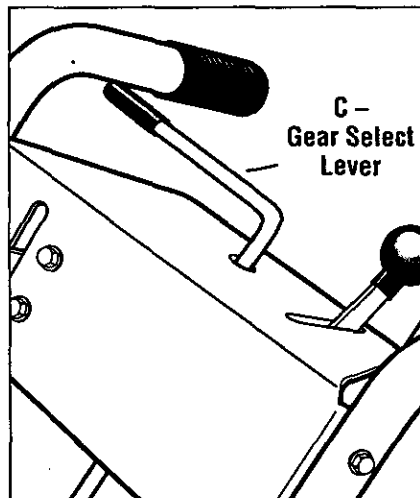

Figure 3-3

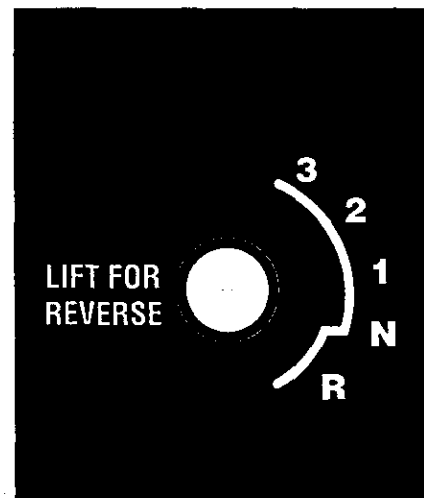

Figure 3-4: Shift pattern on console.

# OPERATION

## Wheel Drive Control

Use this lever (D, Figure 3-5) to engage and disengage drive to the wheels.

To engage the wheels, first select a forward or reverse gear with the Gear Select Lever and press the Operator Presence Control (A, Figure 3-5) against the handlebar grip. Then, squeeze the Wheel Drive Control lever (D) up against the handlebar grip. The ground speed can be varied in any gear by increasing (to go faster) or decreasing (to go slower) pressure on the lever. **To avoid sudden acceleration, slowly squeeze the lever when first engaging the wheels.**

Release the Wheel Drive Control to disengage the wheels. The

wheels will gradually slow to a stop. **NOTE:** To stop the wheels quickly, release the Operator Presence Control along with the Wheel Drive Control.

When starting the engine, the Wheel Drive Control should be disengaged (released). This helps to ensure that the wheels will not start turning when the engine starts.



### CAUTION

Do not engage the Wheel Drive Control without first engaging the Operator Presence Control. Doing so could result in wear or damage to the wheel brake mechanism.

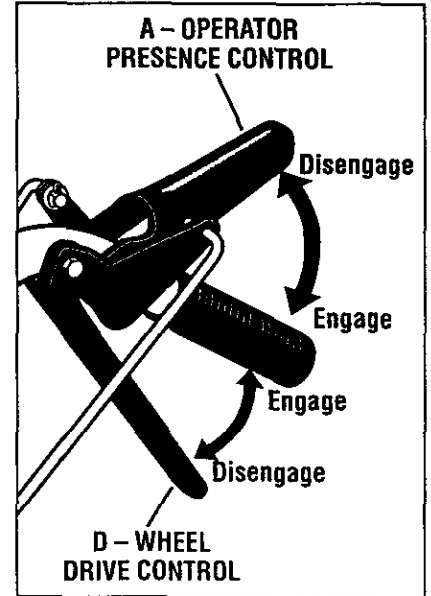

Figure 3-5

## Cutting Height Control Lever

This lever (E, Figure 3-6) is used to adjust the mower cutting height. The cutting height can be adjusted from 1 to 4 inches.

Turn the lever clockwise to raise the cutting height or counterclockwise to lower the cutting height. A decal and pointer (not illustrated)

on the right side of the mower deck show the cutting height settings ranging from A (highest) to G (lowest). Note that the actual cutting heights will vary according to soil conditions.

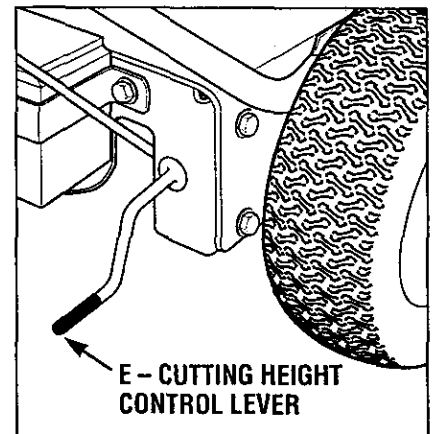

Figure 3-6

## Mulcher Cover

To use the mulching feature, insert the mulcher cover (Figure 3-7) securely in the right side of the deck beneath the discharge chute.

Insert the front tab of the cover into the mower front support bracket (AA, Figure 3-7). Then push the cover into place by sliding the cover rearward, making sure that the slot (BB) in the cover is completely engaged in the rear edge of the deck opening.

Remove the mulcher cover if you want to do side-discharge mowing.

The mulcher cover is pre-installed at the factory.

**NOTE:** The mulcher cover is designed to keep the discharge chute raised up while you mow. When the cover is removed, the discharge chute lowers.



### DANGER

Before installing or removing mulching cover, stop engine, wait for parts to stop moving, and disconnect spark plug wire.

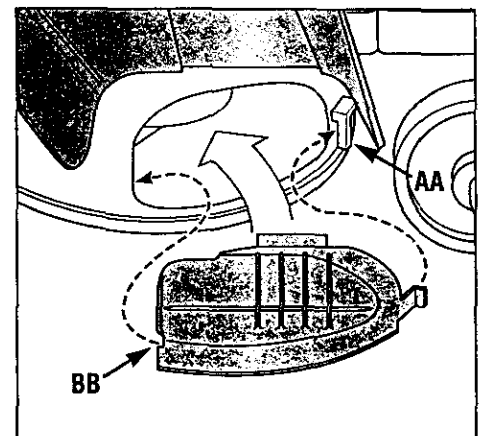

Figure 3-7

# OPERATION

## Engine Throttle Control

This lever (F, Figure 3-8) is used to adjust engine speeds and to stop the engine. Always run engine at fast speed setting for best mower performance. The throttle settings are shown to the right.



**CHOKE** - Use when starting a cold engine.



**FAST** - Use during mower operation.



**SLOW** - Use when idling engine.



**STOP** - Stops engine.

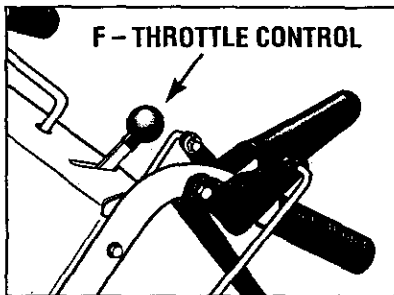

Figure 3-8

## Engine Recoil Starter

The engine recoil starter (H, Figure 3-9) is used to "pull-start" the engine. Do not pull the recoil starter until you have read the Operation Section.

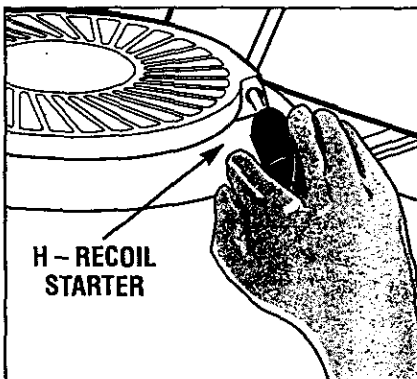

Figure 3-9

## BEFORE OPERATING

### Pre-Operation Checklist



Perform the following checks before each use of your machine:

- Review: "Safety" and "Operation" sections of manual.
- Check for loose or missing hardware. Tighten or replace before starting engine.
- Check the engine oil level. Refer to "Customer Responsibilities" section for instructions.
- Check the fuel level in the fuel tank (refer to next page for instructions).
- Check all levers for freedom of movement. Do not start engine if any lever does not function correctly.
- Adjust the blade cutting height (refer to this Section for instructions).
- Inspect the area to be mowed and remove any debris.
- Check that all guards and shields are in place and properly secured.
- Check the installation of the mulcher cover in the right side deck opening. Remove the mulcher cover if you want to side discharge the grass.
- Check air pressure in rear tires at first use and every 25 operating hours. Maintain 15-20 PSI (maximum 20 PSI) in each tire. Keep tires inflated equally or mower may pull to one side.
- Attach the spark plug wire to the spark plug.



# OPERATION

## BEFORE STARTING ENGINE

### Add Motor Oil

- Only use high quality detergent oil rated with API service classification SF, SG or SH. Select the oil's SAE viscosity grade according to your expected operating temperature. Above 32°F, use SAE 30; below 32°F, use 5W30.

NOTE: Although multi-viscosity oils (5W30, 10W30 etc.) improve starting in cold weather, these oils will result in increased oil consumption when used above 32°F. Check engine oil more frequently to avoid possible engine damage from running low on oil.

- Be sure that engine is level. Remove dipstick (A, Figure 3-10).
- Fill with recommended oil to between "Full" and "Add" marks on dipstick (approximately 32 oz.). Pour slowly and do not overfill. While pouring, stop frequently, re-insert dipstick until it is seated completely, remove and check oil level. (Wipe dipstick each time before re-inserting.) Replace dipstick securely.
- Check oil before each use. Add if needed.
- Change oil after the first 2 operating hours and every 25 operating hours thereafter (more often in extremely dusty or dirty conditions).

### Fill Fuel Tank

- Stop engine and allow it to cool for three minutes before removing fuel fill cap (B, Figure 3-10). Do not check fuel level or add fuel while indoors.
- Clean area around fuel fill cap and remove fill cap. Fill gas tank with clean, fresh unleaded gasoline. Do not mix oil with gasoline.
- Using a funnel or spout, fill tank to 1/2 inches below bottom of fuel tank filler neck to prevent spills and to allow for fuel expansion.
- Install fill cap securely and wipe up any spilled gasoline.

WARNING: Experience indicates that alcohol blended fuels (gasohol or using ethanol or methanol) can attract moisture which leads to separation and formation of acids during storage. Acidic gas can damage the fuel system of an engine while in storage. To avoid problems, the fuel system should be emptied before storage for 30 days or longer. Drain the gas tank, start the engine and let it run until the fuel lines and carburetor are empty. Use fresh fuel next season. See STORAGE instructions for additional information. Never use engine or carburetor cleaner products in the fuel tank or permanent damage may occur.

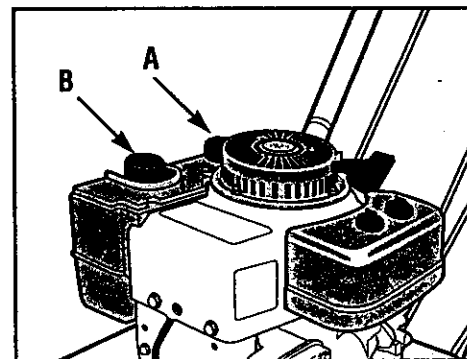

Figure 3-10



### DANGER

Gasoline is highly flammable and its vapors are explosive. Read and follow these precautions to help avoid severe personal injury or property damage.

- Do not remove gas cap or add gasoline if engine is running or still hot from operation. Allow engine to cool at least three minutes before refueling.
- Keep open flame, matches, sparks, or smoking materials away from fuel tank and fuel container.
- Do not fill fuel tank indoors. After filling, wipe up any spills and move machine away from gasoline fumes before starting engine. Securely replace the caps on the fuel tank and fuel container.
- Do not fill fuel tank completely. Fill tank to 1/2" below bottom of filler neck to provide space for fuel expansion.
- Store gasoline in an approved fuel container and in a well-ventilated area. Store it safely out of the reach of children.
- Do not store gasoline where vapors may reach an open spark or flame, or where ignition sources (such as hot water heaters, space heaters, furnaces, clothes dryers, stoves, electric motors, etc.) are present.

# OPERATION

## Adjust Mower Cutting Height

The cutting height can be adjusted from 1 to 4 inches by rotating the Cutting Height Control lever (A, Figure 3-11).

Choose cutting heights according to grass conditions and terrain. In heavy or tall grass, it is usually better to make the first cut at a higher setting and then make a second cut at the desired setting. When mowing in rough terrain, a higher setting is recommended as it will minimize the chances of the blade striking the ground or hidden obstructions.

1. Release all mower controls before adjusting cutting height.
2. Turn Cutting Height Control lever clockwise to raise cutting height or counterclockwise to lower cutting height. A decal and pointer (not illustrated) on the right side of the mower deck show cutting height settings ranging from A (highest) to G (lowest). Note that actual cutting heights will vary according to the grass and soil conditions.

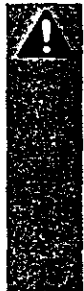

### CAUTION

To avoid personal injury, do not adjust cutting height while wheels or blades are turning. Release all handlebar controls and wait for all motion to stop before adjusting cutting height.

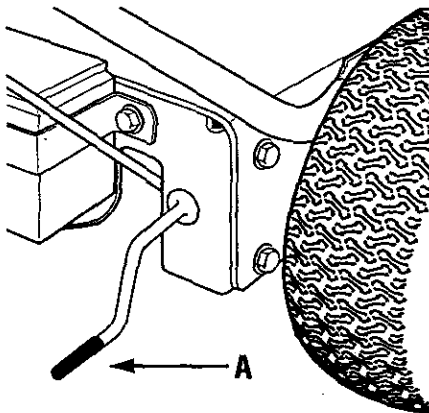

Figure 3-11: Cutting Height Control lever.

## Test Blade-Brake-Clutch Control System

The mower is equipped with a blade-brake-clutch which is designed to stop the mower blades within three (3) seconds after release of the Operator Presence Control or the Blade Drive Control. Never tamper with, or attempt to defeat the purpose of this safety device.

The control system is a mechanical device which is subject to wear. Therefore, test the operation of the blade-brake-clutch control system before each use of the mower. Refer to "Blade Brake Control Test" at the end of this Section.

## Select Mulching or Side-Discharge Mowing

Your combination mower allows you to select either mulching or side-discharging of the grass clippings. To use the mulching feature, insert the mulcher cover. Remove the cover if side discharge mowing is desired. Refer to "Mulcher Cover" on Page 15 for installation instructions.

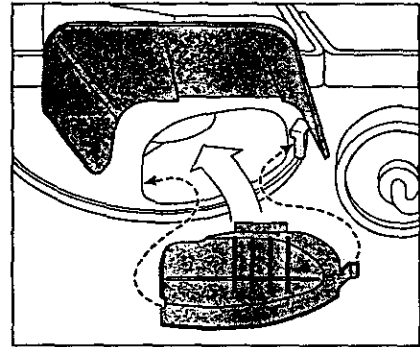

Figure 3-12: Mulcher cover.



### DANGER

Before installing or removing mulching cover, stop engine, wait for parts to stop moving, and disconnect spark plug wire.

## MOVING THE MOWER WITHOUT ENGINE POWER

The mower can be manually pushed or pulled by putting the Gear Select Lever (C, Figure 3-13) in N (neutral) and pressing and holding the Operator Presence Control (A, Figure 3-13) down against the handlebar grip.

To stop the wheels at anytime, release the Operator Presence Control.

# OPERATION

## STARTING AND STOPPING THE ENGINE



### DANGER

Do not operate engine in an enclosed area. Engine exhaust contains carbon monoxide, a deadly gas that is odorless, colorless and tasteless. Always run engine outdoors and make sure there is adequate ventilation.

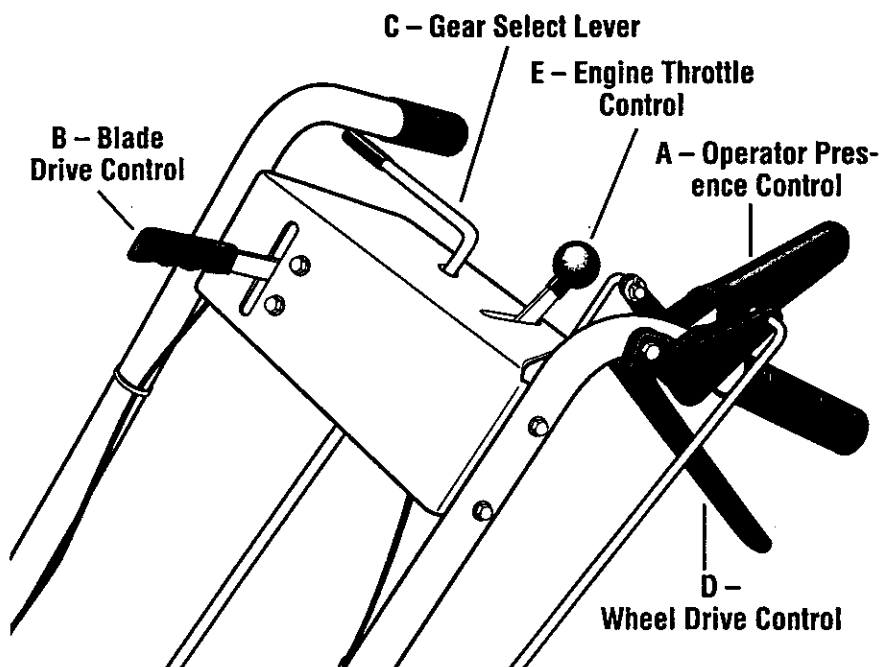

Figure 3-13: Mower Controls.



### WARNING

To avoid injury:

- Keep hands and feet clear of mower blades or other rotating parts.
- Look behind you to be sure there are no obstacles before pulling recoil starter rope.

### To Start the Engine

1. Move mower to a level area.
2. Release all controls on mower to prevent wheels or mower blades from rotating when engine starts.
3. Move Engine Throttle Control (E, Figure 3-13) fully upward to choke setting to start a cold engine or to fast (rabbit) setting to start a warm engine.

4. To start engine using recoil starter:
  - A. Stand on left side (as viewed from behind handlebars) of machine. Be sure your feet are safely away from the underside of the mower deck and all mower controls are released. Place one foot on top of tire.
  - B. Grasp rope handle (G, Figure 3-13) and pull slowly until rope pulls slightly harder. Let rope rewind slowly. Then pull rope with a rapid, full arm stroke. Let rope return slowly. If engine fails to start after three pulls, repeat instructions starting with Step 2 (try setting throttle at fast setting).
  - C. When engine starts, operate in fast throttle setting (move throttle from choke setting to fast setting).

### To Stop the Engine

1. Release all mower controls to stop wheels or mower blade.
2. Move throttle control down to slow (turtle) position. (Whenever possible, gradually reduce engine speed before stopping engine.)
3. Move Throttle Control all the way down to stop position.

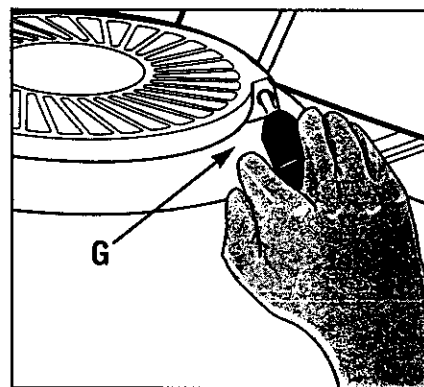

Figure 3-14: Engine recoil starter.

## ENGAGING THE BLADES



### DANGER

To avoid injury from rotating blades, keep face, hands and feet clear of mower blades at all times.

### To Engage the Blades

1. Start engine as described in "To Start the Engine" instructions. Put engine throttle in fast speed setting.
2. Press and hold Operator Presence Control (A, Figure 3-13) against handlebar grip.
3. Slowly push Blade Drive Control (B, Figure 3-13) fully forward until it stays in the engaged position. The blades are now rotating.

### To Stop the Blades

To stop the blades, release the Operator Presence Control.

# OPERATION

## TO ENGAGE THE WHEELS



### CAUTION

- To avoid damaging the transmission, do not shift gears while in motion.
- To avoid damaging the wheel brake mechanism, do not engage the Wheel Drive Control without first engaging the Operator Presence Control.



### WARNING

Before engaging the Wheel Drive Lever for the very first time, check that the neutral (N) position on the Gear Select Lever is properly adjusted. See "Neutral Adjustment" in "Service and Adjustments" Section for the procedure to follow.

Failure to follow this instruction could result in personal injury or property damage.

1. Start engine as described in "To Start the Engine" instructions.

### 2. FOR FORWARD TRAVEL:

- A. Press and hold Operator Presence Control (A, Figure 3-13) against handlebar grip.
- B. Put the Gear Select Lever (C, Figure 3-13) into one of the numbered settings (1 - Slow, 2 - Medium and 3 - Fast). When first practicing with the mower, put lever in No. 1 setting. Select forward speeds according to mowing conditions and terrain. Use slower speeds on rough terrain or when grass is heavy or thick. The forward speed can be increased on smooth terrain or if the grass cover is light. Allow the wheels to stop completely before shifting from one forward speed into another.

C. To start the wheels, slowly squeeze the Wheel Drive Control (D, Figure 3-13). The harder you squeeze, the faster the wheels will turn. To avoid sudden acceleration, slowly squeeze the lever.

### D. TO STOP THE WHEELS:

- To stop drive power to the wheels, release the Wheel Drive Control. The wheels will gradually slow to a stop.
- To quickly stop the wheels, release **both** the Wheel Drive Control and the Operator Presence Control.



### WARNING

To avoid injury or property damage:

- Look behind mower before and during reverse operation.
- Stop the mower blades before operating in reverse.

### 3. FOR REVERSE TRAVEL:

A. Stop the mower blades and wheels by releasing the Operator Presence Control (A, Figure 3-13).

B. Press and hold Operator Presence Control against handlebar grip.

C. Put the Gear Select Lever (C, Figure 3-13) in R (reverse) setting by first moving lever to N (neutral). Then pull lever up, turn it to R position, and release lever.

D. To start the wheels, slowly squeeze Wheel Drive Control (D, Figure 3-13). To avoid sudden acceleration, slowly squeeze the lever.

### E. TO STOP THE WHEELS:

- To stop drive power to the wheels, release the Wheel Drive Control. The wheels will gradually slow to a stop.
- To quickly stop the wheels, release **both** the Wheel Drive Control and the Operator Presence Control.
- Return the Gear Select Lever to the N (neutral) position when you have completed reverse operation. Allow the wheels to stop completely before shifting from R (reverse) into a forward speed.

## MAKING TURNS

The mower turns easily by pushing the handlebars in the opposite direction that you want to turn. The differential mechanism inside the transaxle will allow the inside turning wheel to stop or slow down while the outside turning wheel is powered by the drive system.

Reduce the wheel speed before turning the mower. For tight turns, disengage the Wheel Drive Control and manually push the mower through the turn (if needed, put the Gear Select Lever in neutral so the wheels turn freely).

# OPERATION

## MOWING TIPS AND HINTS



### WARNING

To avoid injury or property damage:

- Before mowing, thoroughly inspect area where mower is to be used and remove all stones, sticks, wires, bones, nails and other foreign objects.
- Disengage mower blades before crossing gravel drives, roads, or sidewalks to prevent blades from throwing stones or other hazardous objects.

### Mow When Lawn Is Dry



For best results, avoid cutting grass when it is wet. Wet grass tends to form clumps which interfere with the cutting action. The best time to mow is in the late afternoon or early evening when the grass is usually dry.

### Cut Top 1/3 of Grass Blades

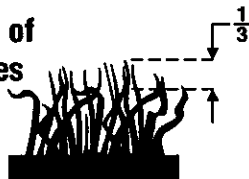

Cutting more than 1/3 of grass length may cause the grass to become excessively dry. In tall grass, it may be necessary to mow at a higher setting and then mow again at the desired height. NOTE: The cutting height is critical to achieving a well-groomed lawn. You should experiment with various settings to find that "just right" cutting height.

### Vary Cutting Pattern



Vary the cutting pattern from week to week to help prevent matting of the grass. One week, mow from north to south, the next week mow from east to west. Overlap several inches when mowing to obtain an even appearance.

### Mowing on Slopes



Do not mow excessively steep slopes (see WARNING statement below). Slow down and exercise extreme caution when changing direction on slopes. Before mowing on slopes, check the engine oil level and make sure that the level is at the FULL mark. Maintaining a FULL oil level is particularly important when operating on slopes as oil can be drained away from vital engine parts.



### WARNING

To avoid injury or property damage:

- Maximum safe operating angle is 15°.
- Exceeding maximum safe operating angle may cause tipping or loss of footing.
- Do not mow wet slopes.
- Mow across slopes, not up and down.
- Exercise extreme caution when changing direction on slopes.

### Mulching Leaves

- The mower can also be used to mow leaves in the fall. The leaf particles filter down into the lawn and provide added fertilizer.
- The leaves must be dry in order to be mulched.
- Use a slower ground speed if the leaves are not mulched into fine particles.
- If you mulch oak leaves (which add acid to the soil), add lime to the lawn in the spring to reduce the acidity of the soil.

### Keep Mower Blades Sharp

For best mower performance, keep the blades sharp. A dull blade will tear, bruise and split the ends of grass.

### Clean Mower Frequently

Clean the underside of the mower deck frequently to remove grass build-up.

### Precision Trimming

For precision trimming, use the slowest gear and inch the mower along by "feathering" the Wheel Drive Control lever. Or, disengage the wheel drive by releasing the Wheel Drive Control so that you can manually maneuver the mower (if needed, put the Gear Select Lever in neutral so that the wheels turn freely).

### Mowing Ditches

If you have to mow ditches, stop the engine and adjust the cutting height to its highest setting. Mow in the direction of the ditch. Mow both sides of the ditch first, and then mow the bottom. When mowing ditches, watch out for cans, bottles, or other debris.

# OPERATION

## BLADE BRAKE CONTROL TEST

When the Operator Presence Control is released during operation of the mower, the engine does not stop, but the blades should stop within three (3) seconds. The following test provides a visual test of whether the Blade Brake Control System is functioning. Perform this test before each use of the mower.



### WARNING

To avoid personal injury or property damage, make sure that the mower is on grass, and that the test area is clear of foreign objects and bystanders before you begin the Blade Brake Control Test.

If the Operator Presence Control or the Blade Drive Control are not adjusted correctly, the blades may continue to rotate after release of the Operator Presence Control. If the blades do not stop within three (3) seconds of release of the Operator Presence Control, move the Engine Throttle Control to the STOP position, disconnect the spark plug wire, and move the wire away from the spark plug. Do not operate the mower until the Blade Brake Control System has been repaired.

Failure to do this could result in personal injury or property damage.

1. Park mower on a portion of lawn which has not been recently mowed.
2. Set the cutting height so the mower cuts 1/3 of the grass height.
3. Start the engine.
4. Press the Operator Presence Control down against the handlebar grip and push the Blade Drive Control fully forward until it stays in the engaged position.
5. Put the Gear Select Lever in the No. 1 setting.
6. Engage the wheels with the Wheel Drive Control and drive the mower for several feet. Then release the Operator Presence Control.
  - A. Look at the lawn just mowed. The lawn should be cut up to the point where the Operator Presence Control was released.
  - B. Press the Operator Presence Control against the handlebar grip but DO NOT re-engage the Blade Drive Control. Drive the mower forward for several more feet. Release the Operator Presence Control and look at the lawn. The grass should NOT have been cut. This indicates that the Operator Presence Control has disengaged the blade drive and stopped the blades.
7. If the mower cuts the grass in Step 6-B, the Operator Presence Control is NOT disengaging the blade drive. **Immediately stop the engine, disconnect the spark plug wire, and move the wire away from the spark plug.**
8. Do not use the mower until the Blade Brake Control System has been inspected, adjusted or repaired by a Sears Service Center.

# CUSTOMER RESPONSIBILITIES

## Maintenance Chart

INTERVAL*	ITEM	SERVICE
Each use	Mower Blade Loose or Missing Hardware Belts Engine Oil Level Controls Mulching Cover	As Required Tighten or Replace Check Check Check for Proper Operation Check for Proper Cover Installation
1st 2 hours	Engine Oil	Change
25 hours	Engine Oil**** Foam Air Filter*** Mower Blade(s) Control Linkages and Pivots	Change Clean Sharpen and Balance Lube with Light Oil
50 hours	Engine Oil Blade Drive Belt Adjust Engine Cooling Fins Grease Fittings**	Change Adjust Tension Clean Grease
Annually or 100 hours	Air Filter Element*** Spark Plug	Replace Clean/Replace, Re-gap
Monthly	Linkages Belts	Adjust Check/Replace, Adjust
Annually or 50 hours	Front Wheel Bearings	Grease

\*Interval describes running time.

\*\*A hand-type grease gun is recommended when greasing your unit. High-pressure type grease guns could cause damage to fittings/seals.

\*\*\*Clean more often under dusty conditions or when airborne debris is present. Replace air cleaner parts, if very dirty.

\*\*\*\*Change more often under dusty conditions.

## Lubrication Chart

ITEM	INTERVAL	LUBRICATION TYPE
Engine Crankcase	First 2 hours	Change Oil
	25 hours (more often in dusty conditions)	Change Oil (Lubrication Intervals Vary with Operating Conditions and Type of Oil Used)
Front Wheel Bearings	50 hours	Grease (1-3 Strokes)
Control Linkages/Pivots	25 hours	Light Oil (A few drops)

\* A hand-type grease gun is recommended.

### LUBRICATION

Oil and grease the mower according to the recommendations listed in the Lubrication Chart.

• **Stop engine, wait for all parts to stop moving, and disconnect spark plug wire before performing any lubrication procedures.**

• The transmission has been factory sealed and requires no lubrication. If a leak should develop, contact your local Sears Service Center.

# CUSTOMER RESPONSIBILITIES

## GENERAL RECOMMENDATIONS

The warranty on this equipment does not cover items that have been subjected to operator abuse or negligence. To receive full value from the warranty, the operator must maintain the equipment as instructed in this manual.

Some adjustments will need to be made periodically to properly maintain your equipment.

All adjustments in the Service and Adjustments section of this manual should be checked at least once each season.

Keep the air filters clean and change the spark plug once a year. A clean air filter system and a new spark plug will help your engine run better and last longer.

### Before Each Use

- Check engine oil level.
- Check all hardware for tightness.
- Check that all guards and shields are in place and properly secured.

## MOTOR OIL

- Only use high quality detergent oil rated with API service classification SF, SG or SH. Select the oil's SAE viscosity grade according to your expected operating temperature. Above 32°F, use SAE 30; below 32°F, use 5W30.

NOTE: Although multi-viscosity oils (5W30, 10W30 etc.) improve starting in cold weather, these oils will result in increased oil consumption when used above 32°F. Check engine oil more frequently to avoid possible engine damage from running low on oil.

### Checking Oil Level

Engine oil level must be between "ADD" and "FULL" marks on dipstick at all times. Check before each use and every 5 operating hours.

1. Park machine on level ground.

2. Stop engine, wait for parts to stop moving, and disconnect spark plug wire.

3. Clean area around dipstick (Z, Figure 5-1) to prevent dirt from entering oil fill hole.

4. Remove dipstick. Oil level must be between "ADD" and "FULL" marks. Do not exceed "FULL" mark on dipstick.

5. To add oil, pour slowly into dipstick opening. While adding, check oil level frequently by securely replacing dipstick and removing to read oil level. Wipe dipstick clean each time oil level is checked.

6. After filling to "FULL" mark, securely replace dipstick.

## Changing Oil

Change oil after the first 2 operating hours and every 25 operating hours thereafter. Change oil while engine is still warm from recent operation. Warm oil flows more freely and carries away more impurities.

1. Stop engine, wait for parts to stop moving, and disconnect spark plug wire.

2. Remove dipstick (Z, Figure 5-1).

3. Remove protective cap (A, Figure 5-2) to expose oil drain port (B).

4. Push oil drain hose (D) (included in hardware bag with unit) onto oil drain port. Route other end of hose to an appropriate oil collection receptacle.

5. Twist oil drain fixture (C) to the open position. Pull out. Drain oil completely.

6. Push in and twist oil drain fixture to the closed position. Remove drain hose. Replace protective cap (A).

7. Refill engine with fresh oil and securely replace dipstick.

NOTE: Please dispose of all waste materials in an ecologically responsible manner. Use proper waste material storage containers.

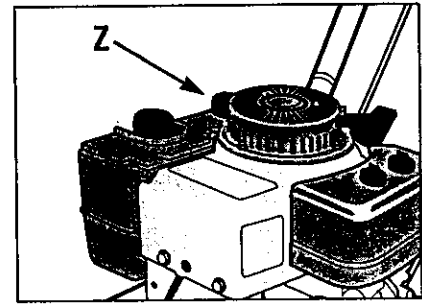

Figure 5-1

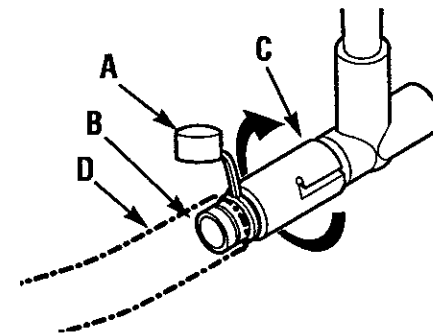

Figure 5-2: Oil drain.

## ENGINE CLEANING

• Stop engine, wait for parts to stop moving, disconnect spark plug wire, and allow engine to cool before inspecting or cleaning engine.

• Daily or more often, before running engine, remove grass and chaff from recoil finger guard or rotating screen to prevent engine damage caused by overheating. Also keep cooling vanes, governor linkage, springs and controls free of debris.

• Daily or more often, before running engine, clean muffler area (be sure muffler is cool) to remove all grass and combustible debris. If engine is equipped with a spark arrestor screen, remove assembly every 50 hours for cleaning and inspection. Replace if damaged.



# CUSTOMER RESPONSIBILITIES

## AIR CLEANER SERVICE

Improper air cleaner maintenance can cause engine damage.

### SERVICE SCHEDULE:

**Foam Filter (A, Fig. 5-3):** Wash and re-oil every 3 months or every 25 operating hours. Clean and re-oil daily if used in extremely dusty conditions.

**Paper or Foam/Screen Filters (B, Fig. 5-3):** DO NOT ATTEMPT TO CLEAN OR OIL FILTER. Replace once a year or every 100 operating hours, more often if used in extremely dusty conditions.

**DO NOT RUN ENGINE WITHOUT COMPLETE AIR CLEANER INSTALLED ON ENGINE.**

### A. To Service Foam Air Filter (A, Figure 5-3)

1. Wash in water and detergent solution and squeeze (don't twist) until all dirt is removed.
2. Rinse thoroughly in clear water.
3. Wrap in a clean cloth and squeeze (don't twist) until completely dry.
4. Saturate with engine oil and squeeze (don't twist) to distribute oil and remove excess oil.

### A. To Remove and Install Filters (Figure 5-3)

1. **Stop engine, wait for parts to stop moving, and disconnect spark plug wire.**
2. Remove wing nuts and cover.
3. Slide Filter (A) off Filter (B).
4. Inspect filter(s) for discoloration or dirt accumulation. If either is present, service as described in Service Schedule above.
5. Remove nuts and Filter (B). Discard Filter (B) and nuts (if service is necessary).
6. Clean inside of cover and body thoroughly.

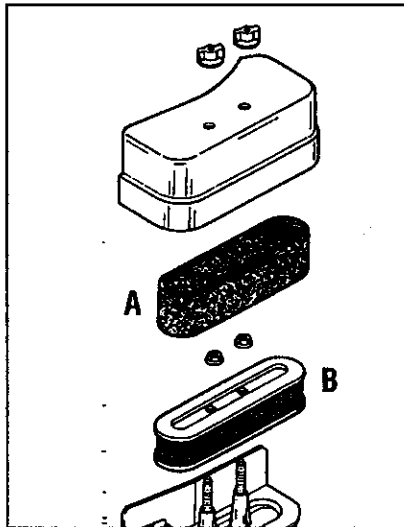

Figure 5-3

7. Install new Filter (B) and new nuts. Tighten nuts finger tight and then turn one (1) more complete turn.
8. Slide foam filter over paper filter.
9. Install cover and wing nuts. Tighten wing nuts.

## TIPPING MOWER FOR SERVICE

When servicing the underside of the mower for any reason, the mower should only be tipped backward on its rear wheels (and securely propped up to prevent it from falling). Tipping the mower forward or to either side could result in damage to engine.



### WARNING

Before servicing underside of mower, stop engine, wait for all parts to stop moving, and disconnect spark plug wire. Failure to follow this instruction could result in personal injury or property damage.

**TIP:** Before tipping mower, install a small plastic sandwich style bag under the gas cap and tighten securely. This will virtually eliminate any fuel weepage from the cap. *Be sure to remove the plastic bag before re-using mower.*

## CLEANING UNDERSIDE OF MOWER DECK

Frequently check, and clean if necessary, the underside of the mower deck. Grass build-up in this area can affect the cutting performance. Before inspecting or cleaning, make sure that the engine is shut off and the spark plug wire is disconnected from the spark plug.



### WARNING

Mower blades are sharp. When working near blades, wear heavy leather gloves or wrap blades in thick rags to protect yourself from the sharp edges.

## Inspection/Cleaning of Mower Deck

1. **Stop engine, wait for all parts to stop moving, and disconnect spark plug wire.**
2. Tip mower on rear wheels by following instructions "Tipping Mower For Service" on this page.
3. Use a plastic or metal scraper to remove grass build-up from deck or blades. If needed, spray with a garden hose.

# SERVICE AND ADJUSTMENTS

## SPARK PLUG

Inspect the spark plug (Figure 5-4) after every 100 hours of operation. Be sure the gap is set at .030". Do not reuse plug if it is severely worn or damaged.

Best results are obtained with a new plug. See engine owner's manual to determine proper replacement plug. Use of incorrect plug can cause engine damage.

NOTE: Do not clean spark plug in machines which use abrasive grit. Clean spark plug by scraping or wire brushing, or washing with a commercial solvent.

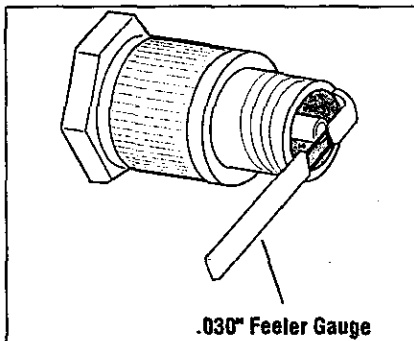

Figure 5-4: Spark plug.

## CARBURETOR

The carburetor is adjusted at the factory. It should not need to be reset. If black exhaust is noted, check the air cleaner first. An over-rich mixture is usually caused by a poorly serviced or clogged air cleaner element, not an improperly adjusted carburetor. If readjustment is necessary, contact your Sears Service Center.

## BELT COVER REMOVAL

The belt cover must be removed to perform several maintenance procedures.

### To Remove Belt Cover

1. Stop engine, wait for all parts to stop moving, and disconnect spark plug wire.
2. Remove four screws (R, Figure 5-5) and remove cover.

### To Reinstall Belt Cover

1. Position belt cover in place.
2. Secure with four screws removed earlier.

**WARNING**  
Do not operate unit without belt cover installed. Failure to follow this instruction could result in personal injury or property damage.

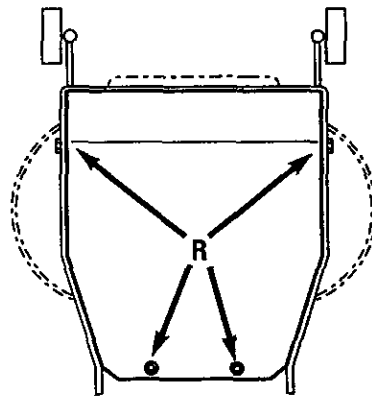

Figure 5-5: Belt cover removal.

## BLADE SPINDLE BELT REPLACEMENT

Follow this procedure to remove and replace the blade spindle drive belt (remove blade drive belt first; see "Blade Drive Belt Replacement").

1. Stop engine, wait for all parts to stop moving and disconnect spark plug wire.

2. Remove belt cover (see "Belt Cover Removal").

3. Align sight holes (O, Figure 5-6) in pulley with spindle housing-to-mower deck mounting bolts (L).

4. Loosen screw (J) and rotate arm (K) to the rear.

5. Loosen four mounting bolts (L) securing spindle housing (beneath mower deck) to mower deck.

6. Slide spindle housing (with pulley attached) toward center.

7. Replace belt (N) with new belt. **IMPORTANT:** Set blades perpendicular (90°) to each other.

8. Rotate arm (K) to move spindle housing and apply tension to belt. Belt cogs and pulley grooves must mesh together. When applying moderate finger tension (8-12 lbs.), belt should deflect approximately 1/2" (12.7 mm) at (P), midpoint of deck.

9. Tighten bolts (L) to 15 ft.-lbs. (20.3 Nm). Tighten screw (J).

10. Blades must not contact deck. Check and readjust as needed.

11. Reinstall blade drive belt and belt cover (removed earlier).

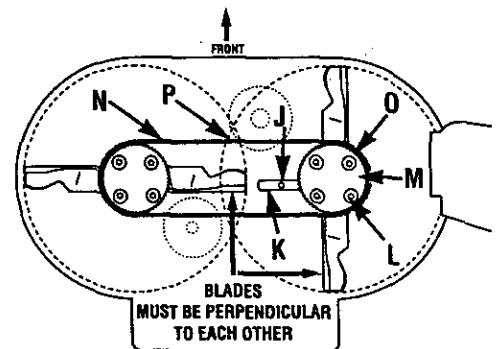

Figure 5-6: Blade Spindle Belt.

# SERVICE AND ADJUSTMENTS

## BLADE DRIVE BELT REPLACEMENT

Follow this procedure to remove and replace the blade drive belt. An assistant will be needed.

### To Remove Belt

1. Stop engine, wait for all parts to stop moving, and disconnect spark plug wire.
2. Disengage blade drive control (Figure 5-7) by releasing all controls on the mower.
3. Remove belt cover (see "Belt Cover Removal").
4. Loosen belt guides (B and C, Figure 5-8).
5. Move flap bracket (N, Figure 5-8) out of the way by loosening two screws (M).

6. Remove belt (A, Figure 5-8) from around sheaves.

### To Install Belt

1. Route belt (A, Figure 5-8) around sheaves as shown.
2. Have an assistant hold down Operator Presence Control and then push the Blade Drive Control forward until it latches in place (Figure 5-7).
3. With the Blade Drive Control lever engaged, adjust and tighten belt guide (B) to 1/32 - 1/16" away from tensioned belt. (Be sure that belt does not contact belt guide when belt is under tension.) Secure belt guide (C) rotated into position as shown in Figure 5-8.

4. Disengage Blade Drive Control.
5. Re-tighten two screws (M, Figure 5-8) that secure flap bracket (N).
6. Reinstall belt cover securely.

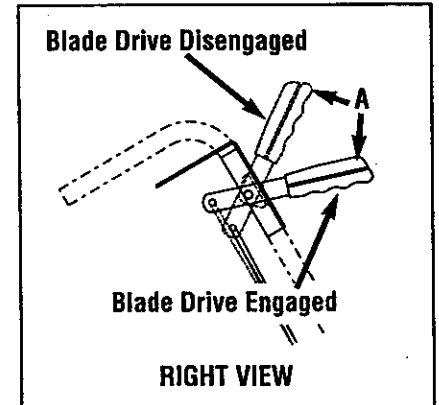

Figure 5-7: Blade Drive Control.

## BLADE BRAKE REPLACEMENT

Follow this procedure to install a new blade brake.

### To Remove Blade Brake

1. Stop engine, wait for all parts to stop moving, and disconnect spark plug wire.
2. Remove belt cover as described in "Belt Cover Removal" instructions.
3. Remove hardware (G, Figure 5-8) securing blade brake (H).
4. Remove old brake (H) from idler arm (I).

### To Install Brake

1. Position new brake (H) in place on idler arm (I).
2. Center brake in sheave groove and secure brake (H) with hardware (G) removed earlier.
3. Reinstall belt cover securely.
4. Test operation of blade brake (see "Blade Brake Control Test" on Page 22).

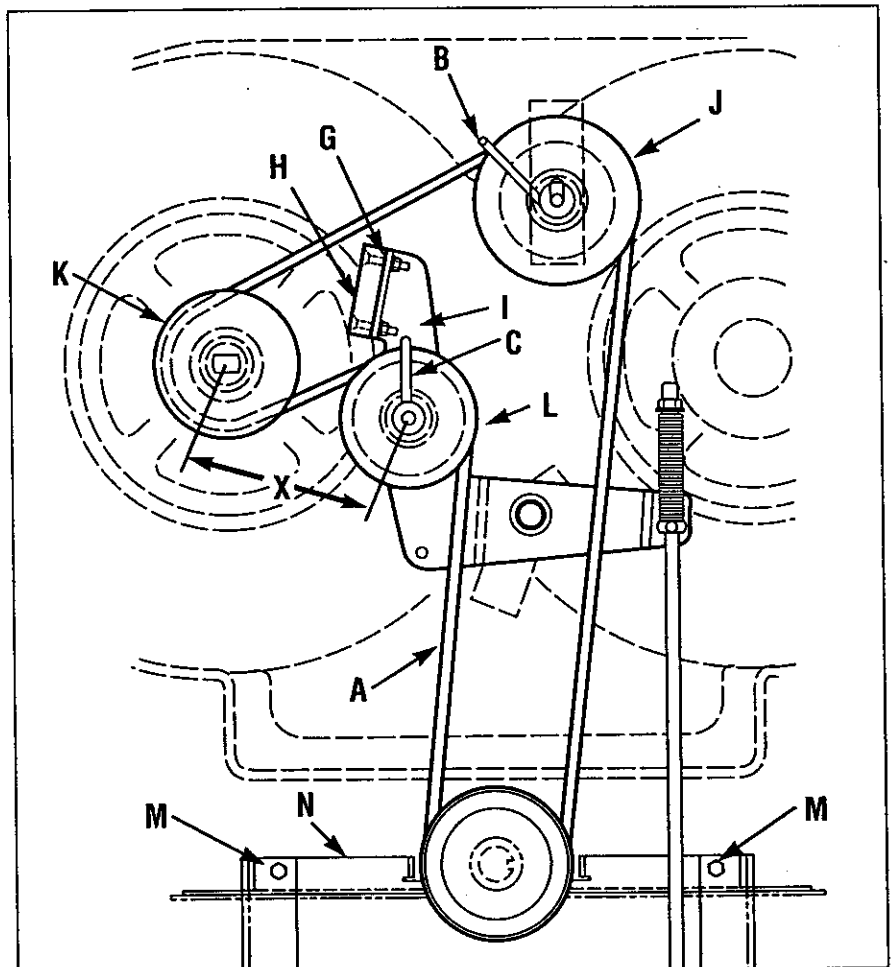

Figure 5-8: Blade drive.

# SERVICE AND ADJUSTMENTS

## BLADE DRIVE BELT ADJUSTMENT

If the blade drive belt is slipping due to lack of belt tension, follow the steps below.

1. **Stop engine, wait for all parts to stop moving, and disconnect spark plug wire.**

2. Remove belt cover as described in "Belt Cover Removal" instructions.

3. With mower on level ground, adjust blade cutting height at about 3" (measure from ground to flat portion of blade).

4. With the Blade Drive Control (Figure 5-7) in the disengaged position, set a gap of 1/8" between the spring (F, Figure 5-9) and flat washer (E) by adjusting the nut (D).

5. Reinstall the belt cover securely.

6. Test the operation of the blade brake (see "Blade Brake Control Test").

7. If the drive belt slips during operation, it may be necessary to relocate idler (J, Figure 5-9) in the slot provided in the mounting bracket. **With the engine stopped and the spark plug wire disconnected**, loosen the hardware on the idler (J) and slide it forward to take up slack in the belt.

8. Engage the blade drive and measure the distance (X, Figure 5-8) between the centers of pulleys (K) and (L). The distance should be 5-1/2 to 5-5/8". After obtaining the correct dimension, reinstall the belt cover securely and test the operation of the blade brake.

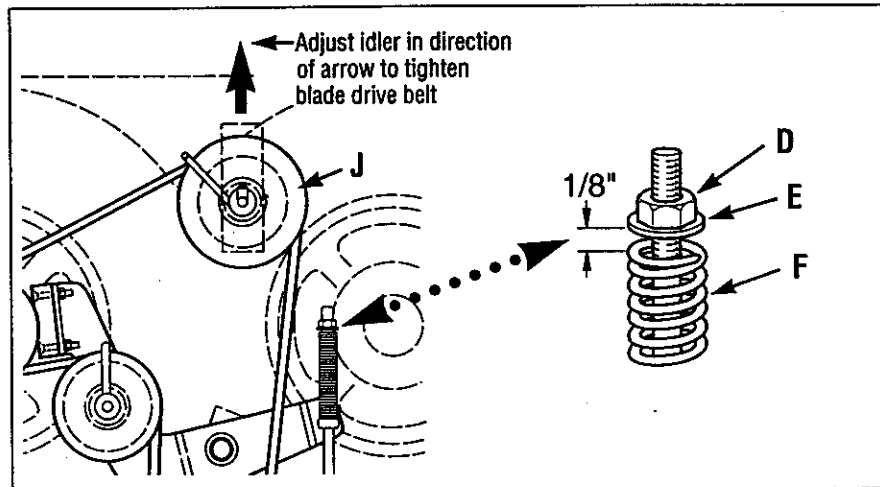

Figure 5-9: Blade drive adjustment.

# SERVICE AND ADJUSTMENTS

## BLADE DRIVE CONTROL LEVER ADJUSTMENT

Make the following adjustment if the Blade Drive Control Lever releases during operation.

1. **Stop engine, wait for all parts to stop moving, and disconnect spark plug wire.**

2. Engage the Operator Presence Control and the Blade Drive Control. Without releasing the controls, look inside the cutout at the rear of the frame and make sure the Operator Presence Control latches (A and B, Fig. 5-10) are fully engaged at point (C). If they are not fully engaged, improper operation or premature wear could result. To adjust, loosen hex nut (D) and shorten length of control rod (E). To avoid over-adjusting, turn rod only 1 to 2 turns per adjustment.

3. Tighten hex nut securely after adjusting control rod.

4. Test by releasing the Operator Presence Control. If properly adjusted, the Blade Drive Control will disengage when the Operator Presence Control is released. Re-adjust as necessary by repeating Steps 2 and 3.

## WHEEL DRIVE BELT REPLACEMENT

Follow this procedure to replace the wheel drive belt.

1. **Stop engine, wait for all parts to stop moving, and disconnect spark plug wire.**

2. Release all mower controls.

3. Remove belt cover as described in "Belt Cover Removal" instructions.

4. Locate wheel drive belt (O, Figure 5-11) and remove it from top sheave of engine sheave, backside idlers (P and Q) and transmission sheave (R).

5. Install new belt shown in Figure 5-11. Belt must be installed "inside out" "V" side of belt lies against engine sheave only. Flat side of belt lies against transmission sheave (R) and back-sided idlers (P and Q).

6. Make sure belt is inside belt guide (S, Figure 5-11).

7. Reinstall belt cover securely.

8. An adjustment to the drive belt may be necessary. See "Wheel Drive Belt Adjustment" on the next page.

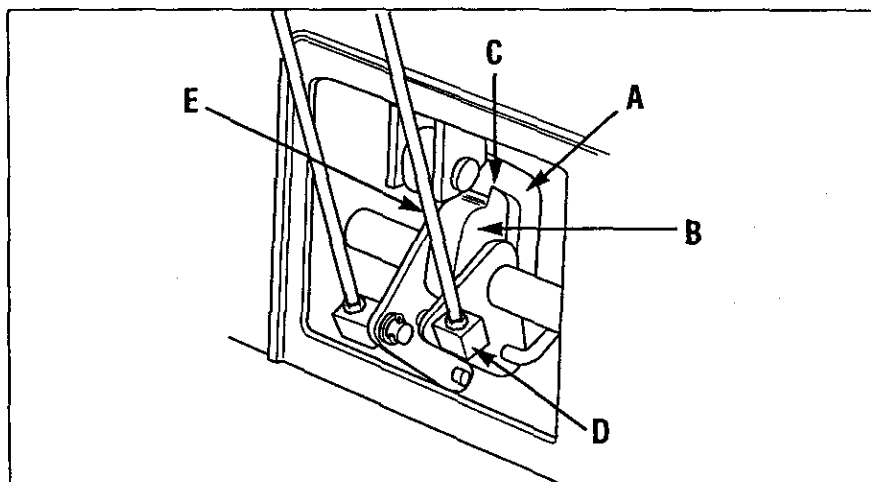

Figure 5-10: Blade Drive Control Lever adjustment.

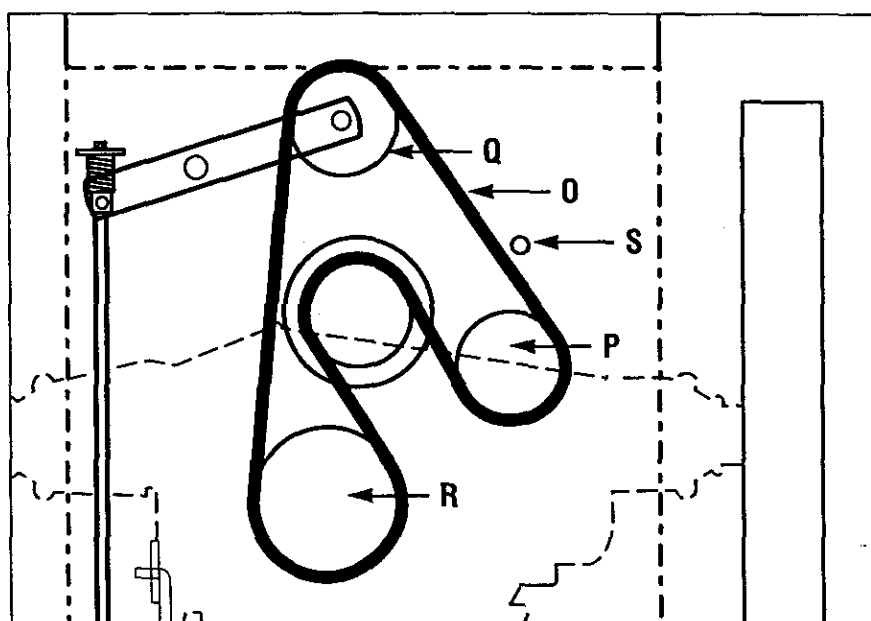

Figure 5-11: Wheel drive belt replacement.

# SERVICE AND ADJUSTMENTS

## WHEEL DRIVE BELT ADJUSTMENT

The wheel drive belt requires an adjustment if loss of drive belt tension (slippage) occurs. This is most noticeable when more traction is required (such as going up slopes).

### To Test Wheel Traction

1. Park machine on a paved (concrete, etc.) surface with front edge up against a sturdy wall, fence, etc.
2. Put Gear Select Lever in No. 1 setting.

**IMPORTANT:** Do not park against a painted or sided wall. Testing the wheel drive system requires machine to be forcibly pushed against wall. Damage to paint or siding could result.

3. With engine running, and machine placed firmly up against wall, hold down Operator Presence Control and fully engage wheel drive by squeezing Wheel Drive Control until it contacts handlebar.

4. Wheels should slip on paved surface. If they do not, an adjustment is required.

### To Adjust Wheel Drive Belt

1. **Stop engine, wait for all parts to stop moving, and disconnect spark plug wire.**

2. Remove cotter pin (A, Figure 5-12A) from upper end of Wheel Drive Control rod. Slide rod out of lever assembly.

3. Loosen jam nut (D, Figure 5-12).

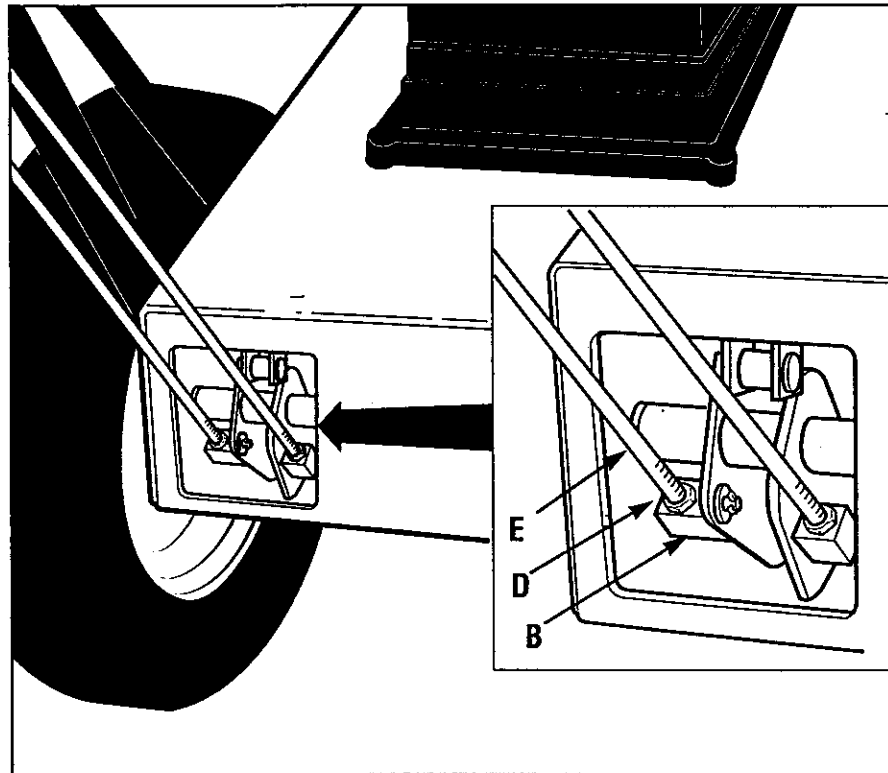

Figure 5-12: Wheel drive belt adjustment.

4. Thread rod (E, Figure 5-12) one or two turns clockwise for more tension or counterclockwise for less tension.

5. Insert rod back into hole in Wheel Drive Control lever and install cotter pin. Bend ends of cotter pin to secure.

6. Retest wheel traction. Repeat adjustment procedure, if necessary. Most comfortable operation will be obtained when the adjustment allows the lever to just make contact with the handgrip as sufficient wheel traction is achieved. When adjustment is complete, tighten jam nut (D) firmly against block (B).

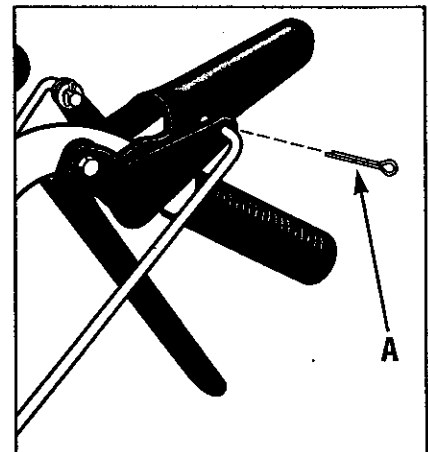

Figure 5-12A

# SERVICE AND ADJUSTMENTS

## WHEEL BRAKE ADJUSTMENT

This adjustment may be required if the machine does not hold on a hill with the Operator Presence Control disengaged, or if the brake drags with the Operator Presence Control engaged and the transmission in neutral.

1. **Stop engine, wait for all parts to stop moving, and disconnect spark plug wire.**
2. Disengage (release) the Operator Presence Control (M, Figure 5-13).
3. Slowly adjust at nut (O), if necessary, until the distance between the back of brake arm (N) and bracket (P) is  $3/8''-5/16''$ . Use small adjustments ( $1/4$  turn maximum). NOTE: It may be necessary to relieve spring tension when decreasing distance. To do so, have an assistant engage the Operator Presence Control while you adjust the nut.

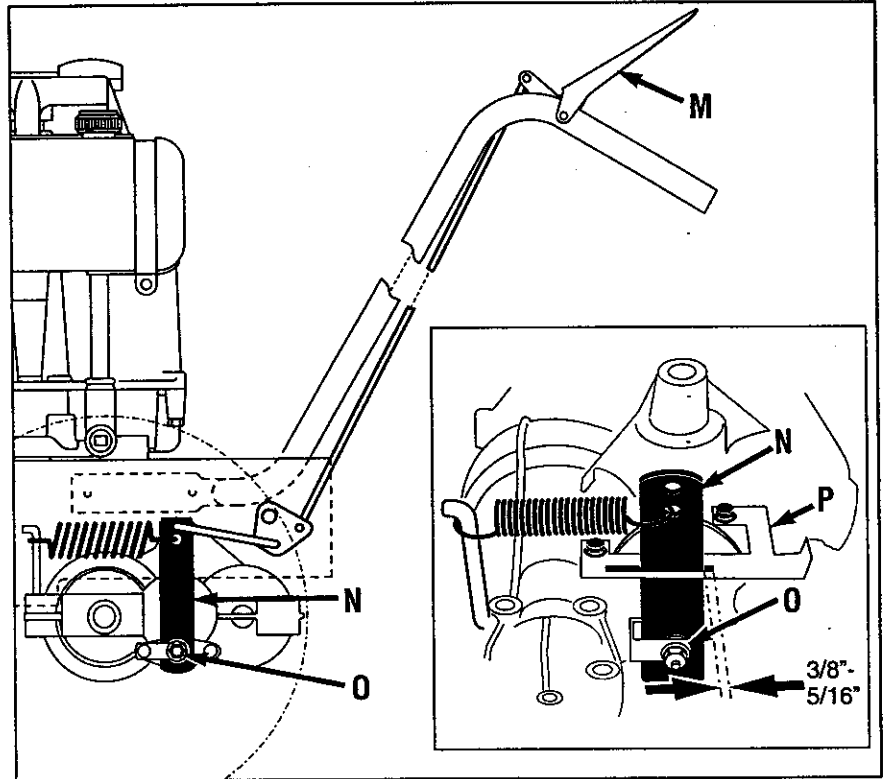

Figure 5-13: Wheel brake adjustment.

## TRANSMISSION NEUTRAL ADJUSTMENT

Follow this procedure to adjust neutral on the transmission.

1. **Stop engine, wait for all parts to stop moving, and disconnect spark plug wire.**
2. Rotate shift rod (I, Figures 5-14 and 5-15) clockwise until it stops in the neutral (N) position (from forward gear positions).
3. Hold down Operator Presence Control (M, Figure 5-13) and push unit forward and backward. Unit should move freely. If not, continue with Step 4.
4. Remove cotter pin securing shift link (P, Figure 5-15) to shift rod (I).
5. Move shift arm (X) back and forth as necessary into each detent until transmission is in neutral. NOTE: Moving shift arm (X) clockwise all the way to the left, and then one notch back counterclockwise, should put transmission

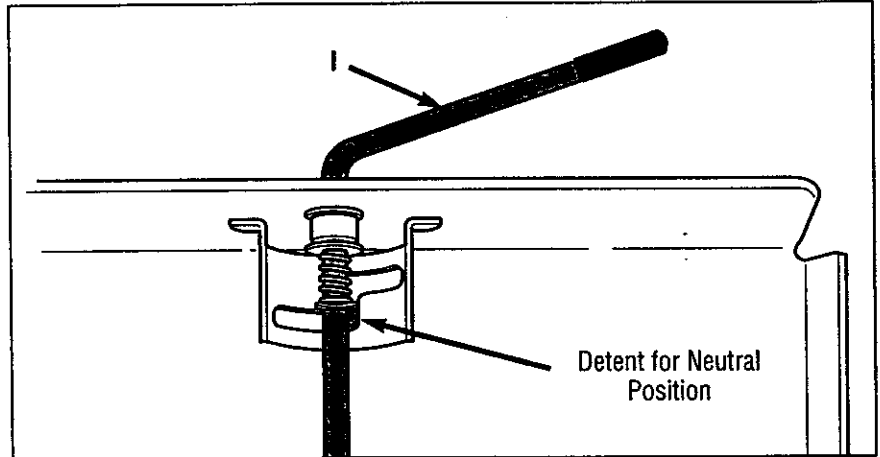

Figure 5-14: Gear Select Lever in neutral (N) position.

- into neutral. When transmission is in neutral, unit will move freely when pushed while holding the Operator Presence Control lever down. If transmission is NOT in neutral, there will be a slight drag on the wheels when pushing unit.
6. When shift arm (X) is in neutral position, rotate shift link (P) until hooked end fits back into hole in bottom end of shift rod (I).

NOTE: Shift rod (I) must be held in the neutral position (see Figure 5-14) while shift link (P) is adjusted.

7. Secure shift link (P) into shift rod (I) with cotter pin removed earlier.
8. Re-check neutral by pushing unit back and forth and shifting lever (I) from reverse to neutral. A small fine-tune adjustment may be required.

# SERVICE AND ADJUSTMENTS

## MOWER BLADES

Examine mower blades before operation. For efficient mowing, cutting edges of blades should always be kept sharp. Check for blade wear or damage. See Figure 5-16. Replace a severely worn or damaged blade with a new one.



### WARNING

Mower blades are sharp.

- When working near blades, wear heavy leather gloves or wrap blades in thick rags to protect yourself from the sharp edges.
- Wear eye protection when sharpening blades.

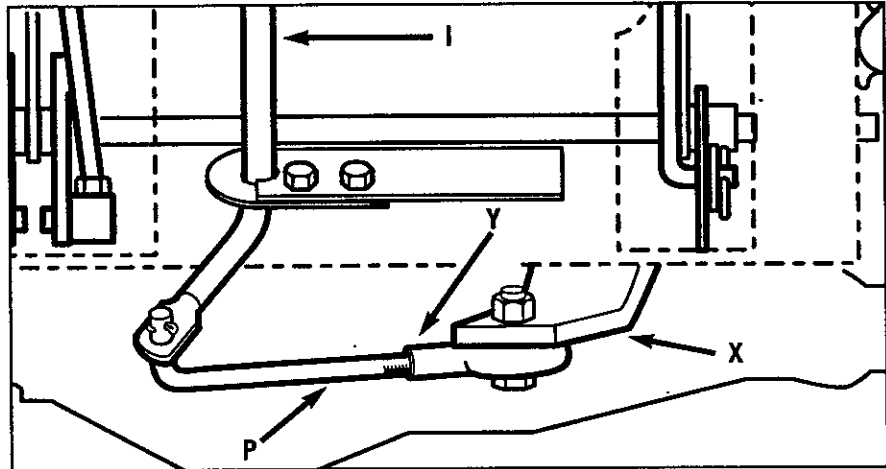

Figure 5-15: Transmission neutral (N) adjustment.

### To Inspect Blades

1. Stop engine, wait for all parts to stop moving, and disconnect spark plug wire.
2. Tip mower on rear wheels by following instructions "Tipping Mower For Service" in this Section of Manual.

### To Remove Blade

Remove bolt (Figure 5-18) and washer(s). Remove mower blade.

### Blade Sharpening

Grind or file the same amount from each blade end to maintain blade balance. An unbalanced mower blade produces excessive vibration and may damage spindle bearings. Sharpen cutting edge straight across, parallel to rear edge of mower blade. See Figure 5-16. After sharpening, blade balance must be checked.

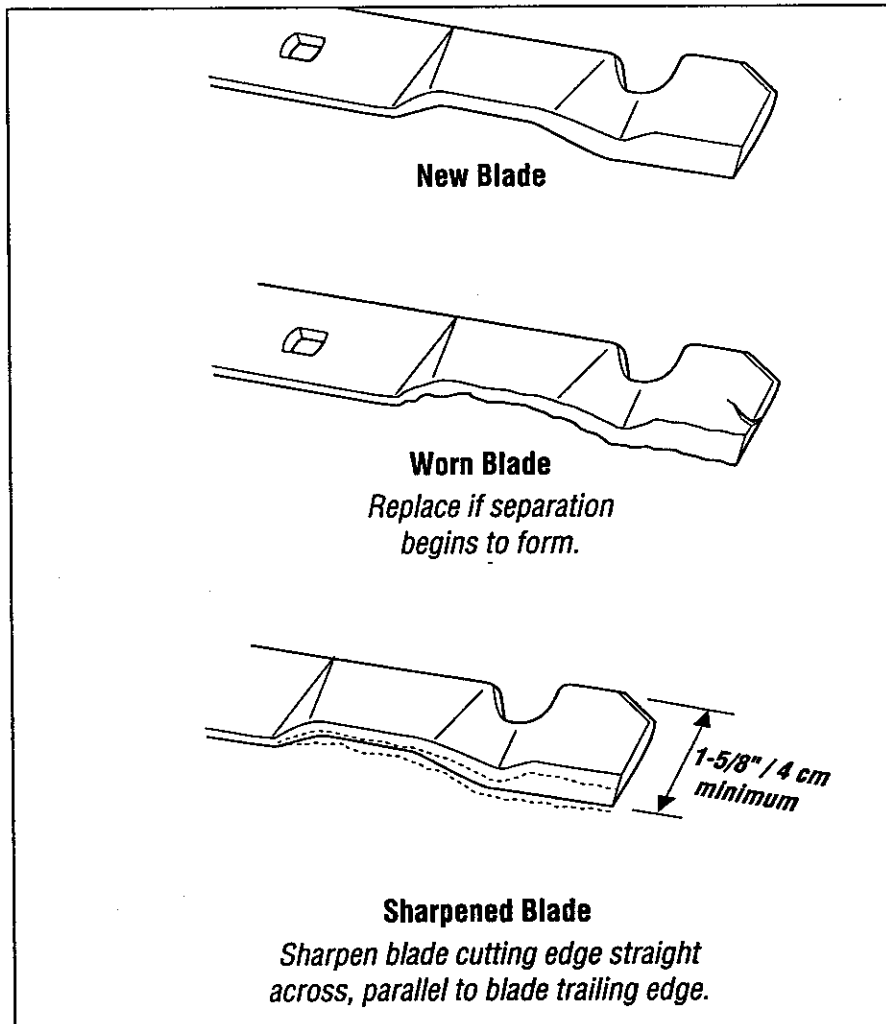

Figure 5-16: Blade Inspection.



# SERVICE AND ADJUSTMENTS

## Blade Installation

Blades must be installed perpendicular to each other (see Figure 5-17).

Install mower blade as shown in Figure 5-18 with flat side down. Install washer on bolt. Tighten bolts to a torque value of 35 ft. lbs. (47 Nm).

NOTE: If top bolt is removed, re-install using LOCTITE #242 thread sealant.

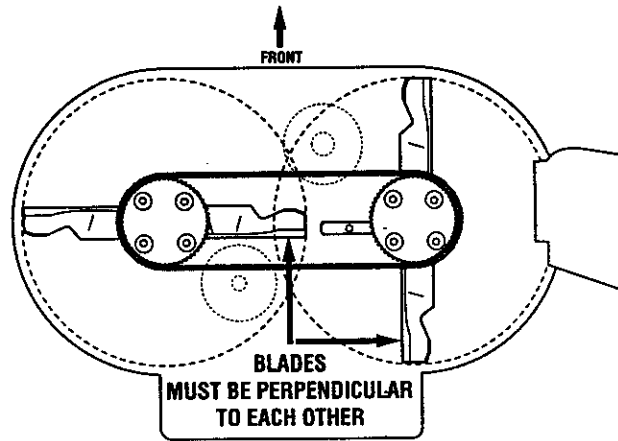

Figure 5-17

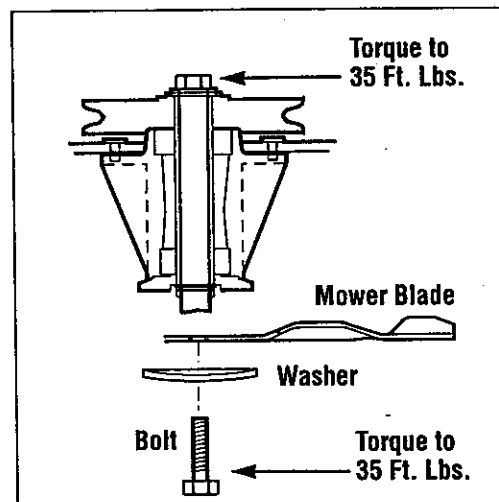

Figure 5-18: Blade spindle.

# STORAGE

## OFF-SEASON STORAGE

- *Stop engine, wait for all parts to stop moving, and disconnect spark plug wire before performing any storage procedures. Review the "Maintenance and Storage" safety rules in the Safety section of this Manual.*

## MOWER:

- Inspect all parts for damage, breakage, and wear. Tighten or replace fasteners. Contact your Sears Service Center for replacement parts.
- Lubricate as shown in the Customer Responsibilities section.
- Clean the exterior of the mower thoroughly and touch up all chipped or scratched surfaces to prevent rust from forming.

## ENGINE:

**IMPORTANT:** IT IS IMPORTANT TO PREVENT GUM DEPOSITS FROM FORMING IN ESSENTIAL FUEL SYSTEM PARTS SUCH AS CARBURETOR, FUEL FILTER, FUEL HOSE OR TANK DURING STORAGE. ALSO, EXPERIENCE INDICATES THAT ALCOHOL BLENDED FUELS (CALLED GASOHOL OR USING ETHANOL OR METHANOL) CAN ATTRACT MOISTURE WHICH LEADS TO SEPARATION AND FORMATION OF ACIDS DURING STORAGE. ACIDIC GAS CAN DAMAGE THE FUEL SYSTEM OF AN ENGINE WHILE IN STORAGE.

- Drain the fuel tank.
- Start the engine and let it run until the fuel lines and carburetor are empty.
- Never use engine or carburetor cleaner products in the fuel tank or permanent damage may occur.
- Use fresh fuel next season.

## WARNING

Never store machine with fuel in the fuel tank inside a building where fumes may reach an open flame or spark, or where ignition sources are present such as hot water and space heaters, furnaces, clothes dryers, stoves, electric motors, etc.

**NOTE:** Fuel stabilizer is an acceptable alternative in minimizing the formation of fuel gum deposits during storage. Add stabilizer to gasoline in fuel tank or storage container. Always follow the mix ratio found on stabilizer container. Run engine at least 10 minutes after adding stabilizer to allow the stabilizer to reach the carburetor. Do not drain the gas tank and carburetor if using fuel stabilizer.

## ENGINE OIL:

Drain oil (with engine warm) and replace with clean engine oil. See "ENGINE" in the Customer Responsibilities Section of this manual.

## CYLINDER:

- Remove spark plug.
- Pour one ounce of oil through spark plug hole into cylinder.
- Pull starter handle slowly a few times to distribute oil.
- Replace with new spark plug.

## OTHER:

- Do not store gasoline from one season to another.
- Replace your gasoline can if your can starts to rust. Rust and/or dirt in your gasoline will cause problems.
- Cover your unit with a suitable protective cover that does not retain moisture. Do not use plastic. Plastic cannot breathe which allows condensation to form and will cause your unit to rust.

**IMPORTANT:** NEVER COVER MOWER WHILE ENGINE AND EXHAUST AREAS ARE STILL WARM.

# TROUBLESHOOTING



## WARNING

Before inspecting, cleaning or servicing the machine, shut off engine, make sure that all moving parts have come to a complete stop, and disconnect spark plug wire.

Failure to follow this instruction could result in personal injury or property damage.

## Troubleshooting Chart

Possible cause	Symptom															
	Engine does not turn over.	Engine turns over but will not start.	Engine starts only after repeated tries.	Engine runs roughly.	Engine stalls in a few seconds.	Engine runs but unit does not move.	Wheel drive always engaged.	Engine stalls when hot.	Engine overheats.	Engine does not shut off.	Blade drive inoperative.	Blade drive always engaged.	Battery not charging (if applicable).	Poor mowing performance.	Blade does not stop when Operator Presence Control is released.	Excessive vibration.
Engine malfunction.	•	•	•	•	•			•	•	•						•
Improperly adjusted drive linkage.						•	•				•	•		•	•	•
Dirty engine cooling fins or flywheel screen.								•								
Faulty ignition.	•	•	•	•	•			•	•							
Faulty spark plug.	•	•	•	•				•								
Empty fuel tank.	•	•			•			•								
Battery or charging malfunction (if applicable).	•	•							•			•				
Improperly adjusted or dirty carburetor.		•	•	•	•				•							
Improper oil level.									•							•
Dirty air cleaner element.		•		•	•				•							
Improperly adjusted choke (if applicable).		•	•	•	•				•							
Transmission malfunction.						•	•									
Improperly adjusted drive linkage.						•	•				•	•				•
Broken, loose or worn belt(s).				•	•	•					•	•		•		
Dull blade(s).														•		•
Throttle control out of adjustment.		•	•						•							
Blade/brake system out of adjustment.											•	•			•	
Blade(s) out of balance.														•		•
Loose hardware.											•	•				•

# OPERATING AND SAFETY DECALS

## SAFETY DECALS

Make certain all safety decals on this equipment are kept clean and in good condition. The decals are shown (at reduced sizes) below. If you need a replacement decal, please refer to the Repair Parts section of this manual.

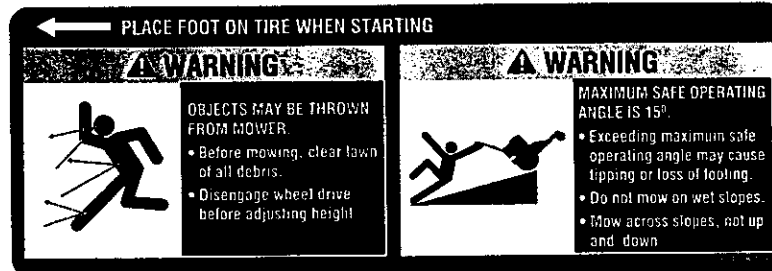

On top, rear of engine platform

### CAUTION

#### PINCH POINTS.

Do not operate without all belt guards in place.



Beneath belt/pulley cover



On left side of mower deck

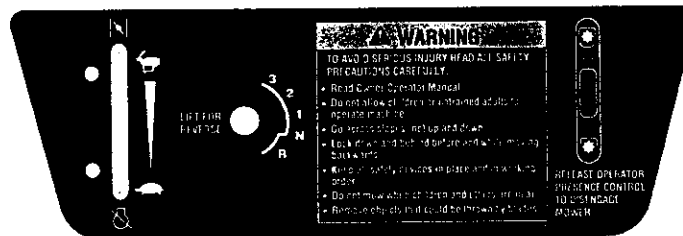

On Control Panel

# CRAFTSMAN 8HP MODEL 987.889000 REPAIR PARTS

## HANDLEBAR AND CONSOLE ASSEMBLY

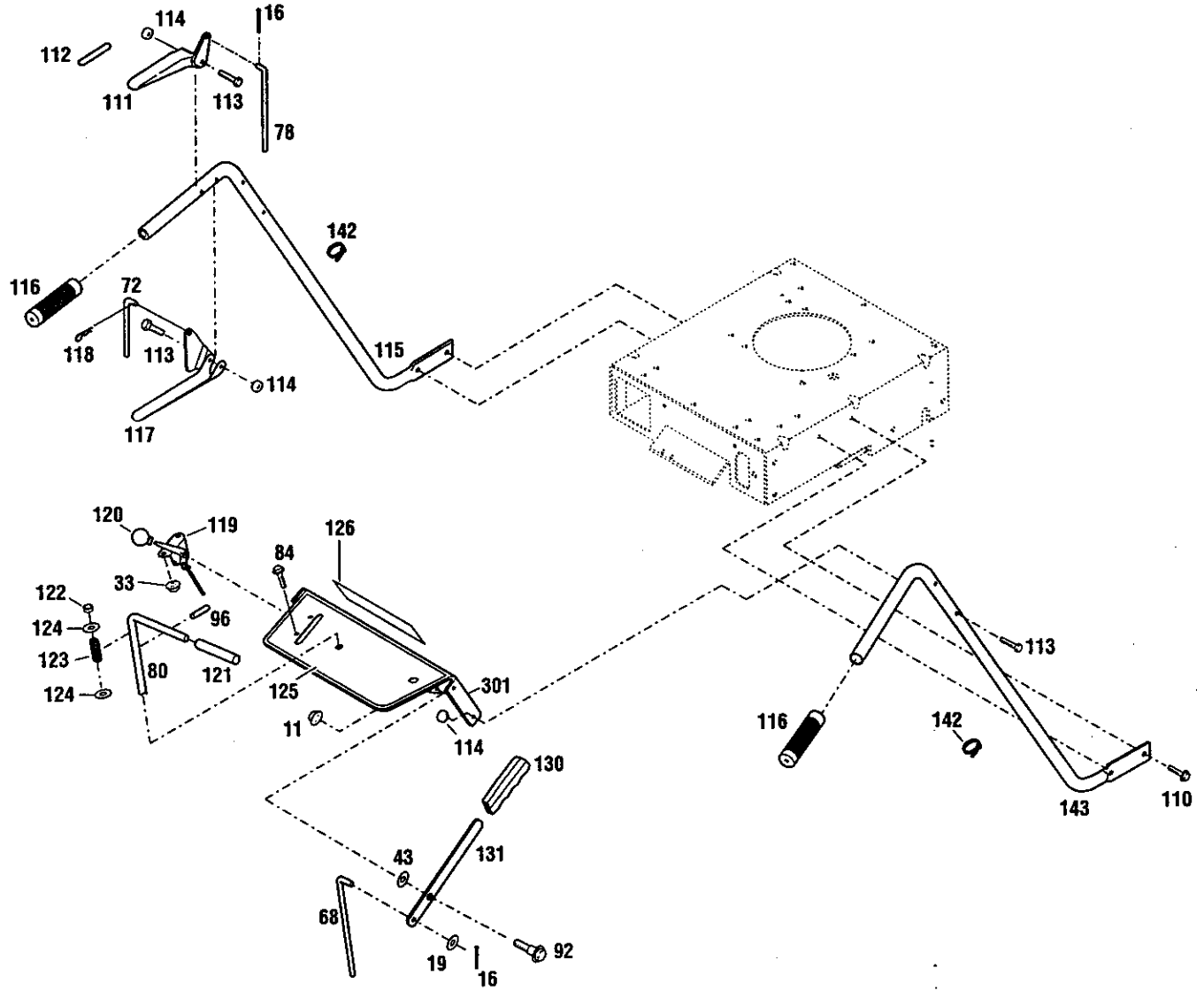

Ref.	Part	Description	Qty.	Ref.	Part	Description	Qty.
11	1186393	Flange Locknut, 3/8-16.....	1	116	1703539	Handle Grip .....	2
16	1185147	Cotter Pin, 3/32 x 5/8 .....	2	117	1773605001	Control Handle .....	1
17	1721252	J-Clip.....	1	118	1717897	Hair Pin, 5/64 .....	1
19	1107382	Flat Washer, 5/16.....	4	119	1915927	Throttle Control .....	1
33	1186389	Flange Locknut, 1/4-20.....	2	120	1737118	Knob.....	1
43	1702646	Flat Washer, 1/2.....	1	121	1737041	Handle Grip .....	1
68	1769888	Upper Blade Rod .....	1	122	1715716	Nylon Bushing.....	1
72	1773607	Upper Transmission Rod.....	1	123	1721492	Compression Spring.....	1
78	1769872	Upper Brake Rod.....	1	124	1107385	Flat Washer, 1/2.....	1
80	1769874	Shift Rod.....	1	125	1768633	Warning Decal .....	1
84	1186308	Flange Lock Screw, 1/4-20 x 1/2 .....	2	126	1915931	Logo Decal .....	1
92	1703051	Shoulder Bolt .....	1	130	1764984	Handle Grip .....	1
96	1185279	Roll Pin, 1/4 x 2-1/4 .....	1	131	1768223	Mower Engage Lever.....	1
110	1186329	Flange Lock Screw, 5/16 x 3/4 .....	4	142	1735531	Plastic Tie.....	5
111	1770445001	Control Handle .....	1	143	1764923001	Right Handlebar .....	1
112	1768452	Operator Presence Control Decal .....	1	172	1724491	Screw, 5/16-18 x 3/4" .....	1
113	1915793	Screw, 1/4-20 x 1-3/4 - Grade 8 .....	5	301	1915935	Console Assembly (Incl. Ref. 125) .....	1
114	1734398	Locknut, 1/4-20.....	6				
115	1764922001	Left Handlebar.....	1				

# CRAFTSMAN 8HP MODEL 987.889000 REPAIR PARTS

## DRIVE ASSEMBLY

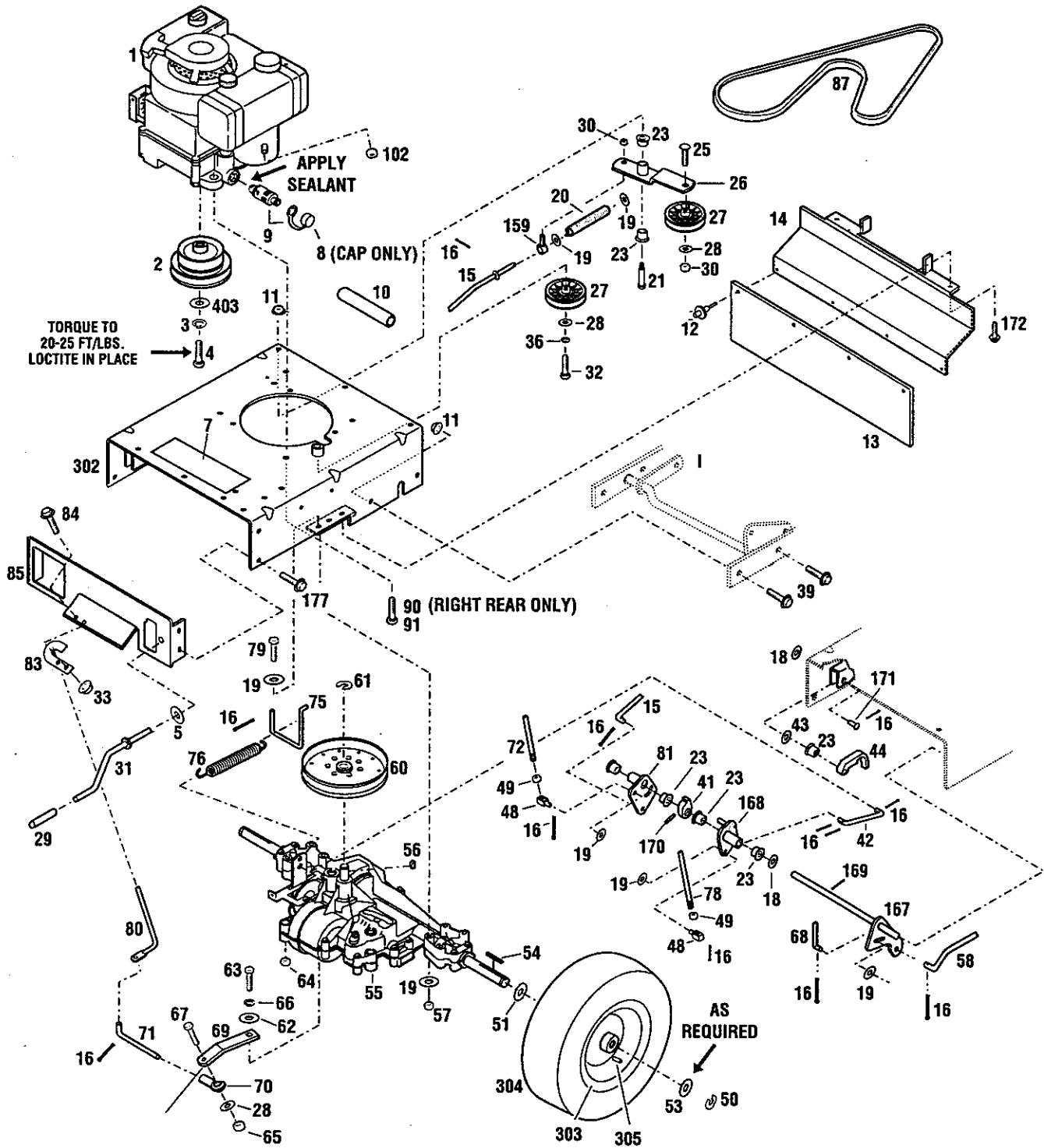

# CRAFTSMAN 8HP MODEL 987.889000 REPAIR PARTS

## DRIVE ASSEMBLY

Ref.	Part	Description	Qty.	Ref.	Part	Description	Qty.
1	*	Engine, 8 HP .....	1	58	1770247	Lower Blade Rod .....	1
2	1769904	Engine Pulley .....	1	60	1770326	Transaxle Pulley .....	1
3	1100243	Lock Washer, 3/8.....	1	61	1118808	Retaining Ring.....	1
4	1915933	Bolt, 3/8-24 x 1-3/4 - Grade 8 .....	1	62	1107381	Flat Washer, 1/4.....	3
5	1773599	Washer, Nylon.....	1	63	1100002	Screw, 1/4-28 x 3/4.....	1
7	1915475	Warning Decal .....	1	64	1186391	Flange Locknut, 5/16-18.....	1
8	1766326	Oil Valve Cap .....	1	65	1110108	Locknut, 3/8-16.....	1
9	1768865	Oil Valve (Incl. Ref. 8) .....	1	66	1100241	Lock Washer, 1/4.....	1
10	1909371	Oil Drain Hose .....	1	67	1100043	Screw, 3/8 x 1-1/4.....	1
11	1186393	Flange Locknut, 3/8-16.....	5	68	1769888	Upper Blade Rod .....	1
12	1727379	Pop Rivet, 3/16 .....	4	69	1768140	Transmission Arm .....	1
13	1769870	Flap .....	1	70	1767837	Ball Joint .....	1
14	1769869001	Flap Bracket.....	1	71	1768628	Shift Link Rod.....	1
15	1769885	Lower Transmission Rod.....	1	72	1769873	Upper Transmission Rod.....	1
16	1185147	Cotter Pin, 3/32 x 5/8.....	8	75	1768624	Spring Attachment Rod.....	1
18	1890234	Flat Washer, 1/2.....	1	76	1768636	Extension Spring .....	1
19	1107382	Flat Washer, 5/16.....	5	78	1769872	Upper Brake Rod .....	1
20	1711864	Compression Spring.....	1	79	1111609	Screw, 5/16-18 x 2-3/4.....	2
21	1763219	Shoulder Bolt .....	1	80	1769874	Shift Rod .....	1
23	1715538	Nyliner, 1/2.....	2	81	1769875	Clutch Arm Pivot .....	1
25	1748393	Carriage Bolt, 3/8-16 x 1-3/4.....	1	83	1768630001	Shift Rod Bracket .....	1
26	1764920	Idler Arm .....	1	84	1186308	Flange Lock Screw, 1/4-20 x 1/2 .....	2
27	1756151	Idler Pulley .....	2	85	1769852023	Backplate .....	1
28	1107383	Flat Washer, 3/8.....	3	87	1770334	V-Belt .....	1
29	1715685	Plastic Grip.....	1	90	1768194	Thread Forming Screw, 3/8-16 x 1-1/2..	1
30	1733398	Top Locknut, 3/8-16 .....	1	91	1762042	Thread Forming Screw, 3/8-16 x 1 .....	3
31	1915831	Lift Crank Assembly .....	1	102	1186229	Hex Nut, 1/4-20 .....	1
32	1100086	Bolt, 3/8-16 x 1-3/4.....	1	159	1769038	Eye Bolt.....	2
33	1186389	Flange Locknut, 1/4-20.....	4	167	1769882	Pivot Shaft Assembly .....	1
36	1100243	Lock Washer, 3/8.....	1	169	1100350	Cotter Pin .....	3
39	1186347	Flange Lock Screw, 3/8-16 x 1 .....	4	168	1769878	Brake Arm .....	1
41	1769881	Interlock Cam .....	1	170	1187961	Drive Pin, 5/32 x 1.....	1
42	1769877	Lower Brake Rod.....	1	171	1730851	Clevis Pin, 1/2 x 1-1/4 .....	1
43	1702646	Washer, Flat 1/2.....	3	172	1724491	Screw, 5/16-18 x 3/4.....	2
44	1770361	Interlock Latch .....	1	177	1740496	Flange Screw, 5/16-18 x 3/4.....	2
48	1725264	Swivel Block.....	2	302	1915936	Frame Weldment Ass'y (Incl. Ref. 7) .....	1
49	1186258	Jam Nut, 5/16-18 .....	2	303	1768180	Wheel Rim .....	2
50	1185388	Retaining Ring.....	2	304	1756444	Tire .....	2
51	1708012	Flat Washer .....	4	305	1718086	Valve Stem .....	2
53	1701447	Special Washer .....	A/R	400	97092	Loctite 242, 0.02 oz. Tube .....	N/I
54	1769781	Square Key, 3/16 x 2-1/2.....	2	403	1768818	Washer-flat.....	1
55	*	Transmission Assembly (Model 915-029)	1	---	1905122	Owner's Manual.....	1
56	1104436	Woodruff Key, 3/16 x 3/4 .....	1				
57	1732499	Top Locknut, 5/16-18 .....	4				

- \* See parts breakdown in this Section.
- A/R As required.
- N/I Item not included with unit; order separately.

# CRAFTSMAN 8HP MODEL 987.889000 REPAIR PARTS

## FRONT FRAME ASSEMBLY

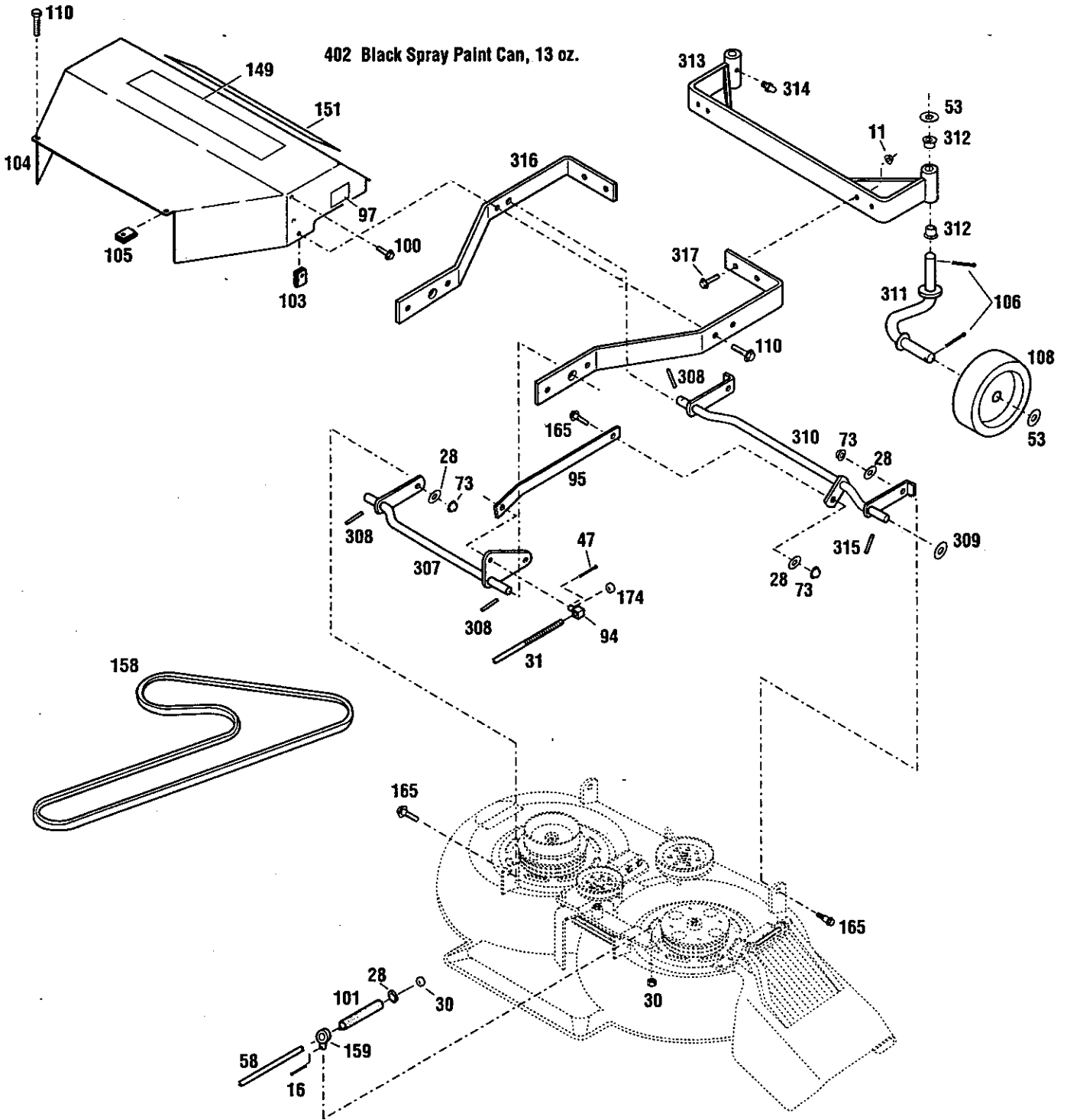



# CRAFTSMAN 8HP MODEL 987.889000 REPAIR PARTS

## FRONT FRAME ASSEMBLY

Ref.	Part	Description	Qty.	Ref.	Part	Description	Qty.
11	1186393	Flange Locknut, 3/8-16.....	9	110	1186329	Flange Lock Screw, 5/16 x 3/4 .....	2
16	1185147	Cotter Pin, 3/32 x 5/8 .....	2	149	1915930	Logo Decal .....	1
28	1107383	Flat Washer, 3/8.....	6	151	1915937	33" Combination Deck Decal .....	1
30	1733398	Locknut, 3/8-16.....	2	158	1769767	V-Belt .....	1
31	1769895	Lift Crank.....	1	159	1769038	Eye Bolt.....	1
47	1100349	Cotter Pin.....	1	165	1754125	Shoulder Bolt .....	5
53	1701447	Special Washer.....	4	174	1770355	Toplock Nut .....	1
58	1770247	Lower Blade Rod.....	1	307	1769903001	Rear Lift Assembly .....	1
73	1185506	Flange Locknut, 3/8-16.....	5	308	1185469	Roll Pin, 1/4 x 1.....	2
94	1768231	Pivot Block .....	1	309	1107386	Flat Washer, 5/8.....	1
95	1769521001	Leveler Bar .....	1	310	1770248001	Front Lift Assembly .....	1
97	1769889	Cutting Height Decal .....	1	311	1768477001	Spindle Assembly.....	2
100	1769344	Tap Screw, #8 x 3/8.....	8	312	1764140	Flange Bearing.....	4
101	1769007	Compression Spring.....	1	313	1769743001	Gage Support .....	1
103	1185498	Speed Nut, 5/16-18 .....	2	314	1185976	Grease Fitting .....	2
104	1764996023	Belt Guard .....	1	315	1185759	Drive Pin, 1/4 x 3.....	2
105	1185873	Speed Nut, 5/16-18 .....	2	316	1769899001	Mower Support .....	2
106	1100352	Cotter Pin .....	4	317	1186347	Whizlock Screw, 3/8-16 x 1.....	4
108	1743891	Gage Wheel .....	2	402	1735222	Black Spray Paint Can, 13 Oz. ....	N/I

N/I Item not included with unit; order separately.

# CRAFTSMAN 8HP MODEL 987.889000 REPAIR PARTS

## MOWER DECK ASSEMBLY

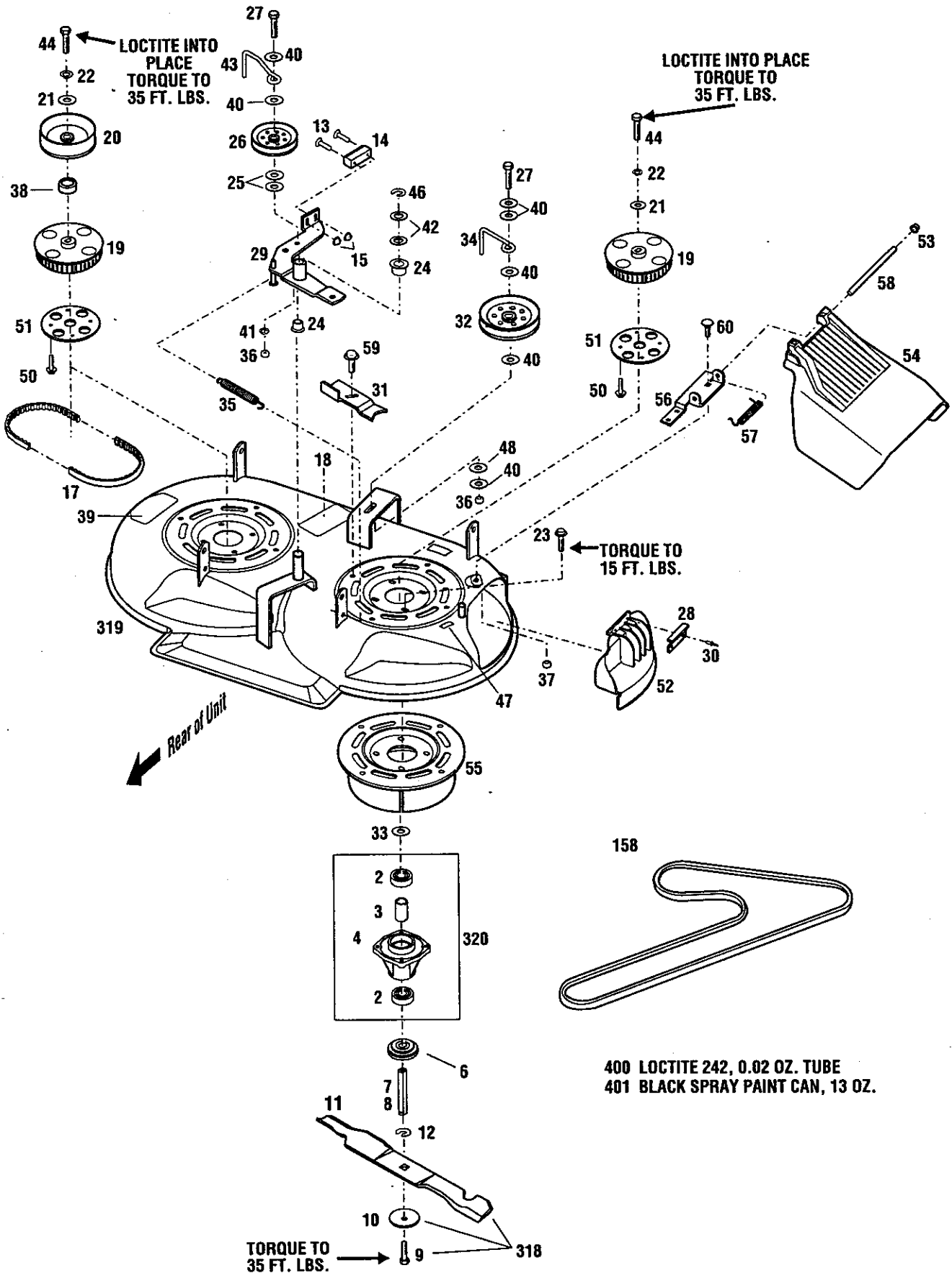

# CRAFTSMAN 8HP MODEL 987.889000 REPAIR PARTS

## MOWER DECK ASSEMBLY

Ref.	Part	Description	Qty.	Ref.	Part	Description	Qty.
2	1185574	Ball Bearing .....	4	40	1768818	Flat Washer, 3/8 x 3/4.....	7
3	1746869	Spacer .....	2	41	1100243	Lock Washer, 3/8.....	1
4	1915280	Mower Spindle .....	2	42	1701447	Flat Washer .....	2
6	1765029	Blade Spacer .....	2	43	1764135	Belt Guide.....	1
7	1766061	Right Spindle Shaft .....	1	44	1769397	Screw, 7/16-14 x 1-1/4.....	2
8	1768169	Left Spindle Shaft (long) .....	1	46	1113527	Retaining Ring.....	1
9	1765196	Screw, 7/16-14 x 1 .....	2	47	1768451	Warning Decal.....	1
10	1765197	Belleville Washer .....	2	48	1185715	Pyramid Washer, 3/8 .....	1
11	1910917	Blade, 33" Mulching.....	2	50	1771925	Triplask Screw, 1/4-20 x 5/8.....	8
12	1185649	Retaining Ring .....	2	51	1771922001	Sprocket Plate .....	2
13	1771081	Flat Head Screw, #10-24 x 1-1/4 .....	2	52	1773642	Mulcher Cover, Fold-Up Style (Incl. Ref. 28 and 30) .....	1
14	1771083	Brake Pad .....	1	53	1727342	Cap .....	2
15	1185985	Nylon Locknut, #10-24 .....	2	54	1910931	Discharge Chute .....	1
17	1773600	Toothed Drive Belt .....	1	55	19f0948001	Weldment Doubler .....	2
18	1768435	Caution Decal .....	1	56	1910951001	Bracket, Chute Hinge .....	1
19	1774220	Cogged Pulley, 56T .....	2	57	1910971	Spring, Discharge Chute.....	1
20	1769362	Drive Pulley .....	1	58	1910972	Pin, Discharge Chute .....	1
21	1736484	Flat Washer, 7/16.....	2	59	1740496	Screw, Thread-Forming.....	8
22	1100244	Lock Washer, 7/16.....	2	60	1186098	Bolt, Carriage, 3/8-18 x 3/4 .....	1
23	1773523	Flange Lock Screw, 5/16-18 x 1 .....	8	158	1769767	V-Belt .....	1
24	1764140	Flange Bushing.....	2	318	1773595	Mulching Blade Kit (Incl. Refs. 9, 10 and 11).....	1
25	1701055	Flat Washer .....	2	319	1773587	Mower Deck Assembly (Incl. Refs. 18, 39 & 47).....	1
26	1762794	Idler Pulley .....	1	320	1769048	Mower Spindle Assembly (Incl. Refs. 2, 3, 4 & 5).....	2
27	1100062	Hex Head Capscrew, 3/8-16 x 2-1/2 .....	2	400	97092	Loctite 242, 0.02 oz. Tube .....	N/I
28	1911054	Adapter Trim.....	1	401	1735222	Black Spray Paint Can, 13 oz. ....	N/I
29	1770803	Idler Arm .....	1				
30	1186059	Pop Rivet .....	2				
31	1911021001	Belt Tension Adjustment Bracket .....	1				
32	1749911	Idler Pulley .....	1				
33	1766787	Special Thrust Washer .....	2				
34	1720717	Belt Guide.....	1				
35	1756595	Extension Spring .....	1				
36	1186231	Nut, 3/8-16.....	2				
37	1732499	Locknut, 5/16-18.....	1				
38	1723996	Pulley Spacer .....	1				
39	1739687	Danger Decal.....	1				

N/I Item not included with unit; order separately.

# CRAFTSMAN 8HP MODEL 987.889000 REPAIR PARTS

## Transaxle Assembly

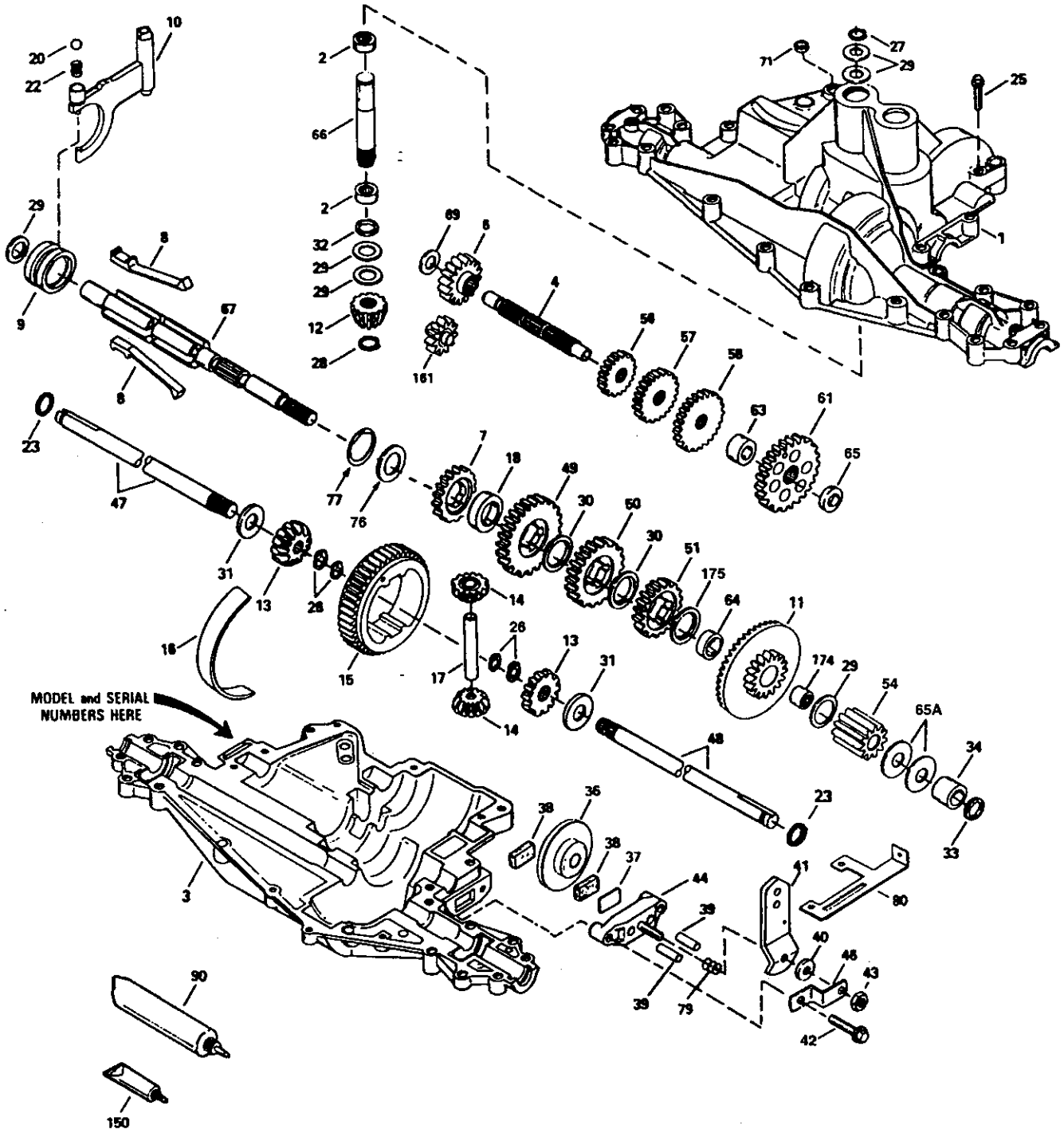

# CRAFTSMAN 8HP MODEL 987.889000 REPAIR PARTS

## TRANSAXLE ASSEMBLY

Ref.	Part	Description	Qty.	Ref.	Part	Description	Qty.
1	772113	Transaxle Cover.....	1	40	792076A	Washer .....	1
2	780086	Needle Bearing .....	2	41	790045	Brake Lever .....	1
3	770110	Transaxle Case .....	1	42	792073	Screw, 1/4-20 x 1-1/4" .....	2
4	776300	Countershaft .....	1	43	792075	Locknut, 5/16-24 .....	1
6	778281	Spur Gear (16 teeth) .....	1	44	790025	Brake Pad Holder .....	1
7	778122A	Spur Gear (22 teeth) .....	1	46	786086	Brake Lever Bracket .....	1
8	792160	Shift Key .....	4	47	774747	Axle (16-1/4" long) .....	1
9	784373	Shift Collar .....	1	48	774888	Axle (11" long) .....	1
10	784365	Shift Rod & Fork .....	1	49	778123A	Spur Gear (25 teeth) .....	1
11	778261	Bevel Gear & Bearing (Incl. 174) .....	1	50	778122A	Spur Gear (22 teeth) .....	1
12	778262	Bevel Pinion (14 teeth).....	1	51	778273	Spur Gear (19 teeth) .....	1
13	778221	Bevel Gear (16 teeth) .....	2	54	778263	Spur Gear (11 teeth) .....	1
14	778068	Differential Pinion .....	2	56	778127A	Spur Gear (25 teeth) .....	1
15	778260	Ring Gear .....	1	57	778128A	Spur Gear (28 teeth) .....	1
16	786150	Bearing Strip .....	1	58	778129A	Spur Gear (30 teeth) .....	1
17	786139	Drive Pin .....	1	61	778265	Spur Gear (34 teeth) .....	1
18	786147	Neutral Spacer .....	1	63	786158	Spacer.....	1
20	792077	Ball, 5/16" dia. ....	1	64	786072	Output Shaft Spacer.....	1
22	792079	Spring .....	1	65	780162	Washer .....	1
23	788061	Seal Ring .....	2	65A	780160	Washer .....	2
25	792073	Screw, 1/4-20 x 1-1/4" .....	17	66	776299	Input Shaft .....	1
26	792125	Retaining Ring .....	4	67	776352	Shifter & Brake Shaft .....	1
27	792035	Retaining Ring .....	1	69	780161	Washer .....	1
28	788040	Retaining Ring .....	1	71	788069	Square Cut Ring .....	1
29	780072	Washer .....	6	76	780090	Washer .....	1
30	780108	Washer .....	2	77	788078A	Inverted Retaining Ring (pkg. of 2) .	1
31	780001	Washer .....	2	79	792144	Spring .....	1
32	792001	"O" Ring .....	1	80	790063A	Brake Bracket .....	1
33	788076	"O" Ring .....	1	90	788067B	Grease Specification .....	1
34	780159	Bushing .....	1	150	510334	Gasket Eliminator (Loctite #515) .....	1
36	790071	Brake Disk .....	1	161	776302	Reverse Idler .....	1
37	790007	Brake Pad Plate .....	1	174	780085	Needle Bearing .....	1
38	799021	Brake Pad (pkg. of 2) .....	2	175	780145	Washer.....	1
39	786026	Dowel Pin .....	2				

# CRAFTSMAN 8HP MODEL 987.889000 REPAIR PARTS

## Craftsman 4-Cycle, 8HP Engine (Model 143.988000)

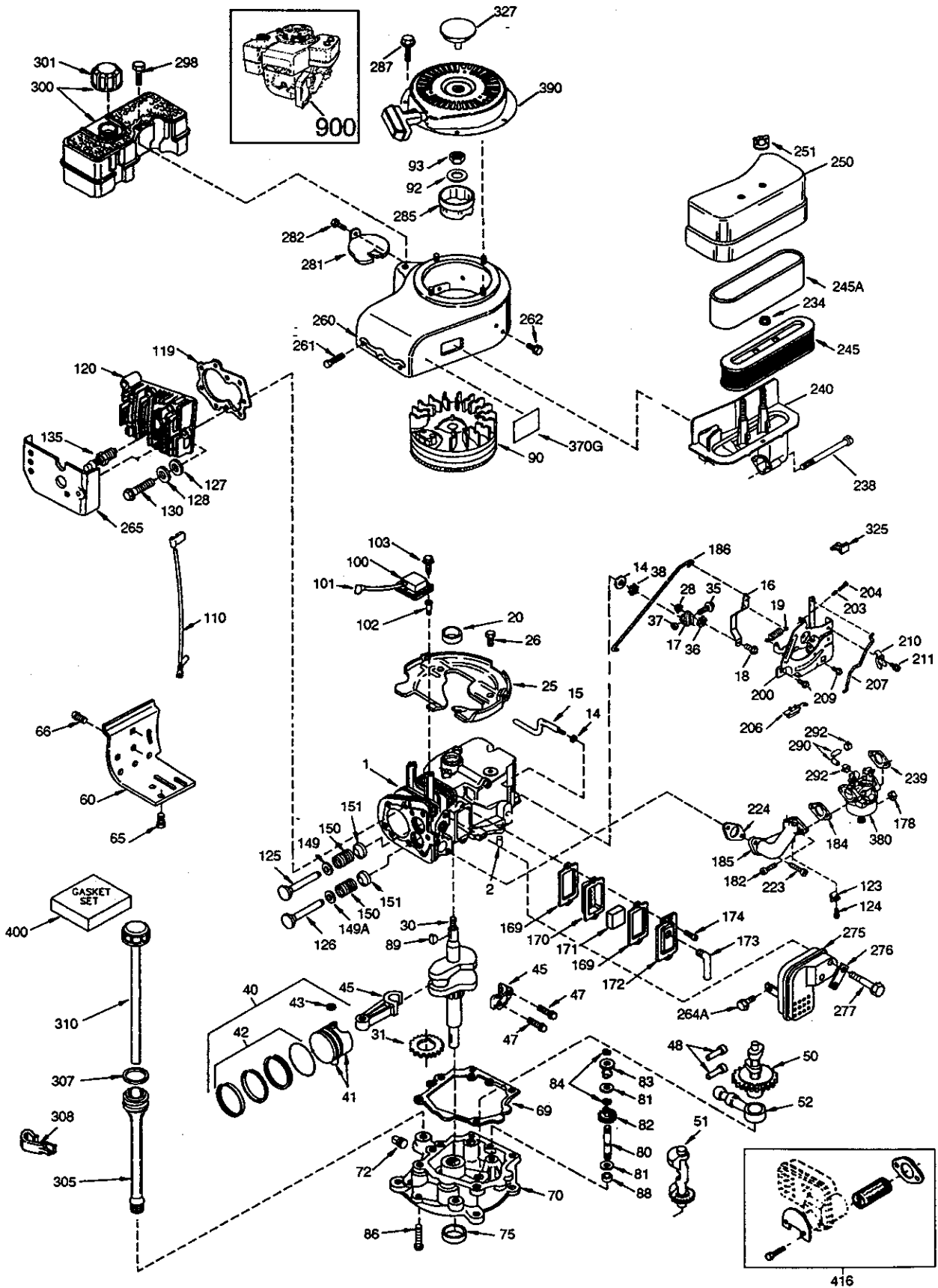

# CRAFTSMAN 8HP MODEL 987.889000 REPAIR PARTS

## Craftsman 4-Cycle, 8HP Engine (Model 143.988000)

### Engine Assembly

Ref #	Part #	Description	Qty	Ref #	Part #	Description	Qty	Ref #	Part #	Description	Qty
1	35745	Cylinder (Incl. 2 & 20)	1	119	36448	Cylinder Head Gasket	1	287	29752	Nut & Lock Washer, 1/4-28	4
2	27652	Dowel Pin	2	120	36449	Cylinder Head	1	290	30705	Fuel Line	1
14	28277	Washer	2	123	33261	Intake Pipe Brace	1	292	26460	Fuel Line Clamp	2
15	35082	Governor Rod	1	124	651031	Screw, 1/4-20 x 9/16"	3	298	28763	Screw, 10-35/64"	2
16	32651	Governor Lever	1	125	27878A	Exhaust Valve (Std.) (Incl. 151)	1	300	33583B	Fuel Tank (Incl. 292, 298 & 301)	1
17	29916	Governor Lever Clamp	1	125	27880A	Exhaust Valve (1/32" OS) (Incl. 151)	1	301	36246	Fuel Cap	1
18	651028	Screw, Torx T-15, 8-32 x 3/8"	1	126	34035	Intake Valve (Std.) (Incl. 151)	1	305	35574	Oil Fill Tube	1
19	34043	Extension Spring	1	126	34036	Intake Valve (1/32" OS) (Incl. 151)	1	307	35499	"O" ring	1
20	35319	Oil Seal	1	127	650691	Washer	9	308	35437	Fill Tube Clip	1
25	36460	Blower Housing Baffle	1	128	650690	Belleville Washer	9	310	35576	Dipstick	1
26	650561	Screw, 1/4-20 x 5/8"	2	130	650694A	Screw, 5/16-18 x 2"	9	325	29443	Wire Clip	1
28	30322	Lock Nut, 8-32	1	135	33636	Resistor Spark Plug (RJ17LM)	1	327	35392	Starter Plug	1
30	35746B	Crankshaft	1	149	27882	Valve Spring Cap	1	370G	35274	Oil Instruction Decal	1
31	35327	Counterbalance Gear	1	149A	35862	Valve Spring Cap	1	380	640126	Carburetor (Incl. 184)	1
35	29826	Screw, 10-32 x 3/4	1	150	27881	Valve Spring	2	390	590746	Rewind Starter	1
36	29918	Lock Washer	1	151	32581	Valve Spring Keeper	2	400	36450A	Gasket Set	1
37	29216	Lock Nut, 10-32	1	169	27896A	Valve Cover Gasket	2	(Incl. Items Marked PK in Notes) Incl. part #'s 27272A (1), 27896A (2), 27915A (1), 29673 (1), 33263 (1), 33629 (1), 34698A (1), 35262A (1), 36448 (1)			
38	29642	Retaining Ring	1	170	28423	Breather Body	1	416	34479A	Spark Arrestor Kit (option)	1
40	40011	Piston, Pin & Ring Set (Std.)	1	171	28424	Breather Element	1	900	--	Rep. short block 752314, order from 71-999	1
40	40012	Piston, Pin & Ring Set (.010" OS)	1	172	28425	Valve Cover	1	900	--	Replacement engine - none	1
41	40009	Piston & Pin Ass'y. (Std.) (Incl. 43)	1	173	35350	Breather Tube	1				
41	40010	Piston & Pin Ass'y. (.010" OS) (Incl. 43)	1	174	650128	Screw, 10-24 x 1/2"	2				
42	40013	Ring Set (Std.)	1	178	29752	Nut & Lock Washer, 1/4-28	2				
42	40014	Ring Set (.010" OS)	1	182	30088A	Screw, 1/4-28 x 1"	2				
43	27888	Piston Pin Retaining Ring	2	184	33263	Carburetor To Intake Pipe Gasket	1				
45	36897	Connecting Rod Ass'y. (Incl. 47)	1	185	34926	Intake Pipe	1				
47	651033	Connecting Rod Bolt	2	186	33860	Governor Link	1				
48	34034	Valve Lifter	2	200	33865B	Control Bracket	1				
50	35381	Camshaft (MCR)	1	203	31342	Compression Spring	1				
51	35747A	Counterbalance Weight	1	204	651029	Screw, Torx T-10, 5-40 x 7/16"	1				
52	31356	Oil Pump Ass'y.	1	206	610973	Terminal	1				
60	33273A	Blower Housing Extension	1	207	33151	Throttle Link	1				
65	650128	Screw, 10-24 x 1/2"	1	209	30200	Screw, 10-24 x 9/16"	2				
66	650990	Screw, Torx T-30, 1/4-20 x 15/32"	1	210	27793	Conduit Clip	1				
69	35317	Mounting Flange Gasket	1	211	28942	Screw, 10-32 x 3/8"	1				
70	35711A	Mounting Flange (Incl. 72, 75, 80 & 81)	1	223	650378	Screw, Torx T-30, 5/16-18 x 1-1/8"	2				
72	31927	Oil Drain Plug	1	224	27915A	Intake Pipe Gasket	1				
75	35319	Oil Seal	1	234	650825	Nut & Lock Washer, 1/4-20	2				
80	35783	Governor Shaft	1	238	650834	Screw, 10-32 x 1-17/32"	2				
81	30590A	Washer	2	239	33629	Air Cleaner Gasket	1				
82	35378	Governor Gear Ass'y. (Incl. 81)	1	240	35538B	Air Cleaner Body (Incl. 239)	1				
83	30588A	Governor Spool	1	245	35403	Air Cleaner Filter (Incl. 324)	1				
84	29193	Retaining Ring	2	245A	35404	Air Cleaner Filter	1				
86	650833	Screw, 1/4-20 x 1-3/16"	7	250	35961	Air Cleaner Cover	1				
88	31707A	Spacer (Incl. 81)	1	251	650886	Wing Nut, 1/4-20	2				
89	32589	Flywheel Key	1	260	33635C	Blower Housing	1				
90	611090	Flywheel	1	261	650788	Screw, 5/16-18 x 3/4"	2				
92	650880	Lock Washer	1	262	29747B	Screw, Torx T-40, 5/16-24 x 21/32"	2				
93	650881	Flywheel Nut	1	264A	650802	Screw, 1/4-20 x 5/8"	1				
100	35135	Solid State Ignition	1	265	33272B	Cylinder Head Cover (Black)	1				
101	610118	Spark Plug Cover	1	275	40003	Muffler	1				
102	651024	Solid State Mounting Stud	2	276	31588	Locking Plate	1				
103	651007	Screw, Torx T-15, 10-24 x 15/16"	2	277	650729	Screw, 5/16-18 x 3-3/16"	2				
110	35182	Ground Wire	1	281	33013	Starter Bubble Cover	1				
				282	650760	Screw, 8-32 x 3/8"	1				
				285	35985B	Starter Cup	1				

# CRAFTSMAN 8HP MODEL 987.889000 REPAIR PARTS

## Craftsman 4-Cycle, 8HP Engine (Model 143.988000)

### CARBURETOR NO. 640126

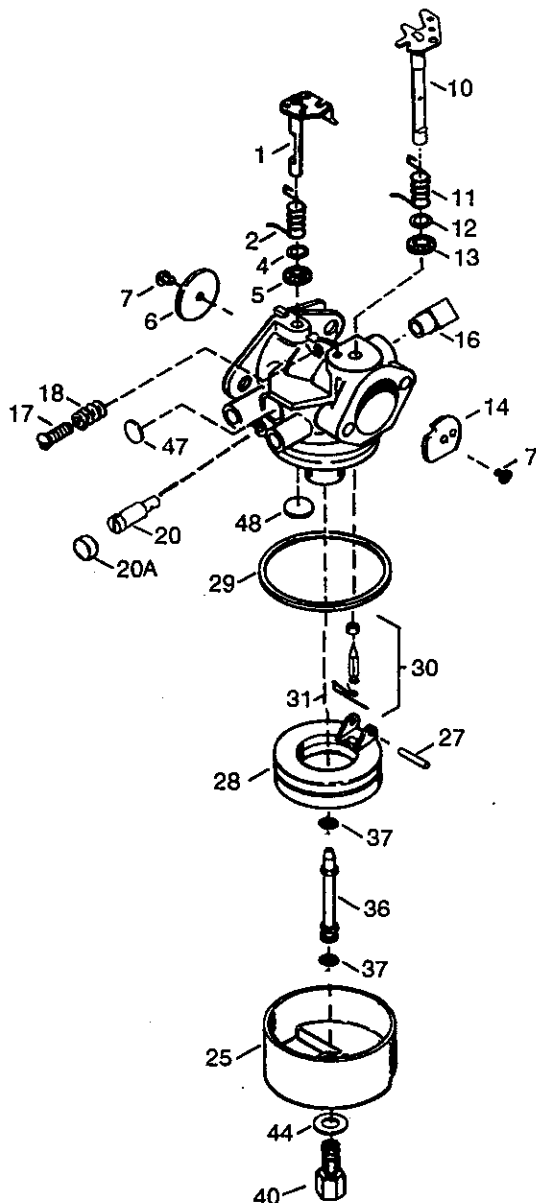

Ref #	Part #	Description	Qty.
0	640126	Carburetor (Incl. 184 of Engine Parts List)	1
1	631776A	Throttle Shaft & Lever Assembly	1
2	631970	Throttle Return Spring	1
4	631184	Dust Seal Washer	1
5	631183	Dust Seal (Throttle)	1
6	631778	Throttle Shutter	1
7	650506	Shutter Screw	2
10	631779	Choke Shaft & Lever Assembly	1
11	631780A	Choke Return Spring	1
12	631184	Dust Seal Washer	1
13	631183	Dust Seal (Choke)	1
14	631753	Choke Shutter	1
16	632527	Fuel Fitting	1
17	651025	Throttle Crack Screw/Idle Speed Screw	1
18	630766	Tension Spring	1
20	640027	Idle Restrictor Screw	1
20A	640053	Idle Restrictor Screw Cap	1
25	631867	Float Bowl	1
27	631024	Float Shaft	1
28	632019	Float	1
29	631028	Float Bowl "O" Ring	1
30	631021	Inlet Needle, Seat, & Clip (Incl. 31)	1
31	631022	Spring Clip	1
36	640005	Main Nozzle Tube	1
37	632547	"O" ring, Main Nozzle Tube	2
40	640012	High Speed Bowl Nut	1
44	27110	Bowl Nut Washer	1
47	630748	Welch Plug, Idle Mixture Well	1
48	631027	Welch Plug, Atmospheric Vent	1



# CRAFTSMAN 8HP MODEL 987.889000 REPAIR PARTS

## Craftsman 4-Cycle, 8HP Engine (Model 143.988000)

### RECOIL STARTER NO. 590746

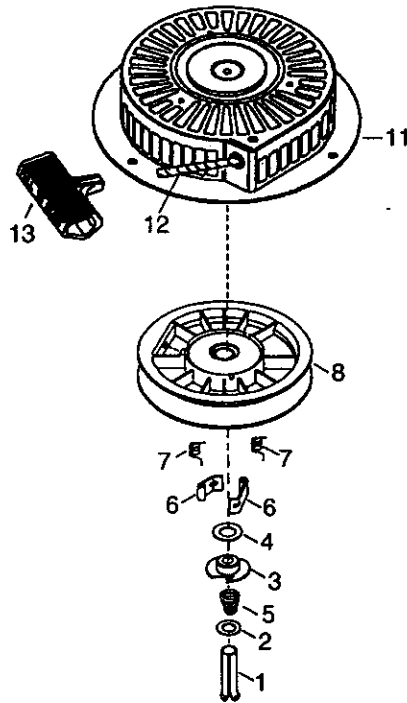

Ref #	Part #	Description	Qty.
0	590746	Recoil Starter	1
1	590599A	Spring Pin (Incl. 4)	1
2	590600	Washer	1
3	590679	Retainer	1
4	590601	Washer	1
5	590678	Brake Spring	1
6	590680	Starter Dog	2
7	590412	Dog Spring	2
8	590681	Pulley & Rewind Spring Ass'y.	1
11	590747	Starter Housing Ass'y.	1
12	590535	Starter Rope (Length 98" x 9/64" dia.)	1
13	590701	Starter Handle	1

---

# NOTES

---

---

# NOTES

---

# **SEARS**

## **OWNER'S MANUAL**

**MODEL NO.  
987.889000**

### **IF YOU NEED REPAIR SERVICE OR PARTS:**

FOR REPAIR SERVICE CALL  
THIS TOLL-FREE NUMBER:

**1-800-4-REPAIR**

(1-800-473-7247)

FOR REPLACEMENT PARTS  
INFORMATION AND ORDER-  
ING, CALL THIS  
TOLL-FREE NUMBER:

**1-800-FON-PART**

(1-800-366-7278)

# **CRAFTSMAN®**

## **8 Horsepower 33-INCH MOWER**

Each mower has its own model number. Each engine has its own model number.

The model number for your machine will be found on a decal attached to the right side of the mower deck.

The model number for the engine will be found on the engine housing.

All parts listed may be ordered through Sears, Roebuck and Co. Service Centers and most Retail Stores.

**WHEN ORDERING REPAIR PARTS, ALWAYS GIVE THE FOLLOWING INFORMATION:**

- PRODUCT – "MOWER"
- MODEL NUMBER – 987.889000
- ENGINE MODEL NO. – 143.988000
- PART NUMBER
- PART DESCRIPTION

Your Sears merchandise has added value when you consider that Sears has service units nationwide staffed with Sears trained technicians...professional technicians specifically trained on Sears products who have the parts, tools and the equipment to ensure that we meet our pledge to you...we service what we sell.

**Sears, Roebuck and Co., Hoffman Estates, Illinois 60179 U.S.A.**

## Free Manuals Download Website

<http://myh66.com>

<http://usermanuals.us>

<http://www.somanuals.com>

<http://www.4manuals.cc>

<http://www.manual-lib.com>

<http://www.404manual.com>

<http://www.luxmanual.com>

<http://aubethermostatmanual.com>

Golf course search by state

<http://golfingnear.com>

Email search by domain

<http://emailbydomain.com>

Auto manuals search

<http://auto.somanuals.com>

TV manuals search

<http://tv.somanuals.com>