

Owner's Manual

CRAFTSMAN[®]



42" HIGH PERFORMANCE LAWNSWEEPER

Model No's. 486.242221, 486.242241

DO NOT RETURN TO STORE
For Missing Parts or Assembly
Questions Call 1-866-576-8388

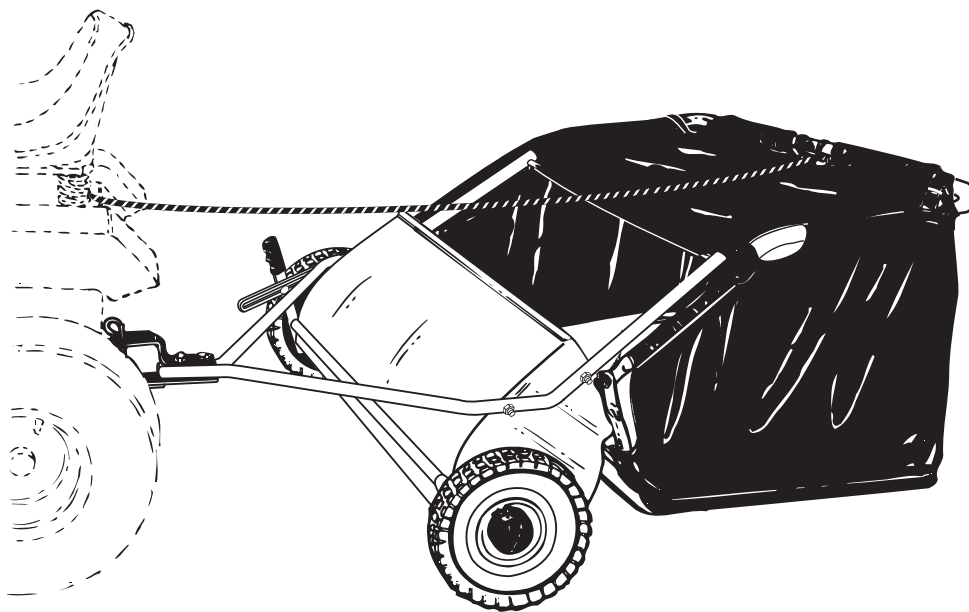

CAUTION:

Before using this product, read this manual and follow all Safety Rules and Operating Instructions.

- Safety
- Assembly
- Operation
- Maintenance
- Parts

Sears, Roebuck and Co., Hoffman Estates, IL 60179 U.S.A.
www.sears.com/craftsman

PRINTED IN U.S.A.

FORM NO. 40734 Rev (06/11/09)

TABLE OF CONTENTS

Safety Rules	1	Maintenance Schedule	13
Warranty	2	Storage	13
Accessories and Attachments	3	Service and Adjustments	14
Carton Contents	3	Troubleshooting	14
Full Size Hardware Chart	4	Repair Parts Illustration	15
Sweeper Assembly Instructions	5	Repair Parts List	16
Hopper Assembly Instructions	7	Parts Ordering/Service	Back Cover
Operation	12		

WARRANTY

CRAFTSMAN FULL WARRANTY

When operated and maintained according to all supplied instructions, if this Craftsman product fails due to a defect in material or workmanship within one year from the date of purchase, return it to any Sears store or other Craftsman outlet in the United States for free replacement.

This warranty applies for only 90 days from the date of purchase if this product is ever used for commercial or rental purposes. This warranty does not include items considered to be expendable parts that can wear out from normal use within the warranty period.

This warranty gives you specific legal rights, and you may also have other rights which vary from state to state.

Sears, Roebuck and Co., D817WA, Hoffman Estates, IL 60179

DO NOT RETURN TO STORE for Missing Parts or Assembly Questions

Call 1-866-576-8388 Attachment Hotline



SAFETY



Any power equipment can cause injury if operated improperly or if the user does not understand how to operate the equipment. Exercise caution at all times, when using power equipment.

1. Read the vehicle and sweeper owners manuals and know how to operate your vehicle and sweeper before using this sweeper attachment. Always instruct other users before they operate the sweeper.
2. Do not permit children to operate sweeper.
3. Do not permit anyone to ride on sweeper.
4. Never attach the hopper rope to any part of your body or clothing! Never hold onto the rope while towing the sweeper! Attach the rope to the towing vehicle to keep it away from wheels and rotating parts.
5. Operate the sweeper at reduced speed on rough terrain, near ditches and on hillsides to prevent loss of control.
6. Vehicle braking and stability may be affected with the attachment of this sweeper. Do not fill sweeper to maximum capacity without checking the capability of the towing vehicle to safely pull and stop with the sweeper attached. **Stay off of steep slopes.**
7. Stop and inspect vehicle and sweeper for damage after striking an object. Repair any damage before continuing operation.
8. Keep sweeper away from fire. Excessive heat can damage the brushes and hopper bag and could cause the bag and its contents to burn.
9. Before storing the sweeper, always empty the hopper bag to avoid spontaneous combustion.
10. Follow maintenance and lubrication instructions as outlined in the maintenance section of this manual.



Look for this symbol to point out important safety precautions. It means — **Attention!!**
Become alert!! Your safety is involved.

The model and serial numbers will be found on a decal attached to the lawnsweeper.

You should record both the serial number and the date of purchase and keep in a safe place for future reference.

MODEL NUMBER: 486.242221, 486.242241

SERIAL NUMBER: _____

DATE OF PURCHASE: _____

ACCESSORIES AND ATTACHMENTS

These accessories were available when the unit was purchased. They are also available at most Sears retail outlets and service centers. Most Sears stores can order repair parts for you when you provide the model numbers of your tractor and sweeper

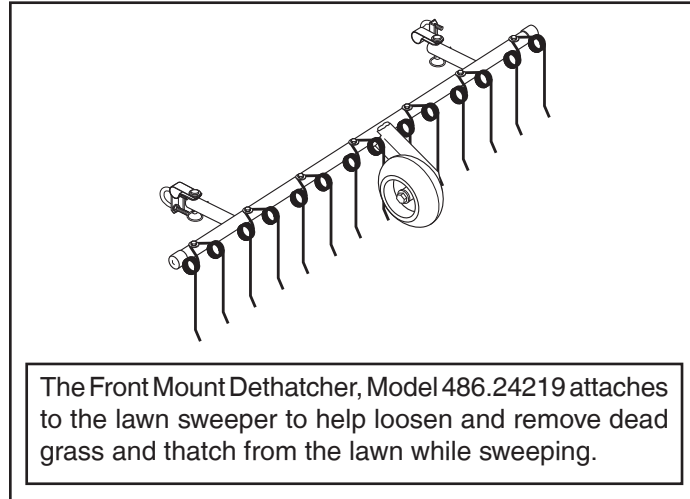

The Front Mount Dethatcher, Model 486.24219 attaches to the lawn sweeper to help loosen and remove dead grass and thatch from the lawn while sweeping.

CARTON CONTENTS (Loose Parts in Carton)

- | | | |
|---------------------------------|----------------------------------|------------------------------|
| 1. Sweeper Housing Assembly | 6. Height Adjustment Strap | 11. Upper Hopper Tube (2) |
| 2. Bag Arm Tube (2) | 7. Hitch Tube, R.H. (Right Hand) | 12. Lower Hopper Tube (2) |
| 3. Hitch Tube, L.H. (Left Hand) | 8. Rope | 13. Pivot Rod |
| 4. Hitch Bracket Assembly | 9. Hopper Bag | 14. Hopper Support Strap (2) |
| 5. Hitch Bracket, Bent | 10. Rear Hopper Tube (2) | 15. Bag Frame Strap |
| | | 16. Brush Assembly (2) |

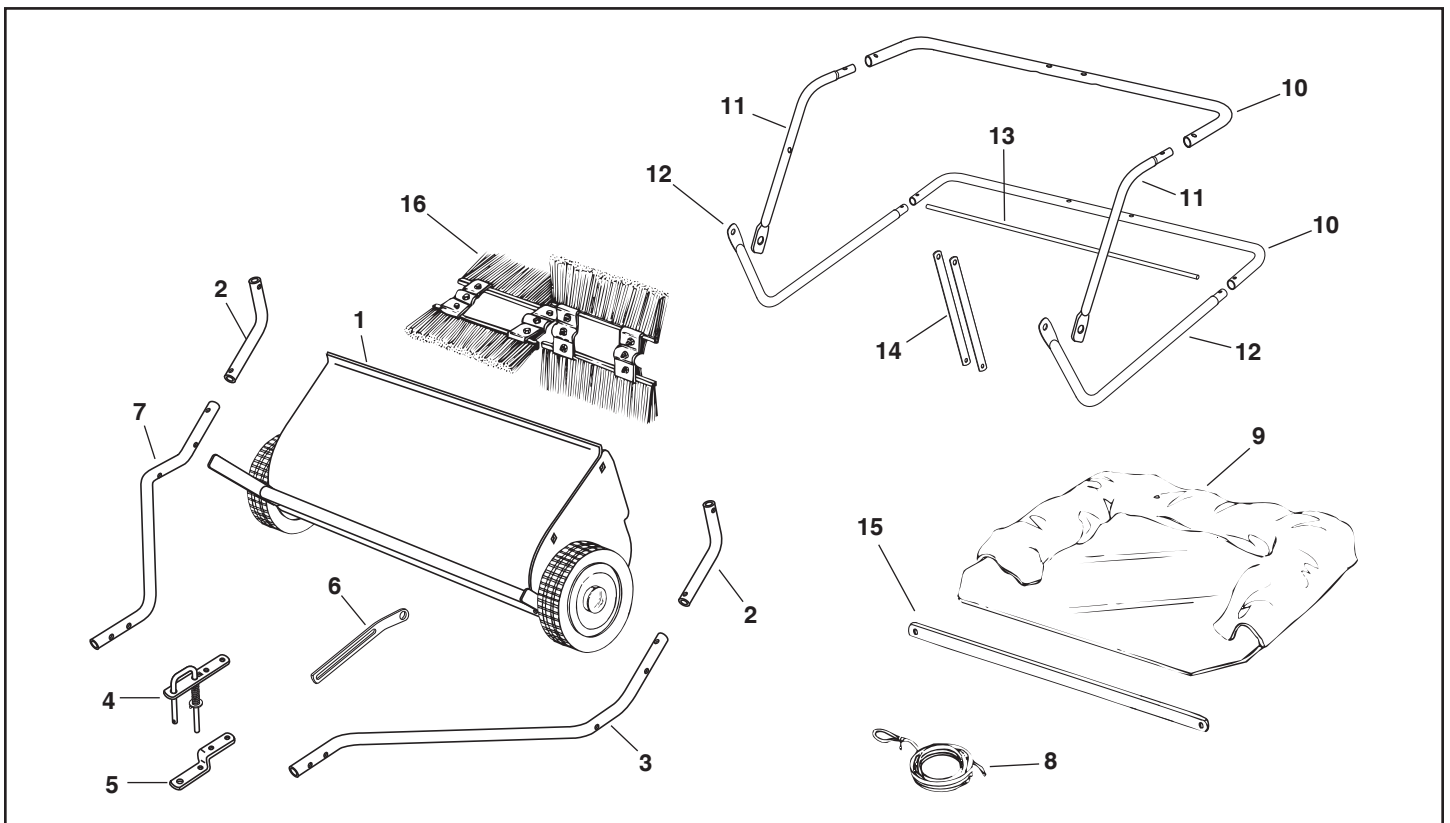

HARDWARE PACKAGE CONTENTS

SHOWN FULL SIZE

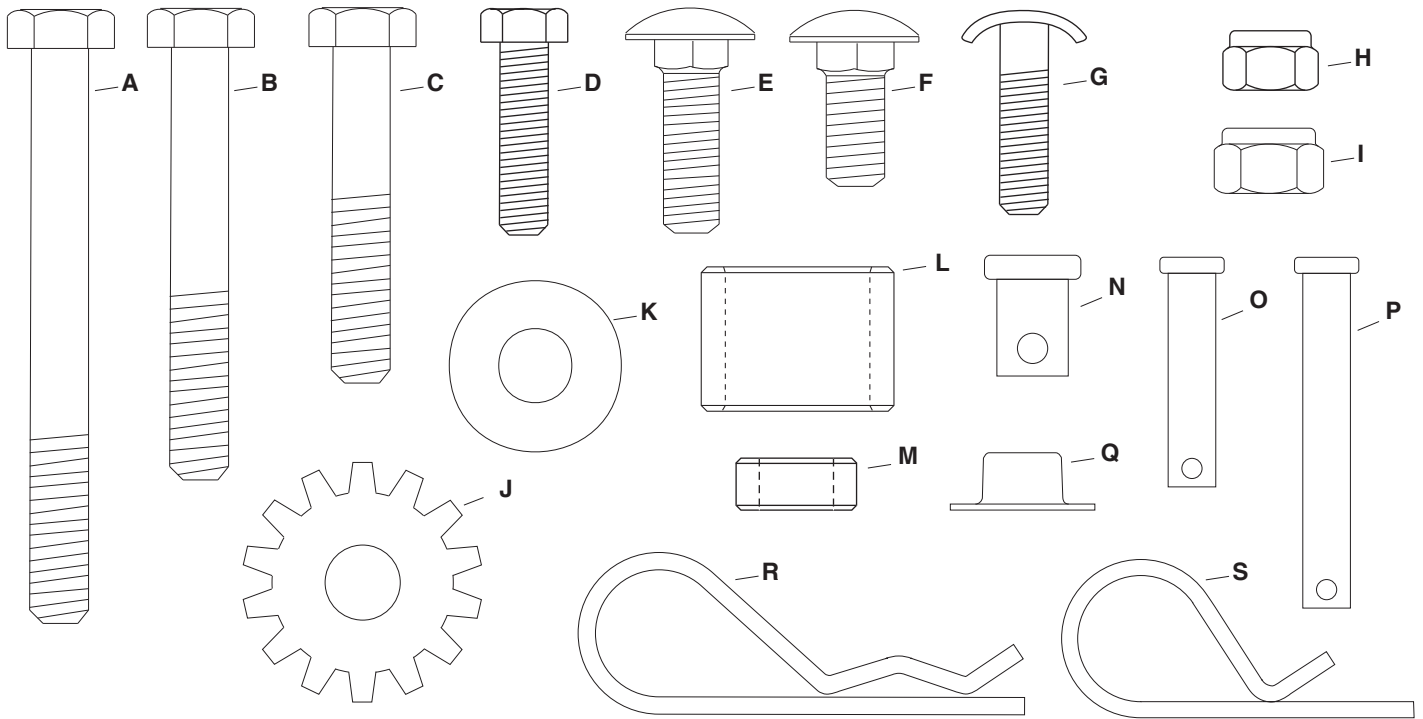

NOT SHOWN FULL SIZE



REF	QTY	DESCRIPTION	REF	QTY	DESCRIPTION
A	2	Hex Bolt, 5/16-18 x 3" Lg.	M	1	Spacer Bushing
B	3	Hex Bolt, 5/16-18 x 2-1/4" Lg.	N	2	Clevis Pin, 3/8" x 1/2"
C	3	Hex Bolt, 5/16-18 x 1-3/4" Lg.	O	4	Clevis Pin, 1/4" x 1-1/8"
D	4	Hex Bolt, 1/4-20 x 1"	P	2	Clevis Pin, 1/4" x 1-3/4"
E	1	Carriage Bolt, 5/16-18 x 1" Lg.	Q	2	Palnut, 3/8"
F	4	Carriage Bolt, 5/16-18 x 3/4" Lg.	R	1	Hairpin Cotter, 1/8"
G	4	Curved Head Bolt, 1/4-20 x 1"	S	8	Hairpin Cotter, 3/32"
H	8	Nylock Nut, 1/4"	T	4	Hopper Clamp
I	12	Nylock Nut, 5/16"	U	2	Vinyl Cap
J	1	Washer, Tooth Lock 5/16"	V	1	Grip
K	2	Flat Washer, 5/16" Standard	W	1	Plastic Knob
L	2	Hitch Spacer, 3/4"			

ASSEMBLY

TOOLS REQUIRED FOR ASSEMBLY

- (1) Hammer
- (2) 1/2" Wrenches
- (2) 7/16" Wrenches

STEP 1 - REMOVE PARTS FROM CARTON

- To protect painted parts, lay them on cardboard or a mat.
- Remove the sweeper housing, the loose parts and the hardware package from the carton. Lay out the parts and hardware as shown on pages 3 and 4.
- Place the sheet of cardboard from inside the carton onto your work surface to prevent scratching the sweeper.

STEP 2 - IDENTIFY BRUSH ASSEMBLIES

- Each brush assembly has one brush retainer marked with either red or black ink. Lay out the brush assemblies as shown so that the brush retainers marked with ink are in the middle with the black one on your right and the red one on your left. See figure 1.

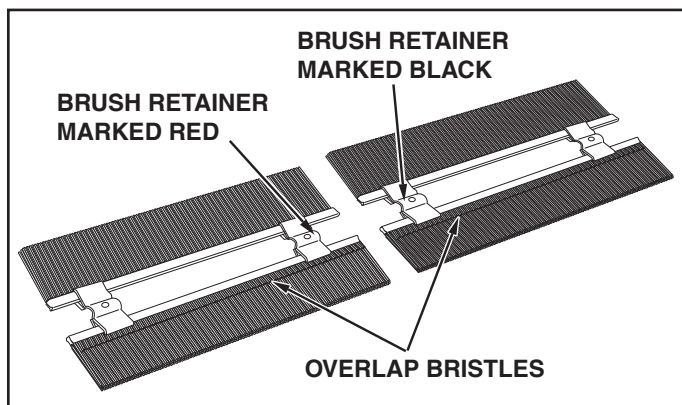

FIGURE 1

STEP 3 - ATTACH R.H. BRUSH ASSEMBLY

IMPORTANT: The overlap bristles at the bottom of each brush help support the back side of the brush for better sweeper performance. Be sure the sweeper is turned as shown in figure 2 to correctly assemble the brushes.

- Attach the brush assembly with the black brush retainer to the right end of the brush shaft using two hex bolts (D) and nylock nuts (H). The brush retainer marked with black ink must be placed to the **middle** of the sweeper. See figure 2.

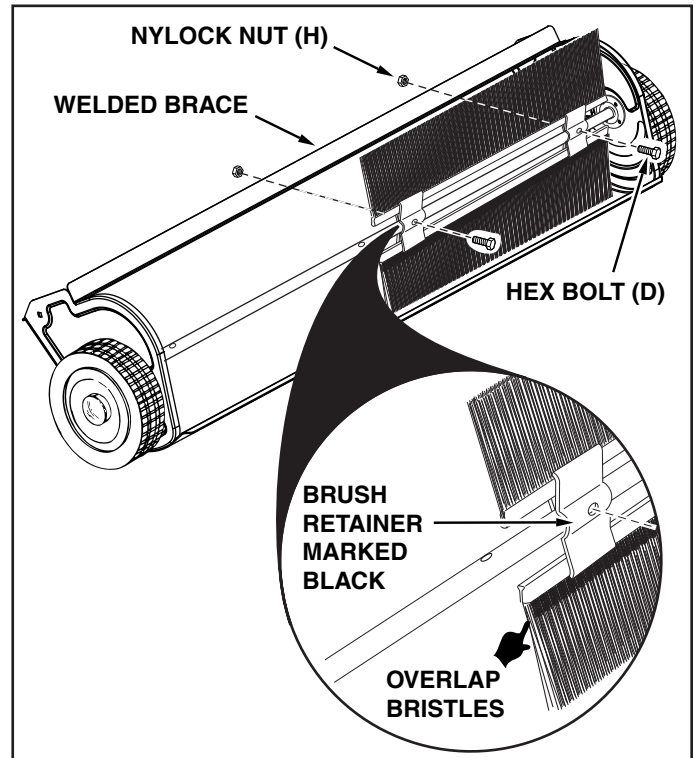

FIGURE 2

STEP 4 - ATTACH L.H. BRUSH ASSEMBLY

- Attach the brush assembly with the red brush retainer to the left end of the brush shaft using two hex bolts (D) and nylock nuts (H). The brush retainer marked with red ink must be placed to the **middle** of the sweeper. See figure 3.
- Turn a wheel to rotate the brushes. (The wheels drive the brushes in one direction only.) The overlap bristles should be on the back side of the brush as it rotates.

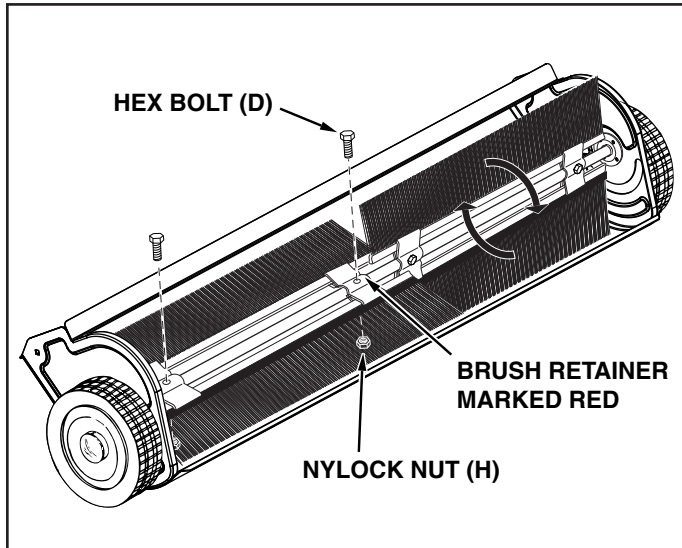

FIGURE 3

STEP 5 - ASSEMBLE LEFT HITCH TUBE

- The hitch tubes are stamped with a "77L" for the left tube and a "76R" for the right tube. The sweeper housing is marked with an "L" on the left with side and an "R" on the right side. See figures 4 and 5.
- Hold the left hitch tube against the left side of the sweeper so that the "77L" on the tube faces **away** from the sweeper. Attach the hitch tube using two hex bolts (C) and nylock nuts (I). **Do not tighten yet.** See figure 4.

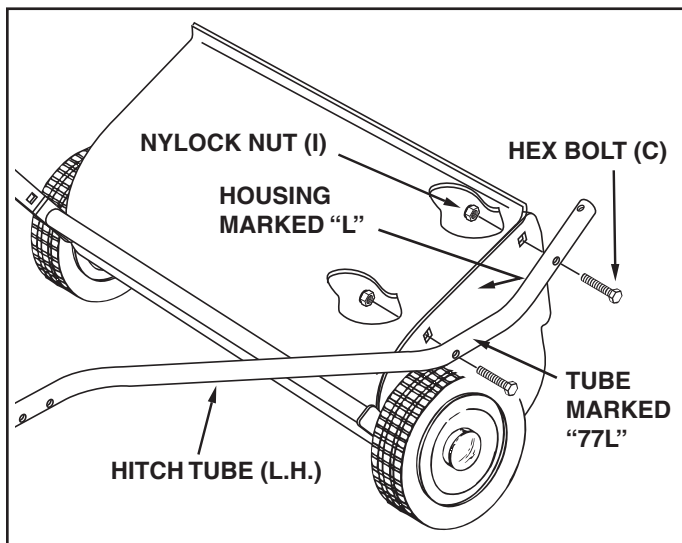

FIGURE 4

STEP 6 - ASSEMBLE RIGHT HITCH TUBE

- Hold the right hitch tube against the right side of the sweeper so that the "76R" on the tube faces **toward** the sweeper. Attach the hitch tube using one hex bolt (C) and nylock nut (I). **Do not tighten yet.** See figure 5.

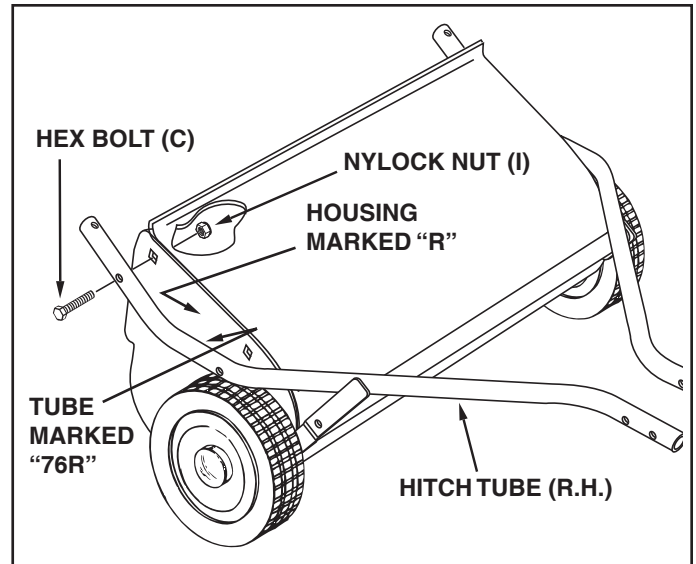

FIGURE 5

STEP 7 - ASSEMBLE HEIGHT ADJ. STRAP

- Attach the height adjustment strap to the hitch tube using a hex bolt (B), the spacer bushing (M), a flat washer (K) and a nylock nut (I). See figure 6. **Do not tighten yet.**

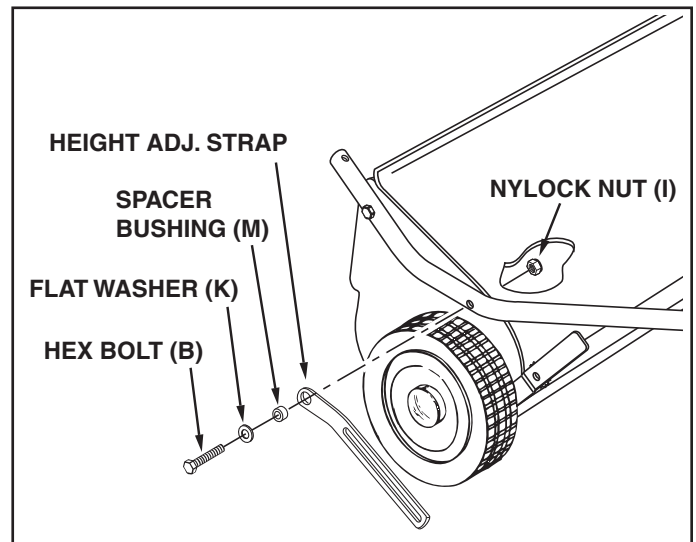

FIGURE 6

STEP 8 - ASSEMBLE KNOB

- Place the height adjustment strap to the **inside** of the height adjustment handle. Place the star washer (J) **between** the height adjustment strap and the height adjustment handle. Insert the carriage bolt (E) through the strap, the star washer and the handle. Assemble the flat washer (K) and the plastic knob (W) onto the end of the bolt and tighten. See figure 7.

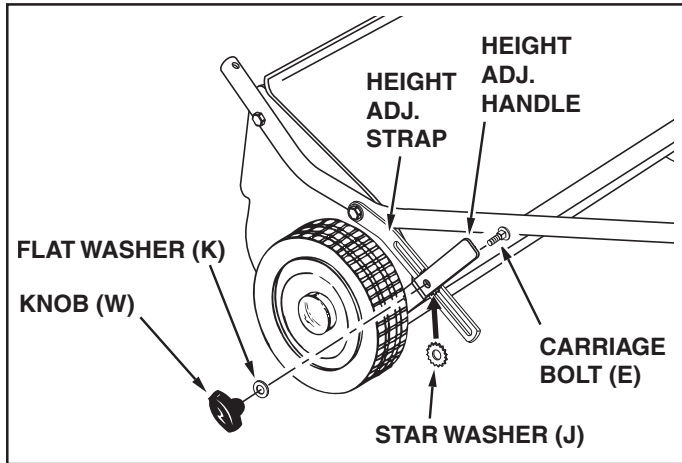

FIGURE 7

STEP 9 - FASTEN HITCH TUBES TOGETHER

- Fasten the hitch tubes together using two hex bolts (A) and nylock nuts (I). See figure 8. **Do not tighten yet.**

STEP 10 - ASSEMBLE GRIP

- Assemble the grip (V) onto the end of the height adjustment handle as shown in figure 8.

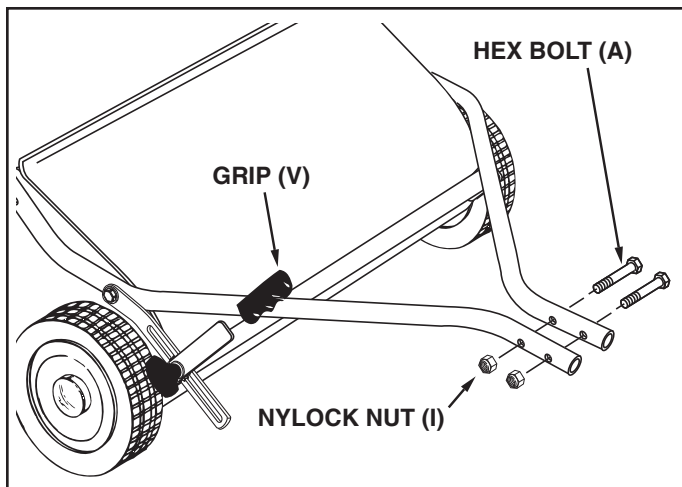

FIGURE 8

STEP 11 - MEASURE TRACTOR HITCH HEIGHT

- Use the mark along the side of this page to measure the height of the tractor hitch. The mark is 10" from the bottom of the page. If the tractor hitch is less than 10" above the ground, go to **STEP 12a**. If the tractor hitch is 10" or more above the ground, go to **STEP 12b**.

STEP 12a - ASSEMBLE HITCH BRACKETS

- If the tractor hitch is less than 10" above the ground, assemble the hitch brackets as shown in figure 9. Insert two hex bolts (B) through the brackets, with the rear hex bolt between the cross bolts in the hitch tubes. Secure the hex bolts (B) with two nylock nuts (I). **Do not tighten yet.** See figure 9.
- Assemble the two spacers (L) onto the hitch pin and secure the pin with the hairpin cotter (R). See figure 9.

10"

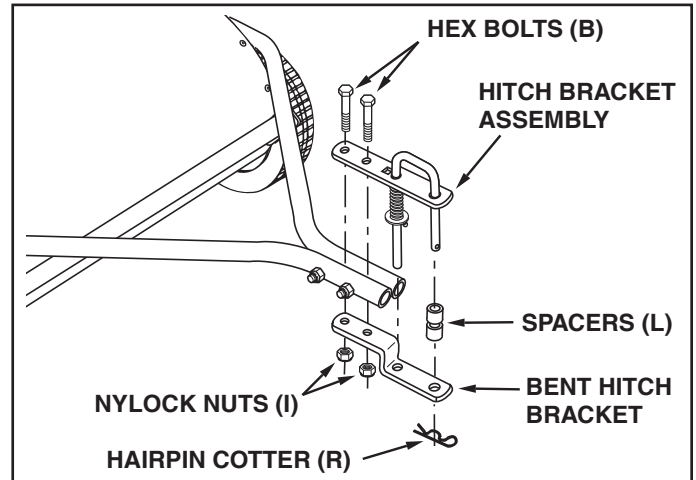

FIGURE 9

STEP 12b - ASSEMBLE HITCH BRACKETS

- If the tractor hitch is 10" or more above the ground, assemble the hitch brackets as shown in figure 10. Insert two hex bolts (B) through the brackets, with the rear hex bolt between the cross bolts in the hitch tubes. Secure the hex bolts (B) with two nylock nuts (I). **Do not tighten yet.** See figure 10.
- Assemble the two spacers (L) onto the hitch pin and secure the pin with the hairpin cotter (R). See figure 10.

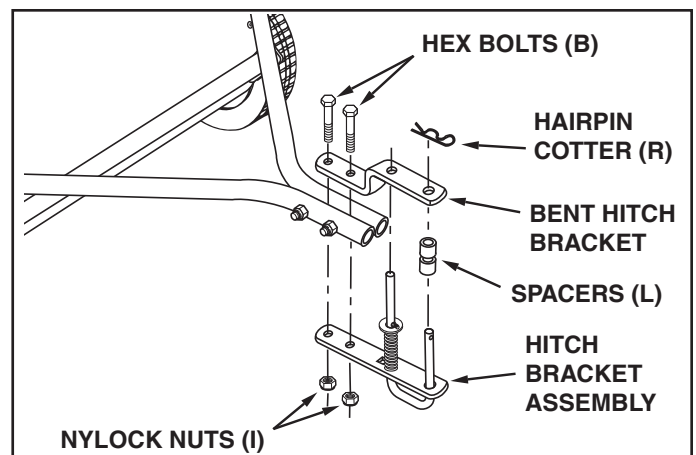

FIGURE 10

STEP 13 - TIGHTEN BOLTS

- Tighten** the four bolts assembled in steps 5, 6 and 7. **Tighten** the two bolts assembled in step 9. **Tighten** the two bolts assembled in step 12a or 12b.

ASSEMBLY OF HOPPER BAG

STEP 14 - ASSEMBLE TUBES

- Fit the ends of the two upper hopper tubes into the ends of a rear hopper tube. Align the holes in the ends of the tubes and secure them in place using two curved head bolts (G) and nylock nuts (H). See figure 11.
- Fit the ends of the two lower hopper tubes into the ends of a rear hopper tube. Align the holes in the ends of the tubes and secure them in place using two curved head bolts (G) and nylock nuts (H). See figure 11.
- Insert a clevis pin (O) from the outside into each lower hopper tube and secure it with a hair cotter pin (S). See figure 11.

NOTE: Either side of the rear hopper tube can face up.

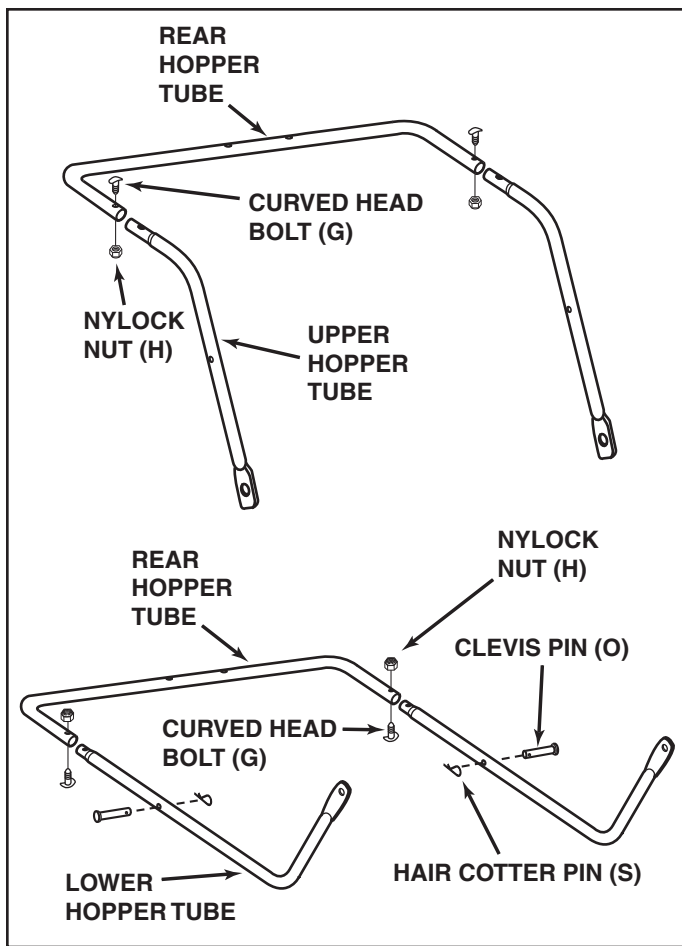

FIGURE 11

STEP 15 - ASSEMBLE TUBES TO BAG

- Unfold the hopper bag, reverse the fold of the mesh wind screen and then lay the bag out flat with the wind screen on top.
- Insert the ends of the assembled upper hopper tubes down through the stitched sleeves in the sides of the hopper bag and then slide the tubes back underneath the wind screen. See figure 12.

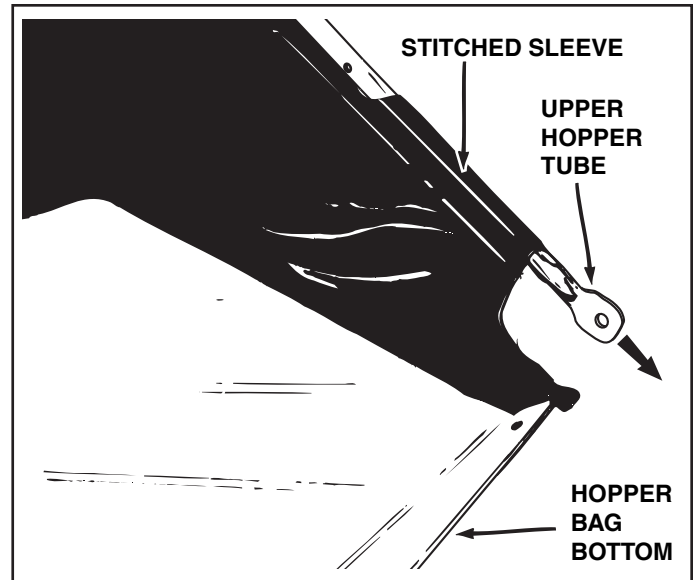

FIGURE 12

- Place the assembled lower hopper tubes into the bottom of the hopper bag and then slide the tubes to the back of the bag. See figure 13.
- Attach the ends of the lower hopper tubes to the **inside** of the upper hopper tubes using two clevis pins (N) inserted from the inside, and two hair cotter pins (S). See figure 13.

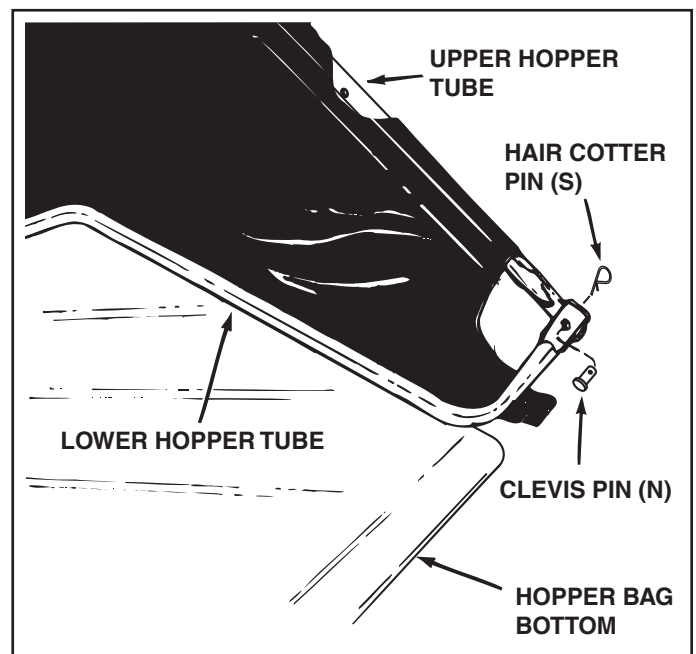

FIGURE 13

STEP 16 - ATTACH BAG BOTTOM

- Insert the bag frame strap into the stitched sleeve at the front edge of the bag bottom. See figure 14.

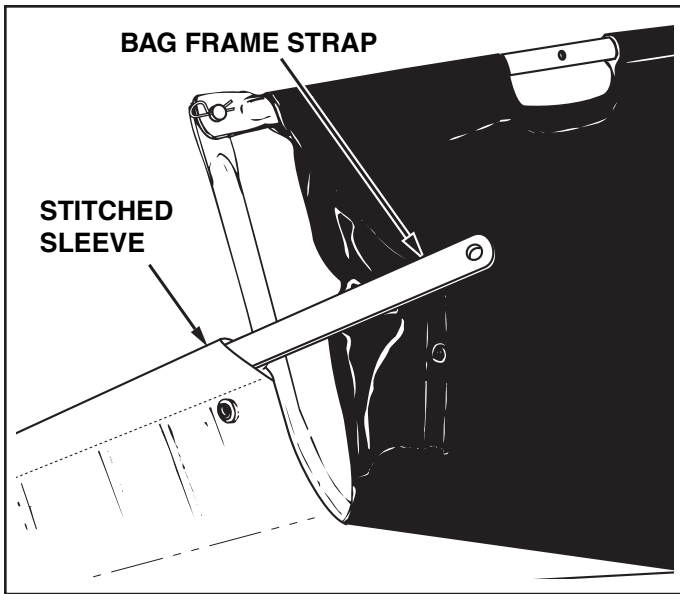

FIGURE 14

- Fold the bag flaps around the lower hopper tubes and attach to the bag bottom using the snaps. See figure 16.

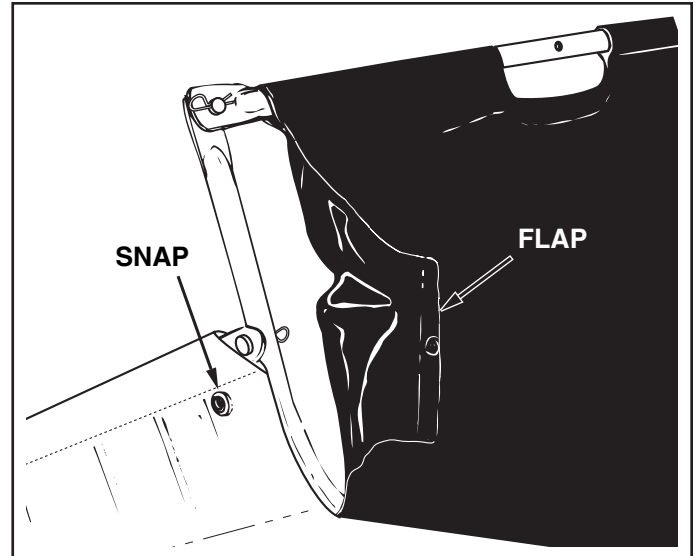

FIGURE 16

- Assemble the bag frame strap to the holes in the lower hopper tubes using two clevis pins (O) and hair cotter pins (S). See figure 15.

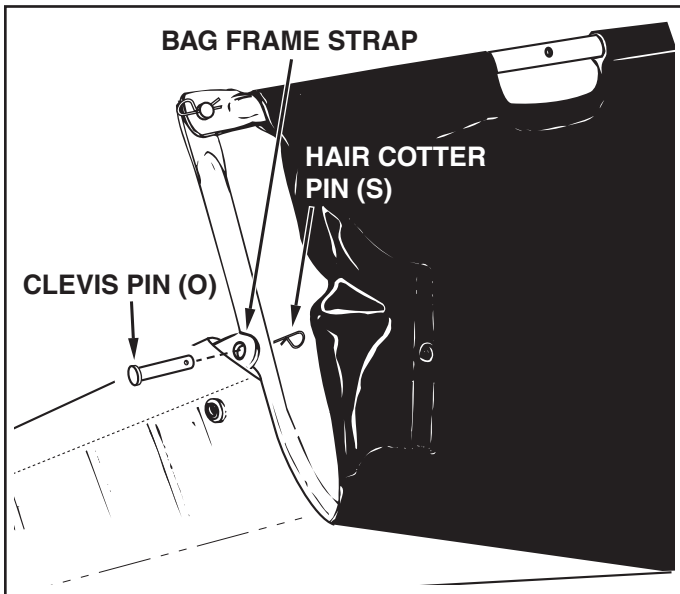

FIGURE 15

STEP 17 - ASSEMBLE HOPPER CLAMPS

- Assemble two hopper mount clamps (T) over the hole in the middle of each upper hopper tube using two carriage bolts (F) and two nylock nuts (I). Tighten only finger tight. See figure 17.

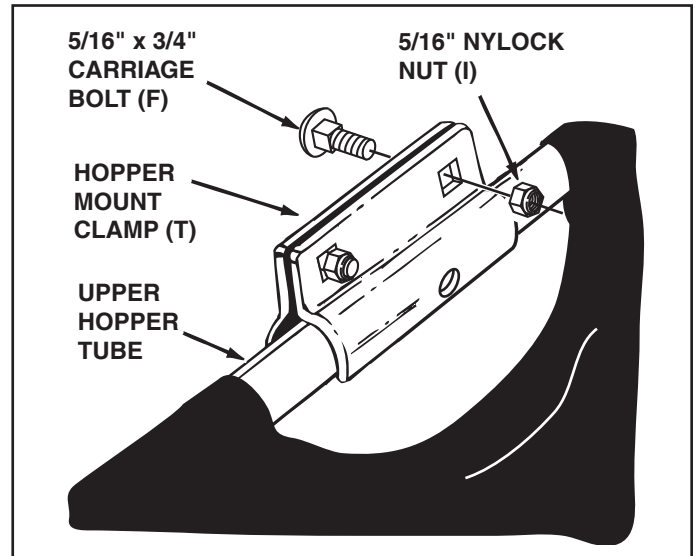

FIGURE 17

STEP 18 - ASSEMBLE PIVOT ROD

- Slide the end of the pivot rod through the upper hopper tube and the hopper mount clamps on one side of the hopper. Place a hopper support strap and then a bag arm tube onto the rod. Slide the rod through the stitched sleeve at the front edge of the wind screen, and then place another bag arm tube and a hopper support strap onto the rod. Slide the rod through the other upper hopper tube and hopper mount clamps. See figure 18.

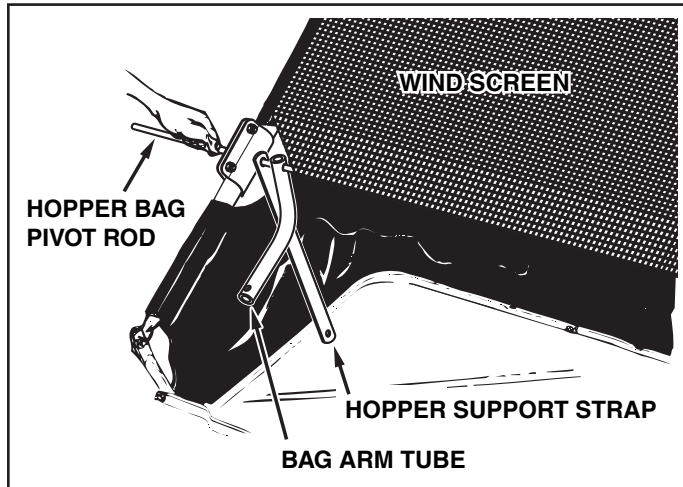

FIGURE 18

- Attach the bottoms of the hopper support straps to the clevis pins (O) in the lower hopper tubes, securing the straps with the previously assembled hair cotter pins (S). See figure 19.
- Tighten the nuts on the hopper mount clamps. See figure 19.

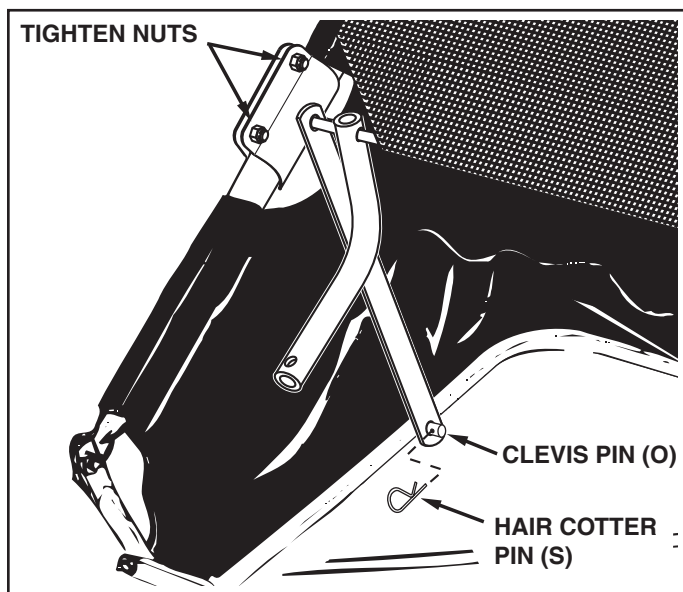

FIGURE 19

- Assemble a vinyl cap (U) onto each bag arm tube as shown in figure 20.
- Assemble two palnuts (Q) onto the ends of the pivot rod using a hammer. See figure 20.

HINT: To ease assembly of the palnuts, place the bag on its side on a solid surface. With the bottom end of the pivot rod against the surface, tap a palnut onto the top end of the rod. Repeat for other end of rod.

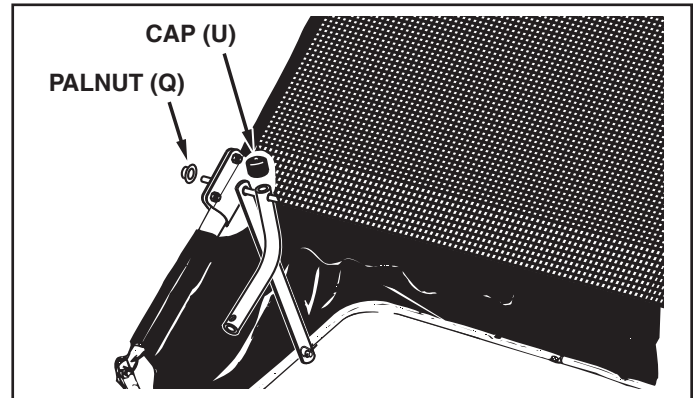

FIGURE 20

STEP 19 - ATTACH ROPE

- Secure the rope to the center of the upper rear hopper tube as shown in figure 21.



FIGURE 21

STEP 20 - ATTACH HOPPER BAG

- To attach the hopper bag to the sweeper, slide the ends of the bag arm tubes into the ends of the hitch tubes and secure with two clevis pins (P) and hairpin cotters (M). See figure 22.

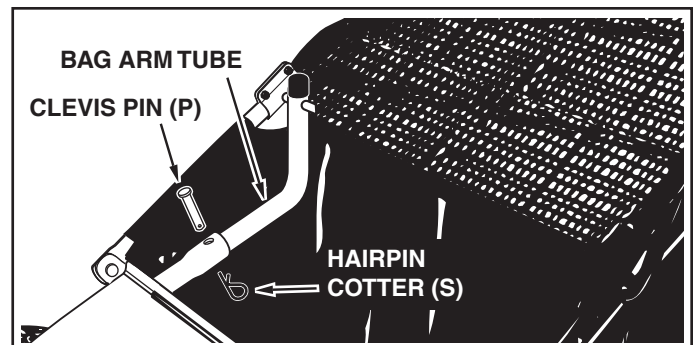

FIGURE 22

ATTACHING SWEEPER HITCH TO TRACTOR

- Place the tractor and sweeper on a flat level surface.
- Set the sweeper height adjustment handle to about the middle of its adjustment range.
- Attach the sweeper hitch to the tractor hitch, arranging the 3/4" spacers in one of six possible combinations as shown in GROUP A and GROUP B diagrams below.

IMPORTANT: To obtain the best performance from your sweeper, arrange the spacers so that the sweeper bag is approximately level with the ground and approximately 5" to 7" off the ground as shown in figure 23.

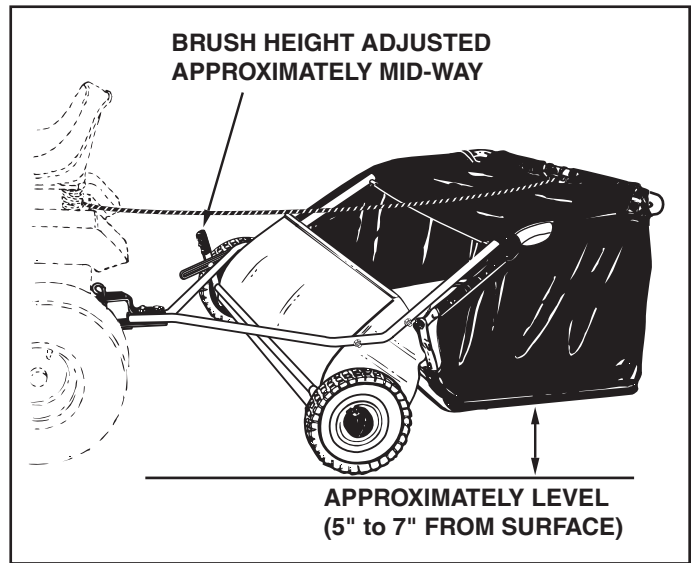
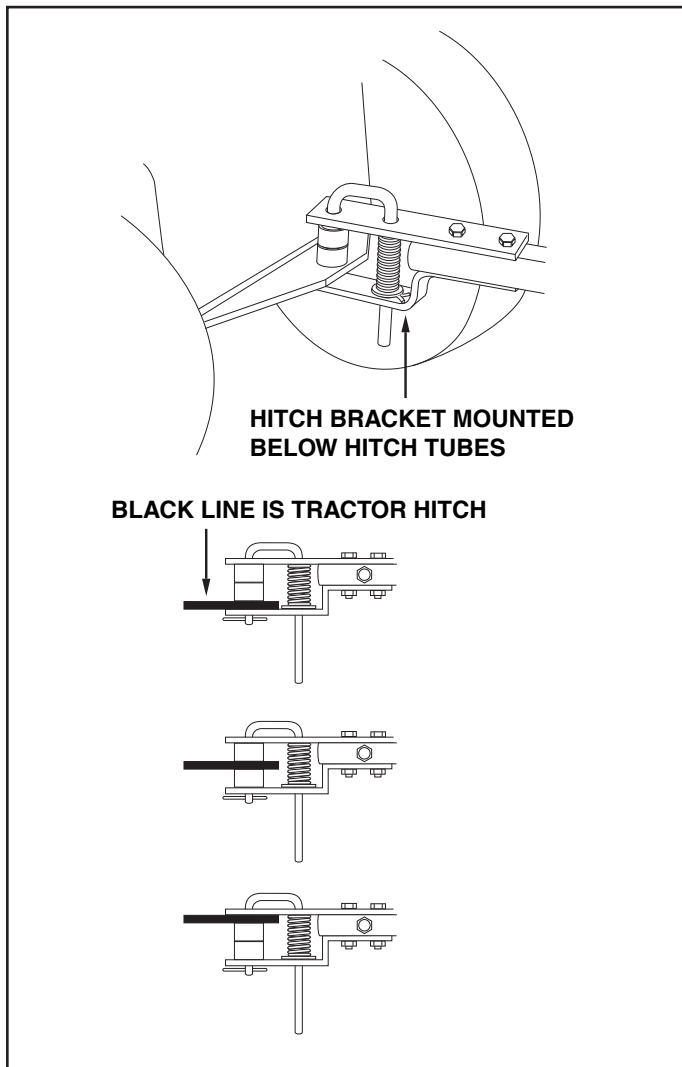
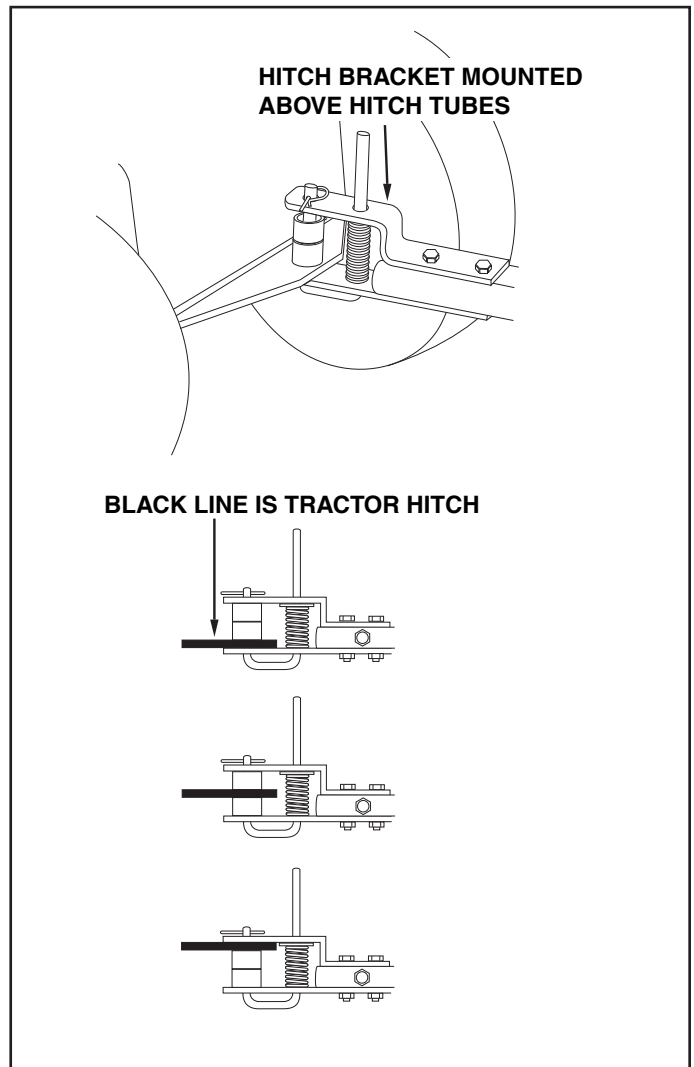

FIGURE 23

GROUP "A" - For vehicles with hitches having 8" to 10" ground clearance.



GROUP "B" - For vehicles with hitches having 10" to 13" ground clearance.



OPERATION

KNOW YOUR SWEEPER

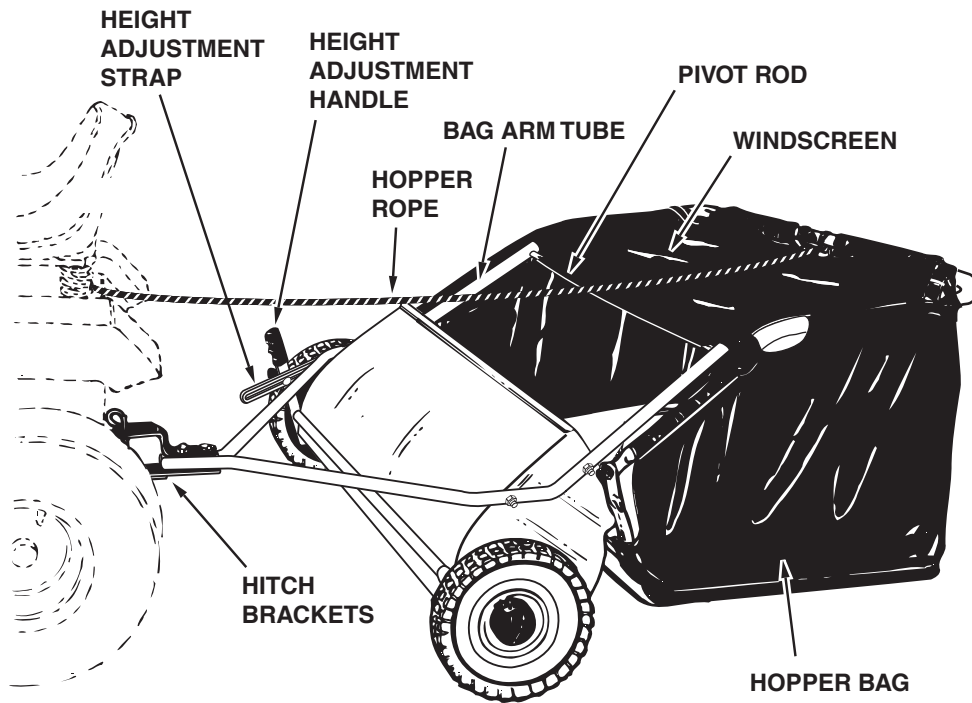

Hopper Bag	Collects grass clippings, leaves and debris.
Hopper Rope	Permits dumping of hopper bag from driver's seat.
Windscreen	Helps prevent collected material from being blown out of hopper bag.
Bag Arm Tubes	Connects the hopper bag to the sweeper housing.
Pivot Rod	Allows hopper bag to tilt forward to dump material.
Height Adjustment Handle	Adjusts the operating height of the sweeper.
Height Adjustment Strap	Holds the height adjustment handle in position when locked.
Hitch Bracket	Connects the sweeper to the towing vehicle. Adjusts for various height tractor hitches.

HOW TO USE YOUR SWEEPER

BRUSH HEIGHT ADJUSTMENT

- To adjust your sweeper brushes to the best operating height, loosen the adjustment knob and push down on the height adjustment handle to raise the brush, or push up on the handle to lower the brush. See figure 19. Best adjustment is when the brush setting is 1/2" down into the grass. Always mow the grass to an even height before sweeping.

SWEEPING SPEED

- Try a starting speed of approximately 3 m.p.h. (third gear on most tractors). Depending on the conditions, it may be necessary to adjust the sweeping speed in order to achieve best results.

DUMPING OF SWEEPER

- Your sweeper can be dumped easily without getting off of the rider or tractor. Simply pull the rope forward to dump the hopper. Always empty hopper after each use.



CAUTION: Never attach the hopper rope to any part of your body or clothing! Never hold onto the rope while towing the sweeper! Attach the rope to the towing vehicle to keep it away from wheels and rotating parts.



CAUTION: Keep sweeper away from fire. Excessive heat can damage the brushes and hopper bag and could cause the bag and its contents to burn.

MAINTENANCE

CUSTOMER RESPONSIBILITIES

- Read and follow the maintenance schedule and the procedures listed in the maintenance section.

MAINTENANCE SCHEDULE Fill in dates as you complete regular service.	Service Dates					
	Before each use	After each use	Twice a year	Every season	Before storage	Every two years
Check for loose fasteners	X					
Check for worn or damaged parts	X		X			
Lubricate brush shaft bearings		X				
Lubricate wheel bearings			X			
Clean Sweeper	X			X		
Clean/Lubricate chain and sprockets					X	

SCHEDULED MAINTENANCE

- Clean the sweeper after each use.
- Inspect for worn or damaged parts, such as brushes and wheels.
- Lubricate the brush shaft bearing twice a year with a few drops of light weight oil. See figure 24.

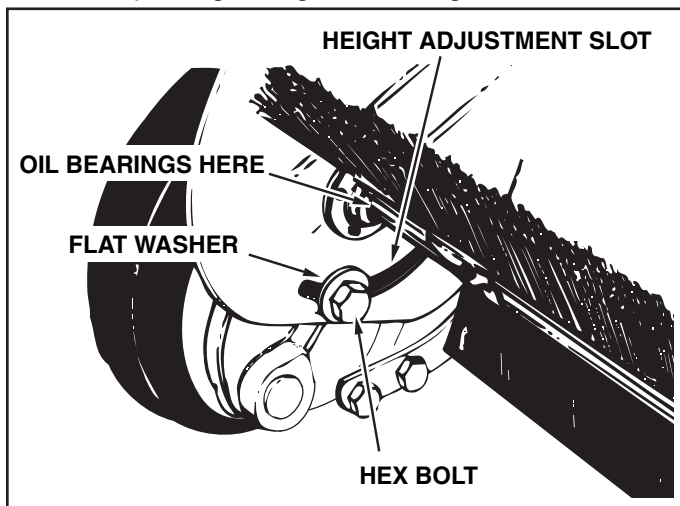

FIGURE 24

- Every two years, remove the wheels and clean the sprockets, chains and gears found inside the wheel housing. After cleaning, lubricate with an even coat of light grease. To remove the wheel, pop off the hub cap using a screwdriver and remove the lock nut and flat washer. See figure 25.

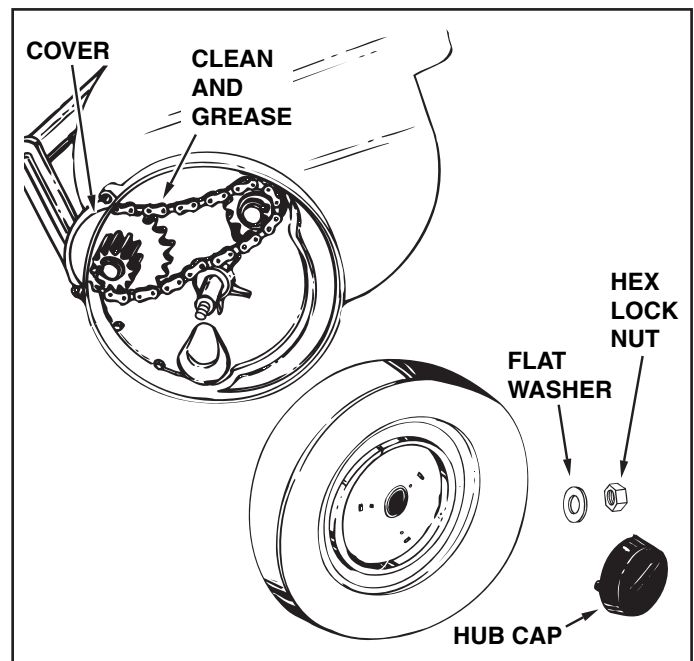

FIGURE 25

CLEANING

- Clean sweeper housing with a soft brush or cloth.
- Clean debris from hopper bag with a brush or broom.
- Remove any material which has wrapped around brushes or ends of brush shaft.

STORAGE



CAUTION: Before storing the sweeper, always empty the hopper bag to avoid spontaneous combustion.

- Clean the sweeper and hopper bag thoroughly to help prevent rust and mildew.
- To collapse the hopper bag for storage, remove the two hopper support rods from the rear of the hopper.
- Store in a dry area.

SERVICE AND ADJUSTMENTS

BRUSH REPLACEMENT

NOTE: Brush replacement should be done one brush at a time.

- Remove the hopper bag from the sweeper.
- Loosen the hex bolts and lock nuts on two single brush retainers which clamp one brush to the double brush retainers. **Do Not loosen** or remove the bolts which fasten the double brush retainers to the brush shaft. See figure 26.
- Slide the brush out of the retainers, noting on which side of the brush the bristles overlap. See figure 26.
- Install new brush, making sure the bristles overlap on the same side of the brush as before. See figure 26.

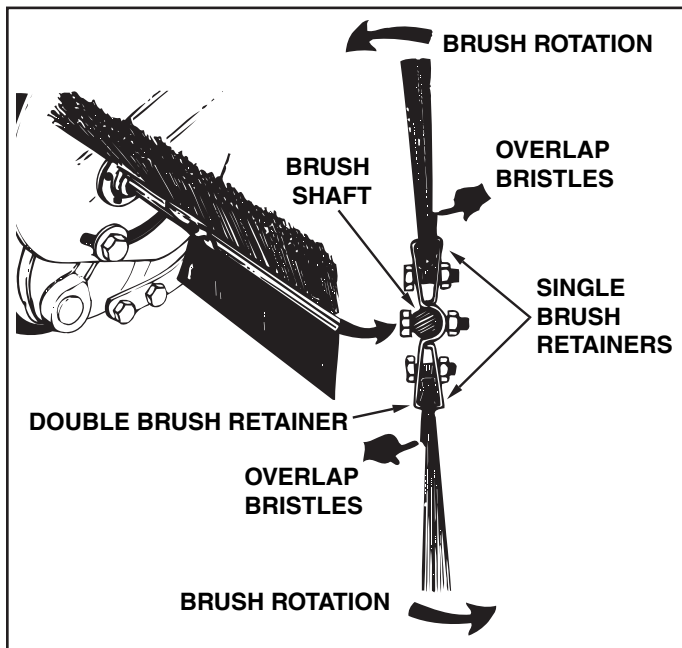

FIGURE 26

SPROCKET, CHAIN AND PAWL SERVICE

IMPORTANT: Do not remove both wheels at the same time to avoid mixing of parts. (The R.H. and L.H. ratchet sprockets are not interchangeable.) **Make notes** on the position of washers and snap rings during disassembly.

- Remove the dust cover by removing the two rivets which fasten it to the wheel housing. (It is not necessary to remove the dust cover if you are only cleaning and lubricating the chain and sprockets.)
- Remove the retaining rings and washers which hold the sprockets onto the shafts.
- Remove the chain and both sprockets, holding them in position and sliding them off both of the shafts. (Look for the drive pin, which may fall out of the brush shaft when the ratchet sprocket is removed.) See figure 27.
- To reassemble, insert the drive pin through the hole at the end of the brush shaft. Make sure the pin slides back and forth easily in the shaft.
- Lightly grease both shafts and the chain, and fill the ratchet sprocket with grease. Assemble the chain with both sprockets back onto the shafts.
- Lightly grease the axle and then reassemble the wheel. The brushes should rotate **only** during forward rotation of the wheel. If the brushes are driven (rotated) by both forward and reverse rotation of the wheel, the drive pin is jamming in the ratchet gear. Disassemble and clean and lubricate the drive pin and ratchet gear.

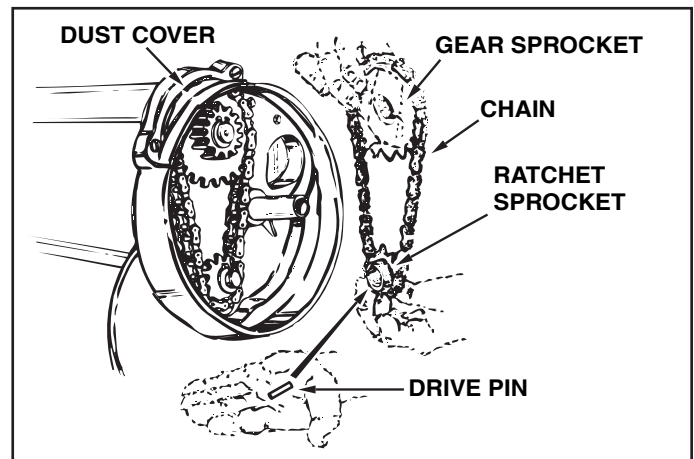

FIGURE 27

TROUBLESHOOTING

Wheels skid when sweeping.	<ul style="list-style-type: none">• Brushes set too low.• Brushes are jammed• Wheels are jammed.	<ul style="list-style-type: none">• Adjust height till brushes are 1/2" down into grass.• Stop sweeper. Remove obstruction.• Remove one wheel at a time to check for obstruction or damage. Refer to Service and Adjustments section.
----------------------------	--	---

NOTES

PARTS

REPAIR PARTS LIST FOR MODELS 486.242221, 486.242241 42" HIGH PERFORMANCE LAWSWEEPER

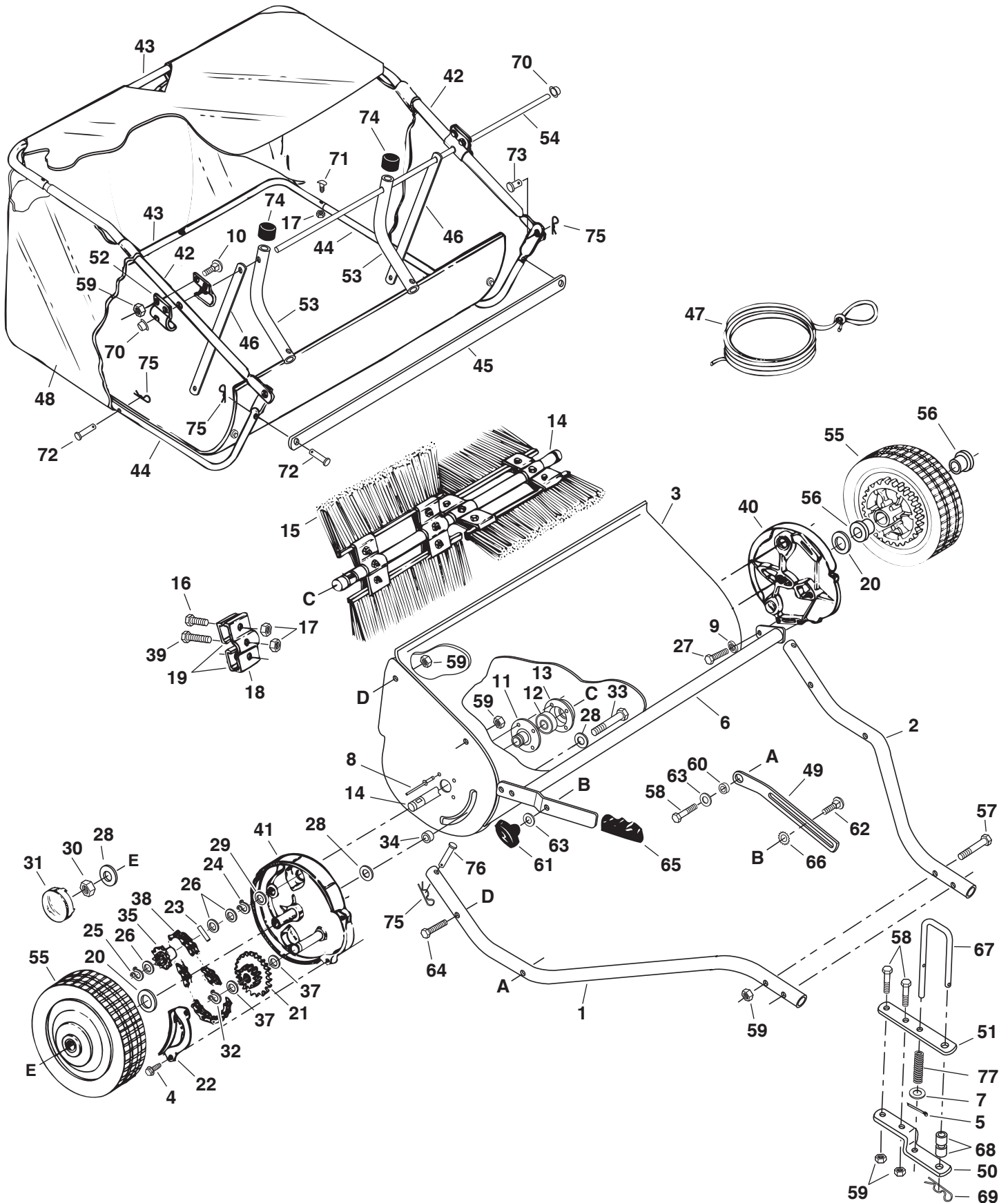

**REPAIR PARTS LIST FOR MODELS 486.242221, 486.242241
42" HIGH PERFORMANCE LAWSWEeper**

REF	PART NO.	QTY	DESCRIPTION	REF	PART NO.	QTY	DESCRIPTION
1	46776	1	Hitch Tube, R.H.	40	65667	1	Housing, Wheel Drive Ass'y. L.H.
2	46777	1	Hitch Tube, L.H.	41	65668	1	Housing, Wheel Drive Ass'y. R.H.
3	65885	1	Housing Assembly	42	49765	2	Tube, Upper Hopper Frame
4	49102	4	Screw, #12 x 1/2" Hex Head	43	47477	2	Tube, Rear Hopper Frame
5	142	1	Pin, Cotter 1/8" x 3/4" Lg.	44	48726	2	Tube, Lower Hopper Frame
6	68202	1	Height Adjustment Tube Ass'y.	45	24189	1	Strap, Bag Frame
7	43070	1	Washer, 3/8" Flat	46	25813	2	Strap, Hopper Support
8	C-9M5732	8	Rivet, Pop	47	43737	1	Hopper Rope
9	43086	4	Lock Washer, 5/16"	48	49768	1	Hopper Bag
10	43080	4	Bolt, Carriage 5/16-18 x 3/4"	49	24979	1	Strap, Height Adjustment
11	62489	2	Brush Bushing Ass'y.	50	23687	1	Bracket, Hitch
12	44232	2	Ball Bearing	51	24192	1	Bracket, Hitch (Straight)
13	1629-56	2	Retainer, Dust Cover	52	23331	4	Hopper Mount Clamp
14	25847	1	Brush Shaft	53	49766	2	Tube, Bag Arm
15	46780	4	Brush, 42"	54	46823	1	Pivot Rod, Hopper Bag
16	43012	8	Bolt, Hex 1/4-20 x 3/4" Lg.	55	44985	2	Wheel & Tire Ass'y. (with bearings)
17	47189	16	Nut, Nylock 1/4-20 Thread	56	45088	4	Wheel Bearing
18	23580	4	Retainer, Brush (Double)	57	46782	2	Bolt, Hex 5/16-18 x 3" Lg.
19	23581	8	Retainer, Brush (Single)	58	43224	3	Bolt, Hex 5/16-18 x 2-1/4" Lg.
20	44008	2	Washer, Flat 1-1/8" x .78" x .025"	59	47810	12	Nut, Nylock 5/16-18 Thread
21	62490	2	Sprocket / Gear	60	23625	1	Spacer, .38" x .62" x .27" L
22	23573	2	Dust Cover	61	43720	1	Knob, Wing 5/16-18 Thread
23	47046	2	Dowel Pin (Drive)	62	44326	1	Bolt, Carriage 5/16-18 x 1" Lg.
24	43655	2	Ring, Retaining 3/4"	63	43081	2	Washer, Flat 5/16" Std. Wrt.
25	716-0106	2	Ring, Retaining .594"	64	43084	3	Bolt, Hex 5/16-18 x 1-3/4" Lg.
26	40001	14	Washer, Shim 1-1/8" x .594" x .025"	65	43943	1	Grip, Height Adjust
27	43182	4	Bolt, Hex 5/16-18 x 3/4" Lg.	66	44732	1	Washer, Tooth Lock 5/16"
28	141	6	Washer, Flat 1-1/2" x .375" x .062"	67	49493	1	Pin, Hitch
29	1540-31	4	Washer, Flat .78" x 1.25" x .06"	68	23368	2	Tube, Hitch Spacer
30	1038	2	Nut, Nylock 3/8-24 Thread	69	43343	1	Hairpin Cotter, 1/8"
31	2674-32	2	Hub Cap	70	44917	2	Palnut, 3/8"
32	1650-1	2	Ring, Retaining (E-type)	71	43978	4	Curved Head Bolt, 1/4-20 x 1"
33	43932	2	Bolt, Hex 3/8-24 x 3-1/2" Lg.	72	48365	4	Pin, Clevis 1/4" x 1-1/8"
34	23400	2	Bushing, Spacer	73	48366	2	Pin, Clevis 3/8" x 1/2"
35	43890	1	Sprocket, Ratchet R.H.	74	44481	2	Cap, Vinyl
36	43889	1	Sprocket, Ratchet L.H. (not shown)	75	43055	8	Hairpin Cotter, 3/32" #3
37	44137	4	Washer, 1/2" x 1" x .02"	76	46867	2	Pin, Clevis 1/4" x 1-1/2" Lg.
38	44542	2	Chain, Roller	77	44230	1	Spring, Hitch Pin
39	43661	4	Bolt, Hex 1/4-20 x 1" Lg.		40734	1	Owners Manual

Get it fixed, at your home or ours!

Your Home

For expert troubleshooting and home solutions advice:

manage my home

www.managemyhome.com

For repair – **in your home** – of **all** major brand appliances, lawn and garden equipment, or heating and cooling systems, **no matter who made it, no matter who sold it!**

For the replacement parts, accessories and owner's manuals that you need to do-it-yourself.

For Sears professional installation of home appliances and items like garage door openers and water heaters.

1-800-4-MY-HOME[®] (1-800-469-4663)

Call anytime, day or night (U.S.A. and Canada)

www.sears.com www.sears.ca

Our Home

For repair of carry-in items like vacuums, lawn equipment, and electronics, call anytime for the location of your nearest

Sears Parts & Repair Service Center

1-800-488-1222 (U.S.A.) **1-800-469-4663** (Canada)

www.sears.com www.sears.ca

To purchase a protection agreement on a product serviced by Sears:

1-800-827-6655 (U.S.A.) **1-800-361-6665** (Canada)

Para pedir servicio de reparación a domicilio, y para ordenar piezas:

1-888-SU-HOGAR[®]

(1-888-784-6427)

Au Canada pour service en français:

1-800-LE-FOYER^{MC}

(1-800-533-6937)

www.sears.ca



® Registered Trademark / TM Trademark / SM Service Mark of Sears Brands, LLC

® Marca Registrada / TM Marca de Fábrica / SM Marca de Servicio de Sears Brands, LLC

^{MC} Marque de commerce / ^{MD} Marque déposée de Sears Brands, LLC

© Sears Brands, LLC

Free Manuals Download Website

<http://myh66.com>

<http://usermanuals.us>

<http://www.somanuals.com>

<http://www.4manuals.cc>

<http://www.manual-lib.com>

<http://www.404manual.com>

<http://www.luxmanual.com>

<http://aubethermostatmanual.com>

Golf course search by state

<http://golfingnear.com>

Email search by domain

<http://emailbydomain.com>

Auto manuals search

<http://auto.somanuals.com>

TV manuals search

<http://tv.somanuals.com>