

Owner's Manual



**6.0 HP
26 INCH TINE WIDTH
FRONT TINE TILLER
WITH REVERSE**

Model No.
917.292490

- Safety
- Assembly
- Operation
- Maintenance
- Español
- Repair Parts

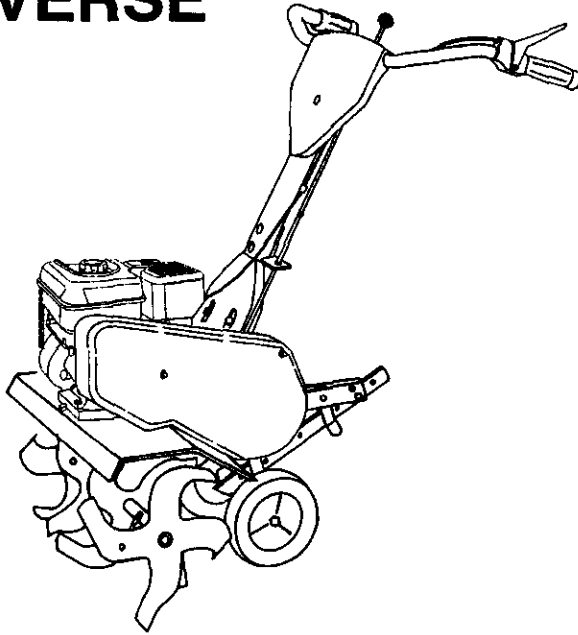

This product has a low emission engine which operates differently from previously built engines. Before you start the engine, read and understand this Owner's Manual.

CAUTION:

Read and follow all Safety Rules and Instructions before operating this equipment.

Sears, Roebuck and Co., Hoffman Estates, IL 60179
Visit our Craftsman website: www.sears.com/craftsman

TABLE OF CONTENTS

Warranty	2	Maintenance Schedule	11
Safety Rules	2	Service and Adjustments	13
Product Specifications	4	Storage	16
Assembly	6	Troubleshooting	17
Operation	7	Illustrated Parts List	38
Maintenance	11	Parts Ordering	Back Cover

WARRANTY

LIMITED TWO YEAR WARRANTY ON CRAFTSMAN TILLER

For two (2) years from date of purchase, when this Craftsman Tiller is maintained, lubricated, and tuned up according to the operating and maintenance instructions in the owner's manual, Sears will repair free of charge any defect in material or workmanship.

This Warranty does not cover:

- Expendable items which become worn during normal use, such as tines, spark plugs, air cleaners and belts.
- Repairs necessary because of operator abuse or negligence, including bent crankshafts and the failure to maintain the equipment according to the instructions contained in the owner's manual.
- If this Craftsman Tiller is used for commercial or rental purposes, this Warranty applies for only thirty (30) days from the date of purchase.

Warranty service is available by returning the craftsman power mower to the nearest sears service center/department in the united states. This warranty applies only while this product is in use in the united states.

This Warranty gives you specific legal rights, and you may also have other rights which vary from state to state.

SEARS, ROEBUCK AND CO., D/817WA, HOFFMAN ESTATES, IL 60179

SAFETY RULES

IMPORTANT: This cutting machine is capable of amputating hands and feet and throwing objects. Failure to observe the following safety instructions could result in serious injury or death.

TRAINING

- Read the Owner's Manual carefully. Be thoroughly familiar with the controls and the proper use of the equipment. Know how to stop the unit and disengage the controls quickly.
- Never allow children to operate the equipment. Never allow adults to operate the equipment without proper instruction.
- Keep the area of operation clear of all persons, particularly small children, and pets.

PREPARATION

- Thoroughly inspect the area where the equipment is to be used and remove all foreign objects.

- Disengage all clutches and shift into neutral before starting the engine (motor).
- Do not operate the equipment without wearing adequate outer garments. Wear footwear that will improve footing on slippery surfaces.
- Handle fuel with care; it is highly flammable.
- Use an approved fuel container.
- Never add fuel to a running engine or hot engine.
- Fill fuel tank outdoors with extreme care. Never fill fuel tank indoors.
- Replace gasoline cap securely and clean up spilled fuel before restarting.

SAFETY RULES

- Use extension cords and receptacles as specified by the manufacturer for all units with electric drive motors or electric starting motors.
- Never attempt to make any adjustments while the engine (motor) is running (except where specifically recommended by manufacturer).

OPERATION

- Do not put hands or feet near or under rotating parts.
- Exercise extreme caution when operating on or crossing gravel drives, walks, or roads. Stay alert for hidden hazards or traffic. Do not carry passengers.
- After striking a foreign object, stop the engine (motor), remove the wire from the spark plug, thoroughly inspect the tiller for any damage, and repair the damage before restarting and operating the tiller.
- Exercise caution to avoid slipping or falling.
- If the unit should start to vibrate abnormally, stop the engine (motor) and check immediately for the cause. Vibration is generally a warning of trouble.
- Stop the engine (motor) when leaving the operating position.
- Take all possible precautions when leaving the machine unattended. Disengage the tines, shift into neutral, and stop the engine.
- Before cleaning, repairing, or inspecting, shut off the engine and make certain all moving parts have stopped. Disconnect the spark plug wire, and keep the wire away from the plug to prevent accidental starting. Disconnect the cord on electric motors.
- Do not run the engine indoors; exhaust fumes are dangerous.
- Never operate the tiller without proper guards, plates, or other safety protective devices in place.
- Keep children and pets away.

- Do not overload the machine capacity by attempting to till too deep at too fast a rate.
- Never operate the machine at high speeds on slippery surfaces. Look behind and use care when backing.
- Never allow bystanders near the unit.
- Use only attachments and accessories approved by the manufacturer of the tiller.
- Never operate the tiller without good visibility or light.
- Be careful when tilling in hard ground. The tines may catch in the ground and propel the tiller forward. If this occurs, let go of the handlebars and do not restrain the machine.

MAINTENANCE AND STORAGE

- Keep machine, attachments, and accessories in safe working condition.
- Check shear pins, engine mounting bolts, and other bolts at frequent intervals for proper tightness to be sure the equipment is in safe working condition.
- Never store the machine with fuel in the fuel tank inside a building where ignition sources are present, such as hot water and space heaters, clothes dryers, and the like. Allow the engine to cool before storing in any enclosure.
- Always refer to the operator's guide instructions for important details if the tiller is to be stored for an extended period.

⚠Look for this symbol to point out important safety precautions. It means **CAUTION!!! BECOME ALERT!!! YOUR SAFETY IS INVOLVED.**

⚠CAUTION: Always disconnect spark plug wire and place wire where it cannot contact spark plug in order to prevent accidental starting when setting up, transporting, adjusting or making repairs.

⚠WARNING: Engine exhaust, some of its constituents, and certain vehicle components contain or emit chemicals known to the State of California to cause cancer and birth defects or other reproductive harm.

PRODUCT SPECIFICATIONS

GASOLINE CAPACITY:	3 QUARTS UNLEADED REGULAR
OIL (API-SF-SJ): (CAPACITY: 20 OZ.)	SAE 30 (ABOVE 32°F) SAE 5W-30 (BELOW 32°F)
SPARK PLUG : (GAP: .030")	CHAMPION RJ19LM OR J19LM

CONGRATULATIONS on your purchase of a Sears Tiller. It has been designed, engineered and manufactured to give you the best possible dependability and performance.

Should you experience any problems you cannot easily remedy, please contact a Sears or other qualified Service Center. We have competent, well-trained technicians and the proper tools to service or repair this unit.

Please read and retain this manual. The instructions will enable you to assemble and maintain your tiller properly. Always observe the "SAFETY RULES".

Your new tiller has been assembled at the factory with exception of those parts left unassembled for shipping purposes. To ensure safe and proper operation of your tiller all parts and hardware you assemble must be tightened securely. Use the correct tools as necessary to insure proper tightness.

CUSTOMER RESPONSIBILITIES

- Read and observe the safety rules.
- Follow a regular schedule in maintaining, caring for and using your tiller.
- Follow the instructions under the "Customer Responsibilities" and "Storage" sections of this Owner's Manual.







⚠ WARNING: This unit is equipped with an internal combustion engine and should not be used on or near any unimproved forest-covered, brush-covered or grass covered land unless the engine's exhaust system is equipped with a spark arrester meeting applicable local or state laws (if any). If a spark arrester is used, it should be maintained in effective working order by the operator.

In the state of California the above is required by law (Section 4442 of the California Public Resources Code). Other states may have similar laws. Federal laws apply on federal lands. A spark arrester for the muffler is available through your nearest Sears service center (See REPAIR PARTS section of this manual).





ACCESSORIES

These accessories were available when the tiller was purchased. They are also available at most Sears Retail outlets and Service Centers. Most Sears Stores can order repair parts for you when you provide the model number of your tiller.

ENGINE

SPARK PLUG	MUFFLER	AIR FILTER	GAS CAN	ENGINE OIL	STABILIZER
					

TILLER MAINTENANCE

BELT	TINES	SHEAR PIN	HAIRPIN CLIP
			

BAG OF PARTS

Your new tiller has been assembled at the factory with exception of those parts left unassembled for shipping purposes. To ensure safe and proper operation of your tiller all parts and hardware you assemble must be tightened securely. Use the correct tools as necessary to insure proper tightness.

TOOLS REQUIRED FOR ASSEMBLY

A socket wrench set will make assembly easier. Standard wrench sizes are listed.

- (1) Utility knife
- (1) Screwdriver
- (1) Pair of pliers
- (2) 1/2" wrenches

OPERATOR'S POSITION

When right or left hand is mentioned in this manual, it means when you are in the operating position (standing behind tiller handles).

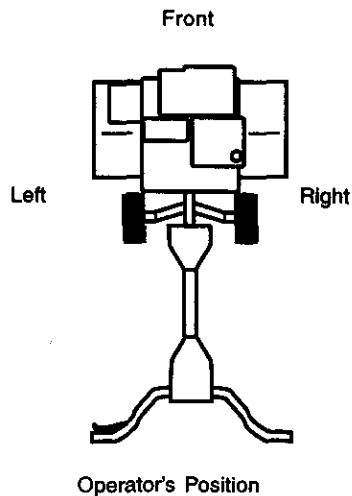

CONTENTS OF HARDWARE PACK

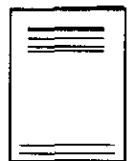

(1) Manual

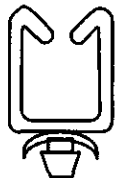

(1) Plastic Cable Clip

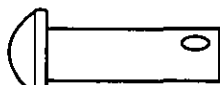

(1) Clevis Pin



(1) Washer
9/32 x 1/2 x
14 Gauge

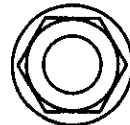

(2) Flange
Locknuts
5/16-18 UNC

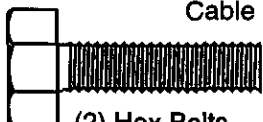

(2) Hex Bolts
5/16-18 x 1-1/4

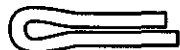

(1) Cotter Pin



(2) Hex Nuts
5/16-18

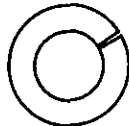

(2) Lock
Washers
5/16



(1) Bottle
Engine Oil

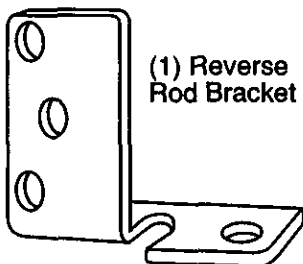

(1) Reverse
Rod Bracket



(1) Bushing

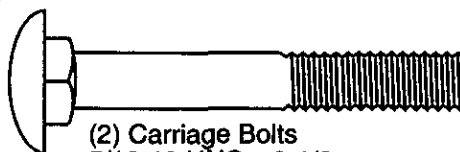

(2) Carriage Bolts
5/16-18 UNC x 2-1/2

ASSEMBLY

UNPACK CARTON

CAUTION: Be careful of exposed staples when handling or disposing of cartoning material.

IMPORTANT: When unpacking and assembling tiller, be careful not to stretch or kink cable(s).

1. Cut cable ties securing handle column and reverse rod.
2. Slide handle column onto handle mount.

3. Remove all packing from carton.

ASSEMBLE HANDLE

1. Slide reverse rod through hole in reverse rod bracket as shown.
2. Slide bushing over lower reverse rod and snap into bracket hole.

NOTE: Make sure tine control cable is routed in front of reverse rod bracket.

3. Attach reverse rod bracket to handle column using two (2) carriage bolts and two (2) flange locknuts and tighten securely.
4. Cut away carton.
5. Insert plastic cable clip into hole in handle column.
6. Route tine control cable through plastic cable clip on handle column.
7. Cut cable ties securing tiller to skid. Remove tiller from skid by pulling backwards.

ASSEMBLE REVERSE ROD

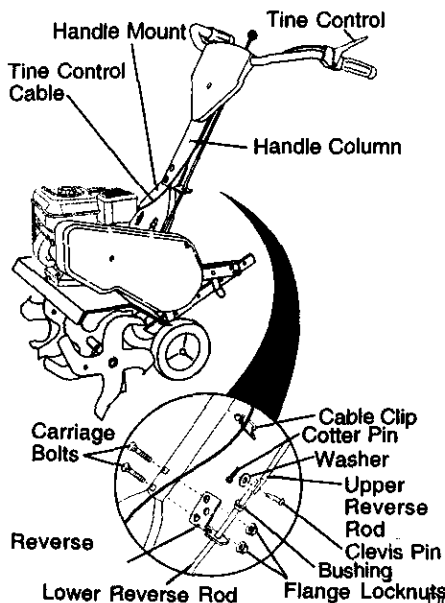

- Secure upper reverse rod to lower reverse rod using clevis pin, washer and cotter pin.

INSTALL DEPTH STAKE ASSEMBLY

1. Loosen nut "A".
2. Insert stake support between engine bracket halves with stake spring down.
3. Bolt stake support to engine brackets with bolts, lock washers and nuts. Tighten securely. Tighten nut "A".
4. Depth stake must move freely. If it does not, loosen support bolt.

HANDLE HEIGHT

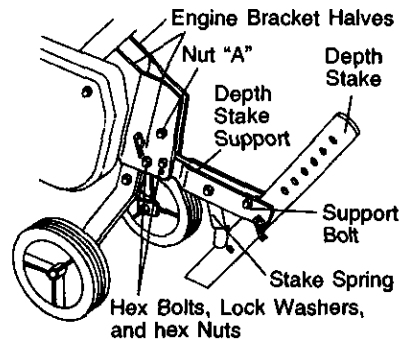

- Handle height may be adjusted to better suit operator. (See "HANDLE HEIGHT" in the Service and Adjustments section of this manual).

TILLING WIDTH

- Tilling width may be adjusted to better handle your tilling conditions (See "TINE ARRANGEMENT" in the Service and Adjustments section of this manual).

TINE OPERATION

- Check tine operation before first use. (See "TINE OPERATION CHECK" in the Service and Adjustments section of this manual).

OPERATION

KNOW YOUR TILLER

READ THIS OWNER'S MANUAL AND SAFETY RULES BEFORE OPERATING YOUR TILLER.

Compare the illustrations with your tiller to familiarize yourself with the location of various controls and adjustments. Save this manual for future reference.

These symbols may appear on your Tiller or in literature supplied with the product. Learn and understand their meaning.

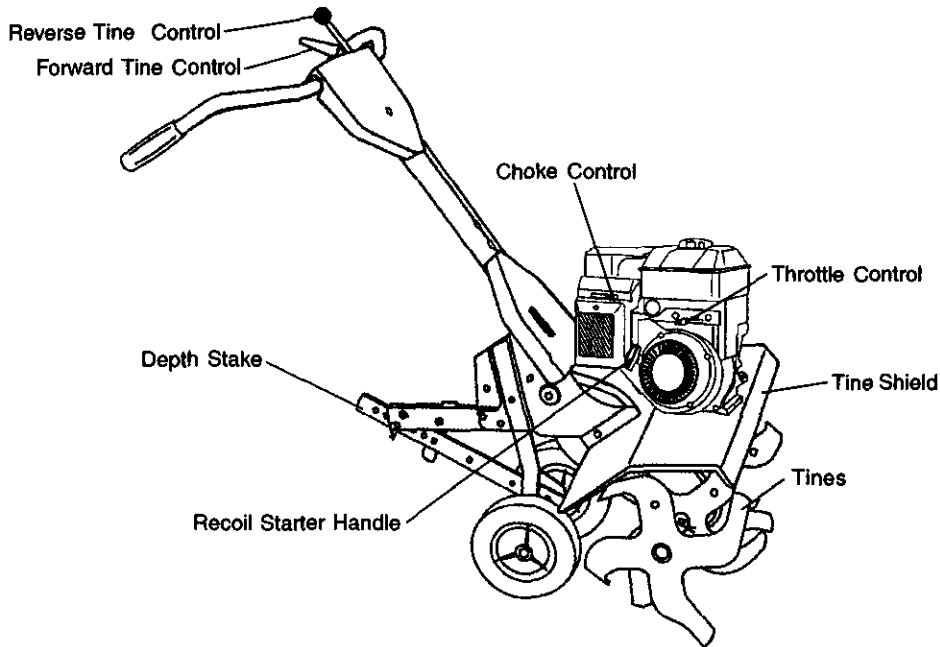
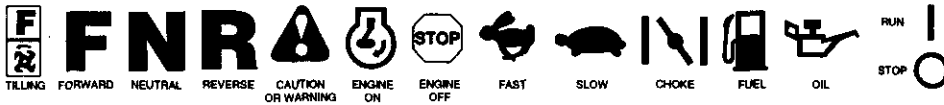

Sears tillers conform to the safety standards of the American National Standards Institute.

FORWARD TINE CONTROL - Engages tines in forward direction.

REVERSE TINE CONTROL - Engages tines in reverse direction.

CHOKE CONTROL - Used when starting a cold engine.

THROTTLE CONTROL - Controls engine speed.

DEPTH STAKE - Controls forward speed and the depth at which the tiller will dig.

RECOIL STARTER HANDLE - Used to start the engine.

OPERATION



The operation of any tiller can result in foreign objects thrown into the eyes, which can result in severe eye damage. Always wear safety glasses or eye shields before starting your tiller and while tilling. We recommend a wide vision safety mask over spectacles or standard safety glasses.

HOW TO USE YOUR TILLER

Know how to operate all controls before adding fuel and oil or attempting to start engine.

STOPPING

TINES

1. Release forward tine control to stop forward movement.
2. Release reverse tine control to stop reverse movement.

ENGINE

- Move throttle control to "STOP" position.

NOTE: Never use choke to stop engine.

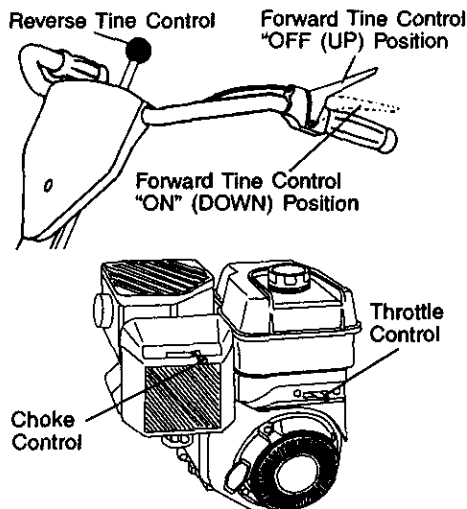

TINE OPERATION

FORWARD

- Squeeze forward tine control to handle.

REVERSE

- With forward tine control "OFF" (up) position, pull back and hold reverse tine control.

TILLING

The speed and depth of tilling is regulated by the position of the depth stake and wheel height.

The depth stake should always be below the wheels for digging. It serves as a brake to slow the tiller's forward motion to enable the tines to penetrate the ground. Also, the more the depth stake is lowered into the ground the deeper the tines will dig.

DEPTH STAKE

Adjust depth stake by removing the hairpin clip and clevis pin. Change depth stake to desired position. Replace the clevis pin and hairpin clip.

- For normal tilling, set depth stake at the second or third hole from the top.

WHEELS

Adjust wheels by removing the hairpin clip and clevis pin. Change wheel position. Replace the hairpin clip and clevis pin.

- For normal tilling, set wheels at the second or third hole from the top.

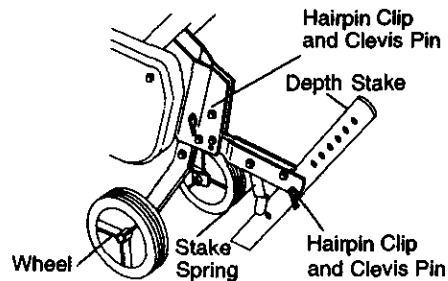

TOTRANSPORT

CAUTION: Before lifting or transporting, allow tiller engine and muffler to cool. Disconnect spark plug wire. Drain gasoline from fuel tank.

AROUND THE YARD

1. Tip depth stake forward until it is held by the stake spring.
2. Push tiller handles down, raising tines off the ground.
3. Push or pull tiller to desired location.

AROUND TOWN

1. Disconnect spark plug wire.
2. Drain fuel tank.
3. Transport in upright position to prevent oil leakage.

BEFORE STARTING ENGINE

IMPORTANT: Be very careful not to allow dirt to enter the engine when checking or adding oil or fuel. Use clean oil and fuel and store in approved, clean, covered containers. Use clean fill funnels.

FILL ENGINE WITH OIL

1. Remove hangtag from engine.
 2. With engine level, remove engine oil filler plug.
 3. Fill engine with oil to point of overflowing. For approximate capacity see "PRODUCT SPECIFICATIONS" on page 4 of this manual. All oil must meet A.P.I. Service Classification SF-SJ.
 4. Tilt tiller back on its wheels and then re-level.
 5. With engine level, refill to point of overflowing if necessary. Replace oil filler plug.
- For cold weather operation you should change oil for easier starting (See "OIL VISCOSITY CHART" in the Maintenance section of this manual).
 - To change engine oil, see the Maintenance section of this manual.

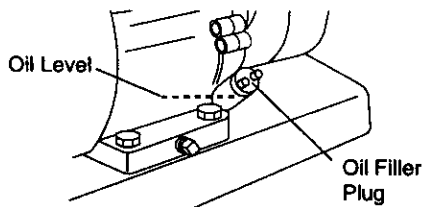

ADD GASOLINE

- Fill fuel tank. Use fresh, clean, regular unleaded gasoline. (Use of leaded gasoline will increase carbon and lead oxide deposits and reduce valve life.)

IMPORTANT: When operating in temperatures below 32°F(0°C), use fresh, clean, winter grade gasoline to help insure good cold weather starting.

WARNING: Experience indicates that alcohol blended fuels (called gasohol or using ethanol or methanol) can attract moisture which leads to separation and formation of acids during storage. Acidic gas can damage the fuel system of an engine while in storage. **To avoid engine problems, the fuel system should be emptied before storage of 30 days or longer.** Drain the gas tank, start the engine and let it run until the fuel lines and carburetor are empty. **Use fresh fuel next season.** See Storage section of this manual for additional information. Never

use engine or carburetor cleaner products in the fuel tank or permanent damage may occur.

CAUTION: Fill to within 1/2 inch of top of fuel tank to prevent spills and to allow for fuel expansion. If gasoline is accidentally spilled, move machine away from area of spill. Avoid creating any source of ignition until gasoline vapors have disappeared.

Do not overfill. Wipe off any spilled oil or fuel. Do not store, spill or use gasoline near an open flame.

TO START ENGINE

CAUTION: Keep drive control bar in "DISENGAGED" position when starting engine.

When starting engine for the first time or if engine has run out of fuel, it will take extra pulls of the recoil starter to move fuel from the tank to the engine.

1. Make sure spark plug wire is properly connected.
2. Place throttle control in "FAST" position.
3. Move choke control to choke position.
4. Grasp recoil starter handle with one hand and grasp tiller handle with other hand. Pull rope out slowly until engine reaches start of compression cycle (rope will pull slightly harder at this point).
5. Pull recoil starter handle quickly. Do not let starter handle snap back against starter.

NOTE: If engine fires but does not start, move choke control to half choke position. Pull recoil starter handle until engine starts.

6. When engine starts, slowly move choke control to "RUN" position as engine warms up.

NOTE: A warm engine requires less choking to start.

7. Move throttle control to desired running position.
8. Allow engine to warm up for a few minutes before engaging tines.

NOTE: If at a high altitude (3000 feet) or in cold temperatures (below 32°F), the carburetor fuel mixture may need to be adjusted for best engine performance. See "TO ADJUST CARBURETOR" in the Service and Adjustments section of this manual.

NOTE: If engine does not start, see troubleshooting points.

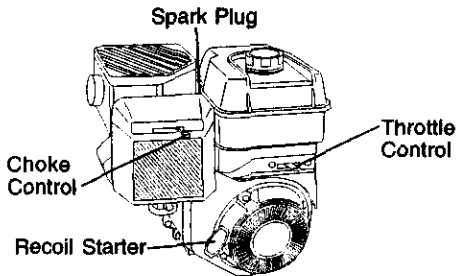

BREAKING IN YOUR TILLER

Break-in your belt(s), pulleys and tine control before you actually begin tilling.

- Start engine, tip tines off ground by pressing handles down and engage tine control to start tine rotation. Allow tines to rotate for five minutes.
- Check tine operation and adjust if necessary. See "TINE OPERATION CHECK" in the Service and Adjustments section of this manual.

TILLING HINTS

CAUTION: Until you are accustomed to handling your tiller, start actual field use with throttle in slow position (mid-way between "FAST" and "IDLE").

To help tiller move forward, lift up the handles slightly (thus lifting depth stake out of ground). To slow down the tiller, press down on handles.

If you are straining or tiller is shaking, the wheels and depth stake are not set properly in the soil being tilled. The proper setting of the wheels and depth stake is through trial and error and depends upon the soil condition. (The harder or wetter the ground, the slower the engine and tine speed needed. Under these poor conditions, at fast speed the tiller will run and jump over the ground). A properly adjusted tiller will dig with little effort from the operator.

- Tilling is digging into, turning over, and breaking up packed soil before planting. Loose, unpacked soil helps root growth. Best tilling depth is 4" to 6". A tiller will also clear the soil of unwanted vegetation. The decomposition of this vegetable matter enriches the soil. Depending on the climate (rainfall and wind), it may be advisable to till the soil at the end of the growing season to further condition the soil.

- Soil conditions are important for proper tilling. Tines will not readily penetrate dry, hard soil which may contribute to excessive bounce and difficult handling of your tiller. Hard soil should be moistened before tilling; however, extremely wet soil will "ball-up" or clump during tilling. Wait until the soil is less wet in order to achieve the best results. When tilling in the fall, remove vines and long grass to prevent them from wrapping around the tine shaft and slowing your tilling operation.
- You will find tilling much easier if you leave a row untilled between passes. Then go back between tilled rows. There are two reasons for doing this. First, wide turns are much easier to negotiate than about-faces. Second, the tiller won't be pulling itself, and you, toward the row next to it.
- Set depth stake and wheel height for shallow tilling when working extremely hard soil or sod. Then work across the first cuts at normal depth.

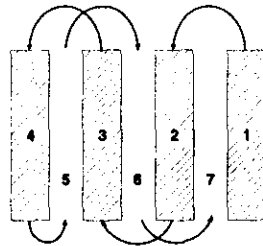

CULTIVATING

Cultivating is destroying the weeds between rows to prevent them from robbing nourishment and moisture from the plants. At the same time, breaking up the upper layer of soil crust will help retain moisture in the soil. Best digging depth is 1" to 3".

- You will probably not need to use the depth stake. Begin by tipping the depth stake forward until it is held by the stake spring.
- Cultivate up and down the rows at a speed which will allow tines to uproot weeds and leave the ground in rough condition, promoting no further growth of weeds and grass.

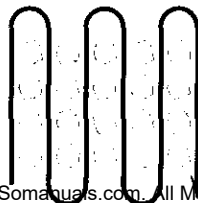

MAINTENANCE

MAINTENANCE SCHEDULE	SERVICE DATES			
FILL IN DATES AS YOU COMPLETE REGULAR SERVICE	BEFORE EACH USE	EVERY 5 HOURS	EVERY 25 HOURS	EVERY 50 HOURS
Check Engine Oil Level	✓	✓		
Change Engine Oil			✓ _{1,2}	
Oil Pivot Points		✓		
Inspect Spark Arrestor / Muffler			✓	
Inspect Air Screen	✓			
Clean or Replace Air Cleaner Cartridge			✓ ₂	
Clean Engine Cylinder Fins			✓	
Replace Spark Plug			✓	

1 - Change more often when operating under a heavy load or in high ambient temperatures.
 2 - Service more often when operating in dirty or dusty conditions.

GENERAL RECOMMENDATIONS

The warranty on this tiller does not cover items that have been subjected to operator abuse or negligence. To receive full value from the warranty, the operator must maintain tiller as instructed in this manual.

Some adjustments will need to be made periodically to properly maintain your tiller.

All adjustments in the Service and Adjustments section of this manual should be checked at least once each season.

- Once a year you should replace the spark plug, clean or replace air filter, and check tines and belts for wear. A new spark plug and clean air filter assure proper air-fuel mixture and help your engine run better and last longer.

BEFORE EACH USE

1. Check engine oil level.
2. Check tine operation.
3. Check for loose fasteners.

LUBRICATION

Keep unit well lubricated (See "LUBRICATION CHART").

LUBRICATION CHART

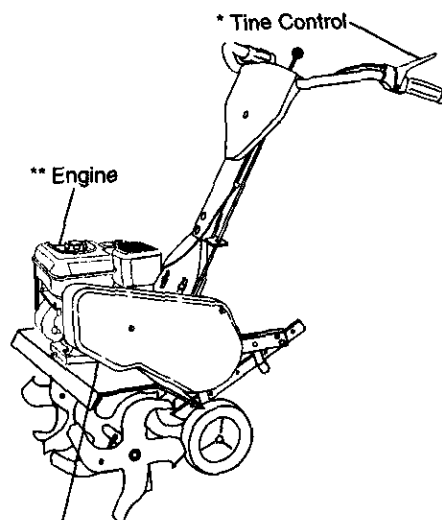

* SAE 30 OR 10W30 MOTOR OIL
 ** REFER TO MAINTENANCE "ENGINE" SECTION.

CAUTION: Disconnect spark plug wire before performing any maintenance (except carburetor adjustment) to prevent accidental starting of engine. Prevent fires! Keep the engine free of grass, leaves, spilled oil, or fuel. Remove fuel from tank before tipping unit for maintenance. Clean muffler area of all grass, dirt, and debris. Do not touch hot muffler or cylinder fins as contact may cause burns.

ENGINE LUBRICATION

Use only high quality detergent oil rated with API service classification SF-SJ. Select the oil's SAE viscosity grade according to your expected temperature.

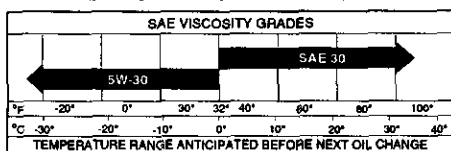

NOTE: Although multi-viscosity oils (5W-30, 10W-30, etc.) improve starting in cold weather, these multi-viscosity oils will result in increased oil consumption when used above 32°F (0°C). Check your engine oil level more frequently to avoid possible engine damage from running low on oil.

Change the oil after every 50 hours of operation or at least once a year if the tiller is not used for 50 hours in one year. Check the crankcase oil level before starting the engine and after each five (5) hours of continuous use. Add SAE 30 motor oil or equivalent. Tighten oil filler plug securely each time you check the oil level.

TO CHANGE ENGINE OIL

Determine temperature range expected before oil change. All oil must meet API service classification SF-SJ.

- Be sure tiller is on level surface.
 - Oil will drain more freely when warm.
 - Catch oil in a suitable container.
1. Remove drain plug.
 2. Tip tiller forward to drain oil.
 3. After oil has drained completely, replace oil drain plug and tighten securely.
 4. Remove oil filler plug. Be careful not to allow dirt to enter the engine.
 5. Refill engine with oil. See "FILL ENGINE WITH OIL" in the Operation section of this manual.

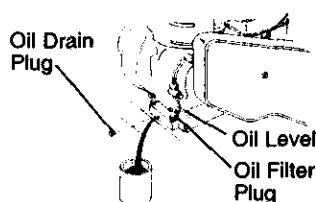

AIR CLEANER

Service air cleaner cartridge every twenty-five hours, more often if engine is used in very dusty conditions.

1. Loosen air cleaner screw.
2. Remove air cleaner cover.
3. Carefully remove air cleaner cartridge. Be careful. Do not allow dirt or debris to fall into carburetor.
4. Clean by tapping gently on a flat surface.

NOTE: If very dirty or damaged, replace cartridge.

5. Clean and replace cover. Tighten screw securely.

CAUTION: Petroleum solvents, such as kerosene, are not to be used to clean cartridge. They may cause deterioration of the cartridge. Do not oil cartridge. Do not use pressurized air to clean or dry cartridge.

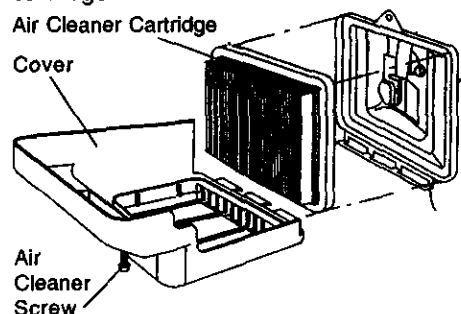

COOLING SYSTEM

Your engine is air cooled. For proper engine performance and long life keep your engine clean.

- Clean air screen frequently using a stiff-bristled brush.
- Remove blower housing and clean as necessary.
- Keep cylinder fins free of dirt and chaff.

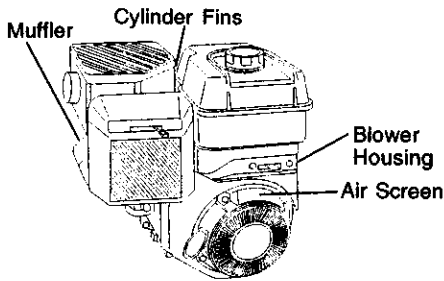

MUFFLER

Do not operate tiller without muffler. Do not tamper with exhaust system. Damaged mufflers or spark arresters could create a fire hazard. Inspect periodically and replace if necessary. If your engine is equipped with a spark arrester screen assembly, remove every 50 hours for cleaning and inspection. Replace if damaged.

SPARK PLUG

Replace spark plugs at the beginning of each tilling season or after every 50 hours of use, whichever comes first. Spark plug type and gap setting are shown in "PRODUCT SPECIFICATIONS" on page 4 of this manual.

TRANSMISSION

Your transmission is sealed and will not require lubrication unless serviced.

CLEANING

Do not clean your tiller when the engine and transmission are hot. We do not recommend using pressurized water (garden hose, etc.) to clean your unit unless the gasket area around the transmission and the engine muffler, air filter and carburetor are covered to keep water out. Water in engine will shorten the useful life of your tiller.

- Clean engine, wheels, finish, etc. of all foreign matter.
- Keep finished surfaces and wheels free of all gasoline, oil, etc.
- Protect painted surfaces with automotive type wax.

SERVICE AND ADJUSTMENTS

CAUTION: Disconnect spark plug wire from spark plug and place wire where it cannot come into contact with plug.

TILLER

TO ADJUST HANDLE HEIGHT

Factory assembly has provided lowest handle height. Select handle height best suited for your tilling conditions. Handle height will be different when tiller digs into soil.

1. If a higher handle height is desired, loosen the four nuts securing handle panel to engine brackets.
2. Slide handle panel to desired location.
3. Tighten the four nuts securely.

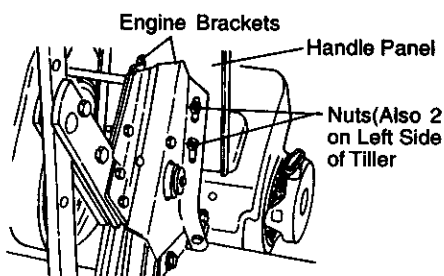

TINE ARRANGEMENT

Your outer tines can be assembled in several different ways to suit your tilling or cultivating needs.

CAUTION: Tines are sharp. Wear gloves or other protection when handling tines.

NORMAL TILLING - 26" PATH

- Assemble holes "A" in tine hubs to holes "B" in tine shaft.

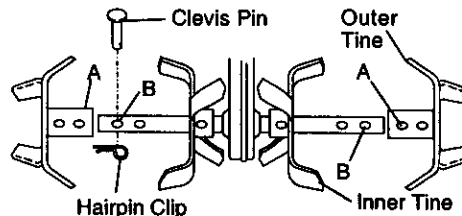

MID-WIDTH TILLING - 24" PATH

- Assemble holes "A" in tine hubs to holes "C" in tine shaft.

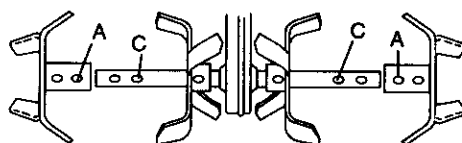

**NARROW TILLING/CULTIVATING -
12-3/4" PATH**

- Remove outer tines.

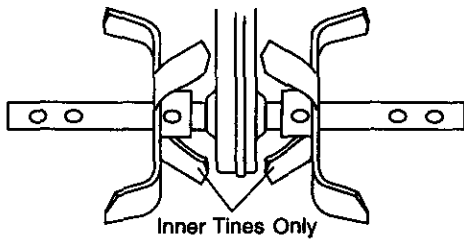

NOTE: When reassembling outer tines, be sure right tine assembly (marked "R") and left tine assembly (marked "L") are mounted to correct side of tine shaft.

TINE OPERATION CHECK

WARNING: Disconnect spark plug wire from spark plug to prevent starting while checking tine operation.

For proper tine operation, forward tine control lever must be against control body and all slack removed from inner wire of control cable when control is in the "OFF" (up) position.

If lever and cable are loose, loosen cable clip at lower end of cable. Pull up on cable to remove slack, without extending spring on end of cable, and retighten cable clip.

FINAL CHECK "OFF" POSITION

1. With tine control "OFF" (up), push down on handle to raise tines off the ground.
2. Slowly pull recoil starter handle while observing tines. Tines should not rotate.
3. If tines rotate, inner wire of control cable is too tight which is extending lower spring and engaging tines. Loosen cable clip and push down on cable only enough to relieve spring tension. Tighten cable clip.
4. Recheck in "OFF" position and adjust if necessary.

FINAL CHECK "ON" POSITION

5. With tine control "ON" (held down to handle) push down on handle to raise tines off the ground.
6. Slowly pull recoil starter handle while observing tines. Tines should rotate forward.
7. If tines do not rotate, inner wire of control cable is too loose. Loosen cable clip and pull cable up to remove slack and retighten clip.
8. Recheck in "ON" position and adjust if necessary.

NOTE: If "ON" position check required adjustment, recheck "OFF" position adjustment to insure tines do not rotate when control is "OFF" (up).

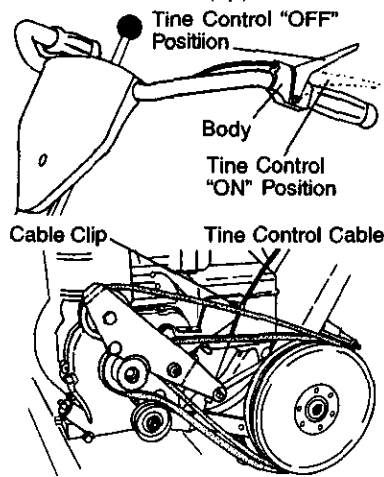

TO REMOVE BELT GUARD

1. Remove two (2) cap nuts and washers from side of belt guard.
2. Loosen (do not remove) tine shield nut on underside of tine shield.
3. Pull belt guard out and away from unit.
4. Replace belt guard by reversing above procedure. Be sure slot in bottom of belt guard is under head of tine shield bolt and all nuts are tightened securely.

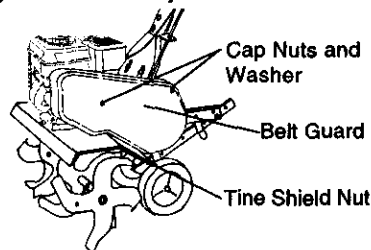

TO REPLACE V-BELTS

Replace V-belts if they have stretched considerably or if they show cracks or frayed edges. There are two (2) V-belts - forward (inside) and reverse (outside).

1. Belt guard must be removed to service belts. See "TO REMOVE BELT GUARD" in this section of manual.

NOTE: Observe carefully routing of both belts and location of all belt guides before removing belts.

BELT REMOVAL

2. Remove reverse idler pulley from idler

3. Remove reverse (outside) V-belt.
4. Remove forward (inside) V-belt from transmission pulley first and then from engine pulley.

BELT REPLACEMENT

5. Install new forward (inside) V-belt to engine pulley first then to transmission pulley. Be sure belt is positioned on inside groove of both pulleys, inside all belt guides and rests on idler pulley.
6. Before installing reverse (outside) V-belt, turn belt "inside out". Twist so wide, flat surface of belt is to inside.
7. Wrap V-belt around reverse idler pulley and reassemble idler to idler arm. Tighten securely. Be sure belt is between reverse idler pulley and idler arm pin.
8. Install belt to outside groove of transmission pulley. Be sure belt is inside all belt guides and rests on outside groove of engine pulley.

CHECK TINE OPERATION

9. See "TINE OPERATION CHECK" in this section of manual.
10. Replace belt guard.

FRONT VIEW REFERENCE

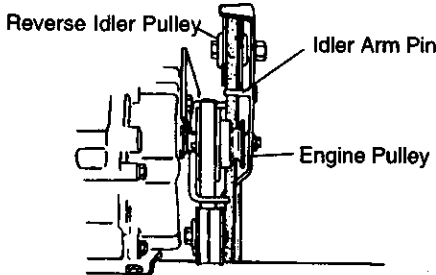

FORWARD MOTION (INSIDE) V-BELT

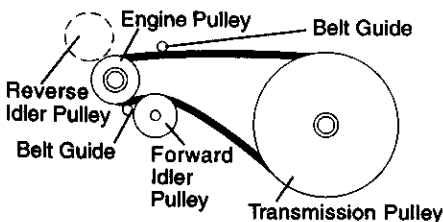

REVERSE (OUTSIDE) V-BELT

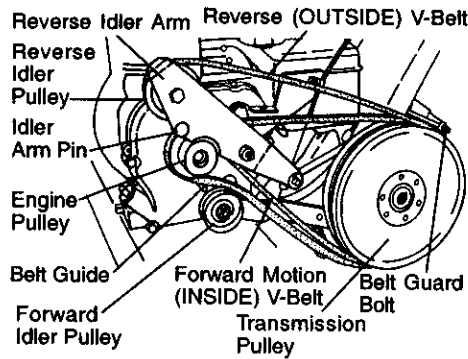
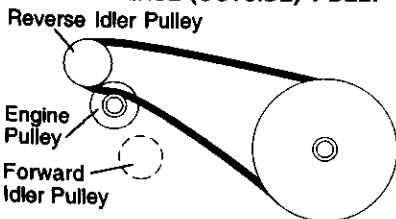

ENGINE

Maintenance, repair, or replacement of the emission control devices and systems, which are being done at the customer's expense, may be performed by any non-road engine repair establishment or individual. Warranty repairs must be performed by an authorized engine manufacturer's service outlet.

TO ADJUST CARBURETOR

The carburetor has been preset at the factory and adjustment should not be necessary. However, engine performance can be affected by differences in fuel, temperature, altitude or load. If the carburetor does need adjustment, contact your nearest authorized service center/department.

IMPORTANT: Never tamper with the engine governor, which is factory set for proper engine speed. Overspeeding the engine above the factory high speed setting can be dangerous. If you think the engine-governed high speed needs adjusting, contact your nearest sears or other qualified service center which has the proper equipment and experience to make any necessary adjustments.

STORAGE

Immediately prepare your tiller for storage at the end of the season or if the unit will not be used for 30 days or more.

CAUTION: Never store the tiller with gasoline in the tank inside a building where fumes may reach an open flame or spark. Allow the engine to cool before storing in any enclosure.

TILLER

1. Clean entire tiller (See "CLEANING" in the Maintenance section of this manual).
2. Inspect and replace belts, if necessary (See belt replacement instructions in the Service and Adjustments section of this manual).
3. Lubricate as shown in the Maintenance section of this manual.
4. Be sure that all nuts, bolts and screws are securely fastened. Inspect moving parts for damage, breakage and wear. Replace if necessary.
5. Touch up all rusted or chipped paint surfaces; sand lightly before painting.

ENGINE

FUEL SYSTEM

IMPORTANT: It is important to prevent gum deposits from forming in essential fuel system parts such as the carburetor, fuel filter, fuel hose, or tank during storage. Also, experience indicates that alcohol blended fuels (called gasohol or using ethanol or methanol) can attract moisture which leads to separation and formation of acids during storage. Acidic gas can damage the fuel system of an engine while in storage.

1. Drain the fuel tank.
 2. Start the engine and let it run until the fuel lines and carburetor are empty.
- Never use engine or carburetor cleaner products in the fuel tank or permanent damage may occur.
 - Use fresh fuel next season.

NOTE: Fuel stabilizer is an acceptable alternative in minimizing the formation of fuel gum deposits during storage. Add stabilizer to gasoline in fuel tank or storage container. Always follow the mix ratio found on stabilizer container. Run engine at least 10 minutes after adding stabilizer to allow the stabilizer to reach the carburetor. Do not drain the gas tank and carburetor if using fuel stabilizer.

ENGINE OIL

Drain oil (with engine warm) and replace with clean oil. (See "ENGINE" in the Maintenance section of this manual).

CYLINDER

1. Remove spark plug.
2. Pour 1 ounce (29 ml) of oil through spark plug hole into cylinder.
3. Pull starter handle slowly several times to distribute oil.
4. Replace with new spark plug.

OTHER

- Do not store gasoline from one season to another.
- Replace your gasoline can if your can starts to rust. Rust and/or dirt in your gasoline will cause problems.
- If possible, store your unit indoors and cover it to give protection from dust and dirt.
- Cover your unit with a suitable protective cover that does not retain moisture. Do not use plastic. Plastic cannot breathe which allows condensation to form and will cause your unit to rust.

IMPORTANT: Never cover tiller while engine and exhaust areas are still warm.

TROUBLESHOOTING

PROBLEM	CAUSE	CORRECTION
Will not start	<ol style="list-style-type: none"> 1. Out of fuel. 2. Engine not "CHOKED" properly. 3. Engine flooded. 4. Dirty air cleaner. 5. Water in fuel. 6. Clogged fuel tank. 7. Loose spark plug wire. 8. Bad spark plug or improper gap. 9. Carburetor out of adjustment. 10. Oil soaked air filter. 	<ol style="list-style-type: none"> 1. Fill fuel tank. 2. See "TO START ENGINE" in the Operation section. 3. Wait several minutes before attempting to start. 4. Clean or replace air cleaner cartridge. 5. Drain fuel tank and carburetor, and refill tank with fresh gasoline. 6. Remove fuel tank and clean. 7. Make sure spark plug wire is seated properly on plug. 8. Replace spark plug or adjust gap. 9. Make necessary adjustments. 10. Replace air filter.
Hard to start	<ol style="list-style-type: none"> 1. Throttle control not set properly. 2. Dirty air cleaner. 3. Bad spark plug or improper gap. 4. Stale or dirty fuel. 5. Loose spark plug wire. 6. Carburetor out of adjustment. 	<ol style="list-style-type: none"> 1. Place throttle control in "FAST" position. 2. Clean or replace air cleaner cartridge. 3. Replace spark plug or adjust gap. 4. Drain fuel tank and refill with fresh gasoline. 5. Make sure spark plug wire is seated properly on plug. 6. Make necessary adjustments.
Loss of power	<ol style="list-style-type: none"> 1. Engine is overloaded. 2. Dirty air cleaner. 3. Low oil level/dirty oil. 4. Faulty spark plug. 5. Oil in fuel. 6. Stale or dirty fuel. 7. Water in fuel. 8. Clogged fuel tank. 9. Spark plug wire loose. 10. Dirty engine air screen. 11. Dirty/clogged muffler. 12. Carburetor out of adjustment. 13. Poor compression. 	<ol style="list-style-type: none"> 1. Set depth stake and wheels for shallower tilling. 2. Clean or replace air cleaner cartridge. 3. Check oil level/change oil. 4. Clean and regap or change spark plug. 5. Drain and clean fuel tank and refill, and clean carburetor. 6. Drain fuel tank and refill with fresh gasoline. 7. Drain fuel tank and carburetor, and refill tank with fresh gasoline. 8. Remove fuel tank and clean. 9. Connect and tighten spark plug wire. 10. Clean engine air screen. 11. Clean/replace muffler. 12. Make necessary adjustments. 13. Contact a Sears or other qualified service center.

PROBLEM	CAUSE	CORRECTION
Engine overheats	<ol style="list-style-type: none"> 1. Low oil level/dirty oil. 2. Dirty engine air screen. 3. Dirty engine. 4. Partially plugged muffler. 5. Improper carburetor adjustment. 	<ol style="list-style-type: none"> 1. Check oil level/change oil. 2. Clean engine air screen. 3. Clean cylinder fins, air screen, muffler area. 4. Remove and clean muffler. 5. Adjust carburetor to richer position.
Excessive bounce/difficult handling	<ol style="list-style-type: none"> 1. Ground too dry and hard. 	<ol style="list-style-type: none"> 1. Moisten ground or wait for more favorable soil conditions.
Soil balls up or clumps	<ol style="list-style-type: none"> 1. Ground too wet. 	<ol style="list-style-type: none"> 1. Wait for more favorable soil conditions.
Engine runs but tiller won't move	<ol style="list-style-type: none"> 1. Tine control is not engaged. 2. V-belt not correctly adjusted. 3. V-belt is off pulley(s). 	<ol style="list-style-type: none"> 1. Engage tine control. 2. Inspect/adjust V-belt. 3. Inspect V-belt.
Engine runs but labors when tilling	<ol style="list-style-type: none"> 1. Tilling too deep. 2. Throttle control not properly adjusted. 3. Carburetor out of adjustment. 	<ol style="list-style-type: none"> 1. Set depth stake for shallower tilling. 2. Check throttle control setting. 3. Make necessary adjustments.
Tines Skip over ground	<ol style="list-style-type: none"> 1. Shear pin (s) broken. 	<ol style="list-style-type: none"> 1. Replace shear pin(s).
Hard to Shift into gear	<ol style="list-style-type: none"> 1. Gears not timed. 	<ol style="list-style-type: none"> 1. Briefly engage drive control bar and release or rock tiller forward and backward until are able to shift gears.
Tiller shuts off when drive control bar engaged	<ol style="list-style-type: none"> 1. Shift lever set in between counter rotating till position and forward rotating till position. 2. Tines jammed. 	<ol style="list-style-type: none"> 1. Shift to either counter rotating till position or forward rotating till position. 2. Clear tines.

REPAIR PARTS

TILLER -- MODEL NUMBER 917.292490

HANDLES

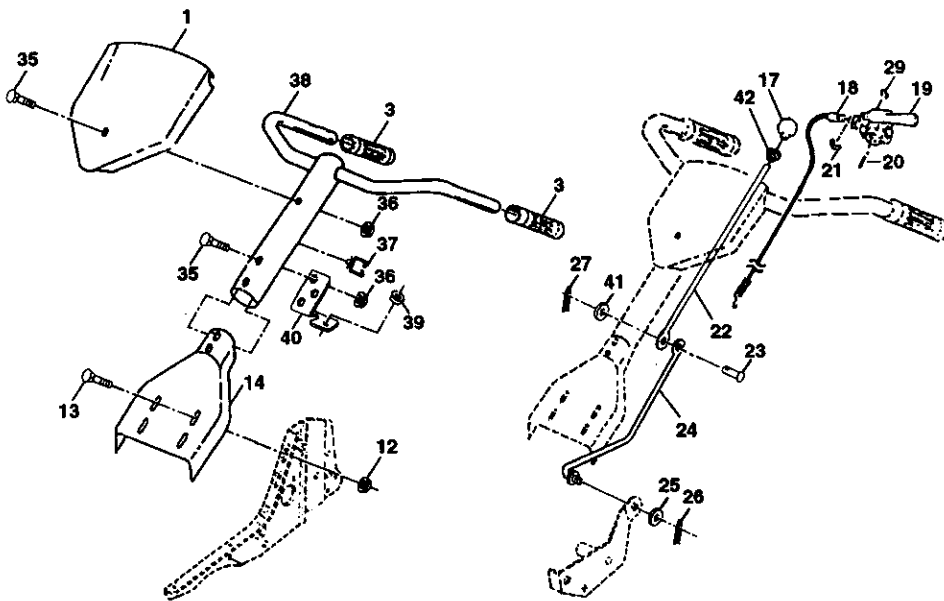

KEY PART NO.	NO.	DESCRIPTION
1	136993	Panel, Control
3	110632X	Grip, Handle
12	98000129	Nut, Flange
13	STD533107	Bolt, Carriage 5/16-18 x 3/4
14	110514X	Assembly, Panel and Tube
17	106932X	Knob, Control, Reverse
18	3066J	Cable, Tine Control
19	151229	Lever, Control, Tine
20	154805	Pin, Pivot
21	12000027	Ring, Clip
22	101248K	Reverse Rod, Upper
23	1778E	Pin, Retaining
24	137056	Reverse Rod, Lower
25	STD551037	Washer 13/32 x 13/16 x 16 Ga.

KEY PART NO.	NO.	DESCRIPTION
26	STD561210	Pin, Cotter 1/8 x 3/4
27	STD560907	Pin, Cotter 3/32 x 1/2
29	12000059	Retaining Ring
35	72010520	Bolt 5/16-18 X 2-1/2
36	73970500	Locknut, Flange 5/16-18 UNC
37	165197	Clip, Cable
38	152094	Assembly, Handle Column
39	137640	Bushing, Reverse Rod Bracket
40	136998	Bracket, Reverse Rod
41	STD551025	Washer 9/32 x 1/2 x 14 Gauge
42	139907	Grommet

NOTE: All component dimensions given in U.S. inches.
1 inch = 25.4 mm

TILLER -- MODEL NUMBER 917.292490
BELT GUARD AND PULLEY ASSEMBLY

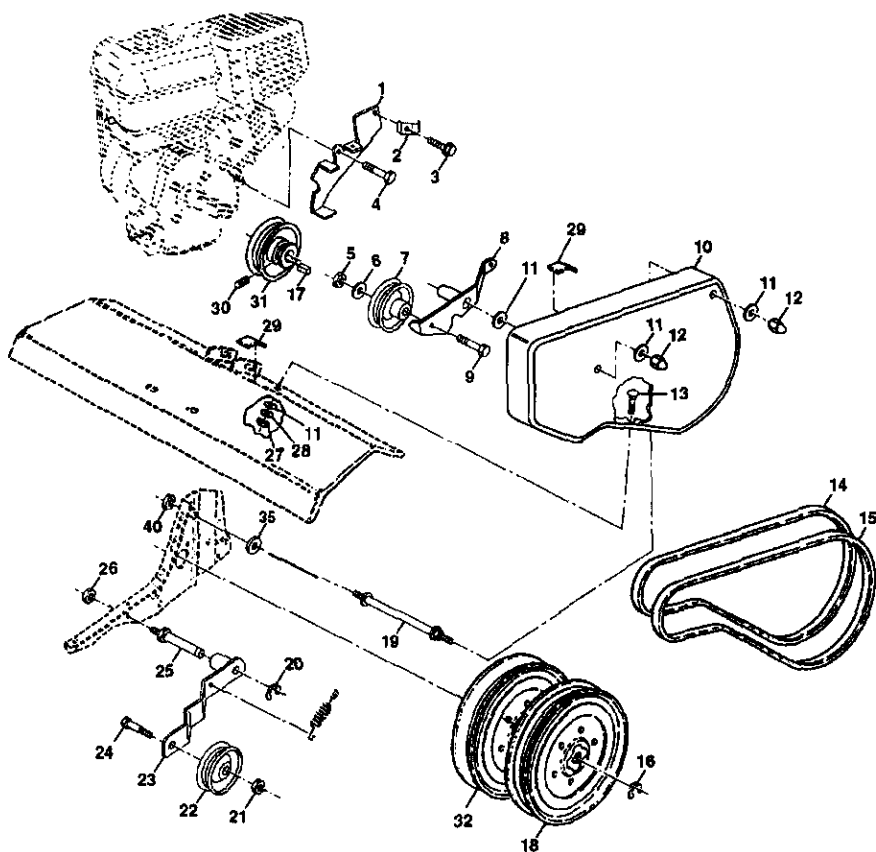

**KEY PART
NO. NO.**

KEY PART NO.	NO.	DESCRIPTION
1	175369	Assembly, Bracket, Belt Guard
2	9484R	Clip, Cable
3	86777	Screw, Hex Washer Hd. Slotted, Thrd cut. #10-24 x 1/2 Type D
4	74610812	Bolt, Hex Head 1/2-20 x 3/4
5	STD541037	Nut, Hex 3/8-16
6	STD551037	Washer 13/32 x 13/16 x 16 Ga.
7	2009J	Pulley, Idler, Reverse
8	175558	Assembly Arm Reverse Idler
9	74760628	Bolt, Hex Hd 3/8-16 x 1-3/4
10	156705X558	Guard, Belt
11	STD551025	Washer 9/32 x 5/8 x 16 Ga.
12	104213X	Nut, Cap 1/4-20
13	72140406	Bolt, Carriage 1/4-20 x 3/4
14	133035	V-Belt (Forward Motion)
15	2614J	V-Belt (Reverse)
16	12000028	Ring, Retainer
17	2649M	Key, Square
18	151236	Sheave, Transmission, flat

**KEY PART
NO. NO.**

KEY PART NO.	NO.	DESCRIPTION
19	165914	Bolt, Belt Guard
20	12000036	Ring, Klip
21	STD541237	Nut, Hex, Jam 3/8-16
22	161806	Pulley, Idler
23	175377	Arm, Idler
24	STD523712	Bolt, Hex Head 3/8-16 x 1-1/4
25	106968X	Shaft, Idler Arm
26	73350500	Nut, Hex, Jam 5/16-18
27	STD541025	Nut, Hex 1/4-20
28	541025	Washer, Lock 1/4
29	109227X	Pad, Idler
30	23200404	Screw Set Socket, Headless C.P. 1/4-20 x 1/4
31	101189L	Sheave, Engine
32	151223	Sheave, Transmission
35	19091416	Washer 9/32 x 7/8 x 16 Ga.
40	STD541425	Nut 1/4-20

NOTE: All component dimensions given in U.S. inches. 1 inch = 25.4 mm

**TILLER -- MODEL NUMBER 917.292490
WHEEL AND DEPTH STAKE ASSEMBLY**

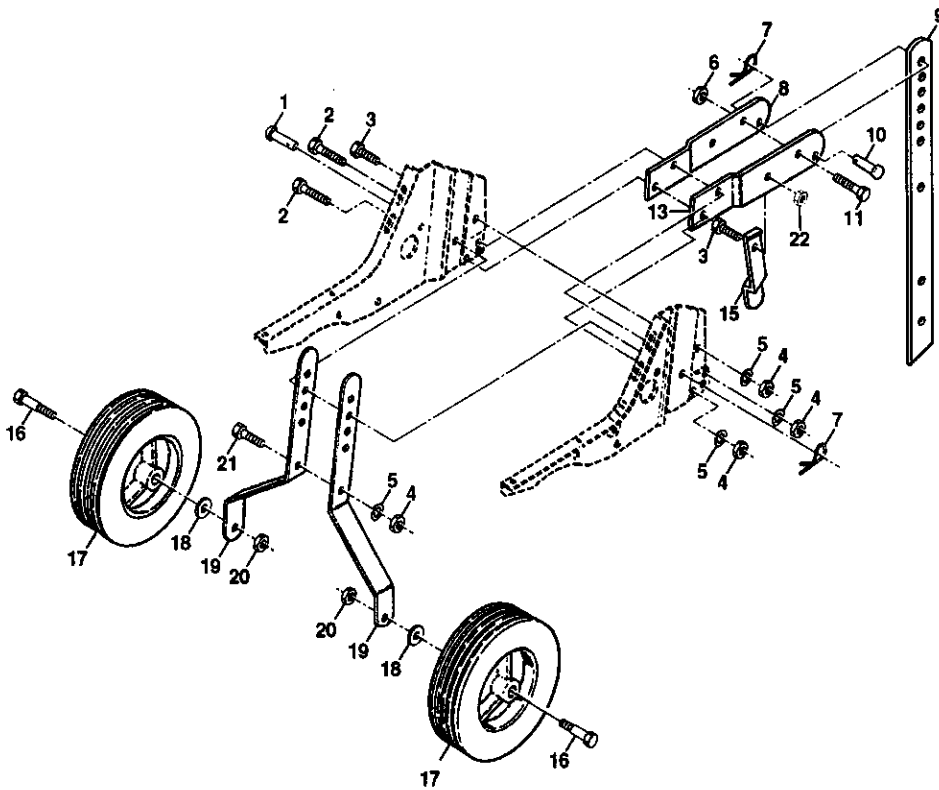

KEY PART NO.	NO.	DESCRIPTION
1	9194R	Pin, Clevis
2	74760520	Bolt, Hex Head 5/16-18 x 1-1/4
3	STD523107	Bolt, Hex Head 5/16-18 x 3/4
4	STD541031	Nut, Hex 5/16-18
5	STD551131	Washer, Lock 5/16
6	STD541437	Locknut, w/washer 3/8-16
7	4921H	Clip, Halpin
8	1952J	Support, Depth Stake, R.H.
9	122233X	Stake, Depth
10	326J	Pin, Clevis
11	74780628	Bolt, Fin, Hex 3/8-16 x 1-3/4
13	1951J	Support, Depth Stake, L.H.

KEY PART NO.	NO.	DESCRIPTION
15	5388J	Spring, Stake
16	121117X	Bolt, Shoulder
17	9188R	Wheel
18	STD551037	Washer 13/32 x 13/16 x 11 Ga.
19	9190R	Bracket, Wheel
20	STD541437	Locknut, Crown 3/8-16
21	74760516	Bolt, Hex Head 5/16-18 x 1
22	STD541431	Locknut, w/insert 5/16-18

NOTE: All component dimensions given in U.S. inches.
1 inch = 25.4 mm

TILLER -- MODEL NUMBER 917.292490

TINE ASSEMBLY

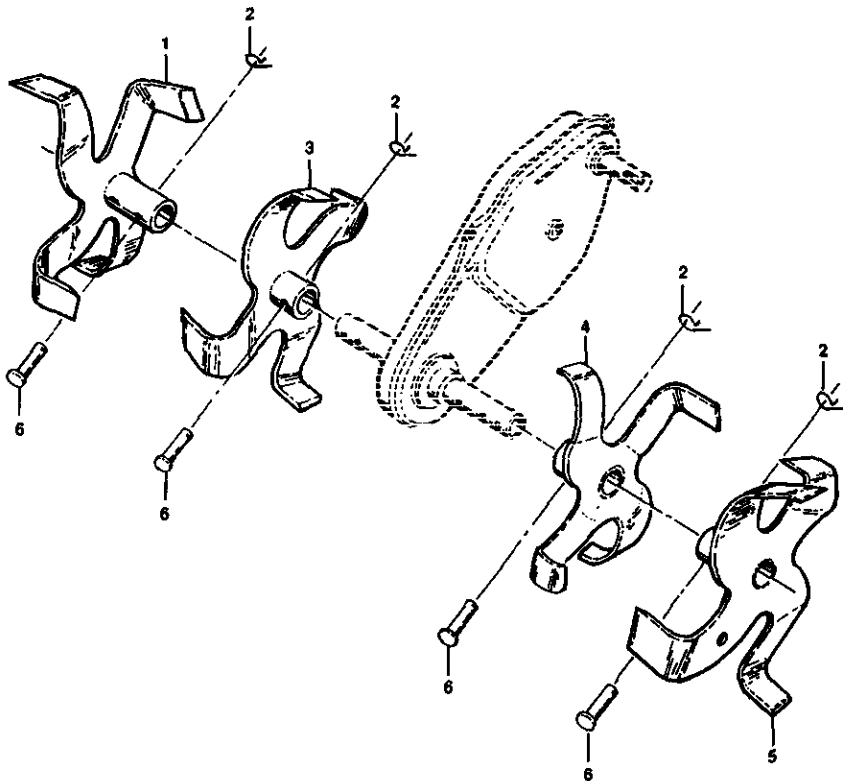

KEY PART NO.	NO.	DESCRIPTION
1	156934	Tine, Outer, R.H.
2	STD624008	Retainer Spring
3	156932	Tine, Inner, R.H.

KEY PART NO.	NO.	DESCRIPTION
4	156931	Tine, Inner, L.H.
5	156933	Tine, Outer, L.H.
6	4929H	Pin, Clevis

TILLER - - MODEL NUMBER 917.292490

TRANSMISSION

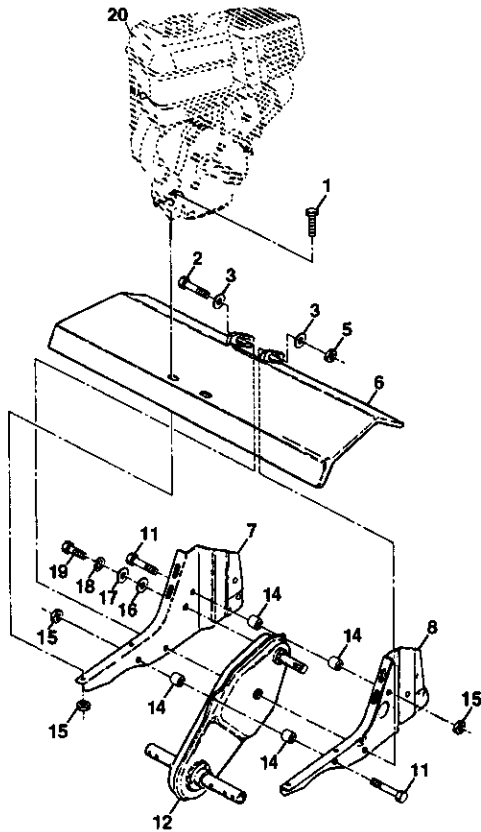

KEY PART NO.	NO.	DESCRIPTION
1	74760524	Bolt, Hex 5/16-18 x 1-1/2 Gr. 2
2	STD523732	Bolt, Fin, Hex 3/8-16 x 3-1/4
3	STD551037	Washer 13/32 x 13/16 x 11
5	STD541437	Locknut, w/washer 3/8-16
6	9057R558	Shield, Tine
7	165835	Bracket, Engine, R.H.
8	1948J	Bracket, Engine, L.H.
11	74760544	Bolt, Hex Head 5/16-18 x 2-3/4
12	176112	Transmission
14	9173R	Spacer, Split
15	73970500	Nut, Hex, Keps 5/16-18 UNC

KEY PART NO.	NO.	DESCRIPTION
16	19091412	Washer 9/32 x 7/8 x 12 Gauge
17	19092016	Washer 9/32 x 1-1/4 x 16 Ga.
18	STD551125	Washer, Lock 1/4
19	74610412	Bolt, Hex 1/4-28 x 3/4 Grade 5
20	-----	Engine, (See Breakdown) Briggs Model No. 110402-0206-E1

NOTE: All component dimensions given in U.S. inches. 1 Inch = 25.4 mm

TILLER -- MODEL NUMBER 917.292490

DECALS

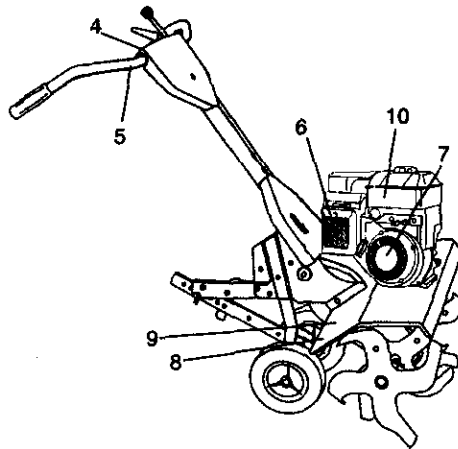
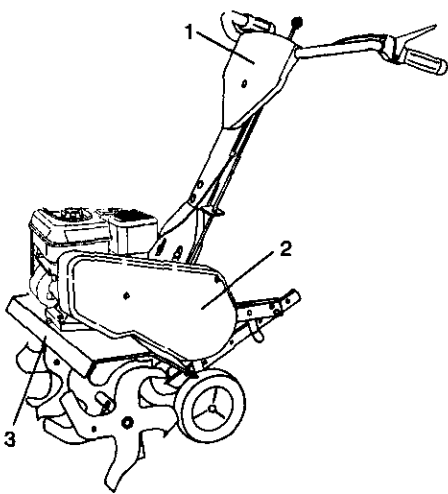

KEY PART NO.	NO.	DESCRIPTION
1	176943	Decal, Cntrl. Pnl Ser
2	176941	Decal, Belt Grd
3	166131	Decal, Logo
4	137653	Decal, Caution, Tine Control
5	120431X	Decal, Hand Placement
6	176783	Decal, Engine Operation
7	171078	Decal, Rewind Intek
8	120075X	Decal, Warning, Rotating Tines
9	162215	Decal, Tine Shield
10	167156	Decal, B & S Intek
--	176859	Manual, Owner's(Eng/Span)

TILLER -- MODEL NUMBER 917.292490
BRIGGS & STRATTON ENGINE -- MODEL NUMBER 110402, TYPE NO. 0206-E1

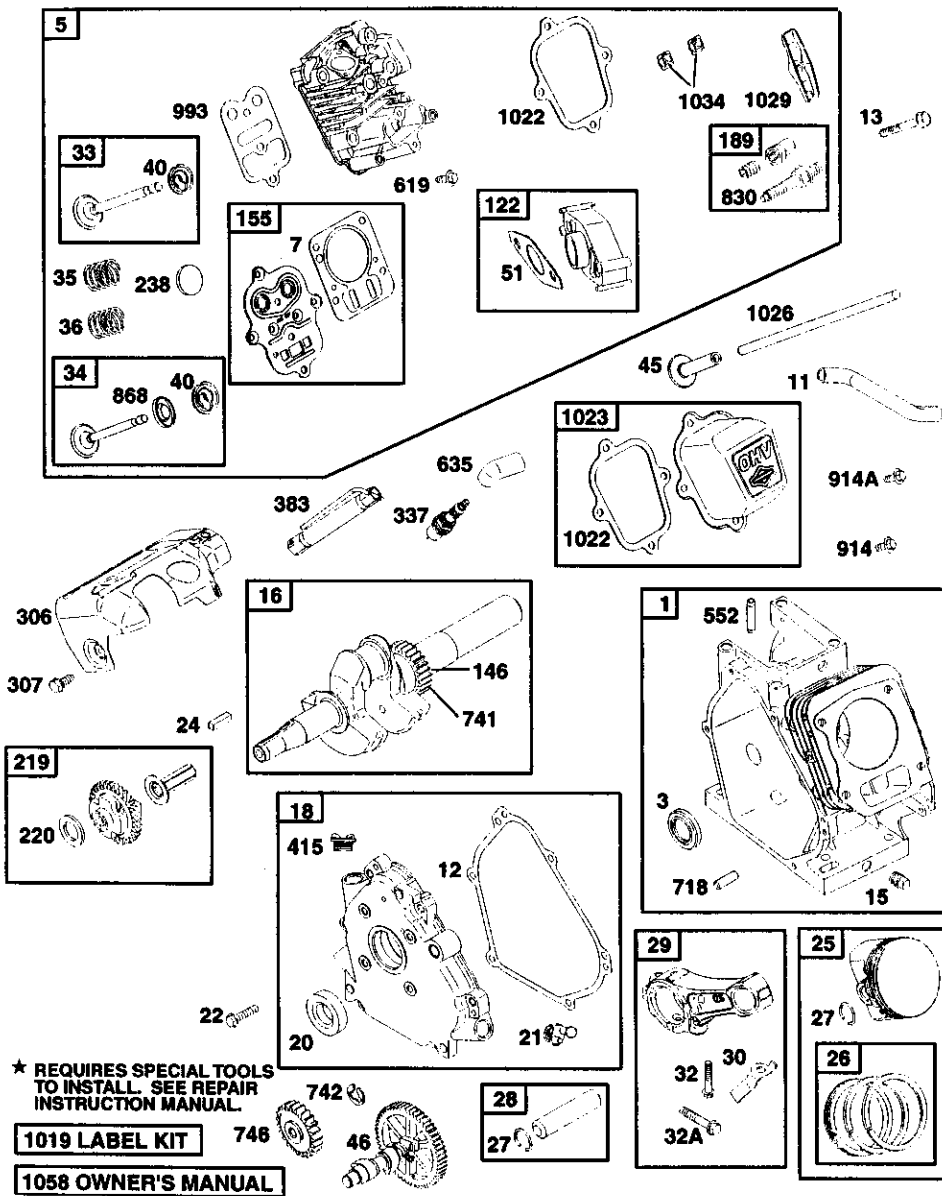

TILLER -- MODEL NUMBER 917.292490
BRIGGS & STRATTON ENGINE -- MODEL NUMBER 110402, TYPE NO. 0206-E1

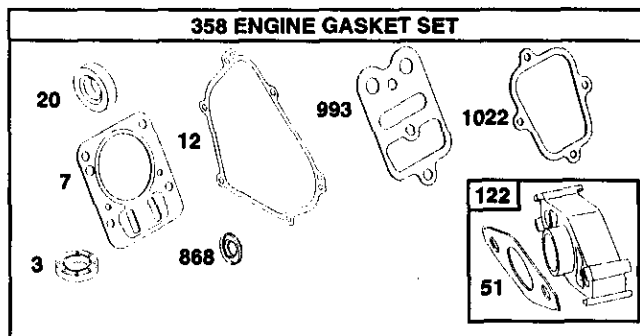
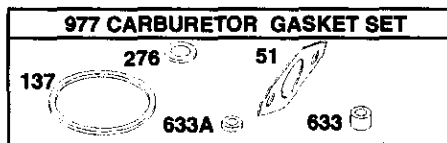
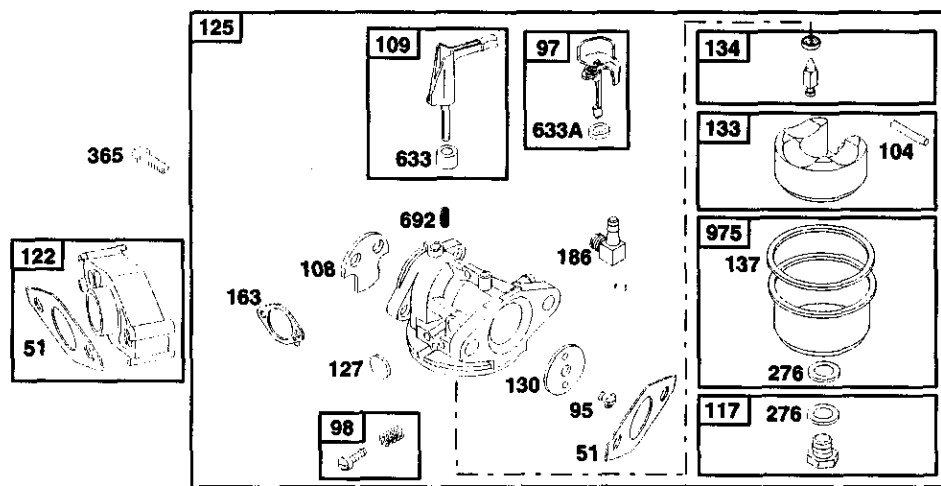

TILLER -- MODEL NUMBER 917.292490
BRIGGS & STRATTON ENGINE -- MODEL NUMBER 110402, TYPE NO. 0206-E1

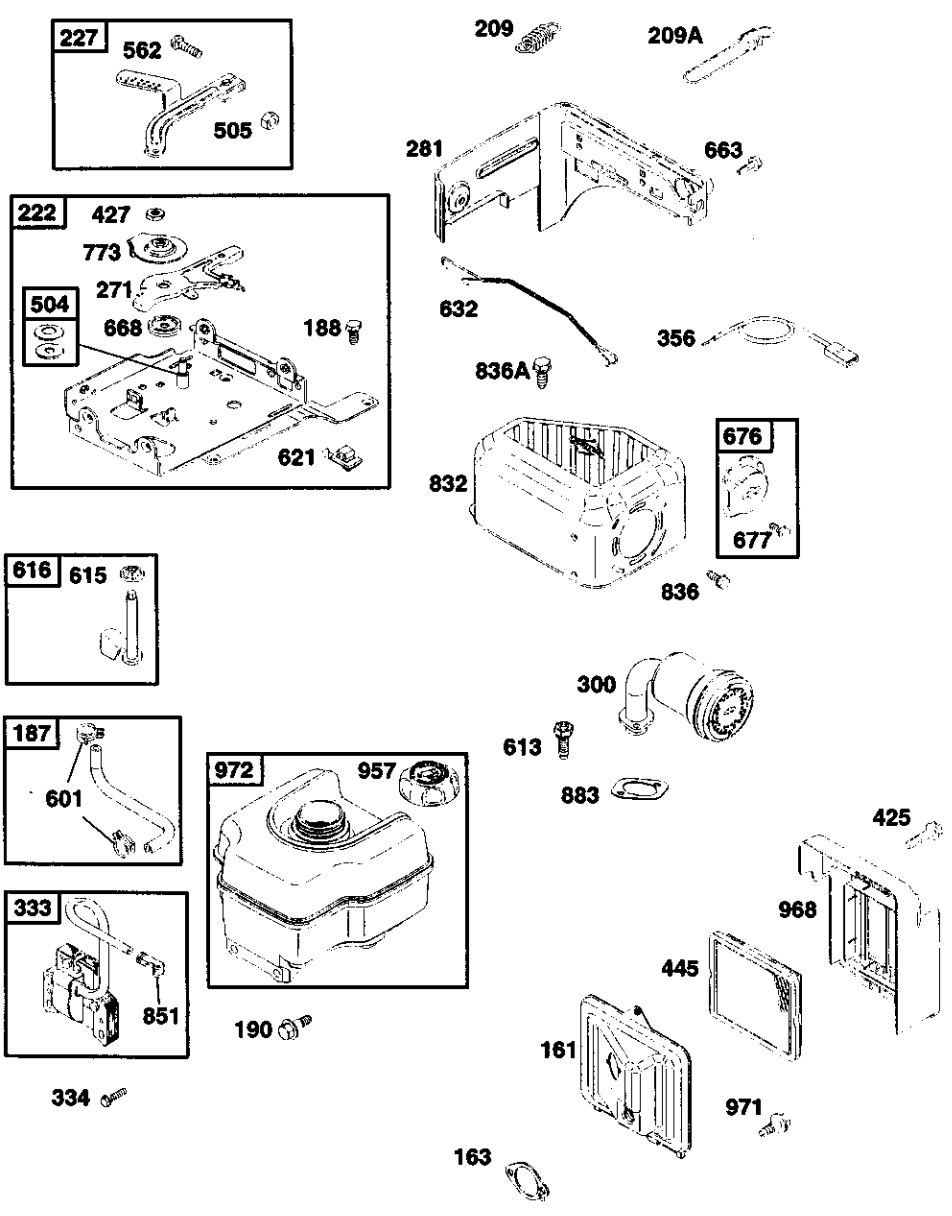

TILLER -- MODEL NUMBER 917.292490
BRIGGS & STRATTON ENGINE -- MODEL NUMBER 110402, TYPE NO. 0206-E1

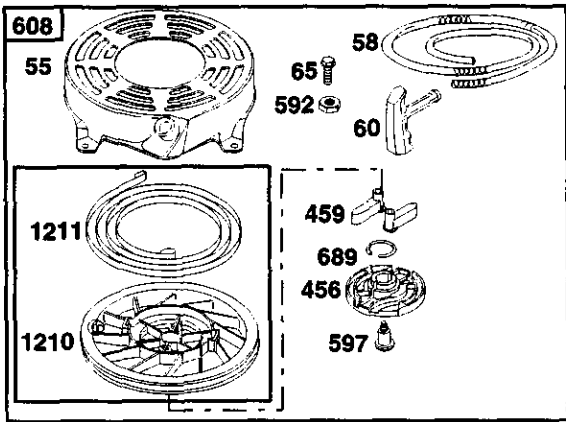

1036 EMISSIONS LABEL

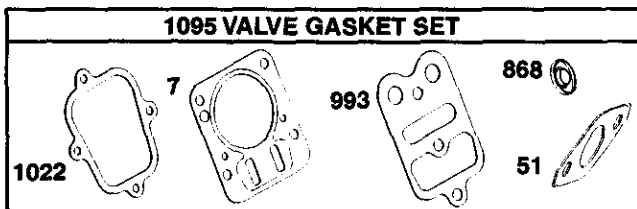
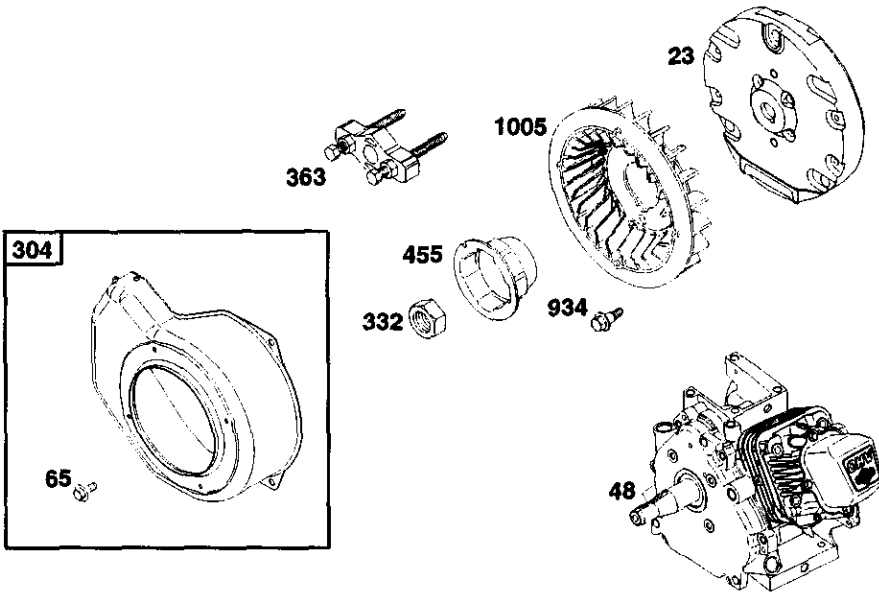

TILLER -- MODEL NUMBER 917.292490
BRIGGS & STRATTON ENGINE -- MODEL NUMBER 110402, TYPE NO. 0206-E1

KEY NO.	PART NO.	DESCRIPTION	KEY NO.	PART NO.	DESCRIPTION
1	693811	Cylinder Assembly	104	691242	Ø Pin-Float Hinge
3	299819	• Seal-Oil (Magneto Side)	108	692567	Valve-Choke
5	693643	Head-Cylinder	109	690023	Shaft-Choke
7	695166	*+ Gasket-Cylinder Head	117	694975	Jet-Main (Standard)
11	692600	Tube-Breather	121	695157	Kit-Carburetor Overhaul
12	692549	• Gasket-Crankcase	122	693749	• Ø Spacer-Carburetor
13	691137	Screw (Cylinder Head)	125	696065	Carburetor
15	691686	Plug-Oil Drain	127	691739	Ø Plug-Weich
16	693797	Crankshaft	130	691181	Valve-Throttle
18	694466	Cover-Crankcase	133	398187	Float-Carburetor
20	692550	• Seal-Oil (PTO Side)	134	398188	Ø Kit-Needle/Seat
21	281658	Cap-Oil Fill	137	693981	Ø‡ Gasket-Float Bowl
22	691662	Screw (Engine Sump)	146	690979	Key-Timing
23	692987	Flywheel	155	695882	Plate-Cylinder Head
24	222698	Key-Flywheel	161	696063	Base-Air Cleaner
25	690021	Piston Assembly (Standard)	163	696024	Gasket-Air Cleaner
	694167	Piston Assembly (.010" O.S.)	186	692317	Connector-Hose
	694168	Piston Assembly (.020" O.S.)	187	693401	Line-Fuel (Molded)
	694169	Piston Assembly (.030" O.S.)	188	690877	Screw (Control Bracket)
26	499631	Ring Set-Piston (Standard)	189	694543	Ball-Rocker Arm
	692785	Ring Set-Piston (.010" O.S.)	190	692127	Screw (Fuel Tank)
	692786	Ring Set-Piston (.020" O.S.)	209	691278	Spring-Governor
	692787	Ring Set-Piston (.030" O.S.)	209A	692571	Spring-Governor
27	691866	Lock-Piston Pin	219	693578	Gear-Governor
28	499423	Pin-Piston	220	691724	Washer (Governor Gear)
29	499424	Rod-Connecting	222	694253	Bracket-Control
30	692562	Dipper-Connecting Rod	227	692573	Control Lever-Governor
32	691664	Screw (Connecting Rod)	238	691300	Cap-Valve
32A	695759	Screw (Connecting Rod)	271	694256	Lever-Control
33	499642	Valve-Exhaust	276	271716	Ø‡ Sealing Washer
34	499641	Valve-Intake	281	694252	Panel-Control
35	691304	Spring-Valve (Intake)	300	693593	Muffler
36	691304	Spring-Valve (Exhaust)	304	696066	Housing-Blower
40	692194	Retainer-Valve	306	693610	Shield-Cylinder
45	690977	Tappet-Valve	307	690345	Screw (Cylinder Shield)
46	693404	Camshaft			RPM Settings: Low Speed: 1900-2100
48		Short Block (Replacement Engine)			High Speed: 3000-3200
51	692555	• Ø‡+ Gasket-Intake			• Included in Engine Gasket Set, Key. No. 358
55	691421	Housing-Rewind Starter	Ø		Included in Carburetor Overhaul Kit, Key. No. 121
58	692259	Rope-Starter (Cut to Required Length)	‡		Included in Carburetor Gasket Set, Key. No. 977
60	281434	Grip-Starter Rope	+		Included in Valve Gasket Set, Key. No. 1095
65	690837	Screw (Rewind Starter)			
95	691636	Screw (Throttle Valve)			
97	690024	Shaft-Throttle			
98	398185	Kit-Idle Speed			

NOTE: All component dimensions given in U.S. inches 1 inch = 25.4 mm

TILLER -- MODEL NUMBER 917.292490
BRIGGS & STRATTON ENGINE -- MODEL NUMBER 110402, TYPE NO. 0206-E1

KEY NO.	PART NO.	DESCRIPTION	KEY NO.	PART NO.	DESCRIPTION
332	690662	Nut (Flywheel)	742	692564	Retainer-E Ring
333	692605	Armature-Magneto	746	692566	Gear-Idler
334	691061	Screw (Armature Magneto)	773	694258	Retainer
337	491055	Spark Plug	830	694544	Stud (Rocker Arm)
356	692390	Wire-Stop	832	693583	Guard-Muffler
358	695155	Engine Gasket Set	836	690661	Screw (Muffler Guard)
363	19069	Flywheel Puller	836A	693624	Screw (Muffler Guard)
365	692568	Screw (Carburetor)	851	493880	Terminal-Sparkplug
383	19374	Wrench-Spark Plug	868	692044	*+ Seal-Valve
415	693463	Plug	883	691893	*+ Gasket-Exhaust
425	692583	Screw (Air Cleaner Cover)	914	692198	Screw (Rocker Cover)
427	694255	Nut (Control Bracket)	914A	692557	Screw (Rocker Cover)
445	491588	Filter-Air Cleaner Cartridge	957	694261	Cap-Fuel Tank
455	692591	Cup-Flywheel	968	692584	Cover-Air Cleaner
456	692299	Plate-Pawl Friction	971	690370	Screw (Air Cleaner Base)
459	281505	Pawl-Ratchet	972	694260	Tank-Fuel
504	694254	Washer Set	975	493640	Bowl-Float
505	691251	Nut (Governor Control Lever)	977	695156	Set-Carburetor Gasket
552	692346	Bushing-Governor Crank	993	691892	*+ Gasket-Cylinder Head Plate
562	691112	Bolt (Governor Control Lever)	1005	692592	Fan-Flywheel
592	690800	Nut (Rewind Starter)	1019	694851	Kit-Label
597	691696	Screw (Pawl Friction Plate)	1022	691890	*+ Gasket-Rocker Cover
601	95162	Clamp-Hose	1023	499924	Cover-Rocker
608	497680	Starter-Rewind	1026	693517	Rod-Push
613	691665	Screw (Muffler)	1029	691230	Arm-Rocker
615	692576	Retainer-Governor Shaft	1034	691343	Guide-Push Rod
616	692547	Crank-Governor	1036	695041	Label-Emissions
619	691108	Screw (Cylinder Head Plate)	1058	274263	Owner's Manual
621	692310	Switch-Stop	1095	695289	Set-Valve Gasket
632	693408	Spring/Link-Mechanical Governor	1162	692590	Screw (Flywheel Fan)
633	693867	∅‡ Seal-Choke/Throttle Shaft	1210	498144	Assembly-Pulley/Spring (Pulley)
633A	691321	∅‡ Seal-Throttle Shaft	1211	498144	Assembly-Pulley/Spring (Spring)
635	692076	Boot-Sparkplug			RPM Settings:Low Speed: 1900-2100 High Speed: 3000-3200
663	694593	Screw (Control Panel)			
668	694257	Spacer			
676	393757	Deflector-Muffler	•		Included in Engine Gasket Set, Key. No. 358
677	690661	Screw (Muffler Deflector)	∅		Included in Carburetor Overhaul Kit, Key. No. 121
689	691855	Spring-Friction	‡		Included in Carburetor Gasket Set, Key. No. 977
692	690572	Spring-Detent	+		Included in Valve Gasket Set, Key. No. 1095
718	690959	Pin-Locating			
741	692565	Gear-Timing			

NOTE: All component dimensions given in U.S. inches 1 inch = 25.4 mm

Get it fixed, at your home or ours!

For repair of major brand appliances **in your own home...**
no matter who made it, no matter who sold it!

1-800-4-MY-HOMESM Anytime, day or night
(1-800-469-4663)

www.sears.com

To bring in products such as vacuums,
lawn equipment and electronics for repair, call for
the location of your nearest **Sears Parts & Repair Center.**

1-800-488-1222 Anytime, day or night

www.sears.com

For the replacement parts, accessories and owner's manuals
that you need to do-it-yourself, call **Sears PartsDirect**SM!

1-800-366-PART 6 a.m. – 11 p.m. CST,
(1-800-366-7278) 7 days a week

www.sears.com/partsdirect

To purchase or inquire about a Sears Service Agreement:

1-800-827-6655

7 a.m. – 5 p.m. CST, Mon. – Sat.

Para pedir servicio de reparación a domicilio,
y para ordenar piezas con entrega a domicilio:

1-888-SU-HOGARSM
(1-888-784-6427)

Au Canada pour service en français:

1-877-LE-FOYERSM
(1-877-533-6837)



© Sears, Roebuck and Co.

® Registered Trademark / ™ Trademark of Sears, Roebuck and Co.
® Marca Registrada / ™ Marca de Fábrica de Sears, Roebuck and Co.

Free Manuals Download Website

<http://myh66.com>

<http://usermanuals.us>

<http://www.somanuals.com>

<http://www.4manuals.cc>

<http://www.manual-lib.com>

<http://www.404manual.com>

<http://www.luxmanual.com>

<http://aubethermostatmanual.com>

Golf course search by state

<http://golfingnear.com>

Email search by domain

<http://emailbydomain.com>

Auto manuals search

<http://auto.somanuals.com>

TV manuals search

<http://tv.somanuals.com>