

OWNER'S MANUAL



**6.0 Horsepower
2400 PSI 2.4 GPM
High Pressure Washer**

**Model No:
919.670280**



WARNING: Before using this product, read this manual and follow all Safety Rules and Operating Instructions.



- Safety
- Assembly
- Operation
- Maintenance
- Parts List
- Français

Sold by Sears Canada, Inc., Toronto, Ont. M5B2B8

TABLE OF CONTENTS

Warranty	2	Storage	15
Safety Guidelines- Definitions	2	Troubleshooting	16
Safety Guidelines	3-4	Parts	17
Assembly	5-7	Pump Parts	18-19
Operation	7-10	Engine Parts	20-26
Product Specifications	11	How to Order Parts	24
Maintenance	11-13	Français	25
Service and Adjustments	14		

FULL ONE YEAR WARRANTY ON CRAFTSMAN HIGH PRESSURE WASHER

For one year from the date of purchase, when this Craftsman High Pressure Washer is maintained and operated according to the instructions in the owner's manual, Sears will repair, free of charge, any defect in material and workmanship.

If your Craftsman Pressure Washer is used for commercial or rental purposes, this warranty applies only for 90 days from the date of purchase.

FULL TWO YEAR WARRANTY ON CRAFTSMAN ENGINE

For two years from the date of purchase, when this Craftsman engine is maintained and operated according to the instructions in the owner's manual, Sears will repair, free of charge, any defect in material and workmanship.

If your Craftsman engine is used for commercial or rental purposes, this warranty applies only for 90 days from the date of purchase. This warranty does not cover expendable items such as spark plugs and air filters, which become worn during normal use.

Repairs necessary because of operator abuse or negligence, including damage resulting from no water being supplied to pump or failure to maintain the equipment according to the instructions contained in the owner's manual, are not covered under warranty.

WARRANTY SERVICE IS AVAILABLE BY RETURNING THE HIGH PRESSURE WASHER TO THE NEAREST SEARS SERVICE CENTER THROUGHOUT THE UNITED STATES. This warranty gives you specific legal rights and you may also have other rights, which vary from state to state.

Sears Canada, Inc., Toronto, Ont. M5B2B8

SAFETY GUIDELINES - DEFINITIONS

This manual contains information that is important for you to know and understand. This information relates to protecting **YOUR SAFETY** and **PREVENTING EQUIPMENT PROBLEMS**. To help you recognize this information, we use the symbols below. Please read the manual and pay attention to these sections. **SAVE THESE DEFINITIONS/INSTRUCTIONS.**

▲ WARNING indicates a potentially hazardous situation which, if not avoided, **could** result in **death or serious injury**.



▲ DANGER indicates an imminently hazardous situation which, if not avoided, **will** result in **death or serious injury**.

▲ CAUTION indicates a potentially hazardous situation which, if not avoided, **may** result in **minor or moderate injury**.



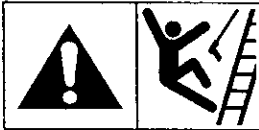

IMPORTANT SAFETY INSTRUCTIONS

⚠ WARNING

Improper operation or maintenance of this product could result in serious injury and property damage. Read and understand all warnings and operating instructions before using.

HAZARD	WHAT CAN HAPPEN	HOW TO PREVENT IT
<p style="text-align: center;">⚠ DANGER RISK OF EXPLOSION OR FIRE</p> 	<ul style="list-style-type: none"> • Spilled gasoline and its vapors can become ignited from cigarette sparks, electrical arcing, exhaust gases, and hot engine components such as the muffler. • Heat will expand fuel in the tank which could result in spillage and possible fire explosion. • Operating the pressure washer in an explosive environment could result in a fire. • Materials placed against or near the pressure washer can interfere with its proper ventilation features causing overheating and possible ignition of the materials. • Muffler exhaust heat can damage painted surfaces, melt any material sensitive to heat (such as siding, plastic, rubber, or vinyl), and damage live plants. • Improperly stored fuel could lead to accidental ignition. Fuel improperly secured could get into the hands of children or other unqualified persons. • Use of acids, toxic or corrosive chemicals, poisons, insecticides, or any kind of flammable solvent with this product could result in serious injury or death. 	<ul style="list-style-type: none"> • Shut off engine and allow it to cool before adding fuel to the tank. • Use care in filling tank to avoid spilling fuel. Move pressure washer away from fueling area before starting engine. • Keep maximum fuel level ½" below top of tank to allow for expansion. • Operate and fuel equipment in well ventilated areas free from obstructions. Equip areas with fire extinguishers suitable for gasoline fires. • Never operate pressure washer in an area containing dry brush or weeds. • Always keep pressure washer a minimum of four feet away from surfaces (such as houses, automobiles, or live plants) that could be damaged from muffler exhaust heat. • Store fuel in an OSHA approved container, in a secure location away from work area. • Do not spray flammable liquids
<p style="text-align: center;">⚠ DANGER RISK TO BREATHING</p> 	<ul style="list-style-type: none"> • Breathing exhaust fumes will cause serious injury or death. • Some cleaning fluids contain substances which could cause injury to skin, eyes, or lungs. 	<ul style="list-style-type: none"> • Operate pressure washer in a well ventilated area. Avoid enclosed areas such as garages, basements, etc. • Never operate unit in a location occupied by humans or animals. • Use only cleaning fluids specifically recommended for high pressure washers. Follow manufacturers recommendations.
<p style="text-align: center;">⚠ WARNING RISK OF UNSAFE OPERATION</p> 	<ul style="list-style-type: none"> • Unsafe operation of your pressure washer could lead to serious injury or death to you or others. • The spray gun/wand is a powerful cleaning tool that could look like a toy to a child. • Reactive force of spray will cause gun/wand to move, and could cause the operator to slip or fall, or misdirect the spray. Improper control of gun/wand can result in injuries to self and others. 	<ul style="list-style-type: none"> • Become familiar with the operation and controls of the pressure washer. • Keep operating area clear of all persons, pets, and obstacles. • Do not operate the product when fatigued or under the influence of alcohol or drugs. Stay alert at all times. • Never defeat the safety features of this product. • Do not operate machine with missing, broken, or unauthorized parts. • Never leave wand unattended while unit is running. • Keep children away from the pressure washer at all times. • Do not overreach or stand on an unstable support. Grip gun/wand firmly with both hands. Expect the gun to kick when triggered.

IMPORTANT SAFETY INSTRUCTIONS

HAZARD	WHAT CAN HAPPEN	HOW TO PREVENT IT
<p>⚠ WARNING</p> <p>RISK OF ELECTRICAL SHOCK</p> 	<ul style="list-style-type: none"> Spray directed at electrical outlets or switches, or objects connected to an electrical circuit, could result in a fatal electrical shock. 	<ul style="list-style-type: none"> Unplug any electrically operated product before attempting to clean it. Direct spray away from electric outlets and switches.
<p>⚠ WARNING</p> <p>RISK TO FLUID INJECTION</p> 	<ul style="list-style-type: none"> Your washer operates at fluid pressures and velocities high enough to penetrate human and animal flesh, which could result in amputation or other serious injury. Leaks caused by loose fittings or worn or damaged hoses can result in injection injuries. DO NOT TREAT FLUID INJECTION AS A SIMPLE CUT! See a physician immediately! Relieve system pressure before attempting maintenance or disassembly of equipment. 	<ul style="list-style-type: none"> Never place hands in front of nozzle. Direct spray away from self and others. Make sure hose and fittings are tightened and in good condition. Never hold onto the hose or fittings during operation. Do not allow hose to contact muffler. Never attach or remove wand or hose fittings while system is pressurized. Use only hose and high pressure accessories rated for pressure higher than your pressure washer's p.s.i. To relieve system pressure, shut off engine, turn off water supply, and pull gun trigger until water stops flowing.
<p>⚠ WARNING</p> <p>RISK OF CHEMICAL BURN</p> 	<ul style="list-style-type: none"> Use of acids, toxic or corrosive chemicals, poisons, insecticides, or any kind of flammable solvent with this product could result in serious injury or death. 	<ul style="list-style-type: none"> Do not use acids, gasoline, kerosene, or any other flammable materials in this product. Use only household detergents, cleaners and degreasers recommended for use in pressure washers. Wear protective clothing to protect eyes and skin from contact with sprayed materials.
<p>⚠ WARNING</p> <p>RISK OF HOT SURFACES</p> 	<ul style="list-style-type: none"> Contact with hot surfaces, such as engines exhaust components, could result in serious burn. 	<ul style="list-style-type: none"> During operation, touch only the control surfaces of the pressure washer. Keep children away from the pressure washer at all times. They may not be able to recognize the hazards of this product.
<p>⚠ DANGER</p> <p>RISK OF INJURY AND PROPERTY DAMAGE WHEN TRANSPORTING OR STORING</p> 	<ul style="list-style-type: none"> Fuel or oil can leak or spill and could result in fire or breathing hazard, serious injury or death can result. Fuel or oil leaks will damage carpet, paint or other surfaces. 	<ul style="list-style-type: none"> If pressure washer is equipped with a fuel shut-off valve, turn the valve to the off position before transporting or storing to avoid fuel leaks. If pressure washer is not equipped with a fuel shut-off valve, drain the fuel from tank before transporting or storing. Only store fuel in an OSHA approved container. Always place pressure washer on a protective mat when transporting to protect against damage to vehicle from leaks. Remove pressure washer from vehicle immediately upon arrival at your destination. Do not store pressure washer inside buildings occupied by humans or pets.

IMPORTANT SAFETY INSTRUCTIONS

⚠ CAUTION

The powerful spray from your pressure washer is capable of causing damage to fragile surfaces such as: wood, glass, automobile paint, auto stripping and trim, and delicate objects such as flowers and shrubs. Before spraying, check the item to be cleaned to assure yourself that it is robust enough to resist damage from the force of the spray. Avoid the use of the concentrated spray stream except for very strong surfaces like concrete and steel.

Operating unit with water supply shut off without flow of water will result in equipment damage. You should never run this pressure washer for more than 2 minutes without pulling the trigger to allow cool water to enter the pump and the heated (recirculated) water to exit. Running the pressure washer with water supply shut off will void your warranty.

International Symbols



Safety Alert - Read Owner's Manual



On Off



Stop



Fuel Shutoff



Fuel



Choke

ASSEMBLY

Carton Contents

- Main Unit pressure washer with wheels
- Handle
- High Pressure Hose



Main Unit Pressure Washer with Wheels

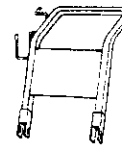

Handle



High Pressure Hose

Bag Containing

- Chemical/Soap Hose and Filter
- Gun
- Wand

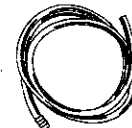

Chemical/Soap Hose and Filter

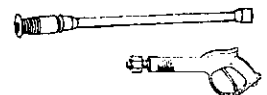

Gun and Wand

Bag Containing

- Video Cassette
- Owner's Manual
- Nozzle Cleaning Kit
- 2 mm Allen Wrench
- 5 mm Allen Wrench
- Replacement O-Rings
- Engine Oil
- Rubber Isolator and Mounting Hardware
- Handle Mounting Hardware



Video Cassette



Owner's Manual

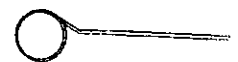

Nozzle Cleaning Tool



2 mm Allen Wrench



5 mm Allen Wrench



Replacement O-Rings

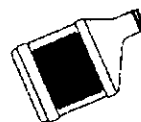

Engine Oil



Rubber Isolator and Mounting Hardware

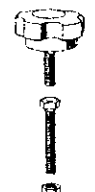

Handle Mounting Hardware

Tools Required for Assembly

Adjustable wrench

5 mm Allen wrench (supplied)

Remove Pressure Washer from Carton

- Open carton from the top. Locate and remove from box the handle, gun, wand, chemical/soap hose, and parts bag.
- Cut carton along dotted lines.
- Remove all carton inserts.
- Roll unit through opening in carton.

NOTE: The hose is located at the bottom of the box.

Preparing the Pressure Washer for First Use

Note: Included with your pressure washer is a video cassette tape on how to prepare your unit for operation. It is recommended you view this tape before performing the next steps.

1. Insert handle onto frame.
 - Insert knobs into the threaded slot in front of the frame handle and tighten by turning in a clockwise direction.
 - Slide bolts into the slot in the side of the frame handle and tighten the nuts by turning in a clockwise direction.

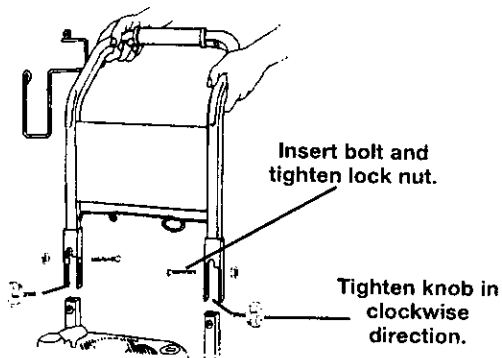

2. Using an adjustable wrench, remove nut from bolt that attaches board to frame. Remove wood plank from the frame of the unit. Discard bolt and board.

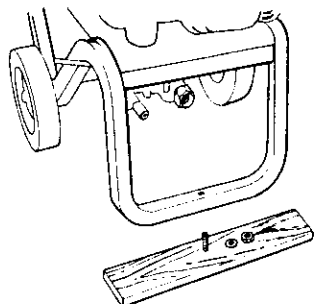

3. Mount the rubber isolator to the frame. To mount isolator place threaded end of bolt through the washer.
 - Next with washer on bolt place threaded end of bolt through the larger hole in bottom of the rubber isolator.
 - Place threaded portion of bolt through the same hole location the wood plank was mounted to on the pressure washer.
 - Next place the tee nut over the threaded portion of the bolt and use the 5 mm Allen wrench provided to tighten isolator to the frame.

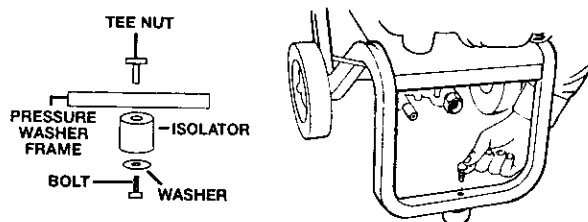

4. Connect wand extension to gun. To tighten, turn knob in clockwise direction. Hand tighten.

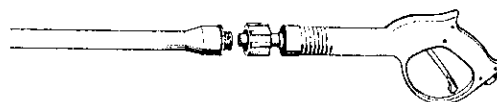

5. Remove tie wrap off of high pressure hose. Unwind high pressure hose and attach the threaded end to the gun. Tighten with adjustable wrench.

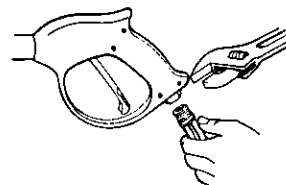

6. Connect high pressure hose to outlet on pressure washer and hand tighten firmly.

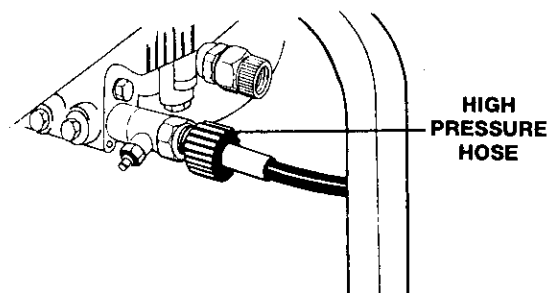

NOTE: Always keep hose away from engine muffler.

- Place assembled gun and wand on pressure washer holder.



- Place pull cord into the wire bracket holder.
 - Pull the cord under the wire bracket to the right of the wire loop.
 - Lift the pull cord handle up and slide the cord to the left, sliding the cord into the wire loop.
 - Next slide handle behind the wire bracket to the left of the wire loop.
 - Engine recoil will pull the cord into its final position.

Checklist

Before going any further please review the following:

- Be sure you have completed assembly instructions.
- Double check all fittings to be sure they are tight.

IMPORTANT: Before any attempt to start your pressure washer be sure to check engine oil (See Engine Oil on page 8.)

OPERATION

Know Your High Pressure Washer

Read this Owner's Manual and Safety Rules before operation of your High Pressure Washer
Compare this illustration with our pressure washer to familiarize yourself with the location of various controls and adjustments. Save this manual for future reference.

PUMP- Develops high pressure.

ENGINE RUN/STOP SWITCH- Sets engine in starting mode for recoil starter — **Stops** running engine.

RECOIL STARTER- Used for starting the engine manually.

SPRAY GUN ASSEMBLY (Contains Gun and Wand)- Controls the application of water onto cleaning surface with trigger device.

OIL FILL- Port where engine oil is poured.

GAS TANK/CAP- Cap is removed and unleaded gasoline is poured.

HIGH PRESSURE OUTLET- Connection for high pressure hose.

CHOKE- Used to start a cold engine.

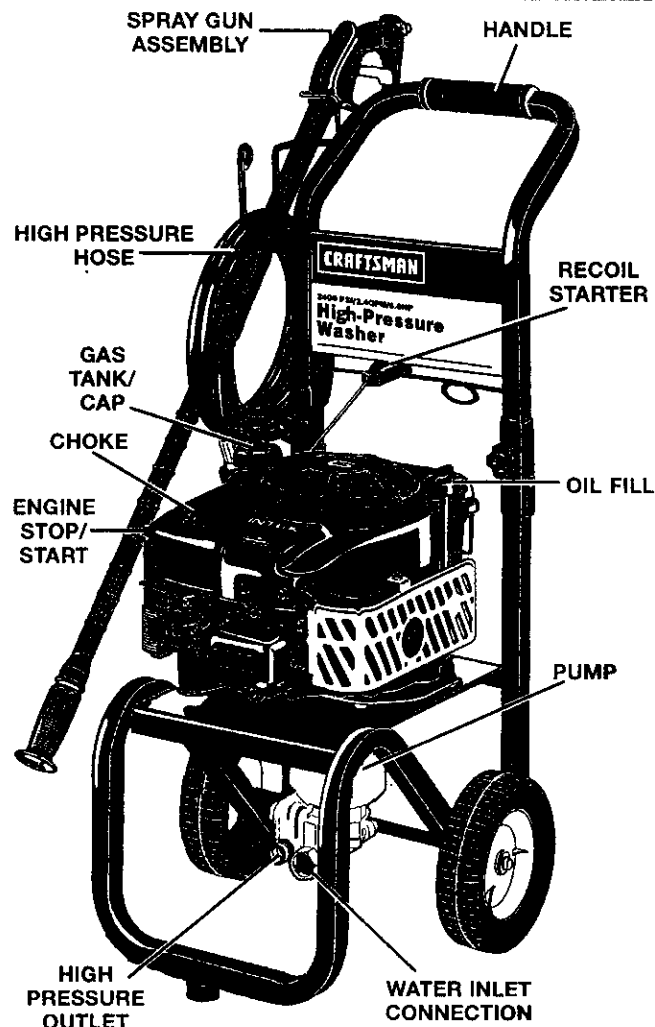

▲ WARNING: Read Owner's Manual. Do not attempt to operate equipment until you have read Owners Manual for Safety, Operation, and Maintenance Instructions.

Note: Included with your unit is a video cassette that demonstrates how to operate your pressure washer. If you have a video cassette recorder you should view the video before operation.

▲ WARNING: Never adjust spray pattern when spraying. Never put hands in front of spray nozzle to adjust spray pattern you could be injured.

Stopping Your Pressure Washer

▲ CAUTION: Do not run pump without the water supply connected and turned on. Failure to do so will result in pump damage.

- Move throttle control to the stop position to turn pressure washer off.

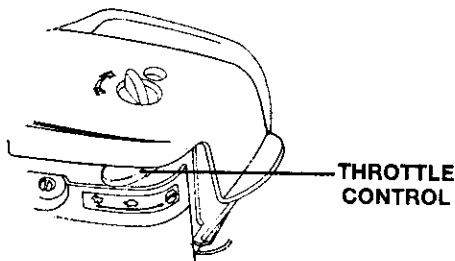

- Simply shutting OFF engine will not release pressure in the system. After engine has stopped, squeeze the trigger on the spray gun for about 3 seconds to relieve pressure. Spray stream will decrease in length.

IMPORTANT: This unit is equipped with a thermal relief valve. If unit is allowed to run for several minutes without pressing the trigger on the spray gun, several drops of water may be released through this valve to cool the unit. This small amount of water will drip from the bottom of the pump.

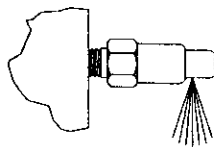

Before Starting The Engine

To operate the engine you will need to do the following.

▲ CAUTION: Always check engine oil level before every start. Running engine low of oil or out of oil could result in serious damage.

Engine Oil

Your unit has been shipped **without** oil in the engine. A bottle of SAE 30 weight oil is included in the carton. Remove oil dip stick located on top of the engine. Oil capacity is about 20 ounces of oil. The oil dip stick is clearly marked with a line that tells you when unit has enough oil. To check oil, place dipstick into oil fill. Tighten dipstick then remove. Do not fill above this point. Pour slowly.

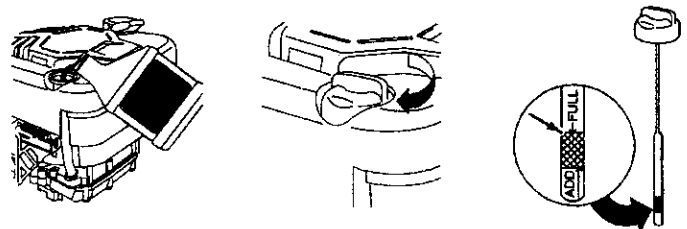

NOTE: When adding oil to the engine crankcase, use a high quality detergent oil classified "For Service SF, SG, SH", rated SAE 30 weight. Use no special additives. Select the oil's viscosity grade according to your expected operating temperatures.

colder <-----40°F-----> warmer
Synthetic 5W-30 | SAE 30

Although multi-viscosity oils (5W30, 10W30, etc.) improve starting in cold weather, these multi-viscosity oils will result in increased oil consumption when used above 40°F. Check your engine oil level more frequently to avoid possible damage from running low on oil. Oil sump capacity is 20 ounces.

Gasoline

Your pressure washer engine is 4 cycle. Use unleaded fuel only.

▲ CAUTION: Do not overfill the fuel tank. Always allow room for fuel expansion.

▲ WARNING: Never fill fuel tank indoors. To avoid explosion and injury, never fill fuel tank when engine is running or hot. Do not smoke or have open flame when filling fuel tank.

Use clean, fresh, regular unleaded gasoline with a minimum of 85 octane. Do not mix oil with gasoline. If unleaded fuel is unavailable leaded fuel may be used.

IMPORTANT: It is important to prevent gum deposits from forming in essential fuel system parts such as the carburetor, fuel filter, hose or tank during storage. Also, experience indicates that alcohol-blended fuels (called gasohol or using ethanol or methanol) can attract moisture which leads to separation and formation of acids during storage. Acidic gas can damage the fuel system of an engine while in storage. To avoid engine problems, the fuel system should be emptied before storage of 30 days or longer. Never use engine or carburetor cleaner products in the fuel tank or permanent damage may occur.

▲ CAUTION: Never start pressure washer without water source turned on and connected to pressure washer. Failure to do so will cause pump damage.

To Start Your Pressure Washer

- Remove gas cap.
- Add unleaded gasoline, slowly, to fuel tank.
- Do not overfill.

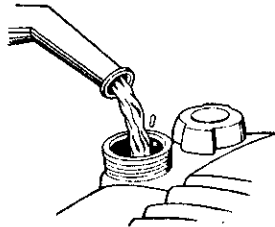

- Connect garden hose to the water inlet on the pressure washer. Tighten by turning counterclockwise.

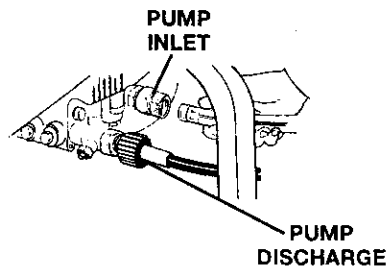

- Connect high pressure hose to discharge on pump.
- Connect the garden hose to the water spout and turn water supply on.

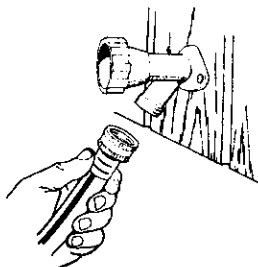

- Squeeze trigger on pressure washer wand to relieve air pressure caused by turning on the water. Water will spew out of the gun in a thin stream. This will make it easier to start the engine.
- Engage the safety latch on the spray gun. This locks the trigger in place and keeps you from accidentally spraying a high pressure stream.

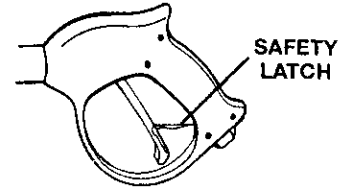

- On the engine there is a choke/run lever. Place lever to the choke position.
- On the engine there is a throttle control lever. Place throttle to the rabbit position. Always start engine with throttle in the rabbit (high speed) position.

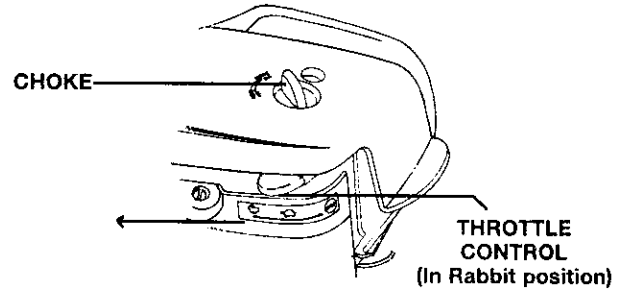

- Grasp the starter grip and pull slowly until resistance is felt, then pull firmly to start engine.

NOTE: If engine does not start right away, squeeze the trigger on the gun to relieve air pressure caused by turning on the water. Water will spew out of the gun in a thin stream. This will make it easier to pull start the engine. If more than five pulls, place choke lever back to run position.

- When engine starts, gradually move choke lever to RUN position.
- For hot engine restarts, make sure throttle is in the rabbit (high speed) position and the choke lever is in the RUN position.
- Grasp the starter grip and pull slowly until resistance is felt, then pull firmly to start engine.

IMPORTANT: This unit is equipped with a thermal relief valve. If unit is allowed to run for several minutes without pressing the trigger on the spray gun, several drops of water may be released through this valve to cool the unit. This small amount of water will drip from the bottom of the pump.

How To Use Your Pressure Washer

Adjusting Chemical Flow

- Turn the knob on the high pressure soap wand to adjust the soap flow. Turn knob counterclockwise for more soap (+) and clockwise for less soap (-).

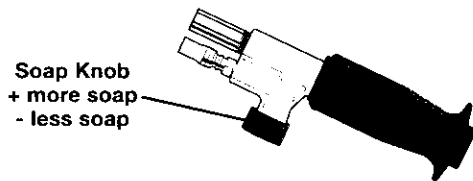

Adjusting Fan Spray

- The nozzle at the end of the high pressure soap wand can be rotated to change the high pressure spray pattern from a narrow jet to a 50° fan shape, as shown.

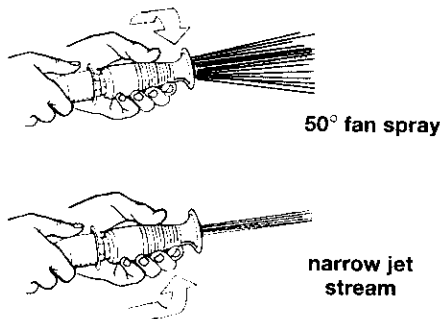

Using Soaps/Chemicals

IMPORTANT: Use soaps and chemicals that are designed specifically for use with pressure washers.

To apply soaps/chemicals follow these steps:

- Prepare the soap/chemical as required for your job.
- Press one end of the clear soap hose (supplied) onto the barb fitting on the high pressure soap wand.
- Place the other end of the soap hose into the container of pressure washer approved cleaning fluid. (soap/chemicals and container not included).

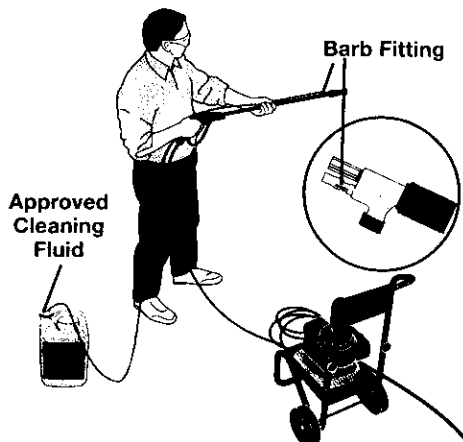

- Start the pressure washer as outlined in the “To Start Your Pressure Washer” paragraph on page 9.

WARNING: Stand on a stable surface and grip gun/wand firmly with both hands. Expect the gun to kick when triggered.

- Depress the trigger on the gun to begin spraying. Release trigger to stop spraying.

CAUTION: DO NOT stop spraying water for more than two minutes at a time. Pump operates in bypass mode when spray gun trigger is not pressed. If pump is left in bypass mode for more than two minutes internal components of the pump can be damaged.

- Adjust the fan spray and soap flow. See Adjusting Chemical Flow and Adjusting Fan Spray.

WARNING: Risk of injection or injury to person. **DO NOT** direct discharge stream toward persons.

- Apply soap/chemicals to dry surface, starting from the bottom and working up.
- Allow the soap/chemicals to soak in between 3-5 minutes before washing and rinsing.
- When rinsing on high pressure, start at lower portion of area to be washed and work upward, using long, even, overlapping strokes.
- After use of chemical, spray clean water through soap hose.

MAINTENANCE

CUSTOMER RESPONSIBILITIES TABLE				
MAINTENANCE TASK	Before each use	Every 25 hours or yearly	Every 50 hours or yearly	Every 100 hours or yearly
PRESSURE WASHER				
Check/clean inlet screen.	x			
Check high pressure hose.	x			
Check soap and chemical hose and filter	x			
Check gun and wand for leaks.	x			
Purge pump of air and contaminants	x			
ENGINE				
Check oil level	x			
Change engine oil			x	
Clean air cleaner and precleaner		x		
Clean/replace spark plug				x
Clean engine muffler & finger guard				x
Prepare for storage	Prepare unit for storage if it is to remain idle for longer than 30 days.			

Product Specifications

Pressure Washer Specifications

Pressure	2400
Flow Rate	2.4 GPM
Cleaning Units (psi x GPM)	5760

Engine Specifications

RPM	3600
Rated Horsepower	6.0
Spark Plug Gap	.030" (0.76mm)
Gasoline Capacity	1.5 quarts
Oil (22 oz. capacity)	SAE 30 weight

General Recommendations

The warranty of the high pressure washer does not cover items that have been subjected to operator abuse or negligence. To receive full value from the warranty, operator must maintain high pressure washer as instructed in this manual.

Some adjustments will need to be made periodically to maintain your high pressure washer.

Once a year you should clean or replace the spark plug, and clean or replace the air filter, and thoroughly check the gun and wand assembly for wear. A clean spark plug and clean air filter assure proper fuel-air mixture and help your engine run better and last longer.

NOTE: Over time the o-rings in the gun assembly become worn. Attached to your owners manual is a replacement o-ring and split backup ring.

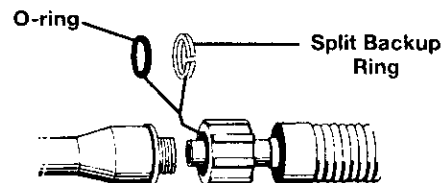

Pressure Washer Maintenance

Check and Clean Inlet Screen: Examine inlet screen on pump inlet fitting. Clean if clogged; replace if torn.

Check High Pressure Hose: High pressure hose can develop leaks from wear, kinking, abuse. Inspect hose each time before use. Check for cuts, leaks, abrasions or bulging of cover, and damage or movement of couplings. If any of these conditions exist, replace hose immediately.

Check Chemical/Soap Hose: Examine the chemical/soap hose and clean if clogged. Hose should fit tightly on pump fitting. Check for leaks and tears. Replace filter or hose if either is damaged.

Check Gun and Wand: Examine hose connection to gun making sure it is secure. Test trigger by pressing it and making sure it springs back into place when you release it.

Pump Maintenance (Changing Pump Oil)

The pump on your pressure washer was shipped from the factory with oil. The oil in your pump must be changed every 50 hours.

- Run engine until it runs out of fuel. Otherwise, fuel can leak out, creating a fire/explosion hazard, when you tip engine.
- Disconnect spark plug wire and keep it away from spark plug.
- Drain engine oil. See **Changing Oil** on page 8.

CAUTION: Used oil is a hazardous waste product. Dispose of used oil properly. Do not discard with household waste. Check with your local authorities for safe disposal/recycling facilities.

- Using a 5/16" Allen wrench remove pump oil drain plug.

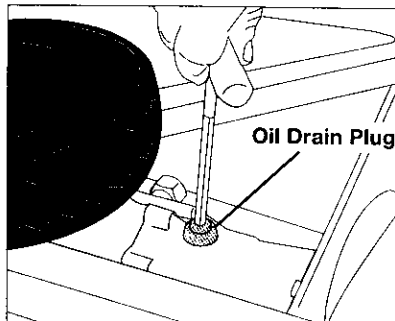

- Tilt unit and drain pump oil into appropriate container.
- Fill pump with 8 ounces of R&O 150 oil. **NOTE:** If unable to find R&O 150 oil, use 30W non-detergent oil.
- Replace oil drain plug and tighten securely.
- Refill engine with oil and fuel. See **Engine Oil** on page 8.

Purge Pump of Air and Contaminants

To remove the air from the pump, follow these steps:

- Set up the pressure washer as described in ASSEMBLY section and connect the water supply.
- Remove the wand extension from the spray gun.
- Pull the trigger on the gun and hold.

To remove the contaminants from the pump, follow these steps:

- Set up the pressure washer as described in ASSEMBLY section, connect the water supply.
- Remove the wand extension from the spray gun.
- Start the engine according to instructions in the OPERATION section.
- Pull the trigger on the gun and hold.
- When the water supply is steady and constant, disengage trigger and refasten the wand extension.

Engine Maintenance

Check Oil Level

- Oil level should be checked prior to each use or at least every 5 hours of operation. To check oil see **Engine Oil** on page 8.

Changing Engine Oil

- Change oil while engine is still warm. Preferably drain oil from top of engine as illustrated below. Drain oil with air cleaner side up. Oil can be drained from engine bottom if necessary.

IMPORTANT: Before tipping engine or equipment to drain oil, drain fuel from tank by running engine until fuel tank is empty.

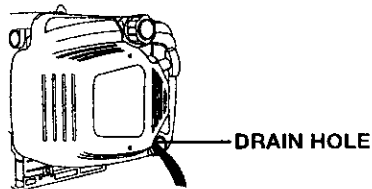

- To drain oil from bottom of engine, remove drain plug as illustrated below. Allow oil to drain and replace drain plug. Remove dipstick and refill with new oil of recommended grade. Start and run engine at idle for 30 seconds.

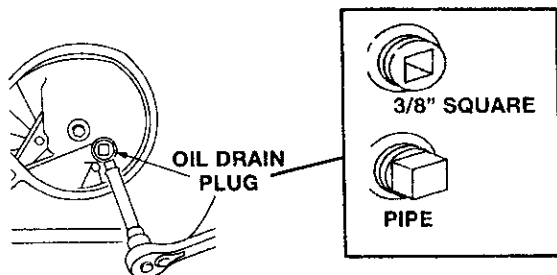

- Stop engine. Wait 30 seconds and recheck oil level. If required, add oil to bring level to FULL mark on dipstick.

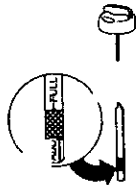

Check Engine – Finger Guard/Muffler

- Do not clean engine with a forceful spray of water because water could contaminate fuel system. With a brush or cloth, clean any debris from finger guard after every use to prevent engine damage caused by overheating.

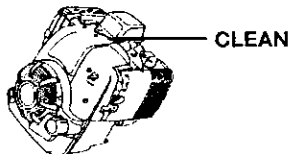

- Before running engine, clean muffler area to remove all grass and combustible debris.

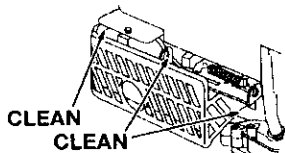

Clean Pre-Cleaner and Air Cleaner Cartridge

Your engine is equipped with an oval dual element air cleaner: the two elements include a foam pre-cleaner and an air cleaner cartridge.

- To remove the air cleaner element, loosen two cover screws and lift cover. Carefully remove foam pre-cleaner and air cleaner cartridge.
- To clean pre-cleaner and air cleaner cartridge, wash in liquid detergent and water. Allow to dry thoroughly before using. Do not oil the pre-cleaner or cartridge. Replace if very dirty or damaged.
- After cleaning the pre-cleaner and air cleaner cartridge, replace pre-cleaner on air cleaner cartridge.
- Install air cleaner assembly (pre-cleaner and cartridge) in base. Then install cover on air cleaner and tighten screws securely to base.

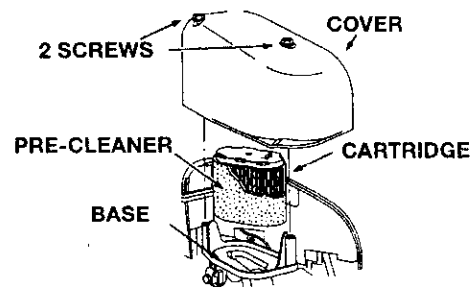

NOTE: Do not use petroleum solvents, e.g., kerosene, which will cause the cartridge to deteriorate. Do not use pressurized air to clean cartridge. Pressurized air can damage the cartridge.

Clean and Replace Spark Plug

Change the spark plug every 100 hours of operation or once each year, whichever comes first. This will help your engine to start easier and run better.

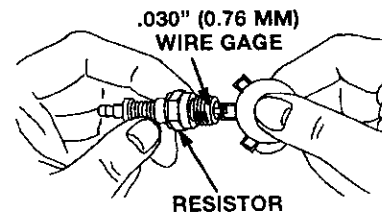

SERVICE AND ADJUSTMENTS

Carburetor

The carburetor of your high pressure washer is pre-set at the factory. The carburetor should not be tampered with. If your pressure washer is used at an altitude in excess of 5000 feet consult with your nearest Sears Service Center regarding high altitude set changes.

CAUTION: Engine speed was properly adjusted at the factory and should require no additional adjustment. Do not attempt to change engine speed. If you believe the engine is running too fast or too slow, take your pressure to a Sears Authorized Service Center for repair and adjustment.

WARNING: High engine speeds are dangerous and increase the risk of personal injury or damage to equipment.

CAUTION: Low engine speeds impose a heavy load on the engine and could shorten engine life.

Nozzle Cleaning

If the nozzle becomes clogged with foreign materials, such as dirt, excessive pressure may develop. If the nozzle becomes partially clogged or restricted, the pump pressure will pulsate. Clean the nozzle immediately using the nozzle kit supplied and the following instructions.

- Shut off the pressure washer and turn off the water supply.
- Disconnect spark plug wire.
- Pull trigger on gun handle to relieve any water pressure.
- Disconnect the wand from the gun.
- Remove nozzle from the end of the wand with the 2mm Allen wrench provided.
- Clean the nozzle using the nozzle cleaner provided or a straightened paper clip. Insert into the nozzle end and work back and forth until obstructions is removed.

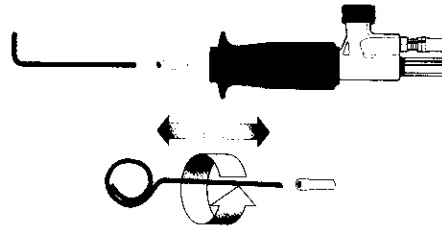

- Direct water supply into nozzle end to backflush loosened particles for 30 seconds.



- Reassemble the nozzle to the wand. Tighten securely to prevent leaks.
- Reconnect wand to gun and turn on water supply.
- Start pressure washer to test.

STORAGE

Preparing Pressure Washer for Storage

NOTE: If you do not plan to use your unit for 30 days or more, unit should be prepared for storage.

IMPORTANT: It is important to prevent gum deposits from forming in essential fuel system parts such as the carburetor, fuel filter, hose or tank during storage. Also, experience indicates that alcohol-blended fuels (called gasohol or using ethanol or methanol) can attract moisture which leads to separation and formation of acids during storage. Acidic gas can damage the fuel system of an engine while in storage. To avoid engine problems, the fuel system should be emptied before storage of 30 days or longer. Never use engine or carburetor cleaner products in the fuel tank or permanent damage may occur.

Engine Preparation

- First add a fuel stabilizer to the fuel tank.
- Run pressure washer for a full 5 minutes to allow fuel stabilizer to enter the fuel system.
- Next shut off engine and disconnect the water supply.
- Disconnect the spark plug wire and remove the spark plug.
- Add one teaspoon of oil through the spark plug hole.
- Place rag over spark plug hole and pull the recoil a few times to lubricate the combustion chamber.
- Replace the spark plug, but do not connect the spark plug wire.

▲ CAUTION: While preparing the engine make sure water supply is turned on and flowing to the unit. **NEVER** run unit without water supply running through pump. Failure to do so will cause pump damage.

Pump Preparation

This pressure washer should be stored in such a way to protect it from freezing. Do not store this unit outdoors or in an area where temperatures will fall below 32° F. This can cause extensive damage to this unit.

NOTE: Antifreeze needs to be added to pump if expecting freezing temperatures or storing for longer than 3 months.

Add antifreeze according to steps below:

- Be sure engine switch is in "OFF" position and spark plug wire has been removed from spark plug.
- Pull the trigger on the spray gun to release the pressure in the high pressure hose. Detach high pressure hose and garden hose from the unit.
- Pull the recoil on the engine 4 to 6 times to discharge remaining water in pump.
- Tip the unit on the end with the water inlet fitting pointing upward.
- If unit will be stored where temperatures fall below 32°F, pour approximately 1/4 cup of non-toxic R.V. antifreeze down the fitting where the water hose attaches to the pump.
- Set unit upright and pull starter handle on engine 4 to 6 times to circulate antifreeze in pump until antifreeze is discharged from the pump.

TROUBLESHOOTING

SYMPTOM	CAUSE	SOLUTION
Engine won't start	<ol style="list-style-type: none"> 1. Engine throttle is in "OFF" Position. 2. Choke lever has not been placed to choke. 3. Pressure buildup after initial use. 	<ol style="list-style-type: none"> 1. Slide throttle to "Run" position. 2. Slide choke lever to choke position. 3. Depress trigger gun.
Won't Draw Chemical	<ol style="list-style-type: none"> 1. Adjustment knob on soap nozzle is turned fully clockwise for less soap (-). 2. Chemical screen is obstructed. 3. Chemical screen not working. 4. Chemical injector orifice obstructed or stuck. 	<ol style="list-style-type: none"> 1. Turn knob counterclockwise for more soap (+). 2. Check chemical screen; clean if obstructed. 3. Make sure chemical screen is submerged in chemical/water. 4. Check and clean.
Pump running normally but pressure does not achieve rated values	<ol style="list-style-type: none"> 1. Water supply restricted. 2. Adjustment knob on soap nozzle is turned fully clockwise for less soap (-). 3. Nozzle incorrect or worn. 4. Pump sucking air. 5. Nozzle blocked. 	<ol style="list-style-type: none"> 1. Check water supply and filter screen for blockage. Check hoses for blockage, kinks, leaks, etc. 2. Turn knob counterclockwise for more soap (+). 3. Check and replace. 4. Check that hoses and fittings are airtight. 5. Clean nozzle.
Fluctuating Pressure	<ol style="list-style-type: none"> 1. Pump sucking air. 2. Garden hose inlet strainer clogged. 3. Worn Seals or Packing. 4. Inadequate water supply. 5. Fouled or dirty inlet or discharge valves. 6. Leaky discharge hose. 	<ol style="list-style-type: none"> 1. Check that hoses and fittings are airtight. Purge air from garden hose. 2. Clean. Check filter frequently. 3. Check and replace. 4. Check hose for kinks. 5. Check flow available to pump. Check for excessive heat, 145° F or above. 6. Clean inlet and discharge valve assemblies. Replace if damaged.
Pressure drops after period of normal use	<ol style="list-style-type: none"> 1. Nozzle clogged, partially obstructed. 2. Nozzle worn. 3. Valves worn, dirty or stuck. 4. Worn piston packing. 	<ol style="list-style-type: none"> 1. Check connection. Replace if cracked or punctured. 2. Clean or replace. 3. Check and replace. 4. Check and replace.
Pump noisy	<ol style="list-style-type: none"> 1. Water too hot. 2. Pump sucking air. 3. Valves dirty or worn. 4. Worn bearings. 	<ol style="list-style-type: none"> 1. Reduce temperature below 63° C or 145° F. 2. Check that hoses and fittings are airtight. 3. Check, clean or replace. 4. Check and replace if necessary.
Presence of water in oil (oil milky);	<ol style="list-style-type: none"> 1. High humidity. 2. Piston packing and oil seal worn. 	<ol style="list-style-type: none"> 1. Change Oil. 2. Check and replace oil seals.
Water dripping from pump	<ol style="list-style-type: none"> 1. Fittings Loose. 2. O-rings of piston guide or retainer worn. 3. Piston packing worn. 	<ol style="list-style-type: none"> 1. Tighten. 2. Check and replace. 3. Check and replace.
Oil Dripping	<ol style="list-style-type: none"> 1. Oil seal worn 2. Loose drain plug or worn drain plug o-ring. 	<ol style="list-style-type: none"> 1. Check and replace 2. Tighten drain plug or replace o-ring. Do not over torque.

PARTS

CRAFTSMAN 2400 PSI HIGH PRESSURE WASHER 919.670280

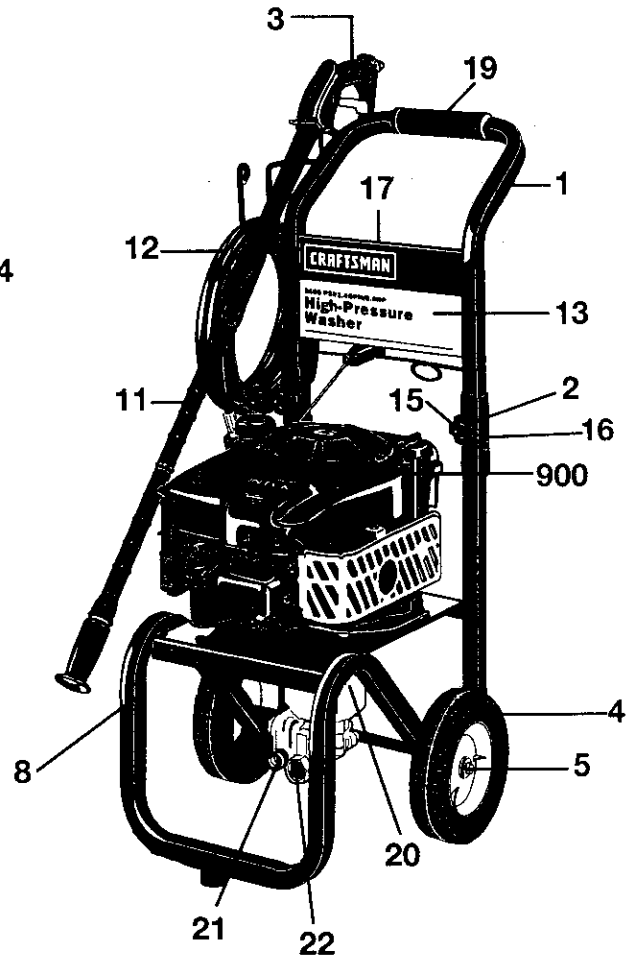
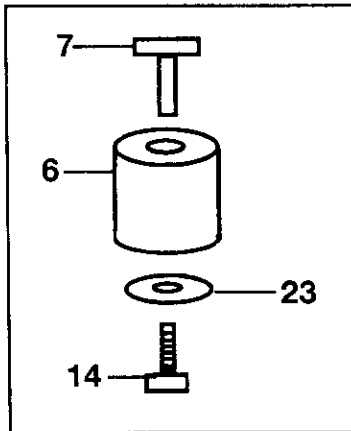
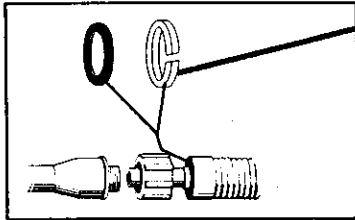
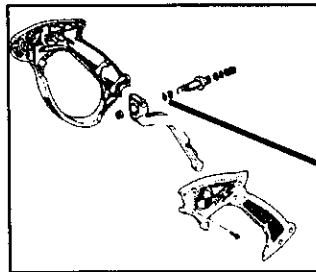

REF NO.	PART NUMBER	DESCRIPTION
1	D20588	Handle, Bagged
2	C042	Knob - 5/16"
3	17628	Gun
4	17709	Tire Semi (8x2")
5	W137	Nut Pal 1/2"
6	17926	Rubber Foot, Hollow
7	W131	Tee Nut 5/160" x 3/4"
8	17713	Frame
11	D20587	Wand, High Pressure Soap
12	D20181	Hose. 1/4" X 25 ft.
13	17569	Decal Craftsman
14	F064	Screw - Hex 5/16" - 18 x 1LG
15	F469	Lock Nut 5/16"
16	17712	Screw HHC, 5/16"
17	17716	Decal Operation
19	17367	Handle Grip
900	-----	Engine (Refer to Engine Break-down (Model 120612-0152-E10))
20	PK18148	Pump
23	F112	Washer
24	AL-650015	O-Ring Kit

PARTS NOT ILLUSTRATED

D20590	Owners Manual
NCT001	Nozzle Cleaning Tool
D20667	2 mm Allen Wrench
16806	5 mm Allen Wrench
F101	Screw, Hex-Engine to Pump
F196	Screw, Hex-Engine to Pump
16087	Nut Flanghead-Engine to Pump
F074	Washer Flat-Engine to Pump
17658	Thermal Relief Valve
C013	Screen, Filter
D20044	Soap Hose

ACCESSORIES
(Not Included with Pressure Washer)

919.76430	Floor/Siding Brush
919.76431	Fixed Brush
919.76450	25Ft. 3/8" high pressure hose
919.76451	50Ft. 3/8" high pressure hose
919.76484	Turbo nozzle

PUMP PARTS

CRAFTSMAN 2400 PSI HIGH PRESSURE WASHER 919.670280

PUMP BREAKDOWN MODEL PK18148

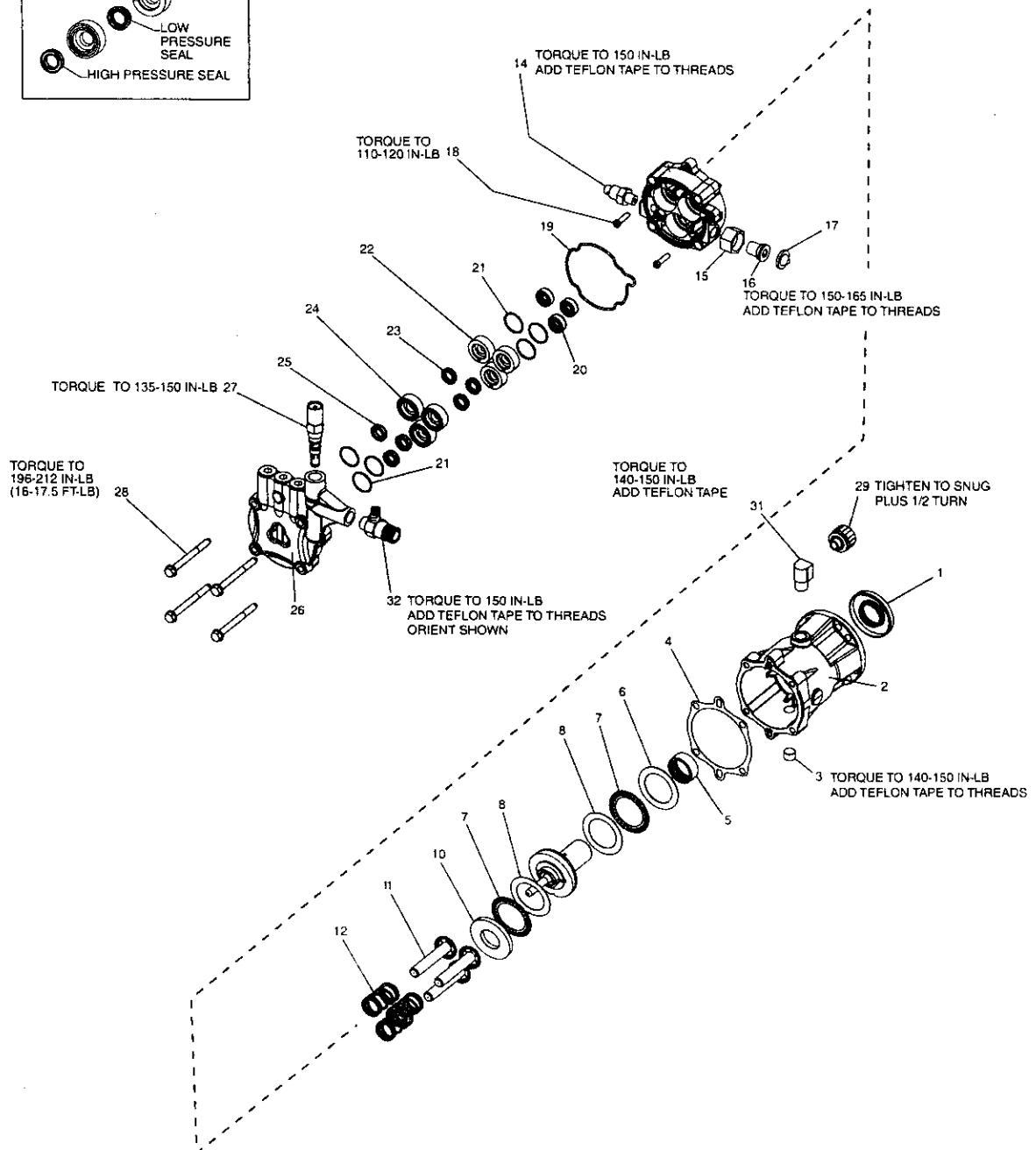
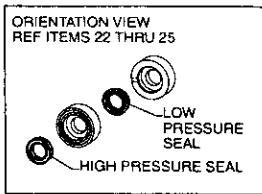
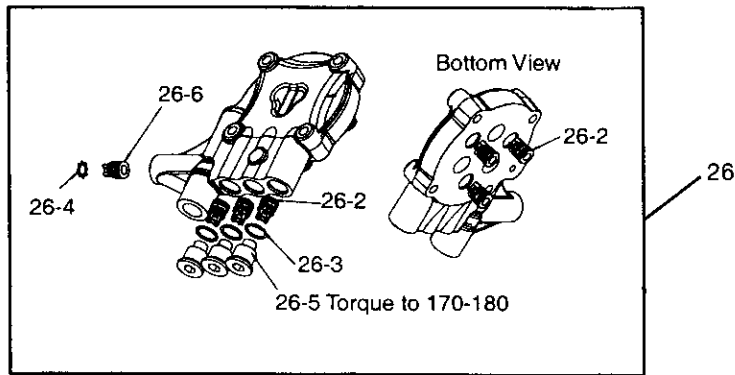

PUMP PARTS

CRAFTSMAN 2400 PSI HIGH PRESSURE WASHER 919.670280

PUMP BREAKDOWN MODEL PK18148

<u>Key#</u>	<u>Part #</u>	<u>Description</u>
1	*	Oil Seal
3	16364	Plug 3/8 NPTF
4	18110	Gasket, Cam Housing
5	*	Bearing Radial Needle
6	*	Thrust Washer (1 used)
7	*	Bearing Thrust (2 used)
8	*	Washer, Thrust (2 used)
10	16301	Washer, Thrust (1 used)
11	16340	Assembly Piston (3 used)
12	16912	Spring Piston (3 used)
16	17701	Swivel, 3/8 NPT
17	F187	Screen
18	16358	Screw, 1/4 -20 x 1 (2 used)
19	16365	O-Ring, Journal Plate (1 used)
20	*	Seal, Piston Oil (3 used)
21	18176	O-Ring, Retainer (6 used)
22	18074	Seal, Retainer (3 used)
23	*	Seal, Leak Back (3 used)
24	18073	Seal, Retainer (3 used)
25	*	Seal, Water (3 used)
26	18143	Head Assembly
26-2	*	Assembly Valve (6 used)
26-3	16360	O-Ring Valve Plug #16 (3 used)
26-4	*	Retaining Ring
26-5	16332	Plug Valve (3 used)
26-6	*	Assembly Valve 45 Degree
27	18139	Unloader
28	18111	Screw, (4 used)
29	16913	Oil Cap
31	F217	Elbow 3/8"
32	V161	Chemical Injector

* Not available as an individual part, order the kit.

Kits available :

18301 Oil Seal Kit, contains Key #s 20 (qty 3), 1 (qty 1), 4 (qty 1)

17323 Valve Kit, contains Key#s 26-2 (qty 6), 26-4 (qty 1), and 26-6 (qty 1).

18246 Water Seal Kit contains Key#'s 25 (qty 3), 23 (qty 3), and 19 (qty 1)

17324 Bearing Kit contains Key #'s 5 (qty 1), 6 (qty 1), 7 (qty 2), 8 (qty 2), and 10 (qty 1)

NOTE: When ordering the bearing kit without the oil seal kit key#4 (18110 gasket) will be needed.

ENGINE PARTS

CRAFTSMAN 2400 PSI HIGH PRESSURE WASHER 919.670280

BRIGGS ENGINE MODEL #120612-0152-E10

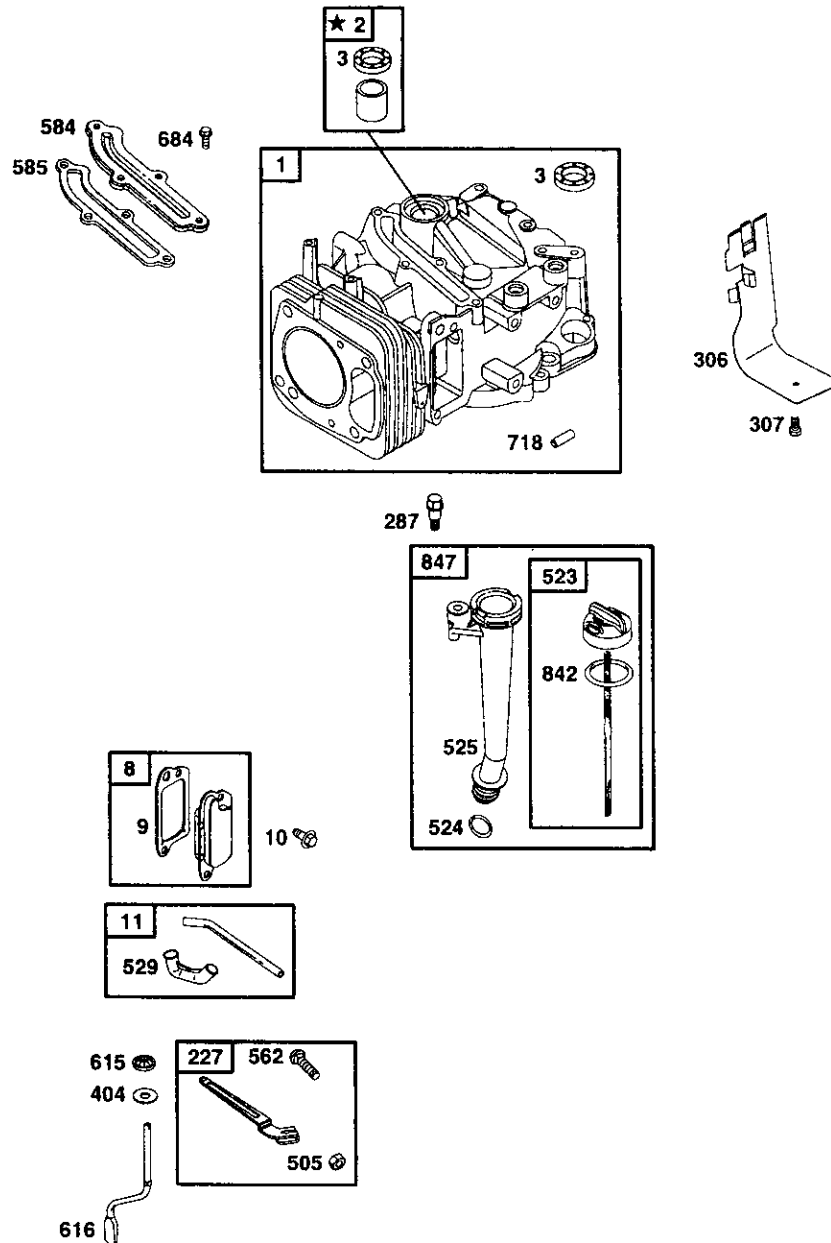

REF NO.	PART NO.	DESCRIPTION	REF NO.	PART NO.	DESCRIPTION	REF NO.	PART NO.	DESCRIPTION
1	692670	Cylinder Assembly	307	690345	Screw (Cylinder Shield)	585	691879	Breather Passage Gasket
2	399269	Bushing/Seal Kit (Magneto Side)	404	690272	Washer (Governor Crank)	615	690340	Governor Shaft Retainer
3	299819	Oil Seal	505	231082	Nut (Governor Control Lever)	616	691306	Governor Crank
8	495786	Breather Assembly	523	499621	Dipstick	684	690345	Screw (Breather Passage Cover)
9	272481	Breather Gasket	524	692296	Dipstick Tube Seal	718	690959	Locating Pin
10	691125	Screw (Breather Assembly)	525	495265	Dipstick Tube	842	691031	Dipstick/Tube Seal
11	499675	Breather Tube	529	692937	Grommet	847	692047	Dipstick/Tube Assembly
227	691467	Governor Control Lever	562	94852	Bolt (Governor Control Lever)			
287	690940	Screw (Dipstick Tube)	584	692342	Breather Passage Cover			
306	691232	Cylinder Shield						

ENGINE PARTS

CRAFTSMAN 2400 PSI HIGH PRESSURE WASHER 919.670280

BRIGGS ENGINE MODEL #120612-0152-E10

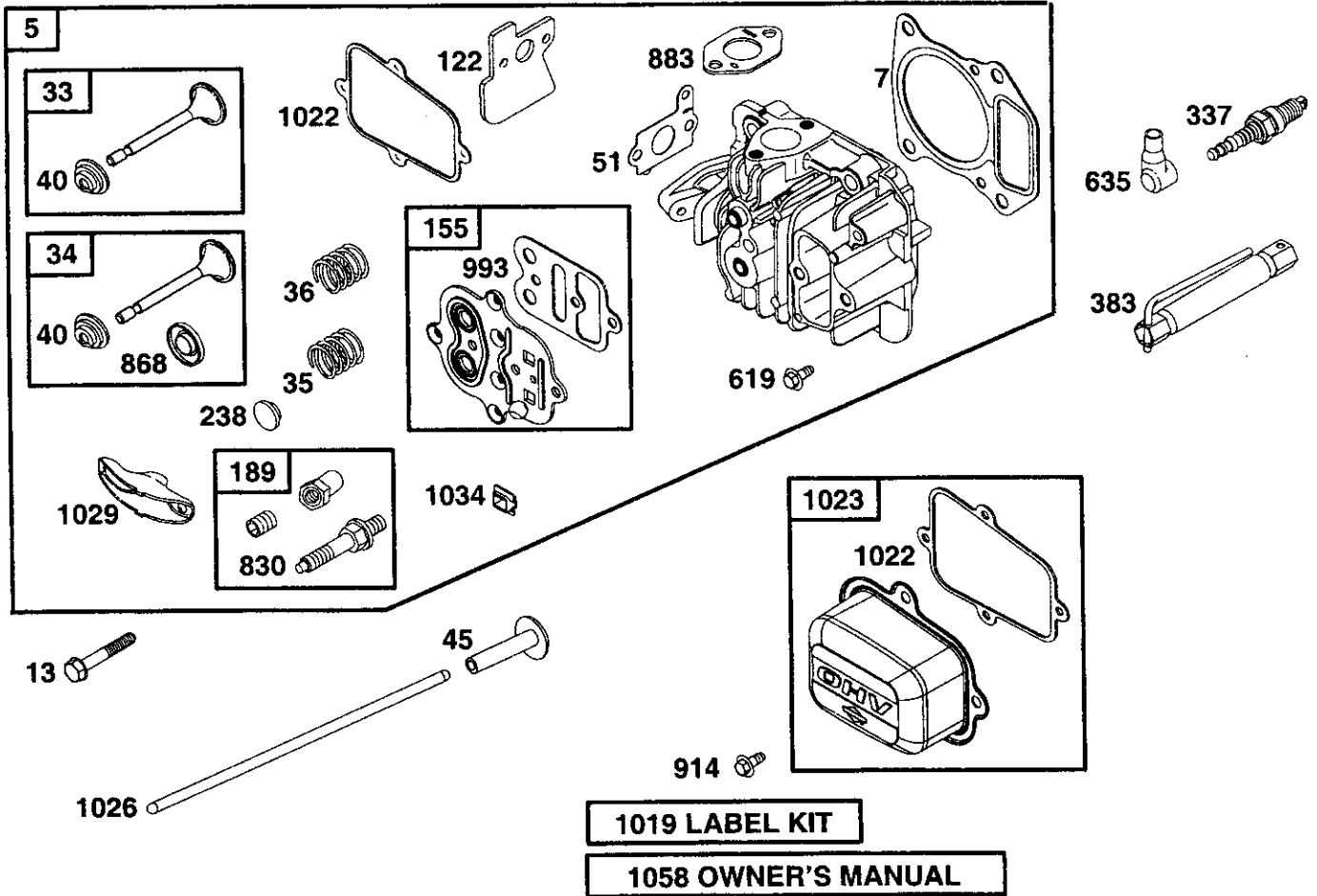

REF NO.	PART NO.	DESCRIPTION	REF NO.	PART NO.	DESCRIPTION	REF NO.	PART NO.	DESCRIPTION
5	695276	Cylinder Head	51	692668	Intake Gasket	883	691893	Exhaust Gasket
7	695166	Cylinder Head Gasket	122	692799	Carburetor Spacer	914	691108	Screw (Rocker Cover)
13	691137	Screw (Cylinder Head)	155	695168	Cylinder Head Plate	993	694088	Cylinder Head Plate Gasket
33	499642	Exhaust Valve	189	694543	Rocker Arm Ball	1019	693868	Label Kit
34	499641	Intake Valve	238	691300	Valve Cap	1022	691890	Rocker Cover Gasket
35	691304	Valve Spring (Intake)	337	692051	Sparkplug	1023	499624	Rocker Arm Cover
36	691304	Valve Spring (Exhaust)	383	19374	Sparkplug Wrench	1026	692045	Push Rod
40	692194	Valve Retainer	619	691108	Screw (Cylinder Head Plate)	1029	691230	Rocker Arm
45	690977	Valve Tappet	635	66538	Sparkplug Boot	1034	691343	Rush Rod Guide
			830	694544	Stud (Rocker Arm)	1058	274264	Owner's Manual
			868	692044	Valve Seal			

ENGINE PARTS

CRAFTSMAN 2400 PSI HIGH PRESSURE WASHER 919.670280

BRIGGS ENGINE MODEL #120612-0152-E10

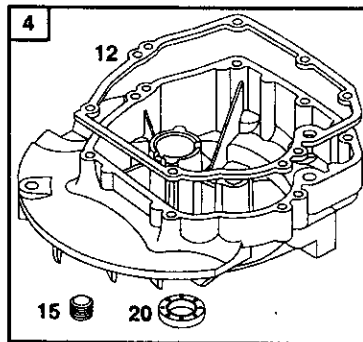
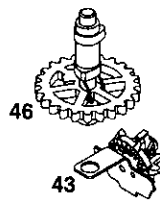
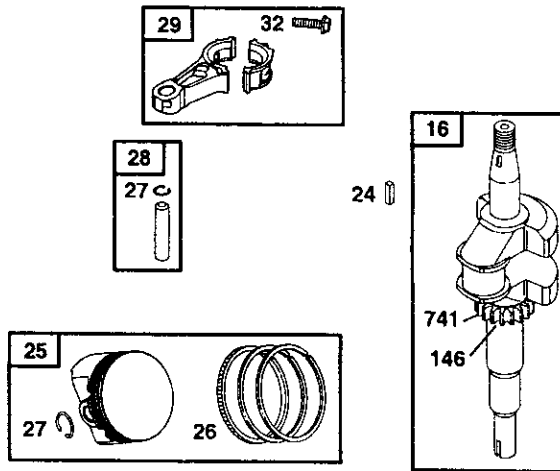

REF NO.	PART NO.	DESCRIPTION	REF NO.	PART NO.	DESCRIPTION
4	499619	Engine Sump	25	694169	Piston Assembly (.030 O.S.)
12	692232	Crankcase Gasket	26	499631	Ring Set (Standard)
15	691680	Oil Drain Plug	26	--- Note ---	
16	695487	Crankshaft	26	692785	Ring Set (.010 O.S.)
20	399781	Oil Seal (PTO Side)	26	692786	Ring Set (.020 O.S.)
22	691092	Screw (Crankcase Cover)	26	692787	Ring Set (.030 O.S.)
24	222698	Flywheel Key	27	691866	Piston Pin Lock
25	690021	Piston Assembly (Standard)	28	499423	Piston Pin
25	--- Note ---		29	499424	Connecting Rod
25	694167	Piston Assembly (.010 O.S.)	32	691664	Screw (Connecting Rod)
25	694168	Piston Assembly (.020 O.S.)	43	691997	Governor/Oil Slinger
			46	694039	Camshaft
			146	690979	Timing Key
			741	691830	Timing Gear

ENGINE PARTS

CRAFTSMAN 2400 PSI HIGH PRESSURE WASHER 919.670280

BRIGGS ENGINE MODEL #120612-0152-E10

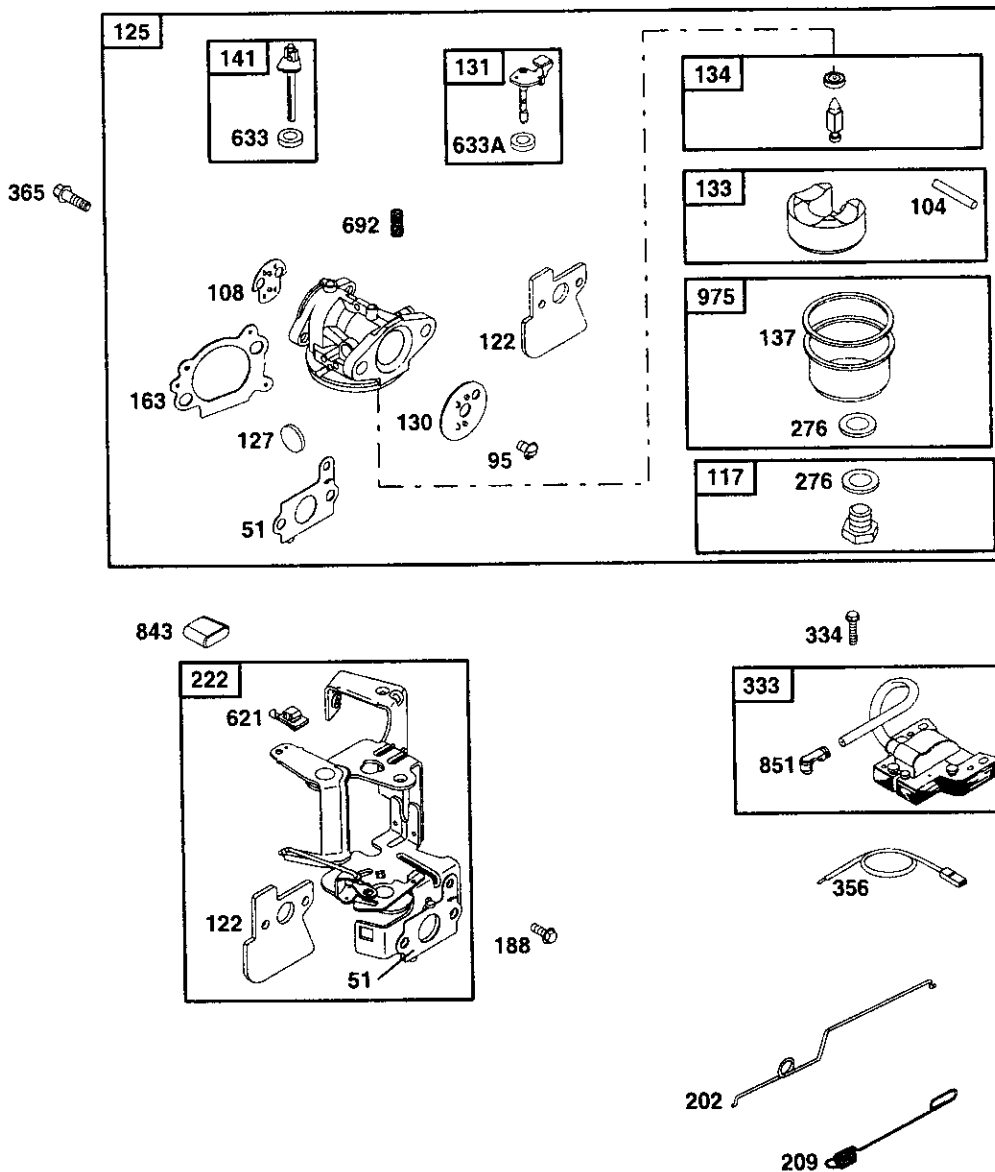

REF NO.	PART NO.	DESCRIPTION	REF NO.	PART NO.	DESCRIPTION	REF NO.	PART NO.	DESCRIPTION
51	692668	Intake Gasket	134	398188	Needle/Seat Kit	365	691136	Screw (Carburetor)
95	691636	Screw (Throttle Valve)	137	693981	Float Bowl Gasket	621	692310	Stop Switch
104	691242	Float Hinge Pin	141	693866	Choke Shaft Kit	633	693867	Choke/Throttle Shaft Seal
108	691182	Choke Valve	163	692667	Air Cleaner Gasket	633A	691321	Choke/Throttle Shaft Seal
117	692677	Main Jet	188	691147	Screw (Control Bracket)	692	690572	Detent Spring
117		--- Note ---	202	691303	Mechanical Governor Link	843	691884	Lever Sleeve
117	497315	Main Jet (High Altitude)	209	691290	Governor Spring	851	493880	Sparkplug Terminal
122	692799	Carburetor Spacer	222	693378	Control Bracket	975	493640	Float Bowl
125	694505	Carburetor	276	271716	Sealing Washer			
127	694468	Welch Plug	333	802574	Magneto Armature			
130	691203	Throttle Valve	334	691061	Screw (Magneto Armature)			
131	499682	Throttle Shaft Kit	356	692390	Stop Wire			
133	398187	Carburetor Float						

ENGINE PARTS

CRAFTSMAN 2400 PSI HIGH PRESSURE WASHER 919.670280

BRIGGS ENGINE MODEL #120612-0152-E10

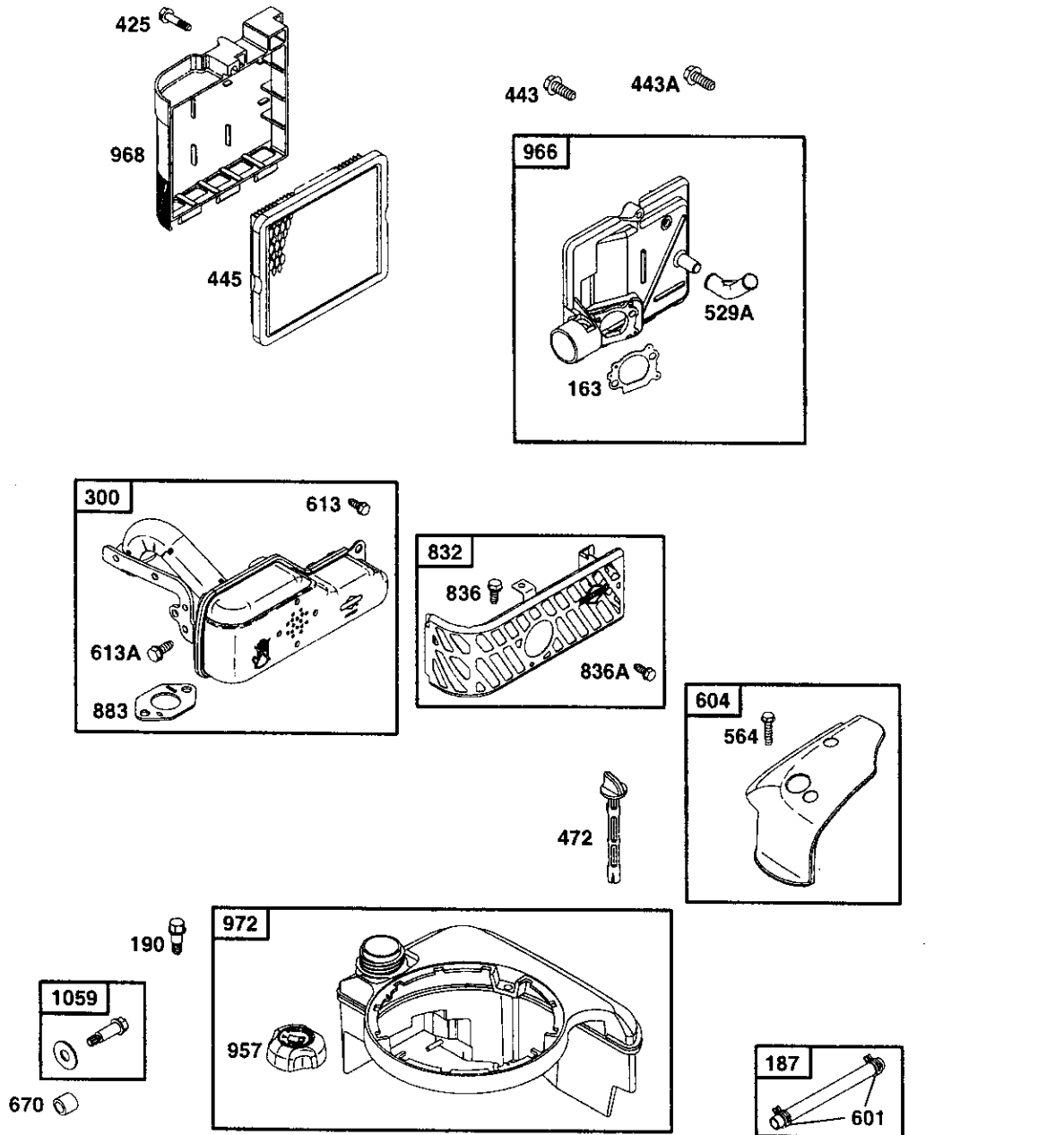

REF NO.	PART NO.	DESCRIPTION	REF NO.	PART NO.	DESCRIPTION	REF NO.	PART NO.	DESCRIPTION
163	692667	Air Cleaner Gasket	445	491588	Air Cleaner Cartridge Filter	832	691466	Muffler Guard
187	691050	Fuel Line	472	693809	Choke Shaft Knob	836	692198	Screw (Muffler Guard)
190	690940	Screw (Fuel Tank)	529A	691923	Grommet	836A	690664	Screw (Muffler Guard)
300	694248	Exhaust Muffler	564	693808	Screw (Air Cleaner Cover)	883	691893	Exhaust Gasket
425	690670	Screw (Air Cleaner Cover)	601	95162	Hose Clamp	957	692046	Fuel Tank Cap
443	691637	Screw (Air Cleaner Primer Base)	604	693807	Control Cover	966	693863	Air Cleaner Primer Base
443A	692523	Screw (Air Cleaner Primer Base)	613	691108	Screw (Exhaust Muffler)	968	692298	Air Cleaner Cover
			613A	691140	Screw (Exhaust Muffler)	972	499618	Fuel Tank
			670	692294	Fuel Tank Spacer	1059	692311	Screw/Washer Kit

ENGINE PARTS

CRAFTSMAN 2400 PSI HIGH PRESSURE WASHER 919.670280

BRIGGS ENGINE MODEL #120612-0152-E10

1036 EMISSIONS LABEL

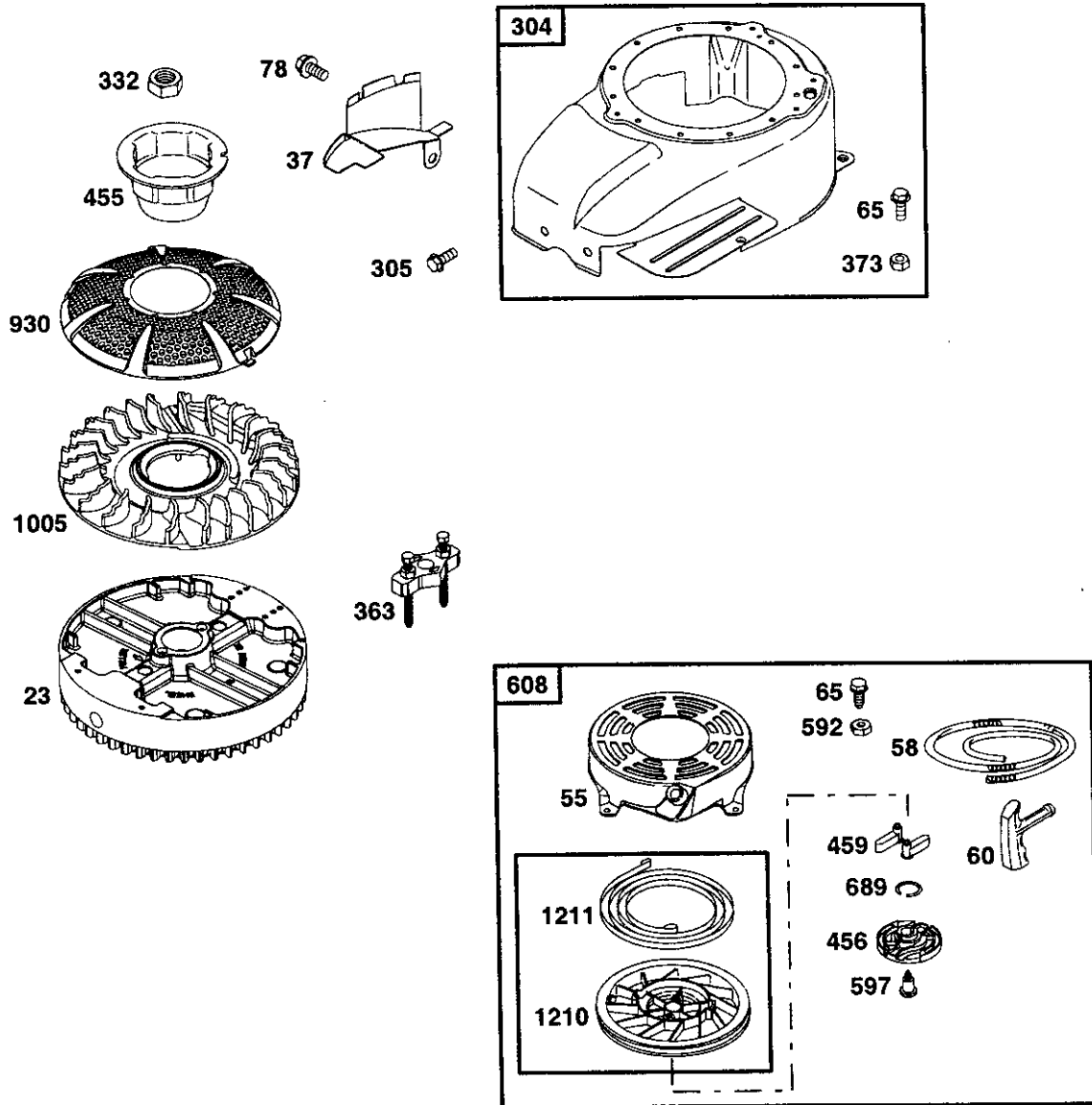

REF NO.	PART NO.	DESCRIPTION	REF NO.	PART NO.	DESCRIPTION	REF NO.	PART NO.	DESCRIPTION
23	692693	Flywheel	304	499676	Blower Housing	689	691855	Friction Spring
37	694086	Flywheel Guard	305	691108	Screw (Blower Housing)	930	692675	Rewind Guard
55	691421	Rewind Starter Housing	332	690662	Nut (Flywheel)	1005	691346	Flywheel Fan
58	693389	Starter Rope (Cut To Required Length)	363	19069	Flywheel Puller	1036	695109	Emissions Label
60	281434	Starter Rope Grip	455	691219	Flywheel Cup	1210	498144	Pulley/Spring Assembly (Pulley)
65	690837	Screw (Rewind Starter)	456	692299	Pawl Friction Plate	1211	498144	Pulley/Spring Assembly (Spring)
78	691108	Screw (Flywheel Guard)	459	281505	Ratchet Pawl			
			592	690800	Nut (Rewind Starter)			
			597	691696	Screw (Pawl Friction Plate)			
			608	497680	Rewind Starter			

ENGINE PARTS

CRAFTSMAN 2400 PSI HIGH PRESSURE WASHER 919.670280

BRIGGS ENGINE MODEL #120612-0152-E10

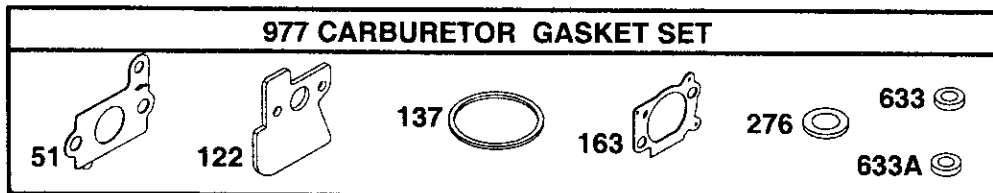
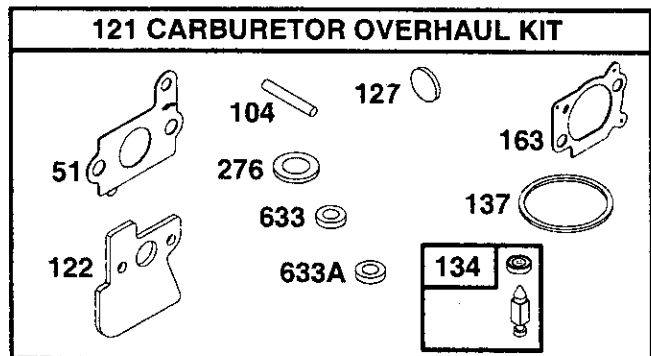
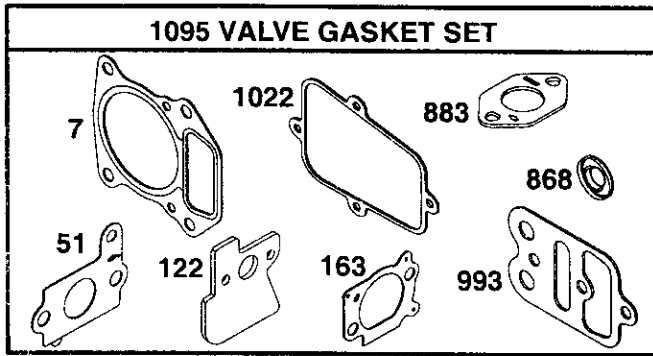
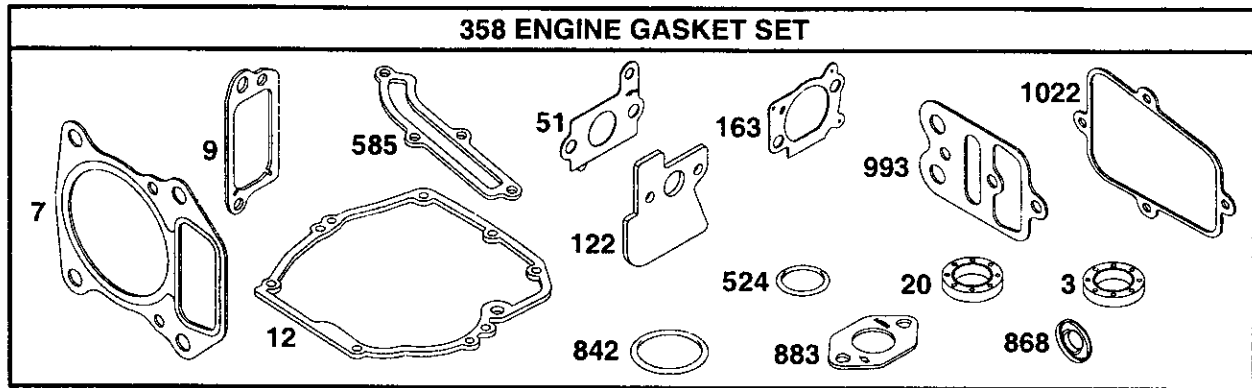

REF NO.	PART NO.	DESCRIPTION	REF NO.	PART NO.	DESCRIPTION	REF NO.	PART NO.	DESCRIPTION
3	299819	Oil Seal	122	692799	Carburetor Spacer	633	693867	Choke/Throttle Shaft Seal
7	695166	Cylinder Head Gasket	127	694468	Welch Plug	633A	691321	Choke/Throttle Shaft Seal
9	272481	Breather Gasket	134	398188	Needle/Seat Kit			
12	692232	Crankcase Gasket	137	693981	Float Bowl Gasket			
20	399781	Oil Seal (PTO Side)	163	692667	Air Cleaner Gasket	842	691031	Dipstick/Tube Seal
51	692668	Intake Gasket	276	271716	Sealing Washer	868	692044	Valve Seal
104	691242	Float Hinge Pin	358	694090	Engine Gasket Set	883	691893	Exhaust Gasket
121	692703	Carburetor Overhaul Kit	524	692296	Dipstick Tube Seal	977	692704	Carburetor Gasket Set
			585	691879	Breather Passage Gasket	993	694088	Cylinder Head Plate

SERVICE NOTES

SEARS

MODEL NO.
919.670280

SERVICE

**HOW TO ORDER
REPAIR PARTS**

OWNER'S MANUAL

The model number of your Sears Air Compressor can be found on the maintenance label on the top of the shroud or on the bar code label on the rear of the air tank.

SERVICE AND REPAIR PARTS CALL 1-800-665-4455*

Keep this number handy should you require a service call or need to order repair parts.

If ordering parts make sure you have the name, make and model no. of the merchandise and the name and number of the part you wish to order.

***If calling locally, please use one of the following numbers:**

Regina -566-5124	Montreal-333-5740
Toronto-744-4900	Halifax -454-2444
Kitchener-894-7590	Ottawa-738-4440
Vancouver - 420-8211	

WHEN ORDERING REPAIR PARTS, ALWAYS GIVE THE FOLLOWING INFORMATION:

- PART NUMBER
- PART DESCRIPTION
- MODEL NUMBER
- NAME OF ITEM

All parts listed may be ordered from any Sears Service Center and most Sears stores.

If the parts you need are not stocked locally, your order will be electronically transmitted to a Sears Repair Parts Distribution Center for handling.

Sold By Sears Canada, Inc., Toronto, Ont. M5B 2B8

Free Manuals Download Website

<http://myh66.com>

<http://usermanuals.us>

<http://www.somanuals.com>

<http://www.4manuals.cc>

<http://www.manual-lib.com>

<http://www.404manual.com>

<http://www.luxmanual.com>

<http://aubethermostatmanual.com>

Golf course search by state

<http://golfingnear.com>

Email search by domain

<http://emailbydomain.com>

Auto manuals search

<http://auto.somanuals.com>

TV manuals search

<http://tv.somanuals.com>