

SEARS

OWNER'S MANUAL

MODEL NO.

390.262454

390.262553

390.262653

CAUTION:

Read and Follow
All Safety Rules and
Operating Instructions
Before First Use of
This Product.

Save This Manual For
Future Reference.



MODEL NOS.

390.262454

390.262553

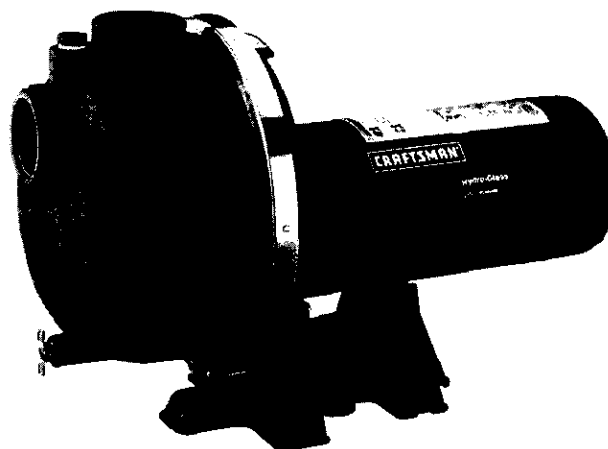

MODEL NO. 390.262653

CRAFTSMAN[®] HYDROGLASS[®] HIGH PRESSURE SPRINKLER PUMP

- Safety Instructions
- Installation
- Electrical
- Maintenance
- Repair Parts

Sears, Roebuck and Co., Hoffman Estates, IL 60179 U.S.A.

CONTENTS

INTRODUCTION/WARRANTY	2
SAFETY	2
PREPARATION	3
INSTALLATION	3-4
ELECTRICAL	5-6
OPERATION	7
MAINTENANCE	8-9
TROUBLESHOOTING	10
REPAIR PARTS	11

INTRODUCTION

Please take a few minutes to read our instructions before you install and use your pump. This will help you obtain the full benefits from this pump. It will also help you avoid any needless service costs that result from causes we cannot control and cannot cover in our warranty.

FULL ONE YEAR WARRANTY ON CRAFTSMAN® SPRINKLER PUMPS

For one year from the date of purchase, Sears will repair or replace this pump, free of charge, if defective in materials or workmanship.

LIMITED WARRANTY ON CRAFTSMAN® HYDROGLASS® SPRINKLER PUMP

After one year and through two years from the date of purchase, Sears will furnish, free of charge, a replacement part for any defective part. You pay for labor.

This warranty does not cover repairs on replacement parts necessary because of abuse or negligence including failure to install, adjust and operate this pump according to the instructions in the owner's manual.

LIMITATION OF LIABILITY

SEARS WILL NOT BE LIABLE FOR LOSS OR DAMAGE TO PROPERTY OR ANY INCIDENTAL OR CONSEQUENTIAL LOSS OR EXPENSE FROM PROPERTY DAMAGE DUE DIRECTLY OR INDIRECTLY FROM THE USE OF THIS PRODUCT.

Some states do not allow the exclusion or limitation of incidental or consequential damages, so the above limitation or exclusion may not apply to you.

WARRANTY SERVICE IS AVAILABLE BY SIMPLY CONTACTING THE NEAREST SEARS SERVICE CENTER/DEPARTMENT IN THE UNITED STATES.

This warranty applies only while the product is in the United States.

This warranty gives you specific legal rights, and you may also have other rights which vary from state to state.

Sears, Roebuck and Co., Dept. 817 WA, Hoffman Estates, IL 60179

RULES FOR SAFE INSTALLATION AND OPERATION!

Carefully read and follow all safety instructions in this manual or on pump.

▲ This is the safety alert symbol. When you see this symbol on your pump or in this manual, look for one of the following signal words and be alert to the potential for personal injury!

▲ DANGER DANGER warns about hazards that will cause serious personal injury, death or major property damage if ignored.

▲ WARNING WARNING warns about hazards that can cause serious personal injury, death or major property damage if ignored.

▲ CAUTION CAUTION warns about hazards that will or can cause minor personal injury or property damage if ignored.

The word **NOTICE** indicates special instructions which are important but not related to hazards.

1. To avoid risk of serious bodily injury and property damage, read safety instructions carefully before installing pump.

2. Follow local and/or national plumbing and electrical codes when installing pump.

3. Keep the well covered while installing pump to prevent leaves and other debris from falling into well, contaminating well and possibly damaging pump.

4. Protect pump and piping system from freezing. Allowing pump or water system to freeze could severely damage pump and voids warranty.

▲ WARNING Hazardous Voltage. Can shock, burn, cause death, or start fires.

5. Disconnect electrical power source before installing or working on pump.

6. Ground pump with a ground wire run from grounding lug on motor to a grounded lead in the service panel.

7. Line voltage and frequency of electrical power supply must agree with motor nameplate.

8. Use of fuses or wire smaller than size recommended in owner's manual can cause overheating, possible fires, and will void warranty.

9. Pump water only with this pump.

10. Do not run pump dry. To do so will damage seals and can cause leaking and property damage.

PREPARATION

BASIC TOOLS AND MATERIALS NEEDED

Pipe Wrenches	Screwdriver
Hacksaw	Check Valve
Adjustable Wrench	Teflon Tape
Knife	

NOTICE: Depth to water must not be more than 20'.

1. Long runs and many fittings increase friction and reduce flow. Locate pump as close to water source as possible; use as few elbows and fittings as possible.
2. Be sure water is clear of sand. Sand will plug the pump and void the warranty.
3. Protect pump and all piping from freezing. Freezing will split pipe, damage pump and void the warranty. Check locally for frost protection requirements (usually pipe must be 12" below frost line and pump must be insulated).
4. Be sure all pipes and foot valve are clean and in good shape.
5. No air pockets in suction pipe.
6. No leaks in suction pipe. Use Teflon tape or Plasto-Joint Stik' to seal pipe joints.
7. Unions installed near pump and water source will aid in servicing. Leave room to use wrenches.
8. **⚠ WARNING** Pump body may explode if used as a booster pump. DO NOT use in a booster application.

¹ Lake Chemical Co., Chicago, Illinois.

INSTALLATION

NOTICE: Use the installation method below which matches your well type.

CASED WELL INSTALLATION

1. Inspect foot valve to be sure it works freely. Inspect strainer to be sure it is clean.
2. Connect foot valve and strainer to the first length of suction pipe and lower pipe into well. Add sections of pipe as needed, using Teflon tape on male threads. Be sure that all suction pipe is leakproof or pump will lose prime and fail to pump. Install foot valve 10 to 20 feet below the lowest level to which water will drop while pump is operating (pumping water level). Your well driller can furnish this information.
3. To prevent sand and sediment from entering the pumping system, the foot valve/strainer should be at least 5 feet above the bottom of the well.
4. When the proper depth is reached, install a sanitary well seal over the pipe and in the well casing. Tighten the bolts to seal the casing.
5. When using a foot valve, a priming tee and plug as shown in Figure 1 are recommended.

DUG WELL OR OPEN WATER INSTALLATION

1. Follow cased well installation, steps 1, 2, 3 and 5.

INSTALLATION (Continued)

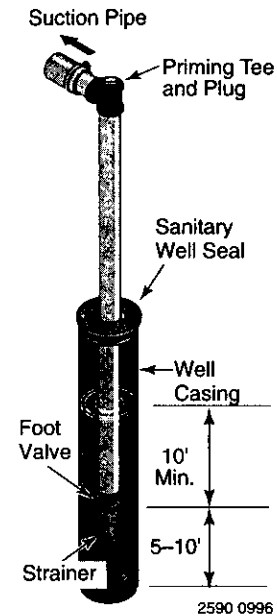

Figure 1 – Cased/Dug Well Installation

DRIVEN POINT INSTALLATION

1. Connect the suction pipe to the drive point as illustrated in Figure 2. Keep horizontal pipe run as short as possible. Use Teflon tape on male pipe threads. Multiple well points may be necessary to provide sufficient water to pump.
2. Install a check valve in piping as shown in Figure 2. Flow arrow on check valve must point toward pump.

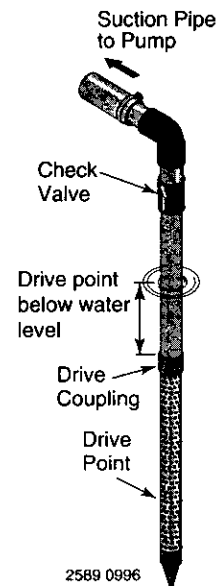

Figure 2 – Driven Point Installation

HORIZONTAL PIPING FROM WELL TO PUMP

1. Never install a suction pipe that is smaller than the suction tapping of the pump.

INSTALLATION (Continued)

- To aid priming on driven point installations, install a line check valve as shown in Figure 2. Be sure check valve flow arrow points toward pump.

DISCHARGE PIPE SIZES

- If increasing discharge pipe size, install reducer in pump discharge tapping. Do not increase pipe size by stages.
- When the pump is set away from the points of water use, the discharge pipe size should be increased to reduce pressure losses caused by friction.
 - Up to 100' run: Same size as pump discharge tapping.
 - 100' to 300' run: Increase one pipe size.
 - 300' to 600' run: Increase two pipe sizes.

LAWN SPRINKLING APPLICATION

This pump is designed for lawn sprinkling. It is designed to deliver plenty of water at full sprinkler pressure. It can pump from a pond, cistern or well points.

Pump discharge can be divided to supply two (2) or more

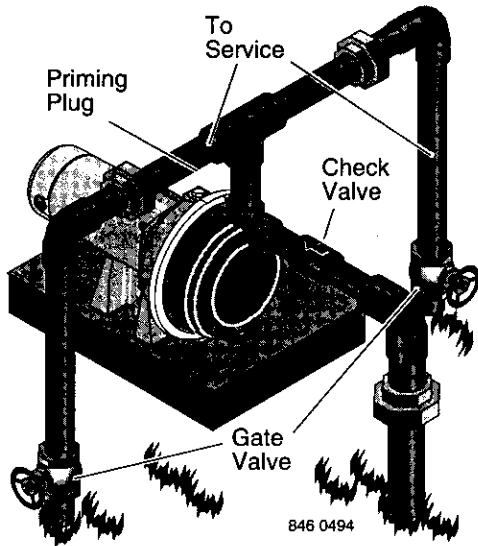

Figure 3 – Multiple Discharge

sprinkler systems. A suggested multiple discharge to service is shown in Figure 3.

Do not use in a pressure tank or booster pump application.

Pump/Piping Installation

PUMP INSTALLATION

NOTICE: Use Teflon tape supplied with the pump for making all threaded connections to the pump itself. **Do not use pipe joint compounds on the pump;** they can react with the plastic in the pump components.

- Bolt pump to solid, level foundation.
- Support all piping connected to the pump.
- Wrap 1-1/2 to two layers of Teflon tape clockwise (as you face end of pipe) on all male threads being attached to pump.
- Tighten joints hand tight plus 1-1/2 turns. **Do not over-tighten.**

NOTICE: Install pump as close to water source as possible. Long piping runs and many fittings create friction and reduce flow.

Use schedule 80 or iron pipe. See "Well Pipe Installation" for more information.

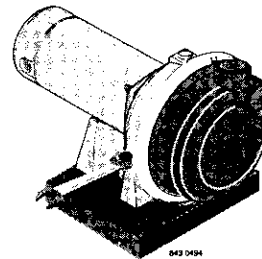

Figure 4 – Bolt Pump Down

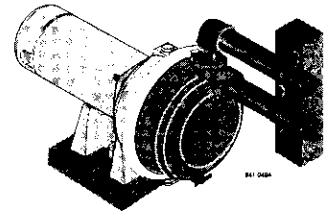

Figure 5 – Independently Support All Piping Attached To Pump

TABLE II – PERFORMANCE CHART (IN GALLONS PER MINUTE)

DISCHARGE PRESSURE PSI	390.262454 1 H.P.				390.262553 1-1/2 H.P.				390.262653 2 H.P.			
	DISTANCE ABOVE TO WATER											
	5'	10'	15'	20'	5'	10'	15'	20'	5'	10'	15'	20'
10	55	49	48	45	67	61	56	46	69	67	65	62
15	51	46	45	44	66	58	55	45	65	63	60	58
20	45	42	39	37	61	56	54	44	59	56	54	52
25	38	35	32	29	55	52	51	43	52	50	48	45
30	31	28	24	20	48	45	44	37	47	45	42	40
35	23	19	16	11	39	37	34	28	42	38	35	32
40	17	13	8	–	33	27	20	11	34	30	27	23
45	–	–	–	–	18	14	8	–	25	18	13	10
50	–	–	–	–	–	–	–	–	14	7	–	–
DISCHARGE PIPE TAPPING	1-1/2" NPT				1-1/2" NPT				2" NPT			
SUCTION PIPE TAPPING	1-1/2" NPT				1-1/2" NPT				2" NPT			

ELECTRICAL

Connection diagram for dual voltage, single-phase motors. Your dual-voltage motor's terminal board (under the motor end cover) will match one of the diagrams below. Follow that diagram if necessary to convert motor to 115 Volt power.

Connect power supply wires to L1 and L2. For 3-phase motors, or if motor does not match these pictures, follow the connection diagram on the motor nameplate.

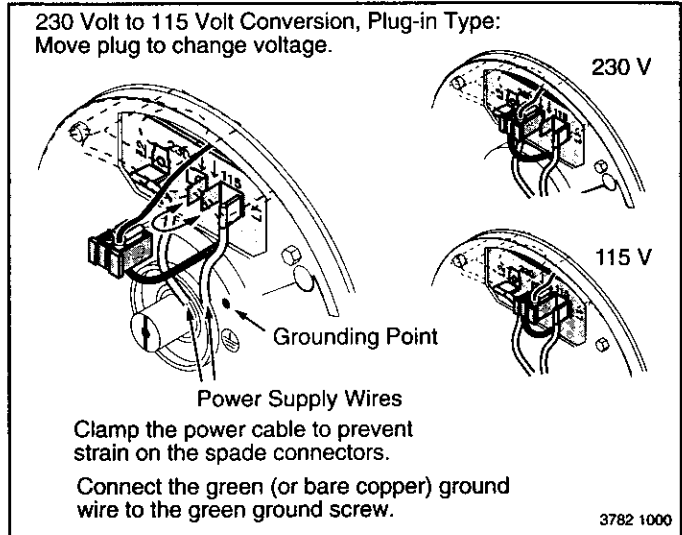
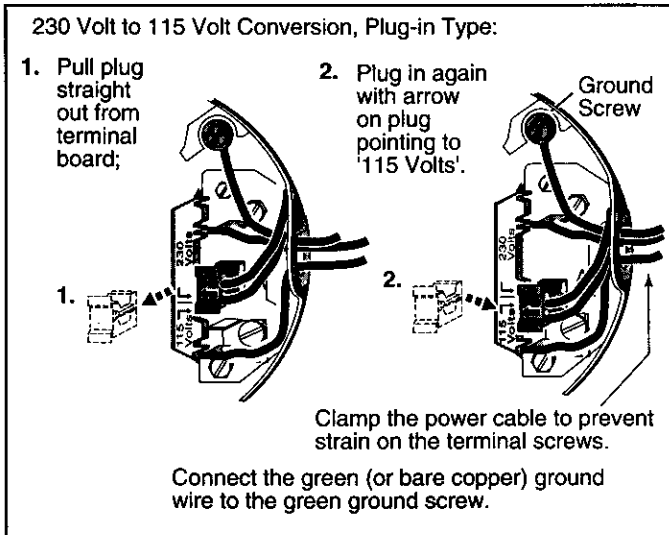

Figure 6 – 115/230V Dual Voltage Single Phase Wiring Diagram.

⚠ WARNING Hazardous voltage. Can shock, burn, or cause death. Disconnect power to motor before working on pump or motor. Ground motor before connecting to power supply.

WIRING

⚠ Ground motor before connecting to electrical power supply. Failure to ground motor can cause severe or fatal electrical shock hazard.

⚠ Do not ground to a gas supply line.

⚠ To avoid dangerous or fatal electrical shock, turn OFF power to motor before working on electrical connections.

⚠ Supply voltage must be within $\pm 10\%$ of nameplate voltage. Incorrect voltage can cause fire or damage motor and voids warranty. If in doubt consult a licensed electrician.

⚠ Use wire size specified in Wiring Chart (Page 6). If possible, connect pump to a separate branch circuit with no other appliances on it.

⚠ Wire motor according to diagram on motor nameplate. If nameplate diagram differs from diagrams above, follow nameplate diagram.

1. Install, ground, wire and maintain this pump in accordance with electrical code requirements. Consult your local building inspector for information about codes.
2. Provide a correctly fused disconnect switch for protection while working on motor. Consult local or national electrical codes for switch requirements.

ELECTRICAL (Continued)

3. Disconnect power before servicing motor or pump. If the disconnect switch is out of sight of pump, lock it open and tag it to prevent unexpected power application.
4. Ground the pump permanently using a wire of the same size as that specified in wiring chart (below). Make ground connection to green grounding terminal under motor canopy marked GRD. or ⊕.
5. Connect ground wire to a grounded lead in the service panel or to a metal underground water pipe or well casing at least 10 feet long. Do not connect to plastic pipe or insulated fittings.
6. Protect current carrying and grounding conductors from cuts, grease, heat, oil, and chemicals.
7. Connect current carrying conductors to terminals L1 and L2 under motor canopy. When replacing motor, check

wiring diagram on motor nameplate against Figure 6. If the motor wiring diagram does not match the diagrams in Figure 6, follow the diagram on the motor.

IMPORTANT: 115/230 Volt single phase models are shipped from factory with motor wired for 230 volts. If power supply is 115 volts, remove motor canopy and re-connect motor as shown in Figure 6. Do not try to run motor as received on 115 volt current.

8. Motor has automatic internal thermal overload protection. If motor has stopped for unknown reasons, thermal overload may restart it unexpectedly, which could cause injury or property damage. Disconnect power before servicing motor.
9. If this procedure or the wiring diagrams are confusing, consult a licensed electrician.

WIRING CHART
Recommended Wire and Fuse Sizes

Pump Model	HP	Volt	Max. Load Amps	Branch Fuse* Rating* Amps	Min. Wire Size	DISTANCE IN FEET FROM MOTOR TO METER					
						0' TO 50'	51' TO 100'	101' TO 200'	201' TO 300'	301' TO 400'	401' TO 500'
						WIRE SIZE					
390.262454	1	115	14.2	20	12	12	12	8	6	6	4
		230	7.6	15	14	14	14	14	14	12	10
390.262553	1-1/2	115	19.2	25	10	10	10	8	6	4	4
		230	9.6	15	14	14	14	14	12	10	10
390.262653	2	230	12.0	15	14	14	14	14	12	10	10

*Dual element or Fusetron time delay fuses recommended for all motor circuits.

OPERATION

PRIMING THE PUMP

NOTICE: 'Priming' refers to the pump expelling all air in the system and beginning to move water from its source out into the system. It does not refer only to pouring water into the pump (although pouring water in is usually the first step).

NOTICE: NEVER run pump dry. Running pump without water in it will damage seals and can melt impeller and diffuser. To prevent damage, fill pump with water before starting.

1. Remove priming plug (Figure 7).

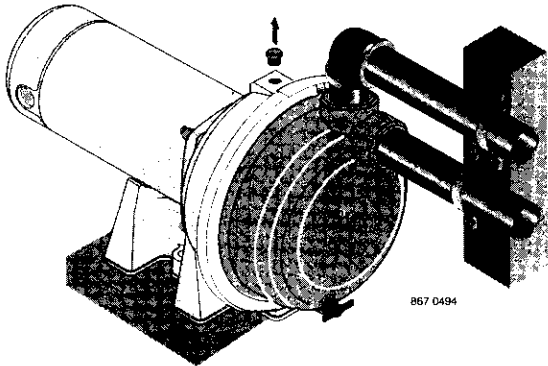

Figure 7 – Remove Priming Plug

2. Make sure suction and discharge valves and any hoses on discharge side of pump are open.
3. Fill pump and suction pipe with water.

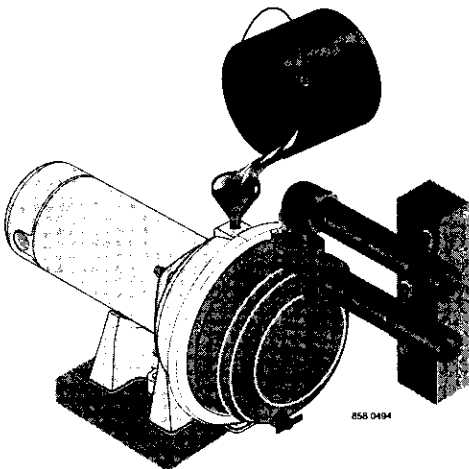

Figure 8 – Fill Pump Before Starting

4. Replace priming plug, using Teflon tape on thread; tighten plug.

NOTICE: If a priming tee and plug have been provided for a long horizontal run, be sure to fill suction pipe through this tee and replace plug. (Don't forget to Teflon tape the plug.)

5. Start pump: water should be produced in 10 minutes or less, the time depending on depth to water (not more than 20') and length of horizontal run (10' of horizontal suction pipe = 1' of vertical lift due to friction losses in the pipe).

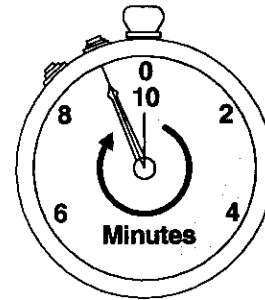

Figure 9 – Run Ten Minutes Or Less

If no water is produced within 10 minutes, stop pump, release all pressure, remove priming plug, refill and try again.

WARNING Hazardous pressure and risk of explosion and scalding. If pump is run continuously at no flow (that is, with discharge shut off or without priming), water may boil in pump and piping system. Under steam pressure, pipes may rupture, blow off of fittings or blow out of pump ports and scald anyone near.

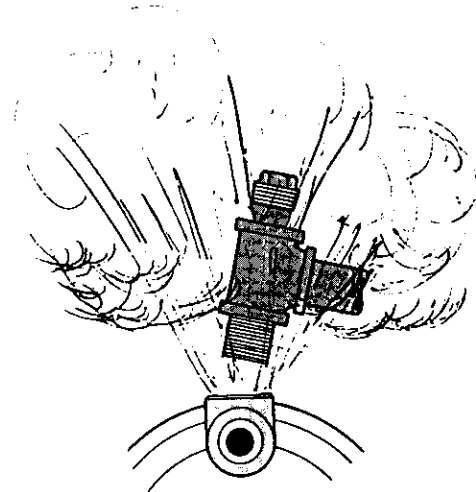

Figure 10 – Do Not Run Pump With Discharge Shut Off

To prevent explosion, do the following:

- A. Be sure discharge (valve, pistol grip hose nozzle, etc.) is open whenever pump is running.
- B. If pump fails to produce water when attempting to prime, release all pressure, drain pump and refill with cold water after every two attempts.
- C. When priming, monitor pump and piping temperature. If pump or piping begin to feel warm to the touch, shut off pump and allow system to cool off. Release all pressure in system and refill pump and piping with cold water.

MAINTENANCE

Pump and piping need not be disconnected to repair or replace motor or seal (see Figure 12). If motor is replaced, replace the shaft seal (Key No. 6, Page 11). Keep one on hand for future use.

Be sure to prime pump before starting.

NOTICE: Check motor label for lubrication instructions. The mechanical shaft seal in the pump is water lubricated and self-adjusting.

NOTICE: Drain pump when disconnecting from service or when it might freeze.

PUMP DISASSEMBLY

1. Disconnect power to motor.

NOTICE: Mark wires for correct assembly.

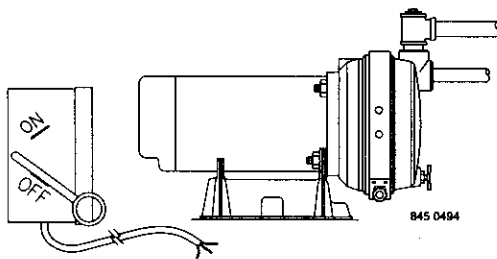

Figure 11 – Disconnect Power

2. Remove clamp (see Figure 12).
3. Remove pump base mounting bolts. Motor assembly and back half of pump can now be pulled away from pump front half (Figure 12). CAREFULLY remove O-Ring.

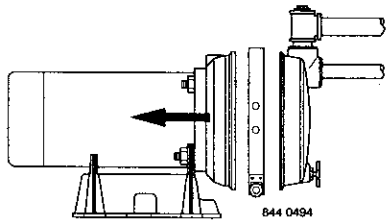

Figure 12 – Slide Motor Back

CLEANING/REPLACING IMPELLER

NOTICE: First, follow instructions under “Pump Disassembly”.

1. Remove four screws fastening diffuser to seal plate; remove diffuser (see Figure 13). Exposed impeller can now be cleaned.

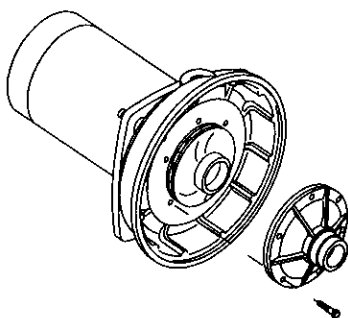

Figure 13 – Remove Diffuser

2. If impeller must be replaced, loosen two machine screws and remove motor canopy (see Figure 14).

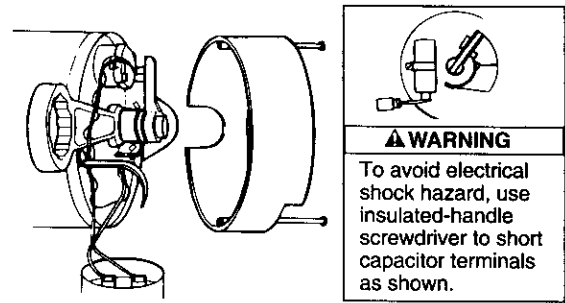

Figure 14 – Hold Shaft

3. **WARNING** Capacitor voltage may be hazardous. To discharge capacitor, hold insulated handle screwdriver **BY THE HANDLE** and short capacitor terminals together (see Figure 14). Do not touch metal screwdriver blade or capacitor terminals. If in doubt, consult a qualified electrician.
4. Unscrew capacitor clamp and remove capacitor. Do not disconnect capacitor wires to motor.
5. Slide 7/16” open end wrench in behind spring loaded switch on motor end of shaft; hold motor shaft with wrench on shaft flats and unscrew impeller by turning counterclockwise when looking into eye of impeller.
6. To reinstall, reverse steps 1 through 5.
7. See directions under “Pump Reassembly,” Page 10.

REMOVING OLD SEAL

1. Follow instructions under “Pump Disassembly”.
2. Follow steps 2 through 5 under “Cleaning/Replacing Impeller”.
3. Unscrew four nuts holding pump back half to motor. Remove rotating half of seal by placing two screwdrivers under back half of pump body and carefully prying up (Figure 15). Back half of pump body will slide off shaft, bringing seal with it.

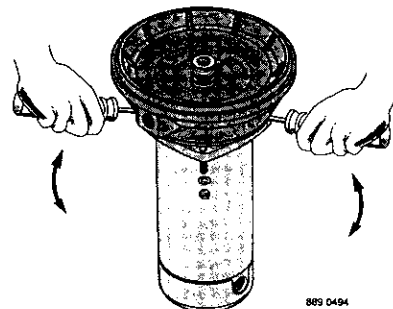

Figure 15 – Remove Seal plate

NOTICE: Be sure you do not scratch or mar shaft; if shaft is marred, it must be dressed smooth with fine emery or crocus cloth before installing new seal. **DO NOT** reduce shaft diameter!

MAINTENANCE (Continued)

- Place pump body half face down on flat surface and tap out stationary half of seal (see Figure 16).

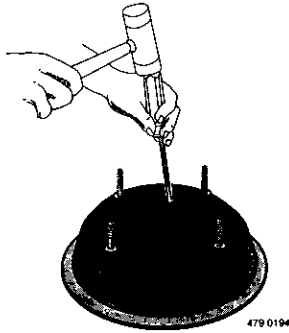

Figure 16 – Tap Out Seal

INSTALLING NEW SEAL

- Wet outer edge of Rubber Cup on ceramic seat with liquid soap. Be sparing!
- Put clean cardboard washer on seal face. With thumb pressure, press ceramic seal half firmly and squarely into seal cavity in seal plate (see Figure 17). Polished face of ceramic seat is up. If seal will not seat correctly, remove, placing seal **face up** on bench. Reclean cavity. Seal should now seat correctly.

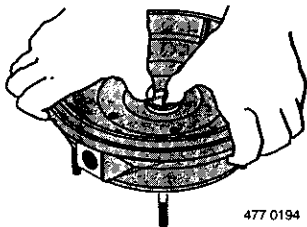

Figure 17 – Press in New Seal

- If seal does not seat correctly after recleaning cavity, place cardboard washer over polished seal face and **carefully** press into place using a piece of standard 3/4" pipe as a press.

NOTICE: Be sure you do not scratch seal face.

- Dispose of cardboard washer and recheck seal face to be sure it is free of dirt, foreign particles, scratches and grease.
- Inspect shaft to be sure it is free of nicks and scratches.
- Reassemble pump body half to motor flange. **BE SURE** it is right side up.
- Apply liquid soap sparingly (one drop is sufficient) to inside diameter of rotating seal member.
- Slide rotating seal member (carbon face first) onto shaft until rubber drive ring hits shaft shoulder.

NOTICE: Be sure not to nick or scratch carbon face of seal when passing it over threaded shaft end or shaft shoulder. The carbon surface must remain clean or short seal life will result.

- Hold motor shaft with 7/16" open end wrench on shaft flats (Figure 14, Page 8) and screw impeller onto shaft. **Be sure you do not touch capacitor terminals with body or any metal object.** Tightening impeller will automatically locate seal in correct position.
- Remount diffuser on pump body half with five screws.

PUMP REASSEMBLY

- Clean O-Ring and O-Ring groove.
- Put O-Ring in groove on face of flange; put pump halves together (see Figure 18).

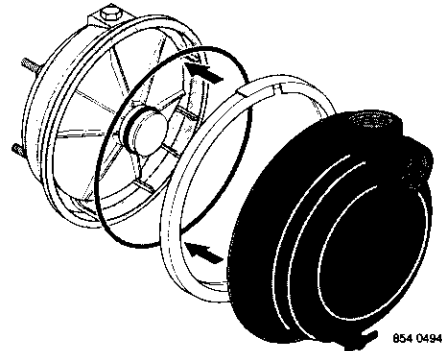

Figure 18 – Assemble Pump

- BE SURE** inside of clamp is clean. Place clamp on pump halves; snug up. Alternately tighten screw and tap clamp with mallet to seat O-Ring (see Figure 19).

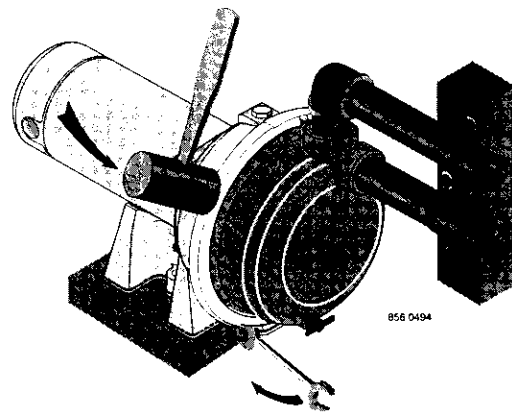

Figure 19 – Tap Clamp While Tightening

- Replace base mounting bolts.
- Replace motor wiring; close draincock.
- Prime pump according to instructions. See "Operation."
- Check for leaks.

TROUBLESHOOTING CHART

SYMPTOM	POSSIBLE CAUSE(S)	CORRECTIVE ACTION
Motor will not run	<ol style="list-style-type: none"> 1. Disconnect switch is off 2. Fuse is blown 3. Starting switch is defective 4. Wires at motor are loose, disconnected, or wired incorrectly 	<ol style="list-style-type: none"> 1. Be sure switch is on 2. Replace fuse 3. Replace starting switch 4. Refer to instructions on wiring. Check and tighten all wiring. <p>⚠ WARNING Capacitor voltage may be hazardous. To discharge capacitor, hold insulated handle screwdriver BY THE HANDLE and short capacitor terminals together. Do not touch metal screwdriver blade or capacitor terminals. If in doubt, consult a qualified electrician.</p>
Motor runs hot and overload kicks off	<ol style="list-style-type: none"> 1. Motor is wired incorrectly 2. Voltage is too low 	<ol style="list-style-type: none"> 1. Refer to instructions on wiring 2. Check with power company. Install heavier wiring if wire size is too small (See Electrical, Pages 5 and 6)
Motor runs but no water is delivered *(Note: Check prime before looking for other causes. Unscrew priming plug and see if there is water in priming hole.)	<ol style="list-style-type: none"> *1. Pump in new installation did not pick up prime through: <ol style="list-style-type: none"> a. Improper priming b. Air leaks c. Leaking foot valve *2. Pump has lost prime through: <ol style="list-style-type: none"> a. Air leaks b. Water level below suction of pump 3. Impeller is plugged 4. Check valve or foot valve is stuck in closed position 5. Pipes are frozen 6. Foot valve and/or strainer are buried in sand or mud 	<ol style="list-style-type: none"> 1. In new installation: <ol style="list-style-type: none"> a. Re-prime according to instructions b. Check all connections on suction line c. Replace foot valve 2. In installation already in use: <ol style="list-style-type: none"> a. Check all connections on suction line and shaft seal b. Lower suction line into water and re-prime. If receding water level in well exceeds suction lift, a deep well pump is needed 3. Clean impeller; see Maintenance 4. Replace check valve or foot valve 5. Thaw pipes. Bury pipes below frost line. Heat pit or pump house. 6. Raise foot valve and/or strainer above well bottom
Pump does not deliver water to full capacity (Also check point 3 immediately above)	<ol style="list-style-type: none"> 1. Water level in well is lower than estimated 2. Steel piping (if used) is corroded or limed, causing excess friction 3. Offset piping is too small in size 	<ol style="list-style-type: none"> 1. A deep well jet pump may be needed (over 20 ft. to water) 2. Replace with plastic pipe where possible, otherwise with new steel pipe 3. Use larger offset piping
Pump leaks around clamp	<ol style="list-style-type: none"> 1. Clamp loose 	<ol style="list-style-type: none"> 1. STOP PUMP, tighten clamp nut 1-2 turns. Alternately tighten nut and and tap clamp with mallet to seat O-Ring. Do not overtighten

REPAIR PARTS

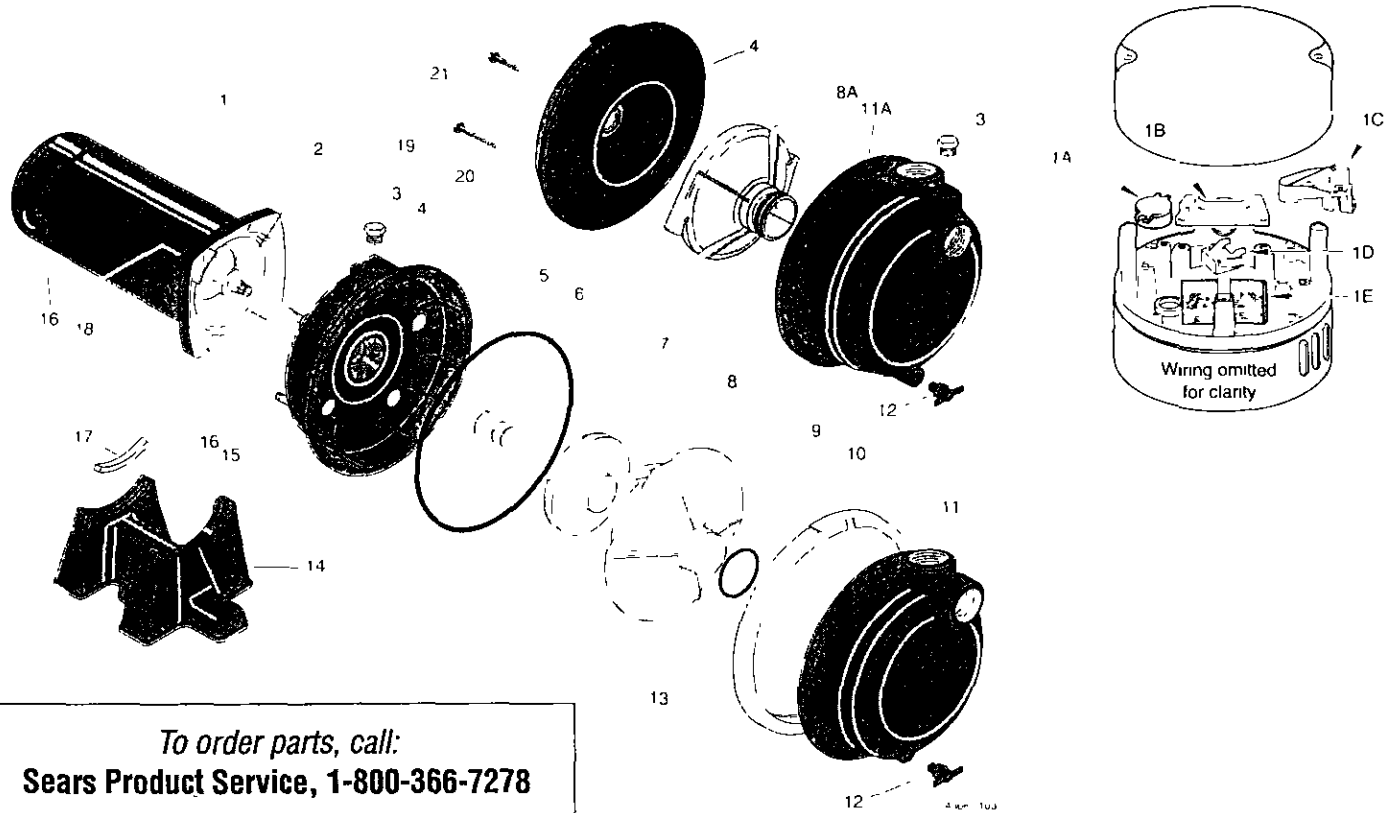

**To order parts, call:
Sears Product Service, 1-800-366-7278**

Key No	Part Description	390.262454 115/230V 60 Cy/1 Ph 1 HP	390.262553 115/230V 60 Cy/1 Ph 1-1/2 HP	390.262653 230V 60 Cy/1 Ph 2 HP
1	Motor	J218-1029	J218-956C	A100GSL
1A	Overload Protector	-	U18-1342	U18-1406
1B	Terminal Board	-	U18-1180	U18-1180
1C	Contactor	-	U18-1098	U18-1098
1D	Governor	-	U18-128	U18-128
1E	Capacitor	-	U18-525	U18-525
2	Slinger	17351-0009	17351-0009	17351-0009
3	Priming Plug 1/2" NPT	WC78-39T	WC78-39T	WC78-39T
4	Tank Body Back Half Complete	L176-47P1	L176-47P1	C3-189P1
5	O-Ring	U9-399	U9-399	U9-228A
6	Shaft Seal for 5/8" Shaft	U109-6A	U109-6A	U109-6A
7	Impeller	C105-92PVB	C105-92PBBB	C105-214PFA
	• Impeller Screw	-	-	C30-51SS
8	Diffuser	C1-258PCA	C1-258PCA	-
8A	Diffuser	-	-	C1-274P
9	Screw - #8 - 32 RH (1 and 1-1/2 HP - 4 Req'd 2 HP - 2 Req'd)	U30-869SS	U30-869SS	U30-542SS
	• Lockwasher	-	-	U43-21SS
10	"V" Clamp	C19-54SS	C19-54SS	C19-37A
11	Tank Body Front Half (Incl No 12)	C176-53PA	C176-53PA	-
11A	Tank Body Front Half Complete (Incl Nos 3 and 12)	-	-	C176-62PA
12	Draincock - 1/4 NPT	U212-68T	U212-68T	U212-68T
13	O-Ring	U9-226	U9-226	U9-393
14	Base	C4-42P	C4-42P	C4-42P
15	Flat Washer 5/16 (2 Req'd)	U43-61ZP	U43-61ZP	-
16	Nut - 5/16 - 18 (4 Req'd)	U36-37ZP	U36-37ZP	-
17	Rubber Pad	C35-11	C35-11	C35-11
18	Lock Washer - 5/16 (2 Req'd)	U43 11ZP	U43-11ZP	-
19	Capscrew, 3/8 - 16 x 1-3/4" (2 Req'd)	-	-	U30-77SS
20	Flat Washer 5/16 (2 Req'd)	-	-	U43-42SS
21	Capscrew, 3/8 - 16 x 1" (2 Req'd)	-	-	U30-74SS

• Not illustrated

SEARS

OWNER'S MANUAL

Model No.
390.262454
390.262553
390.262653

The model number of your Sprinkler Pump will be found on a plate attached to the side of the pump body.

When requesting service or ordering parts, always give the following information:

- Product Type
- Model Number
- Part Number
- Part Description

CRAFTSMAN® HYDROGLASS® HIGH PRESSURE SPRINKLER PUMP

For the repair or replacement parts you need
Call 7 am - 7 pm, 7 days a week
1-800-366-PART
(1-800-366-7278)



For in-home major brand repair service
Call 24 hours a day, 7 days a week
1-800-4-REPAIR
(1-800-473-7247)



**For the location of a
Sears Repair Service Center in your area**
Call 24 hours a day, 7 days a week
1-800-488-1222



**For information on purchasing a Sears
Maintenance Agreement or to inquire
about an existing Agreement**
call 9 am - 5 pm, Monday-Saturday
1-800-827-6655



SEARS
REPAIR SERVICES
America's Repair Specialists

Sears, Roebuck and Co., Hoffman Estates, IL 60179 U.S.A.

Free Manuals Download Website

<http://myh66.com>

<http://usermanuals.us>

<http://www.somanuals.com>

<http://www.4manuals.cc>

<http://www.manual-lib.com>

<http://www.404manual.com>

<http://www.luxmanual.com>

<http://aubethermostatmanual.com>

Golf course search by state

<http://golfingnear.com>

Email search by domain

<http://emailbydomain.com>

Auto manuals search

<http://auto.somanuals.com>

TV manuals search

<http://tv.somanuals.com>