

**CRATE** *Sprint*  
*series*  
**CR-280 AMPLIFIER**

PART NO. 47-580-01

# CRATE *Sprint* series



We would like to take this opportunity to thank you for selecting a Crate product, and to advise you of our commitment to the design and manufacture of only the finest musical instrument amplification equipment; built for you, the musicians.

You have purchased one of the most innovative sound amplification devices available today. Your Crate amplifier gives you more performance features than ever before, features that you the musician have asked for.

Your Crate amplifier is an American product manufactured at the Crate factory located in St. Louis, Mo. Only the finest available components and materials are used in the manufacture of each Crate amplifier.

All Crate amplifiers are subjected to seven or more inspection and testing steps to assure you of a high quality product. The final test for each amp is conducted by a trained musician with the instrument the amplifier was designed for. Any Crate that does not meet the standards of his discriminating ear will not be passed.

Since all Crate products are designed, developed, and manufactured through the co-operative efforts of engineers and professional musicians, the end result is a product that responds to the musician's audio requirements, and a product that will serve your needs for years to come.

## Model #CR-280 Guitar Amplifier Features:

CR-280 Black Tolex Unit

Front Panel (Left to Right)		Rear + Under Panel (Right to Left)
Input Jack 0DB	Manual SCG Select Sw.	Line Out/Effects Send (Under Panel)
Input Jack -6DB	Master Volume Control	Line In/Effects Return (Under Panel)
Gain Control	Final EQ—Warmth Control	Ext. Spk. Jack (Under Panel)
Lo Control	Final EQ—Presence Control	Int. Spk. Jack (Under Panel)
Mid Control	Reverb Depth Control	A-C Conv. Outlet
Hi Control	Reverb LED "On" Indicator	External Fuse Holder
Bright Sw. +8DB	A-C LED "On" Indicator	9' Heavy Duty A-C Cord (Under Panel)
SCG Drive Control	A-C Power Switch	
SCG Mix Control		
SCG LED "On" Indicator		
Remote Ft. Sw. Jack		

# OPERATION and MAINTENANCE

## INSTRUMENT INPUT:

### 1) 0DB INPUT JACK (0DB)

This input is to be used with most guitars. It will provide the player with optimum performance of his instrument.

### 2) -6DB INPUT JACK (-6DB):

If unwanted distortion is present when the guitar is plugged into the 0DB input, this may be remedied by using the -6DB input. Normal or clean channel gain as well as the SCG channel gain will be reduced by 6DB.

## NOTE:

### NORMAL OR CLEAN CHANNEL OPERATION:

Normal or clean channel operation is obtained with the SCG booster channel switch (12) set to the right or "off" position. The SCG LED "on" indicator (10) will be off. For best results, it is suggested that the normal or "clean" channel settings should be made prior to SCG booster channel adjustments.

### 3) GAIN CONTROL (Gain):

When playing through the normal or "clean" channel, the amount of initial gain applied to the instrument input is determined with this knob, with final gain being determined by the master volume (13). This input gain control will retain operation when the SCG booster channel is in use.

## PRIMARY EQUALIZATION:

(All EQ controls will operate with either channel selected.)

### 4) LO EQ CONTROL (Lo):

The desired amount of "bass" or "bottom" may be increased or decreased with this knob.

### 5) MID EQ CONTROL (Mid):

The tonal qualities of the midrange are very important to a good guitar sound. This knob can "thin out" the sound when turned down, or "fatten up" the tone when larger amounts are used.

### 6) HIGH EQ CONTROL (High):

This knob affects the upper harmonic range of the guitar. In the normal or "clean" channel mode it sharpens or adds "crispness" to the sound, while in the SCG booster channel mode it brings out the "bite" or "edge" of the guitar. For additional effect, use this control in conjunction with the bright switch (7).

### 7) BRIGHT SWITCH (Bright +8DB):

This switch affects the brilliance of the guitar sound by adding additional "crispness" or "bite".

## SCG BOOSTER CHANNEL:

NOTE: The SCG booster channel controls will operate only when the SCG channel select switch (12) is in the left or "on" position, and the LED "on" indicator (10) is lit.

### 8) DRIVE CONTROL (Drive):

This knob operates similar to an overdrive or distortion control, and determines the amount of drive gain. By increasing the amount of drive gain, the player will increase the amount of distortion and sustain of the guitar.



### 9) MIX CONTROL (Mix):

Use of this knob when SCG booster channel operation is selected, will allow the player to adjust the "mix" or "blend" of the SCG booster channel sound in comparison to the normal or "clean" channel sound.

### 10) SCG BOOSTER CHANNEL LED:

This LED will illuminate when the SCG booster channel is active.

### 11) FOOTSWITCH JACK (Ft. Sw.):

This jack is provided for use with the optional remote foot switch unit. The optional foot switch allows remote operation of the SCG booster channel as well as the reverb circuit. When the foot switch is used to control the SCG booster channel, the manual SCG channel select switch (12) must be in the left or SCG channel select position for proper operation.

### 12) THE SCG BOOSTER CHANNEL SELECTOR SWITCH (SCG Channel Select):

This switch offers manual selection of SCG booster or normal channel operation. SCG booster channel operation is obtained with this switch in the left position, while normal channel operation is obtained with the switch in the right position. When using a remote foot switch, this switch must be in the left or SCG booster "on" position.

## MASTER:

### 13) MASTER VOLUME (Volume):

The overall volume of the CR-280 is controlled at this point. It determines the volume of both normal and SCG booster channels.

## FINAL EQUALIZATION:

### 14) WARMTH CONTROL (Warmth):

This knob acts similar to an additional bass control, and allows the player to adjust the "warmth" or "bottom" of the guitar sound in the final stages of the preamp.

### 15) PRESENCE CONTROL (Presence):

This knob acts similar to an additional treble control, and allows the player to adjust the "presence" or "crispness" of the guitar sound in the final stages of the preamp.

## REVERB:

### 16) DEPTH CONTROL (Depth):

The apparent acoustical qualities of a room can be altered through the use of this knob. A "flat" or "dry" effect is obtained with the control off, and with increased settings a "concert hall" effect is created.

### 17) REVERB LED INDICATOR:

When this LED is illuminated, reverb is available. When using the optional foot switch, the player will be able to turn the reverb circuit

off, and this LED will turn off. If the footswitch is not plugged in, this LED will remain lit at all times.

## POWER:

### 18) ON/OFF LED INDICATOR:

The amplifier is on when this LED is lit.

### 19) ON/OFF SWITCH (On):

This is a two position switch. The down position will turn the unit on, while the up position is off.

## REAR PANEL:

### 20) FUSE HOLDER:

This is a safety valve for the amplifier. Should problems occur, check the fuse. If problems persist after fuse replacement, consult an authorized Crate service center.

### 21) AC CONV. OUTLET:

This outlet is for additional power needs, such as effects boxes or additional amplifiers. Be sure not to overload this outlet.

### 22) POWER CORD (Under Panel):

Be sure the amplifier is properly plugged into a safely wired outlet before use.

## ADDITIONAL INPUTS AND OUTPUTS (Located Under Panel):

### 23) INTERNAL SPEAKER JACK (Int.):

This is the output for the amplifiers self-contained speakers.

### 24) EXTERNAL SPEAKER JACK (Ext.):

For additional speaker usage, connect to this speaker jack. Use only speakers of 4 ohms or higher impedance.

### 25) LINE IN JACK (Line In):

This jack provides an input into the CR-280 power amplifier. It can be used as an effects loop return, or in stacking the amplifier with another preamp. The internal preamp of the CR-280 is disconnected when using this jack.

### 26) LINE OUT JACK (Line Out):

This output enables the player to link the CR-280 to other amplifiers for increased volume and coverage. Simply run a cord from the line out jack to the input or line in of another amplifier. In addition, this output can be used as an effects loop send.

## EFFECTS LOOP OPERATION:

When the Line In and Line Out Jacks are properly connected to an external effects unit, an effects loop is created, and the amplifiers pre-amp signal will be routed to the effects unit and returned to the power amplifier input. Simply connect a cord from the Line Out Jack of the amplifier to the input or instrument jack of the effect, and an additional cord from the effect output or "To Amp" jack to the Line In Jack of the amplifier.



20 21 22 23 24

25 26

REAR PANEL VIEW:

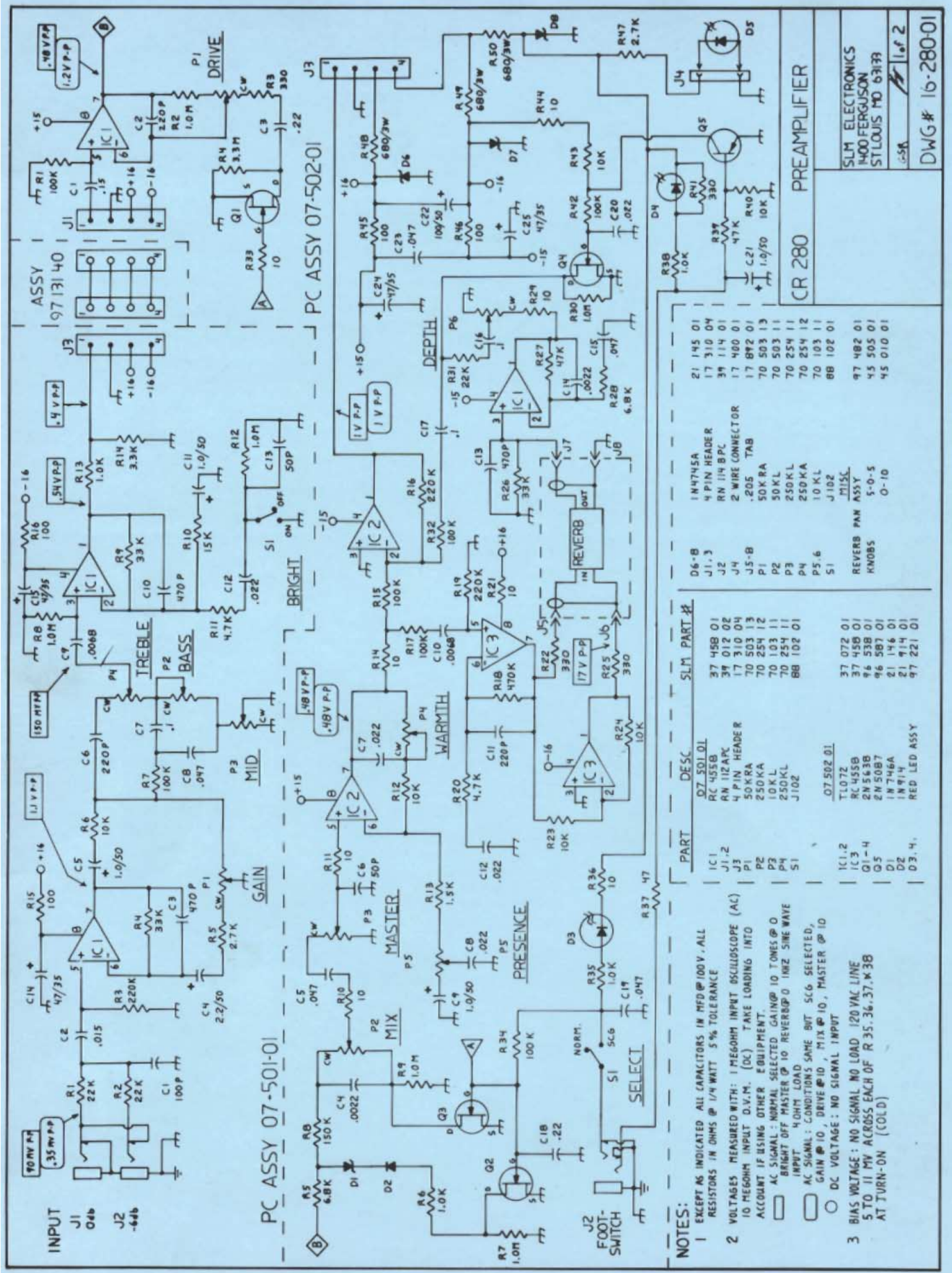

**CR 280 PREAMPLIFIER**

SLM ELECTRONICS  
1400 FERGUSON  
ST LOUIS MO 63133

1 of 2  
DWG # 16-280-01

PART	DESC	SLM PART #
IC1	07 501 01	
IC2	07 502 01	
IC3	TLO72	37 458 01
Q1-Q4	8C455B	39 012 02
Q5	2N563B	17 310 04
D1	2N50B7	50KRA
D2	1N746A	70 503 13
D3	1N914	70 254 12
D4	1N914	70 103 11
D5	RED LED ASSY	70 254 11
D6	1N475A	88 102 01
J1	4 PIN HEADER	21 145 01
J2	4 PIN HEADER	17 310 04
J3	2 WIRE CONNECTOR	39 114 01
J4	.205 TAB	17 400 01
J5	50K RA	70 503 13
P1	50KL	70 503 11
P2	250KL	70 254 11
P3	250KA	70 254 12
P4	10 KL	70 103 11
P5	J102	88 102 01
S1	MISC	
S2	REVERB PAN ASSY	97 482 01
S3	KN085	45 505 01
S4	0-10	45 010 01

- NOTES:**
- EXCEPT AS INDICATED ALL CAPACITORS IN MFD @ 100V. ALL RESISTORS IN OHMS @ 1/4 WATT 5% TOLERANCE
  - VOLTAGES MEASURED WITH: 1 MEGOHM INPUT OSCILLOSCOPE (AC) 10 MEGOHM INPUT D.V.M. (DC) TAKE LOADING INTO ACCOUNT IF USING OTHER EQUIPMENT.  
AC SIGNAL: NORMAL SELECTED GAIN @ 10 TONES @ 0 BRIGHT OFF MASTER @ 10 REVERB @ 0 1M2 SINE WAVE INPUT 4 OHM LOAD  
AC SIGNAL: CONDITIONS SAME BUT SC6 SELECTED, GAIN @ 10, DRIVE @ 10, MIX @ 10, MASTER @ 10  
DC VOLTAGE: NO SIGNAL INPUT
  - BIAS VOLTAGE: NO SIGNAL NO LOAD 120 VAC LINE 5 TO 11 MV ACROSS EACH OF R35, R36, R37, R38 AT TURN-ON (COLD)

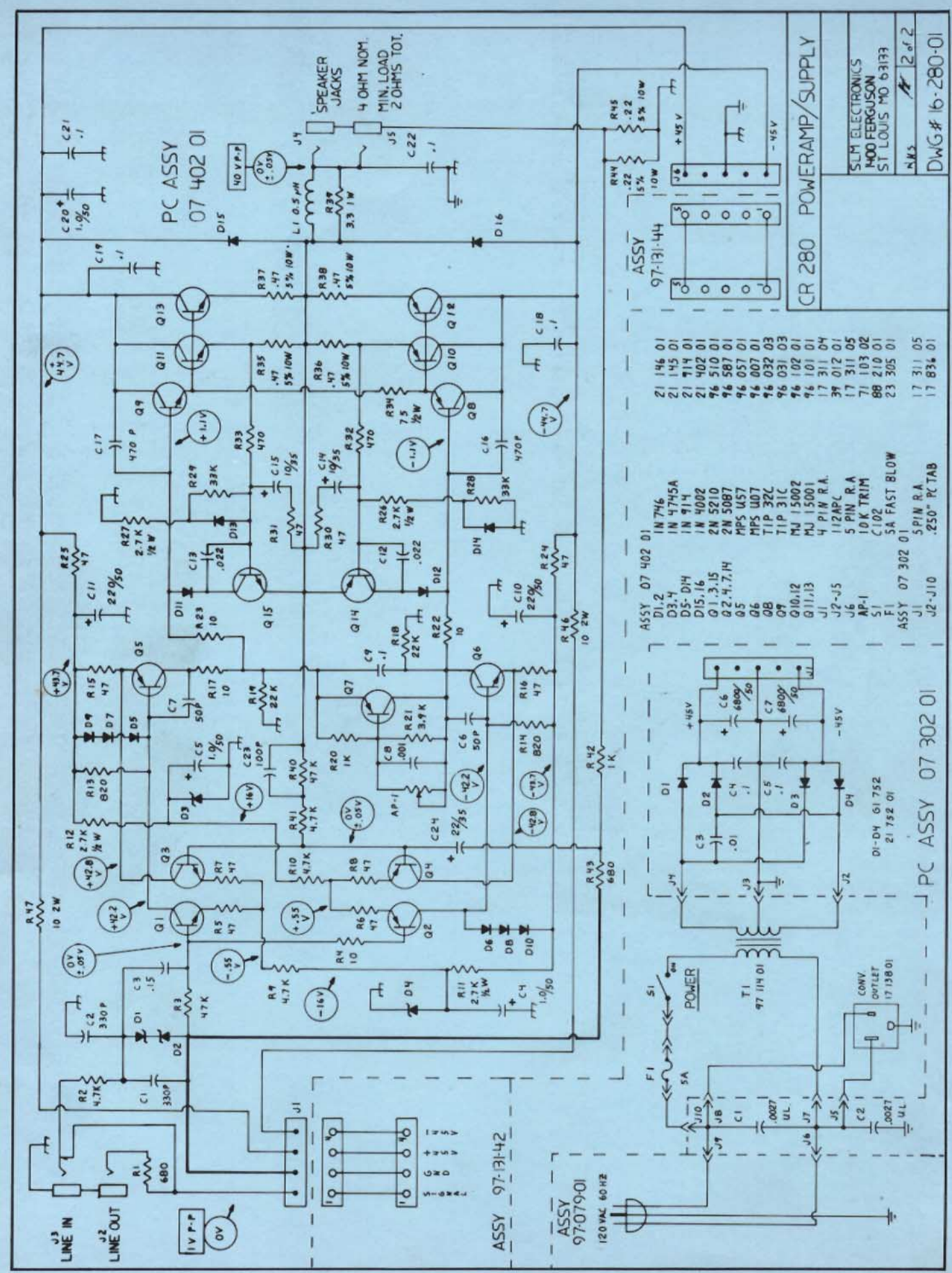

PC ASSY  
07 402 01

CR 280 POWERAMP/SUPPLY

- ASSY 07 402 01
- D1,2 IN 746
  - D3,4 IN 4745A
  - D5-D14 IN 914
  - D15,16 IN 4002
  - Q1,3,15 2N 5210
  - Q2,4,7,14 2N 5087
  - Q5 MPS U57
  - Q6 MPS U07
  - Q8 TIP 32C
  - Q9 TIP 31C
  - Q10,12 MJ 15002
  - Q11,13 MJ 15001
  - J1 4 PIN R.A.
  - J2-J5 112APC
  - J6 5 PIN R.A.
  - AP-1 10K TRIM
  - S1 C102
  - F1 SA FAST BLOW
  - ASSY 07 302 01
  - J1 5 PIN R.A.
  - J2-J10 .250" PCTAB
- ASSY 97-131-44
- Z1 146 01
  - Z1 145 01
  - Z1 114 01
  - Z1 402 01
  - Z6 510 01
  - Z6 587 01
  - Z6 057 01
  - Z6 007 01
  - Z6 032 03
  - Z6 031 03
  - Z6 102 01
  - Z6 101 01
  - Z7 311 04
  - Z8 012 01
  - Z7 311 05
  - Z7 103 02
  - Z8 210 01
  - Z3 305 01
  - Z7 311 05
  - Z7 836 01

SLM ELECTRONICS  
1400 FERGUSON  
ST LOUIS MO 63133  
NKS  
12 of 2  
DWG# 16-280-01

PC ASSY 07 302 01

## LIMITED WARRANTY

SLM Electronics, a division of St. Louis Music Supply Company, warrants this electronic equipment for one (1) year from date of purchase to the original purchaser and is not transferable. This warranty includes defects in workmanship and materials within this one (1) year period except for tubes, meters and speakers covered separately. Tubes and meters will carry a 90 day warranty.

Excluded from this warranty are defects caused by wear and tear, misuse, neglect, alterations or modifications, or any act of nature. Such determinations will be made by SLM Electronics.

All parts costs will be borne by SLM Electronics within the warranty period. Labor costs will be covered within this warranty period according to rate schedules established by SLM Electronics. Warranty service will be done either at SLM Electronics or an authorized field service center. Transportation charges involved in warranty service are the sole responsibility of the purchaser.

Crate speakers are guaranteed for ninety (90) days against manufacturing defects. Realizing that any speaker can be overloaded or misused causing failure, Crate will replace it with a speaker of the same type at a price equal to one-half of the then current suggested list price of the new speaker for life from date of registration, regardless of reason.

This warranty only applies if this piece of Crate equipment was purchased from an authorized Crate Dealer. If this Crate piece of equipment is to be returned to SLM Electronics, it must be accompanied with an authorized Crate Dealer's instructions as to needed repairs and a SLM Electronics return authorization.

There are no other warranties expressed or implied other than those stated in this warranty. This warranty registration card must be filled out and returned to us within ten (10) days after purchase. We reserve the right to repair or replace this piece of Crate equipment at our option.

SLM ELECTRONICS division of ST. LOUIS MUSIC  
1400 Ferguson Ave. • St. Louis, Mo. 63133

## DETAILED SPECIFICATIONS:

<b>INPUT IMPEDANCE</b>	220K Ohms 0DB Jack (Hi Sensitivity) 44K Ohms -6DB Jack (Lo Sensitivity)	<b>FUSE, RATING AND TYPE</b>	External Fuse Holder with 5 Amp Fast Acting 250V. Fuse—Type 3AG-5 or Equivalent.
<b>MAXIMUM SIGNAL LEVEL ACCEPTED</b>	0DB Input 17 V.P.P./6V. RMS. -6DB Input 30 V.P.P./10V. RMS.	<b>A-C CONV. OUTLET RATING</b>	300 Watts Maximum.
<b>EQUALIZATION</b>	Special Design Lo, Mid, High Passive Controls, +8DB Bright Boost, Special Design Warmth and Presence Active Controls.	<b>SPEAKER SIZE AND RATING</b>	2-12" Dia. Special Design 8Ohm Speakers. 2" Dia. Alum. Voice Coil, 38 Oz. Magnet. Rated 80 Watts RMS/120 Watts EIA Ea.
<b>TOTAL GAIN</b>	Normal Channel/Gains "Full"—Tones "0" 54DB Gain/120 MV P.P. Sensitivity @ 1400 Hz. SCG Booster Channel/Gains "Full"—Tones "0" 100 DB Gain/.6 MV P.P. Sensitivity @ 1400 Hz.	<b>EXTERNAL SPEAKER JACK</b>	4 Ohm Minimum Impedance
<b>SIGNAL TO NOISE RATIO</b>	All Tones "Full"—Bright "On"—Reverb Off— Gains @ Mid Rotation. Normal Channel 70DB, SCG Booster Channel 60DB.	<b>CABINET SIZE AND WEIGHT</b>	21" H. x 26½" W. x 11"D. 30 Lbs. Total
<b>PREAMP OUTPUT/</b>	Normal 1.7 V.P.P. @ 10K Load/ .8V.P.P. @ 600 Ohms.	<b>SHIPPING WEIGHT</b>	45 Lbs. Total
<b>LINE OUT</b>	Maximum 25 V.P.P. @ 10K Load/ 9 V.P.P. @ 600 Ohms.	<b>CAUTION:</b> To reduce the risk of electric shock, do not remove chassis. No user serviceable parts inside. Refer servicing to qualified service personnel. To reduce the risk of fire or electric shock, do not expose this appliance to rain or moisture.  <b>CAUTION:</b> To reduce the risk of fire, replace fuse with only same type 5 amp 250 V. normal blow 3AG fuse. Disconnect line cord before replacing fuse.	
<b>POWER AMP INPUT/LINE IN</b>	Sensitivity = 1.7 V.P.P. for Full RMS Output @ 4 Ohms = .6 V RMS or -4DBV.		
<b>OUTPUT POWER RATING</b>	All Ratings @ 5% THD 120 VAC Line 16 Ohm Load—54 Watts 8 Ohm Load—93 Watts 4 Ohm Load—150 Watts 2 Ohm Load—208 Watts Loads Below 2 Ohms Not Recommended		
<b>INPUT POWER REQUIREMENTS</b>	@ 150 Watts into 4 Ohms @ 5% THD, 250 Watts Power Input Required. Nominal Idle Power Required = 20 W.		

## Free Manuals Download Website

<http://myh66.com>

<http://usermanuals.us>

<http://www.somanuals.com>

<http://www.4manuals.cc>

<http://www.manual-lib.com>

<http://www.404manual.com>

<http://www.luxmanual.com>

<http://aubethermostatmanual.com>

Golf course search by state

<http://golfingnear.com>

Email search by domain

<http://emailbydomain.com>

Auto manuals search

<http://auto.somanuals.com>

TV manuals search

<http://tv.somanuals.com>