

**CRATE** FXT65

# FXT65

## Guitar Amplifier with Digital Signal Processing and Channel Tracking



## User's Guide

# CRATE **FXT65** Guitar Amp with DSP & Channel Tracking

## Congratulations!

You are now the proud owner of the Crate FXT65 amplifier. This rugged amplifier combines outstanding features with serious clean and distorted sounds. An easy to operate DSP section lets you dial in a variety of digital effects including reverbs, delays, octave and wah-wahs. Crate's unique **Channel Tracking** feature means that as you switch between channels and gains, the DSP automatically "tracks" the changes - your DSP settings for each channel are recalled! The supplied three-button footswitch allows you to select channels, change the Overdrive Gain, and turn the DSP on and off by "remote control." The top-mounted electronic tuner lets you get tuned and stay in tune any time the amp is on.





Like all Crate products, your FXT amplifier is designed by musicians, and built using only the best components. Extensive testing confirms that this amplifier is the absolute best it can be.

In order to get the most out of your new amplifier, we strongly urge you to read the information contained in this manual before you begin playing.

And **thank you** for choosing **CRATE**.

### TABLE OF CONTENTS:

The Digital Signal Processor .....	3
Channel Tracking .....	3
The Front Panel .....	4,5
The Electronic Tuner .....	5
The Rear Panel (not shown) .....	5
Suggested Settings .....	6
System Block Diagram .....	7
Technical Specifications .....	back cover

 <b>CAUTION</b> RISK OF ELECTRIC SHOCK DO NOT OPEN	 <b>PRECAUCION</b> RIESGO DE CORRIENTAZO NO ABRA	 <b>ATTENTION</b> RISQUE D'ELECTROCUTION NE PAS OUVRIR
WARNING: TO REDUCE THE RISK OF FIRE OR ELECTRIC SHOCK, DO NOT EXPOSE THIS APPARATUS TO RAIN OR MOISTURE. TO REDUCE THE RISK OF ELECTRIC SHOCK, DO NOT REMOVE COVER. NO USER-SERVICEABLE PARTS INSIDE. REFER SERVICING TO QUALIFIED SERVICE PERSONNEL.	PRECAUCION: PARA REDUCIR EL RIESGO DE INCENDIOS O DESCARGAS ELECTRICAS, NO PERMITA QUE ESTE APARATO QUEDE EXPUESTO A LA LLUVIA O LA HUMEDAD. PARA DISMINUIR EL RIESGO DE CORRIENTAZO, NO ABRA LA CUBIERTA. NO HAY PIEZAS ADENTRO QUE EL USUARIO PUEDE REPARAR DEJE TODO MANTENIMIENTO A LOS TECNICOS CALIFICADOS.	ATTENTION: PROTEGEZ CET APPAREIL DE LA PLUIE ET DE L'HUMIDITE AFIN D'EVITER TOUT RISQUE D'INCENDIE OU D'ELECTROCUTION. POUR REDUIRE D'ELECTROCUTION NE PAS ENLEVER LE COUVERCLE. AUCUNE PIECE INTERNE N'EST REPARABLE PAR L'UTILISATEUR. POUR TOUTE REPARATION, S'ADRESSER A UN TECHNICIEN QUALIFIE.
<h3>IMPORTANT SAFETY INSTRUCTIONS</h3>		
<ul style="list-style-type: none"> <li>• READ, FOLLOW, HEED, AND KEEP ALL INSTRUCTIONS AND WARNINGS.</li> <li>• DO NOT OPERATE NEAR ANY HEAT SOURCE AND DO NOT BLOCK ANY VENTILATION OPENINGS ON THIS APPARATUS. FOR PROPER OPERATION, THIS UNIT REQUIRES 3" (75mm) OF WELL VENTILATED SPACE AROUND HEATSINKS AND OTHER AIR FLOW PROVISIONS IN THE CABINET.</li> <li>• DO NOT USE THIS APPARATUS NEAR SPLASHING, FALLING, SPRAYING, OR STANDING LIQUIDS.</li> <li>• CLEAN ONLY WITH LINT-FREE DAMP CLOTH AND DO NOT USE CLEANING AGENTS.</li> <li>• ONLY CONNECT POWER CORD TO A POLARIZED, SAFETY GROUNDED OUTLET WIRED TO CURRENT ELECTRICAL CODES AND COMPATIBLE WITH VOLTAGE, POWER, AND FREQUENCY REQUIREMENTS STATED ON THE REAR PANEL OF THE APPARATUS.</li> <li>• PROTECT THE POWER CORD FROM DAMAGE DUE TO BEING WALKED ON, PINCHED, OR STRAINED.</li> <li>• UNPLUG THE APPARATUS DURING LIGHTNING STORMS OR WHEN UNUSED FOR LONG PERIODS OF TIME.</li> <li>• ONLY USE ATTACHMENTS, ACCESSORIES, STANDS, OR BRACKETS SPECIFIED BY THE MANUFACTURER FOR SAFE OPERATION AND TO AVOID INJURY.</li> <li>• WARNING: TO REDUCE THE RISK OF ELECTRIC SHOCK OR FIRE, DO NOT EXPOSE THIS UNIT TO RAIN OR MOISTURE.</li> <li>• SERVICE MUST BE PERFORMED BY QUALIFIED PERSONNEL.</li> <li>• OUR AMPLIFIERS ARE CAPABLE OF PRODUCING HIGH SOUND PRESSURE LEVELS. CONTINUED EXPOSURE TO HIGH SOUND PRESSURE LEVELS CAN CAUSE PERMANENT HEARING IMPAIRMENT OR LOSS. USER CAUTION IS ADVISED AND EAR PROTECTION IS RECOMMENDED IF UNIT IS OPERATED AT HIGH VOLUME.</li> </ul>		
EXPLANATION OF GRAPHICAL SYMBOLS: EXPLICACION DE SIMBOLOS GRAFICOS: EXPLICATION DES SYMBOLES GRAPHIQUES:	 = "DANGEROUS VOLTAGE" "VOLTAJE PELIGROSO" "DANGER HAUTE TENSION"	 = "IT IS NECESSARY FOR THE USER TO REFER TO THE INSTRUCTION MANUAL" "ES NECESARIO QUE EL USUARIO SE REFIERA AL MANUAL DE INSTRUCCIONES." "REFERREZ-VOUS AU MANUAL D'UTILISATION"

**The Digital Signal Processor:**

The FXT65's Digital Signal Processor provides 16 exciting digital effects. Use the DSP Selector control to choose the desired effect, then use the DSP Level control to mix in the desired amount of effect.

The effects are described below:

FLNG 1	slow deep flange + reverb
FLNG 2	flange + reverb + delay
CHO 1	slow tremolo chorus + reverb
CHO 2	chorus + reverb + delay
RTRY	simulated rotary speaker effect
OCTV DOWN	adds a signal one octave lower than input
T-WAH	touch sensitive wah-wah effect
I-WAH	inverse wah-wah effect
DOUBLER	simulated second track, slightly out of sync
REV (1)	small room reverb
REV (2)	medium room reverb
REV (3)	large room reverb
REV (4)	concert hall reverb
DLY (1)	short slapback + small room reverb
DLY (2)	medium delay + plate reverb
DLY (3)	long delay + large room reverb



**Channel Tracking:**

The FXT65 gives you the power of **Channel Tracking!** Once you select a DSP setting for each channel, **Channel Tracking** recalls those DSP setting automatically – without changing the DSP controls!

For example:

- Select the Clean channel. Set the DSP Selector to “FLNG 1” (*slow flange + reverb*)
- Select the Overdrive channel, Gain 1. Set the DSP Selector to “CHO 1” (*slow chorus + reverb*) (the setting for the Clean channel is now saved to memory)
- Select the Overdrive channel, Gain 2. Set the DSP Selector to “T-WAH” (*touch wah-wah*) (the setting for the Overdrive channel, Gain 1 is now saved to memory)
- Reselect the Clean channel (the setting for the Overdrive channel, Gain 2 is now saved to memory)

Now when you go back to the Clean channel, even though the DSP Selector was last set to “T-WAH,” **Channel Tracking** automatically recalls the last setting for the Clean channel – in this example, “FLNG 1.” Change to the Overdrive channel, Gain 1, and “CHO 1” is recalled. Change to the Overdrive channel, Gain 2, and “T-WAH” is recalled. That’s the power of **Channel Tracking!**

(Note: Even when the power is turned off, **Channel Tracking** still retains the settings – until **you** change them!)

## The Front Panel:

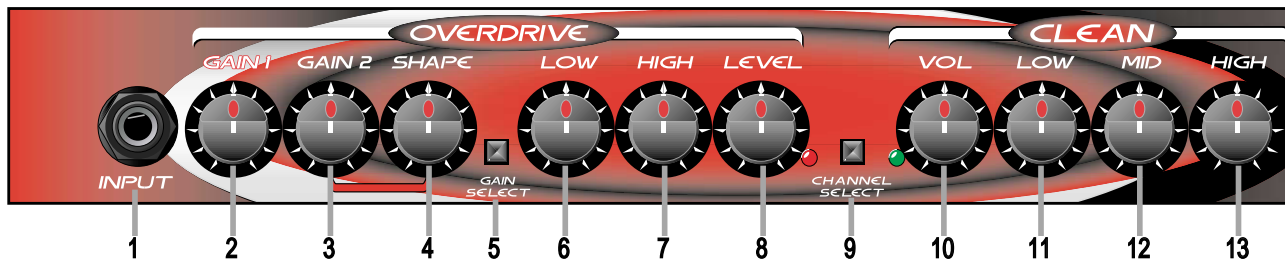

**1: INPUT:** Use this jack to connect your guitar to the amplifier by means of a shielded instrument cable.

**OVERDRIVE CHANNEL:** A high gain channel giving you sounds from a slight edge to serious overdrive.

**2: GAIN 1:** Use this control to adjust the amount of light distortion for the Overdrive channel. Gain 1 produces less intense distortion than Gain 2 (#3) and is active when the Gain Select switch (#5) is in the out position.

**3: GAIN 2:** Use this control to adjust the amount of heavy distortion for the Overdrive channel. Gain 2 produces more intense distortion than Gain 1 (#2) and is active when the Gain switch (#5) is depressed.

**4: SHAPE:** Use this control to “dial in” the tone for the Overdrive channel when Gain 2 is selected. Rotating the control counterclockwise enhances the mid frequencies, while rotating the control clockwise enhances the low and high frequencies. This control is only active when Gain 2 is selected.

**5: GAIN SELECT:** Use this switch to select which Gain control is active for the Overdrive channel. With the switch in the out position, Gain 1 is selected. When the switch is depressed, Gain 2 is selected. When a footswitch is connected to the Channel / Gain Select Footswitch jack (#21), this switch is rendered inactive and the Gain Select function is controlled by the footswitch (see #21).

**6: LOW:** Use this control to adjust the low frequency level of the Overdrive channel.

**7: HIGH:** Use this control to adjust the high frequency level of the Overdrive channel.

**8: LEVEL:** Use this control to adjust the output level of the Overdrive channel.

**9: CHANNEL SELECT:** Use this switch to select either channel. With the switch in the out position, the Clean channel is selected. When the switch is depressed, the Overdrive channel is selected. The adjacent LEDs illuminate to indicate which channel is active. When a footswitch is connected to the Channel / Gain Select Footswitch jack (#21), this switch is inactive and the Channel Select function is controlled by the footswitch (see #21).

**CLEAN CHANNEL:** A normal gain channel designed to give you crystal clear sounds to medium distortion.

**10: VOL:** Use this control to adjust the output level of the Clean channel.

**11: LOW:** Use this control to adjust the low frequency level of the Clean channel.

**12: MID:** Use this control to adjust the midrange frequency level of the Clean channel.

**13: HIGH:** Use this control to adjust the high frequency level of the Clean channel.

**14: DSP LEVEL:** Use this control to adjust the amount of digital effect: in its fully counter clockwise position the signal will be “dry” (without any effect). As you rotate the control clockwise the amount of effect increases.

**15: DSP SELECTOR:** Use this control to select one of the 16 built-in digital effects. A listing of the effects is shown on page 3 of this user’s guide.

**16: INSERT:** Use this jack to connect an external effects device to the amplifier. Use a stereo 1/4” male Y connector: ring = send, tip = return, sleeve = ground. (Refer to the illustration at the bottom of page 5.)

**17. EXTERNAL SPEAKER:** Use this jack to connect the amplifier to an external speaker. This jack is wired in series with the internal speaker, which remains active even when an external speaker is connected.

# CRATE **FXT65** Guitar Amp with DSP & Channel Tracking

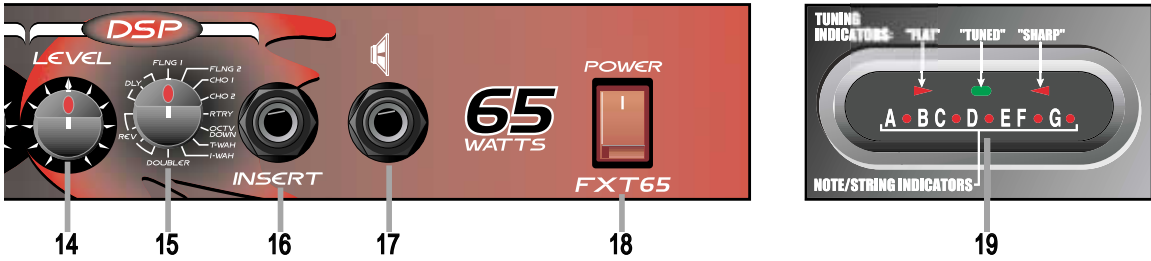

**18: POWER:** Use this switch to turn the amplifier on (top of the switch depressed) and off (bottom of the switch depressed). The switch illuminates when the power is on.

**19: ELECTRONIC TUNER (top panel):** The electronic tuner is active whenever the amplifier is turned on, providing constant, "real time" tuning. The bottom row of LEDs indicate which note (string) is being tuned. The top row of LEDs provides directional queues to facilitate quick and precise tuning of your instrument. The indicated note (string) is properly tuned when only the center LED is illuminated.

### The Rear Panel (not shown):

**20: FUSE:** The fuse protects the amplifier from damages caused by a faulty AC power source and/or other problems. If the fuse opens, replace it **ONLY** with the same size and type. If the fuse continues to fail, check the AC source – if the source is okay, contact your Crate dealer for service information.

**21: CHANNEL / GAIN SELECT FOOTSWITCH:** Use this jack to connect the 1/4" stereo plug on the footswitch cable to the three-button footswitch (supplied). This allows you to remotely switch between the Clean and Overdrive channels and between Overdrive Gain 1 and Gain 2. When a footswitch is used, the front panel Gain and Channel Select switches (#5, #9) are rendered ineffectual.

**22: DSP FOOTSWITCH:** Use this jack to connect the 1/4" mono plug on the footswitch cable to the three-button footswitch (supplied). This allows you to remotely turn the DSP on and off.

**23: AC LINE CORD:** This grounded power cord is to be plugged into a grounded power outlet, wired to current electrical codes and compatible with the voltage, power, and frequency requirements stated on the rear panel. **Do not attempt to defeat the safety ground connection.**

### Connecting to the Insert jack:

The Insert jack (#16) allows you to patch an external effects device into the amplifier prior to its power amp stage. Use Crate's STP201, STP202, or STP203 stereo-to-mono Y-cord or an adapter such as Crate's YPP117 and two 1/4" mono signal cables to connect the effect as shown to the immediate right.

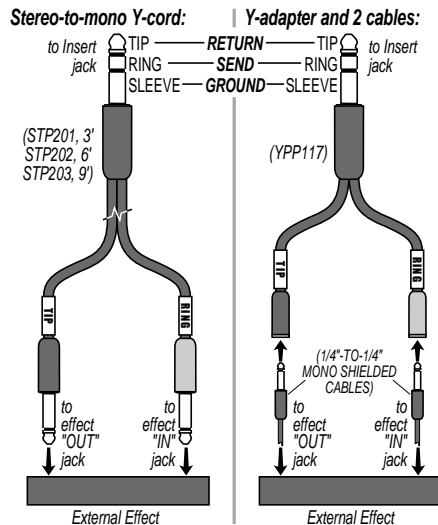

### Suggested Settings:

#### Sweet 'n Clean:

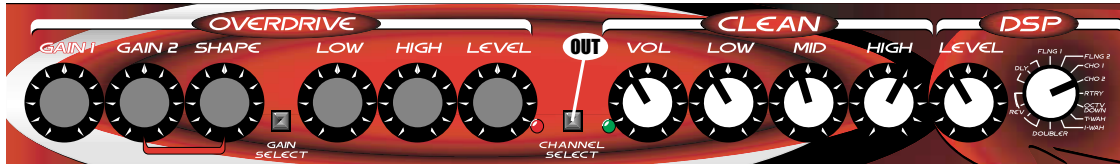

#### Just a 'Lil Nasty:

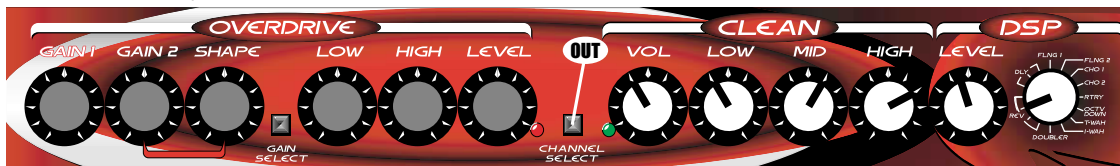

#### Politely Gritty:

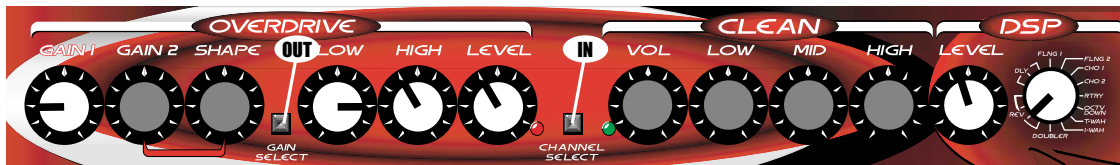

#### Octave Down 'n Dirty:

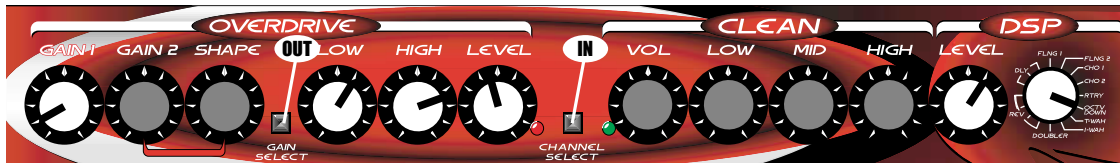

#### Wah Full House:

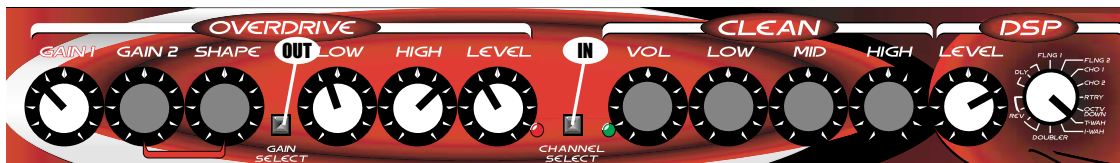

#### Mean & Obscene:

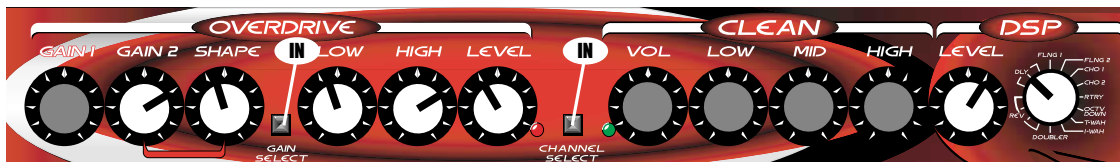

**System Block Diagram:**

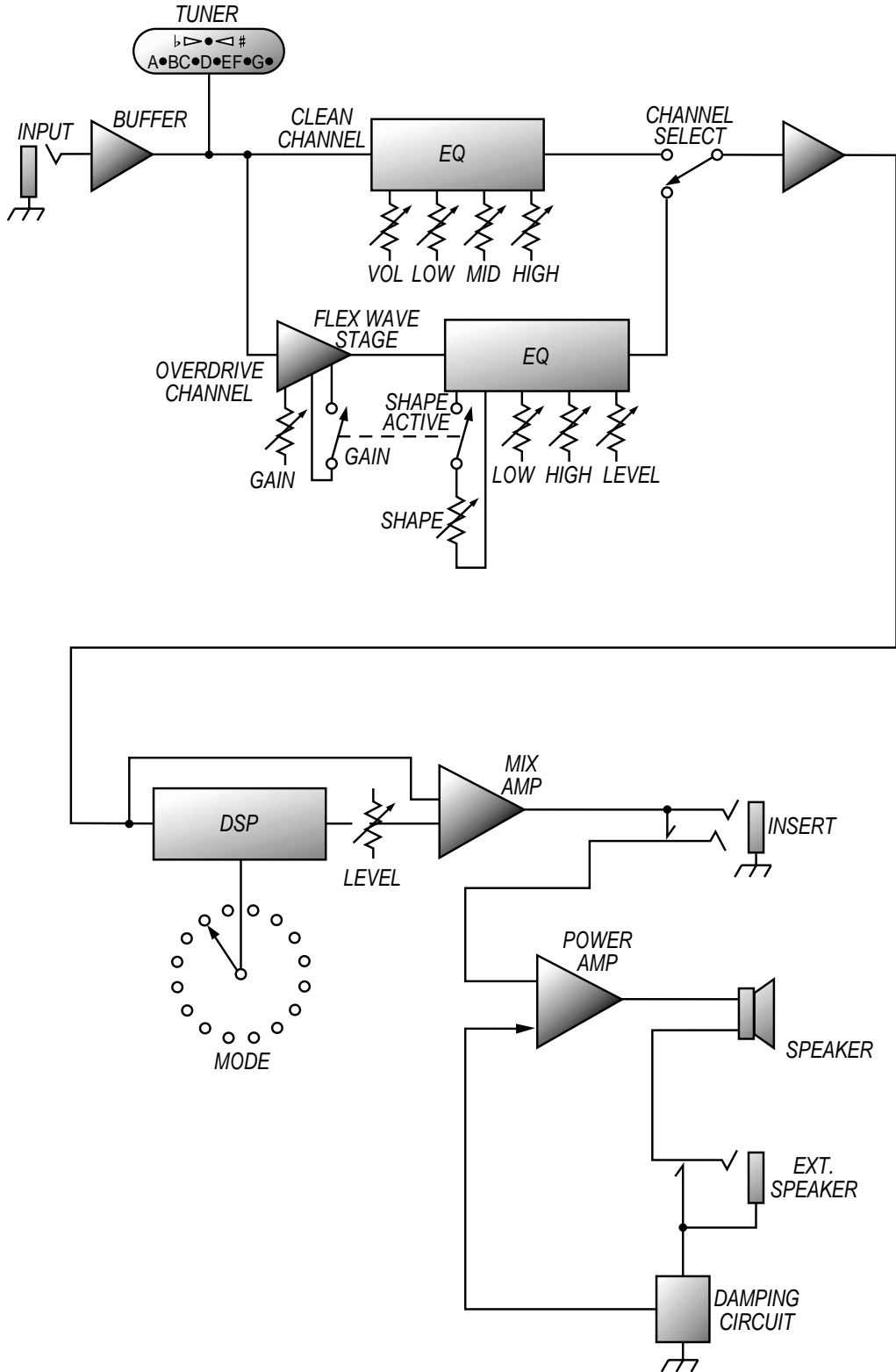

**CRATE****FXT65 Guitar Amp with DSP & Channel Tracking****FXT65 TECHNICAL SPECIFICATIONS:**

Output Power Rating	65W RMS @ 5% THD, 8Ω, 120 VAC	
Speaker Size and Rating	(1) Custom Design 12", 8Ω	
Input Impedance	470kΩ	
Total System Gain	Solo Ch	110dB, all controls @10
	Overdrive Ch	88dB, all controls @10
	Clean Ch	58dB, all controls @10
CD Input	29dB	
Maximum Input Signal Accepted	7 volts peak-to-peak	
Solo Channel	Shape Control	Proprietary Circuit
O.D. Channel	Low Control	20dB range @ 80Hz
	Mid Control	15dB range @ 1kHz
	High Control	20dB range @ 10kHz
Clean Channel	Low Control	36dB range @ 80Hz
	Mid Control	15dB range @ 800Hz
	High Control	40dB range @ 10kHz
Power Requirements	120 VAC, 60Hz, 90VA 100/115VAC, 50/60Hz, 90VA 230VAC, 50/60Hz, 90VA	
Size and Weight	17-1/2" H x 20" W x 11" D, 34 lbs.	

**The FXT65 is covered with a durable Tolex material: wipe it clean with a lint-free cloth. Never spray cleaning agents onto the cabinet. Avoid abrasive cleansers which would damage the finish.**

*Crate continually develops new products, as well as improves existing ones. For this reason, the specifications and information in this manual are subject to change without notice.*

**Declaration Of Conformity**

#34, Effective 01-01-2001

**Manufacturer's Name:**

SLM Electronics

**Production Facility:**

1901 Congressional Drive, St. Louis, MO 63146, USA

**Production Facility:**

700 Hwy 202 W, Yellville, AR 72687, USA

**Shipping Facility:**

1400 Ferguson Ave., St. Louis, MO 63133, USA

**Office Facility:**

1400 Ferguson Ave., St. Louis, MO 63133, USA

**Product Type:**

Audio Amplifier

**Complies with the following Standards:****Safety:**

EN60065, E60065, C22.2, UL6500 and/or UL813

**EMC:**

Directive 89/336/EEC, EN55103, EN55013, EN61000, and/or FCC 47CFR 15B c1A

Supplementary information provided by:

SLM Electronics - R & D Engineering  
1901 Congressional Drive, St Louis, MO 63146, USA  
Tel.: 314-569-0141, Fax: 314-569-0175



recycle

©2003 SLM Electronics, a division of St. Louis Music, Inc • 1400 Ferguson Avenue • St. Louis, MO 63133

47-475-08 • 012904

**CRATE**

www.crateamps.com



## Free Manuals Download Website

<http://myh66.com>

<http://usermanuals.us>

<http://www.somanuals.com>

<http://www.4manuals.cc>

<http://www.manual-lib.com>

<http://www.404manual.com>

<http://www.luxmanual.com>

<http://aubethermostatmanual.com>

Golf course search by state

<http://golfingnear.com>

Email search by domain

<http://emailbydomain.com>

Auto manuals search

<http://auto.somanuals.com>

TV manuals search

<http://tv.somanuals.com>