

CRATE

GT-500H ***GUITAR AMPLIFIER***



OWNER'S MANUAL



Congratulations!

You are now the proud owner of one of the newest and most versatile tube amplifiers available for the guitar, the GT-500H. This remarkable amplifier offers tremendous flexibility and power with two separate channels and silent switching for a uniquely rich palette of tonal variety and simplicity of control over your sound.

Your GT-500H amplifier is musician-made in the U.S.A. using the finest components available. Each unit is rigorously tested by skilled technicians and musicians to ensure that your amplifier is the best it can be!

In order to get the most out of your new amplifier, we strongly urge you to go over the information contained in this manual before you begin playing

And **thank you** for choosing **CRATE**®

<div style="background-color: black; color: white; padding: 2px; font-weight: bold; font-size: 0.8em;">CAUTION</div> <div style="font-size: 0.7em; margin-top: 2px;">RISK OF ELECTRIC SHOCK DO NOT OPEN</div> <p style="font-size: 0.6em; margin-top: 5px;">CAUTION: TO REDUCE THE RISK OF ELECTRIC SHOCK, DO NOT REMOVE COVER. NO USER-SERVICEABLE PARTS INSIDE. REFER SERVICING TO QUALIFIED SERVICE PERSONNEL.</p>	<div style="background-color: black; color: white; padding: 2px; font-weight: bold; font-size: 0.8em;">ATTENTION</div> <div style="font-size: 0.7em; margin-top: 2px;">RISQUE D'ELECTROCUTION NE PAS OUVRIR</div> <p style="font-size: 0.6em; margin-top: 5px;">ATTENTION: POUR REDUIRE D'ELECTROCUTION NE PAS ENLEVER LE COUVERCLE. AUCUNE PIECE INTERNE N'EST REPARABLE PAR L'UTILISATEUR. POUR TOUTE REPARATION, S'ADRESSER A UN TECHNICIEN QUALIFIE.</p>	<div style="background-color: black; color: white; padding: 2px; font-weight: bold; font-size: 0.8em;">VORSICHT</div> <div style="font-size: 0.7em; margin-top: 2px;">ELEKTRISCHE SCHLAGEGFAHR NICHT OFFENEN</div> <p style="font-size: 0.6em; margin-top: 5px;">VORSICHT: ZUR MINIMIERUNG ELEKTRISCHER SCHLAGEGFAHR NICHT DEN DECKEL ABENHMEN. INTERNE TEILE KÖNNEN NICHT VOM BENUTZER GEWARTET WERDEN. DIE WARTUNG IS QUALIFIZIERTEM WARTUNGSPERSONAL ZU ÜBERLASSEN.</p>																								
<p>THIS EQUIPMENT HAS BEEN DESIGNED AND ENGINEERED TO PROVIDE SAFE AND RELIABLE OPERATION. IN ORDER TO PROLONG THE LIFE OF THE UNIT AND PREVENT ACCIDENTAL DAMAGES OR INJURY, PLEASE FOLLOW THESE PRECAUTIONARY GUIDELINES:</p> <p>CAUTION: TO REDUCE THE RISK OF ELECTRIC SHOCK, DO NOT OPEN CHASSIS; DO NOT DEFEAT OR REMOVE THE GROUND PIN OF THE POWER CORD; CONNECT ONLY TO A PROPERLY GROUNDED AC POWER OUTLET.</p> <p>WARNING: TO REDUCE THE RISK OF FIRE OR ELECTRIC SHOCK, DO NOT EXPOSE THIS EQUIPMENT TO RAIN OR MOISTURE.</p> <p>CAUTION: NO USER-SERVICEABLE PARTS INSIDE. REFER SERVICING TO QUALIFIED SERVICE PERSONNEL.</p> <p>CAUTION: THIS UNIT IS CAPABLE OF PRODUCING HIGH SOUND PRESSURE LEVELS. CONTINUED EXPOSURE TO HIGH SOUND PRESSURE LEVELS CAN CAUSE PERMANENT HEARING IMPAIRMENT OR LOSS. USER CAUTION IS ADVISED, AND EAR PROTECTION RECOMMENDED IF UNIT IS OPERATED AT HIGH VOLUME. THE CHART BELOW SHOWS THE U.S. GOVERNMENT'S OCCUPATIONAL SAFETY AND HEALTH ADMINISTRATION (OSHA) REGULATIONS WHICH WERE IN EFFECT AT THE TIME OF THIS PUBLICATION FOR PERMISSIBLE NOISE EXPOSURE, PER 29CFR1910.95, TABLE G-16:</p> <table border="1" style="width: 100%; border-collapse: collapse; font-size: 0.8em;"> <thead> <tr> <th style="text-align: left;">SOUND LEVEL DBA, SLOW RESPONSE</th> <th style="text-align: left;">DURATION PER DAY IN HOURS</th> <th style="text-align: left;">SOUND LEVEL DBA, SLOW RESPONSE</th> <th style="text-align: left;">DURATION PER DAY IN HOURS</th> </tr> </thead> <tbody> <tr> <td>90</td> <td>8</td> <td>102</td> <td>1 - 1 1/2</td> </tr> <tr> <td>92</td> <td>6</td> <td>105</td> <td>1</td> </tr> <tr> <td>95</td> <td>4</td> <td>110</td> <td>1/2</td> </tr> <tr> <td>97</td> <td>3</td> <td>115</td> <td>1/4 or less</td> </tr> <tr> <td>100</td> <td>2</td> <td></td> <td></td> </tr> </tbody> </table> <p style="font-size: 0.7em; margin-top: 5px;">ACCORDING TO OSHA, ANY EXPOSURE IN EXCESS TO THESE AMOUNTS LISTED ABOVE COULD RESULT IN SOME HEARING LOSS.</p>			SOUND LEVEL DBA, SLOW RESPONSE	DURATION PER DAY IN HOURS	SOUND LEVEL DBA, SLOW RESPONSE	DURATION PER DAY IN HOURS	90	8	102	1 - 1 1/2	92	6	105	1	95	4	110	1/2	97	3	115	1/4 or less	100	2		
SOUND LEVEL DBA, SLOW RESPONSE	DURATION PER DAY IN HOURS	SOUND LEVEL DBA, SLOW RESPONSE	DURATION PER DAY IN HOURS																							
90	8	102	1 - 1 1/2																							
92	6	105	1																							
95	4	110	1/2																							
97	3	115	1/4 or less																							
100	2																									
<p>EXPLANATION OF GRAPHICAL SYMBOLS:</p> <div style="display: flex; justify-content: space-between;"> <div style="text-align: center;"> = "DANGEROUS VOLTAGE" "DANGER HAUTE TENSION" "GEFAHRICHE SPANNUNG" </div> <div style="text-align: center;"> = "IT IS NECESSARY FOR THE USER TO REFER TO THE INSTRUCTION MANUAL" "REFERREZ-VOUS AU MANUAL D'UTILISATION" "UNBEDINGT IN DER BEDIENUNGSANLEITUNG NACHSCHLAGEN" </div> </div>																										

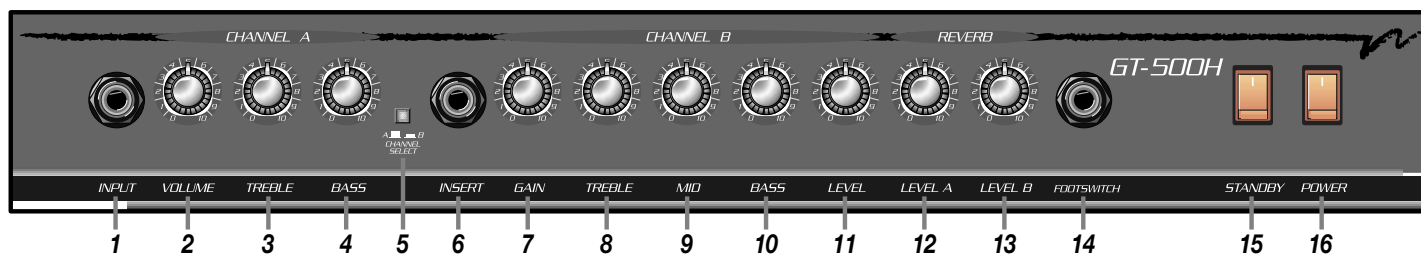

TABLE OF CONTENTS:

Features	3
The Front Panel Controls and Their Use	4
The Rear Panel	5
Connecting to the Insert Jack	5
Some Suggested Settings	6
System Block Diagram	7
Technical Specificationsback cover

Features:

- All tube operation for classic vintage growl and howl, as you want it, when you want it
- Two completely independent channels with individual gain and tone controls
- Quick, silent channel switching from the front panel **or** with footswitch (provided)
- Individual reverb return controls for each channel
- Buffered insert jack – use a stereo-to-mono “Y” cord to patch in your favorite effect(s)
- Specially designed paper bobbin output transformer for a true “vintage” sound
- Drives 8 and 16 ohm speaker cabinets with no problem and delivers lots of true vintage tone, tone, tone
- Durable tolex[®] covering and special cosmetic treatments for a unique stage appearance



The Front Panel Controls and Their Use:

1. **INPUT:** This jack accepts a high impedance signal from a guitar, bass, keyboard, etc.
2. **CHANNEL A VOLUME:** This control sets the level of Channel A. The sound is brighter at lower settings, and can be cranked up for a crunchy rhythm sound.
3. **CHANNEL A TREBLE:** This control adjusts the level of high frequency response on Channel A.
4. **CHANNEL A BASS:** This control adjusts the level of low frequency response on Channel A. (When playing at extreme volume levels, you might want to back this control down just a bit.)
5. **CHANNEL SELECT:** Silent channel switching is achieved with this button. When the footswitch is plugged in, this button is deactivated.
6. **INSERT JACK:** This jack provides a line level access point between the preamp and the power amp. The output is buffered by a single transistor. It is out of the circuit completely when nothing is plugged into it. Use a Crate Model #CYC6MS mono-to-stereo Y-cord, or a Y-adapter with extenders. For more details refer to the section "Connecting to the Insert Jack" on the following page.
7. **CHANNEL B GAIN:** Use this control to achieve sounds ranging from bluesy crunch to full tilt-hard rock rhythm. Experimenting with a combination of the gain and volume controls on the amp along with your guitar's volume controls can produce a wide variety of useable sounds.
8. **CHANNEL B TREBLE:** This control adjusts the level of the high frequency response on Channel B.
9. **CHANNEL B MID:** This control adjusts the amount of midrange frequency response on Channel B.
10. **CHANNEL B BASS:** This control adjusts the level of low frequency response on Channel B.
11. **CHANNEL B LEVEL:** The overall volume level of Channel B is controlled with this knob. When set at 2 o'clock, the power amp begins to be overdriven for true power amp distortion.
12. **CHANNEL A REVERB LEVEL:** This control adjusts the amount of reverb on Channel A.
13. **CHANNEL B REVERB LEVEL:** This control adjusts the amount of reverb on Channel B.
14. **FOOTSWITCH JACK:** Use the supplied single-button footswitch (Crate model #CFP-1) or an equivalent to achieve silent remote channel switching. Plugging in the footswitch deactivates the front panel channel switch (#5).
15. **STANDBY SWITCH:** This switch should remain turned off when the unit is first turned on in order to allow the tubes to warm up properly before high voltage is applied to them. The Standby switch should also be turned off during extended breaks in playing when the amp is left on. This will help ensure longer tube life.
16. **POWER SWITCH:** This switch applies power to the unit when switched to the on (up) position.

The Standby and Power switches light up when on.

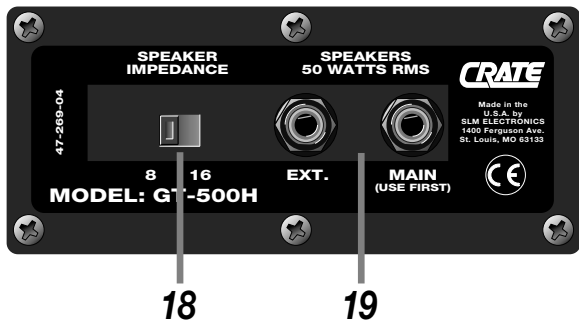

The Rear Panel:

17. AC LINE CORD (not shown): Connect the male end of this heavy duty power cord to a properly grounded AC power outlet of the correct voltage. DO NOT attempt to defeat the ground pin of the power cord! (If your amplifier was purchased outside the United States, see the rear panel serial number label for voltage and current information.)

18. IMPEDANCE SWITCH: For the best performance and least strain on the amp, you MUST match the amp's impedance to that of your speaker cabinet(s). Set the selector switch to the 8 or 16 ohm position, depending on the total impedance of your cabinets. The chart below can help you determine that impedance based on the following combinations of speakers connected in parallel.

CAB IMP.	# OF CABS	TOTAL IMP.
16 ohms	2	8 ohms
32 ohms	2	16 ohms
32 ohms	4	8 ohms

19. SPEAKER JACKS: Connect the amplifier to your speaker cabinet(s) via these jacks, using heavy-duty speaker cables (*not* instrument patch cords). Use cabinets rated at 8 ohms or higher, in combinations which never create a load lower than 8 ohms. Make sure the Impedance switch (#18) is properly set. Always use the MAIN speaker jack **first**, then connect to the EXTENSION jack if using more than one cabinet.

Connecting to the Insert Jack:

The front panel Insert jack (#6) lets you patch external effects into the GT-500H just prior to its power amp stage. When using Crate's CYC6MS stereo-to-mono Y-cord, connect its 1/4" stereo plug into the amp's Insert jack, its "send" plug into the IN jack of the effect and its "return" plug into the OUT jack of the effect.

Another method is to buy or make a stereo-to-mono Y-adaptor (such as Crate's CA11Y) and use two 1/4" signal cables to patch into the effect as shown below.

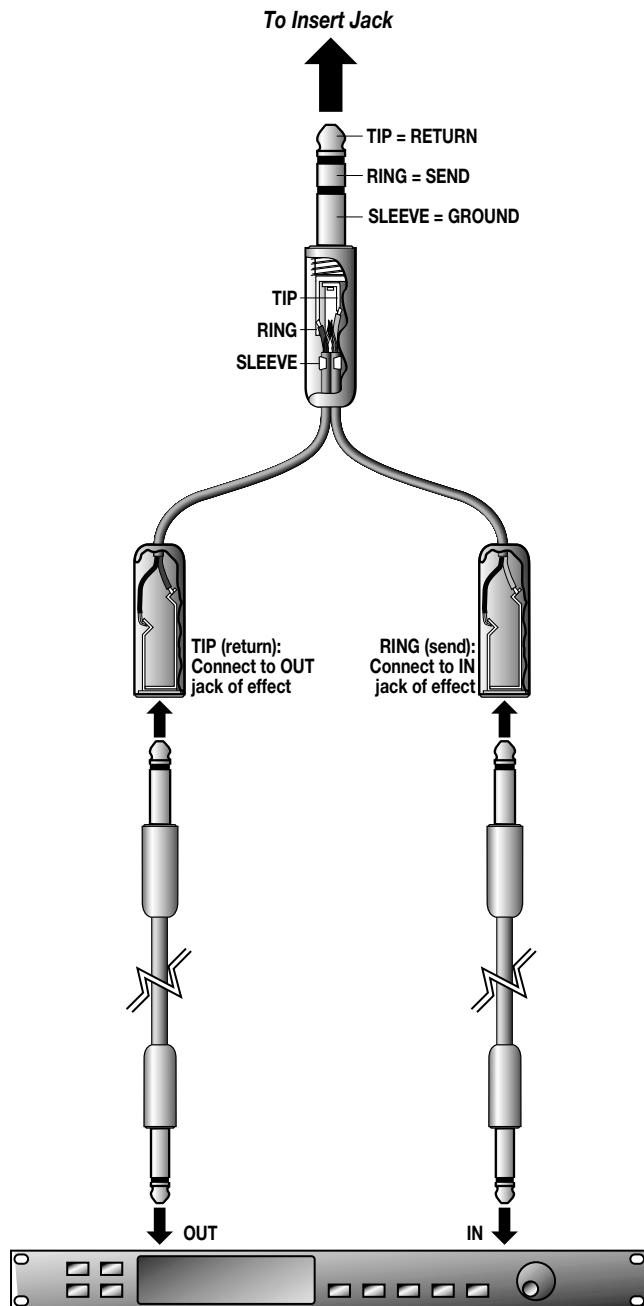



Some Suggested Settings:





System Block Diagram:

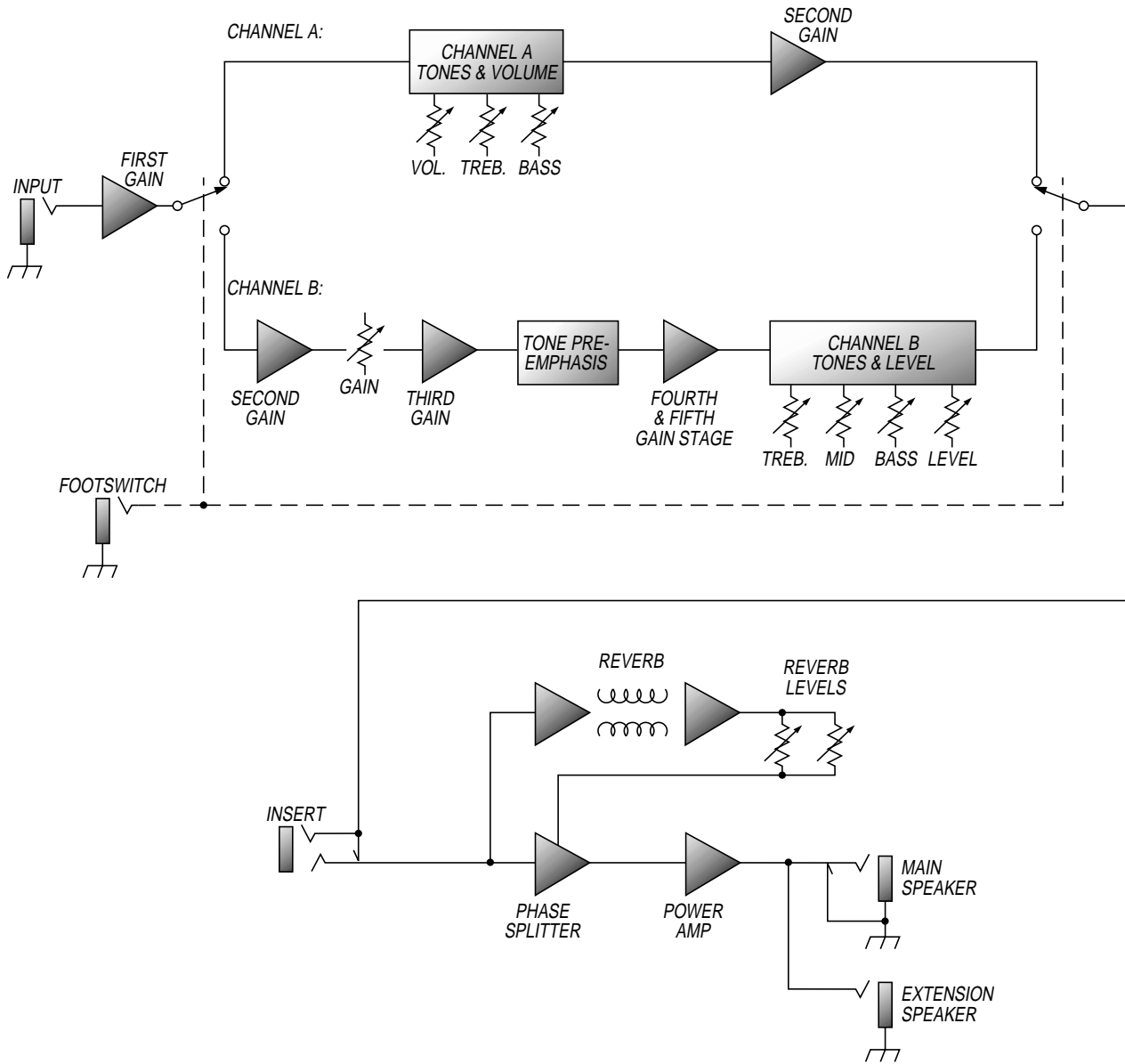

**TECHNICAL SPECIFICATIONS:**

Output Power Rating	50W RMS @ 10% THD, 8 ohm load, 120 VAC		
Input Impedance	1M ohm		
Maximum Signal Accepted	2.8V peak to peak		
Signal To Noise Ratio	Channel B:	52dB	
	Channel A:	58dB	
Gain	Channel B:	75dB	
	Channel A:	68dB	
Tone Control Range	Channel B:	Bass:	12dB, 60Hz
		Mid:	10dB, 600Hz
		Treble:	7dB, 4kHz
	Channel A:	Bass:	20dB, 70Hz
		Treble:	16dB, 2kHz
Line Out Level	375mV RMS @ full power output		
Tube Type	Preamp: (4) 12AX7 Power Amp: (4) EL84/6BQ5		
Power Requirements	120VAC, 60Hz, 110VA 100/115VAC, 50/60Hz, 110VA 230VAC, 50/60Hz, 110VA		
Size and Weight	11"H x 21.25"W x 11.25"D, 35 lbs.		

The GT-500H is covered with a durable black Tolex[®] material. To keep the cabinet in top condition, wipe it clean with a damp lint-free cloth to remove dirt and road film. Never spray cleaning agents directly onto the cabinet, and stay away from abrasive cleansers which could damage the finish.

*Crate continually develops new products, as well as improves existing ones.
For this reason, the specifications and information in this publication
are subject to change without notice.*



Free Manuals Download Website

<http://myh66.com>

<http://usermanuals.us>

<http://www.somanuals.com>

<http://www.4manuals.cc>

<http://www.manual-lib.com>

<http://www.404manual.com>

<http://www.luxmanual.com>

<http://aubethermostatmanual.com>

Golf course search by state

<http://golfingnear.com>

Email search by domain

<http://emailbydomain.com>

Auto manuals search

<http://auto.somanuals.com>

TV manuals search

<http://tv.somanuals.com>