

CRATE[®]

KX-160 Keyboard Amplifier



OWNER'S MANUAL

Congratulations!

You are now the proud owner of the Crate KX-160 keyboard amplifier. This versatile and great sounding amp features a 15" Crate Custom woofer and a Foster bullet tweeter housed in a ported tuned enclosure. Each of the four discrete channels has its own gain and reverb/effect control while two of the channels have separate low and high rotary EQ controls as well. The Master section features a 7-band graphic equalizer, balanced and unbalanced line out jacks with a level control, two effects loops and footswitch-controllable reverb.

Like all Crate products, your KX-160 is Musician Made in the U.S.A., using only the best components. Extensive testing at the hands (and ears) of skilled technicians and musicians insures you that this amplifier is the absolute best it can be.

In order to get the most out of your new amplifier, we strongly urge you to go over the information contained in this manual before you begin playing.

And ***thank you*** for choosing **CRATE[®]**

CRATE® KX-160 Keyboard Amplifier

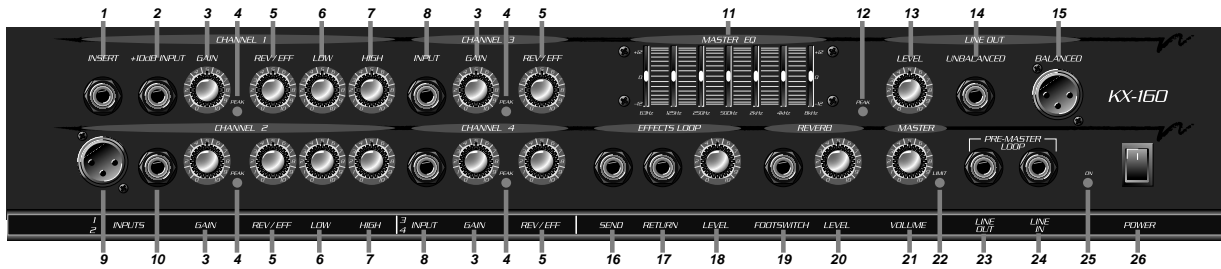

1: Insert jack allows the capacity to patch into the KX-160 via a stereo “Y” cord, with the tip of the plug being line out, the ring being line in and the sleeve being ground.

2: +10dB Input jack accepts a standard 1/4” phone plug, but is three times more sensitive than the 0dB inputs (#8, 10), mainly suitable for low level signals from electric pianos as well as high level outputs from synthesizers.

3: Gain control sets the gain for each channel independently.

4: Peak Indicator LED lights when the corresponding input stage of the each channel is within 10dB of clipping. Adjust the Gain controls (#3) until a strong signal from the instrument or signal source causes this LED to flash.

5: Reverb/Effects Send controls are used to set the amount of reverb, as well as the amount of signal sent to the Effects Send jack (#16) for each channel.

6: Low controls for Channels 1 and 2 increase or decrease the bass of the respective channel.

7: High controls for Channels 1 and 2 increase or decrease the treble for the respective channel.

8: 0dB Input jacks for Channels 3 and 4 accept standard 1/4” phone jacks, and are suitable for a signal source from synthesizers.

9: Low Z Input jack will accept a low impedance balanced input, such as a microphone, and may be used in conjunction with the High Z Input (#10).

10: High Z Input also provides Channel 2 with a 0dB balanced input jack. It is suitable for a signal source from synthesizers.

11: Master EQ has seven bands and enables you to shape the tonality of the KX-160 to suit room acoustics. Frequencies from 63Hz to 8kHz may be boosted by moving the sliders up or cut by moving them down.

12: EQ Peak Indicator LED will illuminate whenever the Master EQ section is within 10dB of clipping. To avoid clipping, reduce the amount of EQ boost or channel Gain.

13: Line Out Level control belongs to a post-EQ, pre-master circuit which provides both an unbalanced and balanced output. The Level control will adjust the amount of gain for both output jacks and is independent of the Master Volume (#21).

14: Unbalanced Line Out jack is a high impedance line output which will accept a standard 1/4” plug and is suitable for connecting the KX-160 to another amplifier, tape deck, etc.

15: Balanced Line Out jack a low impedance balanced output for connection to an external amplifier or mixer with balanced inputs.

16: Effects Loop Send jack, when used in conjunction with the Return jack (#17), provides a pre-EQ effects loop. The pre-EQ circuitry reduces the unwanted noise associated with most external effects devices. This output can be connected to the line input of your external effects device.

17: Effects Loop Return jack can be connected to the line output of your external effects device.

18: Effects Loop Level control is a master volume for the Effects Loop with which you can increase or decrease the amount of effect desired.

19: Reverb Footswitch jack may be used to connect the Reverb master circuit to a footswitch on/off unit.

20: Reverb Level acts as the reverb master control.

21: Master Volume controls the total output level of the KX-160.

22: Master Limit Indicator LED is lit when the limiting circuitry is activated. (The limit circuit prevents the amplifier from clipping, or distorting.) Also, the LED indicates when the maximum undistorted power available has been attained. It is normal for this LED to flicker on and off; however, it should not illuminate constantly. If it does so, reduce the Master Volume control (#21).

23, 24: Pre-Master Line Out and Line In jacks form a pre-master circuit which can be used as an extra effects loop, etc., thus adding to the versatility of the KX-160. The Line Out jack (#23) should be connected to the input of the external device and the Line In jack (#24) should be connected to the output of the external device.

25: Power Indicator LED will be lit when the unit is turned on.

26: Power Switch turns the AC power on and off.

27: Power Cord (rear panel, not shown): Your KX-160 is equipped with a heavy-duty grounded three-wire power cord. Be sure this cord is properly plugged into a safely wired grounded 120 volt, 60Hz AC power outlet before use. (If your KX-160 was purchased outside the United States, refer to the rear panel for power ratings.) For your safety, never attempt to defeat the ground connection on this cord.

28: Speaker Output jacks (rear panel, not shown): Any load equal to no less than 2 ohms may be connected to the speaker jacks. If more than one jack is used, the total load must be no less than 2 ohms. The standard internal speaker configuration is equal to 4 ohms. The speaker jacks are wired in parallel with the internal speakers, which means that an additional 4 ohm load may be connected for a total of 2 ohms. **(Please see “Important Note About Speaker Jacks” below.)**

IMPORTANT NOTE ABOUT SPEAKER JACKS:

In some areas 1/4” speaker jacks are not acceptable for use on amplifiers capable of high output power levels. For this reason the 1/4” jacks on your KX-160 may be factory sealed – in such cases, use the Speakon® jack provided for connecting the amplifier to external speakers. Use heavy duty speaker cables terminated with the proper connectors.

CRATE[®] KX-160 Keyboard Amplifier

SYSTEM BLOCK DIAGRAM:

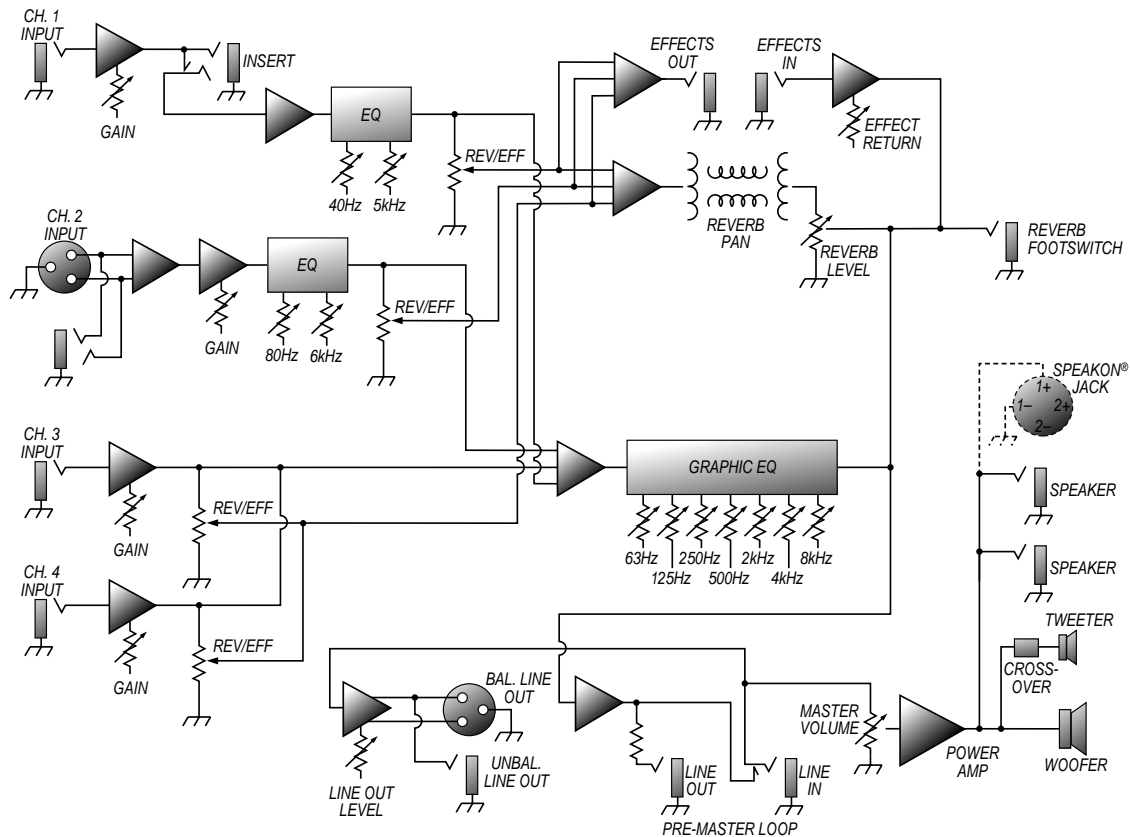

The KX-160 is covered with a durable black Tolex material: wipe it clean with a lint-free cloth. Never spray cleaning agents onto the cabinet. Avoid abrasive cleansers which would damage the finish.

El KX-160 esta cubierto con un material durable Tolex: limpielo con una toalla seca. Nunca rocíe el gabinete con sustancias limpiadoras. Evite usar materiales abrasivos con los cuales pueda danar el acabado.

Le KX-160 est couvert avec «Tolex» un recêtement noir et durable. Essayez cette matière avec une toile propre et sans charpie. Ne pulvérisez jamais les agents de nettoyage sur l'appareil. Evitez les nettoyeurs abrasifs qui peuvent endommager le «Tolex.»

Crate continually develops new products, as well as improves existing ones. For this reason, the specifications and information in this Crate manual are subject to change without notice.







Crate continuamente desarrolla nuevos productos, así como también mejora los existentes. Por esta razón, las especificaciones é información incluidos en este manual están sujetos a cambios sin previo aviso.

Crate développe continuellement des nouveaux produits, ainsi d'améliorer ceux qui existe. Pour cette raison les spécifications et les informations dans ce manuel peuvent se changer sans préavis.

CRATE[®] KX-160 Keyboard Amplifier

KX-160 TECHNICAL SPECIFICATIONS:

Maximum Signal Accepted	Ch's 1, 3 and 4: 10 volts peak to peak Ch. 2 High Z: 15 volts peak to peak; Low Z: 10 volts peak to peak
Input Power Requirements	120 VAC, 60Hz, 205VA 100/110 VAC, 50/60Hz, 205VA 230 VAC, 50/60Hz, 205VA
Nominal Input Impedance	Ch's 1, 3 and 4: 22k ohms Ch. 2 High Z: 10k ohms; Low Z: 600 ohms
Input Sensitivity	Ch. 1: 25mV; Ch. 2 High Z: 85mV; Low Z: 4mV Ch. 3: 85mV; Ch. 4: 85mV
Signal To Noise Ratio	75dB w/all gains @ 10, all reverbs @ 0, EQ flat, Master Volume @ 10
Output Power Rating	160 watts @ 5% THD w/4 ohm load, 220 watts @ 2 ohms
EQ Section	Ch. 1: ±12dB @ 40Hz, 2.5kHz; Ch. 2: ±12dB @ 70Hz, 5kHz
Master EQ	±12dB @ 63Hz, 125Hz, 250Hz, 500Hz, 2kHz, 4kHz and 8kHz
Line In/Line Out	1 volt RMS
Limiter Range	20dB, maximum distortion 1%
Speaker Size and Rating	15" Crate Custom Design w/2.5" voice coil and 56 oz. magnet 4"x4" Bullet Horn w/1" voice coil, replaceable phenolic diaphragm and 8 oz. magnet
Cabinet Size and Weight	24.75" H x 24.5" W x 16" D, 82 lbs.

 CAUTION RISK OF ELECTRIC SHOCK DO NOT OPEN	<p>THIS EQUIPMENT HAS BEEN DESIGNED AND ENGINEERED TO PROVIDE SAFE AND RELIABLE OPERATION. IN ORDER TO PROLONG THE LIFE OF THE UNIT AND PREVENT ACCIDENTAL DAMAGES OR INJURY, PLEASE FOLLOW THESE PRECAUTIONARY GUIDELINES:</p> <p>CAUTION: TO REDUCE THE RISK OF ELECTRIC SHOCK, DO NOT OPEN CHASSIS; DO NOT DEFEAT OR REMOVE THE GROUND PIN OF THE POWER CORD; CONNECT ONLY TO A PROPERLY GROUNDED AC POWER OUTLET.</p> <p>WARNING: TO REDUCE THE RISK OF FIRE OR ELECTRIC SHOCK, DO NOT EXPOSE THIS EQUIPMENT TO RAIN OR MOISTURE.</p> <p>CAUTION: NO USER-SERVICEABLE PARTS INSIDE. REFER SERVICING TO QUALIFIED SERVICE PERSONNEL.</p> <p>CAUTION: OUR AMPLIFIERS ARE CAPABLE OF PRODUCING HIGH SOUND PRESSURE LEVELS. CONTINUED EXPOSURE TO HIGH SOUND PRESSURE LEVELS CAN CAUSE PERMANENT HEARING IMPAIRMENT OR LOSS. USER CAUTION IS ADVISED AND EAR PROTECTION IS RECOMMENDED IF UNIT IS OPERATED AT HIGH VOLUME.</p>	<p>ESTE APARATO HA SIDO DISEÑADO Y CONSTRUÍDO PARA PROVEER AÑOS DE OPERACION SEGURA Y CONFIABLE. PARA PROLONGAR LA VIDA DE ESTA UNIDAD E IMPEDIR DAÑOS ACCIDENTALES POR FAVOR SIGA ESTAS INSTRUCCIONES PREVENTIVAS:</p> <p>PRECAUCION: PARA DISMINUIR EL RIESGO DE DESCARGAS ELECTRICAS: (1) NO ABRA LA CUBIERTA, (2) NO ES RECOMENDABLE REMOVER O DESACTIVAR LA PATA DEL POLO A TIERRA DEL CABLE DE CORRIENTE. CONECTE CORRECTAMENTE A UNA TOMA DE CORRIENTE A TIERRA.</p> <p>ADVERTENCIA: PARA EVITAR DESCARGAS EL ECTRICAS O PELIGRO DE INCENDIO, NO DEJE ESTE APARATO EXPUESTO A LA LLUVIA O HUMEDAD.</p> <p>PRECAUCION: NO HAY PIEZAS ADENTRO QUE EL USUARIO PUEDE REPARAR. DEJE TODO MANTENIMIENTO A LOS TÉCNICOS CALIFICADOS.</p> <p>PRECAUCION: NUESTROS AMPLIFICADORES PUEDEN PRODUCIR NIVELES DE PRESION DE SONIDO ALTO. EXPOSICION CONTINUADA A LOS NIVELES DE PRESION DE SONIDO ALTO PUEDE CAUSA DANO PERMANENTE A SU OIDO. ES ACONSEJADO QUE USE PRECAUCIONAL USUARIO Y ES RECOMENDADO PROTECCION PARA LOS OIDOS SI LA UNIDAD ES OPERADA A VOLUMEN ALTO.</p>	<p>CET ÉQUIPEMENT AVAIT ÉTÉ INVENTÉ ET ARRANGÉ POUR POURVOIR DES ANNÉES D'USAGE SAUF ET SÛR. POUR PROLONGER LA VIE DE CET APPAREIL ET POUR EMPÊCHER LES DOMMAGES ET LES TORTS ACCIDENTELS, SUIVEZ LES INSTRUCTIONS DE PRÉCAUTION.</p> <p>AVERTISSEMENT: POUR RÉDUIRE LES RISQUES D'UN FEU OU D'ÉLECTROCUTION, N'EXPOSEZ PAS L'APPAREIL À LA PLUIE OU À LA MOI-TEUR.</p> <p>ATTENTION: IL N'Y A PAS D'ÉLÉMENTS RÉPARABLES DANS L'APPAREIL. CONSULTER UN TECHNICIEN QUALIFIÉ POUR LES RÉPARATIONS.</p> <p>ATTENTION: NOS AMPLIFICATEURS SONT CAPABLES DE LA PRODUCTION DES NIVEAUX DE SON D'UNE HAUTE PRESSION. L'EXPOSITION CONTINUE AUX CES NIVEAUX PEUT CAUSER LA SURDITÉ PERMANENTE. LA PRUDENCE EST ADVISÉ À UTILISATEUR ET LA PROTECTION DES OREILLES EST RECOMMANDÉ SI L'APPAREIL EST UTILISÉ À UN HAUT NIVEAU DE VOLUME.</p>
 PRECAUCION RIESGO DE CORRIENTAZO NO ABRA			
 ATTENTION RISQUE D'ELECTROCUTION NE PAS OUVRIIR			
 VORSICHT ELEKTRISCHE SCHLAGEGFAHR NICHT OFFENEN			
EXPLANATION OF GRAPHICAL SYMBOLS: EXPLICACION DE SIMBOLOS GRAFICOS: EXPLICATION DES SYMBOLES GRAPHIQUES:	 = "DANGEROUS VOLTAGE" "VOLTAJE PELIGROSO" "DANGER HAUTE TENSION" "GEFAHLICHE SPANNUNG"	 = "IT IS NECESSARY FOR THE USER TO REFER TO THE INSTRUCTION MANUAL." "ES NECESARIO QUE EL USUARIO SE REFIERA AL MANUAL DE INSTRUCCIONES." "REFERREZ-VOUS AU MANUAL D'UTILISATION" "UNBEDINGT IN DER BEDIENUNGSANLEITUNG NACHSCHLAGEN"	

CRATE[®]
www.crateamps.com



©1997 SLM ELECTRONICS, A DIVISION OF ST. LOUIS MUSIC, 1400 FERGUSON, ST. LOUIS, MO. 63133
P/N 47-544-52 • 06/97

Free Manuals Download Website

<http://myh66.com>

<http://usermanuals.us>

<http://www.somanuals.com>

<http://www.4manuals.cc>

<http://www.manual-lib.com>

<http://www.404manual.com>

<http://www.luxmanual.com>

<http://aubethermostatmanual.com>

Golf course search by state

<http://golfingnear.com>

Email search by domain

<http://emailbydomain.com>

Auto manuals search

<http://auto.somanuals.com>

TV manuals search

<http://tv.somanuals.com>