

CRATE

ST. LOUIS MISSOURI USA

VC-6112/6210/6212

Vintage Club Amplifier



OWNER'S MANUAL

Congratulations!

You are now the proud owner of one of the newest and most versatile tube amplifiers available for the guitar! The CRATE Vintage Club Series offers flexibility and portability with two separate channels for a uniquely rich palette of tonal variety and simplicity of control over your sound.

Your CRATE Vintage Club Series amplifier is musician-made in the U.S.A. using the finest components available. Each unit is rigorously tested by skilled technicians and musicians to ensure that your amplifier is the best it can be!

In order to get the most out of your new amplifier, we strongly urge you to go over the information contained in this manual before you begin playing

And **thank you** for choosing **CRATE**

<div style="background-color: black; color: white; padding: 2px; font-weight: bold; font-size: 0.8em;">CAUTION</div> <div style="font-size: 0.7em; margin-top: 2px;">RISK OF ELECTRIC SHOCK DO NOT OPEN</div> <p style="font-size: 0.6em; margin-top: 5px;">CAUTION: TO REDUCE THE RISK OF ELECTRIC SHOCK, DO NOT REMOVE COVER. NO USER-SERVICEABLE PARTS INSIDE. REFER SERVICING TO QUALIFIED SERVICE PERSONNEL.</p>	<div style="background-color: black; color: white; padding: 2px; font-weight: bold; font-size: 0.8em;">ATTENTION</div> <div style="font-size: 0.7em; margin-top: 2px;">RISQUE D'ELECTROCUTION NE PAS OUVRIR</div> <p style="font-size: 0.6em; margin-top: 5px;">ATTENTION: POUR REDUIRE D'ELECTROCUTION NE PAS ENLEVER LE COUVERCLE. AUCUNE PIECE INTERNE N'EST REPARABLE PAR L'UTILISATEUR. POUR TOUTE REPARATION, S'ADRESSER A UN TECHNICIEN QUALIFIE.</p>	<div style="background-color: black; color: white; padding: 2px; font-weight: bold; font-size: 0.8em;">VORSICHT</div> <div style="font-size: 0.7em; margin-top: 2px;">ELEKTRISCHE SCHLAGEGFAHR NICHT OFFENEN</div> <p style="font-size: 0.6em; margin-top: 5px;">VORSICHT: ZUR MINIMIERUNG ELEKTRISCHER SCHLAGEGFAHR NICHT DEN DECKEL ABENHMEN. INTERNE TEILE KÖNNEN NICHT VOM BENUTZER GEWARTET WERDEN. DIE WARTUNG IS QUALIFIZIERTEM WARTUNGSPERSONAL ZU ÜBERLASSEN.</p>																								
<p>THIS EQUIPMENT HAS BEEN DESIGNED AND ENGINEERED TO PROVIDE SAFE AND RELIABLE OPERATION. IN ORDER TO PROLONG THE LIFE OF THE UNIT AND PREVENT ACCIDENTAL DAMAGES OR INJURY, PLEASE FOLLOW THESE PRECAUTIONARY GUIDELINES:</p> <p>CAUTION: TO REDUCE THE RISK OF ELECTRIC SHOCK, DO NOT OPEN CHASSIS; DO NOT DEFEAT OR REMOVE THE GROUND PIN OF THE POWER CORD; CONNECT ONLY TO A PROPERLY GROUNDED AC POWER OUTLET.</p> <p>WARNING: TO REDUCE THE RISK OF FIRE OR ELECTRIC SHOCK, DO NOT EXPOSE THIS EQUIPMENT TO RAIN OR MOISTURE.</p> <p>CAUTION: NO USER-SERVICEABLE PARTS INSIDE. REFER SERVICING TO QUALIFIED SERVICE PERSONNEL.</p> <p>CAUTION: THIS UNIT IS CAPABLE OF PRODUCING HIGH SOUND PRESSURE LEVELS. CONTINUED EXPOSURE TO HIGH SOUND PRESSURE LEVELS CAN CAUSE PERMANENT HEARING IMPAIRMENT OR LOSS. USER CAUTION IS ADVISED, AND EAR PROTECTION RECOMMENDED IF UNIT IS OPERATED AT HIGH VOLUME. THE CHART BELOW SHOWS THE U.S. GOVERNMENT'S OCCUPATIONAL SAFETY AND HEALTH ADMINISTRATION (OSHA) REGULATIONS WHICH WERE IN EFFECT AT THE TIME OF THIS PUBLICATION FOR PERMISSIBLE NOISE EXPOSURE, PER 29CFR1910.95, TABLE G-16:</p> <table border="1" style="margin: 5px auto; border-collapse: collapse; font-size: 0.8em;"> <thead> <tr> <th>SOUND LEVEL DBA, SLOW RESPONSE</th> <th>DURATION PER DAY IN HOURS</th> <th>SOUND LEVEL DBA, SLOW RESPONSE</th> <th>DURATION PER DAY IN HOURS</th> </tr> </thead> <tbody> <tr> <td>90</td> <td>8</td> <td>102</td> <td>1 - 1 1/2</td> </tr> <tr> <td>92</td> <td>6</td> <td>105</td> <td>1</td> </tr> <tr> <td>95</td> <td>4</td> <td>110</td> <td>1/2</td> </tr> <tr> <td>97</td> <td>3</td> <td>115</td> <td>1/4 or less</td> </tr> <tr> <td>100</td> <td>2</td> <td></td> <td></td> </tr> </tbody> </table> <p style="font-size: 0.7em; margin-top: 5px;">ACCORDING TO OSHA, ANY EXPOSURE IN EXCESS TO THESE AMOUNTS LISTED ABOVE COULD RESULT IN SOME HEARING LOSS.</p>			SOUND LEVEL DBA, SLOW RESPONSE	DURATION PER DAY IN HOURS	SOUND LEVEL DBA, SLOW RESPONSE	DURATION PER DAY IN HOURS	90	8	102	1 - 1 1/2	92	6	105	1	95	4	110	1/2	97	3	115	1/4 or less	100	2		
SOUND LEVEL DBA, SLOW RESPONSE	DURATION PER DAY IN HOURS	SOUND LEVEL DBA, SLOW RESPONSE	DURATION PER DAY IN HOURS																							
90	8	102	1 - 1 1/2																							
92	6	105	1																							
95	4	110	1/2																							
97	3	115	1/4 or less																							
100	2																									
<p>EXPLANATION OF GRAPHICAL SYMBOLS:</p> <div style="display: flex; justify-content: space-around; align-items: center;"> <div style="text-align: center;"> = "DANGEROUS VOLTAGE" "DANGER HAUTE TENSION" "GEFAHRLICHE SPANNUNG" </div> <div style="text-align: center;"> = "IT IS NECESSARY FOR THE USER TO REFER TO THE INSTRUCTION MANUAL" "REFERREZ-VOUS AU MANUAL D'UTILISATION" "UNBEDINGT IN DER BEDIENUNGSANLEITUNG NACHSCHLAGEN" </div> </div>																										

TABLE OF CONTENTS:

Features3
The Front Panel Controls and Their Use4
The Rear Panel5
Connecting to the Insert Jack5
Some Suggested Settings6
System Block Diagram7
Technical Specificationsback cover

Features:

- *All tube operation*
- *Two completely independent channels with individual gain and tone controls*
- *Channel switching from the front panel **or** footswitch (supplied)*
- *Individual reverb return controls for each channel*
- *Effects Loop for virtually noise-free connection of your favorite effect(s) – controllable by a footswitch (supplied)*
- *Specially designed paper bobbin output transformer for a true “vintage” sound*
- *Specially designed speakers for a distinctive harmonic richness and TONE, TONE, TONE!!!*
- *Durable tolex® covering and special cosmetic treatments for a unique stage appearance*

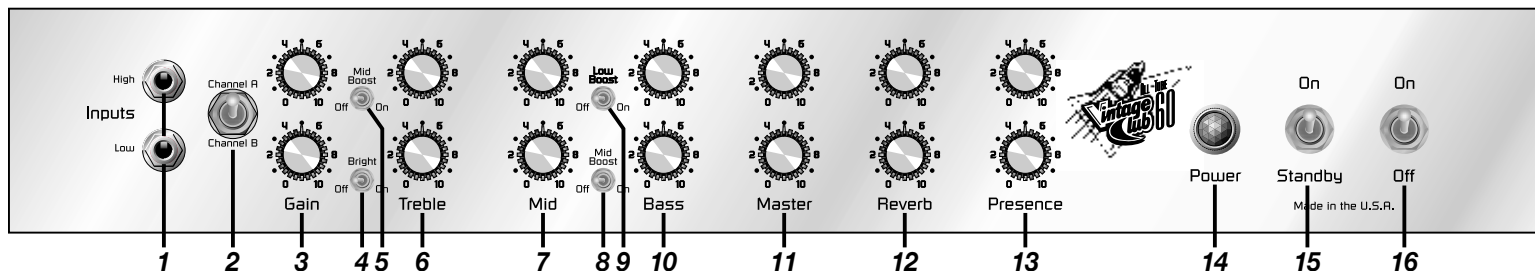

The Front Panel Controls and Their Use:

1. **INPUT JACKS:** The **High** input is a direct connection for “standard” electric guitars. The **Low** input is padded 6dB and is best suited for guitars with “hot” pickups or on-board active electronics. (Use a high quality shielded instrument cable.)
2. **CHANNEL SWITCH:** Toggle this switch to the desired channel: up for Channel A, down for Channel B. A footswitch also may be used to select channels, in which case this switch is bypassed – see #25, rear panel.
3. **GAIN CONTROLS:** These controls govern the amount of signal going to the output stage of the amplifier. Channel A Gain offers a range of sounds from clean to a bluesy crunch; Channel B from a slight crunch to full tilt screaming distortion.
4. **BRIGHT SWITCH:** Toggle this switch to the ON position to boost the upper register of Channel B.
5. **MID BOOST SWITCH:** Toggle this switch to the ON position to boost the midrange response of Channel A.
6. **TREBLE CONTROLS:** These controls adjust the high frequency levels for each channel.
7. **MID CONTROLS:** These controls adjust the midrange levels for each channel.
8. **MID BOOST SWITCH:** Toggle this switch to the ON position to boost the midrange response of Channel B.
9. **LOW BOOST SWITCH:** Toggle this switch to the ON position to boost the low end response of Channel A.
10. **BASS CONTROLS:** These controls adjust the low end levels for each channel.
11. **MASTER CONTROLS:** These controls govern the output volume levels of each channel.
12. **REVERB CONTROLS:** These controls govern the amount of reverb applied to each channel.
13. **PRESENCE CONTROLS:** These controls govern the upper-high frequencies for each channel, allowing an enhancement to the sound beyond the Treble and Mid controls.
14. **POWER LAMP:** This dual color jewel lamp glows when the amp is turned on – an amber color indicates Channel A, a red color indicates Channel B.
15. **STANDBY SWITCH:** Toggle this switch to the ON position to activate the amplifier – once the power switch (#16) has been on for at least 30 seconds. (This allows the tubes to come up to a safe operating temperature before use.) The amp should be set in the Standby mode (switch down) during extended breaks to help promote longer tube life.
16. **POWER SWITCH:** Toggle this switch to the ON position to turn on the amplifier.

NOTE: Always turn the power switch **ON FIRST, OFF LAST**. Use the Standby switch (toggled to the Standby position) when first turning the amp on as well as during breaks.

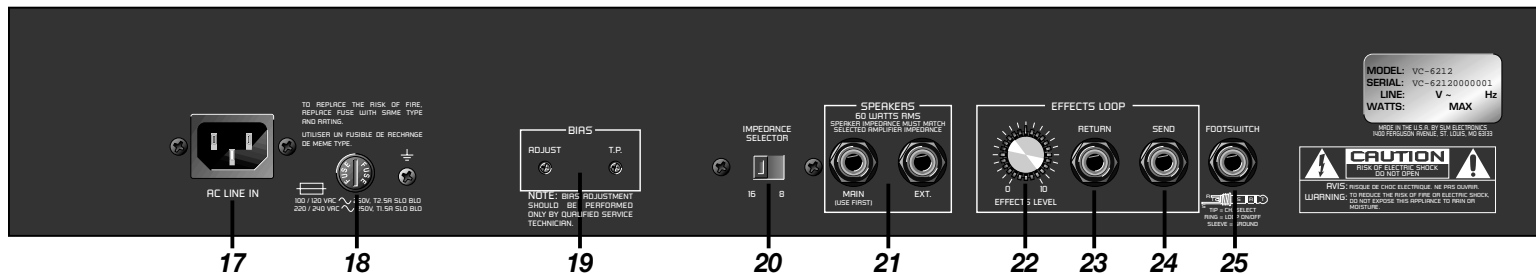

The Rear Panel:

- 17. AC LINE IN:** Firmly plug the female end of the supplied power cord into this socket, pushing it in until it is fully seated. Plug the male end of the cord into a properly grounded AC outlet of the correct voltage. **DO NOT DEFEAT THE GROUND PIN OF THE AC PLUG!** Use only the supplied power cord. If the amplifier is to be used outside of the United States, see your authorized Crate dealer for information about alternate line cords and power converters if needed.
- 18. FUSE:** This fuse protects the amplifier against damages caused by overload conditions in the unit. If the fuse blows, replace it only with the same size and type as indicated on the rear panel. If the fuse blows continually, the line voltage may be incorrect, or the amp may need servicing.
- 19. BIAS ADJUST / BIAS TEST POINT:** *For qualified Service Personnel only!* (All others please just ignore these internal Bias adjustment potentiometers.)
- 20. IMPEDANCE SWITCH:** For the best performance and least strain on the amp, you **MUST** match the amp's impedance to that of your speaker cabinet(s). Set the selector switch to the 8 or 16 ohm position, depending on the total impedance of your cabinets. The chart below can help you determine that impedance based on the following combinations of speakers connected in parallel.

CAB IMP.	# OF CABS	TOTAL IMP.
16 ohms	2	8 ohms
32 ohms	2	16 ohms
32 ohms	4	8 ohms

- 21. SPEAKER JACKS:** The amplifier is shipped from the factory with its internal speaker connected to Main speaker jack. An second cabinet may be connected to the Ext. jack, as long as the Impedance switch (#20) is properly set. If an external speaker cabinet is to be *without* the internal speaker, unplug the internal speaker cable from the amplifier and connect the external speaker to the Main jack. (When reconnecting the internal speaker, be sure to use the *Main* speaker jack!

- 22. EFFECTS LEVEL CONTROL:** Use this knob to set the input level of the signal from the Effects Loop Return jack (#23). The Effects Loop Send level is adjusted by the Master volume controls (#11).
 - 23. EFFECTS LOOP RETURN JACK:** Connection *from* an external effects device is made via this jack. Connect a shielded instrument patch cord from the output jack of the effect to the return jack. The return jack also doubles as a "power amp in" jack, to feed a line-level signal directly into the internal power amp. This is useful when "slaving" two amplifiers together. When using in this mode (slaving), make sure the front panel Master volume controls are all the way down (at "0").
 - 24. EFFECTS LOOP SEND JACK:** Connection *to* an external effects device is made via this jack. Connect a shielded instrument patch cord from the send jack to the input jack of the effect. The send jack also doubles as a "preamp out" jack, to feed a post-eq signal to a mixing board, recording console or external amplifier.
- NOTE: Effects loop operation is parallel with the signal path. Mix controls on the effects should be set to 100% (full wet). If no effects are connected to the Effects Loop, the Effects Level control (#22) acts as an extra volume boost which can be activated by the footswitch. For the best signal to noise ratio when NOT using the effects loop, keep the Effects Level control (#22) set to "0".
- 25. FOOTSWITCH JACK:** Connect the supplied two button footswitch for control of channel switching and the effects loop on/off. The tip of the jack is for channel switching; the ring is for effects. When a footswitch is connected here, the front panel channel select switch is disabled.

Some Suggested Settings:

Nice 'n Clean:



Good 'n Crunchy:



Jazz Tone:

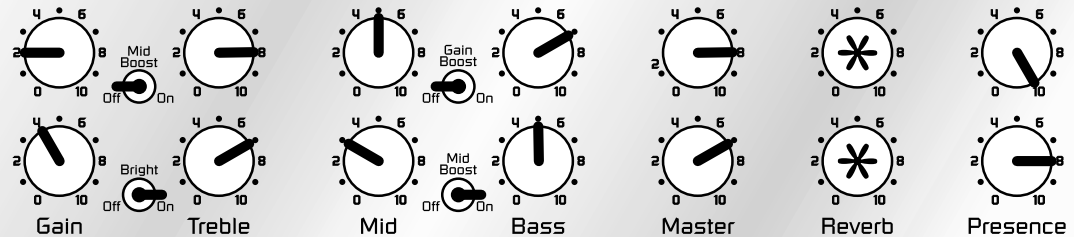

Bright 'n Crunchy:



Strong Blues:

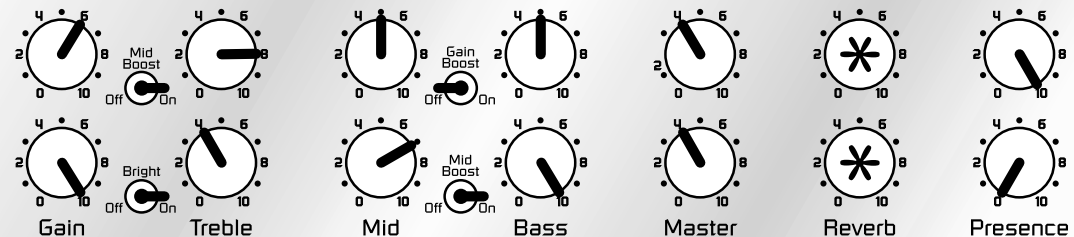

Viola:



It Goes to "12":

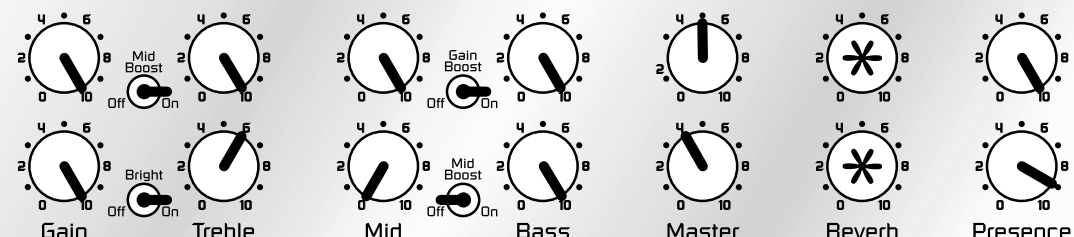

Blitzkrieg:



**Set Reverb to taste*

System Block Diagram:

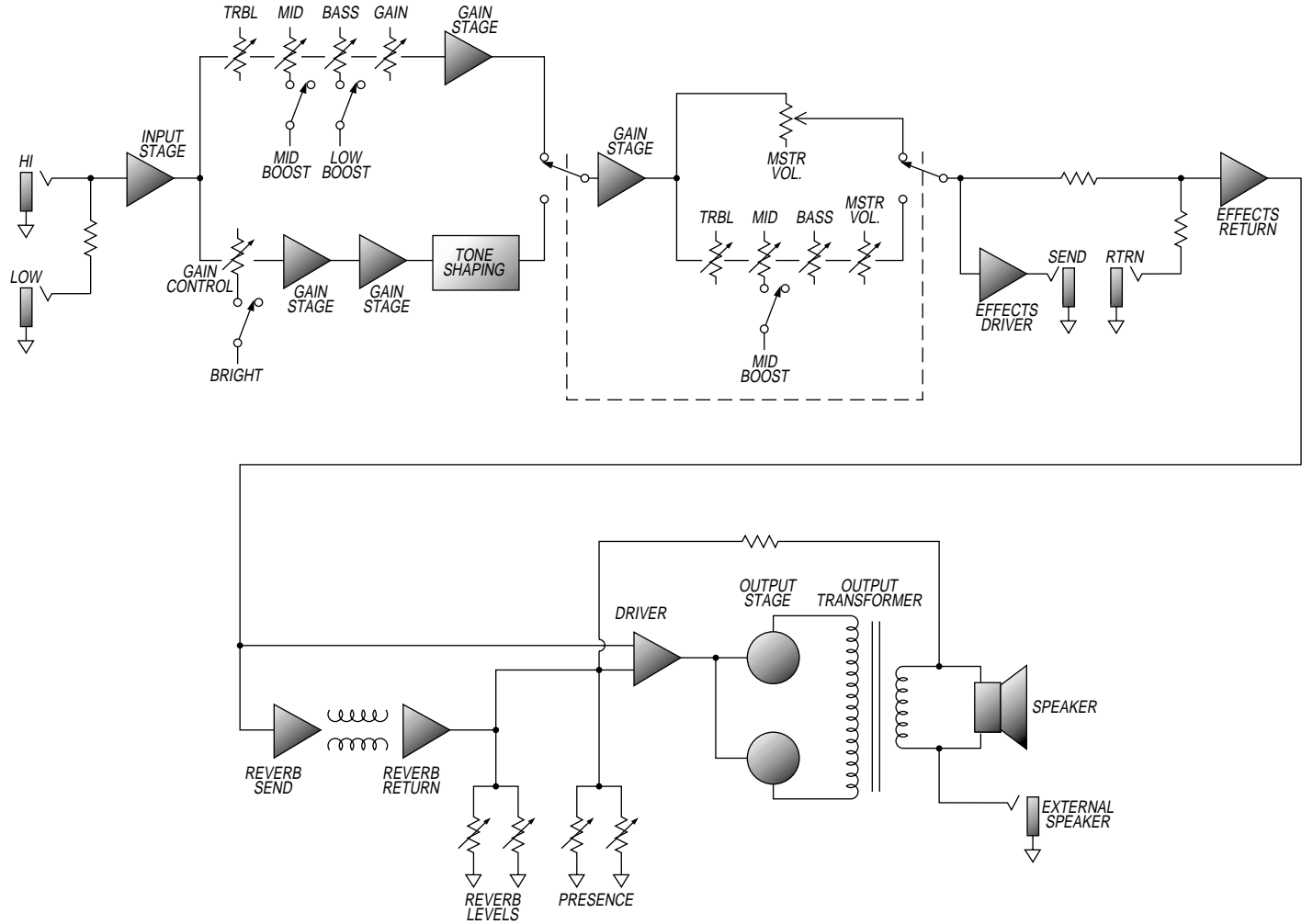



VC-6112/6210/6212 Amplifier

TECHNICAL SPECIFICATIONS:

Output Power Rating	60W RMS @ 10% THD, 16 ohm load, 120 VAC		
Input Impedance	1 M ohm		
Maximum Signal Accepted	0dB: 1.5V peak to peak; -6dB: 2.8V peak to peak		
Gain	Channel A:	68dB	
	Channel B:	100dB	
Tone Control Range	Channel A:	Treble:	16dB @ 5Hz
		Mid:	8dB @ 700Hz
		Bass:	10dB @ 50Hz
		Mid Boost:	12dB @ 800Hz
		Low Boost:	13dB @ 100Hz
	Channel B:	Treble:	16dB @ 2.5kHz
		Mid:	6dB @ 800Hz
		Bass:	22dB @ 150Hz
		Bright:	10dB @ 3kHz
		Mid Boost:	8dB @ 800Hz
	Both Channels	Presence:	4dB @ 10kHz
Effects Send	2.1V RMS @ full power output		
Speaker Complement	VC-6112:	(1) 12" Crate Vintage 16 ohm, 65W, 1.75" voice coil, 30oz magnet	
	VC-6210:	(2) 10" Crate Vintage 8 ohm, 50W, 1.75" voice coil, 30oz magnet	
	VC-6212:	(2) 12" Crate Vintage 8 ohm, 65W, 1.75" voice coil, 30oz magnet	
Tube Type	Preamp: (1) 12AU7, (4) 12AX7; Power Amp: (2) 6L6GC/EL34		
Power Requirements	120VAC, 60Hz, 300VA 100/115VAC, 50/60Hz, 300VA 230VAC, 50/60Hz, 300VA		
Size and Weight	VC-6112:	24" H x 19" W x 10" D, 48 lbs	
	VC-6210:	24" H x 19" W x 10" D, 52 lbs	
	VC-6212:	26" H x 20" W x 10" D, 55 lbs	

The VC-6112/6210/6212 is covered with a durable black Tolex® material. To keep the cabinet in top condition, wipe it clean with a damp lint-free cloth to remove dirt and road film. Never spray cleaning agents directly onto the cabinet, and stay away from abrasive cleansers which could damage the finish.

Crate continually develops new products, as well as improves existing ones. For this reason, the specifications and information in this manual are subject to change without notice.



Free Manuals Download Website

<http://myh66.com>

<http://usermanuals.us>

<http://www.somanuals.com>

<http://www.4manuals.cc>

<http://www.manual-lib.com>

<http://www.404manual.com>

<http://www.luxmanual.com>

<http://aubethermostatmanual.com>

Golf course search by state

<http://golfingnear.com>

Email search by domain

<http://emailbydomain.com>

Auto manuals search

<http://auto.somanuals.com>

TV manuals search

<http://tv.somanuals.com>