



# GLX50

**Dual Input Guitar Amplifier  
with  
Digital Signal Processing**



**User's Guide**

**TABLE OF CONTENTS:**

Introduction .....3

The Digital Signal Processor .....3

The Front Panel .....4,5

Suggested Settings .....6

System Block Diagram .....7

Technical Specifications .....back cover

 **CAUTION**   
 RISK OF ELECTRIC SHOCK  
 DO NOT OPEN

WARNING: TO REDUCE THE RISK OF FIRE OR ELECTRIC SHOCK, DO NOT EXPOSE THIS APPARATUS TO RAIN OR MOISTURE. TO REDUCE THE RISK OF ELECTRIC SHOCK, DO NOT REMOVE COVER. NO USER-SERVICEABLE PARTS INSIDE. REFER SERVICING TO QUALIFIED SERVICE PERSONNEL.

 **PRECAUCION**   
 RIESGO DE CORRIENTAZO  
 NO ABRA

ADVERTENCIA: REDUCIR EL RIESGO DE FUEGO O CHOQUE ELECTRICO, NO LE EXPONE DE ESTE APARATO A LLUVIA O HUMEDAD. PARA DISMINUIR EL RIESGO DE CORRIENTAZO, NO ABRA LA CUBIERTA. NO HAY PIEZAS ADETRON QUE EL USARIO PUEDO REPARAR DEJE TODO MANTENIMIENTO A LOS TECNICOS CALIFICADOS.

 **ATTENTION**   
 RISQUE D'ELECTROCUTION  
 NE PAS OUVRI

ATTENTION: POUR REDUIRE D'ELECTROCUTION NE PAS ENLEVER LE COUVERCLE. AUCUNE PIECE INTERNE NEST REPRABLE PAR L'UTILISATEUR. POUR TOUTE REPARATION, S'ADRESSER A UN TECHNICIEN QUALIFIE.

**IMPORTANT SAFETY INSTRUCTIONS**

- READ, FOLLOW, HEED, AND KEEP ALL INSTRUCTIONS AND WARNINGS.
- DO NOT OPERATE NEAR ANY HEAT SOURCE AND DO NOT BLOCK ANY VENTILATION OPENINGS ON THIS APPARATUS.
- DO NOT USE THIS APPARATUS NEAR SPLASHING, FALLING, SPRAYING, OR STANDING LIQUIDS.
- CLEAN ONLY WITH LINT-FREE DAMP CLOTH AND DO NOT USE CLEANING AGENTS.
- ONLY CONNECT POWER CORD TO A POLARIZED, SAFETY GROUNDED OUTLET WIRED TO CURRENT ELECTRICAL CODES AND COMPATIBLE WITH VOLTAGE, POWER, AND FREQUENCY REQUIREMENTS STATED ON THE REAR PANEL OF THE APPARATUS.
- PROTECT THE POWER CORD FROM DAMAGE DUE TO BEING WALKED ON, PINCHED, OR STRAINED.
- UNPLUG THE APPARATUS DURING LIGHTNING STORMS OR WHEN UNUSED FOR LONG PERIODS OF TIME.
- ONLY USE ATTACHMENTS, ACCESSORIES, STANDS, OR BRACKETS SPECIFIED BY THE MANUFACTURER FOR SAFE OPERATION AND TO AVOID INJURY.
- THIS APPARATUS DOES NOT OPERATE NORMALLY AND REQUIRES SERVICE WITH ANY PHYSICAL DAMAGE FROM IMPACT OR ANY EXPOSURE TO MOISTURE.
- SERVICE MUST BE PERFORMED BY QUALIFIED PERSONNEL.
- OUR AMPLIFIERS ARE CAPABLE OF PRODUCING HIGH SOUND PRESSURE LEVELS. CONTINUED EXPOSURE TO HIGH SOUND PRESSURE LEVELS CAN CAUSE PERMANENT HEARING IMPAIRMENT OR LOSS. USER CAUTION IS ADVISED AND EAR PROTECTION IS RECOMMENDED IF UNIT IS OPERATED AT HIGH VOLUME.

EXPLANATION OF GRAPHICAL SYMBOLS:

EXPLICACION DE SIMBOLOS GRAFICOS:

EXPLICATION DES SYMBOLES GRAPHIQUES:



= "DANGEROUS VOLTAGE"

= "VOLTAGE PELIGROSO"

= "DANGER HAUTE TENSION"



"IT IS NECESSARY FOR THE USER TO REFER TO THE INSTRUCTION MANUAL"

"ES NECESARIO QUE EL USUARIO SE REFIERA AL MANUAL DE INSTRUCCIONES."

"REFERREZ-VOUS AU MANUAL D'UTILISATION"

## **Congratulations!**

You are now the proud owner of the Crate GLX50 guitar amplifier. This unique amplifier allows two players to play simultaneously, making it perfect for students, band practices, and live performances. An easy to operate DSP section lets you dial in a variety of digital effects such as delay, flange, chorus and reverb. RCA inputs with a level control allow you to play along with a compact disc, a tape, or a drum machine. The active electronic tuner allows for perfect tuning and is switchable for use on either of the two channels.

Like all Crate products, your GLX50 amplifier is designed by musicians, and built using only the best components. Extensive testing confirms that this amplifier is the absolute best it can be.

In order to get the most out of your new amplifier, we strongly urge you to read the information contained in this manual before you begin playing.

And **thank you** for choosing 

## **The Digital Signal Processor:**

Crate's Digital Signal Processing offers eight exciting digital effects, accessible through the DSP Mode control. The effects are described below.

- 1 Bypass - no effect**
- 2 Delay 1 - short delay effect**
- 3 Delay 2 - long delay effect**
- 4 Flange - light flanging effect**
- 5 Chorus 1 - slow chorus effect**
- 6 Chorus 2 - fast chorus effect**
- 7 Chorus + Reverb - slow chorus with reverberation**
- 8 Reverb 1 - small room reverberation**
- 9 Reverb 2 - large hall reverberation**

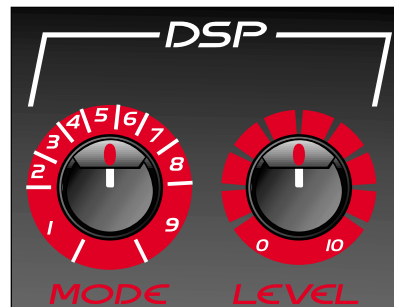

Use the Mode control to select the effect and the Level control to mix in the desired amount of each effect.

# CRATE *GLX50* Guitar Amplifier with Digital Signal Processing

## The Front Panel:

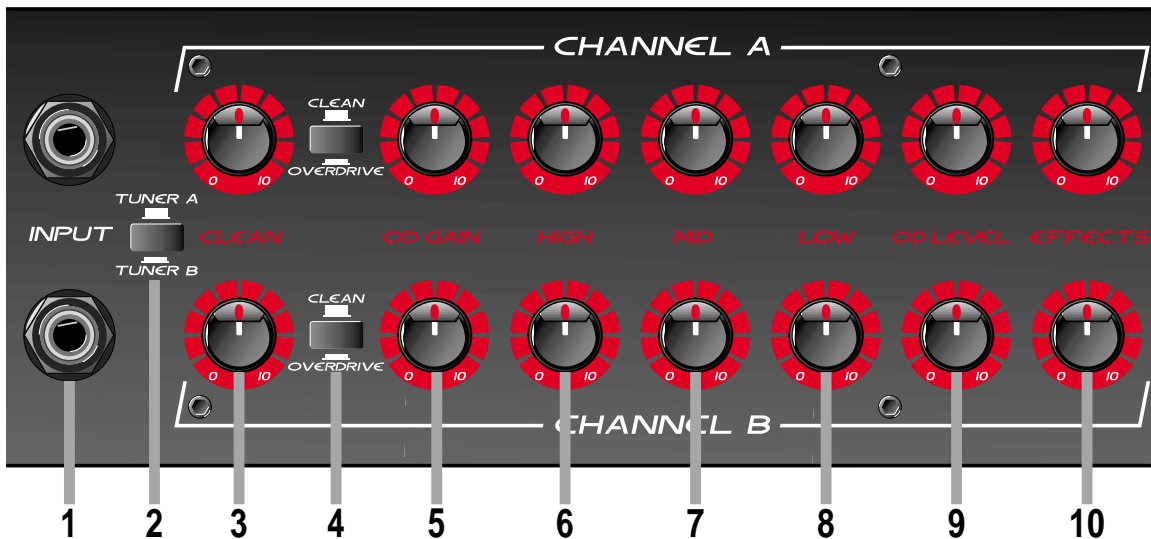

**NOTE:** Channel A and Channel B are independent of each other up to the DSP and CD inputs. The text below (#1–10) applies to both channels.

- 1. INPUT:** Use this 1/4" jack to connect your guitar to the amplifier by means of a shielded instrument cable.
- 2. TUNER A / TUNER B:** Use this switch to assign the electronic tuner (#16) to Channel A (switch in the out position) or Channel B (switch depressed).
- 3. CLEAN:** Use this control to adjust the output level of the Clean channel.
- 4. CLEAN / OVERDRIVE:** Use this switch to select the Clean channel (switch in the out position) or the Overdrive channel (switch depressed).
- 5. OD GAIN:** Use this control to adjust the Overdrive channel's input signal gain. This control works in conjunction with the OD Level control (#9) to set the amount of distortion and the output signal level of the Overdrive channel.
- 6. HIGH:** Use this control to adjust the high frequency level of the output signal. This control has a range of 27dB of boost or cut at 12kHz.
- 7. MID:** Use this control to adjust the midrange frequency level of the output signal. This control has a range of 20dB of boost or cut at 1.5kHz.
- 8. LOW:** Use this control to adjust the low frequency level of the output signal. This control has a range of 28dB of boost or cut at 40Hz.
- 9. OD LEVEL:** Use this control to adjust the Overdrive channel's output signal level. This control works in conjunction with the OD Gain control (#5).
- 10. EFFECTS:** Use this control to adjust the amount of digital effects applied to the output signal.

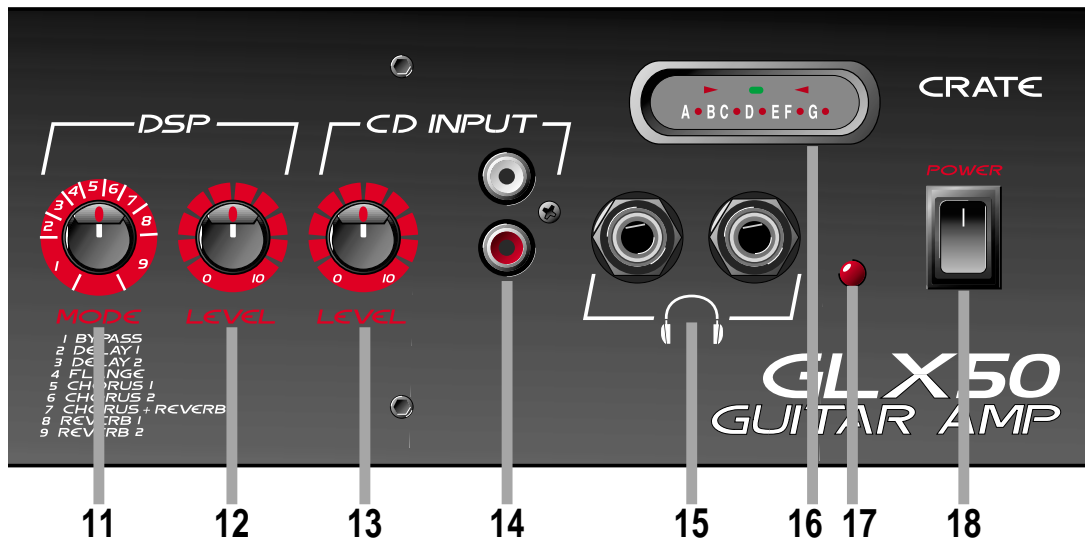

**11. DSP MODE:** Use this control to select one of the eight built-in digital effects. A listing of the effects is printed below the control knob. A brief description of these effects is shown on page 3 of this manual.

**12: DSP LEVEL:** Use this control to adjust the output level of the digital effect: in its fully counter-clockwise position the signal will be “dry” (without any effect). As you rotate the control clockwise the amount of effect increases.

**13. CD INPUT LEVEL:** Use this control to adjust the input level of the signal from the CD Input jacks (#14).

**14. CD INPUT JACKS:** Use these jacks to connect the output of a CD player, tape deck or drum machine to the amplifier. The jacks are internally summed to create a mono signal.

**15. HEADPHONES:** Use these jacks to connect one or two pairs of stereo headphones to the amplifier. Each Headphones jack monitors the signal from both Channel A and Channel B. The internal speaker is disconnected when the Headphone jacks are used.

**16. ELECTRONIC TUNER:** The electronic tuner is active whenever the amplifier is turned on, providing constant, “real-time” tuning. The bottom row of LEDs indicate which note (string) is being tuned. The top row of LEDs provides directional queues to facilitate quick and precise tuning of your instrument. The indicated note (string) is properly tuned when only the center LED is illuminated.

**17. LED:** This LED illuminates when the amplifier is on.

**18: POWER:** Use this switch to turn the amplifier on (top of the switch depressed) and off (bottom of the switch depressed).

# CRATE GLX50 Guitar Amplifier with Digital Signal Processing

## Suggested Settings:

**CRYSTAL CLEAN:**

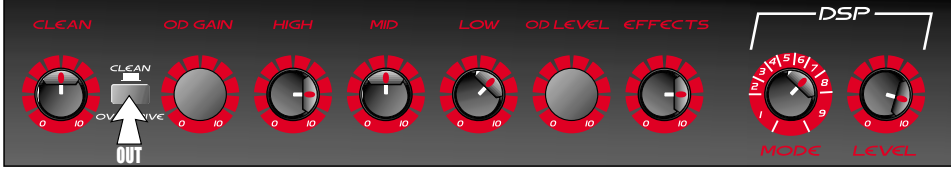

**PUNCHY CLEAN:**

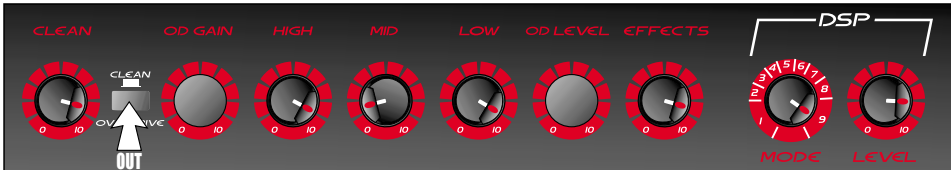

**DIRTY PUNCH:**

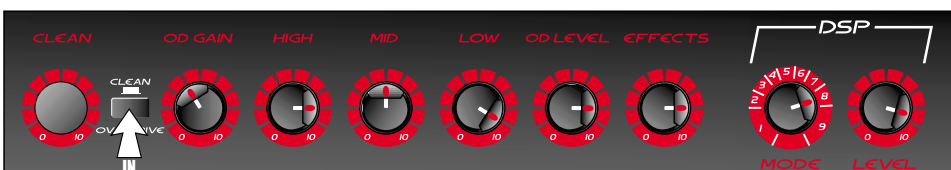

**DIRTY BLUES:**

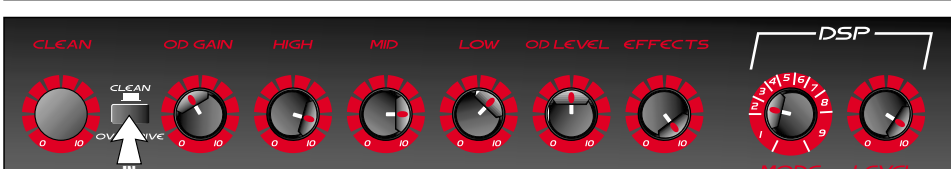

**EDGIE:**

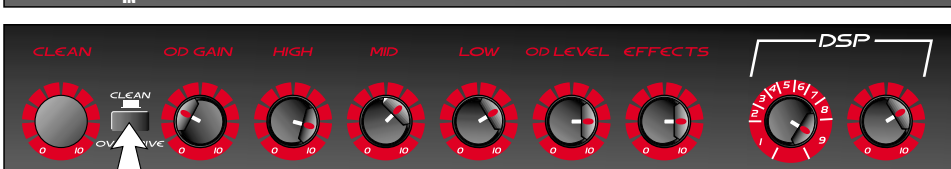

**SWEATY METAL:**

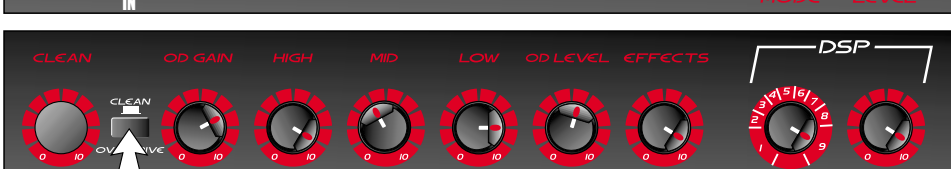

**ARENA METAL:**

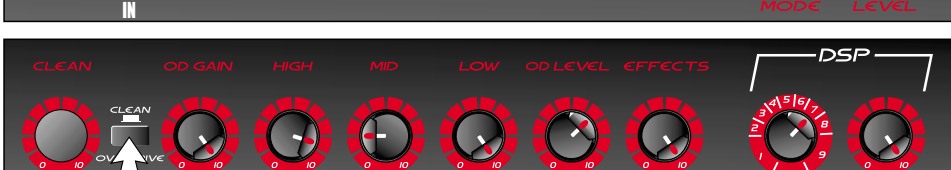

**MAMMOTH METAL:**



The image displays eight rows of suggested settings for the CRATE GLX50 guitar amplifier. Each row corresponds to a specific sound profile: CRYSTAL CLEAN, PUNCHY CLEAN, DIRTY PUNCH, DIRTY BLUES, EDGIE, SWEATY METAL, ARENA METAL, and MAMMOTH METAL. Each control panel includes a CLEAN/DIRTY selector, OD GAIN, HIGH, MID, LOW, OD LEVEL, EFFECTS, and DSP (MODE and LEVEL) knobs. The selector is set to 'CLEAN' for the first two settings and 'DIRTY' for the remaining six. The knobs are positioned to achieve the desired sound for each profile.

# CRATE GLX50 Guitar Amplifier with Digital Signal Processing

## System Block Diagram:

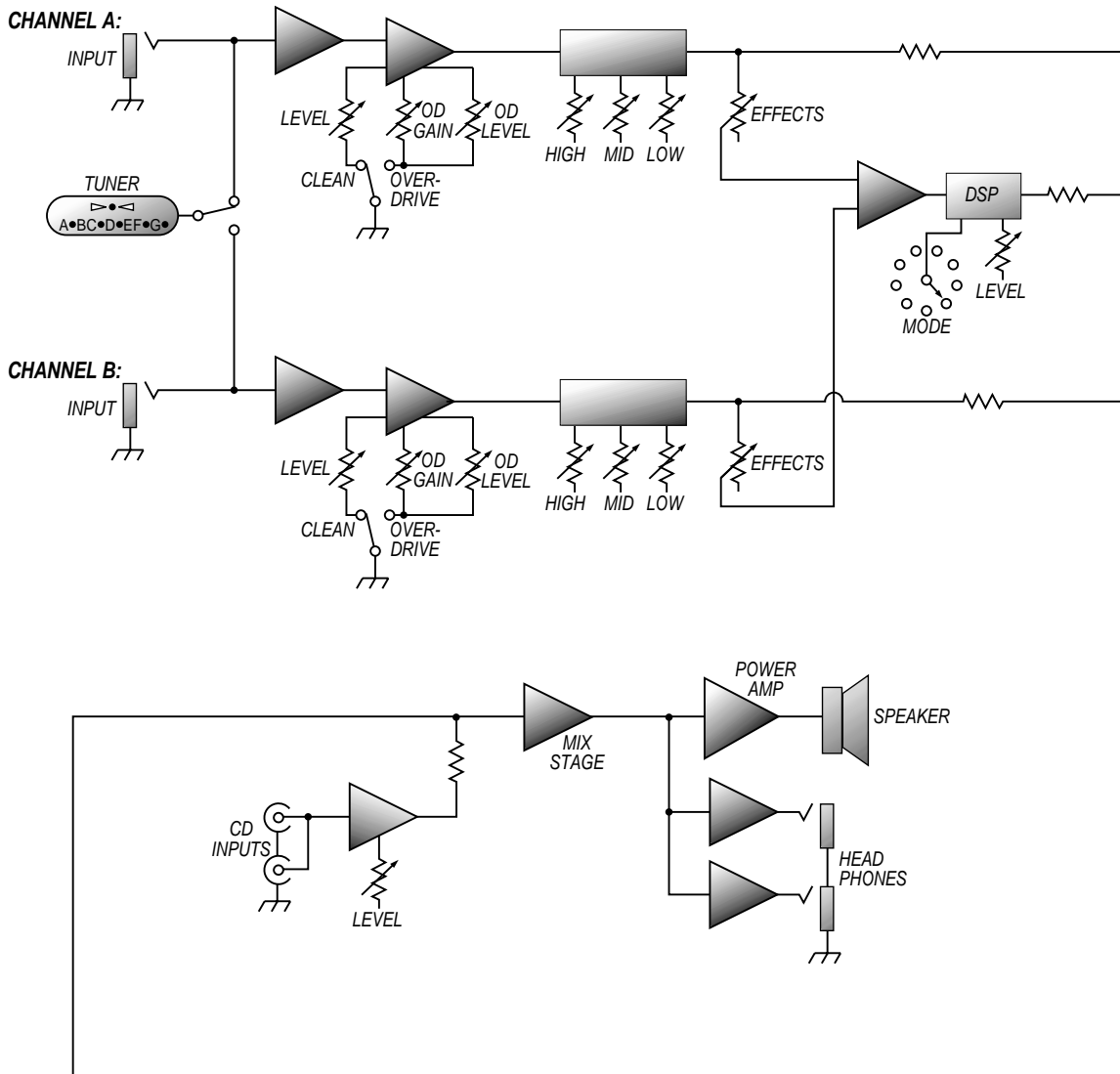

# **CRATE** *GLX50 Guitar Amplifier with Digital Signal Processing*

## **GLX50 TECHNICAL SPECIFICATIONS:**

Output Power Rating	50 watts RMS @5% THD, 4 ohm load
Maximum Input Signal Accepted	5 volts peak-to-peak
Total System Gain	Clean Channel 70dB, all controls @10 Overdrive Channel 110dB, all controls @10
Input Impedance	270k ohm
Tone Controls	Low 28dB range @ 40Hz Mid 20dB range @ 1.5kHz High 27dB range @ 12kHz
CD Inputs	Maximum signal level 7.75V rms
Headphones	Minimum impedance 32 ohms
Internal Speaker	12" Crate Custom, 4 ohms, 1.5" voice coil, 30 oz. magnet
Input Power Requirements	120 VAC, 60Hz, 75VA 100/115VAC, 50/60Hz, 75VA 230VAC, 50/60Hz, 75VA
Size and Weight	19" H x 19-3/8" W x 9-1/2" D, 28 lbs.

**The GLX50 is covered with a durable Tolex material: wipe it clean with a lint-free cloth. Never spray cleaning agents onto the cabinet. Avoid abrasive cleansers which would damage the finish.**

*Crate continually develops new products, as well as improves existing ones. For this reason, the specifications and information in this manual are subject to change without notice.*

### **Declaration Of Conformity**

#33, Effective 01-01-2001

<b>Manufacturer's Name:</b>	SLM Electronics
<b>Production Facility:</b>	11880 Borman Drive, St. Louis, MO 63146, USA
<b>Production Facility:</b>	700 Hwy 202 W, Yellville, AR 72687, USA
<b>Shipping Facility:</b>	1400 Ferguson Ave., St. Louis, MO 63133, USA
<b>Office Facility:</b>	1400 Ferguson Ave., St. Louis, MO 63133, USA
<b>Product Type:</b>	Audio Amplifier
<b>Complies with Standards:</b>	
<b>LVD:</b>	92/31/EEC, 93/68/EEC, & 73/23/EWG
<b>Safety:</b>	EN60065
<b>EMC:</b>	EN55013, EN55020, EN55022, EN61000-3-2, & EN61000-3-3

Supplementary information provided by:  
SLM Electronics - R & D Engineering  
1901 Congressional Drive, St Louis, MO 63146, USA  
Tel.: 314-569-0141, Fax: 314-569-0175



[www.crateamps.com](http://www.crateamps.com)



©2002 SLM Electronics, a division of St. Louis Music, Inc • 1400 Ferguson Avenue • St. Louis, MO 63133  
47-383-01 • 110402



## Free Manuals Download Website

<http://myh66.com>

<http://usermanuals.us>

<http://www.somanuals.com>

<http://www.4manuals.cc>

<http://www.manual-lib.com>

<http://www.404manual.com>

<http://www.luxmanual.com>

<http://aubethermostatmanual.com>

Golf course search by state

<http://golfingnear.com>

Email search by domain

<http://emailbydomain.com>

Auto manuals search

<http://auto.somanuals.com>

TV manuals search

<http://tv.somanuals.com>