

# CRATE<sup>®</sup>

## *KX-80 Keyboard Amplifier*



## **OWNER'S MANUAL**

### **Congratulations!**

You are now the proud owner of the Crate KX-100 keyboard amplifier. This versatile and great sounding amp features a 15" Crate Custom woofer and two LeSon dome tweeters housed in a ported tuned enclosure. Each of the four discrete channels has its own level and reverb/effect control while one of the channels also has separate low and high rotary EQ controls, switchable phantom power and a balanced low impedance mic input jack. The Master section features a 5-band graphic equalizer, a balanced line out jack with a level control, two effects loops and a jack for headphones.

Like all Crate products, your KX-100 is Musician Made in the U.S.A., using only the best components. Extensive testing at the hands (and ears) of skilled technicians and musicians insures you that this amplifier is the absolute best it can be.

In order to get the most out of your new amplifier, we strongly urge you to go over the information contained in this manual before you begin playing.

And ***thank you*** for choosing **CRATE<sup>®</sup>**

# CRATE® KX-100 Keyboard Amplifier

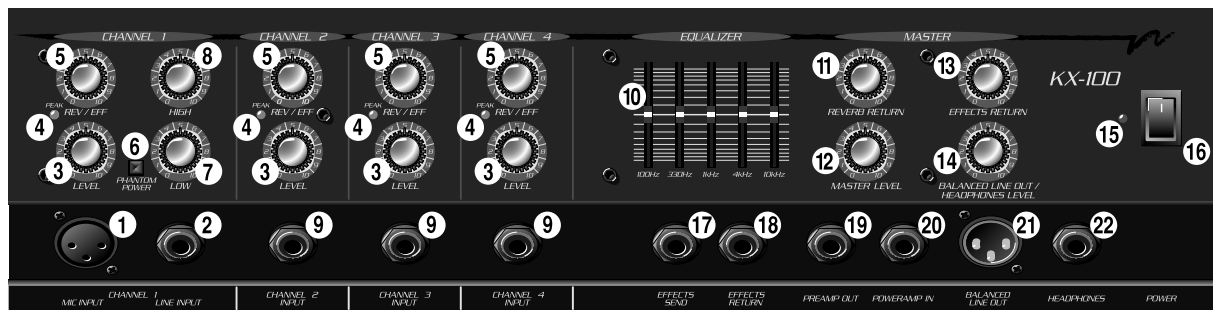

**1: Mic** input jack will accept a low impedance balanced input, such as a microphone, and may be used in conjunction with the Line Input (#2).

**2: Line** input also provides Channel 1 with a 0dB balanced input jack. It is suitable for a signal source from synthesizers.

**3: Level** controls set the gain for each channel independently.

**4: Peak Indicator LEDs** light when the corresponding input stages of the each channel are within 10dB of clipping. Adjust each Level control (#3) until a strong signal from the instrument or signal source causes the LED to flash.

**5: Reverb/Effects Send** controls are used to set the amount of reverb, as well as the amount of signal sent to the Effects Send jack (#17) for each channel.

**6: Phantom Power** applies 15 volts to the Mic input jack (#1) when this switch is pressed in.

**7: Low** control increases or decreases the bass response of channel 1.

**8: High** control increases or decreases the treble response for channel 1.

**9: Input** jacks for Channels 2, 3 and 4 accept standard 1/4" phone jacks, and are suitable for a line level source such as a signal from synthesizers.

**10: Master EQ** has five bands and enables you to shape the tonality of the KX-100 to suit room acoustics. Frequencies from 100Hz to 10kHz may be boosted by moving the sliders up or cut by moving them down.

**11: Reverb Return** acts as the reverb master level control and works with each channel's Reverb/Effects Send control (#5).

**12: Master Level** controls the total output level of the KX-100.

**13: Effects Return** control is a master volume for the Effects Loop (#17 and 18) with which you can increase or decrease the amount of effect desired. This control works with each channel's Reverb/Effects Send control (#5).

**14: Balanced Line Out/Headphones Level** adjusts the level for both the Balanced Line Out and Headphones jack and is independent of the Master volume.

**15: Power Indicator LED** will be lit when the unit is turned on.

**16: Power Switch** turns the AC power on and off.

**17: Effects Loop Send** jack, when used in conjunction with the Return jack (#18), provides a pre-EQ effects loop. The pre-EQ circuitry reduces the unwanted noise associated with most external effects devices. This output can be connected to the line input of your external effects device.

**18: Effects Loop Return** jack can be connected to the line output of your external effects device.

**19: Preamp Out** jack provides a high impedance unbalanced output for connecting the KX-100 to another amplifier or a tape recorder. Simply run a cord from this jack to the input of the other amplifier or the tape deck.

**20: Power Amp In** jack is used as a direct input to the power amp. Plugging into this jack disconnects the direct (normal) connection between the preamp and the power amp. This jack may be used with the Preamp Out jack (#19) as an effects loop.

**21: Balanced Line Out** jack is a low impedance balanced output for connection to an external amplifier or mixer with balanced inputs.

**22: Headphones** jack allows the use of stereo headphones. Connecting headphones here does not disconnect the internal speakers. For private listening, turn down the Master level control (#12).

**23: Power Cord** (rear panel, not shown): Your KX-100 is equipped with a heavy-duty grounded three-wire power cord. Be sure this cord is properly plugged into a safely wired grounded 120 volt, 60Hz AC power outlet before use. (If your KX-100 was purchased outside the United States, refer to the rear panel for power ratings.) For your safety, never attempt to defeat the ground connection on this cord.

# CRATE<sup>®</sup> KX-100 Keyboard Amplifier

## SYSTEM BLOCK DIAGRAM:

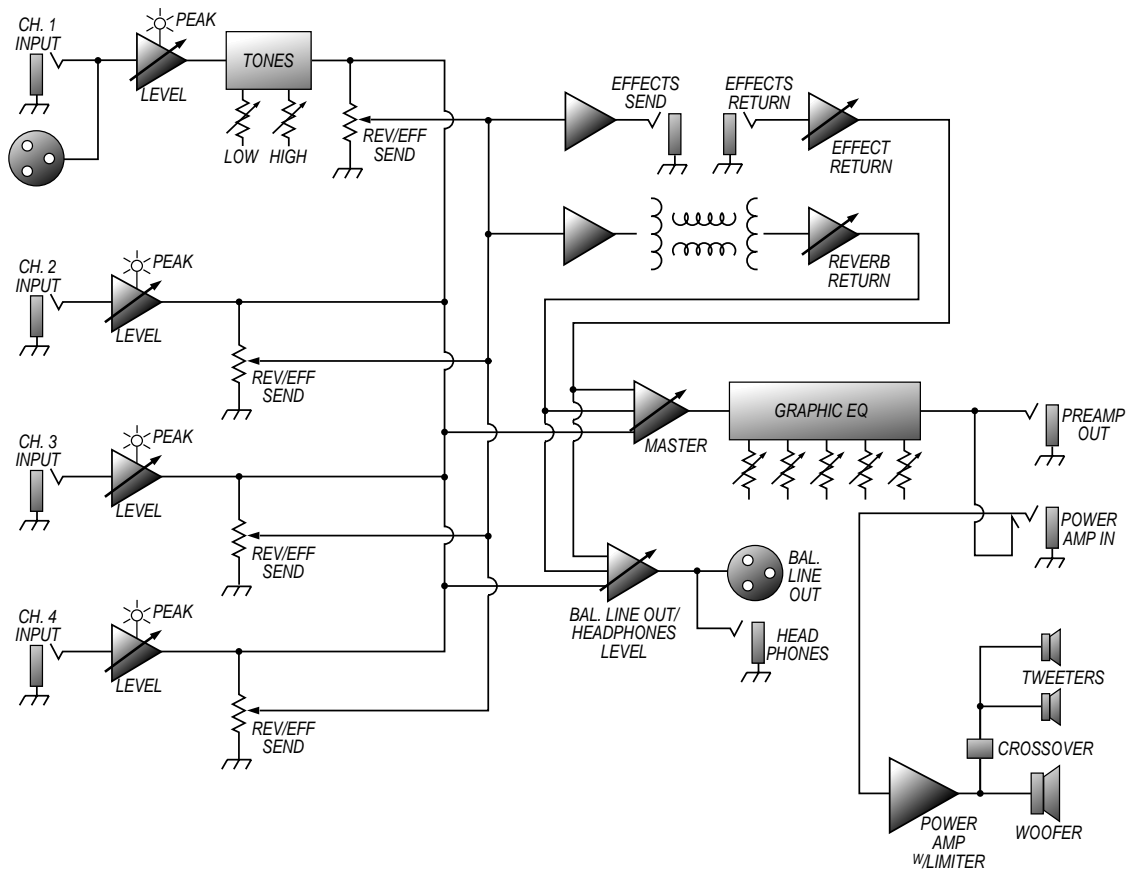

The KX-100 is covered with a durable black Tolex material: wipe it clean with a lint-free cloth. Never spray cleaning agents onto the cabinet. Avoid abrasive cleansers which would damage the finish.

El KX-100 esta cubierto con un material durable Tolex: limpielo con una toalla seca. Nunca rocíe el gabinete con sustancias limpiadoras. Evite usar materiales abrasivos con los cuales pueda danar el acabado.

Le KX-100 est couvert avec «Tolex» un recêtement noir et durable. Essayez cette matière avec une toile propre et sans charpie. Ne pulvérisez jamais les agents de nettoyage sur l'appareil. Evitez les nettoyeurs abrasifs qui peuvent endommager le «Tolex.»

**Crate continually develops new products, as well as improves existing ones. For this reason, the specifications and information in this Crate manual are subject to change without notice.**







**Crate continuamente desarrolla nuevos productos, así como también mejora los existentes. Por esta razón, las especificaciones e información incluidos en este manual están sujetos a cambios sin previo aviso.**

**Crate développe continuellement des nouveaux produits, ainsi d'améliorer ceux qui existe. Pour cette raison les spécifications et les informations dans ce manuel peuvent se changer sans préavis.**

# CRATE<sup>®</sup> KX-100 Keyboard Amplifier

## KX-100 TECHNICAL SPECIFICATIONS:

|                          |  |
|--------------------------|--|
| Maximum Signal Accepted  | Ch. 1 High Z: 10 volts peak to peak; Low Z: 15 volts peak to peak<br>Ch.'s 2, 3 and 4: 10 volts peak to peak |
| Input Power Requirements | 115 VAC, 60Hz, 110VA<br>100/110VAC, 50/60Hz, 110VA<br>230VAC, 50/60Hz, 110VA                                 |
| Nominal Input Impedance  | Ch. 1 High Z: 10k ohms; Low Z: 600 ohms<br>Ch's 2, 3 and 4: 24k ohms   |
| Gain                     | Ch. 1: High Z: 64dB; Low Z: 70dB; Ch. 2: 57dB;<br>Ch. 3: 57dB; Ch. 4: 57dB                                   |
| Output Power Rating      | 100 watts @ 5% THD w/4 ohm load  |
| Rotary EQs               | Ch. 1: ±10dB @ 50Hz, 10kHz   |
| Master EQ                | ±14dB @ 100Hz, 330Hz, 1kHz, 4kHz and 10kHz   |
| Line In/Line Out         | 1 volt RMS   |
| Limiter Range            | 20dB, maximum distortion 1%  |
| Speaker Size and Rating  | 15" Crate Custom Design w/2.5" voice coil and 56 oz. magnet<br>2 HF drivers                                  |
| Cabinet Size and Weight  | 24.5" H x 20.75" W x 15.75" D, 69 lbs.   |

|   |  |   |   |
|---|--|---|---|
|  <b>CAUTION</b><br>RISK OF ELECTRIC SHOCK<br>DO NOT OPEN     | <p>THIS EQUIPMENT HAS BEEN DESIGNED AND ENGINEERED TO PROVIDE SAFE AND RELIABLE OPERATION. IN ORDER TO PROLONG THE LIFE OF THE UNIT AND PREVENT ACCIDENTAL DAMAGES OR INJURY, PLEASE FOLLOW THESE PRECAUTIONARY GUIDELINES:</p> <p><b>CAUTION:</b> TO REDUCE THE RISK OF ELECTRIC SHOCK, DO NOT OPEN CHASSIS; DO NOT DEFEAT OR REMOVE THE GROUND PIN OF THE POWER CORD; CONNECT ONLY TO A PROPERLY GROUNDED AC POWER OUTLET.</p> <p><b>WARNING:</b> TO REDUCE THE RISK OF FIRE OR ELECTRIC SHOCK, DO NOT EXPOSE THIS EQUIPMENT TO RAIN OR MOISTURE.</p> <p><b>CAUTION:</b> NO USER-SERVICEABLE PARTS INSIDE. REFER SERVICING TO QUALIFIED SERVICE PERSONNEL.</p> <p><b>CAUTION:</b> OUR AMPLIFIERS ARE CAPABLE OF PRODUCING HIGH SOUND PRESSURE LEVELS. CONTINUED EXPOSURE TO HIGH SOUND PRESSURE LEVELS CAN CAUSE PERMANENT HEARING IMPAIRMENT OR LOSS. USER CAUTION IS ADVISED AND EAR PROTECTION IS RECOMMENDED IF UNIT IS OPERATED AT HIGH VOLUME.</p> | <p>ESTE APARATO HA SIDO DISEÑADO Y CONSTRUÍDO PARA PROVEER AÑOS DE OPERACION SEGURA Y CONFIABLE. PARA PROLONGAR LA VIDA DE ESTA UNIDAD E IMPEDIR DAÑOS ACCIDENTALES POR FAVOR SIGA ESTAS INSTRUCCIONES PREVENTIVAS:</p> <p><b>PRECAUCION:</b> PARA DISMINUIR EL RIESGO DE DESCARGAS ELECTRICAS: (1) NO ABRA LA CUBIERTA, (2) NO ES RECOMENDABLE REMOVER O DESACTIVAR LA PATA DEL POLO A TIERRA DEL CABLE DE CORRIENTE. CONECTE CORRECTAMENTE A UNA TOMA DE CORRIENTE A TIERRA.</p> <p><b>ADVERTENCIA:</b> PARA EVITAR DESCARGAS EL ECTRICAS O PELIGRO DE INCENDIO, NO DEJE ESTE APARATO EXPUESTO A LA LLUVIA O HUMEDAD.</p> <p><b>PRECAUCION:</b> NO HAY PIEZAS ADENTRO QUE EL USUARIO PUEDE REPARAR. DEJE TODO MANTENIMIENTO A LOS TÉCNICOS CALIFICADOS.</p> <p><b>PRECAUCION:</b> NUESTROS AMPLIFICADORES PUEDEN PRODUCIR NIVELES DE PRESION DE SONIDO ALTO. EXPOSICION CONTINUADA A LOS NIVELES DE PRESION DE SONIDO ALTO PUEDE CAUSA DANO PERMANENTE A SU OIDO. ES ACONSEJADO QUE USE PRECAUCIONAL USUARIO Y ES RECOMENDADO PROTECCION PARA LOS OIDOS SI LA UNIDAD ES OPERADA A VOLUMEN ALTO.</p> | <p>CET ÉQUIPEMENT AVAIT ÉTÉ INVENTÉ ET ARRANGÉ POUR POURVOIR DES ANNÉES D'USAGE SAUF ET SÛR. POUR PROLONGER LA VIE DE CET APPAREIL ET POUR EMPÊCHER LES DOMMAGES ET LES TORTS ACCIDENTELS, SUIVEZ LES INSTRUCTIONS DE PRÉCAUTION.</p> <p><b>AVERTISSEMENT:</b> POUR RÉDUIRE LES RISQUES D'ÉLECTROCUTION: (1) N'OUVREZ PAS LE CHÂSSIS, (2) NE PAS ESSAYER DE SUPPRIMER LA BROCHE CORRESPONDANT À LA TERRE.</p> <p><b>ATTENTION:</b> POUR RÉDUIRE LES RISQUES D'UN FEU OU D'ÉLECTROCUTION, N'EXPOSEZ PAS L'APPAREIL À LA PLUIE OU À LA MOI-TEUR.</p> <p><b>ATTENTION:</b> IL N'Y A PAS D'ÉLÉMENTS RÉPARABLES DANS L'APPAREIL. CONSULTER UN TECHNICIEN QUALIFIÉ POUR LES RÉPARATIONS.</p> <p><b>ATTENTION:</b> NOS AMPLIFICATEURS SONT CAPABLES DE LA PRODUCTION DES NIVEAUX DE SON D'UNE HAUTE PRESSION. L'EXPOSITION CONTINUE AUX CES NIVEAUX PEUT CAUSER LA SURDITÉ PERMANENTE. LA PRUDENCE EST ADVISÉ À UTILISATEUR ET LA PROTECTION DES OREILLES EST RECOMMANDÉ SI L'APPAREIL EST UTILISÉ À UN HAUT NIVEAU DE VOLUME.</p> |
|  <b>PRECAUCION</b><br>RIESGO DE CORRIENTAZO<br>NO ABRA       |  |   |   |
|  <b>ATTENTION</b><br>RISQUE D'ELECTROCUTION<br>NE PAS OUVRIR |  |   |   |
|  <b>VORSICHT</b><br>ELEKTRISCHE SCHLAGEFAHR<br>NICHT OFFENEN |  |   |   |
| EXPLANATION OF GRAPHICAL SYMBOLS:<br>EXPLICACION DE SIMBOLOS GRAFICOS:<br>EXPLICATION DES SYMBOLES GRAPHIQUES:                                  |  = "DANGEROUS VOLTAGE"<br>"VOLTAJE PELIGROSO"<br>"DANGER HAUTE TENSION"<br>"GEFAHLICHE SPANNUNG"  |  = "IT IS NECESSARY FOR THE USER TO REFER TO THE INSTRUCTION MANUAL."<br>"ES NECESARIO QUE EL USUARIO SE REFIERA AL MANUAL DE INSTRUCCIONES."<br>"REFERREZ-VOUS AU MANUAL D'UTILISATION"<br>"UNBEDINGT IN DER BEDIENUNGSANLEITUNG NACHSCHLAGEN"  |   |

**CRATE<sup>®</sup>**  
www.crateamps.com



©1997 SLM ELECTRONICS, A DIVISION OF ST. LOUIS MUSIC, 1400 FERGUSON, ST. LOUIS, MO. 63133  
P/N 47-444-02 • 06/97

## Free Manuals Download Website

<http://myh66.com>

<http://usermanuals.us>

<http://www.somanuals.com>

<http://www.4manuals.cc>

<http://www.manual-lib.com>

<http://www.404manual.com>

<http://www.luxmanual.com>

<http://aubethermostatmanual.com>

Golf course search by state

<http://golfingnear.com>

Email search by domain

<http://emailbydomain.com>

Auto manuals search

<http://auto.somanuals.com>

TV manuals search

<http://tv.somanuals.com>