

User's Guide

for the

CRATE PRO AUDIO

SPA-1400/1400C

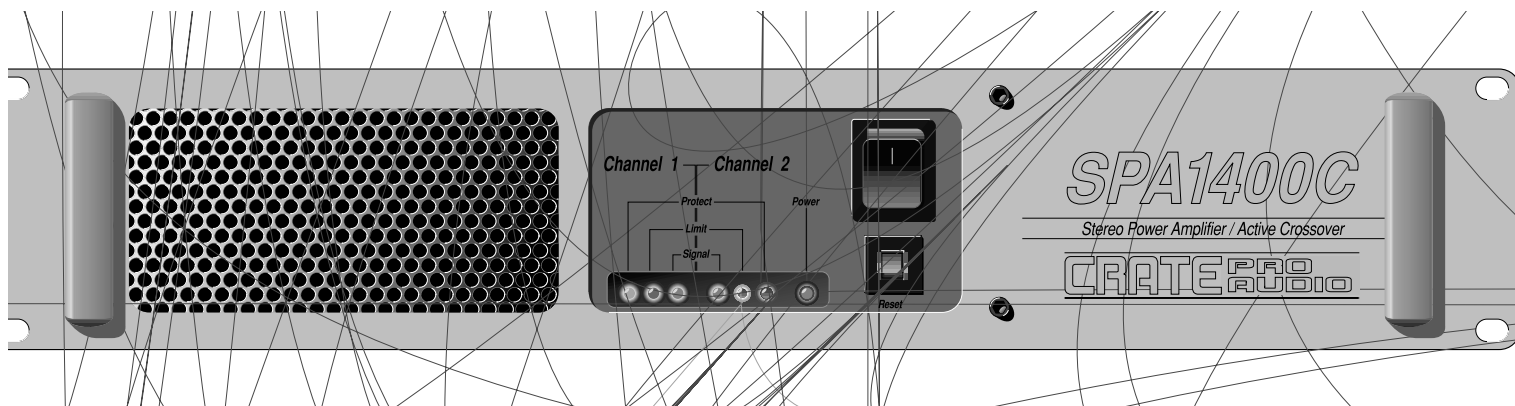

Rack Mount







Power Amplifier

In order to achieve maximum performance from your new Crate Pro Audio SPA Series Power Amp we recommend that you read this user's guide prior to its use.

CRATE PRO AUDIO

Contents:

- Introduction3
- Features3
- Front Panel Information4
- Rear Panel Information5,6
- Speaker Impedances And Power Ratings7
- Installation and Operation
 - Stereo Operation8
 - Main / Monitor Combination9
 - Parallel Mono Operation10
 - Bridged Mono Operation11
 - Patching Two Bridged Mono Systems12
 - Connecting Multiple Amplifiers (SPA-1400C only)13
- Biamping
 - SPA-1400: One Amp, Single Cabinet14
 - SPA-1400: One Amp, Separate Cabinets15
 - SPA-1400C: One Stereo Amp16
 - SPA-1400C: With Multiple Amps17
 - SPA-1400C: Two Mono Bridged Amps18
- Triamping
 - SPA-140019
 - SPA-1400C20
- System Block Diagrams21
- Mode Block Diagrams22
- Installation Notes / Mounting Dimensions23
- Technical Specificationsback cover

 <p>CAUTION RISK OF ELECTRIC SHOCK DO NOT OPEN</p>	 <p>PRECAUCION RIESGO DE CORRIENTAZO NO ABRA</p>	 <p>ATTENTION RISQUE D'ELECTROCUTION NE PAS OUVRIR</p>	 <p>VORSICHT ELEKTRISCHE SCHLAGEGFAHR NICHT OFFENEN</p>																							
<p>CAUTION: TO REDUCE THE RISK OF ELECTRIC SHOCK, DO NOT REMOVE COVER. NO USER-SERVICEABLE PARTS INSIDE. REFER SERVICING TO QUALIFIED SERVICE PERSONNEL.</p>	<p>PRECAUCION PARA DISMINUIR EL RIESGO DE CORRIENTAZO NO ABRA LA CUBIERTA NO HAY PIEZAS ADENTRO QUE EL USUARIO PUEDE REPARAR DEJE TODO MANTENIMIENTO A LOS TECNICOS CALIFICADOS</p>	<p>ATTENTION: POUR REDUIRE D'ELECTROCUTION NE PAS ENLEVER LE COUVERCLE. AUCUNE PIECE INTERNE N'EST REPARABLE PAR L'UTILISATEUR. POUR TOUTE REPARATION, S'ADRESSER A UN TECHNICIEN QUALIFIE.</p>	<p>VORSICHT: ZUR MNIMIERUNG ELEKTRISCHER SCHLAGEGFAHR NICHT DEN DECKEL ABENHMEN. INTERNE TEILE KONNEN NICHT VOM BENUTZER GEWARTET WERDEN. DIE WARTUNG IS QUALIFIZIERTEM WARTUNGSPERSONAL ZU UBERLASSEN.</p>																							
<p>THIS EQUIPMENT HAS BEEN DESIGNED AND ENGINEERED TO PROVIDE SAFE AND RELIABLE OPERATION. IN ORDER TO PROLONG THE LIFE OF THE UNIT AND PREVENT ACCIDENTAL DAMAGES OR INJURY, PLEASE FOLLOW THESE PRECAUTIONARY GUIDELINES:</p>	<p>CAUTION: TO REDUCE THE RISK OF ELECTRIC SHOCK, DO NOT OPEN CHASSIS; DO NOT DEFEAT OR REMOVE THE GROUND PIN OF THE POWER CORD; CONNECT ONLY TO A PROPERLY GROUNDED AC POWER OUTLET.</p>	<p>WARNING: TO REDUCE THE RISK OF FIRE OR ELECTRIC SHOCK, DO NOT EXPOSE THIS EQUIPMENT TO RAIN OR MOISTURE.</p> <p>CAUTION: NO USER-SERVICEABLE PARTS INSIDE. REFER SERVICING TO QUALIFIED SERVICE PERSONNEL.</p>	<p>CAUTION: OUR AMPLIFIERS ARE CAPABLE OF PRODUCING HIGH SOUND PRESSURE LEVELS. CONTINUED EXPOSURE TO HIGH SOUND PRESSURE LEVELS CAN CAUSE PERMANENT HEARING IMPAIRMENT OR LOSS. USER CAUTION IS ADVISED AND EAR PROTECTION IS RECOMMENDED IF UNIT IS OPERATED AT HIGH VOLUME.</p>																							
<p>ESTE APARATO HA SIDO DISENADO Y CONSTRUIDO PARA PROVEER ANOS DE OPERACION SEGURA Y CONFIABLE. PARA PROLONGAR LA VIDA DE ESTA UNIDAD E IMPEDIR DANOS ACCIDENTALES POR FAVOR SIGA ESTAS INSTRUCCIONES PREVENTIVAS:</p>	<p>PRECAUCION: PARA DISMINUIR EL RIESGO DE DESCARGAS ELECTRICAS: (1) NO ABRA LA CUBIERTA, (2) NO ES RECOMENDABLE REMOVER O DESACTIVAR LA PATA DEL POLO A TIERRA DEL CABLE DE CORRIENTE, CONECTE CORRECTAMENTE A UNA TOMA DE CORRIENTE A TIERRA.</p>	<p>ADVERTENCIA: PARA EVITAR DESCARGAS ELECTRICAS O PELIGRO DE INCENDIO, NO DEJE ESTE APARATO EXPUESTO A LA LLUVIA O HUMEDAD.</p> <p>PRECAUCION: NO HAY PIEZAS ADENTRO QUE EL USUARIO PUEDE REPARAR. DEJE TODO MANTENIMIENTO A LOS TECNICOS CALIFICADOS.</p>	<p>PRECAUCION: NUESTROS AMPLIFICADORES PUEDEN PRODUCIR NIVELES DE PRESION DE SONIDO ALTO. EXPOSICION CONTINUADA A LOS NIVELES DE PRESION DE SONIDO ALTO PUEDE CAUSAR DANO PERMANENTE A SU OIDO. ES ACONSEJADO QUE USE PRECAUCION AL USUARIO Y ES RECOMENDADO PROTECCION PARA LOS OIDOS SI LA UNIDAD ES OPERADA A VOLUMEN ALTO.</p>																							
<p>THE CHART BELOW SHOWS THE U.S. GOVERNMENT'S OCCUPATIONAL SAFETY AND HEALTH ADMINISTRATION (OSHA) REGULATIONS WHICH WERE IN EFFECT AT THE TIME OF THIS PUBLICATION FOR PERMISSIBLE NOISE EXPOSURE, PER 29CFR1910.95, TABLE G-16:</p>																										
<table border="1" style="width: 100%; border-collapse: collapse;"> <thead> <tr> <th>SOUND LEVEL DBA, SLOW RESPONSE</th> <th>DURATION PER DAY IN HOURS</th> </tr> </thead> <tbody> <tr><td>90</td><td>8</td></tr> <tr><td>92</td><td>6</td></tr> <tr><td>95</td><td>4</td></tr> </tbody> </table>	SOUND LEVEL DBA, SLOW RESPONSE	DURATION PER DAY IN HOURS	90	8	92	6	95	4	<table border="1" style="width: 100%; border-collapse: collapse;"> <thead> <tr> <th>SOUND LEVEL DBA, SLOW RESPONSE</th> <th>DURATION PER DAY IN HOURS</th> </tr> </thead> <tbody> <tr><td>97</td><td>3</td></tr> <tr><td>100</td><td>2</td></tr> <tr><td>102</td><td>1 - 1 1/2</td></tr> </tbody> </table>	SOUND LEVEL DBA, SLOW RESPONSE	DURATION PER DAY IN HOURS	97	3	100	2	102	1 - 1 1/2	<table border="1" style="width: 100%; border-collapse: collapse;"> <thead> <tr> <th>SOUND LEVEL DBA, SLOW RESPONSE</th> <th>DURATION PER DAY IN HOURS</th> </tr> </thead> <tbody> <tr><td>105</td><td>1</td></tr> <tr><td>110</td><td>1/2</td></tr> <tr><td>115</td><td>1/4 or less</td></tr> </tbody> </table>	SOUND LEVEL DBA, SLOW RESPONSE	DURATION PER DAY IN HOURS	105	1	110	1/2	115	1/4 or less
SOUND LEVEL DBA, SLOW RESPONSE	DURATION PER DAY IN HOURS																									
90	8																									
92	6																									
95	4																									
SOUND LEVEL DBA, SLOW RESPONSE	DURATION PER DAY IN HOURS																									
97	3																									
100	2																									
102	1 - 1 1/2																									
SOUND LEVEL DBA, SLOW RESPONSE	DURATION PER DAY IN HOURS																									
105	1																									
110	1/2																									
115	1/4 or less																									
<p>ACCORDING TO OSHA, ANY EXPOSURE IN EXCESS TO THESE AMOUNTS LISTED ABOVE COULD RESULT IN SOME HEARING LOSS.</p>																										
<p>EXPLANATION OF GRAPHICAL SYMBOLS: EXPLICACION DE SIMBOLOS GRAFICOS:</p>	 = "DANGEROUS VOLTAGE" "VOLTAJE PELIGROSO" "DANGER HAUTE TENSION" "GEFAHRICHE SPANNUNG"	 = "IT IS NECESSARY FOR THE USER TO REFER TO THE INSTRUCTION MANUAL" "ES NECESARIO QUE EL USUARIO SE REFIERA AL MANUAL DE INSTRUCCIONES." "REFERREZ-VOUS AU MANUAL D'UTILISATION" "UNBEDINGT IN DER BETRIEBUNGSANLEITUNG NACHSCHLAGEN"																								

CRATE PRO AUDIO SPA-1400/1400C Rack Mount Power Amplifier

Introduction:

Congratulations. You have selected one of the finest pieces of sound reinforcement equipment available, the Crate Pro Audio SPA-1400/1400C Rack Mounted Amplifier. Our many years of experience in high-performance audio equipment, combined with our extensive research and development procedures, have enabled us to produce an amplifier which provides the highest quality and reliability possible.

Like all Crate products, your SPA-1400/1400C amplifier was designed and manufactured using only the finest components and materials. Each amplifier design must satisfy our team of highly-trained technicians and musicians before it is approved, and each individual amplifier must pass a barrage of bench tests before it leaves the factory. We insist upon this extreme level of quality control to insure us that each amplifier produced will provide its owner with years of trouble-free, ear-pleasing performance.

Your new SPA-1400/1400C is a flexible part of any sound system – simple to connect and easy to operate – if you first know how to incorporate it into your application. Several configurations are covered in this manual, along with important information regarding impedance ratings and output power. **In order to get the best performance and highest level of quality and reliability from your new amplifier, please read this owner's manual before operating the unit.**

Features:

The Crate SPA-1400/1400C is a ruggedly constructed high quality power amplifier designed to give you continuous performance with professional results. The amplifier mounts into a standard 19" rack, requiring only two rack spaces (3-1/2 inches, vertically). Two automatic variable-speed internal cooling fans use the sides, rear and the front of the amplifier - not the top and bottom - for its air intake and exhaust, allowing you to stack multiple amplifiers closer together in a rack mount situation. Additional rack support holes have been provided along the rear of the amplifier for the most secure installation possible. (Use of these additional supports is strongly recommended – refer to page 23 for more information.)

The SPA-1400/1400C produce up to 660 watts of power per channel @ 2 ohms, 425 watts per channel @ 4 ohms stereo mode or 260 watts per channel @ 8 ohms (stereo mode); 1320 watts @ 4 ohms, 850 watts @ 8 ohms or 520 watts at 16 ohms (bridged mono mode). Several "professional" features have been built into the amplifier, such as 1/4" phone and XLR input jacks with electronically balanced Low or Medium impedance operation. Built-in automatic limiting circuitry with LED indicators constantly monitors the output of each channel and provides protection against clipping, thus preventing the generation of speaker-damaging square waves. A built-in protection circuit guards the amplifier against damages from overloads, short circuits, or overheating. In addition, each channel features a Signal LED to assist in hookup and troubleshooting, and a Fault LED which indicates when the internal protection circuitry is activated. Output connections can be made by either high current five way binding post sets or professional-quality Speakon® jacks.

The SPA-1400/1400C also features a Parallel Mono switch which internally parallels the inputs of both channels. A signal fed into channel 1 can be split to both channels internally (no additional cables required), with each channel's Level controls operating independently. This is especially valuable when two different output levels are needed, such as one for main and another for side fill, or for different paging zones. Using this feature also allows a large number of speakers (up to eight 8 ohm cabinets) from one amplifier, with only one input signal and no cables for channel patching.

Unique to the SPA-1400C are dual tuneable 12dB/octave low-cut filters, an active two-way 24dB/octave electronic crossover and switchable XLR Thru / Crossover Out jacks. The low-cut filters allow elimination of frequencies below the range of the speakers, which in turn eliminates cone flutter, wasted power and thermal stress on both speaker and amplifier. The electronic crossovers allow optimum tuning of the system to your low and high frequency speakers. The switchable XLR Thru / Crossover Out jacks allow (A) direct connection to additional external amplifiers (XLR Thru mode – XLR jacks in parallel with the XLR and 1/4" input jacks), or (B) sending the low and/or high frequency signals for biamping (Crossover Out mode). More information is contained in the Front Panel and Installation sections of this manual.

CRATE PA80 SPA-1400/1400C Rack Mount Power Amplifier

Front Panel Information:

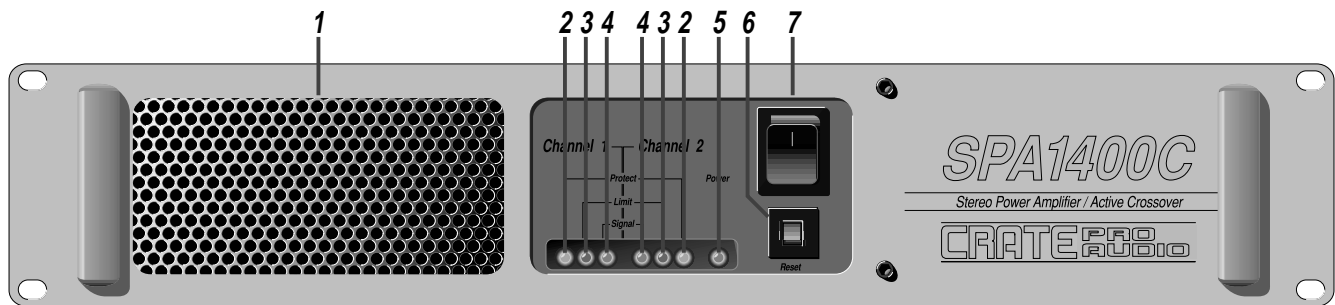

1: COOLING FAN EXHAUST VENT: The SPA-1400/1400C employs a pair of variable-speed internal cooling fans to draw air through the unit and keep it running cool even under extreme operating conditions. The air is drawn in through the unit's side and rear intake vents and is forced out through the front panel exhaust vent. This method of cooling draws air out from the interior of the rack and provides more efficient cooling than methods which bring air in from the front and exhaust it through the back. Keep these vents clear and free from obstruction at all times to insure proper cooling.

2: PROTECT INDICATOR LEDs: These LEDs will illuminate whenever the internal protection relay for the channel is activated. The protection relay is activated for a short period upon initial turn-on and at turn-off to prevent transient "spikes" from being reproduced through your speakers. A protect condition is also indicated if the unit gets too hot, or if DC voltages are present at the output. During thermal protection, both channels are shut down until the temperature returns to a safe operating level. In the event of DC voltage on the output, only the affected channel will be disconnected. The circuitry associated with the LED indicators provides valuable protection for both the amplifier and your speakers.

3: LIMIT INDICATOR LEDs: The SPA-1400/1400C employs an internal "Automatic" limit circuit to prevent the amplifier from clipping. The Limit LEDs will illuminate whenever the input signal attempts to overdrive the amplifier's output section, indicating that the Limiter has been called upon to prevent clipping. (Not only does clipping produce harsh sounding distortion, it is also capable of damaging speaker components – particularly high frequency drivers.) Periodic flashing of the Limit LEDs indicates operation at or near full output and is no cause for alarm. Steady illumination of one or both LEDs indicates constant operation of the Limiter, with the possibility that the input

signal should be reduced by means of the Level control (#15, rear panel). The Limiter within the amplifier is fully automatic, insuring you complete protection against clipping at all times.

4: SIGNAL INDICATOR LEDs: These LEDs will illuminate when signal is detected at the amplifier's output terminals, providing accurate visual confirmation of signal presence, which is helpful in hookup and troubleshooting. The output signal must be at least 5% of the amplifier's full rated output to make the LEDs glow.

5: POWER INDICATOR LED: This LED will illuminate when AC power is applied by means of the **POWER SWITCH** (#7). If the LED fails to illuminate, check the AC outlet or the **RESET SWITCH** (#6).

6: RESET SWITCH: The SPA-1400/1400C employs an AC line circuit breaker to help protect against damages due to excessive current demands. If the amplifier does not function, check the circuit breaker. If it has opened, the button will be protruding and showing a contrasting color. You may reset it by pressing the button in until it latches. The circuit breaker must cool down for a short time before the button will latch. If the circuit breaker opens repeatedly with no signal input, have the amplifier checked by a qualified service person.

7: POWER SWITCH: This switch turns the amplifier on in the up position ("I" pressed in) and off in the down position. When AC power is applied to the amplifier, the **POWER INDICATOR LED** (#5) will illuminate.

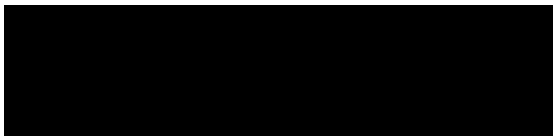
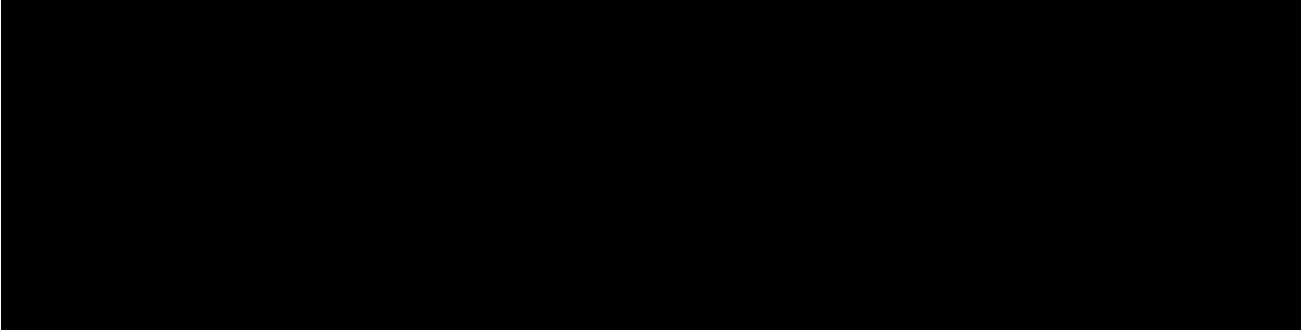

Rear Panel Information – “Export”:

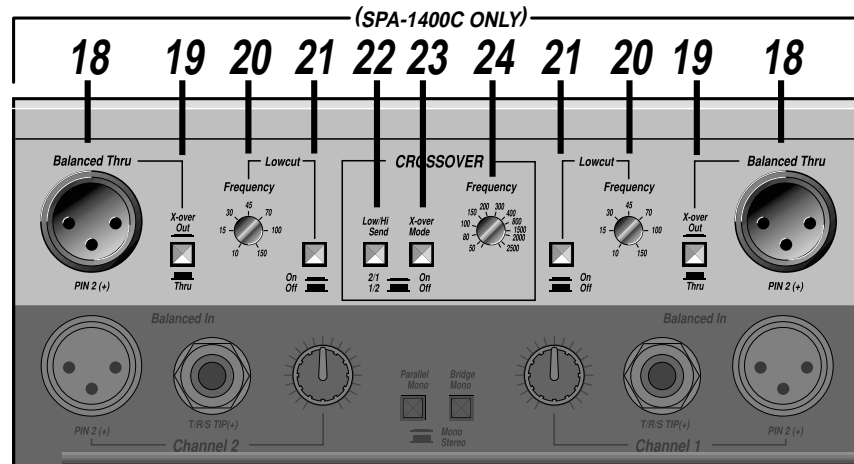

18: BALANCED THRU/X-OVER OUT JACKS: These male XLR jacks are independently switchable and have two uses:

(1) **Balanced Thru:** For driving additional amplifiers with the same input signal, set the **X-OVER OUT/THRU** switch (#19) to the THRU position (switch out). This places its corresponding Balanced Thru/X-Over Out jack in parallel to the same channel's XLR and 1/4" input jacks. Connect a balanced cable with XLR plugs from the Balanced Thru/X-Over Out jack of the first amplifier to the input jack of the next. Wire the cable as follows: pin 2 = "+", pin 3 = "-".

(2) **Crossover Out:** To send the crossover output signal to an external amplifier, set the **X-OVER OUT/THRU** switch (#19) to the X-OVER OUT position (switch pressed in). Connect a balanced cable with XLR plugs from the Balanced Thru/X-Over Out jack of the first amplifier to the input of the other amplifier. Whether the jack carries the low or high frequency signal is dependent upon the setting of the **CROSSOVER HI/LOW SEND** switches (#22).

19: X-OVER OUT/THRU SWITCH: These switches set the operating mode for the Balanced Thru/X-Over Out jacks (#18). Set the switch "out" (flush with the panel) for Balanced Thru operation; press the switch in (recessed into the chassis) for Crossover Out operation.

20. LOW CUT FREQUENCY CONTROLS: These controls adjust the cut-off frequency of the low cut filters (when active – see #21). Use a small flatblade screwdriver to adjust the controls. The cut-off range is from 10Hz (full counterclockwise) to 150Hz (full clockwise).

21: LOW CUT SWITCHES: These pushbutton switches activate the low cut filters when pressed in. The cut-off frequency is determined by the setting of the **LOW CUT FREQUENCY** control (#20).

22: CROSSOVER LOW/HI SEND SWITCH: This pushbutton switch determines where the low and high crossover signals are sent:

Switch IN: Low to channel 2, High to channel 1 (2/1)

Switch OUT: Low to channel 1, High to channel 2 (1/2)

23: CROSSOVER MODE SWITCH: This switch determines whether the amplifier channels are driven from the crossover outputs or from the normal input signal. With the switch in the "off" position (pressed out), the amp is driven normally. With the switch in the "on" position (pressed in), the channel 1 input signal is split into a low frequency and a high frequency signal. One signal is sent to the amp's channel 1 outputs, the other to its channel 2 outputs, depending on the setting of the **LOW/HIGH SEND** switch (#22). (See the additional information below.)

24: CROSSOVER FREQUENCY CONTROL: This control adjusts the crossover frequency (when active – see #23). Use the tip of a small flatblade screwdriver to adjust the control, from 45Hz (full counterclockwise) to 2500Hz (full clockwise).

More About the Crossover:

The electronic crossover is ideal for use with subwoofers and may also be used to crossover from low to mid, mid to high or low to high on biampable speakers.

The input signal to the crossover is taken from channel 1, after the **LOW CUT** filter. The crossover output may be used internally, externally, or both, by use of the **LOW/HI SEND** switch (#22), the **BALANCED THRU/X-OVER OUT** jacks (#18), and the **X-OVER OUT/THRU** switches (#19). A signal can be sent to a completely separate amplifier if desired (see page 17).

Note: Regardless of the setting of the **CROSSOVER MODE** switch (#23), you can still take a line level crossover output signal from the **BALANCED THRU/X-OVER OUT** jacks (#18). The **X-OVER OUT/THRU** switch (#19) must be set to "X-Over Out" (pressed in), and the **LOW/HI SEND** switch (#22) will determine where to tap the low and high frequency signals (ie, lows to channel 2, highs to channel 1 when the switch is pressed in). The crossover is always active, even if it is not selected "on" for internal use.

CRATE PRO SPA-1400/1400C Rack Mount Power Amplifier

Speaker Impedances And Power Ratings:

When connecting speaker cabinets, you must observe proper load impedances. Whenever connecting multiple cabinets to an amplifier, the total load impedance must be calculated to insure proper performance from the amplifier. The table which follows shows the total load impedances of many common parallel speaker combinations:

		SYSTEM ONE																								
		SINGLE SPEAKER			TWO SPEAKERS IN PARALLEL																					
		4Ω	8Ω	16Ω	4:4Ω	4:8Ω	4:16Ω	8:8Ω	8:16Ω	16:16Ω																
SYSTEM TWO	ONE SPKR	4Ω	2Ω	2.7Ω	3.2Ω	1.3Ω	1.6Ω	1.8Ω	2Ω	2.3Ω	2.7Ω	2.7Ω	3.2Ω	3.2Ω	4Ω	5.3Ω										
	TWO IN PARALLEL	8Ω	2.7Ω	4Ω	5.3Ω	1.6Ω	2Ω	2.3Ω	2.7Ω	3.2Ω	3.2Ω	4Ω	5.3Ω	4:4Ω	1.3Ω	1.6Ω	1.8Ω	1Ω	1.1Ω	1.2Ω	1.3Ω	1.5Ω	1.6Ω	1.8Ω	2Ω	2.3Ω
	4:8Ω	1.6Ω	2Ω	2.3Ω	1.1Ω	1.3Ω	1.5Ω	1.6Ω	1.8Ω	2Ω	2.3Ω	2.7Ω	8:8Ω	2Ω	2.7Ω	3.2Ω	1.3Ω	1.6Ω	1.8Ω	2Ω	2.3Ω	2.7Ω	3.2Ω	3.2Ω	4Ω	5.3Ω
	4:16Ω	1.8Ω	2.3Ω	2.7Ω	1.2Ω	1.5Ω	1.6Ω	1.8Ω	2Ω	2.3Ω	2.7Ω	3.2Ω	8:16Ω	2.3Ω	3.2Ω	4Ω	1.5Ω	1.8Ω	2Ω	2.3Ω	2.7Ω	3.2Ω	3.2Ω	4Ω	5.3Ω	5.3Ω
	8:8Ω	2Ω	2.7Ω	3.2Ω	1.3Ω	1.6Ω	1.8Ω	2Ω	2.3Ω	2.7Ω	3.2Ω	3.2Ω	4Ω	5.3Ω	5.3Ω	5.3Ω	5.3Ω	5.3Ω	5.3Ω	5.3Ω	5.3Ω	5.3Ω	5.3Ω	5.3Ω	5.3Ω	
	8:16Ω	2.3Ω	3.2Ω	4Ω	1.5Ω	1.8Ω	2Ω	2.3Ω	2.7Ω	3.2Ω	3.2Ω	4Ω	5.3Ω	5.3Ω	5.3Ω	5.3Ω	5.3Ω	5.3Ω	5.3Ω	5.3Ω	5.3Ω	5.3Ω	5.3Ω	5.3Ω	5.3Ω	
	16:16Ω	2.7Ω	3.2Ω	4Ω	5.3Ω	1.6Ω	2Ω	2.3Ω	2.7Ω	3.2Ω	3.2Ω	4Ω	5.3Ω	5.3Ω	5.3Ω	5.3Ω	5.3Ω	5.3Ω	5.3Ω	5.3Ω	5.3Ω	5.3Ω	5.3Ω	5.3Ω	5.3Ω	

The formula for this chart is:

$$\frac{1}{1/R_1 + 1/R_2 + \dots + 1/R_N}$$

Where "R" is the speaker impedance. So, using two 16 ohm speakers in combination with one 8 ohm speaker, the impedance would be:

$$\frac{1}{1/8 + 1/16 + 1/16} = \frac{1}{.125 + .0625 + .0625} = \frac{1}{.250} = 4 \text{ ohm load impedance}$$

You can also figure this on the table. On System One, match the "16:16" column with the System Two "8" row.

Note that some combinations result in impedances less than 2 ohms. (the shaded areas) These combinations are not recommended for the SPA-1400/1400C and should be avoided. They are included on the chart for reference only. Too low an impedance will activate the amplifier's protection circuit.

Power Output:

The power output of an amplifier changes as the total load impedance increases or decreases. The chart below shows the increase in the total output power of the SPA-1400/1400C as the total load impedance decreases:

total load impedance (in ohms):	8 (stereo)	4 (stereo)	2 (stereo)	16 (mono)	8 (mono)	4 (mono)
total output power (watts RMS):	260/channel	425/channel	660/channel	520	850	1320

Output Power Per Speaker Cabinet:

If each parallel connected speaker cabinet has the same rated impedance, divide the total power output by the number of cabinets used. For example: Four 16 ohm cabinets have a total load impedance of 4 ohms (see the impedance chart above), which allows a total output power of 425 watts RMS (Stereo Mode): 400/4 = 108 watts RMS for each cabinet.

Speaker cabinets with different rated impedances will draw different amounts of power. To calculate the power output per cabinet, obtain the total load impedances from the impedance chart above and divide it by each speaker impedance. For example: Three speaker cabinets, one with a rated impedance of 8 ohms and two at 16 ohms are connected in parallel. According to the impedance chart, the total load impedance is 4 ohms, which means a total power output of 425 watts as above. Divide the total impedance by the impedance of each speaker and multiply the results by 425.

$$\frac{R_{\text{total}}}{R_N} = \frac{4/8 = 1/2 \times 425 = 217.5 \text{ watts for the 8 ohm cabinet}}{4/16 = 1/4 \times 425 = 108.75 \text{ watts for each of the 16 ohm cabinets}}$$

Input/Output Connectors:

The SPA-1400/1400C uses both XLR type and 1/4" phone jacks as input connectors for each channel. These inputs accept Medium or Low impedance balanced or unbalanced signals. When using a 1/4" plug to feed a *balanced* signal into the amplifier, tip = signal "+", ring = signal "-", sleeve = ground. When using a 1/4" plug to feed an *unbalanced* signal into the amplifier, tip = signal "+", sleeve = ground. On the SPA-1400C, additional XLR Balanced Thru/X-Over Out jacks are available. Each jack can be in parallel with the XLR and 1/4" input jacks directly below them - set the X-Over Out/Thru switch to the "thru" position (switch not pressed in).

On each channel, both input jacks are wired in parallel; when one jack is used as an input, the remaining jack may be used to obtain a line out signal. In both Mono Modes, Channel 1's input jacks are used; Channel 2's input jacks are disconnected.

Each channel has both 5-way binding posts and a Speakon® jack. A third Speakon® jack is provided for Mono/ Bridge use and can also be used for biamping. On each channel, the binding posts are wired in parallel with the Speakon® jacks. Use of both the binding posts and the Speakon® jacks simultaneously to connect cabinets in parallel is possible, providing proper polarity and impedance is observed.

The Channel A and B Speakon® jacks are wired as follows: pin 1+ = "+", pin 1- = "-". The Mono/Biamp (middle) Speakon® jack is wired as follows: Pins 1+ and 1- = Channel 1 "+" and "-" respectively; pins 2+ and 2- = Channel 2 "+" and "-" respectively. See pages 8 – 20 for Speakon® wiring information.

Installation and Operation:

Stereo Operation:

The SPA-1400/1400C can be used in the Stereo Mode as two separate power amplifiers, each capable of driving loads down to 2 ohms. Each channel operates independently and has its own input connectors, sensitivity level controls, signal indicator LEDs, automatic limiter, fault protection circuitry, power amp, and speaker outputs. In the Stereo Mode, the **MONO/STEREO SWITCHES** (#16 & #17) must both be in the OUT position.

One application of the Stereo Mode is using one channel of the amplifier for the left house speakers and the other for the right. The mixing board channels can be panned left or right according to the position of the instruments on the stage. This way the house sound can reproduce the stereo "spread" of the instruments.

Either the binding posts or the Speakon® jacks may be used to connect the amplifier to the speakers. See the wiring diagram below for the Speakon® jacks.

NOTE: Your speakers may benefit from a low frequency cut, since frequencies below a speaker's low-end response limit can cause distortion or even damage. For this reason, you might consider using an appropriate Low Cut Frequency (see #20 & #21) with your speakers (SPA-1400C only).



CRATE AUDIO SPA-1400/1400C Rack Mount Power Amplifier

Installation and Operation:

Main/Monitor Combinations:

Another application of the Stereo Mode (see page 8) is using one channel of the amplifier for the house speakers and the other for the monitors. The **MONO/STEREO SWITCHES** (#16 & #17) must both be in the OUT position.

Either the binding posts or the Speakon® jacks may be used to connect the amplifier to the speakers. See the wiring diagram below for the Speakon® jacks.

NOTE: Your speakers may benefit from a low frequency cut, since frequencies below a speaker's low-end response limit can cause distortion or even damage. For this reason you might consider using an appropriate Low Cut Frequency (see #19 & #20) with your speakers. Monitor speakers usually need a low cut for best performance (SPA-1400C only).

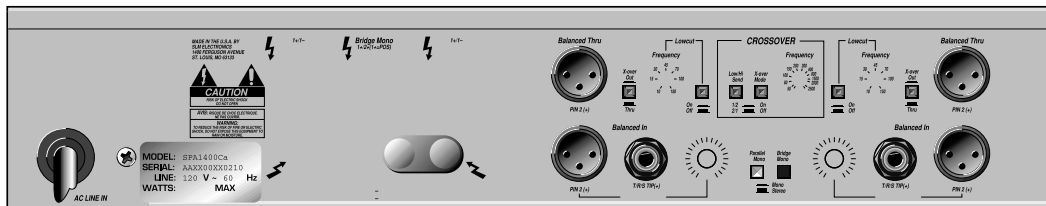

CRATE PRO AUDIO SPA-1400/1400C Rack Mount Power Amplifier

Installation and Operation:

Parallel Mono Operation:

The two internal power amplifiers (channel 1 and 2) can easily be driven by a single input signal. Connect the input signal to channel 1 and press in the **PARALLEL MONO SWITCH** (#16). (The **BRIDGE MONO SWITCH**, #17, must be in the OUT position!) The signal will be fed to both channels, each with its separate level control (#15). (Even though the signal is fed only into channel 1, channel 2's **LEVEL CONTROL** will still adjust the channel 2 output, independent from channel 1's **LEVEL CONTROL**.)

Either the binding posts or the Speakon® jacks may be used to connect the amplifier to the speakers. See the wiring diagram below for the Speakon® jacks. The total speaker impedance must be two ohms or more per channel.

NOTE: Your speakers may benefit from a low frequency cut, since frequencies below a speaker's low-end response limit can cause distortion or even damage. For this reason you might consider using an appropriate Low Cut Frequency (see #20 & #21) with your speakers. Monitor speakers usually need a low cut for best performance (SPA-1400C only).

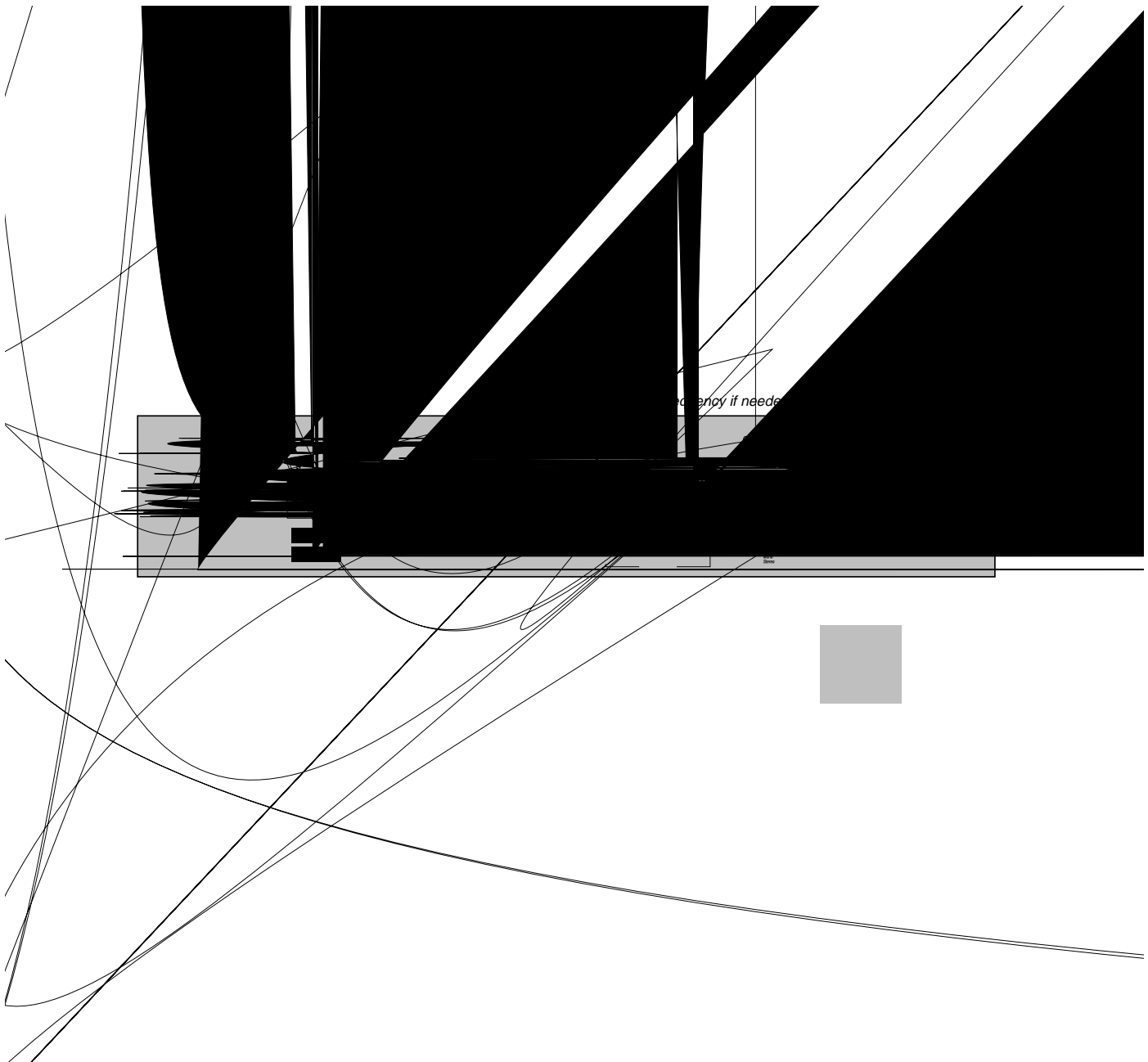

CRATE PRO AUDIO SPA-1400/1400C Rack Mount Power Amplifier

Installation and Operation:

Bridged Mono Operation:

The two internal power amplifiers can be bridged together to form a single, higher-powered amp. In the Bridged Mono Mode, the amplifier uses channel 1's **INPUT** jacks and **LEVEL CONTROL**; channel 2's are disconnected. Channel 2's power amp receives its signal from a tap after channel 1's **LEVEL** control, but prior to channel 2's Limiter, so each channel is independently protected. The **BRIDGE MONO SWITCH** (#17) must be pressed in. Because both channels are being used (bridged in series), the minimum speaker load impedance is 4 ohms.

The RED binding post terminals (ch 1 = "+", ch 2 = "-") or the middle Speakon® jack must be used to connect the amplifier to the speakers. See the wiring diagram below for the Speakon® jack.

NOTE: Your speakers may benefit from a low frequency cut, since frequencies below a speaker's low-end response limit can cause distortion or even damage. For this reason you might consider using an appropriate Low Cut Frequency (see #20 & #21) with your speakers (SPA-1400C only).

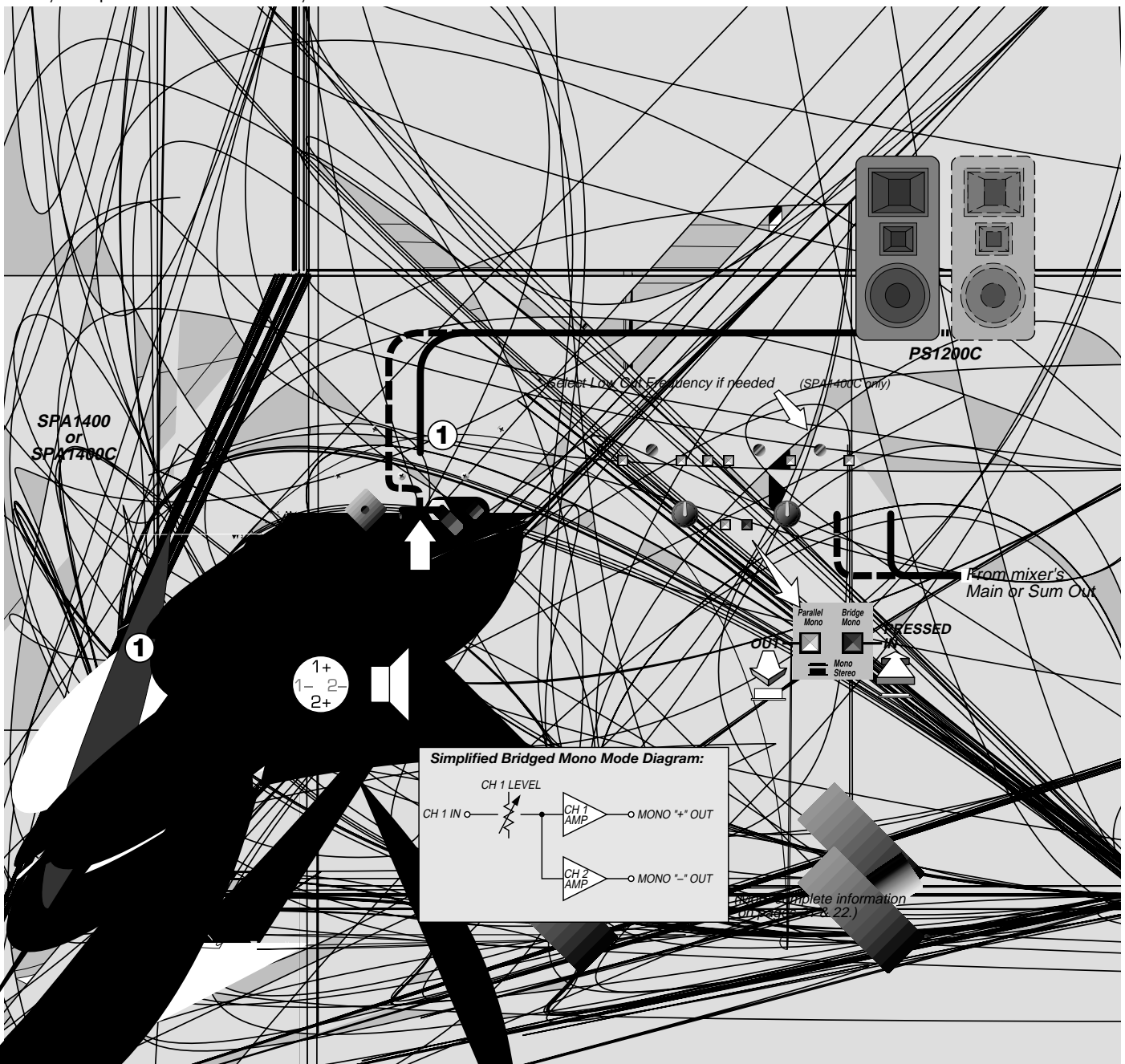

Speakon® is a registered trademark of Neutrik USA

CRATE **PRO AUDIO** SPA-1400/1400C Rack Mount Power Amplifier

Installation and Operation:

Patching Two Bridged Mono Mode Systems:

Two Bridged Mono amplifiers can be patched together by connecting a signal cable between their input jacks (the dashed line in the illustration below). (On the SPA-1400C, another option is connecting a balanced XLR cable from the first amp's **BALANCED THRU** jack [#18] to the XLR input of the next amp – the dotted line below.) The **BRIDGE MONO SWITCH** (#17) must be pressed in. Because both channels are being used (bridged in series), the minimum speaker load impedance must be 4 ohms.

The RED binding post terminals (ch 1 = "+", ch 2 = "-") or the middle Speakon® jack must be used to connect the amplifier to the speakers. See the wiring diagram below for the Speakon® jacks.

NOTE: Your speakers may benefit from a low frequency cut, since frequencies below a speaker's low-end response limit can cause distortion or even damage. For this reason you might consider using an appropriate Low Cut Frequency (see #20 & #21) with your speakers (SPA-1400C only).



CRATE **PRO AUDIO** SPA-1400/1400C Rack Mount Power Amplifier

Installation and Operation:

Connecting Multiple Amplifiers (SPA-1400C only):

A single signal may be passed along to multiple amplifiers by using the **BALANCED THRU/X-OVER OUT** jacks. Set the switches to the "Thru" (OUT) position and connect from the first amplifier's Balanced Thru jack to the next amp's input jack. Make all other connections (from mixer, to speakers, etc.) per normal, as each amplifier/speaker combination requires.

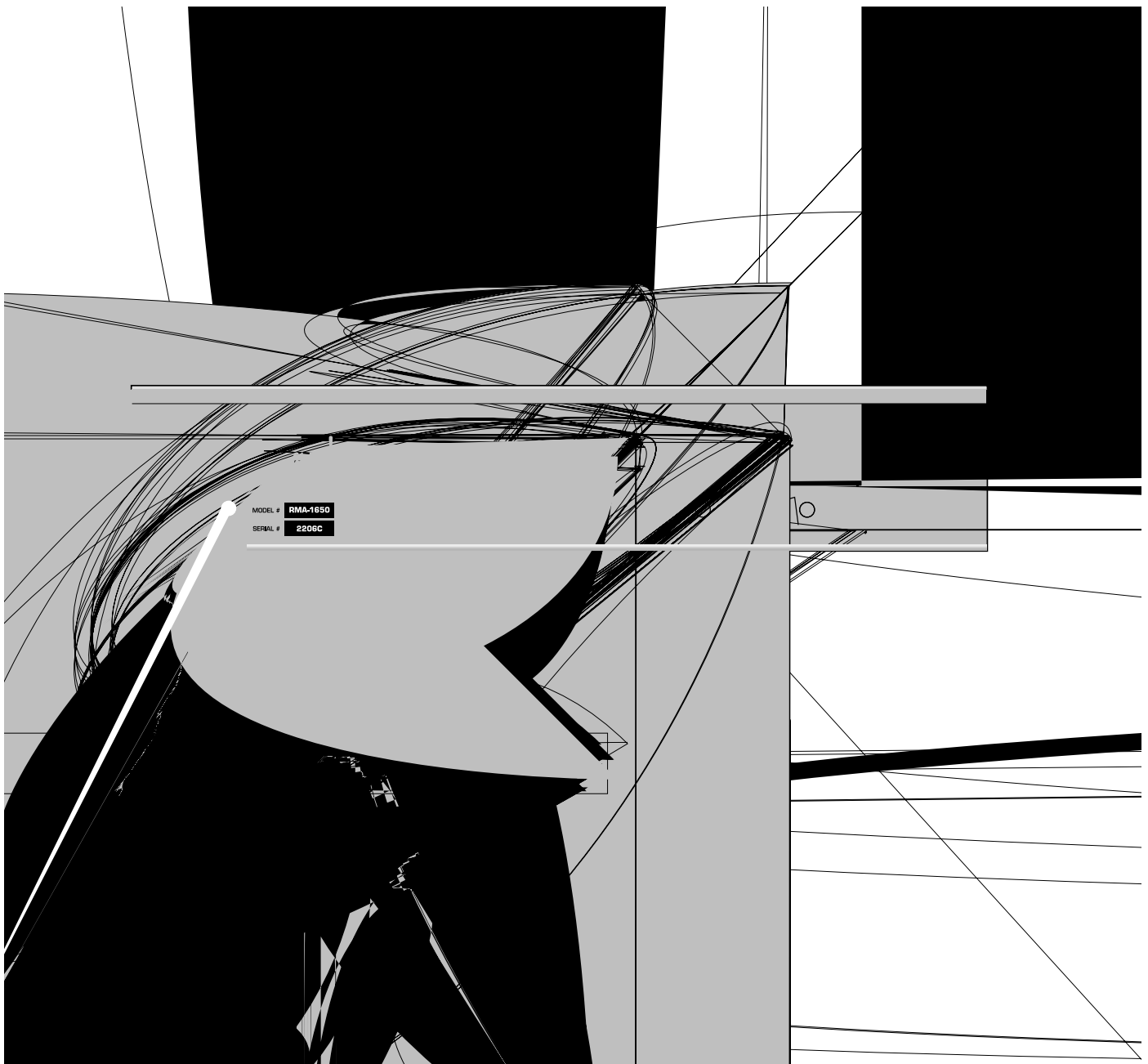

CF

8

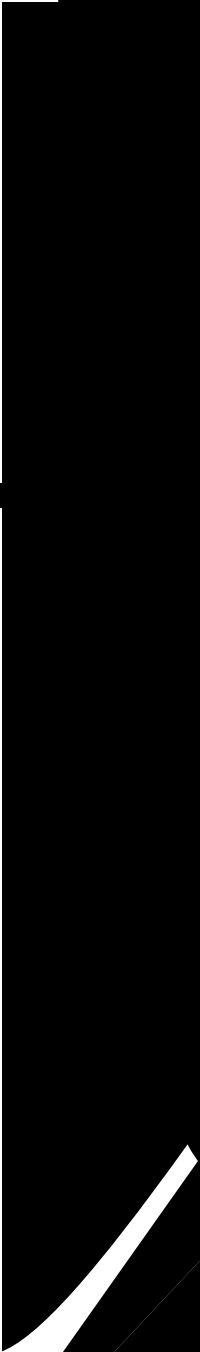

CRATE **SPA-1400/1400C Rack Mount Power Amplifier**

Installation and Operation:

Biamping: SPA-1400 – One Amp, Separate Cabinets:

One SPA-1400 can be used to power separate low and high frequency cabinets. The **MONO/STEREO SWITCHES** (#16 & #17) must both be in the **OUT** position. (We show use of channel 1 for the low frequencies and channel 2 for the highs, but you may choose to use 1 for the highs and 2 for the lows.) A separate external electronic crossover must be added between the mixer and the power amp.

Either the binding posts or the Speakon® jacks may be used to connect the amplifier to the speakers. See the wiring diagram below for the Speakon® jacks.



CRAVE AUDIO SPA-1400/1400C Rack Mount Power Amplifier

Installation and Operation:

Biamping: SPA-1400C – One Stereo Amplifier:

A single SPA-1400C can be used to power separate low and high frequency cabinets (shown below), or to separately power the lows and highs of a cabinet with biamp inputs (for speaker connection information see page 14). The **MONO/STEREO SWITCHES** (#16 & #17) must both be in the OUT position. Here we show using channel 1 for the low frequencies and channel 2 for the highs – you may reverse the channels if desired, as long as the **LOW/HI SEND SWITCH** (#22) is set to “2/1” and the cabinets are reversed from what is shown below. Since the SPA-1400C has a built in active electronic crossover, a separate external electric crossover is not needed – run the output from the mixer directly into channel 1 of the amplifier. Use the **CROSSOVER FREQUENCY CONTROL** (#24) to set the cut off frequency for the low frequency cabinet. The **LEVEL CONTROLS** (#15) allow proper balancing of low and high frequency volume levels.

Either the binding posts or the Speakon® jacks may be used to connect the amplifier to the speakers. See the wiring diagram below for the Speakon® jacks.

NOTE: Your speakers may benefit from a low frequency cut, since frequencies below a speaker’s low-end response limit can cause distortion or even damage. For this reason you might consider using an appropriate Low Cut Frequency (see #20& #21) with your speakers (SPA-1400C only). (Even some subwoofers perform better with an appropriate low frequency cut.)

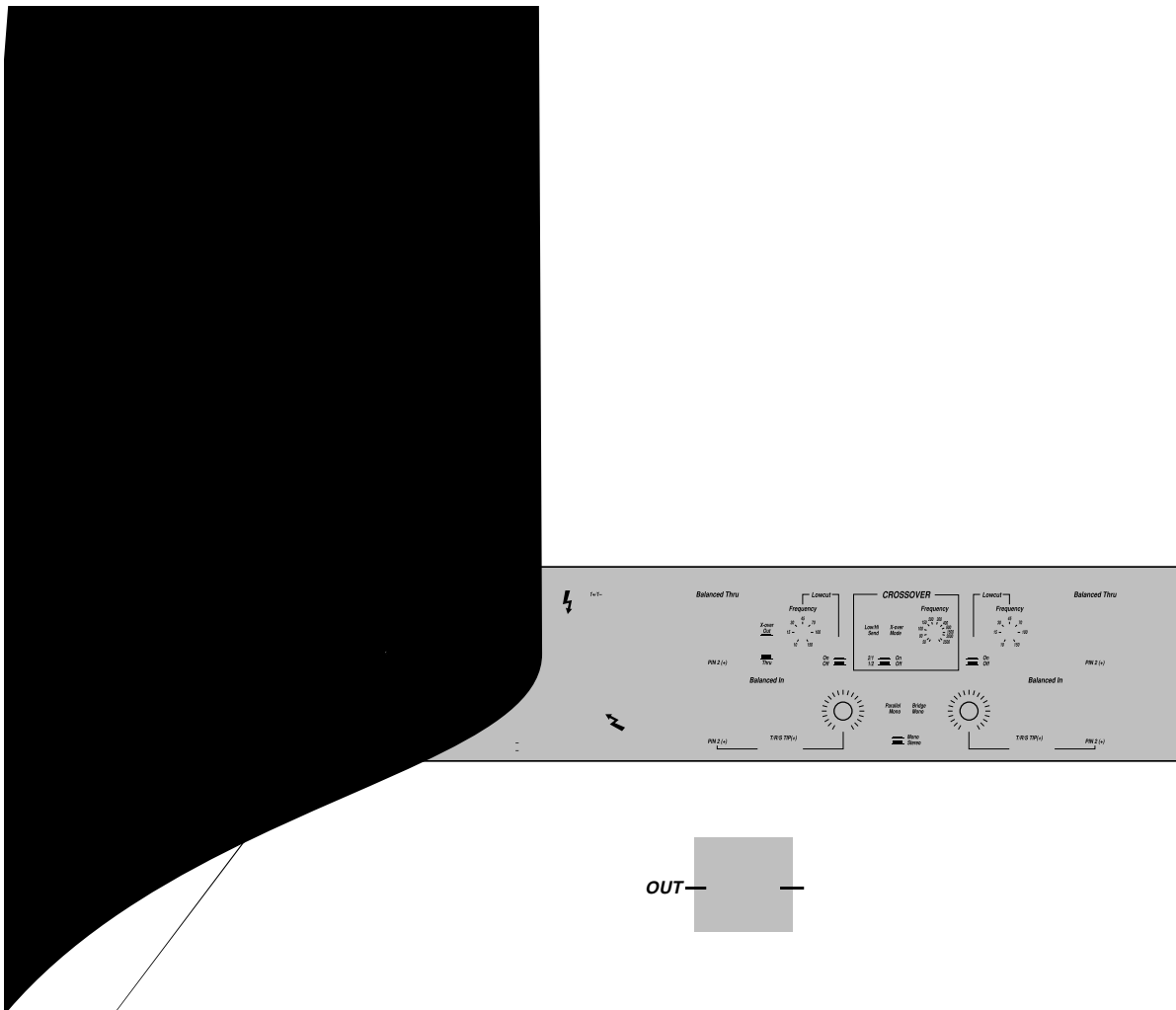

CRATE PRO AUDIO SPA-1400/1400C Rack Mount Power Amplifier

Installation and Operation:

Biamping: SPA-1400C – Multiple Amplifiers:

A single SPA-1400C can be used to power separate low and high frequency cabinets (shown below), and to connect additional biamped speakers, using multiple amplifiers. The **MONO/STEREO SWITCHES** (#16 & #17) must both be in the OUT position. Here we show using channel 2 for the low frequencies and channel 1 for the highs – you may reverse the channels if desired, as long as the **LOW/HI SEND SWITCH** (#22) is set to “1/2” and the cabinets are reversed from what is shown below. Since the SPA-1400C has a built in active electronic crossover, a separate external electric crossover is not needed – run the output from the mixer directly into channel 1 of the amplifier. Use the **CROSSOVER FREQUENCY CONTROL** (#24) to set the cut off frequency for the low frequency cabinet. The **LEVEL CONTROLS** allow proper balancing of low and high frequency volume levels.

Connect the additional amplifier/speaker combinations to the SPA-1400C’s **BALANCED THRU/X-OVER** jacks (#18). The **X-OVER OUT/THRU** switches (#19) must each be pressed in.

Either the binding posts or the Speakon® jacks may be used to connect the amplifier to the speakers. See the wiring diagram below for the Speakon® jacks.

You could also use the SPA-1400C for lows only, or even for full range, while still sending low and high crossover outputs to the other amplifiers. Remember that the crossover is always active and crossover output is always available externally even if the **X-OVER MODE** switch (#23) is in the “off” position (not pressed in). (See page 6 for a review).

NOTE: Your speakers may benefit from a low frequency cut, since frequencies below a speaker’s low-end response limit can cause distortion or even damage. For this reason you might consider using an appropriate Low Cut Frequency (see #20 & #21) with your speakers (SPA-1400C only). (Even some subwoofers perform better with an appropriate low frequency cut.)

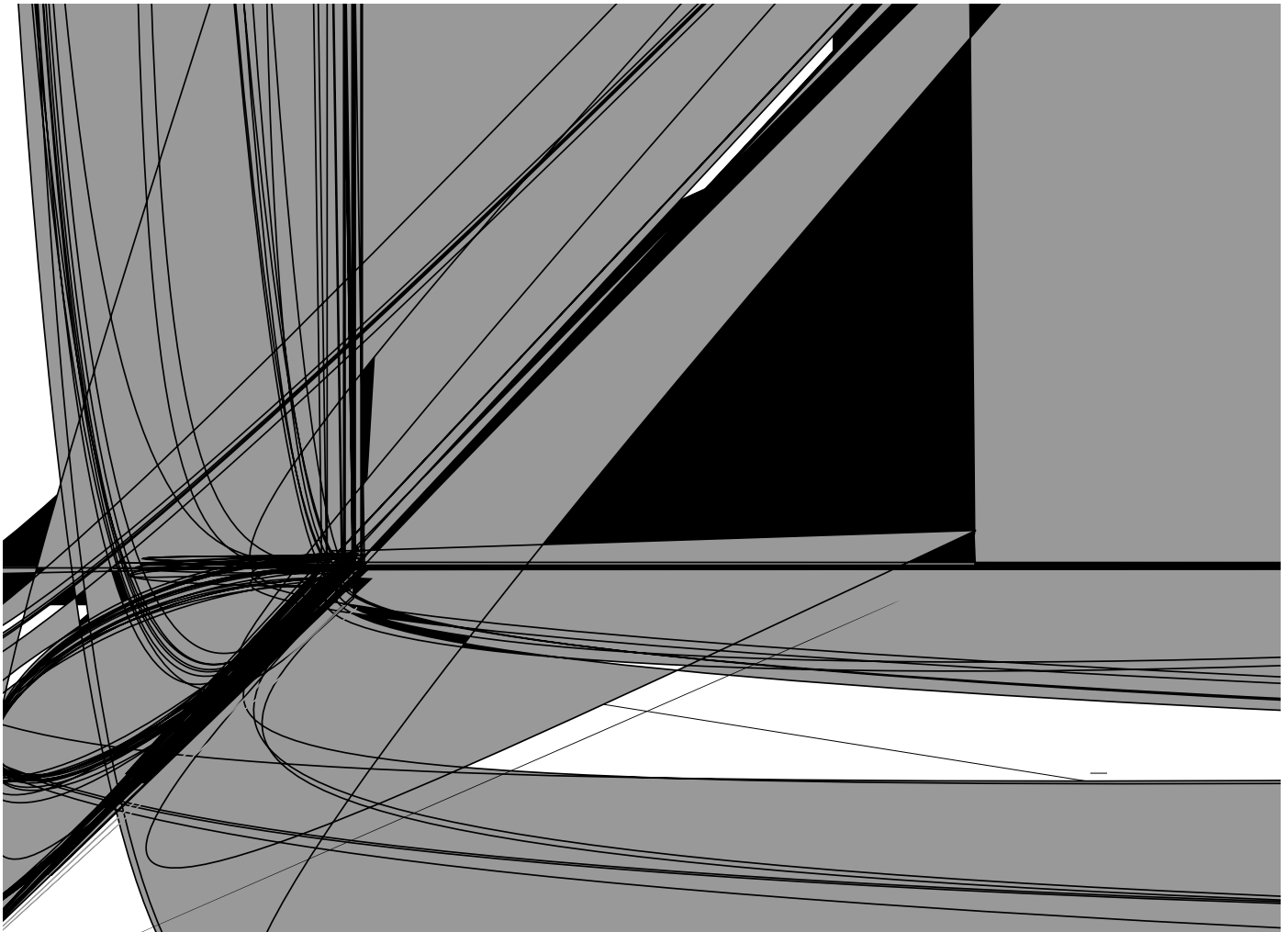

CRATE **PRO AUDIO** SPA-1400/1400C Rack Mount Power Amplifier

Installation and Operation:

Biamping: SPA-1400C – Two Mono Bridged Amplifiers:

A pair of SPA-1400C can be used to power separate low and high frequency cabinets. The **BRIDGE MONO SWITCH** (#17) of each amplifier must both be in the IN position. Use one amplifier for the low frequencies and the other for the highs. Since the SPA-1400C has a built in active electronic crossover, a separate external electronic crossover is not needed – run the output from the mixer directly into channel 1 of the low frequency amplifier.

Connect channel 2's **BALANCED THRU/X-OVER OUT** jack (#18) of the low frequency amplifier to the **INPUT** of the high frequency amplifier. The **X-OVER OUT/THRU** switches (#19) must each be pressed in. Use the **CROSSOVER FREQUENCY CONTROL** (#24) of the low frequency amplifier to set the cut off frequency for the low frequency cabinet. (You may alternately use the first SPA-1400C as the high frequency amp if you set the **LOW/HI SEND SWITCH** (#22) to "2/1" and reverse the cabinets from what is shown below.)

Either the binding posts or the Speakon® jacks may be used to connect the amplifiers to the speakers. See the wiring diagram below for the Speakon® jacks.

NOTE: Your speakers may benefit from a low frequency cut, since frequencies below a speaker's low-end response limit can cause distortion or even damage. For this reason you might consider using an appropriate Low Cut Frequency (see #20 & #21) with your speakers (SPA-1400C only). (Even some subwoofers perform better with an appropriate low frequency cut.)



1180/1180C 2-Channel Power Amplifier

power separate low, mid and high frequency cabinets, or a separate subwoofer and
le shown by

CRAFTER PRO AUDIO SPA-1400/1400C Rack Mount Power Amplifier

Installation and Operation:

Triamping: SPA-1400C:

A pair of SPA-1400Cs can be used to power separate low, mid and high frequency cabinets, or a separate subwoofer and biamped full range cabinet. In the example shown, a bridged mono subwoofer, the **BRIDGE MONO SWITCH** (#17) of the low frequency amplifier must be in the IN position; the **MONO/STEREO SWITCHES** (#16 & #17) of the mid/high frequency amplifier must both be in the OUT position. Use channel 1 of the mid/high amp for the low/mid frequencies and channel 2 for the highs. Since the SPA-1400Cs have built in active electronic crossovers, separate external electronic crossovers are not needed – run the output from the mixer directly into channel 1 of the low frequency amplifier.

Connect the additional amplifier/speaker combinations to the SPA-1400C's **BALANCED THRU** jacks - .

Connect the channel 2 **BALANCED THRU/X-OVER OUT** jack (#18) of the low frequency amplifier to the **INPUT** jack of the mid/high frequency amplifier. The channel 2 **X-OVER OUT/THRU** switch (#19) must be pressed in. Use the **CROSSOVER FREQUENCY CONTROLS** (#24) of each amplifier to set the cut off frequencies for each cabinet.

Either the binding posts or the Speakon® jacks may be used to connect the amplifiers to the speakers. See the wiring diagrams below for the Speakon® jacks.

NOTE: Your speakers may benefit from a low frequency cut, since frequencies below a speaker's low-end response limit can cause distortion or even damage. For this reason you might consider using an appropriate Low Cut Frequency (see #20 & #21) with your speakers (SPA-1400C only). (Even some subwoofers perform better with a slight low frequency cut.)

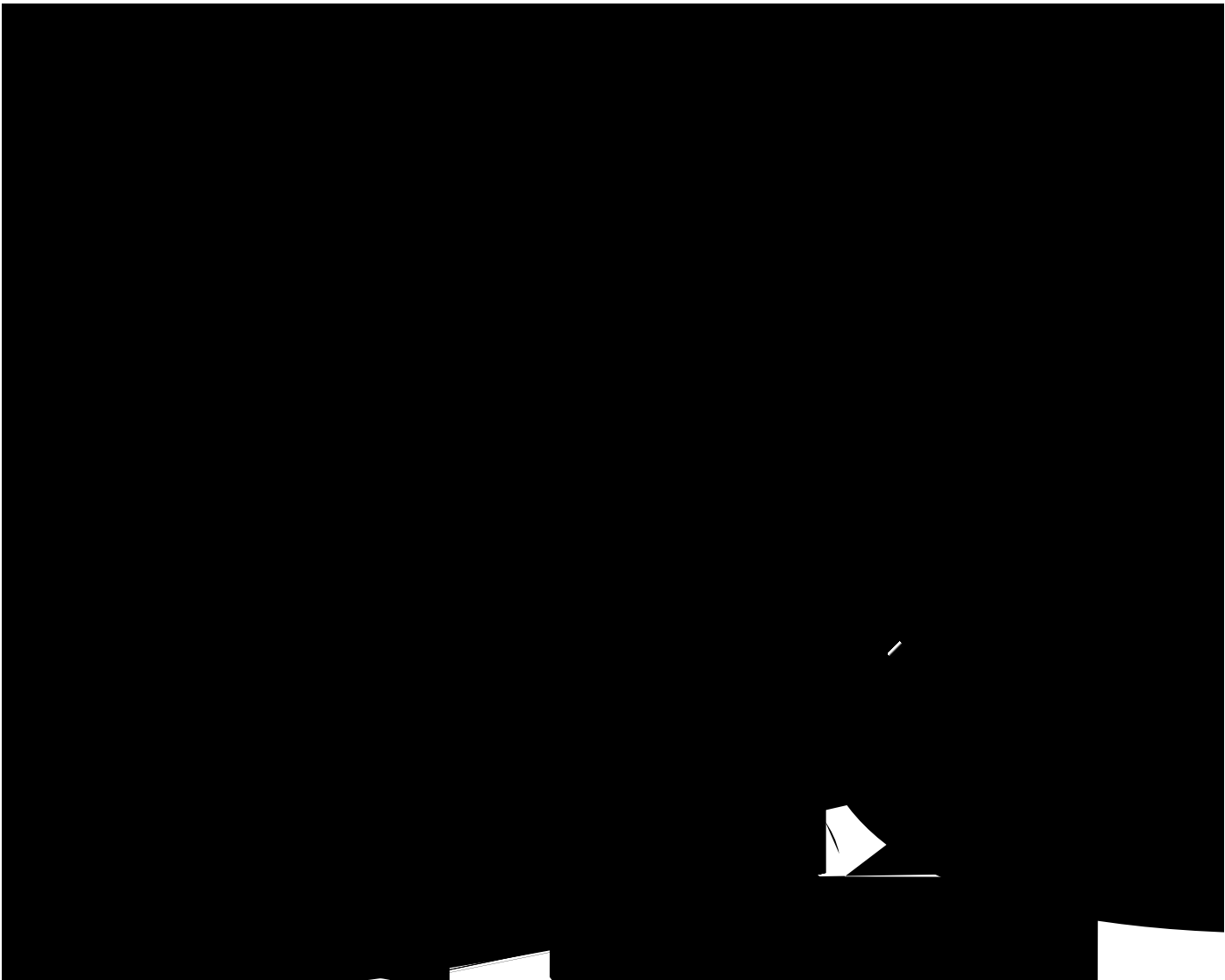

CRATE PA SPA-1400/1400C Rack Mount Power Amplifier

System Block Diagram, SPA-1400:

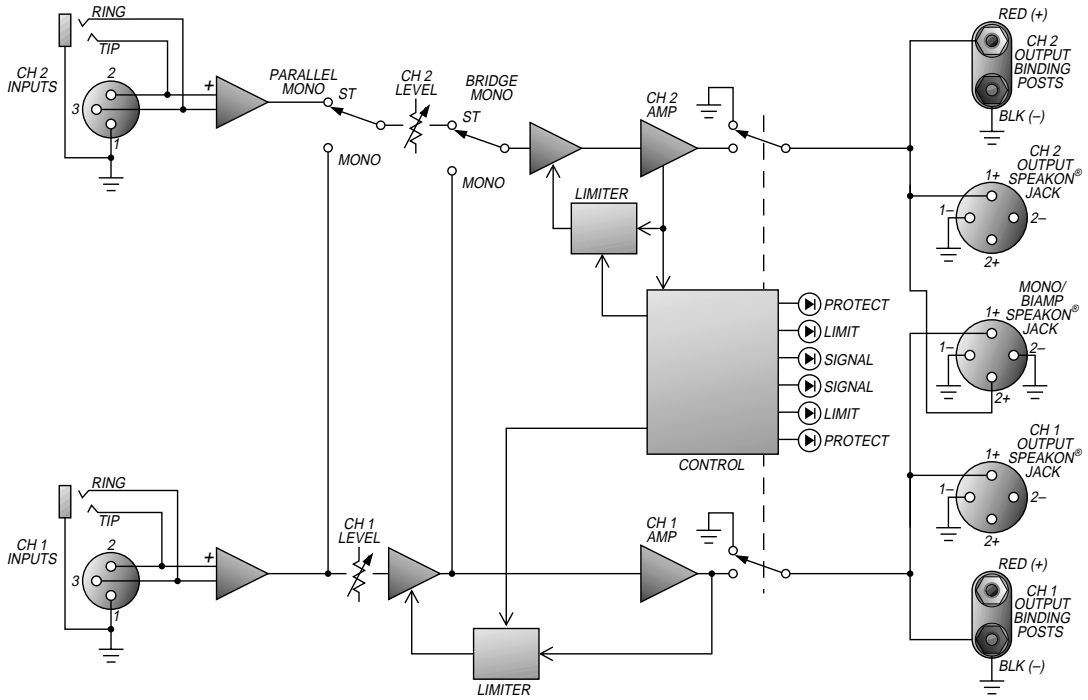

System Block Diagram, SPA-1400C:

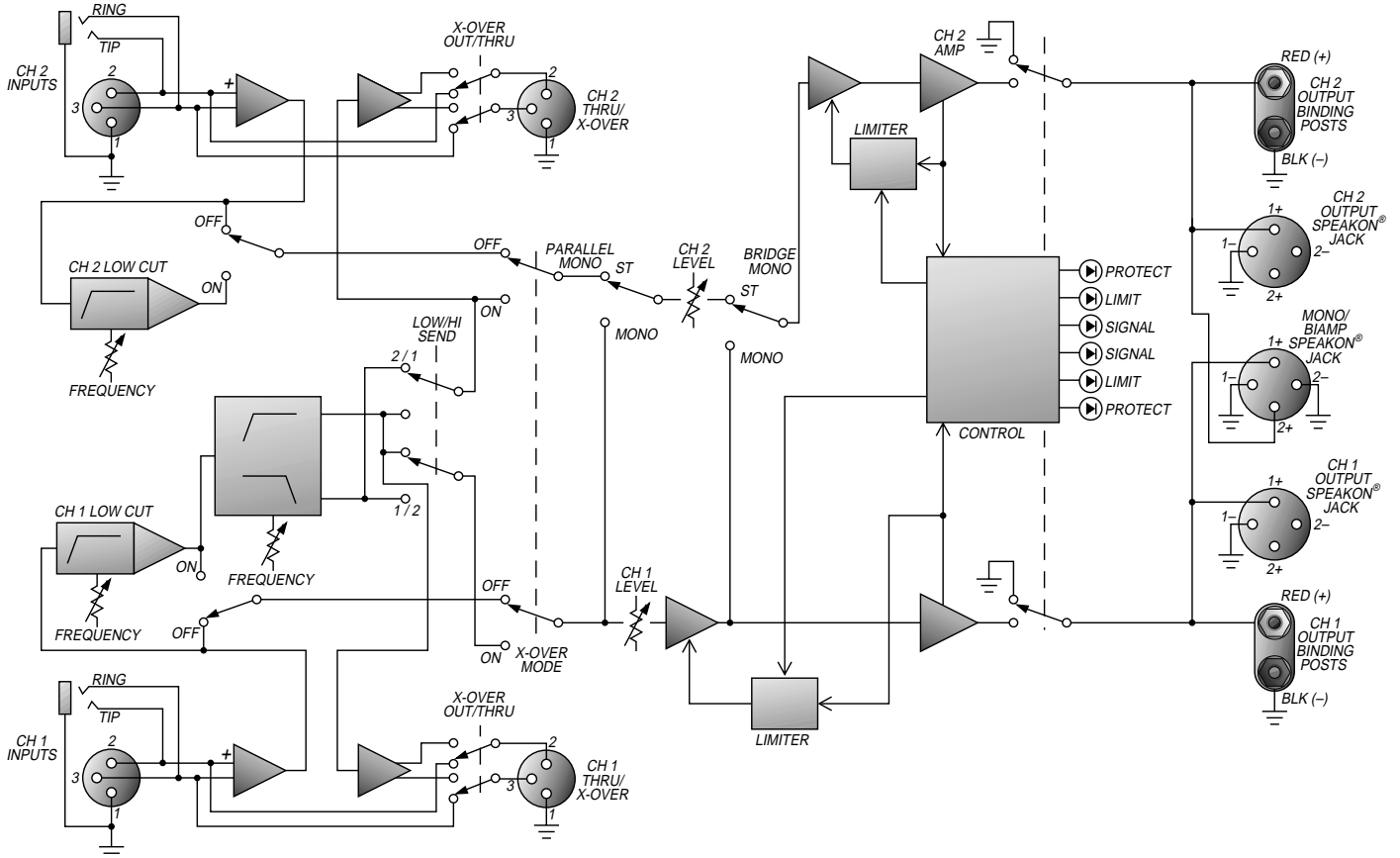

CRA TE SPA-1400/1400C Rack Mount Power Amplifier

Mode Block Diagrams:

The following diagrams are excerpts from the system block diagrams and are intended to provide a simplified view of the three operating modes of the amplifier. For more complete information please refer to the text on page 5 (items #16 & 17), and the text and/or illustrations on pages 8 – 21.

Stereo Mode:

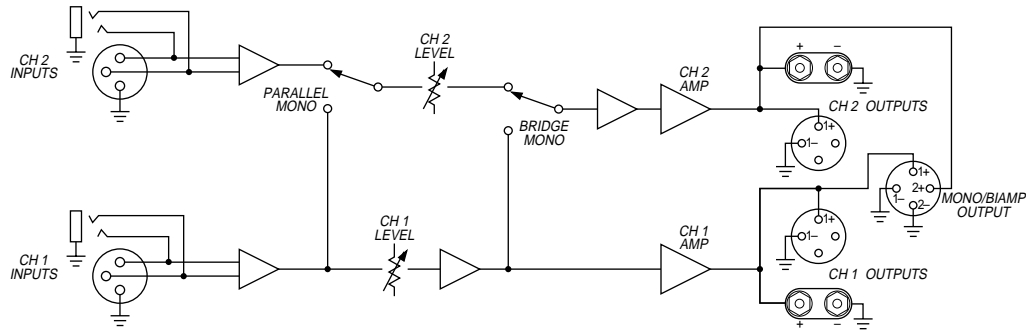

Parallel Mono Mode:

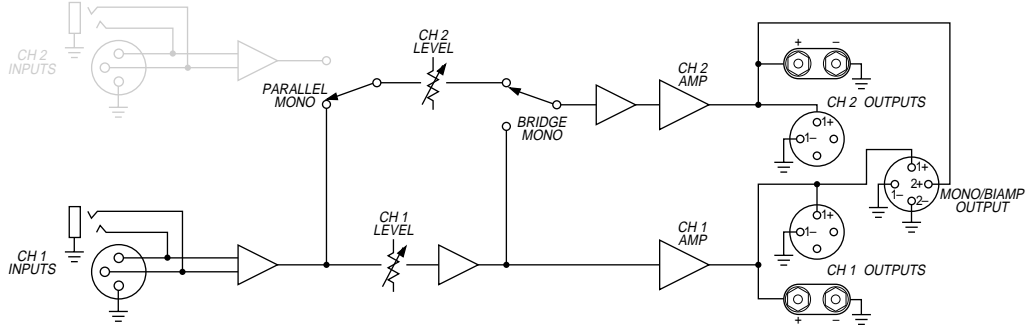

Bridge Mono Mode:

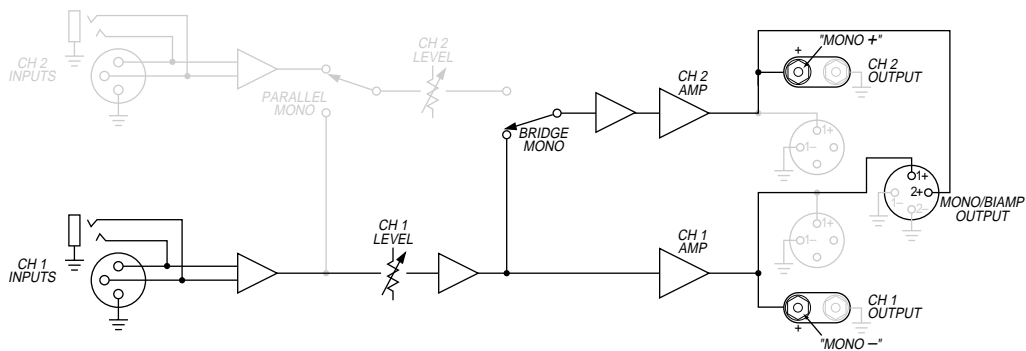

CRATE AUDIO SPA-1400/1400C Rack Mount Power Amplifier

Technical Specifications

POWER OUTPUT	Stereo Mode: 260 watts / channel @ 8 ohms 20Hz–20kHz 425 watts / channel @ 4 ohms 20Hz–20kHz 660 watts / channel @ 2 ohms 1kHz Bridged Mono Mode: 520 watts / channel @ 16 ohms 20Hz–20kHz 850 watts / channel @ 8 ohms 20Hz–20kHz 1320 watts / channel @ 4 ohms 1kHz
FREQUENCY RESPONSE	+0/-.4dB, 20Hz – 20kHz
TOTAL HARMONIC DISTORTION	< .25%, 20Hz–20kHz @ 400 watts / channel 4 ohms (typically .05% @ 1kHz)
SLEW RATE	40 volts / microsecond
SIGNAL TO NOISE RATIO	> 100dB ref 400 watts / 4 ohms (20kHz equivalent bandwidth)
LOAD IMPEDANCE	Stereo Mode 2 ohms or greater Mono Mode 4 ohms or greater
DAMPING FACTOR	Typical 250 (1kHz, 8 ohms)
CONTROLS	Two rear panel level setting knobs
INPUT CONNECTIONS	XLR and 1/4" phone (tip/ring/sleeve), one each channel
OUTPUT CONNECTIONS	5-way binding posts each channel, Speakon® jacks (one each channel, one for Mono/Biamp)
MODE SWITCHES	Mono Bridge mode select, Parallel Mono mode select
LOW CUT FREQUENCY (SPA-1400C)	10Hz – 15-Hz
CROSSOVER FREQUENCY RANGE	50Hz – 2.5kHz
XLR "THRU/X-OVER OUT" (SPA-1400C)	Switchable: Directly paralleled to XLR Input jacks / high & low crossover output
PROTECTION CIRCUITRY	Short circuit, open circuit, RF burnout, overtemp, speaker protection relays, turn on/off transient protection, DC protection and built-in auto-limiter (Anti-clip)
COOLING	Variable speed forced air fan cooling, rear/side intake, front exhaust
POWER REQUIREMENTS	DOMESTIC: 120 VAC 60Hz, 1100VA EXPORT: 100-115 VAC 50/60Hz, 1100VA 220-240 VAC 50/60Hz, 1100VA
SIZE AND WEIGHT	19" W x 3.5" H x 17.73" D; 36 lbs.

Speakon® is a registered trademark of Neutrik USA

Due to ongoing product development and improvement, the specifications contained herein are subject to change without notice.

CRATE AUDIO

www.crateamps.com

©1999 SLM Electronics, Inc. • A Division of St. Louis Music, Inc.
1400 Ferguson Avenue • St. Louis, MO 63133

47-658-01 • 01/99

Download from Www.Somanuals.com. All Manuals Search And Download.



Free Manuals Download Website

<http://myh66.com>

<http://usermanuals.us>

<http://www.somanuals.com>

<http://www.4manuals.cc>

<http://www.manual-lib.com>

<http://www.404manual.com>

<http://www.luxmanual.com>

<http://aubethermostatmanual.com>

Golf course search by state

<http://golfingnear.com>

Email search by domain

<http://emailbydomain.com>

Auto manuals search

<http://auto.somanuals.com>

TV manuals search

<http://tv.somanuals.com>