

PZM[®]-11 PZM-11LL

The Crown[®] PZM[®]-11 or PZM-11LL is a Pressure Zone Microphone[®] designed for conference-room, security and surveillance applications. Each can be mounted in the ceiling or wall in a standard electrical outlet box. Providing excellent intelligibility, the PZM-11 and PZM-11LL are designed to look like a light switch so as not to draw attention.

The **PZM-11** has a mic-level output and is powered by 12-48V phantom power.

The **PZM-11LL** has a line-level output and can be powered by 24V AC, 12-24V DC, or 12-48V phantom power. Since the PZM-11LL has a high output, it can be plugged directly into a VCR line input—no costly mic preamp is needed.

To phantom power the PZM-11LL, a modification will have to be made to the electronics module (see Installation Step 3 for details).

Like other Pressure Zone Microphones, the PZM-11 and PZM-11LL utilize the Pressure Recording Process[™] in which a miniature condenser microphone capsule is mounted very close to a sound-reflecting plate or boundary. The capsule is mounted in the "Pressure Zone" just above the boundary, a region where sound coming directly from the sound source combines in-phase with sound reflected off the boundary. The benefits are a wide, smooth frequency response free of phase interference, excellent clarity and "reach," and consistent pickup anywhere around the microphone.

In the PZM-11 and PZM-11LL, low frequencies below the voice range are rolled off to reduce pickup of air-conditioning rumble. The high-frequency response is boosted slightly to aid clarity and articulation.

The microphone connector is a row of screw terminals for easy installation. The output is balanced, low impedance, which allows long cable runs without hum pickup or high-frequency loss.

Installation

1. Please refer to Fig. 3 (PZM-11) or Fig. 4 (PZM-11LL) and locate all the parts shown.
2. Run a 2-conductor shielded mic cable to the hole where you intend to install the microphone. Install a standard electrical outlet box in the hole.

To use phantom power, you need a mixer with phantom power or an external phantom-power supply. Crown makes a PH-1A phantom power supply which has 1 channel and is AC-adaptor powered.

(Continued on back)

PRESSURE ZONE MICROPHONES



Features

- Ideal for security, surveillance and conference rooms
- Clear, articulate sound
- Low-impedance screw-terminal output
- Inconspicuous
- PZM-11 is mic level; PZM-11LL is line level

Specifications

Type: Pressure Zone Microphone.

Element: Electret condenser.

Frequency response (typical): 80 Hz to 20,000 Hz. See Fig. 1.

Polar pattern: Hemispherical.

Impedance:

PZM-11: 225 ohms, balanced.

PZM-11LL: 75 ohms, balanced.

Recommended minimum load impedance 1000 ohms.

Open circuit sensitivity:

PZM-11: 5 mV/Pa* (-46 dBV/Pa).

PZM-11LL: 1.4V/Pa* (+3 dB re 1V/Pa).

Power sensitivity:

PZM-11: -45.5 dBm/Pa*

PZM-11LL: +8 dBm/Pa*.

Equivalent noise level (self-noise): 26 dB SPL typical (0 dB = .0002 dyne/cm²), A-weighted.

S/N Ratio: 68 dB at 94 dB SPL.

Maximum SPL:

PZM-11: 120 dB SPL produces 3% THD.

PZM-11LL: 100 dB SPL produces 3% THD.

Output connector:

Three screw terminals.
1 = ground, 2 = audio hot (in polarity),
3 = audio cold (opposite polarity).

Polarity: Positive pressure on the diaphragm produces a positive voltage on screw terminal 2 with respect to screw terminal 3.

Operating voltage:

PZM-11: Standard phantom power, 12 to 48V DC on screw terminals 2 and 3 with respect to screw terminal 1.

PZM-11LL: 24V AC, 12-24V DC, or phantom power as the PZM-11LLS2.

Current drain:

PZM-11: 400 microamperes.

PZM-11LL: 4 milliamperes.

Materials: Steel plate and high-impact plastic capsule holder.

Finish: Off-white. May be painted any color; take care to first seal the opening between the mic capsule and boundary plate.

Operating Temperature Range: -10° to +60° C (+14° to +140° F).

Net weight: 2.5 oz. (71 g).

Dimensions: See Fig. 2.

Optional accessories: Crown PH-1A phantom power supply (1 channel, AC-adaptor powered).

*1 pascal = 10 dynes/cm² = 10 microbars = 94 dB SPL.

Fig. 1. Frequency Response

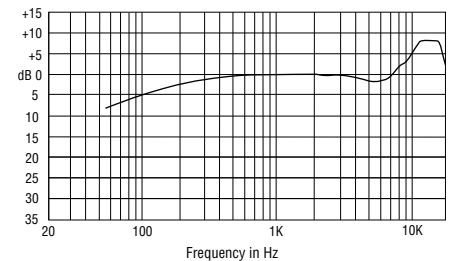
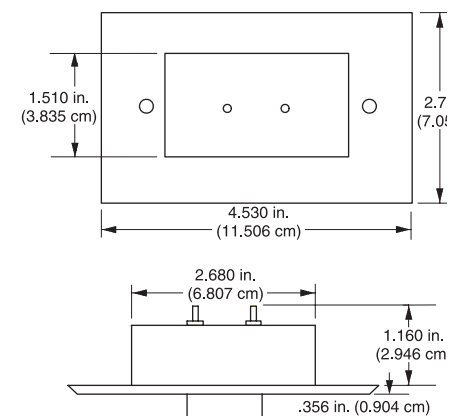

Fig. 2. Dimensions





PZM-11 PZM-11LL

3. This entire step is for the PZM-11LL only. The PZM-11LL can be powered in three ways: 24V AC, 12-24V DC, or 12-48V phantom power. The mic is factory-wired for 24V AC powering so that it is compatible with video surveillance systems where 24V AC is readily available.

To use phantom power with the PZM-11LL: Put R14 in R13's space; put R15 in R16's space (the resistors are labeled on the circuit board). Note: In some cases these resistors may be on the bottom side of the board. Do not overheat. Then proceed to step 4.

To use 24V AC or 12-24V DC with the PZM-11LL: From your power source, run a twisted pair of power cable to the ceiling or wall hole. Run the power cable through the hole in the electrical box (if any) and through either hole in the chassis (Fig. 4). Service the end of the power cable.

To use 24V AC with the PZM-11LL: Attach the power leads to the screw terminals labeled 24V AC INPUT.

To use 12-24V DC with the PZM-11LL: See Fig. 5. Connect the positive lead from the DC source to either screw terminal of the INPUT terminal block. Connect the negative lead to the other terminal of the INPUT terminal block.

4. Run the mic cable through the hole in the electrical box (if any) and through either hole in the chassis (Fig. 4). Service the end of the mic cable.

5. Attach your mic-cable leads to the screw terminals labeled OUTPUT. Connect the mic-cable shield to 1, audio + lead to 2, and audio - lead to 3. See Figures 5 and 6.

6. Place the chassis over the two long screws. Using the nuts provided, secure the chassis to the faceplate.

7. Using the two screws provided, secure the faceplate to the electrical box or wall board.

8. If you plan to use an XLR-type cable connector: Solder the cable shield to pin 1, audio + lead to pin 2 and audio - lead to pin 3 of the XLR.

If you plan to use an RCA or phone connector: Solder the cable shield to the long lug, and solder the audio + lead to the tip or pin. Do not connect the audio - lead because this may reduce the output level in an unbalanced configuration.

9. If the mic cable is run in metal conduit, ground loops can occur that can cause hum. If hum is present after installation, unsolder the chip resistor labeled 000 on the printed-circuit board (R21 GND LIFT in Fig. 5).

10. If you plan to use a cable connector, solder the other end of the mic cable to a 3-pin professional audio connector (XLR-type). Solder the cable shield to pin 1, light-colored lead to pin 2, and darker lead to pin 3.

If the PZM-11LL distorts, change resistor R5 labeled GAIN to increase headroom. Do not overheat. The surface-mount resistors listed below are already on the circuit board. See Fig. 5.

1K	minimum headroom
2K	6 dB more headroom
3.9K	12 dB more headroom
8.2K	18 dB more headroom
100K	maximum headroom (mic level)

Architects' and Engineers' Specifications

PZM-11

The microphone shall be the Crown Model PZM-11. The microphone shall be a Pressure Zone Microphone, electret-condenser type, with built-in electronics interface. The microphone capsule holder shall be mounted on a standard switch plate. The microphone shall be powered from 12-48V phantom power. The output shall be low impedance balanced. Frequency response shall be from 80 Hz to 20,000 Hz. Low frequencies below the voice range shall be rolled off. Open-circuit sensitivity shall be 5 mV/Pa (-46 dB re 1V/Pa). Maximum SPL capability shall be 120 dB SPL at 3% THD. Equivalent noise shall be 26 dBA typical (0 dB = .0002 dyne/cm²). The Crown model PZM-11 microphone is specified.

PZM-11LL

The microphone shall be the Crown model PZM-11LL. It shall be a Pressure Zone Microphone, mountable in a wall or ceiling, and designed not to look like a microphone. It shall have a line-level output (1.4 V/Pa unloaded) and be powered by 24V AC, 12-24V DC, or phantom power. The frequency response shall be from 80 Hz to 20,000 Hz with a low-frequency rolloff to reduce rumble and high-frequency boost for articulation. The

Fig. 3. Wiring for Phantom Power

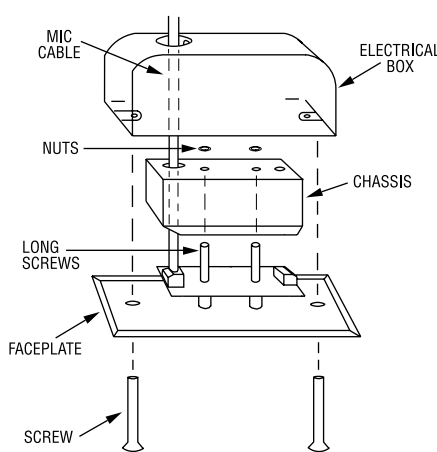
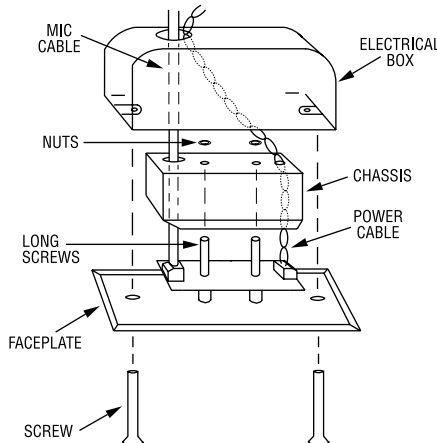

Fig. 4. PZM-11LL Wiring for 24V AC or 12-24V DC



audio connector and power connector shall be screw terminals. Output shall be balanced, low impedance. The electret condenser transducer shall have a hemispherical polar pattern when the microphone is mounted in a wall or ceiling. The Crown PZM-11LL microphone is specified.

Warranty

Crown professional microphones are guaranteed against malfunction for a period of three years from date of original purchase. See enclosed warranty sheet for additional information.

Service

If the unit fails to work, first replace or repair the mic cables and check the power supply. Recheck your connections to the microphone screw terminals. If service is required, return the microphone and the electronic interface in its original packaging to: **Crown Factory Service, 1718 West Mishawaka Road, Elkhart, IN 46517-9439. A Service Return Authorization (SRA) is required for product being sent to the factory for service. An SRA can be completed on line at www.crownaudio.com/support/factserv.htm.** For further assistance or technical support call 800-342-6939.

Fig. 5. PZM-11LL DC Powering and Output Wiring

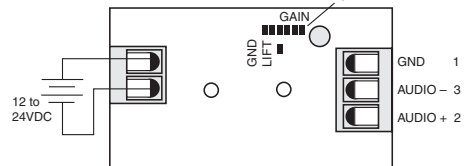
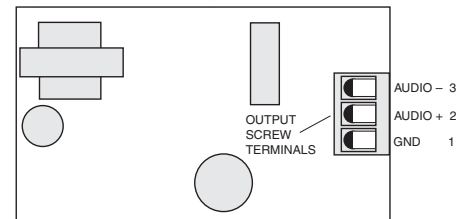

Fig. 6. PZM-11 Output Wiring



H A Harman International Company

Crown International, Inc.
1718 W. Mishawaka Rd.
Elkhart, IN 46517-9439
TEL: 574-294-8000
FAX: 574-294-8FAX
www.crownaudio.com

©2008 Crown Audio®, Inc. Specifications subject to change without prior notice. Latest information available at www.crownaudio.com. Crown, Crown Audio, PZM and Pressure Zone Microphone are registered trademarks of Crown International. Pressure Recording Process is a trademark of E. M. Long Associates.

6/08

136455-6

Free Manuals Download Website

<http://myh66.com>

<http://usermanuals.us>

<http://www.somanuals.com>

<http://www.4manuals.cc>

<http://www.manual-lib.com>

<http://www.404manual.com>

<http://www.luxmanual.com>

<http://aubethermostatmanual.com>

Golf course search by state

<http://golfingnear.com>

Email search by domain

<http://emailbydomain.com>

Auto manuals search

<http://auto.somanuals.com>

TV manuals search

<http://tv.somanuals.com>