



Commercial Audio Series

Operation Manual



180MA

1160MA

280MA

Obtaining Other Language Versions: To obtain information in another language about the use of this product, please contact your local Crown Distributor. If you need assistance locating your local distributor, please contact Crown at 574-294-8000.

This manual does not include all of the details of design, production, or variations of the equipment. Nor does it cover every possible situation which may arise during installation, operation or maintenance.

The information provided in this manual was deemed accurate as of the publication date. However, updates to this information may have occurred. To obtain the latest version of this manual, please visit the Crown website at www.crownaudio.com.

Trademark Notice: Crown, Crown Audio and Amcron are registered trademarks of Crown International. Other trademarks are the property of their respective owners.

Some models may be exported under the name Amcron.®

©2005 by Crown Audio® Inc., 1718 W. Mishawaka Rd., Elkhart, Indiana 46517-9439 U.S.A. Telephone: 574-294-8200

Important Safety Instructions

- 1) Read these instructions.
- 2) Keep these instructions.
- 3) Heed all warnings.
- 4) Follow all instructions.
- 5) Do not use this apparatus near water.
- 6) Clean only with a dry cloth.
- 7) Do not block any ventilation openings. Install in accordance with the manufacturer's instructions.
- 8) Do not install near any heat sources such as radiators, heat registers, stoves, or other apparatus (including amplifiers) that produce heat.
- 9) Do not defeat the safety purpose of the polarized or grounding-type plug. A polarized plug has two blades with one wider than the other. A grounding-type plug has two blades and a third grounding prong. The wide blade or the third prong is provided for your safety. If the provided plug does not fit into your outlet, consult an electrician for replacement of the obsolete outlet.
- 10) Protect the power cord from being walked on or pinched, particularly at plugs, convenience receptacles, and the point where they exit from the apparatus.
- 11) Only use attachments/accessories specified by the manufacturer.
- 12) Use only with a cart, stand, tripod, bracket, or table specified by the manufacturer, or sold with the apparatus. When a cart is used, use caution when moving the cart/apparatus combination to avoid injury from tip-over.
- 13) Unplug this apparatus during lightning storms or when unused for long periods of time.
- 14) Refer all servicing to qualified service personnel. Servicing is required when the apparatus has been damaged in any way, such as power-supply cord or plug is damaged, liquid has been spilled or objects have fallen into the apparatus, the apparatus has been exposed to rain or moisture, does not operate normally, or has been dropped.



- 15) WARNING: TO REDUCE THE RISK OF FIRE OR ELECTRIC SHOCK, DO NOT EXPOSE THIS APPARATUS TO RAIN OR MOISTURE.
- 16) DO NOT EXPOSE TO DRIPPING OR SPLASHING. DO NOT PLACE OBJECTS FILLED WITH LIQUID, SUCH AS VASES, ON THIS APPARATUS.



TO PREVENT ELECTRIC SHOCK DO NOT REMOVE TOP OR BOTTOM COVERS. NO USER SERVICEABLE PARTS INSIDE. REFER SERVICING TO QUALIFIED SERVICE PERSONNEL.



À PRÉVENIR LE CHOC ÉLECTRIQUE N'ENLEVEZ PAS LES COUVERCLES. IL N'Y A PAS DES PARTIES SERVICEABLE À L'INTÉRIEUR. TOUS REPARATIONS DOIT ÊTRE FAIRE PAR PERSONNEL QUALIFIÉ SEULEMENT.



TO COMPLETELY DISCONNECT THIS EQUIPMENT FROM THE AC MAINS, DISCONNECT THE POWER SUPPLY CORD PLUG FROM THE AC RECEPTACLE. THE MAINS PLUG OF THE POWER SUPPLY CORD SHALL REMAIN READILY OPERABLE.



WATCH FOR THESE SYMBOLS:

The lightning bolt triangle is used to alert the user to the risk of electric shock.



The exclamation point triangle is used to alert the user to important operating or maintenance instructions.



IMPORTANT

Commercial Audio Series mixer-amplifiers require Class 2 output wiring.



CAUTION
RISK OF ELECTRIC SHOCK
DO NOT OPEN

AVIS
RISQUE DE CHOC ÉLECTRIQUE
N'OUVREZ PAS



MAGNETIC FIELD

CAUTION! Do not locate sensitive high-gain equipment such as preamplifiers or tape decks directly above or below the unit. Because this amplifier has a high power density, it has a strong magnetic field which can induce hum into unshielded devices that are located nearby. The field is strongest just above and below the unit.

If an equipment rack is used, we recommend locating the amplifier(s) in the bottom of the rack and the preamplifier or other sensitive equipment at the top.

FCC COMPLIANCE NOTICE

This device complies with part 15 of the FCC rules. Operation is subject to the following two conditions: (1) This device may not cause harmful interference, and (2) this device must accept any interference received, including interference that may cause undesired operation.

CAUTION: Changes or modifications not expressly approved by the party responsible for compliance could void the user's authority to operate the equipment.

NOTE: This equipment has been tested and found to comply with the limits for a Class B digital device, pursuant to part 15 of the FCC Rules. These limits are designed to provide reasonable protection against harmful interference in a residential installation. This equipment generates, uses, and can radiate radio frequency energy and, if not installed and used in accordance with the instruction manual, may cause harmful interference to radio communications. However, there is no guarantee that interference will not occur in a particular installation. If this equipment does cause harmful interference to radio or television reception, which can be determined by turning the equipment off and on, the user is encouraged to try to correct the interference by one or more of the following measures:

- Reorient or relocate the receiving antenna.
- Increase the separation between the equipment and receiver.
- Connect the equipment into an outlet on a circuit different from that to which the receiver is connected.
- Consult the dealer or an experienced radio/TV technician for help.

Crown International, Inc.

DECLARATION of CONFORMITY

Issued By: Crown International, Inc.
1718 W. Mishawaka Road
Elkhart, Indiana 46517 U.S.A.

FOR COMPLIANCE QUESTIONS ONLY: Sue Whitfield
574-294-8289
swhitfield@crowintl.com

European Representative's Name and Address:

Nick Owen
35, Bassets Field
Thornhill
Cardiff, South Glamorgan
CF14 9UG United Kingdom

Equipment Type: Commercial Audio Mixer-Amplifiers
Family Name: Mixer-Amplifiers
Model Names: 180MA, 280MA, 1160MA

EMC Standards:

- EN 55103-1:1997** Electromagnetic Compatibility - Product Family Standard for Audio, Video, Audio-Visual and Entertainment Lighting Control Apparatus for Professional Use, Part 1: Emissions
- EN 55103-1:1997** Magnetic Field Emissions-Annex A @ 10 cm and 1 M
- EN 61000-3-2:2001** Limits for Harmonic Current Emissions (equipment input current 16A per phase)
- EN 61000-3-3:2002** Limitation of Voltage Fluctuations and Flicker in Low-Voltage Supply Systems Rated Current 16A
- EN 55022:2003** Limits and Methods of Measurement of Radio Disturbance Characteristics of ITE: Radiated, Class B Limits; Conducted, Class B
- EN 55103-2:1997** Electromagnetic Compatibility - Product Family Standard for Audio, Video, Audio-Visual and Entertainment Lighting Control Apparatus for Professional Use, Part 2: Immunity
- EN 61000-4-2:2001** Electrostatic Discharge Immunity (Environment E2-Criteria B, 4k V Contact, 8k V Air Discharge)
- EN 61000-4-3:2001** Radiated, Radio-Frequency, Electromagnetic Immunity (Environment E2, Criteria A)
- EN 61000-4-4:2001** Electrical Fast Transient/Burst Immunity (Criteria B)
- EN 61000-4-5:2001** Surge Immunity (Criteria B)
- EN 61000-4-6:2003** Immunity to Conducted Disturbances Induced by Radio-Frequency Fields (Criteria A)
- EN 61000-4-11:2001** Voltage Dips, Short Interruptions and Voltage Variation

Safety Standard:

- IEC 60065: 2002 7th Ed.** Safety Requirements - Audio Video and Similar Electronic Apparatus
- CAN/CSA-E60065-03 7th Ed.** Audio, Video and Similar Electronic Apparatus-Safety Requirements
- UL 60065 7th Ed.** Audio /Video and Musical Instrument Apparatus for Household, Commercial and Similar General Use.

I certify that the product identified above conforms to the requirements of the EMC Council Directive 89/336/EEC as amended by 92/31/EEC, and the Low Voltage Directive 73/23/EES as amended by 93/68/EEC.

Signed

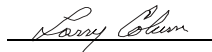

Larry Coburn

Title: Senior Vice President of Manufacturing

Date of Issue: Nov. 1, 2004

Table of Contents

Important Safety Instructions	2	2.12 Powering Up.....	12
Declaration of Conformity	3	2.13 Included Accessories.....	12
1 Welcome	5	2.14 Optional Accessories.....	12
1.1 Features	5	2.15 Block Diagram.....	13
1.2 Front Panel Controls and Indicators	6	3 Troubleshooting	14
1.3 Back Panel Controls and Connectors.....	7	4 Specifications	15
2 Setup	8	5 Service	16
2.1 Installation.....	8	5.1 Worldwide Service	16
2.2 How to Attach Rack Ears.....	8	5.2 US and Canada Service	16
2.3 Choose Input Wire and Connectors	9	5.2.1 Service at a US or Canada Service Center	16
2.4 Choose Output Wire and Connectors	9	5.2.2 Factory Service	16
2.5 Wire Your System	10	5.2.3 Factory Service Shipping Instructions	16
2.6 Input Routing.....	11	5.2.4 Packing Instructions	16
2.7 Phantom Power	11	5.2.5 Estimate Approval.....	16
2.8 Priority Muting	11	5.2.6 Payment of Non-Warranty Repairs.....	16
2.9 Link In/Out Switches.....	11	6 Warranty	17
2.10 Remote Volume Control.....	12	Crown Factory Service Information Form	19
2.11 Four-Tone Generator.....	12		

180MA *1 kHz
Power

Minimum guaranteed power
into 4 ohms or 70V/100V output **80W**

*1 kHz Power: refers to maximum power in watts at
1 kHz with 0.5% THD.



280MA *1 kHz
Power

Minimum guaranteed power
per channel into 4 ohms or
70V/100V output **80W**

*1 kHz Power: refers to maximum power in watts at
1 kHz with 0.5% THD.

1 Welcome

The Crown® 180MA, 280MA and 1160MA are high-value mixer-amplifiers for commercial and industrial audio. They provide 4-ohm and constant-voltage outputs (70V and 100V). The mixer-amps are part of Crown's Commercial Audio Series, which also includes mixers and power amplifiers. These low-cost units provide all necessary features in a simple building-block format.

1.1 Features

- 4 to 8 inputs, 1 to 2 amplifier output channels
- Ideal for commercial and industrial use
- Expandable by adding Crown Commercial Audio mixers or Commercial Audio power amplifiers (when available)
- Balanced Phoenix-type mic/line inputs; touch-protected screw-terminal speaker outputs
- Independent Bass and Treble controls on each input

- Any input can be sent to any output
- Built-in four-tone generator
- Priority muting
- Advanced protection system includes output current limiting, DC protection, circuit breaker/fuse, and thermal protection. Details available online at www.crownaudio.com.
- Three-Year, No-Fault, Fully Transferable Warranty completely protects your investment and guarantees its specifications

1160MA *1 kHz
Power

Minimum guaranteed power
into 4 ohms or 70V/100V output **160W**

*1 kHz Power: refers to maximum power in watts at
1 kHz with 0.5% THD.

1 Welcome

1.2 Front Panel Controls and Indicators

A. Input Signal Presence Indicator

Green LED, one for each input channel, illuminates when input signal exceeds -24 dBu (line) or -70 dBu (mic).

B. Input Volume Controls

Microphone/line, four in 180MA and 1160MA, eight in 280MA. Detented potentiometers with knobs.

C. Output Volume Controls

One per output channel. Detented potentiometer with knob.

D. Output Signal Presence Indicator

Green LED, one for each output channel, illuminates when output signal level exceeds 100 mV (45 dB below full power) from the 4-ohm tap. Does not respond to signals from the AMP INPUT connector.

E. Clip Indicator

Red LED, one per output channel, illuminates at threshold of audible distortion. Does not respond to signals from the AMP INPUT connector.

F. Power Indicator

Blue LED indicates power on.

G, H. Tone Controls

Bass and Treble non-detented potentiometers on each input channel. Bass ± 10 dB at 100 Hz, Treble ± 10 dB at 10 kHz.

I. Power Switch

Pushbutton on-off switch. The power switch does not affect the 24V DC auxiliary power input (letter "K" on next page).

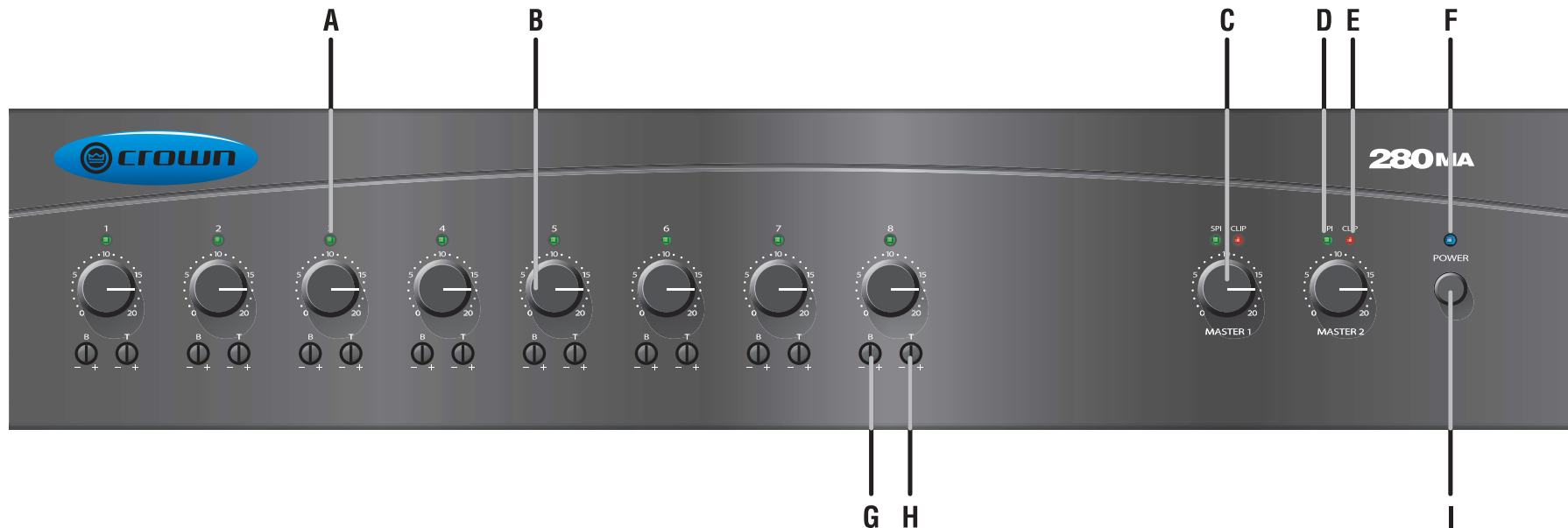

Figure 1.1 Front Panel Controls and Indicators

1 Welcome

1.3 Back Panel Controls and Connectors

J. Reset Switch

Resets the circuit breaker that protects the power supply. 220/230/240V units have a fuse instead.

K. Auxiliary Power Input

2-position terminal strip for 24 VDC ($\pm 10\%$) backup power. Accepts up to 10 AWG terminal forks. NOTE: To prevent a spark when attaching a battery, have unit turned on and connected to the mains supply.



L. Amplifier Outputs Connectors

One per channel, 4-position terminal strip with COM (Common), 4 ohms, 70V and 100V terminals. Accepts up to 14 AWG terminal forks. Non-touch cover included.

M. Amp Config Switch

A DIP switch with two functions:

1. Assigns one of the inputs as the priority input for each output, thereby temporarily muting the remaining inputs. Muting is activated by contact closure.

2. Global enable switch for phantom power. Does not affect RCA inputs. Default position is off.

N. Input Routing Switch (280MA only)

DIP switches that assign each input signal to each output. Two switches per input.

O. Link In/Out Switch

Slide switch, one per channel. With the Link Switch IN, any signal applied to the Amp Input connector will be mixed with the input signal(s). With the Link Switch OUT, only the signal from the Amp Input Connector will appear at the amplifier output.

P. Mic/Line Input Connector

3-pin Phoenix-type, balanced, one per input channel.

Q. Mic/line Switch

Selects mic-level or line-level input signals. One switch for each balanced input.

R. Dual RCA Input Connector

For stereo music signals, unbalanced, summed together,

two connectors per input channel. If required, both the mic/line and RCA inputs may be used at the same time. The mic/line gain switch does not affect the RCA gain, which is fixed relative to mic/line. The mic/line and RCA signals are mixed. Note: Other equipment connected to the RCA jacks should be connected to the same AC power source as the mixer-amp to avoid hum.

S. AC Power Inlet

Detachable IEC.

T. Priority Connector

3-pin Phoenix-type connector allows Input 1 or Input 5 (280MA only) to mute other input signals by contact closure.

U. Output VCA Connector

4-pin Phoenix-type connector for one (180MA) or two (280MA) VCA control lines of +10 VDC and ground. Compatible with Crown 1-VCAP and 4-VCAP modules.

V. Amp Input Connector

3-pin Phoenix-type, high-impedance balanced, one per amplifier channel. Used to link an additional mixer to the

mixer-amplifier. Or used to connect an external processor (see Section 2.9).

W. Line Out Connector

One 3-pin balanced Phoenix-type connector per output channel. Post master, pre-VCA. Level controlled by master volume control.

X. Tone Generator Connector

5-pin Phoenix-type connector. Tones include Pre-Announce Chime, Bell, Alert Tone, and Evacuate Tone. All tones are activated by contact closures on the connector.

Y. Tone Level

One potentiometer per output channel sets the volume of the tones. Tone level is not affected by output volume controls or VCAs.

The Pre-Announce Chime is a special case. It is mixed with Channel-1 signals, so its level will be affected by the master volume control and VCAs.

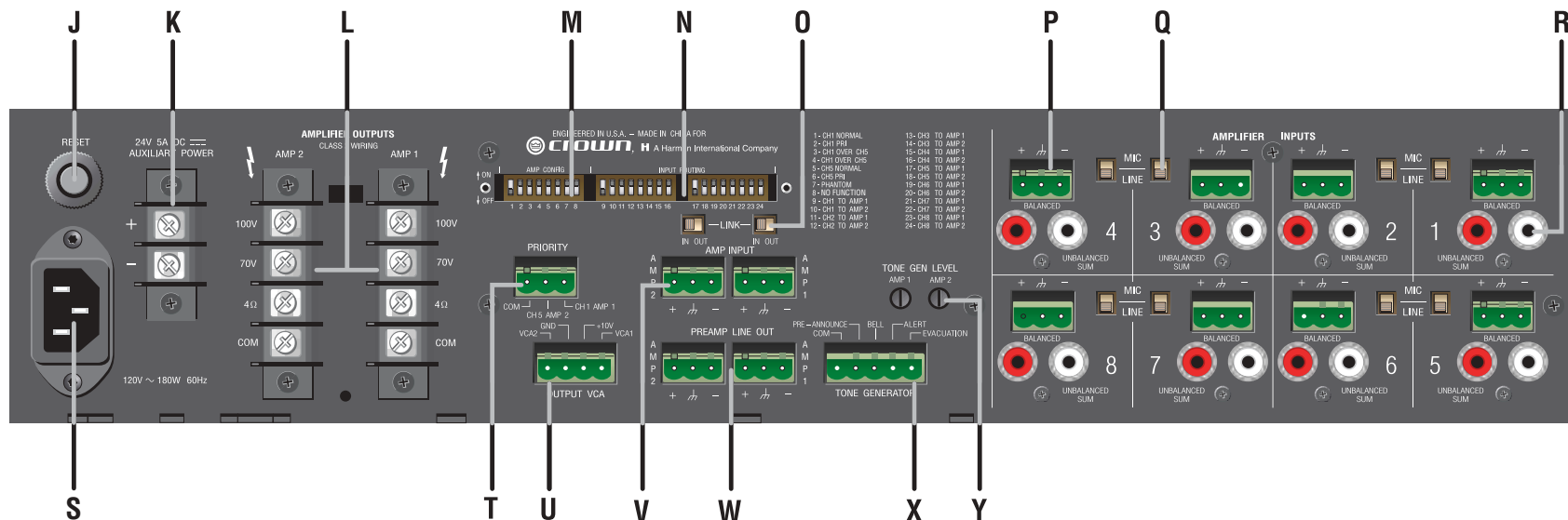

Figure 1.2 Back Panel Controls and Connectors (280MA shown)

2 Setup

2.1 Installation

CAUTION: Before you begin, make sure your mixer-amplifier is disconnected from the power source, with the power switch in the "off" position and all level controls turned completely down (counterclockwise).

Use a standard 19-inch (48.3 cm) equipment rack (EIA RS-310B). See Figure 2.1 for amplifier dimensions.

You may also stack mixer-amps without using a cabinet, or you may place a single mixer-amp on a surface with 12 inches of air space around the unit for convection cooling.

NOTE: When transporting in a rack, mixer-amps should be supported at the front and back.

When using an equipment rack, do not mount units directly on top of each other. Allow 2 U between units for convection cooling. The side walls of the rack should be a minimum of two inches (5.1 cm) away from the amplifier sides, and the back of the rack should be a minimum of four inches (10.2 cm) from the amplifier back panel.

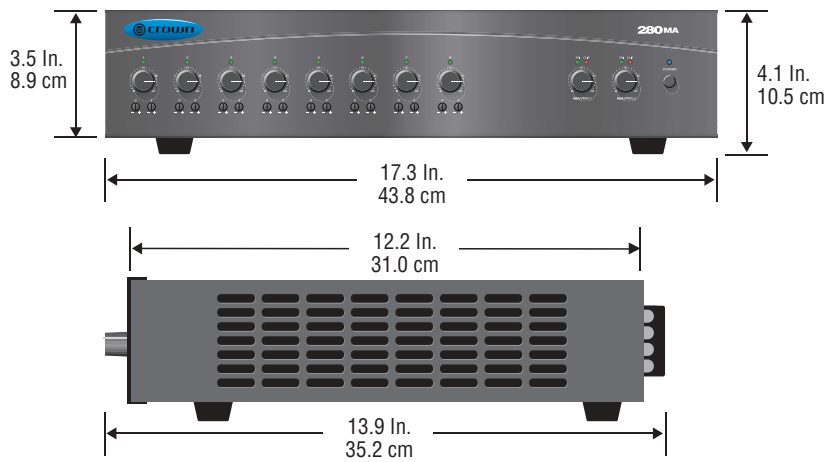

Figure 2.1 Dimensions

2.2 How to Attach Rack Ears

1. Locate the two rack ears and two rack-ear screws supplied.
2. See Figure 2.2. Remove the two screws from each side of the chassis near the front.
3. Place a rack ear flush with the right front of the chassis.
4. Insert a screw that you removed into the bottom hole of the rack ear and chassis. Screw it in.
5. Insert a screw that you removed into the center hole of the rack ear and chassis. Screw it in.
6. Insert one of the supplied screws into the top hole of the rack ear and chassis. Screw it in.
7. Repeat steps 3-6 for the left side of the chassis.

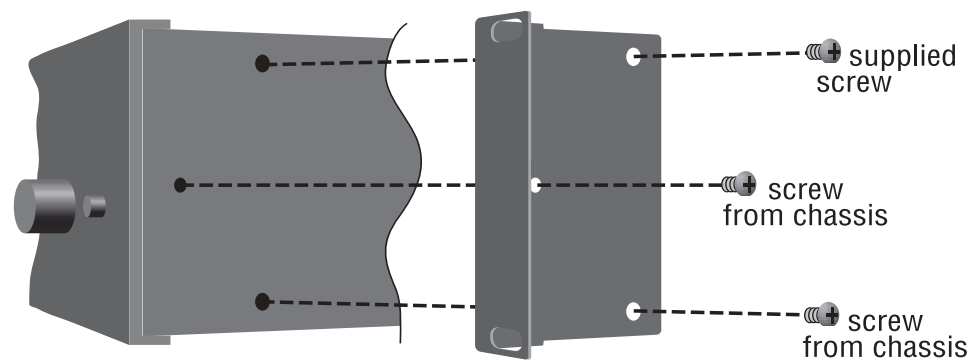

Figure 2.2 How to Connect Rack Ears

2 Setup

2.3 Choose Input Wire and Connectors

Crown recommends using pre-built or professionally wired balanced line (two-conductor plus shield), 22-24 gauge cables and connectors. You should use 3-pin Phoenix-type cable ends at the amplifier inputs. Unbalanced line may also be used but may result in noise over long cable runs.

Figure 2.3 shows connector pin assignments for balanced wiring, and Figure 2.4 shows connector pin assignments for unbalanced wiring. The RCA input connectors can also be used for unbalanced inputs.

2.4 Choose Output Wire and Connectors

For the amplifier output connectors, Crown recommends using pre-built or professionally wired, high-quality, two-conductor, heavy gauge speaker wire and connectors. You may use crimp-on spade lugs for your output connectors (Figure 2.5). To prevent the possibility of short-circuits, wrap or otherwise insulate exposed loudspeaker cable connectors. Cover the output connections with the supplied non-touch cover.

Using the guidelines below, select the appropriate size of wire based on the distance from amplifier to speaker. The wire sizes apply to the 4-ohm tap.

Distance	Wire Size
up to 25 ft.	16 AWG
26-40 ft.	14 AWG
41-60 ft.	12 AWG
61-100 ft.	10 AWG
101-150 ft.	8 AWG
151-250 ft.	6 AWG



NOTE: Custom wiring should only be performed by qualified personnel. Class 2 wiring is required.



CAUTION: Never use shielded cable for output power wiring.

Use 2-conductor shielded cable and 3-pin Phoenix-type connectors for Line Output wiring (Figure 2.6)

BALANCED LINE

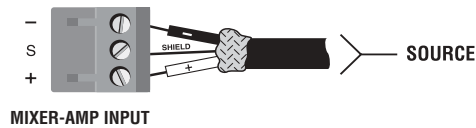

Figure 2.3 Balanced Input Connector Wiring

UNBALANCED LINE

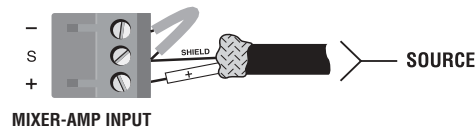

Figure 2.4 Unbalanced Input Connector Wiring

BALANCED LINE



OUTPUT

UNBALANCED LINE



OUTPUT

(This connection reduces the signal level by 6 dB.)

Figure 2.6 Line Out Wiring. Top: Balanced. Bottom: Unbalanced.

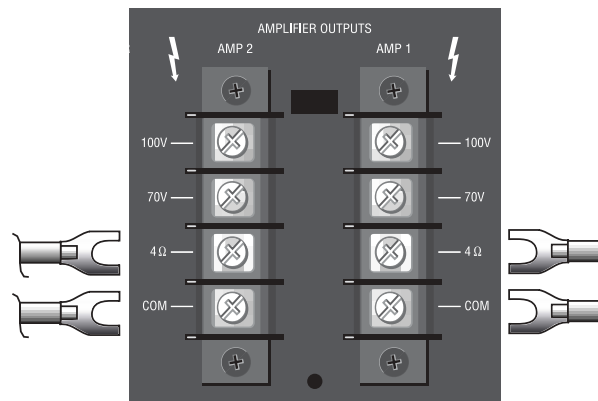

Figure 2.5 Two Amplifier Output Connectors on 280MA Back Panel (One Connector in 180MA and 1160MA)

2 Setup

2.5 Wire Your System

Typical input and output wiring is shown in Figure 2.7

INPUTS: Connect microphones or balanced line-level sources to mixer-amplifier balanced inputs. Set Mic/Line switches accordingly. Connect unbalanced line-level signals to RCA input connectors.

OUTPUTS: Maintain proper polarity (+/-) on output connectors.

For each amplifier channel, connect the Amplifier Output screw terminals to the loudspeaker loads. Use terminals marked COM and 4 OHMS for a 4-ohm loudspeaker load, or use terminals marked COM and 70V or 100V for constant-voltage loudspeaker loads.

Connect the COM terminal to speaker negative (-) lead; connect one of the other terminals to speaker positive (+) lead.

For more application drawings, see the enclosed *Commercial Audio Mixer-Amplifier Quick-Start Guide*.

NOTE: Crown provides a reference of wiring pin assignments for commonly used connector types in the *Crown Amplifier Application Guide* available at www.crownaudio.com.

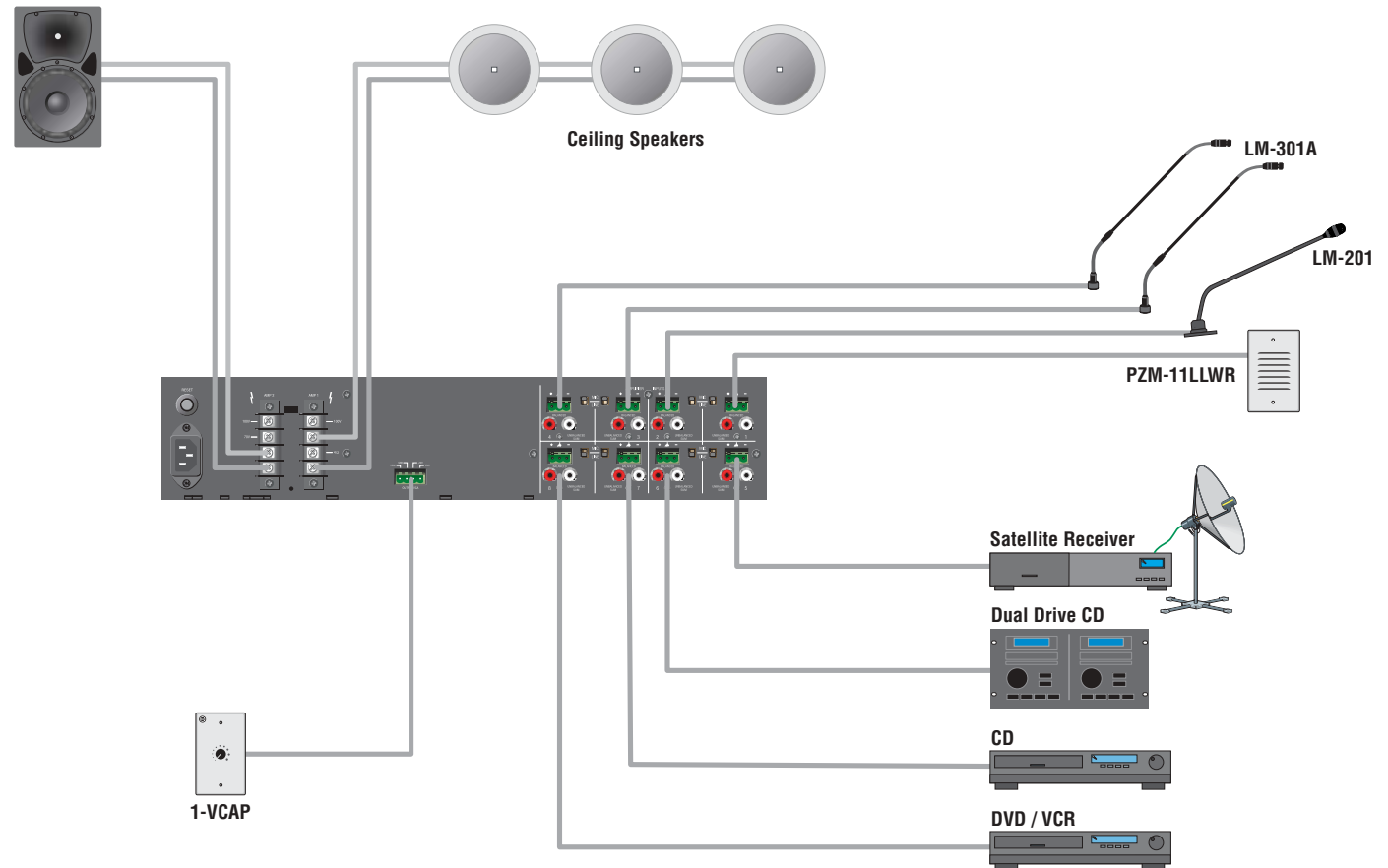

Figure 2.7 Input and Output Wiring

2.6 Input Routing

In the 280MA, any input can be assigned to Amp 1, Amp 2 or both. The two DIP switches labeled INPUT ROUTING are used (Figure 2.8). Follow the settings printed on the back panel next to the INPUT ROUTING switch. For example, to send input Channel 3 to Amp 1 and Amp 2, turn on DIP switches 13 and 14.

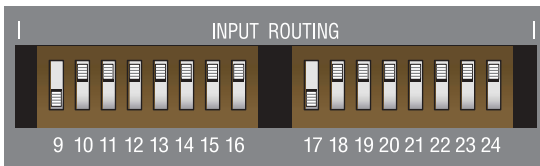

Figure 2.8 Input Routing DIP Switches

2.7 Phantom Power

To turn on phantom power on all mic inputs, turn on the switch number 7 in the AMP CONFIG DIP switch.

2.8 Priority Muting

A back-panel AMP CONFIG DIP switch (Figure 2.9) can assign Input Ch. 1 or Input Ch. 5 as the priority input for each amplifier output, which temporarily mutes the remaining inputs. Muting is activated by contact closures.

For example, suppose you configured Channel 1 as the priority input. Mic 1 is plugged into Channel 1. A press-to-talk switch in Mic 1 is wired to the Priority connector in the mixer-amplifier. When you press the mic switch, all other signals are muted so you can make an announcement on Mic 1.

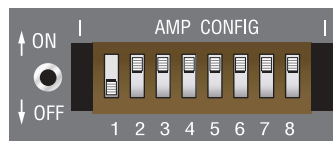

Figure 2.9 AMP CONFIG DIP Switch

One DIP-switch selection enables Channel 1 as the priority input, which mutes all other inputs to Amp 1. In the 280MA only, another DIP switch selection enables Channel 5 as the priority input, which mutes all other inputs to Amp 2. In the 280MA only, another set of DIP switches enable Channel 1 as the priority input into both Amp 1 and Amp 2, effectively muting any input.

To set the mixer-amplifier for normal mode with no priority:

Set the AMP CONFIG DIP switch as follows:

- 1 ON
- 2 OFF
- 3 OFF
- 4 OFF
- 5 ON
- 6 OFF

To give priority to the Channel-1 input in Amp 1 only:

Set the AMP CONFIG DIP switch as follows:

- 1 OFF
- 2 ON
- 3 OFF
- 4 OFF

Also, wire a SPST switch to the PRIORITY connector between COM and CH 1 AMP 1. Close the switch when you want the Channel-1 input to mute all other inputs feeding Amp 1.

To give priority to the Channel-5 input in Amp 2 only:

Set the AMP CONFIG DIP switch as follows:

- 5 OFF
- 6 ON

Also, wire a SPST switch to the PRIORITY connector between COM and CH 5 AMP 2. Close the switch when you want the Channel-5 input to mute all other inputs feeding Amp 2.

To give priority to the Channel-1 input in Amp 1 and Amp 2:

Set the AMP CONFIG DIP switch as follows:

- 1 OFF
- 2 ON
- 3 ON
- 4 ON

Also, wire a SPST switch to the PRIORITY connector between COM and CH1 AMP 1. Close the switch when you want the Channel-1 input to mute all other inputs feeding Amp 1 and Amp 2.

Note: The routing configuration is extremely versatile. Many configurations for additional applications not highlighted in this document can be created by examining the signal flow in the block diagram on page 13.

2.9 Link In/Out Switches

These switches (Figure 2.10) affect which signals are heard when another mixer is wired to the mixer-amplifier. One switch is included per amplifier channel.

IN: Any signal applied to the AMP INPUT connector will be mixed with the input signal(s).

OUT: Only the signal from the AMP INPUT connector will appear at the amplifier output.

How to link another mixer to your mixer-amplifier:

Connect the extra mixer's LINE OUT connector to the mixer-amplifier's AMP INPUT connector. Set the Link switch to IN.

How to set up Music-On-Hold output:

Connect mixer-amp LINE OUT to Music-On-Hold input on telephone system interface/PBX. Set the LINK SWITCH to IN.

How to set up a processing loop:

Connect mixer-amp LINE OUT to processor input. Connect processor output to mixer-amp AMP INPUT connector. Set the Link switch to OUT.

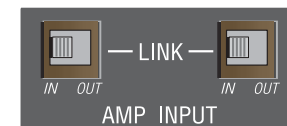

Figure 2.10 Link In/Out Switches

2 Setup

2.10 Remote Volume Control

You can control the volume of each amplifier channel remotely. To do so, locate the OUTPUT VCA connector on the back panel. Insert a 4-pin Phoenix-type cable connector into the OUTPUT VCA connector. Wire a Crown 1-VCAP or 4-VCAP level control to the Phoenix-type cable connector terminals as shown in Figure 2.11.

1-VCAP controls one channel; 4-VCAP controls up to four channels.

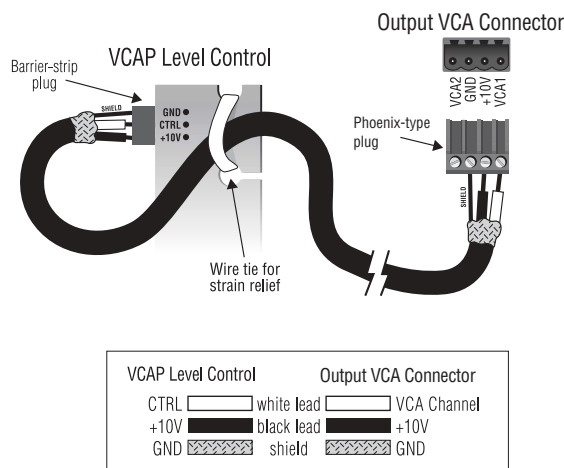

Figure 2.11 Wiring a 1-VCAP or 4-VCAP Level Control to the Output VCA Connector

2.11 Four-Tone Generator

Your mixer-amplifier can generate tones. The factory-preset tones include Pre-Announce Chime, Bell, Alert Tone, and Evacuate Tone. All tones are continuous except for Pre-Announce Chime. All tones are activated by contact closures on the back panel. The Bell, Alert, and Evacuation tones do not pass through the pre-amp outputs.

Tone levels (except for Pre-Announce Chime) are controlled by one trimpot for each amplifier output. Tone levels are not affected by the master level control. Tones mute all signals except for priority signals from Ch.1 and Ch.5. When Ch. 1 or Ch. 5 mutes other signals, the tone and voice signals are mixed.

If you want to generate a tone, locate the TONE GENERATOR connector on the back panel (Figure 2.12). Plug a 5-pin Phoenix-type cable connector into that chassis connector. To activate the Pre-Announce Chime, wire a SPST switch across COM and PRE-ANNOUNCE in the Phoenix-type cable connector. Close the switch when you want the Chime tone to sound. Other tones work in a similar way. Set the TONE GEN LEVEL potentiometer(s) for the desired tone volume.

For example, you might put a magnetic contact closure switch in a door, and wire it to the COM and PRE-ANNOUNCE pins. When the door opens, the switch closes and the chime is activated.

The Pre-Announce Chime is mixed with Ch. 1 signals only. Its output level is not affected by the Tone Gen Level controls.

Note: The Pre-Announce Chime works only on input Ch.1, not input Ch. 5.

2.12 Powering Up

1. Turn off any equipment connected to the Line Out connectors.
2. Plug the amplifier's power cord into a 3-wire grounded AC outlet.
3. Turn down the input volume controls.
4. Turn down the master volume control.
5. Turn on the Power switch. The Power indicator should glow.
6. Turn the input volume controls in use about 3/4 up.
7. Turn up the master volume control(s) until the desired loudness or power level is achieved.
8. Touch up the input levels as needed for equal loudness from each microphone.
9. Turn on any equipment connected to the Line Out connectors.

If you ever need to make any wiring or installation changes, disconnect the power cord.

2.13 Included Accessories

- Power cord
- Detachable rack ears
- Screws for rack ears
- Non-touch cover for output connectors
- Phoenix-type connectors
- Spade lugs

2.14 Optional Accessories

- 1-VCAP remote volume control for one channel
- 4-VCAP remote volume control for four channels

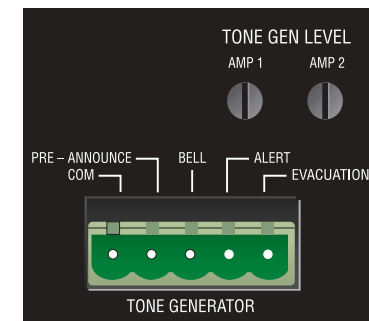
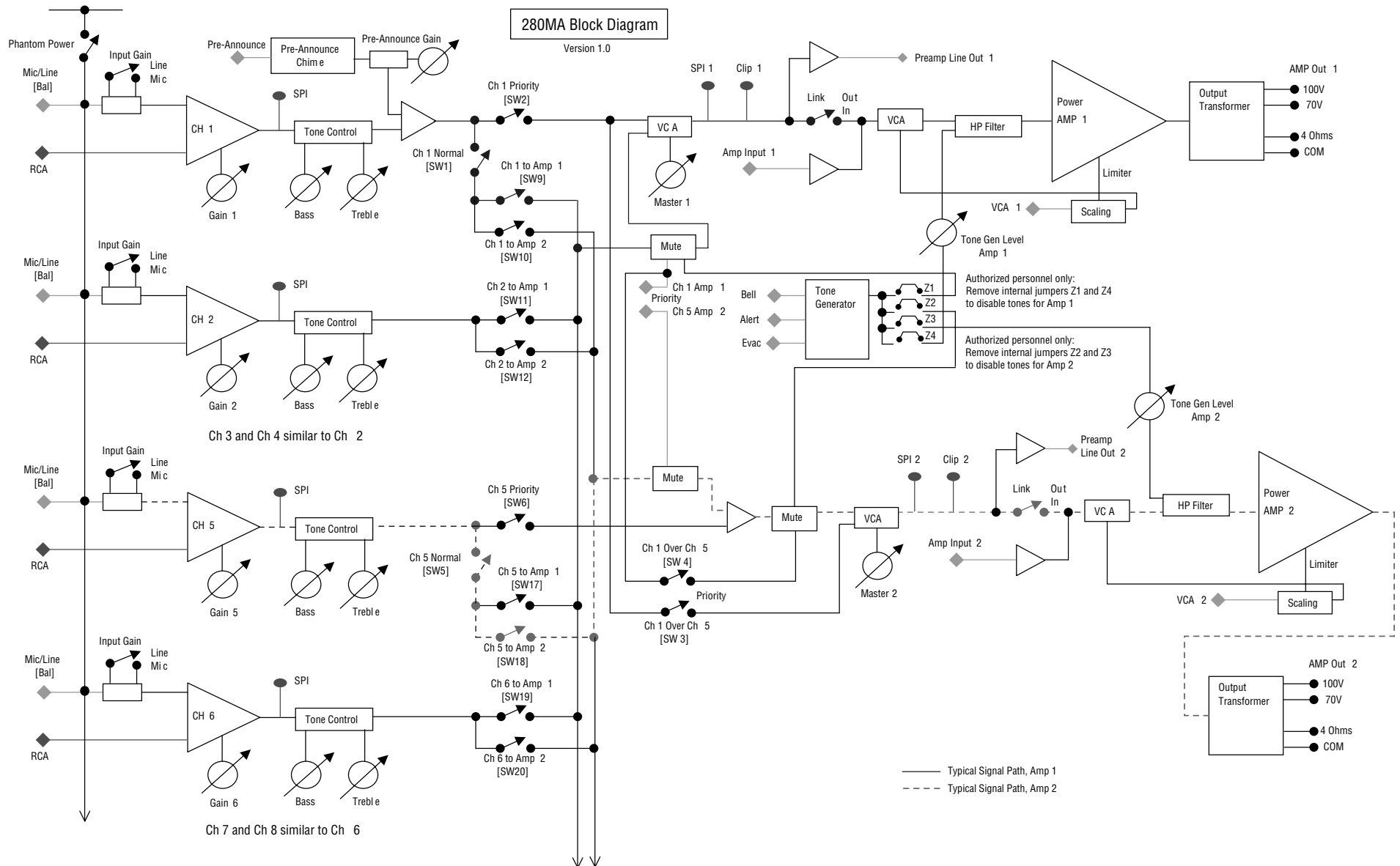



Figure 2.12 Tone Generator Connector

2 Setup

2.15 Block Diagram



3 Troubleshooting



CONDITION: No power to the mixer-amplifier.

POSSIBLE REASON:

- The mixer-amplifier's Power switch is off.
- The mixer-amplifier is not plugged into the power receptacle.
- The mixer-amplifier's high-voltage power supply circuit breaker has tripped, or the fuse has opened on 220/230/240V models. Verify that the AC mains voltage is correct, then press the Reset button on the back panel.
- If the unit is operated from a 24V DC supply, the internal fuse may have opened. (The power switch has no effect on 24V operation.)



CONDITION: Distorted sound.

POSSIBLE REASON:

- Input signal level is too high. Turn down your input volume controls. NOTE: Your mixer-amplifier should never be operated at a level which causes the Clip LEDs to illuminate constantly.
- Master volume level is too high. Turn it down to about 3/4 of maximum level.



CONDITION: No sound.

POSSIBLE REASON:

- The amplifier is in "fault" mode. A Fault status can be triggered when one of the amplifier's protection circuits is activated. First disconnect your speakers from the affected channel(s) one by one to determine if one of the loads is shorted. If an amplifier channel has a thermal fault, there will be no indication on the front panel, but the amp will recover after cooling. If operation does not return to normal after restarting your amp, check the fuse and replace if necessary, or return mixer-amp to Crown or an authorized Crown Service Center for servicing.

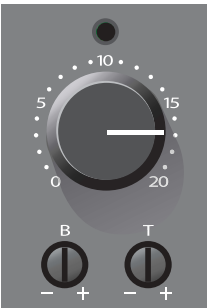

- No input signal.
- Input signal level is very low.

4 Specifications

Minimum Guaranteed Power	180MA	280MA	1160MA
120 VAC, 60 Hz Units, per channel, all channels driven			
1 kHz with 0.5% THD Minimum guaranteed power per channel into 4 ohms or 70V/100V output	80W	80W	160W
Performance	180MA	280MA	1160MA
Number of input channels	4	8	4
Number of power amplifiers	1	2	1
Input Sensitivity (volts RMS) for full output at maximum gain			
Balanced mic inputs	3 mV	3 mV	3 mV
Balanced line inputs	800 mV	800 mV	800 mV
RCA connectors	400 mV	400 mV	400 mV
Frequency Response (at 1 watt from 4-ohm tap, 70 Hz - 19 kHz)	± 1 dB	± 1 dB	± 1 dB
Frequency Response (at line out, 20 Hz to 20 kHz)	± 1 dB	± 1 dB	± 1 dB
Power Bandwidth (at 4-ohm tap, 2 dB below maximum 1 kHz power)	50 Hz to 20 kHz with < 0.5% THD	50 Hz to 20 kHz with < 0.5% THD	50 Hz to 20 kHz with < 0.5% THD
Signal to Noise Ratio (ref. to rated power, master volume at minimum)	85 dB	85 dB	85 dB
Total Harmonic Distortion (THD) at rated power at 1 kHz	< 0.5%	< 0.5%	< 0.5%
DC Output Offset	< ± 5 mV	< ± 5 mV	< ± 5 mV
Input Impedance (nominal)	Mic: 400 ohms, Line: 100 kilohms, RCA: 50 kilohms	Mic: 400 ohms, Line: 100 kilohms, RCA: 50 kilohms	Mic: 400 ohms, Line: 100 kilohms, RCA: 50 kilohms
Crosstalk (all controls at "10")	-70 dB at 1 kHz	-70 dB at 1 kHz	-70 dB at 1 kHz
Line Output Level (nominal)	1V into 10 kilohms	1V into 10 kilohms	1V into 10 kilohms
Phantom Power	15 VDC	15 VDC	15 VDC
AC Line Voltages Available	100V 50/60 Hz 120V 60 Hz 220V 50/60 Hz 230V 50/60 Hz 240V 50/60 Hz	100V 50/60 Hz 120V 60 Hz 220V 50/60 Hz 230V 50/60 Hz 240V 50/60 Hz	100V 50/60 Hz 120V 60 Hz 220V 50/60 Hz 230V 50/60 Hz 240V 50/60 Hz
Operating Temperature/Humidity	0° C to 40° C at 95% relative humidity (non-condensing)	0° C to 40° C at 95% relative humidity (non-condensing)	0° C to 40° C at 95% relative humidity (non-condensing)
Storage Temperature	-20° C to 85° C	-20° C to 85° C	-20° C to 85° C
Construction	180MA	280MA	1160MA
Cooling	Convection cooled	Convection cooled	Convection cooled
Dimensions: Width, Height, Depth (behind mounting surface)	EIA Standard 19" W (EIA RS-310-B) x 3.5" (8.9 cm) H x 14" (35.6cm) D	EIA Standard 19" W (EIA RS-310-B) x 3.5" (8.9 cm) H x 14" (35.6cm) D	EIA Standard 19" W (EIA RS-310-B) x 3.5" (8.9 cm) H x 14" (35.6cm) D
Net Weight, Shipping Weight	21.0 lb. (9.5 kg), 26.0 lb. (11.8 kg)	25.3lb. (11.5kg), 30.3lb. (13.7kg)	25.3lb. (11.5kg), 30.3lb. (13.7kg)

5 Service

Crown amplifiers are quality units that rarely require servicing. Before returning your unit for servicing, please contact Crown Technical Support to verify the need for servicing.

This unit has very sophisticated circuitry which should only be serviced by a fully trained technician. This is one reason why each unit bears the following label:

CAUTION: To prevent electric shock, do not remove covers. No user serviceable parts inside. Refer servicing to a qualified technician.



Complete the Crown Audio Factory Service Information form, in the back of this manual, when returning a Crown product to the factory or authorized service center. The form must be included with your product inside the box or in a packing slip envelope securely attached to the outside of the shipping carton. Do not send this form separately.

5.1 Worldwide Service

Service may be obtained from an authorized service center. (Contact your local Crown/Amcron representative or our office for a list of authorized service centers.) To obtain service, simply present the bill of sale as proof of purchase along with the defective unit to an authorized service center. They will handle the necessary paperwork and repair.

Remember to transport your unit in the original factory pack.

5.2 US and Canada Service

Service may be obtained in one of two ways: from an authorized service center or from the factory. You may choose either. It is important that you have your copy of the bill of sale as your proof of purchase.

5.2.1 Service at a US or Canada Service Center

This method usually saves the most time and effort. Simply present your bill of sale along with the defective unit to an authorized service center to obtain service. They will handle the necessary paperwork and repair. Remem-

ber to transport the unit in the original factory pack. A list of authorized service centers in your area can be obtained from Crown Factory Service, or online from <http://www.crownaudio.com/support/servcent.htm>.

5.2.2 Factory Service

Crown accepts no responsibility for non-serviceable product that is sent to us for factory repair. It is the owner's responsibility to ensure that their product is serviceable prior to sending it to the factory. Serviceable product list is available at <http://crownweb.crownintl.com/crownrma/>. For more information, please contact us direct.

A Service Return Authorization (SRA) is required for product being sent to the factory for repair. An SRA can be completed online at www.crownaudio.com/support/factserv.htm. If you do not have access to the web, please call Crown's Customer Service at 574.294.8200 or 800.342.6939 extension 8205 in North America, Puerto Rico and the Virgin Islands only.

For warranty service, we will pay for ground shipping both ways in the United States. Contact Crown Customer Service to obtain prepaid shipping labels prior to sending the unit. Or, if you prefer, you may prepay the cost of shipping, and Crown will reimburse you. Send copies of the shipping receipts to Crown to receive reimbursement.

Your repaired unit will be returned via UPS ground. Please contact us if other arrangements are required.

5.2.3 Factory Service Shipping Instructions:

1. Service Return Authorization (SRA) is required for product being sent to the factory for service. Please complete the SRA by going to www.crownaudio.com/support/factserv.htm. If you do not have access to our website, call 1.800.342.6939, extension 8205 and we'll create the SRA for you.
2. See packing instructions that follow.
3. Ship product to:
CROWN AUDIO FACTORY SERVICE
1718 W MISHAWKA RD.
ELKHART, IN 46517

4. Use a bold black marker and write the SRA number on three sides of the box.
5. Record the SRA number for future reference. The SRA number can be used to check the repair status.

5.2.4 Packing Instructions

Important: These instructions must be followed. If they are not followed, Crown Audio, Inc. assumes no responsibility for damaged goods and/or accessories that are sent with your unit.

1. Fill out and include the Crown Audio Factory Service Information sheet in the back of this manual.
 2. Do not ship any accessories (manuals, cords, hardware, etc.) with your unit. These items are not needed to service your product. We will not be responsible for these items.
 3. When shipping your Crown product, it is important that it has adequate protection. We recommend you use the original pack material when returning the product for repair (Figure 9.1). If you do not have the original box, please call Crown at 800.342.6939 or 574.294.8210 and order new pack material. (Do not ship your unit in a wood or metal cabinet.)
 4. If you provide your own shipping pack, the minimum recommended requirements for materials are as follows:
 - a. 275 P.S.I. burst test, Double-Wall carton that allows for 2-inch solid Styrofoam on all six sides of unit or 3 inches of plastic bubble wrap on all six sides of unit.
 - b. Securely seal the package with an adequate carton sealing tape.
 - c. Do not use light boxes or "peanuts". Damage caused by poor packaging will not be covered under warranty.
- Enclose the completed Crown Audio Factory Service Information form (or securely attach it to the outside of carton) and re-seal the shipping pack with a sturdy carton sealing tape.

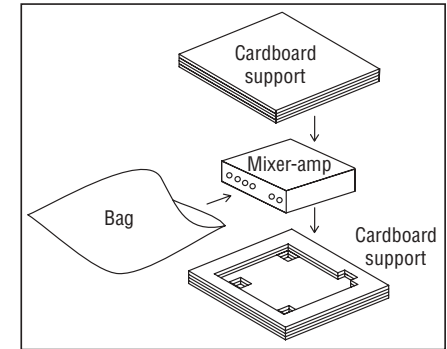

Figure 9.1 Packing.
Put this assembly in carton.

5.2.5 Estimate Approval

Approval of estimate must be given within 90 days after being notified by Crown Audio Inc. Units still in the possession of Crown after 90 days of the estimate will become the property of Crown Audio Inc.

5.2.6 Payment of Non-Warranty Repairs

Payment on out-of-warranty repairs must be received within 90 days of the repair date. Units unclaimed after 90 days become the property of Crown Audio Inc.

If you have any questions, please contact Crown Factory Service.

Crown Factory Service
1718 W. Mishawaka Rd.,
Elkhart, Indiana 46517 U.S.A.

Telephone:
574.294.8200
800.342.6939 (North America,
Puerto Rico, and Virgin Islands only)

Facsimile:
574.294.8301 (Technical Support)
574.294.8124 (Factory Service)

Internet:
<http://www.crownaudio.com>

6 Warranty



SUMMARY OF WARRANTY

Crown International, 1718 West Mishawaka Road, Elkhart, Indiana 46517-4095 U.S.A. warrants to you, the ORIGINAL PURCHASER and ANY SUBSEQUENT OWNER of each NEW Crown product, for a period of three (3) years from the date of purchase by the original purchaser (the "warranty period") that the new Crown product is free of defects in materials and workmanship. We further warrant the new Crown product regardless of the reason for failure, except as excluded in this Warranty.

ITEMS EXCLUDED FROM THIS CROWN WARRANTY

This Crown Warranty is in effect only for failure of a new Crown product which occurred within the Warranty Period. It does not cover any product which has been damaged because of any intentional misuse, accident, negligence, or loss which is covered under any of your insurance contracts. This Crown Warranty also does not extend to the new Crown product if the serial number has been defaced, altered, or removed.

WHAT THE WARRANTOR WILL DO

We will remedy any defect, regardless of the reason for failure (except as excluded), by repair, replacement, or refund. We may not elect refund unless you agree, or unless we are unable to provide replacement, and repair is not practical or cannot be timely made. If a refund is elected, then you must make the defective or malfunctioning product available to us free and clear of all liens or other encumbrances. The refund will be equal to the actual purchase price, not including inter-

UNITED STATES & CANADA

est, insurance, closing costs, and other finance charges less a reasonable depreciation on the product from the date of original purchase. Warranty work can only be performed at our authorized service centers or at the factory. Warranty work for some products can only be performed at our factory. We will remedy the defect and ship the product from the service center or our factory within a reasonable time after receipt of the defective product at our authorized service center or our factory. All expenses in remedying the defect, including surface shipping costs in the United States, will be borne by us. (You must bear the expense of shipping the product between any foreign country and the port of entry in the United States including the return shipment, and all taxes, duties, and other customs fees for such foreign shipments.)

HOW TO OBTAIN WARRANTY SERVICE

You must notify us of your need for warranty service within the warranty period. All components must be shipped in a factory pack, which, if needed, may be obtained from us free of charge. Corrective action will be taken within a reasonable time of the date of receipt of the defective product by us or our authorized service center. If the repairs made by us or our authorized service center are not satisfactory, notify us or our authorized service center immediately.

DISCLAIMER OF CONSEQUENTIAL AND INCIDENTAL DAMAGES

YOU ARE NOT ENTITLED TO RECOVER FROM US ANY INCIDENTAL DAMAGES RESULTING

FROM ANY DEFECT IN THE NEW CROWN PRODUCT. THIS INCLUDES ANY DAMAGE TO ANOTHER PRODUCT OR PRODUCTS RESULTING FROM SUCH A DEFECT. SOME STATES DO NOT ALLOW THE EXCLUSION OR LIMITATIONS OF INCIDENTAL OR CONSEQUENTIAL DAMAGES, SO THE ABOVE LIMITATION OR EXCLUSION MAY NOT APPLY TO YOU.

WARRANTY ALTERATIONS

No person has the authority to enlarge, amend, or modify this Crown Warranty. This Crown Warranty is not extended by the length of time which you are deprived of the use of the new Crown product. Repairs and replacement parts provided under the terms of this Crown Warranty shall carry only the unexpired portion of this Crown Warranty.

DESIGN CHANGES

We reserve the right to change the design of any product from time to time without notice and with no obligation to make corresponding changes in products previously manufactured.

LEGAL REMEDIES OF PURCHASER

THIS CROWN WARRANTY GIVES YOU SPECIFIC LEGAL RIGHTS, YOU MAY ALSO HAVE OTHER RIGHTS WHICH VARY FROM STATE TO STATE. No action to enforce this Crown Warranty shall be commenced after expiration of the warranty period.

THIS STATEMENT OF WARRANTY SUPERSEDES ANY OTHERS CONTAINED IN THIS MANUAL FOR CROWN PRODUCTS. 12/01

6 Warranty



WORLDWIDE EXCEPT USA & CANADA

SUMMARY OF WARRANTY

Crown International, 1718 West Mishawaka Road, Elkhart, Indiana 46517-4095 U.S.A. warrants to you, the ORIGINAL PURCHASER and ANY SUBSEQUENT OWNER of each NEW Crown1 product, for a period of three (3) years from the date of purchase by the original purchaser (the "warranty period") that the new Crown product is free of defects in materials and workmanship, and we further warrant the new Crown product regardless of the reason for failure, except as excluded in this Warranty.

¹ Note: If your unit bears the name "Amcron," please substitute it for the name "Crown" in this warranty.

ITEMS EXCLUDED FROM THIS CROWN-WARRANTY

This Crown Warranty is in effect only for failure of a new Crown product which occurred within the Warranty Period. It does not cover any product which has been damaged because of any intentional misuse, accident, negligence, or loss which is covered under any of your insurance contracts. This Crown Warranty also does not extend to the new Crown product if the serial number has been defaced, altered, or removed.

WHAT THE WARRANTOR WILL DO

We will remedy any defect, regardless of the reason for failure (except as excluded), by repair, replacement, or refund. We may not elect refund unless you agree, or unless we are unable to provide replacement, and repair is not practical or cannot be timely made. If a refund is elected, then you must make the defective or malfunctioning product available to us free and clear of all liens or other encumbrances. The refund will be equal to the actual purchase price, not including interest, insurance, closing costs, and other finance charges less a reasonable depreciation on the product from the date of original purchase. Warranty work can only be performed at our authorized service centers. We will remedy the defect and ship the product from the service center within a reasonable time after receipt of the defective product at our authorized service center.

HOW TO OBTAIN WARRANTY SERVICE

You must notify your local Crown importer of your need for warranty service within the warranty period. All components must be shipped in the original box. Corrective action will be taken within a reasonable time of the date of receipt of the defective product by our authorized service center. If the repairs made by our authorized service center are not satisfactory, notify our authorized service center immediately.

DISCLAIMER OF CONSEQUENTIAL AND INCIDENTAL DAMAGES

YOU ARE NOT ENTITLED TO RECOVER FROM US ANY INCIDENTAL DAMAGES RESULTING FROM ANY DEFECT IN THE NEW CROWN PRODUCT. THIS INCLUDES ANY DAMAGE TO ANOTHER PRODUCT OR PRODUCTS RESULTING FROM SUCH A DEFECT.

WARRANTY ALTERATIONS

No person has the authority to enlarge, amend, or modify this Crown Warranty. This Crown Warranty is not extended by the length of time which you are deprived of the use of the new Crown product. Repairs and replacement parts provided under the terms of this Crown Warranty shall carry only the unexpired portion of this Crown Warranty.

DESIGN CHANGES

We reserve the right to change the design of any product from time to time without notice and with no obligation to make corresponding changes in products previously manufactured.

LEGAL REMEDIES OF PURCHASER

No action to enforce this Crown Warranty shall be commenced after expiration of the warranty period.

THIS STATEMENT OF WARRANTY SUPERSEDES ANY OTHERS CONTAINED IN THIS MANUAL FOR CROWN PRODUCTS. 7/01



Crown Audio Factory Service Information

Shipping Address: Crown Audio Factory Service, 1718 W. Mishawaka Rd., Elkhart, IN 46517

PLEASE PRINT CLEARLY

SRA #: _____ (If sending product to Crown factory service.) Model: _____ Serial Number: _____ Purchase Date: _____

PRODUCT RETURN INFORMATION

Individual or Business Name: _____

Phone #: _____ Fax #: _____ E-Mail: _____

Street Address (please, no P.O. Boxes): _____

City: _____ State/Prov: _____ Postal Code: _____ Country: _____

Nature of problem: _____

Other equipment in your system: _____

If warranty is expired, please provide method of payment. Proof of purchase may be required to validate warranty.

PAYMENT OPTIONS

I have open account payment terms. Purchase order required. PO#: _____ COD

Credit Card (Information below is required; however if you do not want to provide this information at this time, we will contact you when your unit is repaired for the information.)

Credit card information:

Type of credit card: MasterCard Visa American Express Discover

Type of credit card account: Personal/Consumer Business/Corporate

Card # _____ Exp. date: _____ * Card ID #: _____

* Card ID # is located on the back of the card following the credit card #, in the signature area. On American Express, it may be located on the front of the card. This number is required to process the charge to your account. If you do not want to provide it at this time, we will call you to obtain this number when the repair of your unit is complete.

Name on credit card: _____

Billing address of credit card: _____



H A Harman International Company

Free Manuals Download Website

<http://myh66.com>

<http://usermanuals.us>

<http://www.somanuals.com>

<http://www.4manuals.cc>

<http://www.manual-lib.com>

<http://www.404manual.com>

<http://www.luxmanual.com>

<http://aubethermostatmanual.com>

Golf course search by state

<http://golfingnear.com>

Email search by domain

<http://emailbydomain.com>

Auto manuals search

<http://auto.somanuals.com>

TV manuals search

<http://tv.somanuals.com>