

CROWN Boiler Co.

D E S I G N E D T O L E A D

BWC Series

BWC150/225 CONCENTRIC VENTING INSTALLATION INSTRUCTIONS

These instructions must be affixed on or adjacent to the boiler.

Models:

- BWC150
- BWC225

WARNING: Improper installation, adjustment, alteration, service or maintenance can cause property damage, injury, or loss of life. For assistance or additional information, consult a qualified installer, service agency or the gas supplier. This boiler requires a special venting system. Read these instructions carefully before installing.

CROWN Boiler Co.

Manufacturer of Hydronic Heating Products
P.O. Box 14818 3633 I. Street
Philadelphia, PA 19134

Tel: (215) 535-8900 • Fax: (215) 535-9736 • www.crownboiler.com

Table of Contents

A. Concentric Vent System Design	2
B. Concentric Vent Adapter Kit Installation	9
C. Assembly of Crown Concentric Venting and Condensate Drain	11

WARNING

FAILURE TO VENT THIS BOILER IN ACCORDANCE WITH THESE INSTRUCTIONS COULD CAUSE FLUE GAS TO ENTER THE BUILDING RESULTING IN SEVERE PROPERTY DAMAGE, PERSONAL INJURY, OR DEATH:

- * Do not attempt to vent this boiler with galvanized, PVC, or any other vent components not listed in Table 1.6.
- * Do not attempt to mix components from different approved vent systems.
- * Do not obtain combustion air from within the building.
- * Do not install a barometric damper or draft hood on this boiler.

CAUTION

Moisture and ice may form on the surfaces around the vent termination. To prevent deterioration, surfaces should be in good repair (sealed, painted, etc.).

Concentric Venting For BWC150 and BWC225

A. Concentric Vent System Design

In addition to the vent options listed in the installation manual there are two other ways to vent this boiler:

- **Horizontal (“Side Wall”) Concentric Venting** - Vent system exits the building through an outside wall. Concentric venting consists of a “pipe within a pipe”. Flue gas exits the building through the inner pipe and combustion air is drawn into the boiler through the space between the inner and outer pipe.
- **Vertical Concentric Venting** - Vent system exits the building through the roof. Concentric venting consists of a “pipe within a pipe”. Flue gas exits the building through the inner pipe and combustion air is drawn into the boiler through the space between the inner and outer pipe.

These systems are considered “direct vent” because air for combustion is drawn directly from the outdoors into the boiler. A description of these venting options are shown in Tables 1.1 and 1.5. For clarity, the vent options are numbered 3 and 4 for the horizontal options and 8 and 9 for the vertical options. One of the vent option columns in Tables 1.1 or 1.5 must match the planned vent and air intake system exactly. In addition, observe the following guidelines:

- 1) Approved concentric vent systems - The concentric vent system is optional for the BWC150 and BWC225 boilers. Each Crown concentric vent component consists of an inner pipe of polypropylene and the outer pipe of steel. Integral gaskets on each concentric fitting provide a gas tight seal. Concentric pipe sizes are called out in terms of the inner and outer pipe nominal diameters in millimeters. For example, “80/125mm” pipe consists of a 80mm exhaust pipe inside a 125mm diameter outer pipe. A list of all Crown concentric vent components is shown in Table 1.6. Use only one of the approved concentric vent systems shown in Table 1.6.

A concentric vent adapter kit is required to use these boilers with concentric pipe. Part numbers for these kits are:

BWC150 P/N 230550

BWC225 P/N 230555

- 2) Maximum Vent and Air Intake Lengths - The maximum length of the vent air intake piping depends upon the vent option selected and the boiler size. See Table 1.1 or 1.5 for the maximum vent length. In horizontal vent systems, the lengths shown in Table 1.1 are in addition to the vent components which come with the Air Intake Box Kit and one standard radius elbow. For vertical vent systems, the maximum vertical vent lengths shown in Table 1.5 are in addition to the vent components which come with the Air Intake Box Kit and two standard radius elbows. If more elbows are desired, the maximum allowable vent length must be reduced by the amount shown in Table 1.4 for each additional elbow used. Termination fittings are never counted, although the length of the concentric terminal section is counted.

Example:

A 80/125mm concentric vent system is planned for a horizontally vented BWC150 which has the following components:

Standard Radius 90° Elbow
5ft Straight Pipe
Standard Radius 90° Elbow
1-1/2ft Straight Pipe
45° Elbow
Uncut Terminal Section

The Vent Option #3 column in Table 1.1 describes a horizontal direct vent system using 80/125mm concentric vent pipe. From this column, we see that a BWC150 may have a vent length of up to 55ft. The first 90° standard radius elbow is not considered. The length of the terminal section (not including the terminal itself) is approximately 22.1” (1.84ft) installed. From Table 1.4, we see that the equivalent length of the 80/125mm 90° elbow is 8.5ft and that the equivalent length of the 45 degree elbow is 3.0ft. The total equivalent length of the planned venting system is therefore:

5ft (Straight) + 8.5ft (90 Elbow) + 1.5ft (Straight) + 3.0ft (45 Elbow) + 1.84ft (Uncut Terminal Section) = 19.84ft.

Since Table 1.1 shows a maximum allowable vent length of 55ft, the planned vent system length is acceptable.

- 3) Minimum Vent and Air Intake Lengths - Observe the minimum vent lengths shown in Tables 1.1 and 1.5.
- 4) Permitted Terminals for Horizontal Venting:
 - **Vent Option 3** - 80/125mm Concentric Vent Terminal (Crown PN 230531)
 - **Vent Option 4** - 100/150mm Concentric Vent Terminal (Crown PN 230569)
- 5) Horizontal Vent and Air Intake Terminal Location - Observe the following limitations on the vent terminal location (also see Figure 1.3). When locating a concentric terminal, observe the limitations outlined below for “vent terminals”.
 - Vent terminal must be at least 1 foot from any door, window, or gravity inlet into the building.
 - The bottom of terminal must be at least 12” above the normal snow line. In no case should it be less than 12” above grade level.
 - The bottom of the vent terminal must be at least 7 feet above a public walkway.
 - Do not install the vent terminal directly over windows or doors.
 - The bottom of the vent terminal must be at least 3 feet above any forced air inlet located within 10 feet.
 - A clearance of at least 4 feet horizontally must be maintained between the vent terminal and gas meters, electric meters, regulators, and relief equipment. Do not install vent terminal over this equipment.
 - Do not locate the vent terminal under decks or similar structures.
 - Top of vent terminal must be at least 5 feet below eaves, soffits, or overhangs. Maximum depth of overhang is 3 ft.
 - Vent terminal must be at least 6 feet from an inside corner.
 - Under certain conditions, water in the flue gas may condense, and possibly freeze, on objects around the vent terminal including on the structure itself. If these objects are subject to damage by flue gas condensate, they should be moved or protected.
 - If possible, install the vent and air intake terminals on a wall away from the prevailing wind. Reliable operation of this boiler cannot be guaranteed if these terminals are subjected to winds in excess of 40 mph.
 - Terminal must not terminate in areas that might contain combustion air contaminants, such as near swimming pools. See Section IV in the installation manual for more information on possible contaminants.

TABLE 1.1: SUMMARY OF HORIZONTAL VENTING OPTIONS

VENT OPTION #			3	4
CLASSIFICATION USED IN THIS MANUAL			HORIZONTAL CONCENTRIC	HORIZONTAL CONCENTRIC
ILLUSTRATED IN FIGURE			1.2	1.2
VENT PIPE PENETRATION THROUGH STRUCTURE			WALL	WALL
AIR INTAKE PIPE PENETRATION THROUGH STRUCTURE			WALL	WALL
VENT PIPE SIZE			80/125 mm	100/150 mm
AIR INTAKE PIPE SIZE			CONCENTRIC	CONCENTRIC
MAXIMUM LENGTH	VENT	BWC150	55	
		BWC225		55
	INLET	BWC150	55	
		BWC225		55
MINIMUM LENGTH	VENT	BWC150	2	
		BWC225		2
	INLET	BWC150	2	
		BWC225		2
VENT TERMINAL			Crown 230531 CONCENTRIC TERMINAL	Crown 230569 CONCENTRIC TERMINAL
AIR INTAKE TERMINAL				
VENT MATERIAL			CROWN 80/125mm VENT COMPONENTS SHOWN IN TABLE 1.6a	CROWN 100/150mm VENT COMPONENTS SHOWN IN TABLE 1.6b
AIR INTAKE MATERIAL				

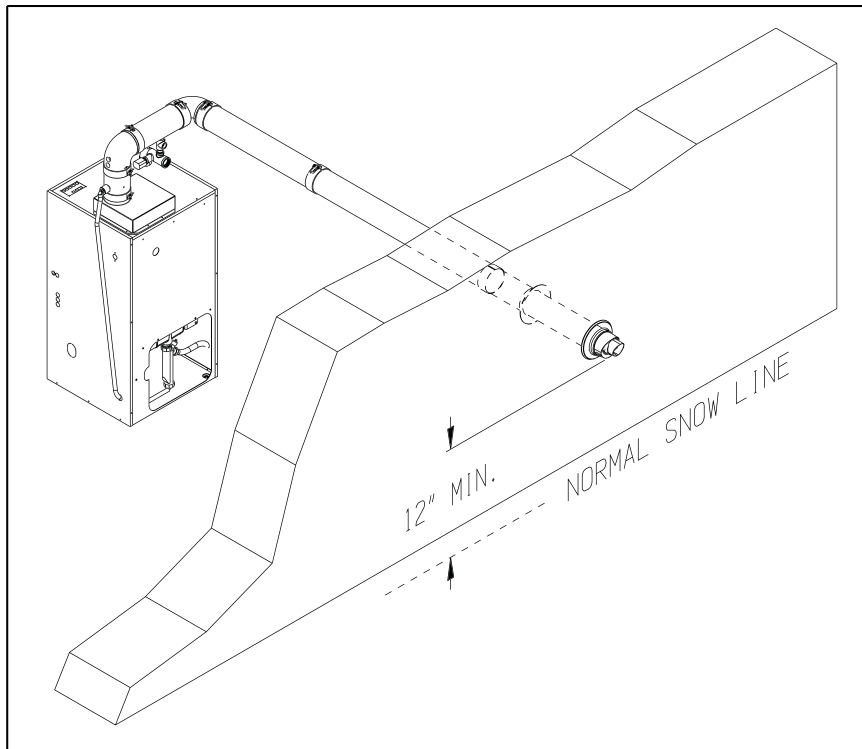

FIGURE 1.2: HORIZONTAL CONCENTRIC VENTING
(VENT OPTION 3,4)

- 6) Permitted Terminals for Vertical Venting -
- **Vent Option 8** - Use Crown PN 230532 with the appropriate flashing (Table 1.6a)
 - **Vent Option 9** - Use Crown PN 230570 with the appropriate flashing (Table 1.6b)
- 7) Vertical Vent Terminal Locations (Vent Options 8,9) - Observe the following limitations on the location of all vertical vent terminals (see Figure 1.7):
- The top of the vent pipe must be at least 2 feet above any object located within 10 feet.
 - The bottom of the air inlet terminal must be at least 12" above the normal snow accumulation that can be expected on the roof. The terminal used in Vent Options 8 & 9 has a fixed distance above the storm collar of 19". If a greater distance is needed to provide the clearance above the snow line, build a chase on the roof and mount the vertical terminal on top of the chase.
- 8) Wall thimbles – Concentric vent has a “zero” clearance to combustibles and therefore does not require the use of wall thimbles.
- 9) Pitch of Horizontal Piping - Pitch all horizontal piping 5/8" per foot so that any condensate which forms in the piping will run towards the boiler:
- 10) Supporting Pipe - Support Crown concentric venting near the female end of each straight section of pipe.
Exception: Vertical runs of concentric pipe in an unused chimney (Figure 1.14) need only be supported at the terminal and at the base of the run.

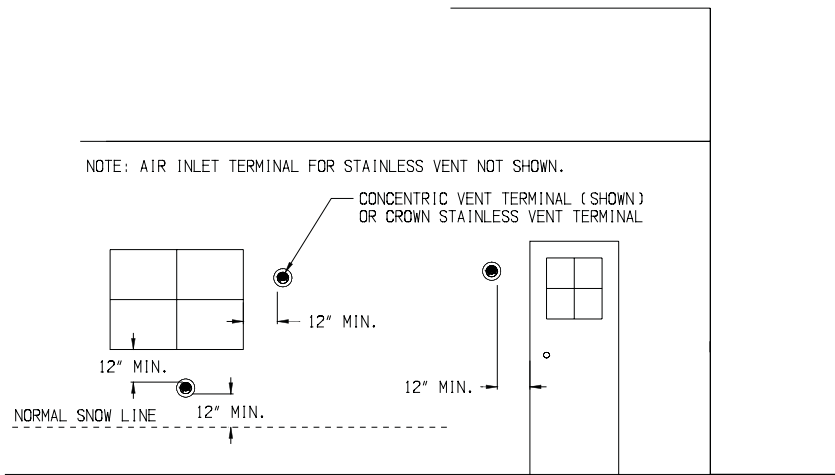

FIGURE 1.3a: LOCATION OF VENT TERMINAL RELATIVE TO WINDOWS, DOORS, GRADE

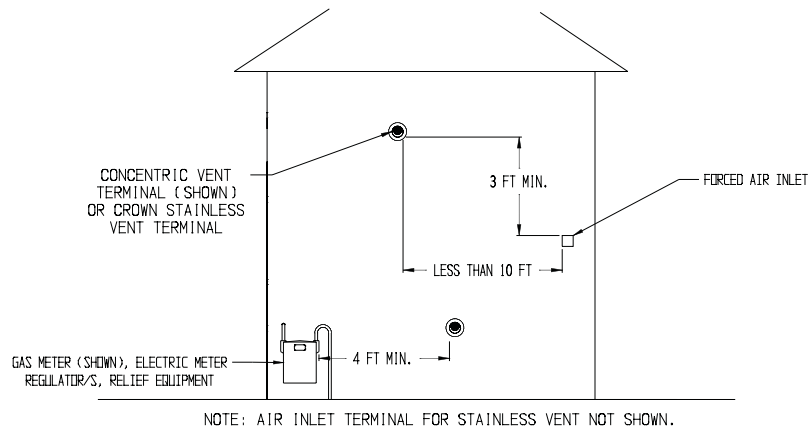

FIGURE 1.3b: LOCATION OF VENT TERMINAL RELATIVE TO METERS AND FORCED AIR INLETS

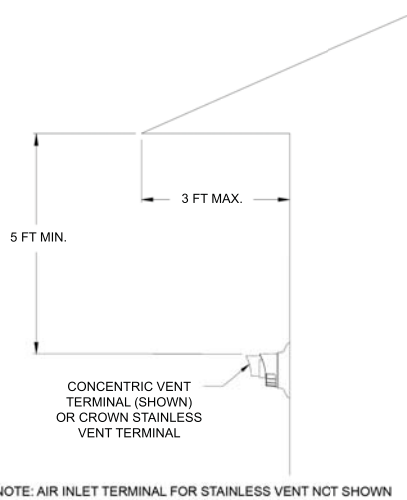

FIGURE 1.3c: POSITIONING VENT TERMINAL UNDER OVERHANGS

TABLE 1.4: VENT/ AIR INTAKE FITTING EQUIVALENT LENGTH

VENT FITTING	EQUIVALENT LENGTH (ft)
80/125mm 90° CONCENTRIC ELBOW	8.5
80/125mm 90° SWEEP CONCENTRIC ELBOW	5.5
80/125mm 45° CONCENTRIC ELBOW	3.0
80/125mm 90° CONCENTRIC SUPPORT ELBOW	8.5
100/150mm 90° SWEEP CONCENTRIC ELBOW	8.0
100/150mm 45° CONCENTRIC ELBOW	3.0
100/150mm 90° CONCENTRIC SUPPORT ELBOW	10.0

TABLE 1.5: SUMMARY OF VERTICAL VENTING OPTIONS

VENT OPTION #			8	9
CLASSIFICATION USED IN THIS MANUAL			VERTICAL CONCENTRIC	VERTICAL CONCENTRIC
ILLUSTRATED IN FIGURE			1.7	1.7
VENT PIPE PENETRATION THROUGH STRUCTURE			ROOF	ROOF
AIR INTAKE PIPE STRUCTURE THROUGH STRUCTURE			ROOF	ROOF
VENT PIPE SIZE			80/125 mm CONCENTRIC	100/150 mm CONCENTRIC
AIR INTAKE PIPE SIZE				
MAXIMUM LENGTH	VENT	BWC150	47	
		BWC225		45
	INLET	BWC150	47	
		BWC225		45
MINIMUM LENGTH	VENT	BWC150	2	
		BWC225		2
	INLET	BWC150	2	
		BWC225		2
VENT TERMINAL			CROWN #230532 CONCENTRIC TERMINAL (TABLE 1.6a)	CROWN #230570 CONCENTRIC TERMINAL (TABLE 1.6b)
AIR INTAKE TERMINAL				
VENT MATERIAL			CROWN 80/125 mm VENT COMPONENTS SHOWN IN TABLE 1.6a	CROWN 100/150 mm VENT COMPONENTS SHOWN IN TABLE 1.6b
AIR INTAKE MATERIAL				

**TABLE 1.6a: CROWN CONCENTRIC 80/125 VENT COMPONENTS
(VENT OPTIONS 3,8)**

CROWN PN	DESCRIPTION	SIZE	USED ON VENT OPTION #	COMMENTS
230527	90 DEGREE EL (STANDARD)	80/125mm	3,8	
230528	90 DEGREE EL (SWEEP)	80/125mm	3,8	
230526	45 DEGREE EL	80/125mm	3,8	
230517	19 1/2" STRAIGHT	80/125mm	3,8	CAN BE CUT
230515	39" STRAIGHT	80/125mm	3,8	CAN BE CUT
230518	39" STRAIGHT	80/125mm	3,8	MAY NOT BE CUT
230519	78" STRAIGHT	80/125mm	3,8	MAY NOT BE CUT
230525	TELESCOPING STRAIGHT	80/125mm	3,8	ADJUSTABLE FROM 12-1/2" TO 16-1/2"
230531	HORIZONTAL TERMINAL	80/125mm	3	
230532	VERTICAL TERMINAL	80/125mm	8	(NOTE #1)
230533	FLAT ROOF FLASHING	80/125mm	8	
230535	SLOPED ROOF FLASHING	80/125mm	8	(NOTE #2)
230530	SUPPORT ELBOW WITH CHIMNEY CHASE BRACKET	80/125mm	8	(NOTE #3)
230536	SUPPORT BAND	80/125mm	3,8	

Table 1.6a Notes:

- 1) Vertical terminal can be used with either of the roof flashings listed beneath it.
- 2) Sloped roof flashing suitable for roof angles between 25 and 45 degrees.
- 3) Used at base of vertical run inside unused masonry chimney.

**TABLE 1.6b: CROWN CONCENTRIC 100/150 VENT COMPONENTS
(VENT OPTIONS 8,9)**

CROWN PN	DESCRIPTION	SIZE	USED ON VENT OPTION #	COMMENTS
230567	90 DEGREE EL (SWEEP)	100/150mm	4,9	
230565	45 DEGREE EL	100/150mm	4,9	
230560	19 1/2" STRAIGHT	100/150mm	4,9	CAN BE CUT
230562	39" STRAIGHT	100/150mm	4,9	CAN BE CUT
230561	39" STRAIGHT	100/150mm	4,9	MAY NOT BE CUT
230563	78" STRAIGHT	100/150mm	4,9	MAY NOT BE CUT
230564	TELESCOPING STRAIGHT	100/150mm	4,9	ADJUSTABLE FROM 12-1/2" TO 17-1/2"
230569	HORIZONTAL TERMINAL	100/150mm	4	
230570	VERTICAL TERMINAL	100/150mm	9	(NOTE #1)
230571	FLAT ROOF FLASHING	100/150mm	9	
230572	SLOPED ROOF FLASHING	100/150mm	9	(NOTE #2)
230568	SUPPORT ELBOW WITH CHIMNEY CHASE BRACKET	100/150mm	9	(NOTE #3)
230573	SUPPORT BAND	100/150mm	4,9	

Table 1.6b Notes:

- 1) Vertical terminal can be used with either of the roof flashings listed beneath it.
- 2) Sloped roof flashing suitable for roof angles between 25 and 45 degrees.
- 3) Used at base of vertical run inside unused masonry chimney.

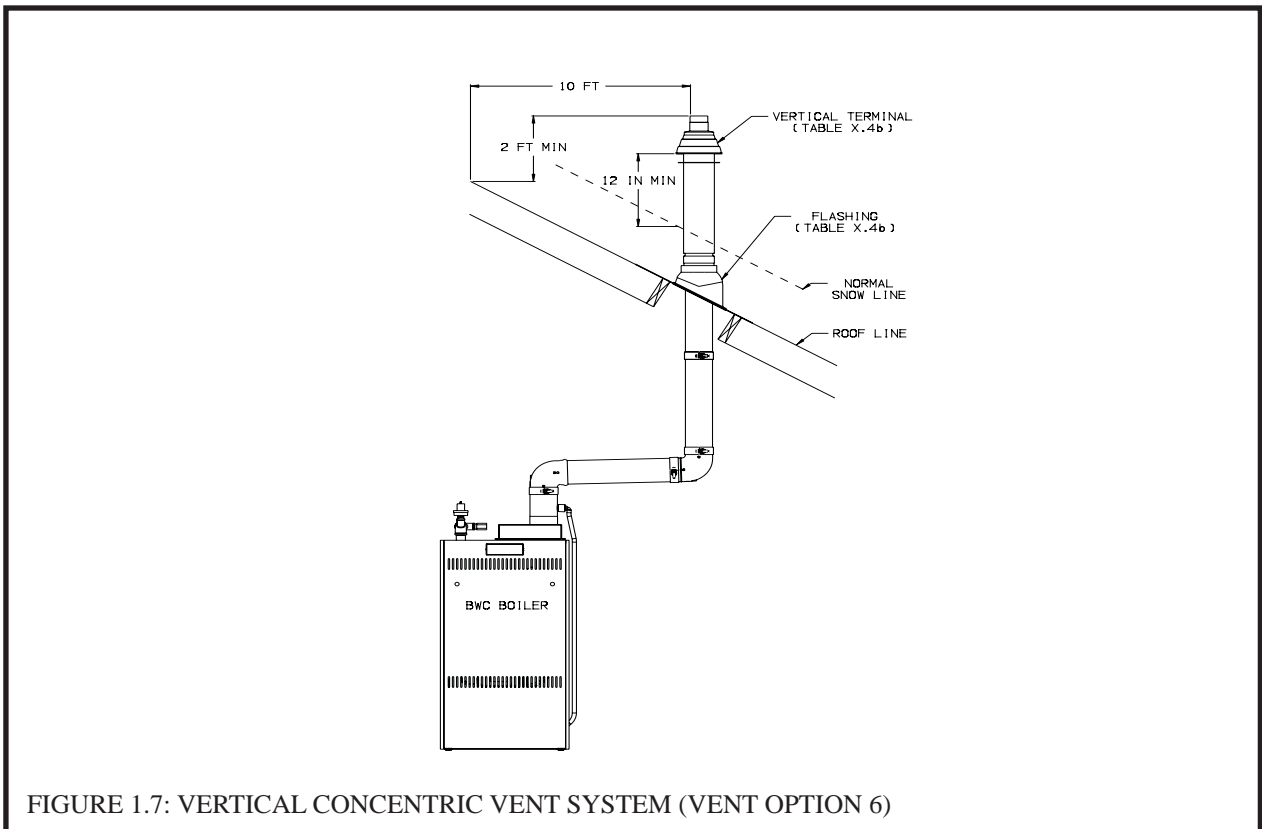

FIGURE 1.7: VERTICAL CONCENTRIC VENT SYSTEM (VENT OPTION 6)

B. Concentric Vent Adapter Kit Installation

1) The Concentric Vent Adapter Kits include:

P/N 230550 (BWC150)	P/N 230555 (BWC225)	Description
240470	240480	Rubber Gasket
240471	240481	Air Intake Box
90-054	90-054	#10 x 3/4" Sheet Metal Screws
240472	240482	Stainless Vent Adapter
230539	230575	Concentric Condensate Collector
240552	240552	Condensate Collector Adapter
240550	240550	Tapped Condensate Trap Plug
240560	240560	66'of 1/2" Clear PVC Tubing
240555	240555	90° Hose Barb (2)
240557	240557	1/2" Hose Clamps (2)

Where the use of "silicone" is called for in the following instructions, use GE RTV106 for the vent adapters and any general-purpose silicone sealant such as GE RTV102 for the air inlet piping connection.

- a) Start assembly of the air intake box by first removing the hose clamp shipped on the BWC vent collar. Bend the three hose clamp tabs on this collar inward slightly.
- b) Place the gasket over the vent collar and air intake collar as shown in Figure 1.8. The gasket should fit snugly against the vent collar and air intake collar with no gaps.
- c) Bend the three hose clamp tabs on the vent collar outward slightly.
- d) Clean the exterior of the male end and interior of the female end of the stainless vent adapter and the inside of the vent collar on the boiler. Remove dirt, grease, and moisture from the surfaces to be sealed. Dry surfaces or allow to dry thoroughly.

- e) On the male end of the stainless vent adapter, apply a 1/4" wide bead of silicone approximately 1/2" from the end of the pipe.
- f) Insert the male end of the stainless vent adapter into the boiler vent collar until it bottoms out.
- g) Apply an additional bead of silicone over the outside of the joint and smooth out.
- h) Replace and tighten the clamp on the vent collar.
- i) Remove one (BWC150) or two (BWC225) of the #10 sheet metal screws on the top of the rear jacket panel and place the air intake box over the vent and onto the boiler.
- j) Use the exposed holes to line up the air intake box and gasket.
- k) Insert the concentric condensate collector into the stainless vent adapter and the air intake box until the bead on the collector bottoms out on the air intake box collar. Turn the fitting so that the threaded stub faces to the right.
- l) Square up the air intake box and the foam rubber gasket to the boiler jacket and loosely attach the box to the rear jacket panel with one of the previously removed #10 sheet metal screws.
- m) Drill a single 1/8" hole through one of the mounting holes on the opposite side of the air intake box and attach the box to the jacket with one of the #10 sheet metal screws. This will insure the rest of the mounting holes line up.
- n) Drill 1/8" holes in through the remaining mounting holes and attach the air intake box and gasket to the boiler jacket with the remaining #10 sheet metal screws.
- o) Apply pipe thread sealant tape (not supplied) to the 90° barbed hose fittings. Attach one to the condensate collector adapter and the other to the bottom of the tapped condensate trap plug. (Figures 1.8, 1.15)
- p) Attach the condensate collector adapter to the threaded portion of pipe sticking out the side of the concentric condensate collector so that the hose barb is facing down. Slide one end of the 1/2" clear plastic tubing over the hose barb and attach the hose clamp.
- q) Run the tubing down the right side panel and into the 1-3/8" knockout located on the lower right of the right side panel. Be sure to remove all burrs from the knockout to prevent the hose from being punctured.
- r) Remove the plug and black gasket ring from the bottom of the condensate trap located under the boiler.
- s) Reinstall the gasket ring onto the tapped condensate trap plug. Insert the tapped plug (which has the barbed hose fitting attached to it) in the base of the trap in place of the original plug. Slide the other end of the clear plastic tubing over the hose barb and attach the hose clamp. (Figure 1.15)
- t) Allow the silicone to cure per the silicone manufacturer's instructions before operating the boiler.

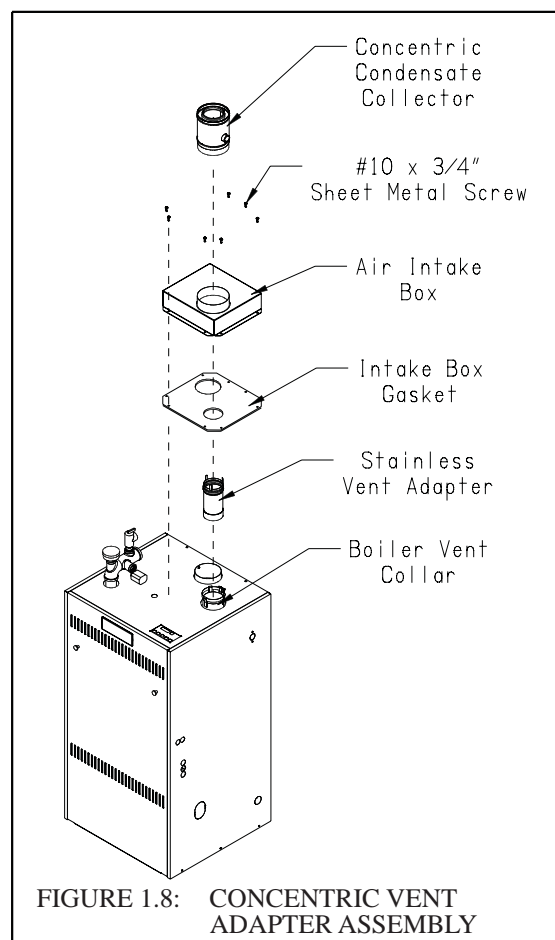

C. Assembly of Crown Concentric Venting

WARNING

Failure to follow the instructions could result in flue gas leakage into the combustion air or indoor air, resulting in unsafe or unreliable operation.

- Do not lubricate concentric gaskets with anything other than water.
- Do not attempt to cut any piping except as permitted in this section. When cutting these sections, make sure all cuts are square and allow for proper insertion.
- Do not attempt to try to mix this concentric pipe with other venting systems.

1) The components listed in Table 1.6 are required for 80/125mm and 100/150mm installations and are not supplied with the BWC150/225 boilers. Before starting assembly of the vent system, make sure that the planned installation is in accordance with the “Vent System Design” section of this manual and that all required vent components are on hand. These components are available through Crown distributors.

2) Cutting Straight Pipe - The following straight pipe sections may be cut:

80/125 Part #	100/150 Part #	Description
230517	230560	19 1/2” Straight
230515	230562	39” Straight

These sections have a plain male end (without beads - see Figure 1.9a). They are always cut from the male end. Sections not shown on the above list may not be cut. These sections have beads on the male end (Figure 1.9b). To cut the straight sections listed above refer to Figure 1.10 and the following instructions:

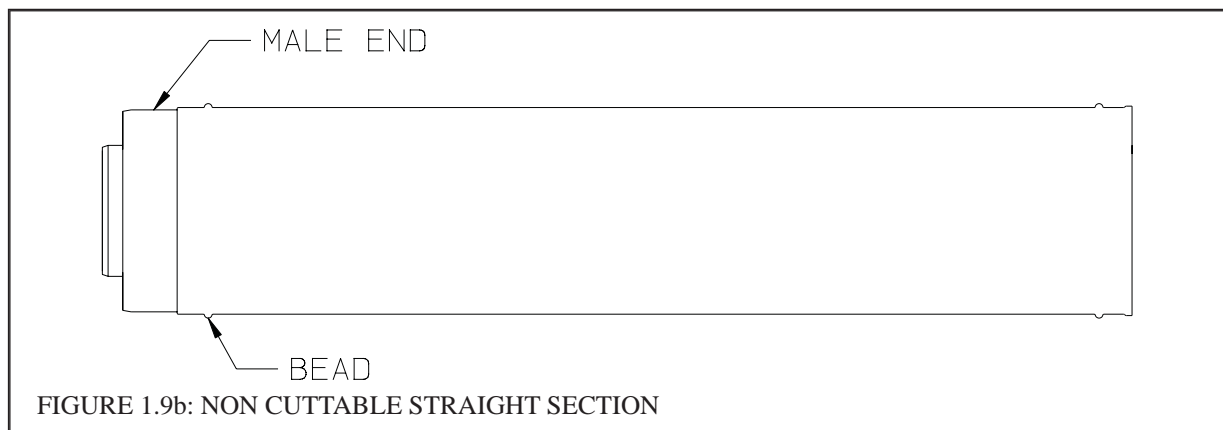
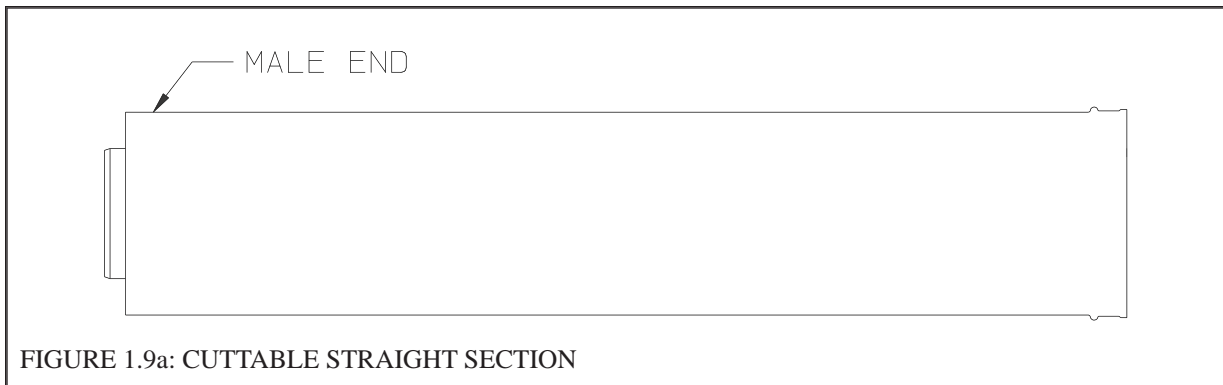

- a) Determine the required length of the outer pipe. When doing this allow an additional 1" of length for insertion into the female end of the adjoining pipe. Mark the cut line on the outer pipe.
- b) Remove the plastic inner pipe by pulling it out from the female end.
- c) Cut the **OUTER PIPE ONLY** at the point marked in Step (a) using aviation shears, a hacksaw, or an abrasive wheel cutter. Be careful to cut the pipe square. De burr the cut end with a file or emery cloth.
- d) Make an insertion mark 1" from the male end of the outer pipe.
- e) Cut the plastic inner pipe so that it will protrude 3/8" beyond the male end of the outer pipe when reinstalled in the outer pipe. Use a fine tooth hacksaw or a PVC saw to cut the plastic pipe and be careful to cut the pipe square. De burr the cut edge of the plastic pipe with a file, razor blade, or fine sandpaper.
- f) Reinstall the inner pipe.

3) Joining Pipe -

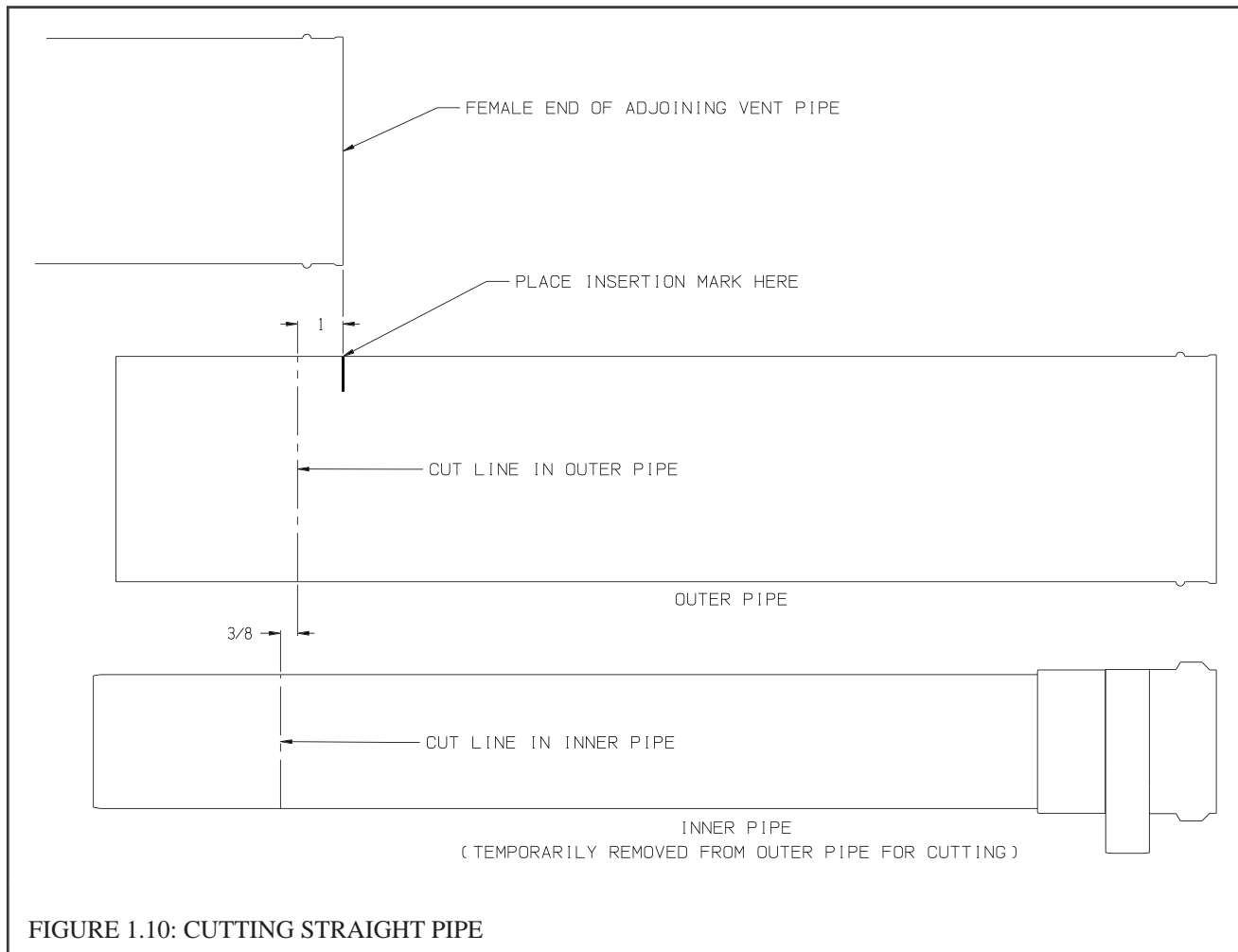
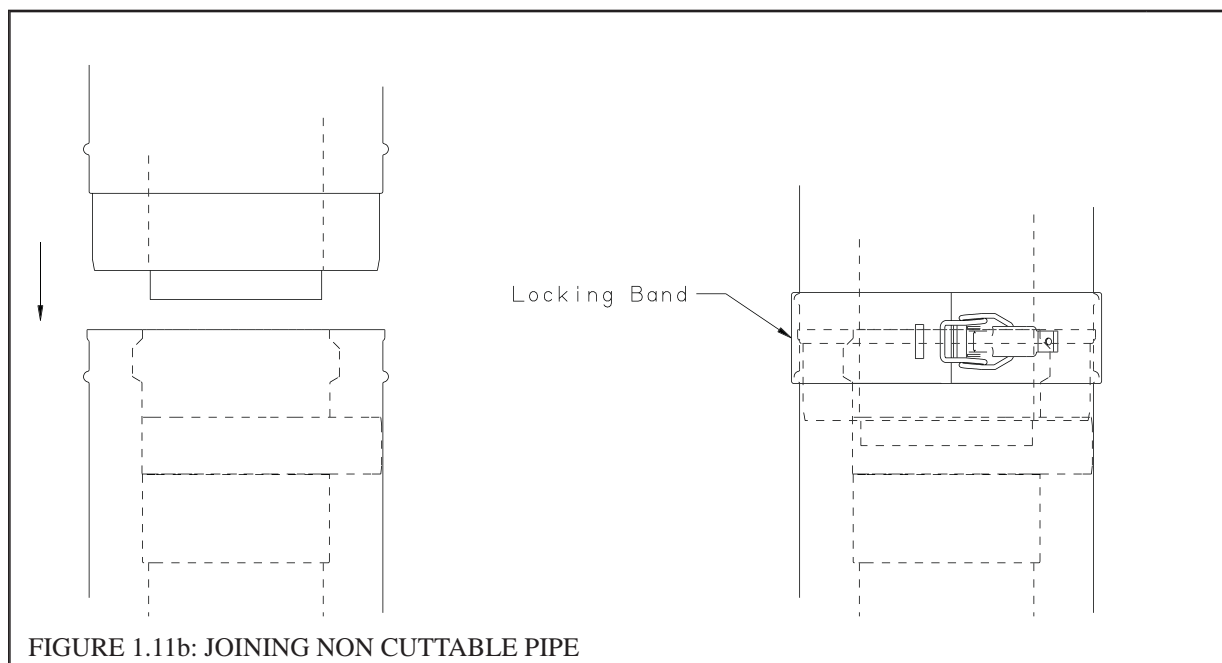
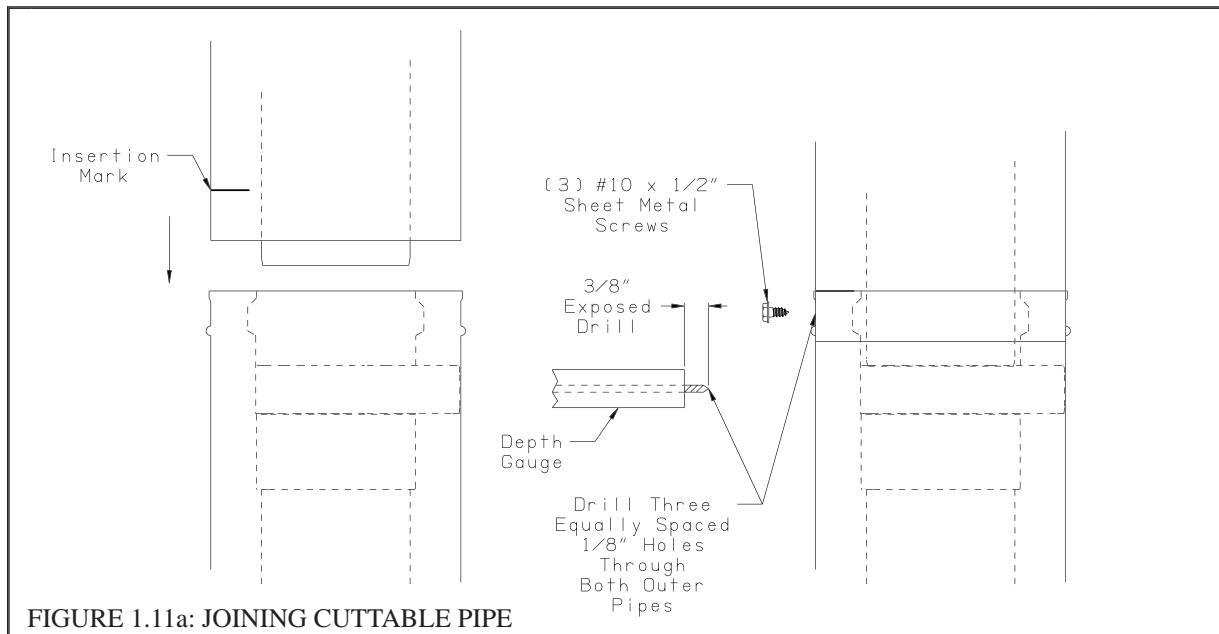

FIGURE 1.10: CUTTING STRAIGHT PIPE

- a) Start assembly of the vent system at the boiler. Lubricate the brown gasket in the boiler vent collar with a few drops of water.
- b) Push the male end of the first fitting into the boiler collar until it bottoms out. The male end of cuttable sections should go 1" into the collar until the insertion mark (made in Step 2d above) is covered. On other fittings, the bead on the male pipe will bottom out on the collar (Figure 1.11b).
- c) The male end of cuttable fittings must be held to the collar with three #10 x 1/2" sheet metal screws. Drill a 1/8 hole through both outer pipes to start this screw. **Use a drill stop or other means to ensure that the drill bit does not penetrate more than 3/8" into the outer pipe. Do not use a sheet metal screw longer than 1/2"** (Figure 1.11a).
- d) Use locking bands (provided with all fittings) to secure non-cuttable pipe, as well as fittings, to the boiler collar (Figure 1.11b).
- e) Use the same method to join all remaining vent components except for the terminal.

4) Horizontal Terminal Installation



- a) Cut a 5-1/2" diameter hole through the exterior wall at the planned location of the horizontal terminal.
- b) Measure distance "L" from the outside surface of the exterior wall to the end of the last fitting as shown in Figure 1.12a.
- c) Add 1-1/4" to distance "L". Carefully mark this length on the pipe as shown in Figure 1.12b.
- d) Remove the aluminum inner pipe from the terminal, by gently pulling on it from the male end. Set aside.
- e) Cut the **outer pipe only** at the point marked in Step (c) using aviation shears, a hacksaw, or an abrasive wheel cutter. Be careful to cut the pipe square. De-burr the cut end with a file or emory cloth.
- f) Reinstall the aluminum inner pipe in the terminal, making sure that the female end of this pipe is completely bottomed out over the aluminum male connection visible behind the air intake grill. Place a mark on the aluminum inner pipe 3/8" beyond the end of the outer pipe (Figure 1.12c). Use a fine tooth hacksaw or hand shears to cut the aluminum pipe and be careful to cut the pipe square (if necessary, the aluminum pipe can be removed from the terminal again for cutting). De-burr the cut edge of the aluminum pipe with a file or fine sandpaper.
- g) Make a mark on the terminal section 1" from the cut end of the outer pipe as shown in Figure 1.12c.
- h) Slip the terminal section through the wall from the outside. Pass the terminal through the inner wall plate and push into the last section of vent pipe until the mark made in Step (h) is not longer visible (Figure 1.12d). Secure the terminal to the last piece of pipe with three #10 x 1/2" sheet metal screws. Drill a 1/8" hole through both outer pipes to start these screws. **Use a drill stop or other means to ensure that the drill bit does not penetrate more than 3/8" into the outer pipe. Do not use a sheet metal screw longer than 1/2".**
- i) Slip the outer wall plate over the terminal and secure to the wall (Figure 1.12d). Apply a 1/8" bead of weather resistant RTV over the joint between the outside wall plate and the terminal. Secure the other wall plate to the inside wall.

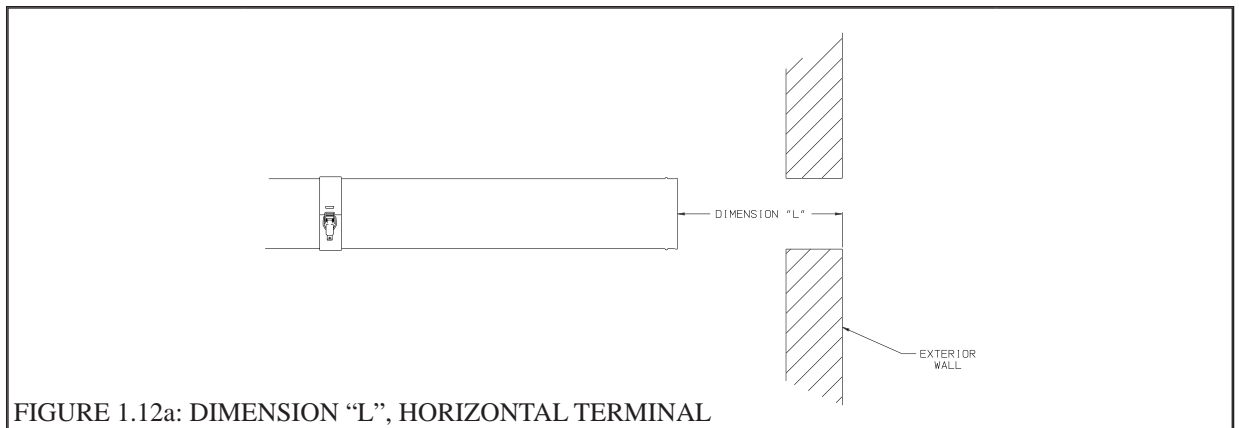

FIGURE 1.12a: DIMENSION "L", HORIZONTAL TERMINAL

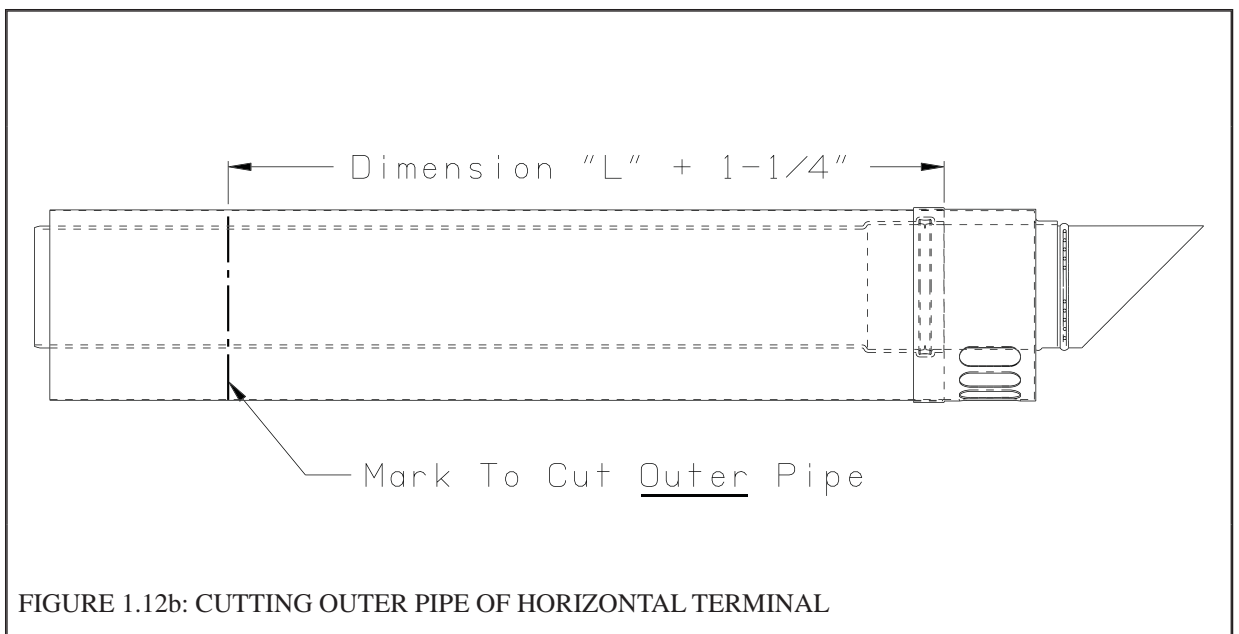
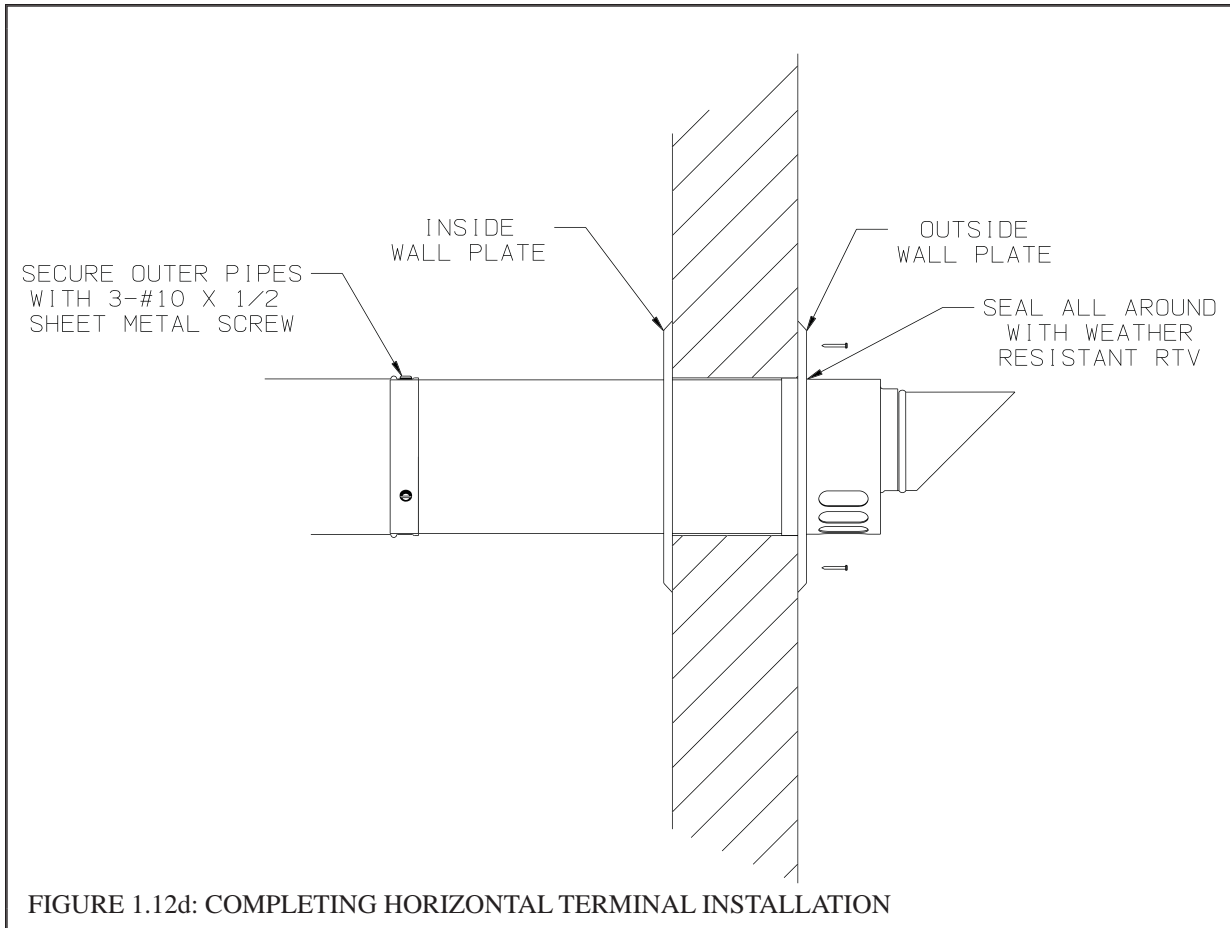
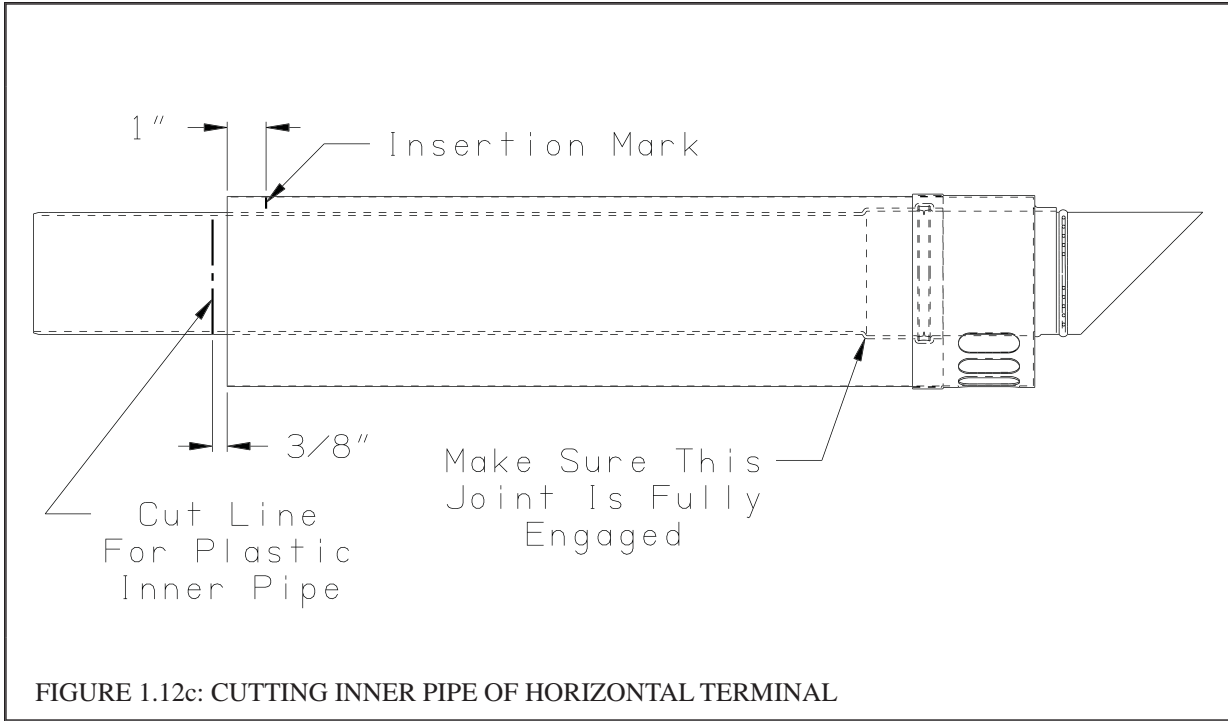
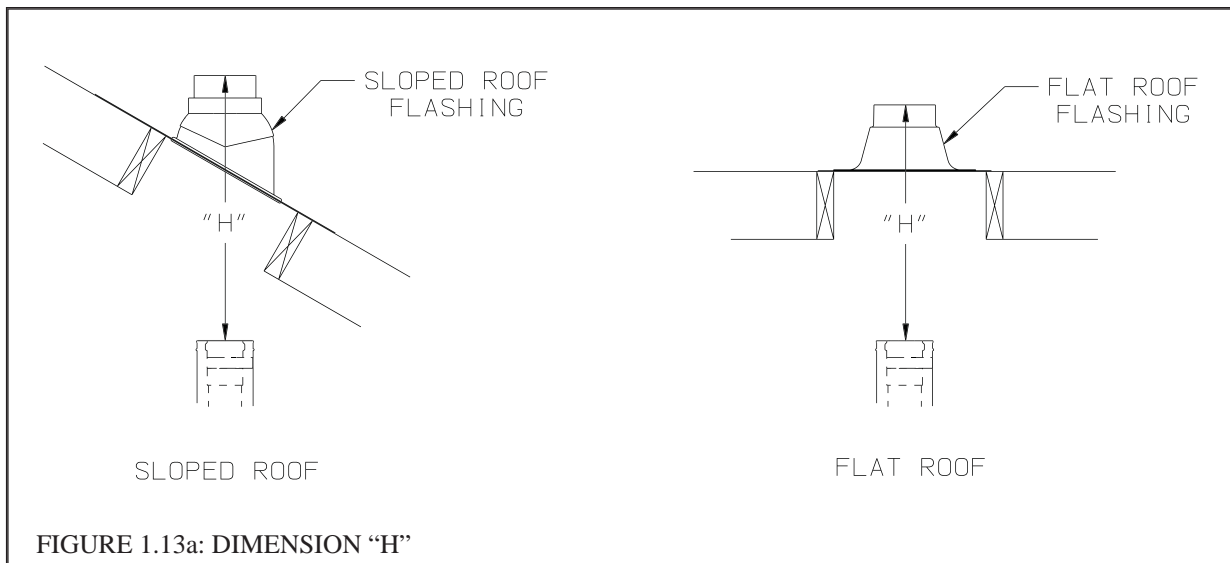

FIGURE 1.12b: CUTTING OUTER PIPE OF HORIZONTAL TERMINAL



- 6) **Vertical Terminal Installation** - In addition to the vertical terminal, either a Flat Roof Flashing (80/125 PN 230533, 100/150 PN 230571) or Sloped Roof Flashing (80/125 PN 230535, 100/150 PN 230572) is required for this installation.
- Determine the center line of the terminal location on the roof. If the roof is flat, cut a 5-1/2" diameter hole for the 80/125 terminal and a 6-1/2" diameter hole for the 100/150 terminal. If the roof is sloped, cut a hole large enough for the terminal to pass through the roof while remaining plumb. **Caution: If the boiler is installed directly under the hole, cover it while cutting the hole to prevent saw dust and other debris from falling into the boiler.**
 - Install the roof flashing using standard practice for the roofing system on the structure.
 - If not already done, assemble the venting system inside the building. The last section of pipe needs to be on the same center line as the terminal and within 19-1/4" (80/125) or 28" (100/150) of the top edge of the roof flashing (Figure 1.13a).
 - Measure distance "H" from the top edge of the storm collar to the end of the last fitting as shown in Figure 1.13a.
 - Add 1" to distance "H". Carefully mark this length on the pipe as shown in Figure 1.13b.
 - Cut the **outer pipe only** at the point marked in Step (e) using aviation shears, a hacksaw, or an abrasive wheel cutter. Be careful to cut the pipe square. De-burr the cut end with a file or emery cloth.
 - Place a mark on the aluminum inner pipe 3/8" beyond the end of the outer pipe (Figure 1.13b). Use a fine tooth hacksaw to cut the aluminum pipe and be careful to cut the pipe square. De-burr the cut edge of the aluminum pipe with a file or emery cloth.
 - Make a mark on the terminal section 1" from the cut end of the outer pipe as shown in Figure 1.13b.
 - Slip the terminal section through the roof from the outside. Push into the last section of vent pipe until the mark made in Step (h) is no longer visible. Secure the terminal to the last piece of pipe with three #10 x 1/2" sheet metal screws. Drill a 1/8" hole through both outer pipes to start these screws. **Use a drill stop or other means to ensure that the drill bit does not penetrate more than 3/8" into the outer pipe. Do not use a sheet metal screw longer than 1/2".**
 - Secure the terminal section to the inside of the roof structure using the mounting bracket provided with the terminal (Figure 1.13c).
- 7) **Chimney Chase Installation** - A vertical vent system can be installed in an unused masonry chimney. This installation is similar to other vertical installations with the following exceptions (Also see Figure 1.14):
- The chimney chase elbow kit (80/125 PN230530, 100/150 PN 230568) is used at the base of the chimney. This kit consists of a support elbow and a mounting bracket. Slip the elbow over the M10 x 35 screw in the support bracket. Determine the desired vertical location of the support elbow in the chimney and mark the location of the pin on the back of the support bracket on the back wall of the chimney. Drill a 7/16" dia x 2-1/2" deep hole at this location to support the back of the bracket. The front of the elbow mounting bracket is supported by the bottom of the opening into the chimney or by an installer supplied bracket.
 - Construct a weather-tight flat roof to cover the top of the old chimney. Install the vertical terminal through this roof using the flat roof flashing.



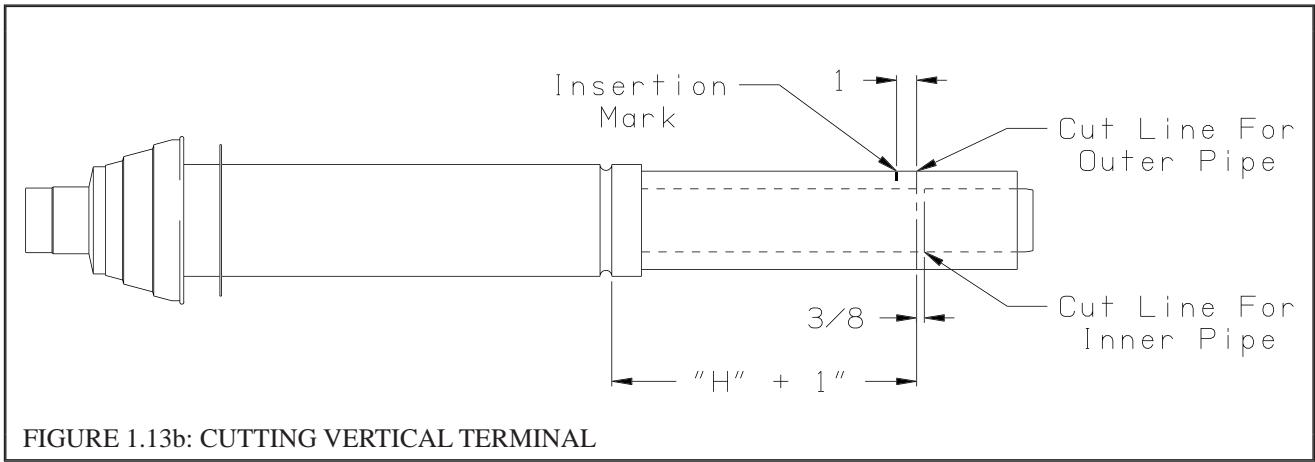

FIGURE 1.13b: CUTTING VERTICAL TERMINAL

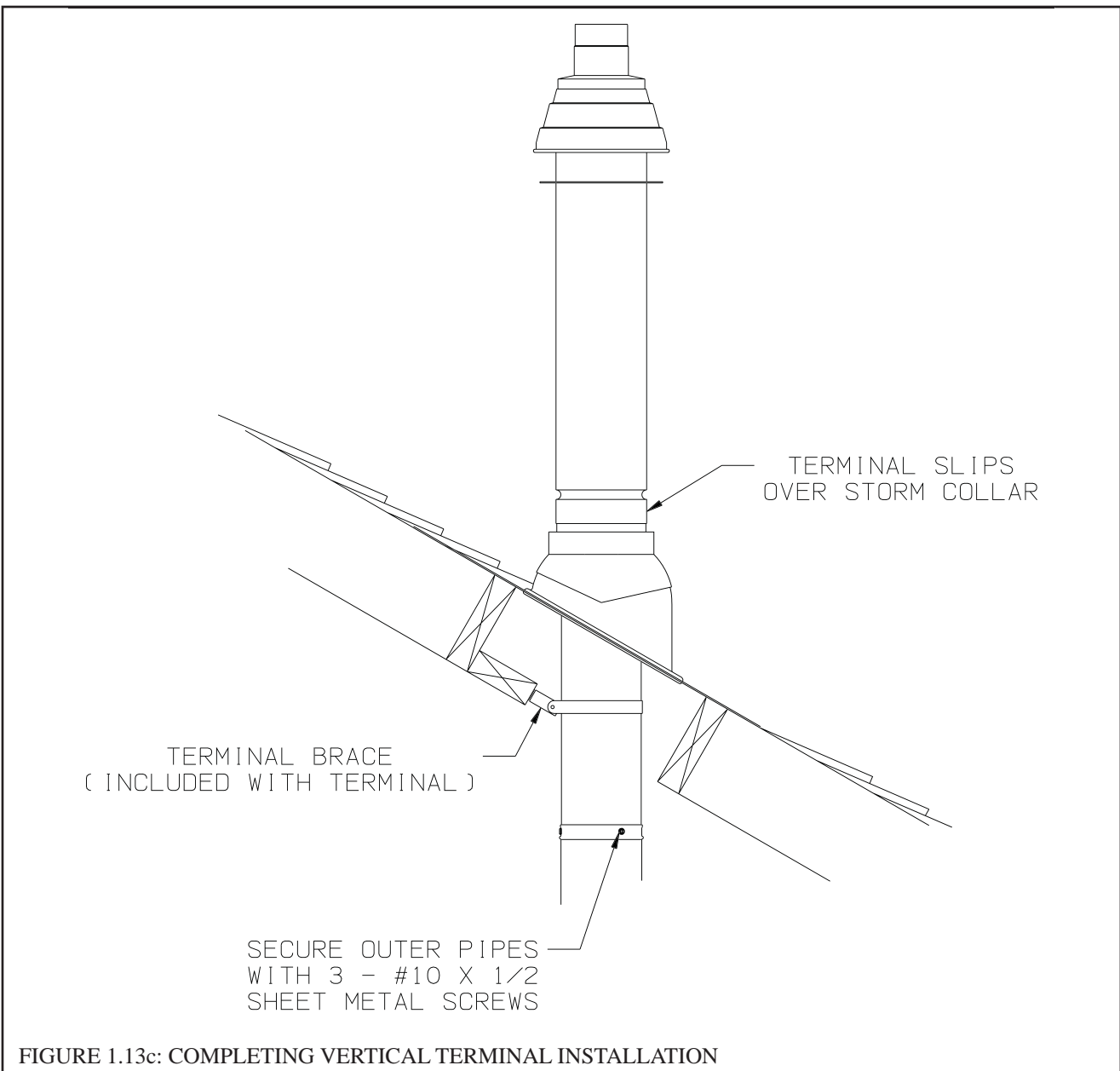

FIGURE 1.13c: COMPLETING VERTICAL TERMINAL INSTALLATION

WARNING

- Do not attempt to construct a vertical vent system inside a chimney that is used to vent a fireplace or other appliances.
- Do not attempt to construct a vertical vent system inside a chimney flue adjacent to another flue used by a fireplace or other appliances.

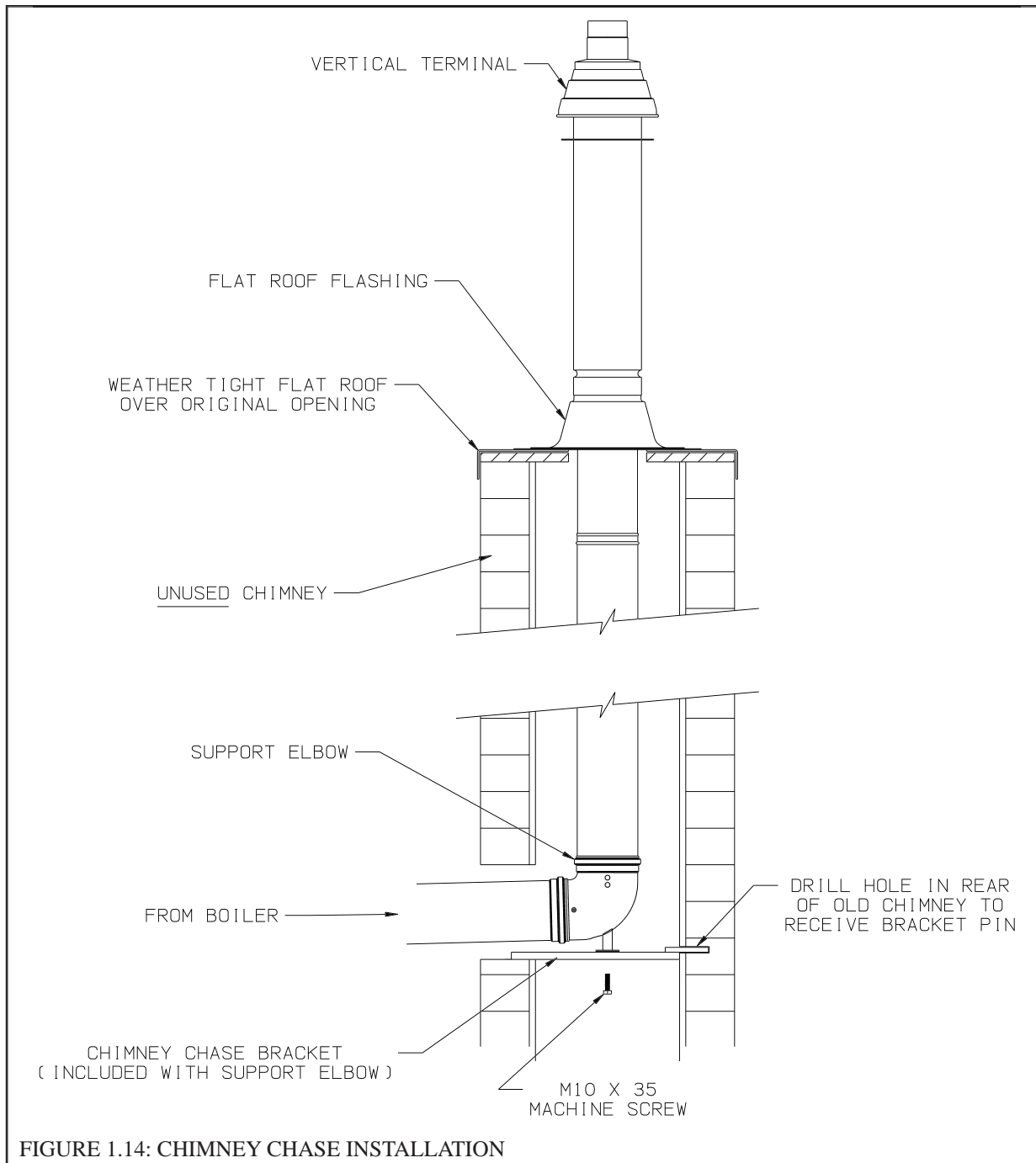

FIGURE 1.14: CHIMNEY CHASE INSTALLATION

8) Condensate Drain Line - In systems where a concentric vent is used, all condensate which forms in the boiler or vent system collects in both the condensate vent adapter and the sump under the heat exchanger and leaves the boiler through the condensate trap. This trap allows condensate to drain from the boiler and vent while retaining flue gases. A length of corrugated drain hose is supplied with the boiler and is connected to the trap as shown in Figure 1.15. This hose may be routed through the back of the boiler or to the left side through the knockout provided. Route this hose to a drain or other suitable point for disposal. Note the following when disposing of the condensate:

- a) If the condensate drain line must be extended, construct the extension from PVC or CPVC pipe. Insert the hose provided with the boiler into the end of the extension as shown in Figure 1.15.
- b) Condensate is slightly acidic. Do not use metallic pipe or fittings in the condensate drain line. Do not route the drain line through areas that could be damaged by leaking condensate.
- c) Some jurisdictions may require that the condensate be neutralized before being disposed of. Dispose of condensate in accordance with local codes.
- d) Do not route, or terminate, the condensate drain line in areas subjected to freezing temperatures.
- e) If the point of condensate disposal is above the trap, it will be necessary to use a condensate pump to move the condensate to the drain. In such cases, select a condensate pump that is approved for use with condensing furnaces. If overflow from this pump would result in property damage, select a pump with an overflow switch and use this switch to shut down the boiler. Alternatively, if heat is a necessity, use the overflow switch to trigger an alarm.
- f) Do not attempt to move the trap from the location shown in Figure 1.15. Do not attempt to substitute another trap for the one provided with the boiler.
- g) The vent shown in Figure 1.15 must be left open for the trap to work properly.

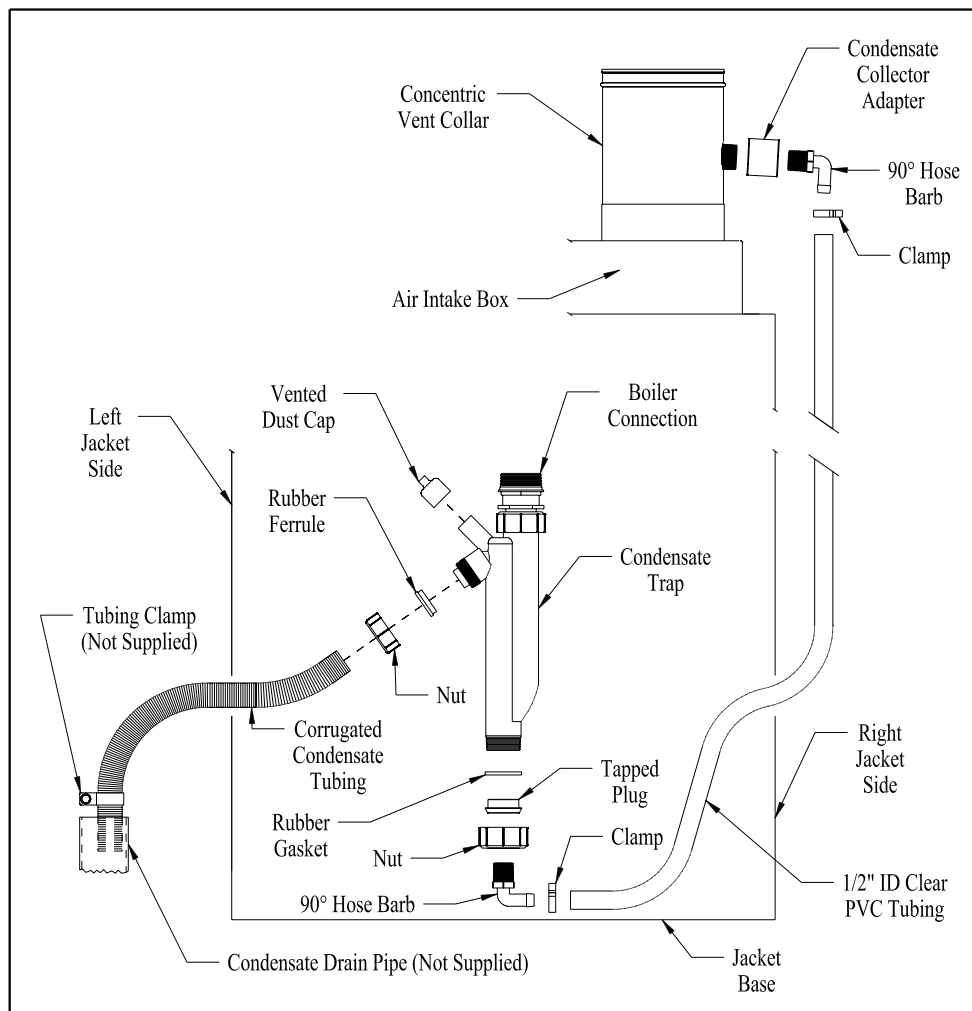

FIGURE 1.15: CONDENSATE DRAIN LINE ASSEMBLY

CROWN Boiler Co.

Manufacturer of Hydronic Heating Products

P.O. Box 14818 3633 I. Street

Philadelphia, PA 19134

Tel: (215) 535-8900 • Fax: (215) 535-9736 • www.crownboiler.com

PN: 980241 Rev. 0
BWC - 12/07

Free Manuals Download Website

<http://myh66.com>

<http://usermanuals.us>

<http://www.somanuals.com>

<http://www.4manuals.cc>

<http://www.manual-lib.com>

<http://www.404manual.com>

<http://www.luxmanual.com>

<http://aubethermostatmanual.com>

Golf course search by state

<http://golfingnear.com>

Email search by domain

<http://emailbydomain.com>

Auto manuals search

<http://auto.somanuals.com>

TV manuals search

<http://tv.somanuals.com>