



D E S I G N E D T O L E A D

BWC Series

High Efficiency Gas-Fired Hot Water
Direct Vent Condensing Boilers

INSTALLATION INSTRUCTIONS

These instructions must be affixed on or adjacent to the boiler.

Models:

- BWC070
- BWC090
- BWC120
- BWC151



WARNING: Improper installation, adjustment, alteration, service or maintenance can cause property damage, injury, or loss of life. For assistance or additional information, consult a qualified installer, service agency or the gas supplier. This boiler requires a special venting system. Read these instructions carefully before installing.



Manufacturer of Hydronic Heating Products
P.O. Box 14818 3633 I. Street
Philadelphia, PA 19134

Tel: (215) 535-8900 • Fax: (215) 535-9736 • www.crownboiler.com

Table of Contents

I.	Product Description	2
II.	Specifications	2
III.	Before Installing	3
IV.	Locating The Boiler	3
V.	Mounting The Boiler	6
VI.	Air For Ventilation	9
VII.	Venting	11
	A. Vent System Design	11
	B. Removing An Existing Boiler From Common Chimney	21
	C. Assembly of Crown 60/100mm Concentric Venting	22
	D. Assembly of Crown 80/125mm Concentric Venting	26
	E. Assembly of Stainless Steel Venting	35
	F. Condensate Trap and Drain	40
VIII.	Gas Piping	42
IX.	System Piping	43
	General System Piping Precaution	43
	System Design	43
	Standard Piping Installation Requirements	50
	Piping For Special Situations	51
X.	Wiring	53
XI.	Start-up and Checkout	57
XII.	Operation	63
XIII.	Service and Maintenance	68
XIV.	Troubleshooting	70
XV.	Parts	73
	Appendix A: Optional Method for Retrofitting BWC Boilers into Existing Circulator Zone Systems	85
	Appendix B: Special Requirements For Side-Wall Vented Appliances In The Commonwealth of Massachusetts	87

I Product Description

The BWC070, BWC090, BWC120 and BWC151 are aluminum gas fired condensing boilers designed for use in forced hot water heating systems requiring supply water temperatures of 180°F or less. These boilers are designed for installation on a wall, however they may be floor mounted using an optional pedestal kit available from Crown. This boiler may be vented vertically or horizontally with combustion air supplied from outdoors. This boiler is not designed for use in gravity hot water systems or systems containing significant amounts of dissolved oxygen.

II Specifications

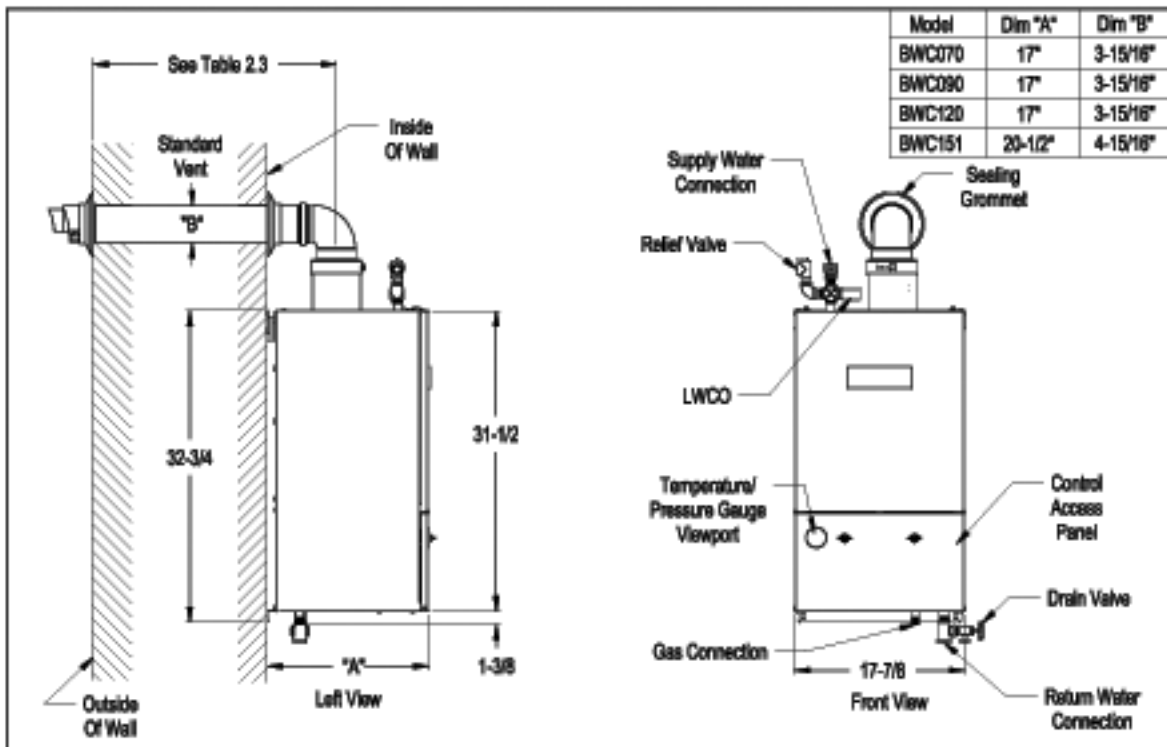

Figure 2.1: General Configuration

Table 2.2: Specifications

MODEL*	NO. OF SECTIONS	MAXIMUM INPUT (BTU/hr)	MINIMUM INPUT (BTU/hr)	D.O.E. HEATING CAPACITY (BTU/hr)	IBR NET RATING (BTU/hr)	AFUE (%)	WATER VOLUME (Gal.)	APPROX. NET WEIGHT (lb)
BWC070	mono block	70,000	30,000	63,000	55,000	95.4	0.41	102
BWC090	mono block	90,000	30,000	80,000	70,000	94.5	0.41	102
BWC120	mono block	120,000	40,000	107,000	93,000	95.2	0.62	110
BWC151	mono block	150,000	50,000	135,000	117,000	95.2	1.13	133

* Add suffix "EN" for natural gas and "EL" for propane. Ratings are the same for both fuels.

Table 2.3: Maximum Vent Lengths

Using Concentric Vent System Supplied with the Boiler.....	25 in.
Using Optional 60/100mm Concentric Vent Components:	
BWC070.....	32 ft
BWC090.....	32 ft
BWC120.....	18 ft
Using Optional 80/125 Vertical Concentric Vent System.....	95ft
Using Optional 80/125 Horizontal Concentric Vent System.....	100ft
Using Approved 3" AL29-4C Horizontal Stainless Vent System and Optional Stainless Steel Vent Kit.....	100 ft

See Vent Section for additional venting options and requirements.

III Before Installing

- 1) Safe, reliable operation of this boiler depends upon installation by a professional heating contractor in strict accordance with this manual and the authority having jurisdiction.
 - In the absence of an authority having jurisdiction, installation must be in accordance with this manual and the National Fuel Gas Code, ANSI Z223.1. In Canada, installation must be in accordance with the B149.1 Installation Code
 - Where required by the authority having jurisdiction, this installation must conform to the Standard for Controls and Safety Devices for Automatically Fired Boilers (ANSI/ASME CSD-1).
- 2) BWC boilers utilize aluminum heat exchangers constructed, tested, and stamped in accordance with ASME Boiler and Pressure Vessel Code Case 2382. Some jurisdictions which require ASME boiler construction do not recognize this Code Case and may not approve the installation of an aluminum boiler. Consult the authority having jurisdiction before installing this boiler.
- 3) Read Section VII to verify that the maximum combustion air and exhaust pipe lengths will not be exceeded in the planned installation. Also verify that the vent terminal can be located in accordance with Section VII.
- 4) Make sure that the boiler is correctly sized:
 - For heating systems employing convection radiation (baseboard or radiators), use an industry accepted sizing method such as the I=B=R Heat Loss Calculation Guide (Pub. #H21 or #H22) published by the Hydronics Institute in Berkely Heights, NJ.
 - For new radiant heating systems, refer to the radiant tubing manufacturer's boiler sizing guidelines.
 - For systems including a Crown Mega-Stor indirect water heater, size the boiler to have either the DOE Heating Capacity required for the Mega-Stor or the net rating required for the heating system, whichever results in the larger boiler.
 - For systems that incorporate other indirect water heaters, refer to the indirect water heater manufacturer's instructions for boiler output requirements.
- 5) Make sure that the boiler received is configured for the correct gas (natural or LP).
- 6) Make sure that the boiler is configured for use at the altitude at which it is to be installed.

NOTICE

This product must be installed by a licensed plumber or gas fitter when installed within the Commonwealth of Massachusetts. See Appendix A for additional important information about installing this product within the Commonwealth of Massachusetts.

IV Locating the Boiler

- 1) Observe the minimum clearances shown in Figure 4.1. These clearances apply to both combustible and non-combustible materials. Observe the minimum clearances to combustibles for vent pipe shown in Table 4.2.
- 2) Note the recommended service clearances in Figure 4.1. These service clearances are recommended, but may be reduced to the combustible clearances provided:
 - a. Access to the front of the boiler is provided through a door.
 - b. Access is provided to the condensate trap and transformer located underneath the boiler.
- 3) When the boiler is installed on the floor using the optional pedestal kit, the boiler may be installed on a non-carpeted combustible surface.
- 4) The relief valve must be installed in the factory specified location.

- 5) The boiler should be located so as to minimize the length of the vent system.
- 6) The combustion air piping must terminate where outdoor air is available for combustion and away from areas that will contaminate combustion air. Avoid areas near chemical products containing chlorine, chloride based salts, chloro/fluorocarbons, paint removers, cleaning solvents and detergents.

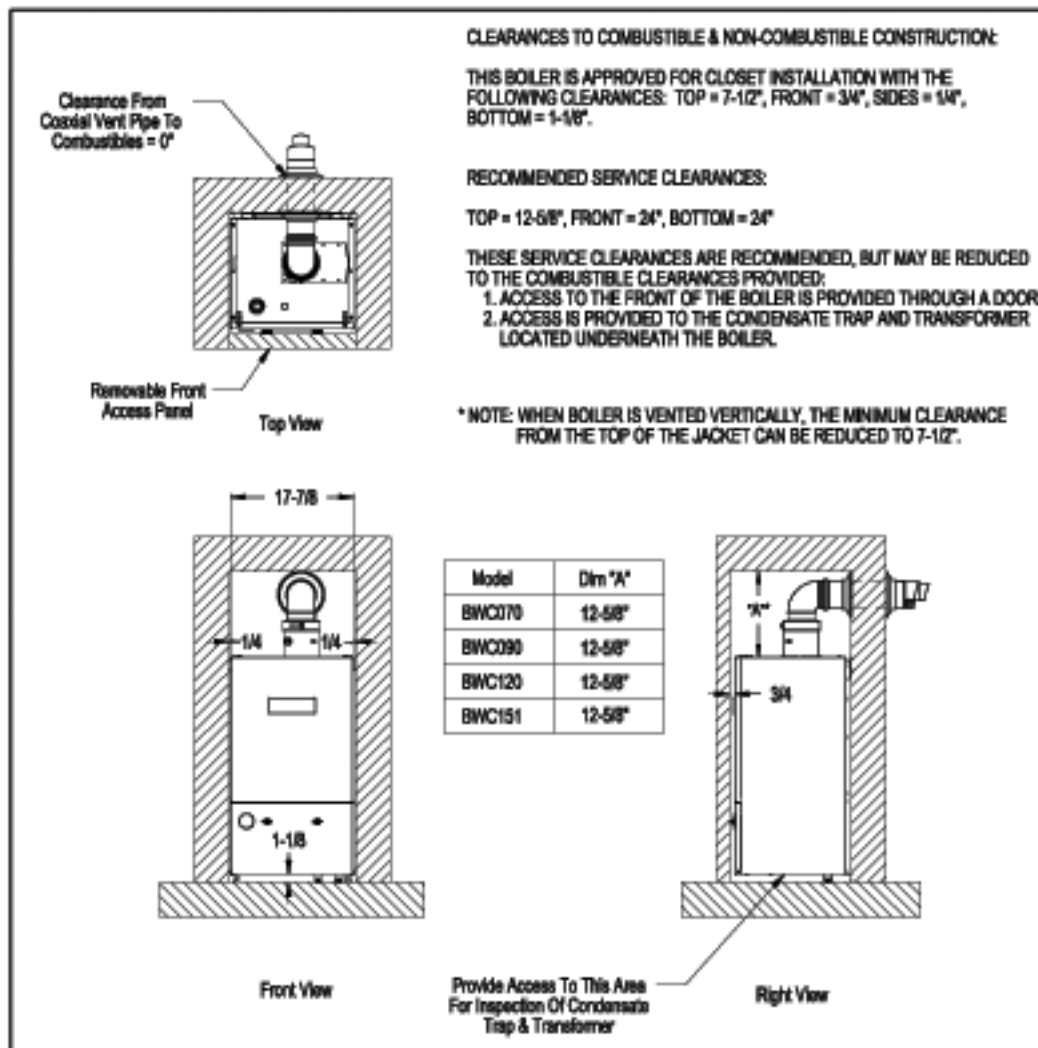

Figure 4.1: Clearances To Combustible Or Non-combustible Material

Table 4.2: Clearances From Vent Piping To Combustible Construction

TYPE OF VENT PIPE	PIPE DIRECTION	ENCLOSURE	MINIMUM CLEARANCE TO COMBUSTIBLE MATERIAL
80/125 and 60/100mm CONCENTRIC VENTING	VERTICAL OR HORIZONTAL	ENCLOSED ON ALL FOUR SIDES	0"
HEAT FAB SAF-T VENT PROTECH FASNSEAL Z-FLEX Z-VENT III METAL-FAB CORR/GUARD	VERTICAL OR HORIZONTAL	AT LEAST ONE SIDE OPEN, COMBUSTIBLE MATERIAL ON A MAXIMUM OF THREE SIDES	1"
HEAT FAB SAF-T VENT PROTECH FASNSEAL Z-FLEX Z-VENT III METAL-FAB CORR/GUARD	HORIZONTAL OR VERTICAL WITH OFFSETS	ENCLOSED ON ALL FOUR SIDES	2-1/2"
HEAT FAB SAF-T VENT PROTECH FASNSEAL Z-FLEX Z-VENT III METAL-FAB CORR/GUARD	VERTICAL WITH NO OFFSETS	ENCLOSED ON ALL FOUR SIDES	2-1/2"

V Mounting The Boiler

A. Wall Mounting

CAUTION

This boiler weighs approximately 133 pounds:

- Two people are required to safely lift this boiler onto the wall mounting hook.
- Make sure that wall mounting hook is anchored to a structure capable of supporting the weight of the boiler and attached piping when filled with water. Jurisdictions in areas subject to earthquakes may have special requirements for supporting this boiler. These local requirements take precedence over the requirements shown below.

- 1) If the boiler is installed on a framed wall, minimum acceptable framing is 2 x 4 studs on 16" centers. The boiler mounting holes are on 16" centers for installation between two studs at the standard spacing. In cases where the boiler cannot be centered between the studs, or where the studs are spaced closer than 16" apart, the boiler may be anchored to 3/4" plywood or horizontal 2 x 4s anchored to the studs.
- 2) 5/16" x 2" lag screws and washers are provided for mounting this boiler. These lag screws are intended for mounting the boiler directly onto studs covered with 1/2" sheet rock. When the boiler is attached to other types of construction, such as masonry, use fasteners capable of supporting the weight of the boiler and attached piping in accordance with good construction practice and applicable local codes.
- 3) Make sure that the surface to which the boiler is mounted is plumb.
- 4) Before mounting the boiler, make sure that wall selected does not have any framing or other construction that will interfere with the vent pipe penetration.
- 5) Once a suitable location has been selected for the boiler, and any needed modifications have been made to the wall, use Figure 5.1 to locate holes "A" and "B". Make sure that the horizontal centerline of these holes is level. Holes "C" and "D" may also be drilled at this time or after the boiler is hung on the wall. If the 5/16" x 2" lag screws are used, drill 3/16" pilot holes.
- 6) Cut the opening/s in the wall for the vent system. The recommended hole diameter is 4-3/8" for 60/100mm coaxial pipe and 5-3/8" for 80/125mm pipe.
- 7) Attach the wall hanging hook using the 5/16" x 2" lag screws and washers, or other suitable anchors as appropriate (Figure 5.2). Make sure the hook is level.
- 8) Hang the boiler on the wall hook as shown in figure 5.2.
- 9) If not already done in Step (4) locate and drill holes "C" and "D" using the ob-round slots in the bottom mounting flange. Secure the bottom flange to the wall using the 5/16" x 2" lag screws, or other fasteners as appropriate (figure 5.2).
- 10) Verify that the front of the boiler is plumb. If it is not, install washers at holes "C" and "D" between the bottom mounting flange and the wall to adjust.
- 10) See Section VII (Venting) for instructions on attaching the vent system to the boiler.

B. Floor Mounting

This boiler may be mounted on the floor using an optional pedestal kit available from Crown. Follow the instructions provided with this kit to assemble the pedestal, and attach it to the boiler. When this pedestal is used, the boiler may be installed directly on a non-carpeted combustible floor.

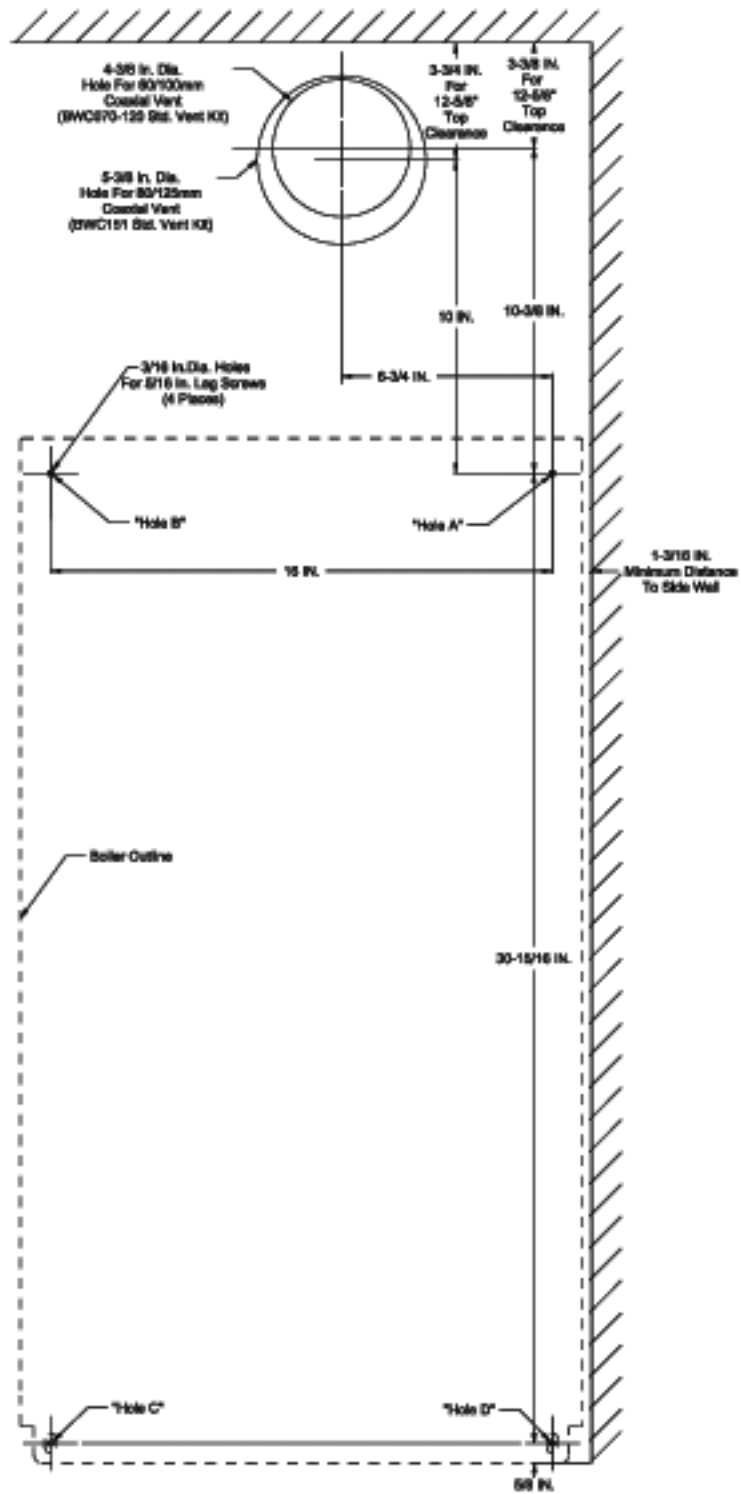

Figure 5.1 Wall Mounting Hole Locations

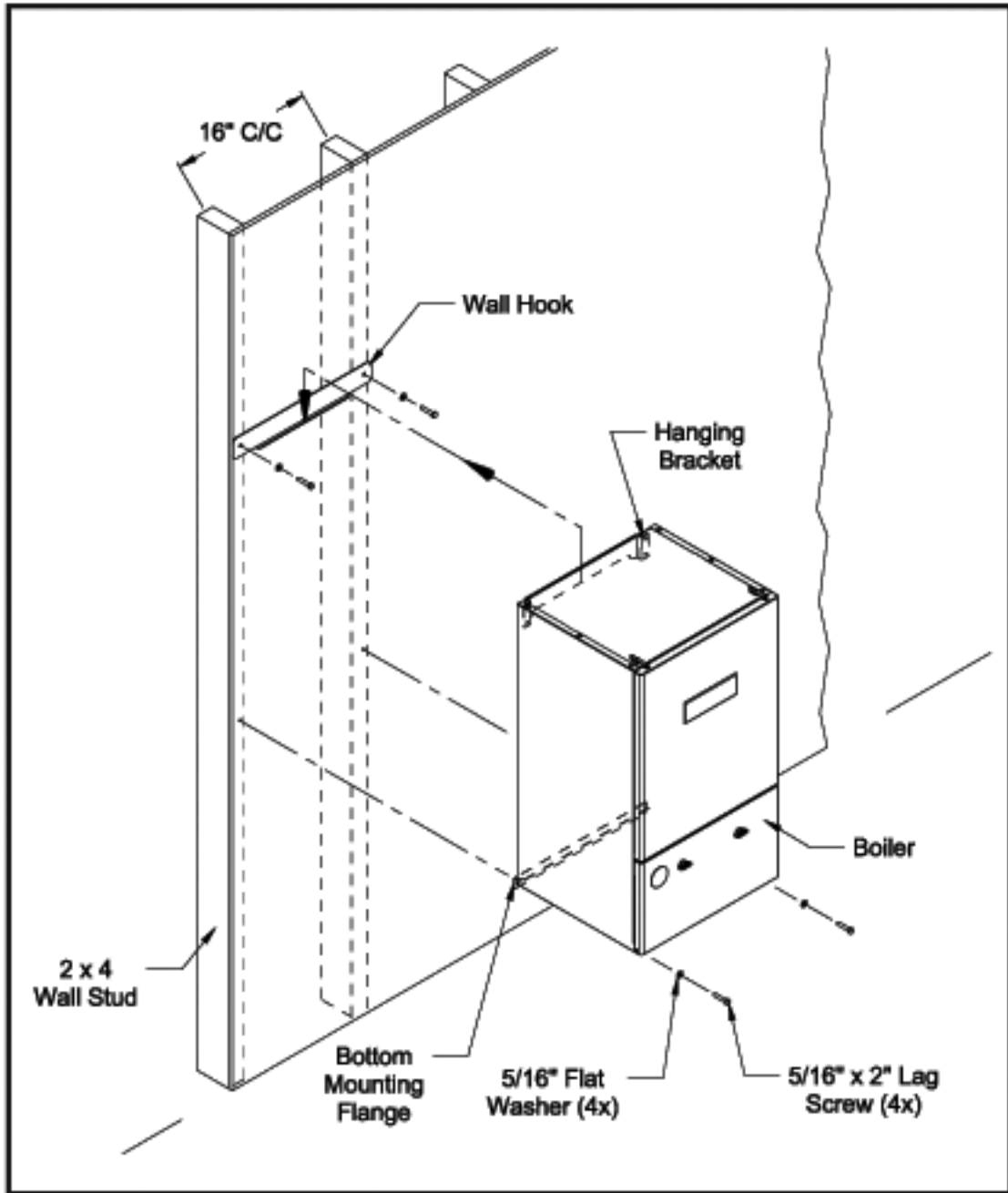

Figure 5.2 Boiler Mounting/Hardware

VI Air for Ventilation

WARNING

OUTDOOR COMBUSTION AIR MUST BE PIPED TO THE AIR INTAKE. NEVER PIPE COMBUSTION AIR FROM AREAS CONTAINING CONTAMINATES SUCH AS SWIMMING POOLS AND LAUNDRY ROOM EXHAUST VENTS. CONTAMINATED COMBUSTION AIR WILL DAMAGE THE BOILER AND MAY CAUSE PROPERTY DAMAGE, PERSONAL INJURY OR LOSS OF LIFE.

Air for combustion must always be obtained directly from outdoors, however sufficient air for ventilation must still be provided in the boiler room. Air for ventilation is required to keep various boiler components from overheating and is always obtained from indoors. To ensure an adequate ventilation air supply, perform the following steps:

Step 1: Determine whether the boiler is to be installed in a confined space - A confined space is defined by the National Fuel Gas Code as having a volume less than 50 cubic feet per 1000 BTU/hr input of all appliances installed in that space. To determine whether the boiler room is a confined space:

- 1) Total the input of all appliances in the boiler room in thousands of BTU/hr. Round the result to the next highest 1000 BTU/hr.
- 2) Find the volume of the room in cubic feet. The volume of the room in cubic feet is:

Length (ft) x width (ft) x ceiling height (ft)

In calculating the volume of the boiler room, consider the volume of adjoining spaces only if no doors are installed between them. If doors are installed between the boiler room and an adjoining space, do not consider the volume of the adjoining space, even if the door is normally left open.

- 3) Divide the volume of the boiler room by the input in thousands of BTU/hr. If the result is less than 50, the boiler room is a confined space.

Example:

A BWC120 and a water heater are to be installed in a room measuring 6ft – 3 in x 7ft with an 8 ft ceiling. The water heater has an input of 30000 BTU/hr:

Total input in thousands of BTU/hr = (120000 BTU/hr + 30000 BTU/hr) / 1000 = 150 MBTU/hr

Volume of room = 6.25 ft x 7 ft x 8 ft = 350 ft³

350/150 = 2.33. Since 2.33 is less than 50, the boiler room is a confined space.

Step 2a: If the boiler is to be placed in a confined space, provide two openings into the boiler room, one near the floor and one near the ceiling. The top edge of the upper opening must be within 12” of the ceiling and the bottom edge of the lower opening must be within 12” of the floor (Fig 6.1). The minimum opening dimension is 3 inches.

- If the BWC boiler is the only gas-burning appliance in the boiler room, these openings must each have a minimum free area of 100 square inches.
- If other gas-burning appliances are in the boiler room, size the openings in accordance with the appliance manufacturer’s instructions or the National Fuel Gas Code. Minimum opening free area is 100 square inches even if opening requirements for other appliances are less.

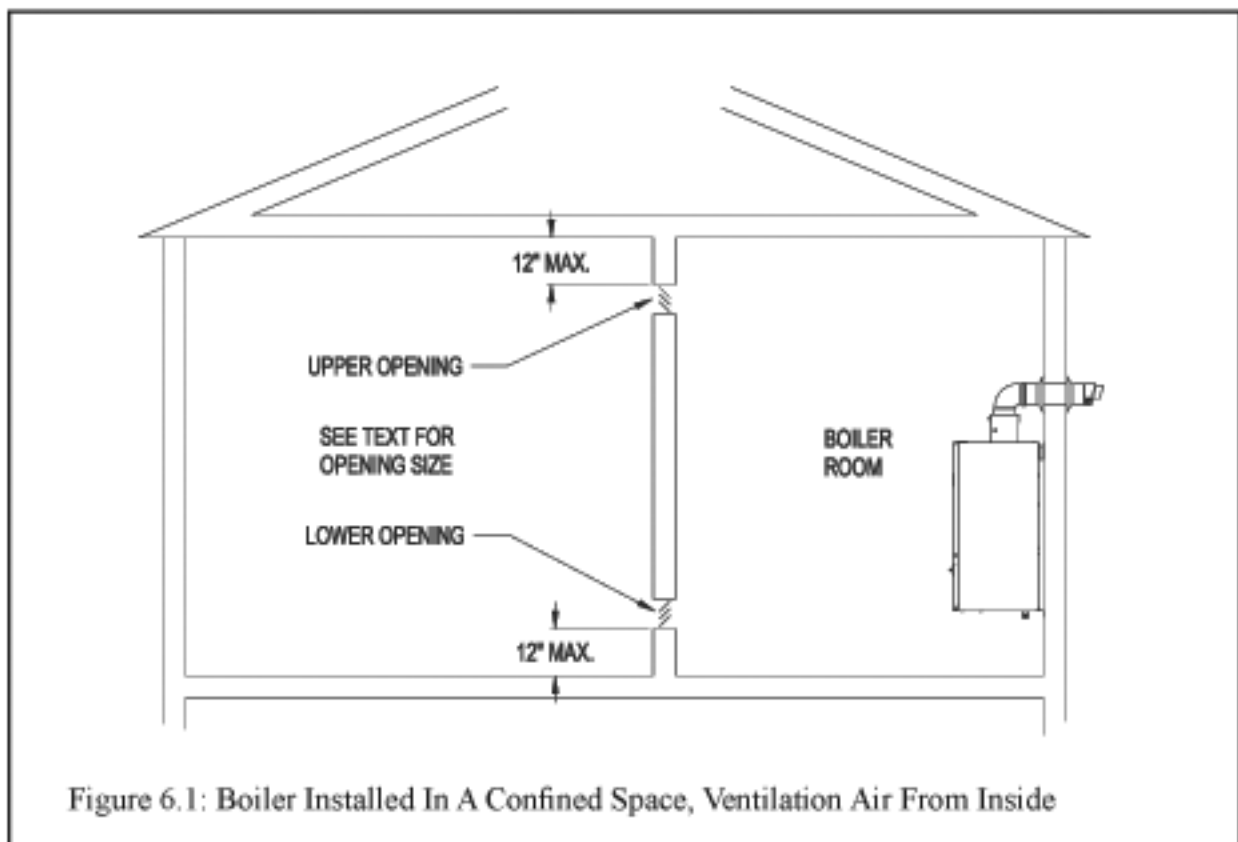

- If the total volume of both the boiler room and the room to which the openings connect is less than 50 cubic feet per 1000 BTU/hr of total appliance input, install a pair of identical openings into a third room. Connect additional rooms with openings until the total volume of all rooms is at least 50 cubic feet per 1000 BTU/hr of input.
- The "free area" of an opening takes into account the blocking effect of mesh, grills, and louvers. Where screens are used, they must be no finer than $\frac{1}{4}$ " (4 x 4) mesh.

Step 2b: If the boiler is to be placed in an unconfined space the natural infiltration into the boiler room will provide adequate air for ventilation without additional openings into boiler room.

VII Venting

WARNING

FAILURE TO VENT THIS BOILER IN ACCORDANCE WITH THESE INSTRUCTIONS COULD CAUSE FLUE GAS TO ENTER THE BUILDING RESULTING IN SEVERE PROPERTY DAMAGE, PERSONAL INJURY, OR DEATH:

- * Use only vent systems and materials explicitly permitted by Crown for use with this boiler.
- * Do not attempt to mix components from different approved vent systems.
- * Do not obtain combustion air from within the building.
- * Do not install a barometric damper or draught hood on this boiler.

CAUTION

Moisture and ice may form on the surfaces around the vent termination. To prevent deterioration, surfaces should be in good repair (sealed, painted, etc.).

A. Vent System Design

There are four basic ways to vent this boiler:

- **Horizontal (“Side Wall”) Concentric Venting** - Vent system exits the building through an outside wall. Concentric venting consists of a “pipe within a pipe”. Flue gas exits the building through the inner pipe and combustion air is drawn into the boiler through the space between the inner and outer pipe.
- **Horizontal (“Side Wall”) Twin Pipe Venting** - Vent system exits the building through an outside wall. Combustion air and flue gas are routed between the boiler and outdoors using separate pipes.
- **Vertical Concentric Venting** - Vent system exits the building through the roof. Concentric venting consists of a “pipe within a pipe”. Flue gas exits the building through the inner pipe and combustion air is drawn into the boiler through the space between the inner and outer pipe.
- **Vertical Twin Pipe Venting** - Vent system exits the building through a roof. Combustion air and flue gas are routed between the boiler and outdoors using separate pipes.

All of these systems are considered “direct vent” because in all of them air for combustion is drawn directly from the outdoors into the boiler. A description of all of these venting options are shown in Tables 7.1 and 7.9. For clarity, these vent options are numbered from 1 to 6. One of the vent option columns in Tables 7.1 or 7.9 must match the planned vent and air intake system exactly. In addition, observe the following guidelines:

- 1) **Approved vent systems** - Use only one of the approved vent systems shown in Tables 7.4 or 7.5. These vent systems fall into two basic categories:

- **Concentric Vent System** - The standard boiler is supplied with a concentric vent system having a maximum usable length of 25” (Figure 1.1). For longer runs, additional straight lengths and elbows are available from Crown. In some cases, larger diameter concentric pipe must be used. Each Crown concentric vent component consists of an inner pipe of polypropylene and the outer pipe of steel. Integral gaskets on each concentric fitting provide a gas tight seal. A list of all Crown concentric vent components is shown in Table 7.4.

In this manual, concentric pipe sizes are called out in terms of the inner and outer pipe nominal diameters in millimeters. For example, “60/100mm” pipe consists of a 60mm exhaust pipe inside a 100mm diameter outer pipe.

- **Twin Pipe Vent Systems** - Approved vent systems are made of a special stainless steel alloy (AL29-4C) for protection against corrosive flue gas condensate. They are designed to provide a gas tight seal at all joints and seams so that flue gas does not enter the building. Each approved vent system has a unique method for installation - **do not attempt to mix components from different vent systems**. A list of approved twin pipe vent systems is shown in Table 7.5. Note that a special vent collar (Crown PN 230510) is required if the boiler is to be vented with one of the approved stainless vent systems.

- 2) Maximum Vent and Air Intake Lengths - The maximum length of the vent air intake piping depends upon the vent option selected and the boiler size. See Table 7.1 or 7.9 for the maximum vent length. In horizontal vent systems, the lengths shown in Table 7.1 are in addition to the first standard elbow on top of the boiler. For vertical vent systems, the maximum vertical vent lengths shown in Table 7.9 are in addition to two standard radius elbows. If more elbows are desired, the maximum allowable vent length must be reduced by the amount shown in Table 7.8 for each additional elbow used. Termination fittings are never counted, although the length of the concentric terminal section is counted.

Example:

A 60/100mm concentric vent system is planned for a horizontally vented BWC120 which has the following components:

80/125 x 60/100mm Reducing Elbow (supplied with the boiler)

5ft Straight Pipe

90 elbow

1-1/2ft Straight Pipe

45Elbow

Uncut Terminal Section (supplied with the boiler)

The Vent Option #1 column in Table 7.1 describes a horizontal direct vent system using 60/100mm concentric vent pipe. From this column, we see that a BWC120 may have a vent length of up to 18ft. The 90 degree reducing elbow is not considered. The length of the terminal section (not including the plastic terminal itself) is approximately 22 1/2" (1.9ft) installed. From Table 7.8, we see that the equivalent length of the 60/100mm elbow is 4.5ft and that the equivalent length of the 45 degree elbow is 4ft. The total equivalent length of the planned venting system is therefore:

5ft (Straight) + 4.5ft (90 Elbow) + 1.5ft (Straight) + 4 ft (45 Elbow) + 1.9ft (Uncut Terminal Section) = 16.9ft.

Since Table 7.1 shows a maximum allowable vent length of 18ft, the planned vent system length is acceptable.

- 3) Minimum Vent and Air Intake Lengths - Observe the minimum vent lengths shown in tables 7.1 and 7.9.
- 4) Permitted Terminals for Horizontal Venting:
- **Vent Option 1** - The 60/100mm concentric vent terminal is supplied with the boiler as part of the standard vent system.
 - **Vent Option 2** - The exhaust terminal is Crown PN 230511. The air intake fitting is a 90 degree elbow with a rodent screen supplied by the installer. This elbow is made out of the same material as the rest of the air inlet system (either galvanized or PVC) and is installed as shown in Figure 7.3.
 - **Vent Option 3** - Two terminals are permitted:
 - a) 80/125mm Concentric Vent Terminal (Crown PN 230531)
 - b) 80/125mm Snorkel Terminal (Crown PN 230540) . This terminal allows the vent system to exit the building close to grade and go up the exterior wall far enough to provide adequate clearance between the terminal itself and the snow line (Figure 7.7).
- 5) Horizontal Vent and Air Intake Terminal Location - Observe the following limitations on the vent terminal location (also see Figures 7.6, 7.7). When locating a concentric terminal, observe the limitations outlined below for "vent terminals".
- Vent terminals must be at least 1 foot from any door, window, or gravity inlet into the building.
 - For twin pipe terminals, maintain the correct clearance and orientation between the vent and air intake terminals. The vent and air intake terminals must be at the same height and their center lines must be between 12 and 36 inches apart. Both terminals must be located on the same wall.
 - The bottom of all terminals must be at least 12" above the normal snow line. In no case should they be less than 12" above grade level.
 - The bottom of the vent terminal must be at least 7 feet above a public walkway.
 - Do not install the vent terminal directly over windows or doors.
 - The bottom of the vent terminal must be at least 3 feet above any forced air inlet located within 10 feet.
 - USA Only: A clearance of at least 4 feet horizontally must be maintained between the vent terminal and gas meters, electric meters, regulators, and relief equipment. Do not install vent terminal over this equipment. In Canada, refer to B149.1 Installation Code for clearance to meters, regulators and relief equipment.
 - Do not locate the vent terminal under decks or similar structures.
 - Top of vent terminal must be at least 5 feet below eaves, soffits, or overhangs. Maximum depth of overhang is 3 ft.

Horizontal Terminal Clearance Requirements (continued):

- Vent terminal must be at least 6 feet from an inside corner.
- Under certain conditions, water in the flue gas may condense, and possibly freeze, on objects around the vent terminal including on the structure itself. If these objects are subject to damage by flue gas condensate, they should be moved or protected.
- If possible, install the vent and air intake terminals on a wall away from the prevailing wind. Reliable operation of this boiler cannot be guaranteed if these terminals are subjected to winds in excess of 40 mph.
- Air intake terminal must not terminate in areas that might contain combustion air contaminants, such as near swimming pools. See Section IV for more information on possible contaminants.

TABLE 7.1: SUMMARY OF HORIZONTAL VENTING OPTIONS

VENT OPTION #		1	2	3	
CLASSIFICATION USED IN THIS MANUAL		HORIZONTAL CONCENTRIC	HORIZONTAL TWIN PIPE	HORIZONTAL CONCENTRIC	
ILLUSTRATED IN FIGURE		7.2	7.3	7.2	
VENT PIPE PENETRATION THROUGH STRUCTURE		WALL	WALL	WALL	
AIR INTAKE PIPE PENETRATION THROUGH STRUCTURE		WALL	WALL	WALL	
VENT PIPE SIZE		60/100 mm	3"	80/125 mm	
AIR INTAKE PIPE SIZE		CONCENTRIC	3"	CONCENTRIC	
MAXIMUM LENGTH	VENT	BWC070	32ft	100ft	100ft
		BWC090	32ft	100ft	100ft
		BWC120	18ft	100ft	100ft
		BWC151		100ft	100ft
	INLET	BWC070	32ft	100ft	100ft
		BWC090	32ft	100ft	100ft
		BWC120	18ft	100ft	100ft
		BWC151		100ft	100ft
MINIMUM LENGTH	VENT	BWC070	10in	10in	10in
		BWC090	10in	10in	10in
		BWC120	10in	10in	10in
		BWC151		10in	10in
	INLET	BWC070	10in	10in	10in
		BWC090	10in	10in	10in
		BWC120	10in	10in	10in
		BWC151		10in	10in
VENT TERMINAL		60/100 mm CONCENTRIC	CROWN #230511	Crown 230531 CONCENTRIC or 230540 SNORKEL	
AIR INTAKE TERMINAL			3" 90 ELBOW		
VENT MATERIAL		CROWN 60/100mm VENT COMPONENTS SHOWN IN TABLE 7.4a (Note #1)	APPROVED STAINLESS STEEL VENT SYSTEM SHOWN IN TABLE 7.5	CROWN 80/125mm VENT COMPONENTS SHOWN IN TABLE 7.4b	
AIR INTAKE MATERIAL			GALVANIZED OR PVC		

Note #1: In Vent Option #1, the 80/125mm concentric straight section (PN 230515) shown in Table 7.4a may be used between the boiler and the first 80/125 x 60/100 reducing elbow. If this is done, the overall maximum vent length is still restricted to that shown for Vent Option #1 in Table 7.1 above.

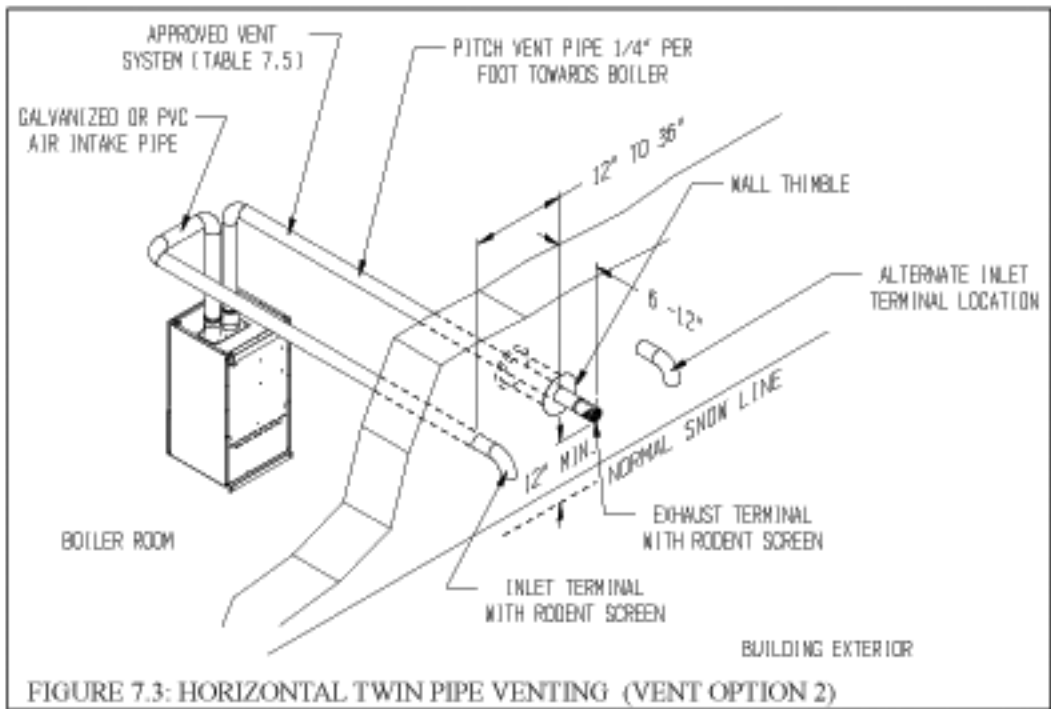
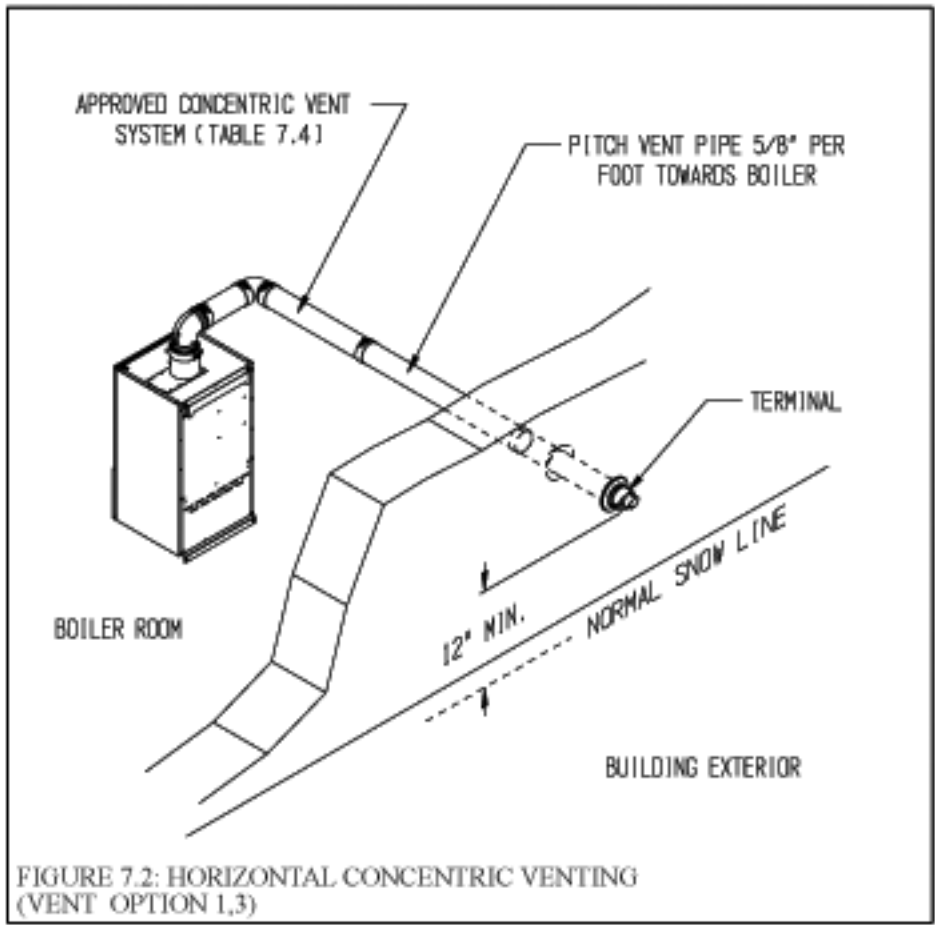

**TABLE 7.4a: CROWN CONCENTRIC 60/100 VENT COMPONENTS
(VENT OPTION 1)**

CROWN PN	DESCRIPTION	SIZE	USED ON VENT OPTION #	COMMENTS
230521	80/125 x 60/100mm REDUCING ELBOW	80/125 x 60/100mm	1	INCLUDED WITH STANDARD BWC070/090/120
230520	TERMINAL SECTION	60/100mm	1	INCLUDED WITH STANDARD BWC070/090/120
230522	WALL GROMMET	60/100mm	1	INCLUDED WITH STANDARD BWC070/090/120
230505	39" STRAIGHT	60/100mm	1	OPTIONAL - MAY NOT BE CUT
230504	78" STRAIGHT	60/100mm	1	OPTIONAL - MAY NOT BE CUT
230506	19 1/2" STRAIGHT	60/100mm	1	OPTIONAL - CAN BE CUT
230507	90 DEGREE ELBOW	60/100mm	1	OPTIONAL
230508	45 DEGREE ELBOW	60/100mm	1	OPTIONAL
230515	39" STRAIGHT	80/125mm	1	OPTIONAL - CAN BE CUT (Note #1)

Note #1: On 60/100mm vent systems, this may only be used between the boiler and the first 80/125 x 60/100 Reducing elbow (see text).

**TABLE 7.4b: CROWN CONCENTRIC 80/125 VENT COMPONENTS
(VENT OPTIONS 3,6)**

CROWN PN	DESCRIPTION	SIZE	USED ON VENT OPTION #	COMMENTS
230527	90 DEGREE EL (STANDARD)	80/125mm	3,6	
230528	90 DEGREE EL (SWEEP)	80/125mm	3,6	
230526	45 DEGREE EL	80/125mm	3,6	
230517	19 1/2" STRAIGHT	80/125mm	3,6	CAN BE CUT
230515	39" STRAIGHT	80/125mm	3,6	CAN BE CUT
230518	39" STRAIGHT	80/125mm	3,6	MAY NOT BE CUT
230519	78" STRAIGHT	80/125mm	3,6	MAY NOT BE CUT
230525	TELESCOPING STRAIGHT	80/125mm	3,6	ADJUSTABLE FROM 12-1/2" TO 16-1/2"
230531	HORIZONTAL TERMINAL	80/125mm	3	
230540	SNORKEL KIT	80/125mm	3	(NOTE #1)
230532	VERTICAL TERMINAL	80/125mm	6	(NOTE #2)
230533	FLAT ROOF FLASHING	80/125mm	6	
230535	SLOPED ROOF FLASHING	80/125mm	6	(NOTE #3)
230530	SUPPORT ELBOW WITH CHIMNEY CHASE BRACKET	80/125mm	6	(NOTE #4)
230536	SUPPORT BAND	80/125mm	3,6	

Table 7.4b Notes:

- 1) Snorkel kit includes parts needed to offset terminal on exterior wall by up to 46".
- 2) Vertical terminal can be used with either of the roof flashings listed beneath it.
- 3) Sloped roof flashing suitable for roof angles between 25 and 45 degrees.
- 4) Used at base of vertical run inside unused masonry chimney.

- 6) Permitted Terminals for Vertical Venting -
- **Vent Option 5** - A straight termination is installed in the end of the vent pipe. Vent manufacturer part numbers for these screens are shown in Table 7.5. The air inlet terminal consists of a 180 degree elbow (or two 90 degree elbows) with a rodent screen as shown in Figure 7.10.
 - **Vent Option 6** - Use Crown PN 230532 with the appropriate flashing (Table 7.4b)
- 7) Vertical Vent Terminal Locations (Vent Options 5,6) - Observe the following limitations on the location of all vertical vent terminals (see Figures 7.10, 7.11):
- The top of the vent pipe must be at least 2 feet above any object located within 10 feet.
 - For Vent Option #5, the vertical distance between top of the vent and air inlet terminal openings must be at least 12”.
 - The bottom of the air inlet terminal must be at least 12” above the normal snow accumulation that can be expected on the roof. The terminal used in Vent Option #6 has a fixed distance above the storm collar of 19”. If a greater distance is needed to provide the clearance above the snow line, build a chase on the roof and mount the vertical terminal on top of the chase.
 - For Vent Option #5, the air intake terminal must be located on the roof and must be no further than 24” horizontally from the exhaust pipe.
- 8) Wall thimbles – Wall thimbles are required where single wall vent pipe passes through combustible walls with less than the required clearance shown in Table 4.2 or as required by local codes. Stainless vent manufacturer’s wall thimble part numbers are shown in Table 7.5. Note that concentric vent has a “zero” clearance to combustibles and therefore does not require the use of wall thimbles.

**TABLE 7.5: PERMISSIBLE STAINLESS STEEL VENT SYSTEMS
AND PRINCIPLE VENT COMPONENTS
(VENT OPTIONS 2, 5)**

MANUFACTURER	VENT SYSTEM	SIZE	COMPONENT	PART NUMBER
HEAT FAB	SAF-T VENT EZ SEAL	3	BOILER COLLAR	CROWN 230510
		3	WALL THIMBLE	HEAT FAB 7393, 7393GCS, 5391CI
		3	HORIZONTAL TERMINAL	CROWN 230511
		3	VERTICAL TERMINAL	HEAT FAB 9392
PROTECH SYSTEMS INC.	FASNSEAL	3	BOILER COLLAR	CROWN 230510
		3	WALL THIMBLE	FSWT3
		3	HORIZONTAL TERMINAL	CROWN 230511
		3	VERTICAL TERMINAL	FSBS3
Z-FLEX	SVE SERIES III (“Z-VENT III”)	3	BOILER COLLAR	CROWN 230510
		3	WALL THIMBLE	2SVSWTEF03
		3	HORIZONTAL TERMINAL	CROWN 230511
		3	VERTICAL TERMINAL	24SVSTPF03
METAL-FAB	CORR/GUARD	3	BOILER COLLAR	CROWN 230510
		3	WALL THIMBLE	CGSWWPK(3”)
		3	HORIZONTAL TERMINAL	CROWN 230511
		3	VERTICAL TERMINAL	CGSWHTM(3”)

NOTES:

- 1) See vent system manufacturer’s literature for other part numbers that are required such as straight pipe, elbows, firestops and vent supports.
- 2) Crown 230510 collar replaces factory-mounted concentric collar (Figure 7.16).

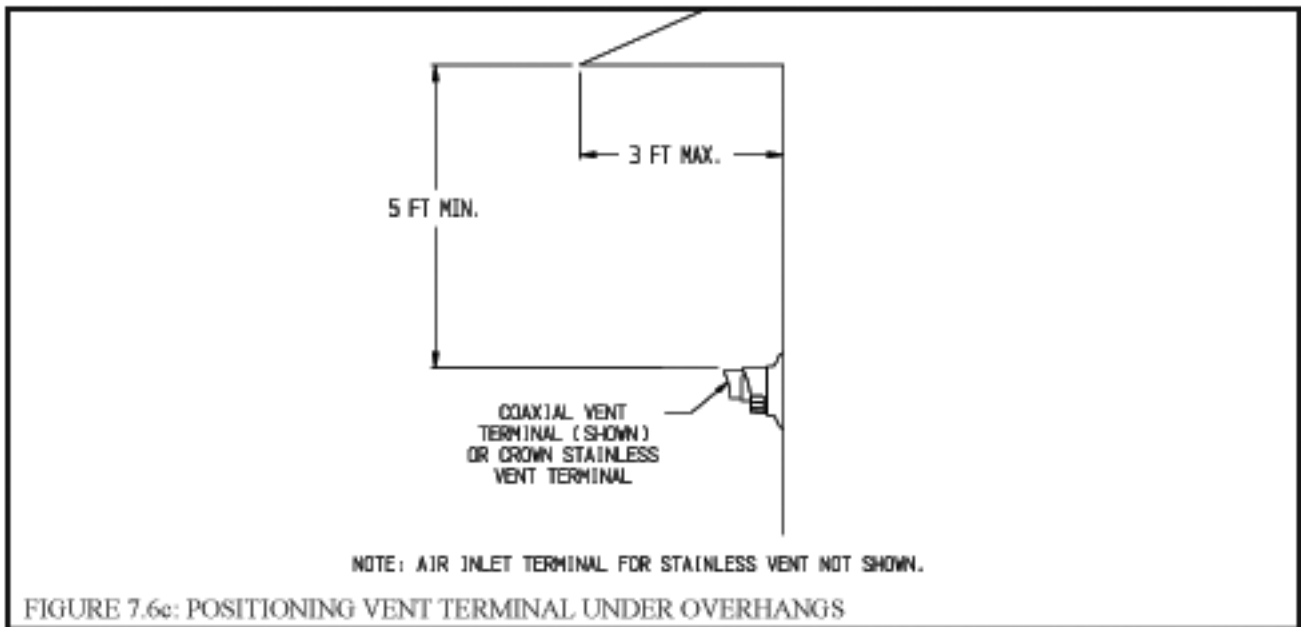
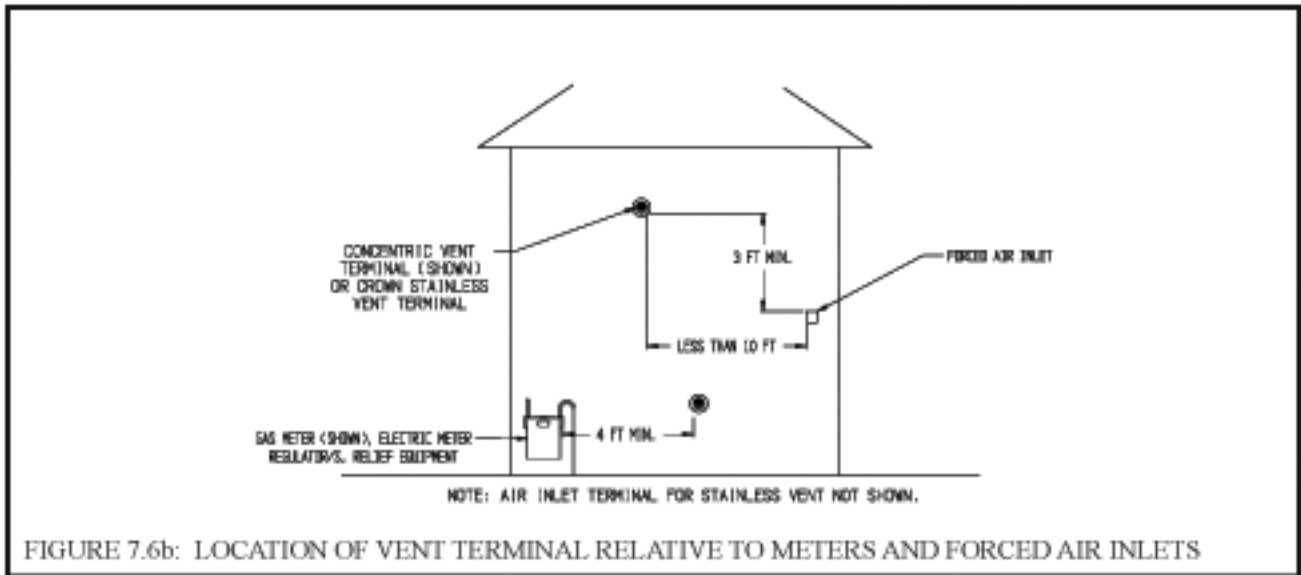
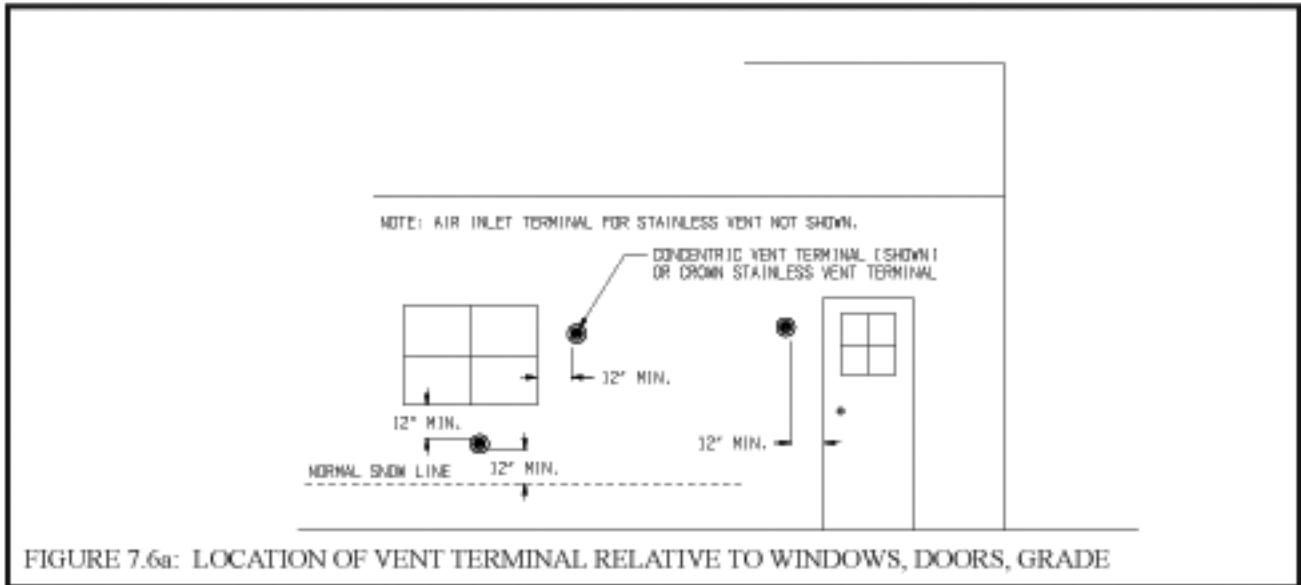

9) Pitch of Horizontal Piping - Pitch all horizontal piping so that any condensate which forms in the piping will run towards the boiler:

- Pitch Crown horizontal concentric venting 5/8" per foot
- Pitch Stainless steel venting 1/4" per foot.

10) Supporting Pipe - Vertical and horizontal sections of pipe must be properly supported:

- Support Crown concentric venting near the female end of each straight section of pipe.

Exception: Vertical runs of concentric pipe in an unused chimney (Figure 7.36) need only be supported at the terminal and at the base of the run.

- Support stainless steel venting as called for by the vent manufacturer's instructions.

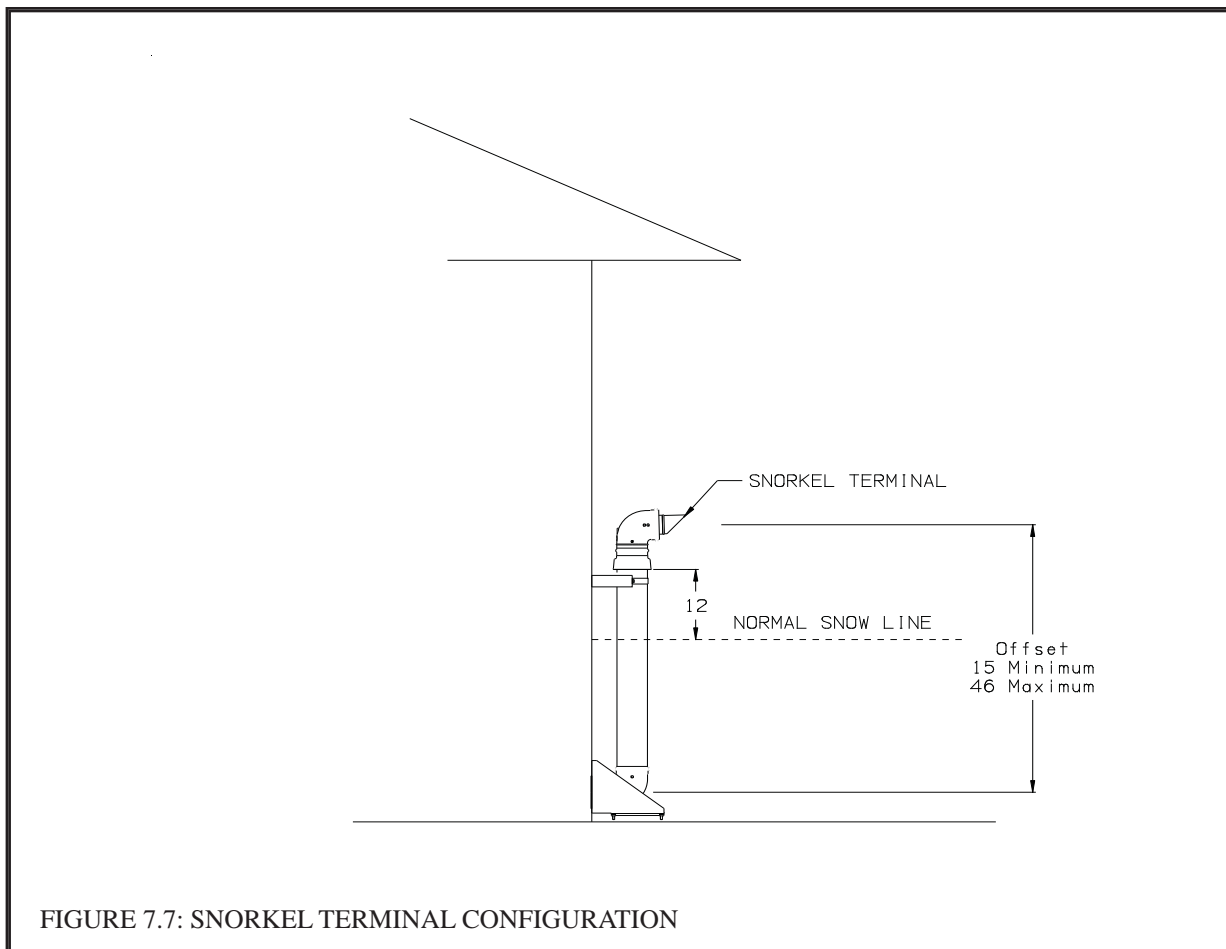

TABLE 7.8: VENT/ AIR INTAKE FITTING EQUIVALENT LENGTH

VENT FITTING	EQUIVALENT LENGTH (ft)
60/100mm 90° CONCENTRIC ELBOW	4.5
60/100mm 45° CONCENTRIC ELBOW	4.0
80/125mm 90° CONCENTRIC ELBOW	8.5
80/125mm 90° SWEEP CONCENTRIC ELBOW	5.5
80/125mm 45° CONCENTRIC ELBOW	3.0
80/125mm 90° CONCENTRIC SUPPORT ELBOW	8.5
3" SINGLE WALL 90° ELBOW	5.5
3" SINGLE WALL 45° ELBOW	4.0

TABLE 7.9: SUMMARY OF VERTICAL VENTING OPTIONS

VENT OPTION #		5	6	
CLASSIFICATION USED IN THIS MANUAL		VERTICAL TWIN PIPE	VERTICAL CONCENTRIC	
ILLUSTRATED IN FIGURE		7.10	7.11	
VENT PIPE PENETRATION THROUGH STRUCTURE		ROOF	ROOF	
AIR INTAKE PIPE STRUCTURE THROUGH STRUCTURE		ROOF	ROOF	
VENT PIPE SIZE		3"	80/125 mm CONCENTRIC	
AIR INTAKE PIPE SIZE		3"		
MAXIMUM LENGTH	VENT	BWC070	98ft	95ft
		BWC090	98ft	95ft
		BWC120	98ft	95ft
		BWC151	98ft	95ft
	INLET	BWC070	98ft	95ft
		BWC090	98ft	95ft
		BWC120	98ft	95ft
		BWC151	98ft	95ft
MINIMUM LENGTH	VENT	BWC070	2ft	2ft
		BWC090	2ft	2ft
		BWC120	2ft	2ft
		BWC151	2ft	2ft
	INLET	BWC070	2ft	2ft
		BWC090	2ft	2ft
		BWC120	2ft	2ft
		BWC151	2ft	2ft
VENT TERMINAL		STRAIGHT TERMINAL BY VENT SYSTEM MFR. (TABLE 7.5)	CROWN #230532 CONCENTRIC TERMINAL (TABLE 7.4b)	
AIR INTAKE TERMINAL		3" 180° ELBOW (FIGURE 7.10)		
VENT MATERIAL		APPROVED STAINLESS STEEL VENT SYSTEM	CROWN 80/125 mm VENT COMPONENTS SHOWN IN TABLE 7.4b	
AIR INTAKE MATERIAL		GALVANIZED OR PVC		

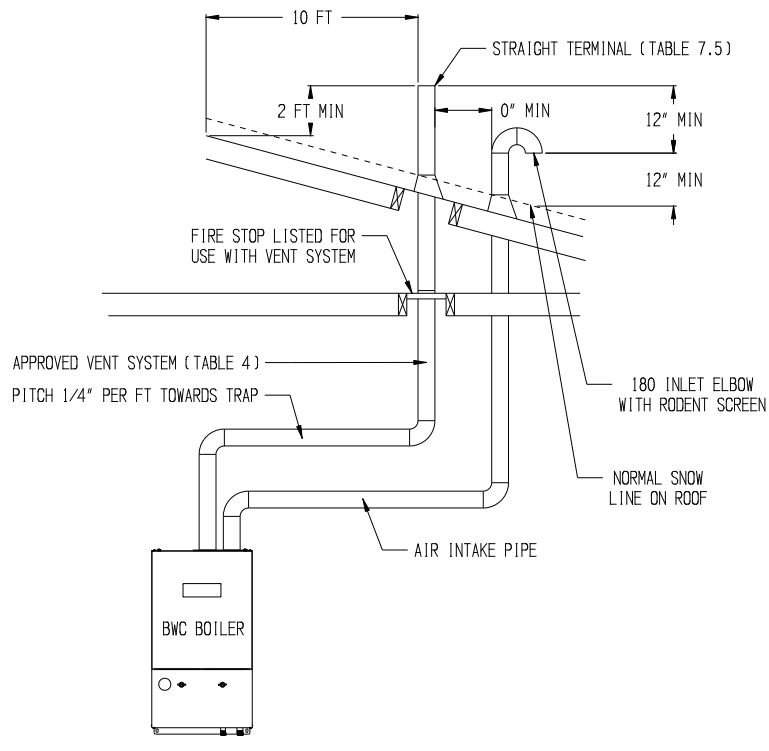

FIGURE 7.10: VERTICAL TWIN PIPE VENT SYSTEM (VENT OPTION 5)

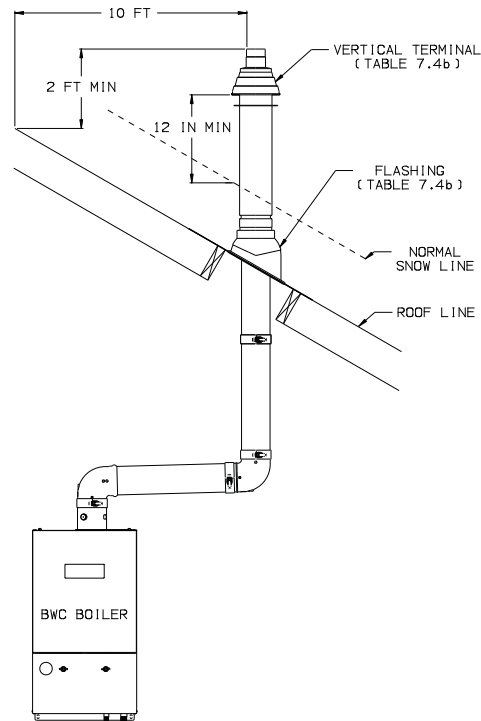

FIGURE 7.11: VERTICAL CONCENTRIC VENT SYSTEM (VENT OPTION 6)

B. Removing an Existing Boiler From a Common Chimney

Read this only if the BWC boiler is replacing an existing boiler that is being removed from a common chimney. This section does not apply to the installation of a BWC boiler.

In some cases, when an existing boiler is removed from a common chimney, the common venting system may be too large for the remaining appliances. At the time of removal of an existing boiler, the following steps shall be followed with each appliance remaining connected to the common venting system placed in operation, while the other appliances remaining connected to the common venting system are not in operation.

- (a) Seal any unused openings in the common venting system.
- (b) Visually inspect the venting system for proper size and horizontal pitch and determine there is no blockage or restriction, leakage, corrosion and other deficiencies which could cause an unsafe condition.
- (c) Insofar as practical, close all building doors and windows and all doors between the space in which all the appliances remaining connected to the common venting system are located and other spaces of the building. Turn on clothes dryers and any appliance not connected to the common venting system. Turn on any exhaust fans, such as range hoods and bathroom exhausts, so they will operate at maximum speed. Do not operate a summer exhaust fan. Close fireplace dampers.
- (d) Place in operation the appliance being inspected. Follow the lighting instructions. Adjust thermostat so the appliance will operate continuously.
- (e) Test for spillage at the draft hood relief opening after 5 minutes of main burner operation. Use the flame of a match or candle, or smoke from a cigarette, cigar, or pipe.
- (f) After it has been determined that each appliance remaining connected to the common venting system properly vents when tested as outlined above, return doors, windows, exhaust fans, fireplace dampers and any other gas-burning appliances to their previous condition of use.
- (g) Any improper operation of the common venting system should be corrected so the installation conforms with the National Fuel Gas Code, ANSI Z223.1. When re-sizing any portion of the common venting system, the common venting system should be re sized to approach the minimum size as determined using the appropriate tables in Part 11 of the National Fuel Gas Code, ANSI Z223.1.

WARNING

NEVER COMMON VENT A BWC BOILER WITH OTHER APPLIANCES.

C. Assembly of Crown 60/100mm Concentric Venting

(IMPORTANT - Skip to Section D for 80/125mm Concentric Vent Assembly)

WARNING

Failure to follow the instructions could result in flue gas leakage into the combustion air or indoor air, resulting in unsafe or unreliable operation.

- **Do not lubricate concentric gaskets with anything other than water.**
- **Do not attempt to cut any piping except as permitted in this section. When cutting these sections, make sure all cuts are square and allow for proper insertion.**
- **Do not attempt to try to mix this concentric pipe with other venting systems.**

- 1) Concentric vent components supplied with the boiler are packed inside the BWC070/090/120 carton and include the following:
 - a) 80/125 x 60/100mm reducing elbow (Crown PN 230521).
 - b) 60/100mm terminal section (straight section with a terminal and overall length of 27 3/4" (Crown PN 230520).
 - c) Two (2) Rubber wall grommets (Crown PN 230522).
- 2) Unless the 80/125 straight riser (PN 230515) is used, start by attaching the reducing elbow to the boiler collar. To do so, remove the clamp from the large end of the reducing elbow and set aside. Apply a small amount of water to the brown gasket on the boiler collar. Push the elbow onto the boiler collar until the bead on the elbow contacts the top edge of the collar (Figure 7.20).
- 3) Reinstall the clamp removed in Step (2) so that the elbow is secured to the boiler collar.
- 4) If no additional sections of concentric pipe are required, attach the terminal section to the elbow. In most cases, it will need to be cut before doing so. Use the following procedure to cut the pipe:
 - a) Measure distance "L" from the outside surface of the exterior wall to the end of the elbow as shown in Figure 7.21.
 - b) Add 2-1/8" to distance "L". Carefully mark this length on the pipe as shown in Figure 7.22.
 - c) Press in the two tabs holding the plastic terminal in the terminal section (Figure 7.22). Carefully pull out the terminal and the inner pipe.
 - d) Cut the **outer pipe only** at the point marked in Step (b) using aviation shears, a hacksaw, or an abrasive wheel cutter. Be careful to cut the pipe square. De burr the cut end with a file or emery cloth.
 - e) Cut the plastic inner pipe so that it will protrude 3/8" beyond the outer pipe when reinstalled in the terminal section (Figure 7.23). Use a fine tooth hacksaw or a PVC saw to cut the plastic pipe and be careful to cut the pipe square. De burr the cut edge of the plastic pipe with a file, razor blade, or fine sandpaper.
 - f) Reinstall the inner pipe in the terminal section. Slip the outside wall grommet over the terminal section and position so that it covers the joint between the outer pipe and the terminal (Figure 7.24).
 - g) Make a mark on the terminal section 1" from the cut end of the outer pipe as shown in Figure 7.24.
 - h) Pass the terminal section through the wall from the outside. Push the remaining wall grommet over the terminal section on the inside of the wall. Push the terminal section into the elbow until the mark made in Step (g) is no longer visible. If necessary, the brown gasket in the inner pipe may be lubricated with a few drops of water.
 - i) The terminal section must be attached to the elbow with a single #10 x 1/2" sheet metal screw (not supplied) at the top of the elbow. Drill a 1/8" hole in the location shown in Figure 7.25. **Use a short drill bit or a drill stop to ensure that the drill bit does not penetrate the pipe by more than 3/8"**. Install a #10 x 1/2" screw in this hole. **Do not use a screw longer than 1/2" long.**
 - j) If not already done, make sure that both wall grommets are firmly against the interior and exterior wall surfaces. Seal any cracks or other openings near the terminal through which exhaust could enter the building.
- 5) If additional pieces of pipe are used, install them starting at the boiler elbow. Support each section of straight pipe at its female end.

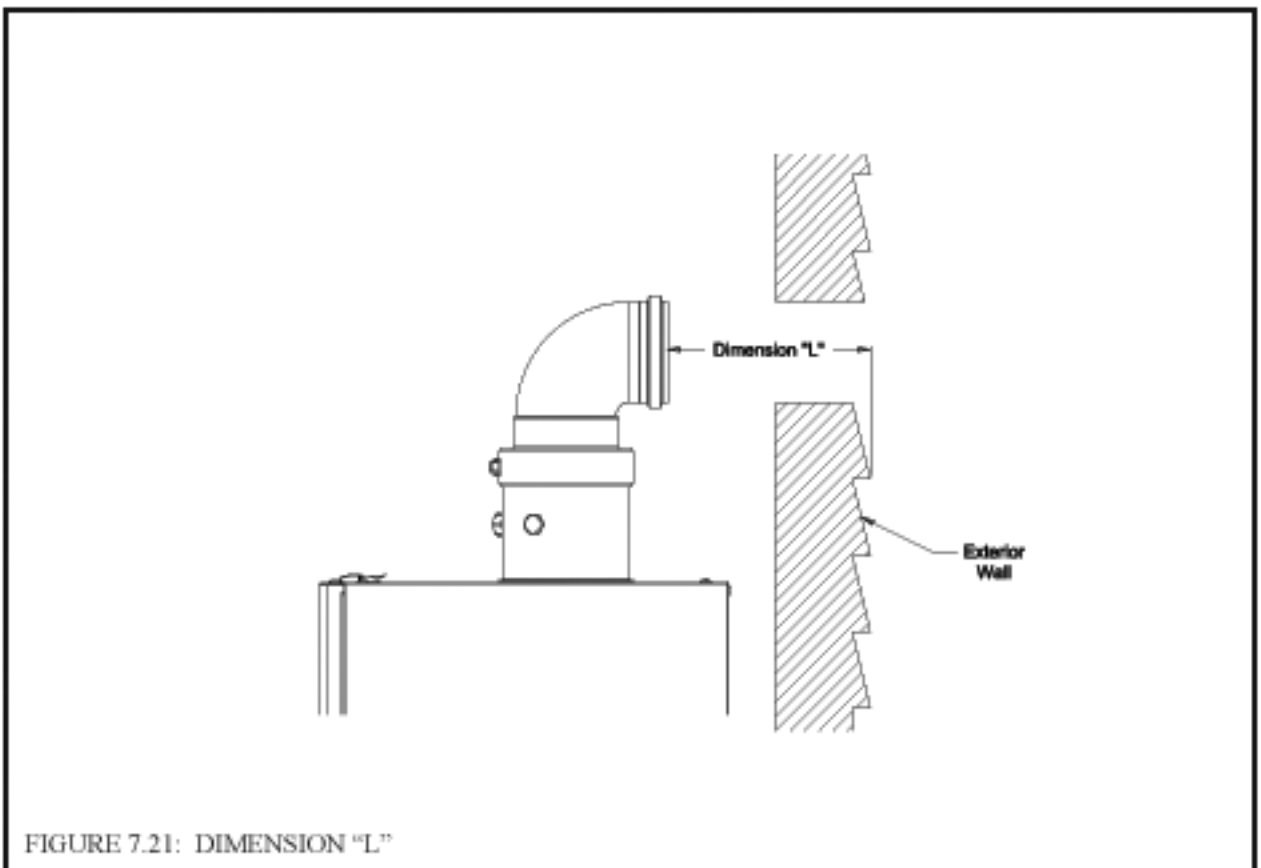
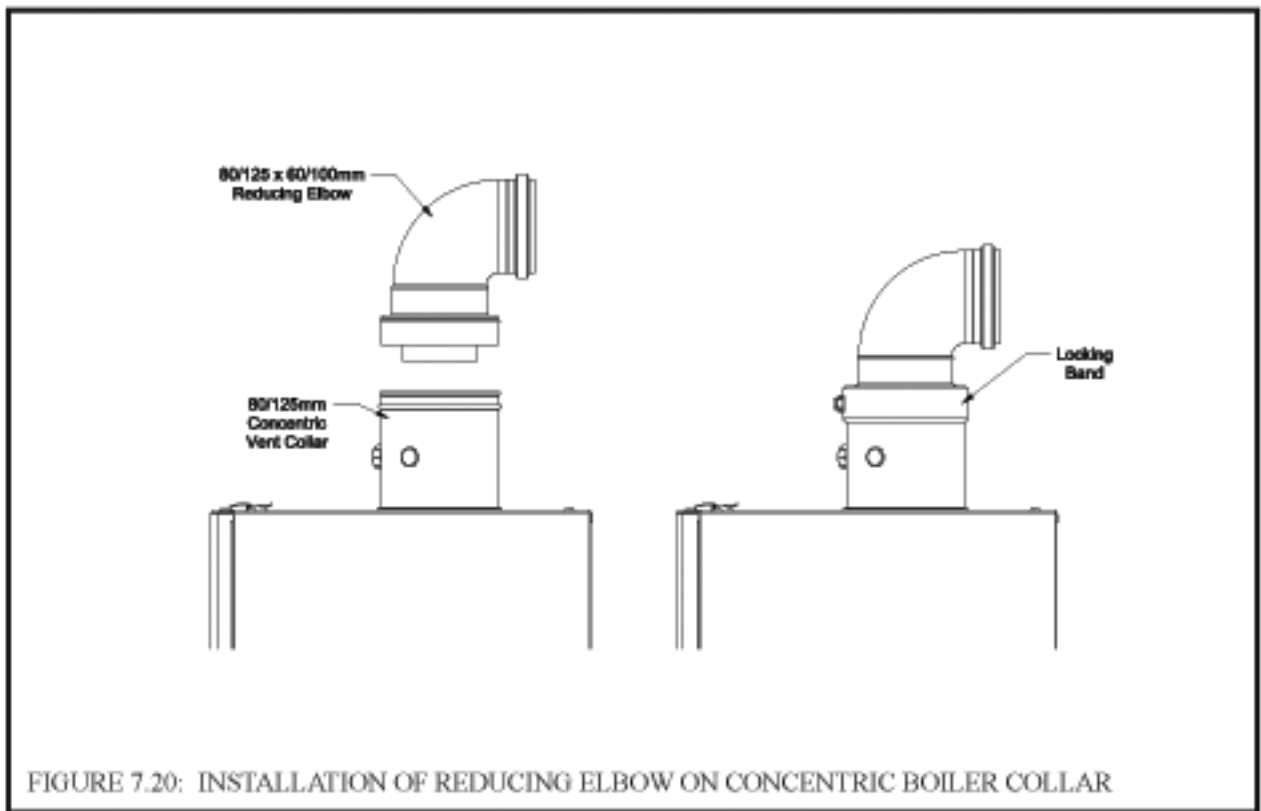

- 6) Use locking bands provided to join adjacent sections of non-cuttible pipe as well as fittings. The male end of the terminal section and other cuttable sections must be held to the female end of the adjoining pipe with at least three #10 x 1/2" sheet metal screws. Drill a 1/8 hole through both outer pipes to start this screw. **Use a drill stop or other means to ensure that the drill bit does not penetrate more than 3/8" into the outer pipe. Do not use a sheet metal screw longer than 1/2".**
- 7) The only straight pipe that can be cut is the terminal section, the 19-1/2" section (Crown PN 230506) and the 80/125 straight riser (PN230515). To cut this pipe:
- Cut pipe from the male end. After marking the desired length of the outer pipe, remove the plastic inner pipe by pulling it out from the female end.
 - Cut the **outer pipe only** at the point marked in Step (b) using aviation shears, a hacksaw, or an abrasive wheel cutter. Be careful to cut the pipe square. De burr the cut end with a file or emery cloth.
 - Cut the plastic inner pipe so that it will protrude 3/8" beyond the outer pipe when reinstalled in the outer pipe. Use a fine tooth hacksaw or a PVC saw to cut the plastic pipe and be careful to cut the pipe square. De burr the cut edge of the plastic pipe with a file, razor blade, or fine sandpaper.
 - Reinstall the inner pipe.
- 8) Install the terminal as outlined in Step (4) above. Dimension "L" described in Step 4 is the distance from the exterior surface of the wall to the end of the last piece of pipe inside the building.

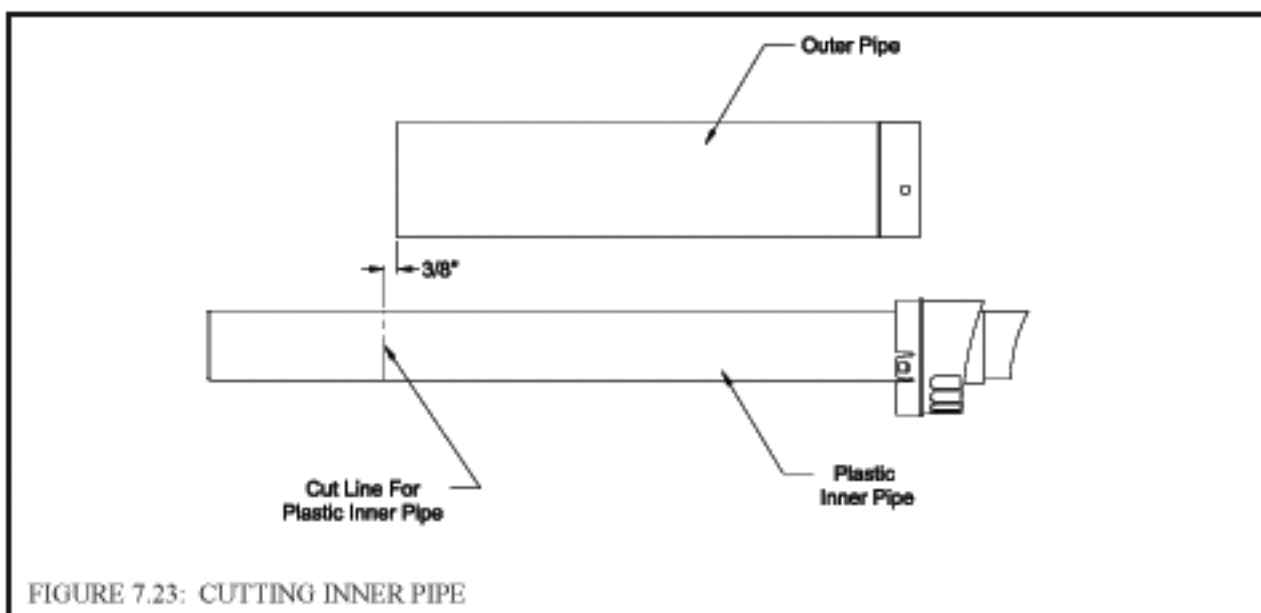
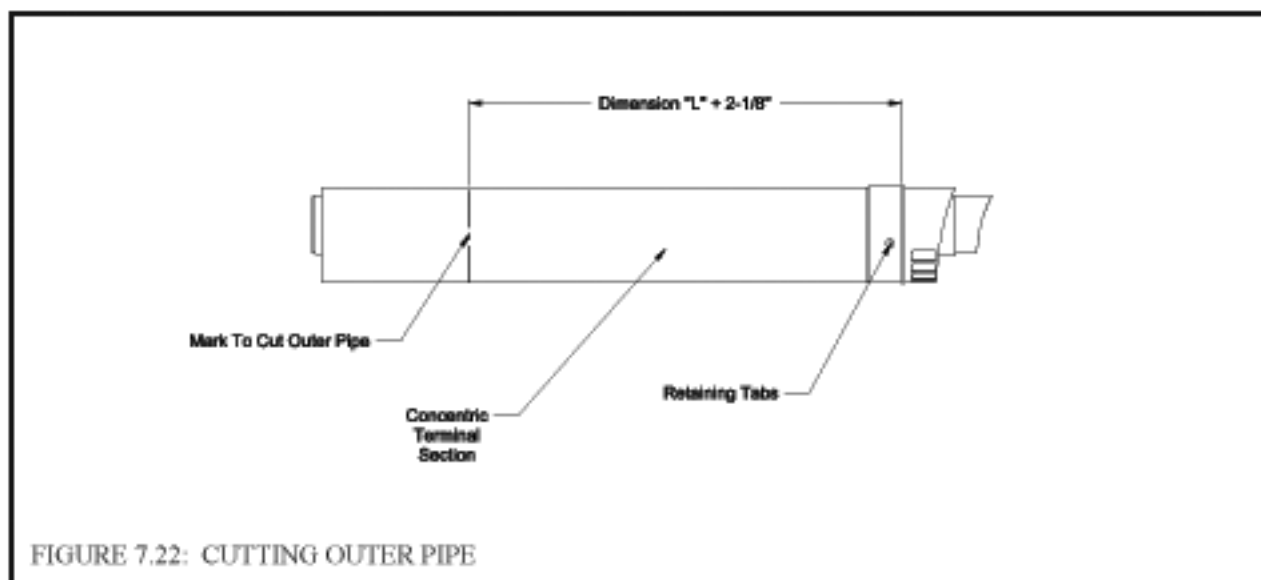

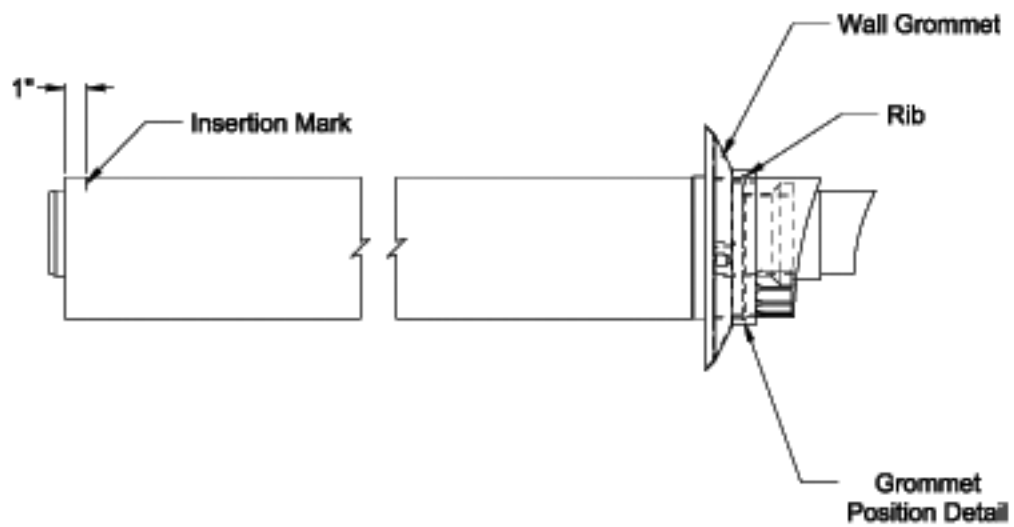

FIGURE 7.24: PREPARING 60/100mm TERMINAL SECTION FOR INSTALLATION IN THE WALL

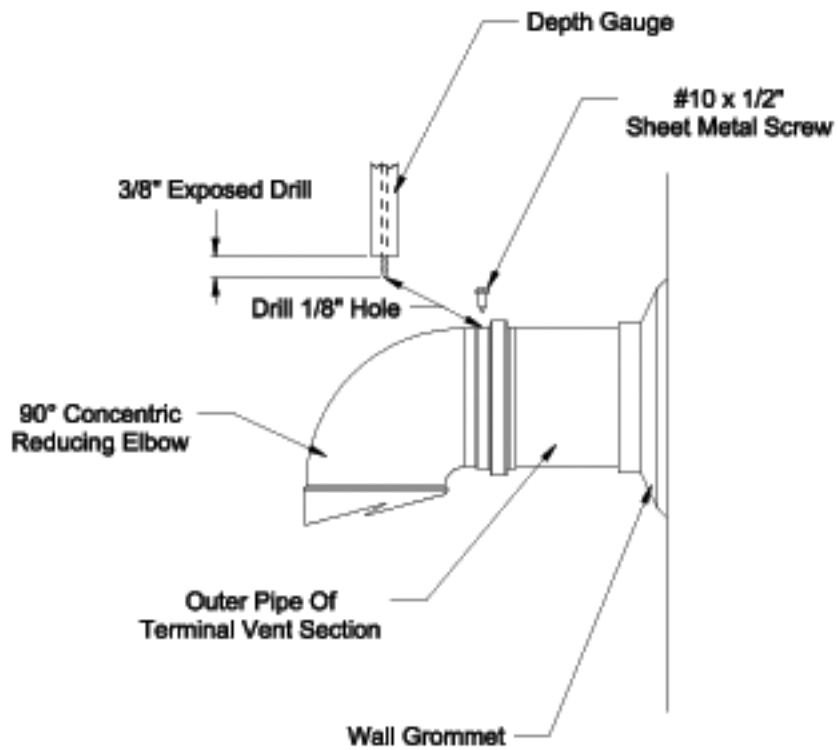

FIGURE 7.25: ATTACHING 60/100mm TERMINAL SECTION

D. Assembly of Crown 80/125mm Concentric Venting
(IMPORTANT - See Section C for 60/100mm Concentric Vent Assembly)

WARNING

Failure to follow the instructions could result in flue gas leakage into the combustion air or indoor air, resulting in unsafe or unreliable operation.

- Do not lubricate concentric gaskets with anything other than water.
- Do not attempt to cut any piping except as permitted in this section. When cutting these sections, make sure all cuts are square and allow for proper insertion.
- Do not attempt to try to mix this concentric pipe with other venting systems.

1) When BWC070, BWC090, or BWC120 boilers are vented using 80/125 venting, the 60/100 terminal section and reducing elbow supplied with the boiler are not used. The components listed in Table 7.4b are required for 80/125mm installations and are not supplied.

The BWC151 is supplied with the following 80/125 components:

- 80/125 Standard Radius Elbow
- 80/125 Terminal Section

Before starting assembly of an 80/125 vent system, make sure that the planned installation is in accordance with the “Vent System Design” Section of this manual and that all required 80/125mm vent components are on hand. Any components not supplied with the boiler are available through Crown distributors.

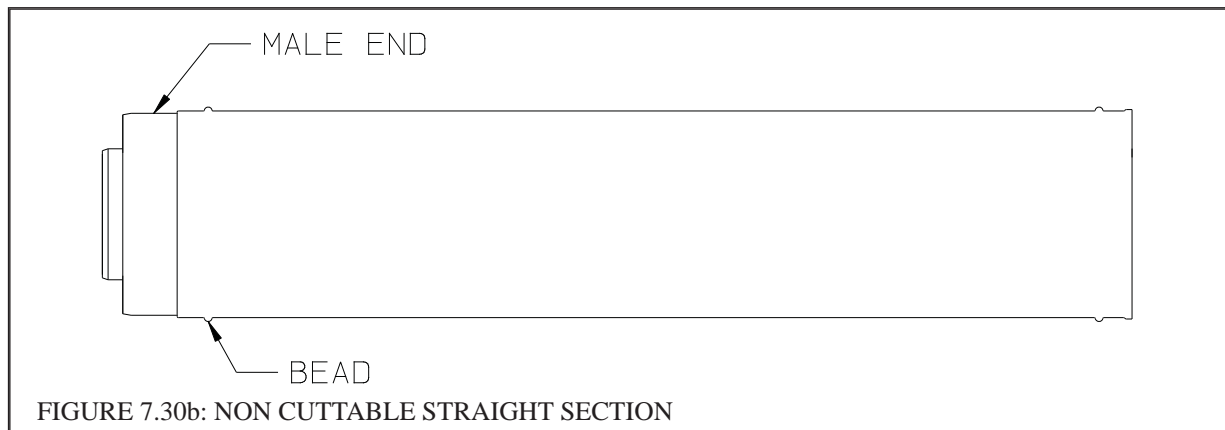
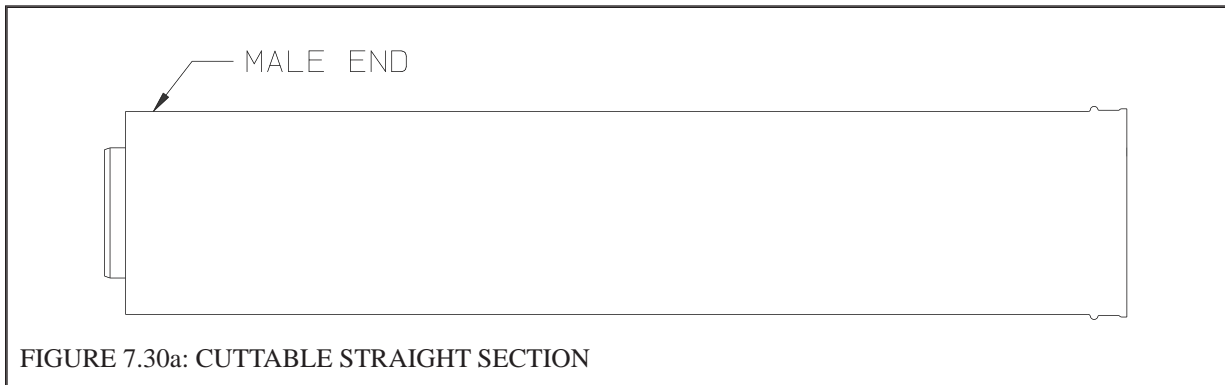

2) Cutting Straight Pipe - The following straight pipe sections may be cut:

Part #	Description
230517	19 1/2" Straight
230515	39" Straight

These sections have a plain male end (without beads - see Figure 7.30a). They are always cut from the male end. Sections not shown on the above list may not be cut. These sections have beads on the male end (Figure 7.30b).

To cut the straight sections listed above refer to Figure 7.31 and the following instructions:

- Determine the required length of the outer pipe. When doing this allow an additional 1" of length for insertion into the female end of the adjoining pipe. Mark the cut line on the outer pipe.
- Remove the plastic inner pipe by pulling it out from the female end.
- Cut the **OUTER PIPE ONLY** at the point marked in Step (a) using aviation shears, a hacksaw, or an abrasive wheel cutter. Be careful to cut the pipe square. De burr the cut end with a file or emery cloth.
- Make an insertion mark 1" from the male end of the outer pipe.
- Cut the plastic inner pipe so that it will protrude 3/8" beyond the male end of the outer pipe when reinstalled in the outer pipe. Use a fine tooth hacksaw or a PVC saw to cut the plastic pipe and be careful to cut the pipe square. De burr the cut edge of the plastic pipe with a file, razor blade, or fine sandpaper.
- Reinstall the inner pipe.

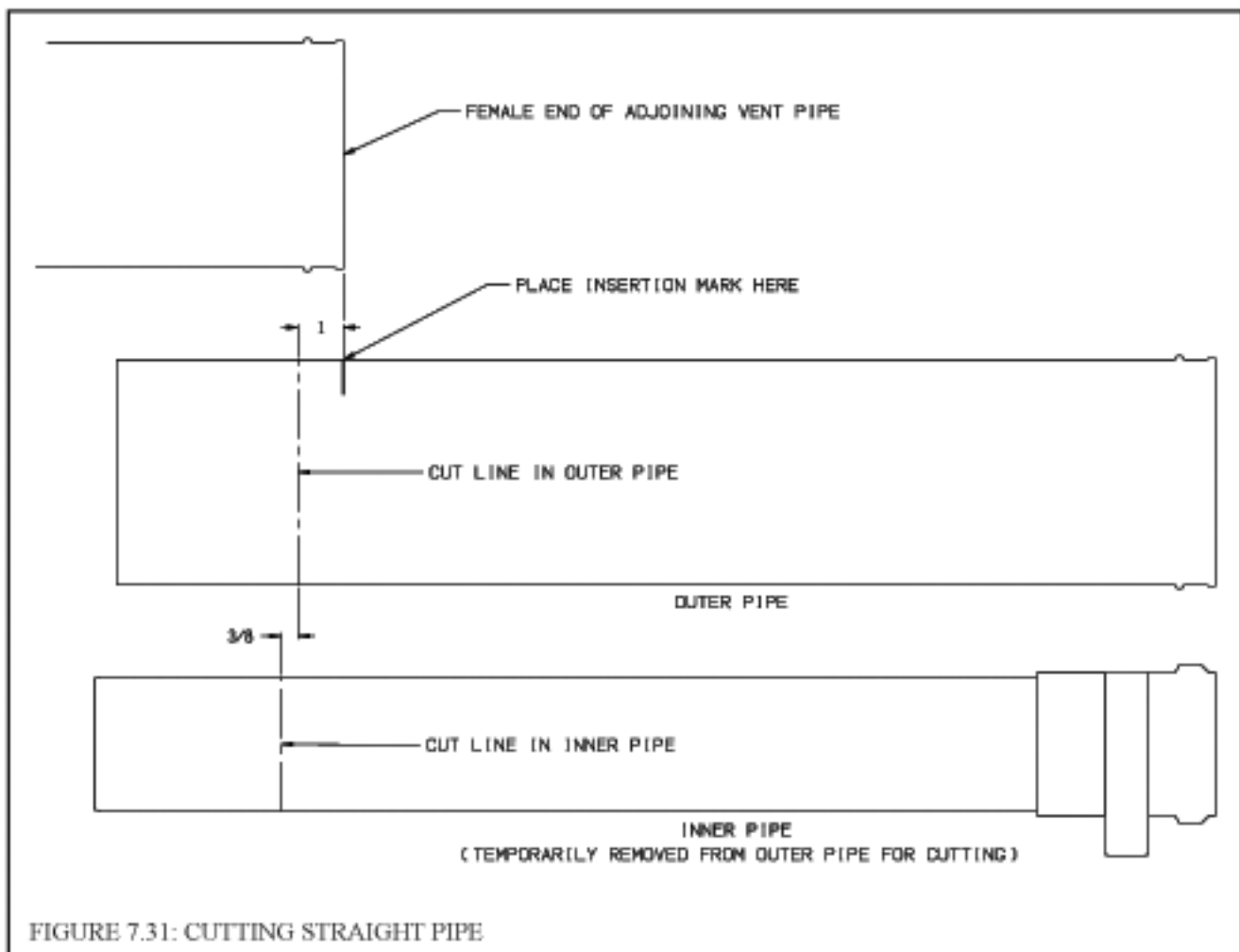
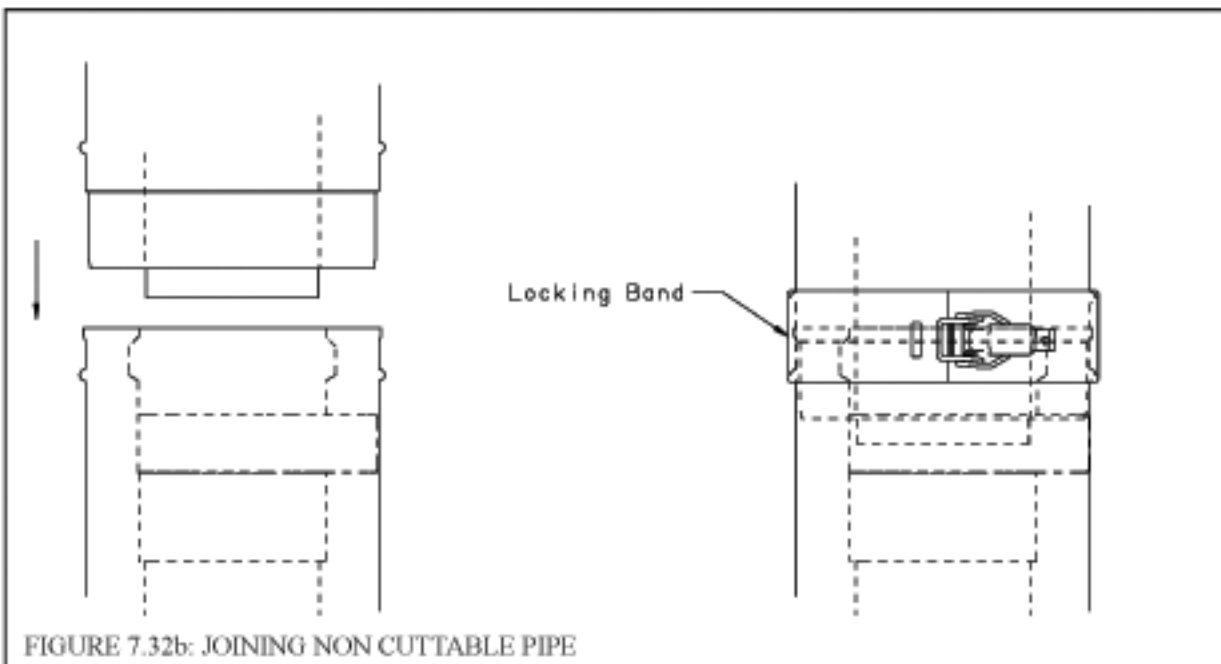
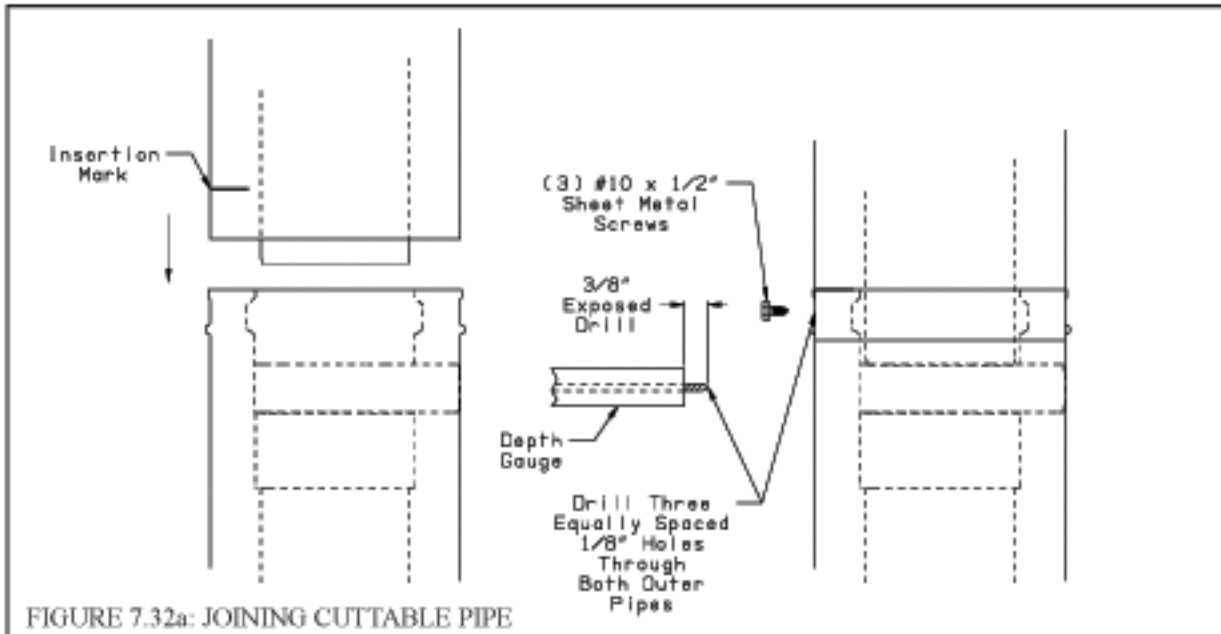

FIGURE 7.31: CUTTING STRAIGHT PIPE

3) Joining Pipe -

- a) Start assembly of the vent system at the boiler. Lubricate the brown gasket in the boiler vent collar with a few drops of water.
- b) Push the male end of the first fitting into the boiler collar until it bottoms out. The male end of cuttable sections should go 1" into the collar until the insertion mark (made in Step 2d above) is covered. On other fittings, the bead on the male pipe will bottom out on the collar (Figure 7.32b).
- c) The male end of cuttable fittings must be held to the collar with three #10 x 1/2" sheet metal screws. Drill a 1/8 hole through both outer pipes to start this screw. **Use a drill stop or other means to ensure that the drill bit does not penetrate more than 3/8" into the outer pipe. Do not use a sheet metal screw longer than 1/2"** (Figure 7.32a).
- d) Use locking bands (provided with all fittings) to secure non-cuttable pipe, as well as fittings, to the boiler collar (Figure 7.32b).
- e) Use the same method to join all remaining vent components except for the terminal.



4) 80/125mm Horizontal Terminal Installation -

- a) Cut a 5-1/2" diameter hole through the exterior wall at the planned location of the horizontal terminal.
- b) Measure distance "L" from the outside surface of the exterior wall to the end of the last fitting as shown in Figure 7.33a.
- c) Add 1-1/4" to distance "L". Carefully mark this length on the pipe as shown in Figure 7.33b.
- d) Remove the plastic inner pipe from the terminal, by gently pulling on it from the male end. Set aside.
- e) Cut the **outer pipe only** at the point marked in Step (c) using aviation shears, a hacksaw, or an abrasive wheel cutter. Be careful to cut the pipe square. De-burr the cut end with a file or emery cloth.
- f) Reinstall the plastic inner pipe in the terminal, making sure that the female end of this pipe is completely bottomed out over the aluminum male connection visible behind the air intake grill. Place a mark on the plastic inner pipe 3/8" beyond the end of the outer pipe (Figure 7.33c). Use a fine tooth hacksaw or a PVC saw to cut the plastic pipe and be careful to cut the pipe square (if necessary, the plastic pipe can be removed from the terminal again for cutting). De-burr the cut edge of the plastic pipe with a file, razor blade, or fine sandpaper.
- g) Make a mark on the terminal section 1" from the cut end of the outer pipe as shown in Figure 7.33c.
- h) Slip the terminal section through the wall from the outside. Pass the terminal through the inner wall plate and push into the last section of vent pipe until the mark made in Step (h) is not longer visible (Figure 7.33d). Secure the terminal to the last piece of pipe with three #10 x 1/2" sheet metal screws. Drill a 1/8" hole through both outer pipes to start these screws. **Use a drill stop or other means to ensure that the drill bit does not penetrate more than 3/8" into the outer pipe. Do not use a sheet metal screw longer than 1/2".**
- i) Slip the outer wall plate over the terminal and secure to the wall (Figure 7.33d). Apply a 1/8" bead of weather resistant RTV over the joint between the outside wall plate and the terminal. Secure the other wall

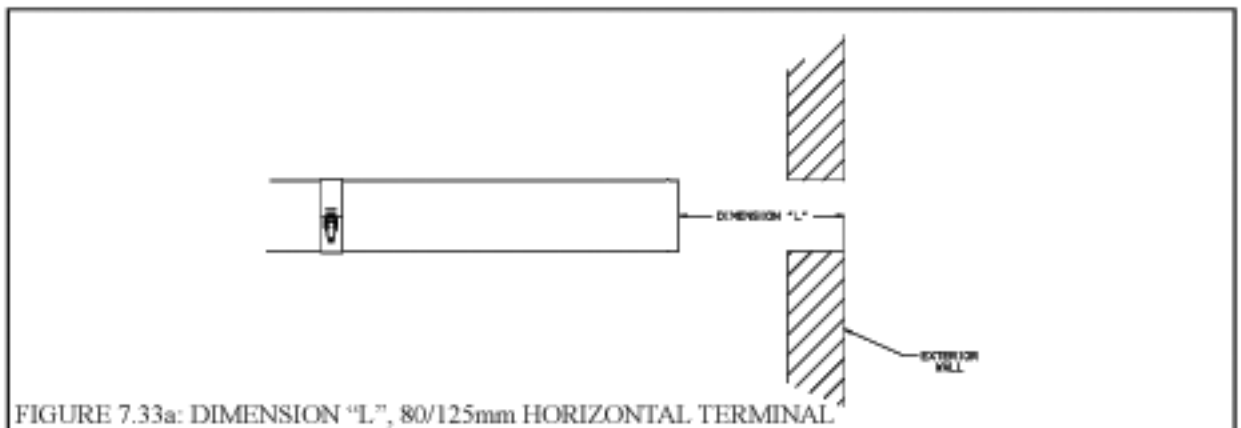

FIGURE 7.33a: DIMENSION "L", 80/125mm HORIZONTAL TERMINAL.

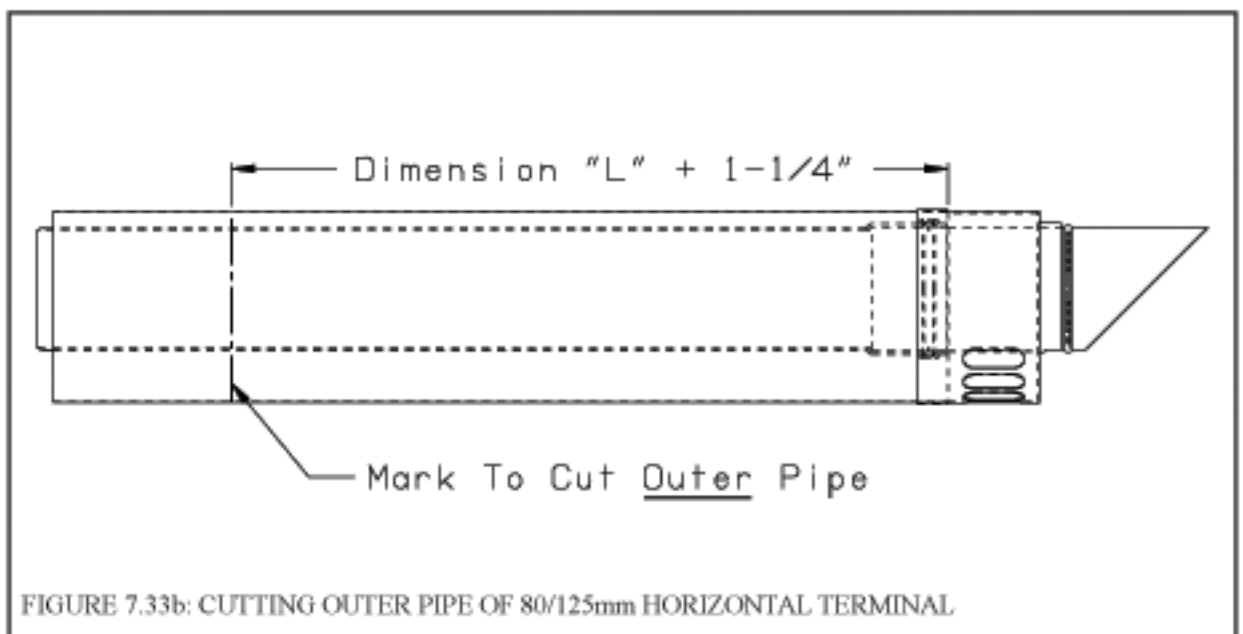

FIGURE 7.33b: CUTTING OUTER PIPE OF 80/125mm HORIZONTAL TERMINAL.

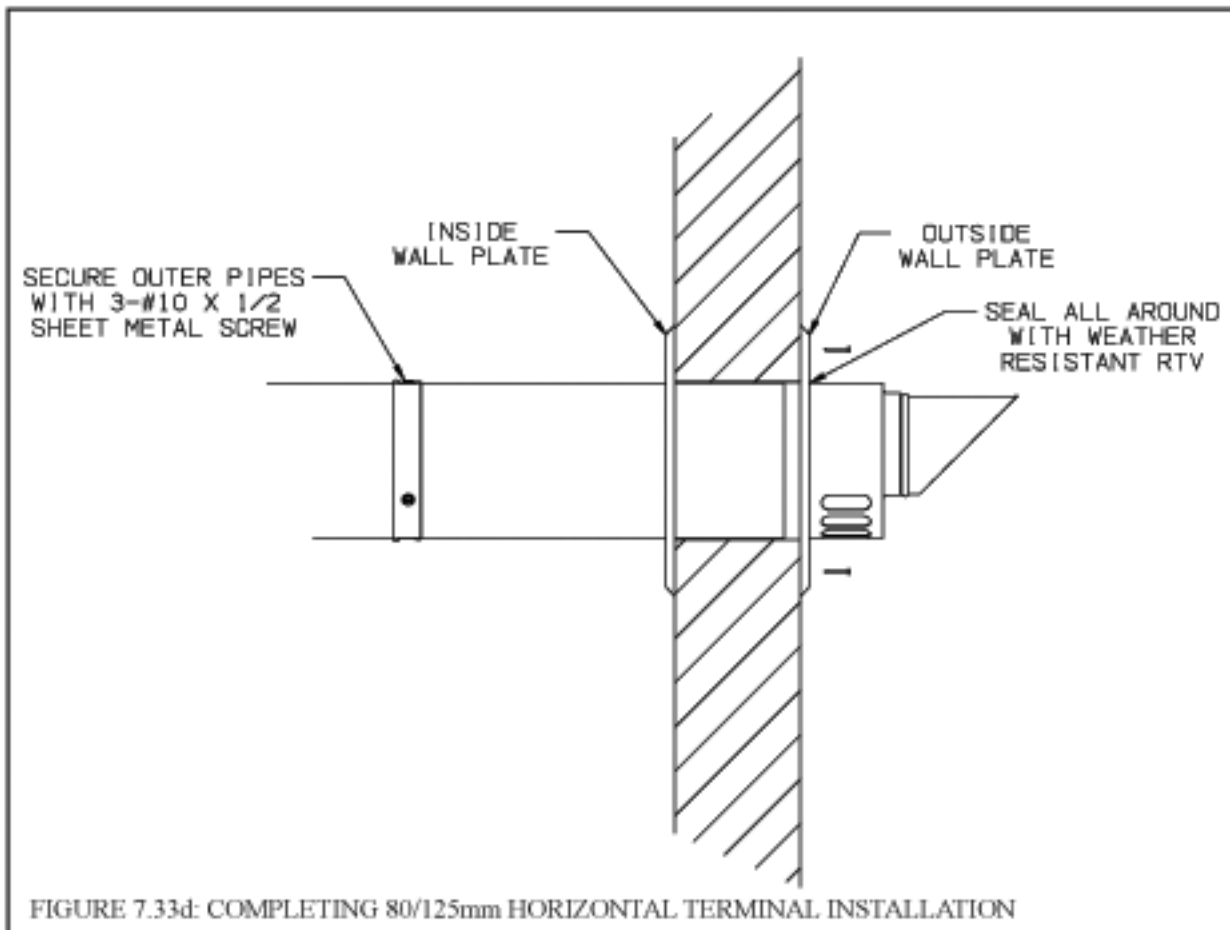
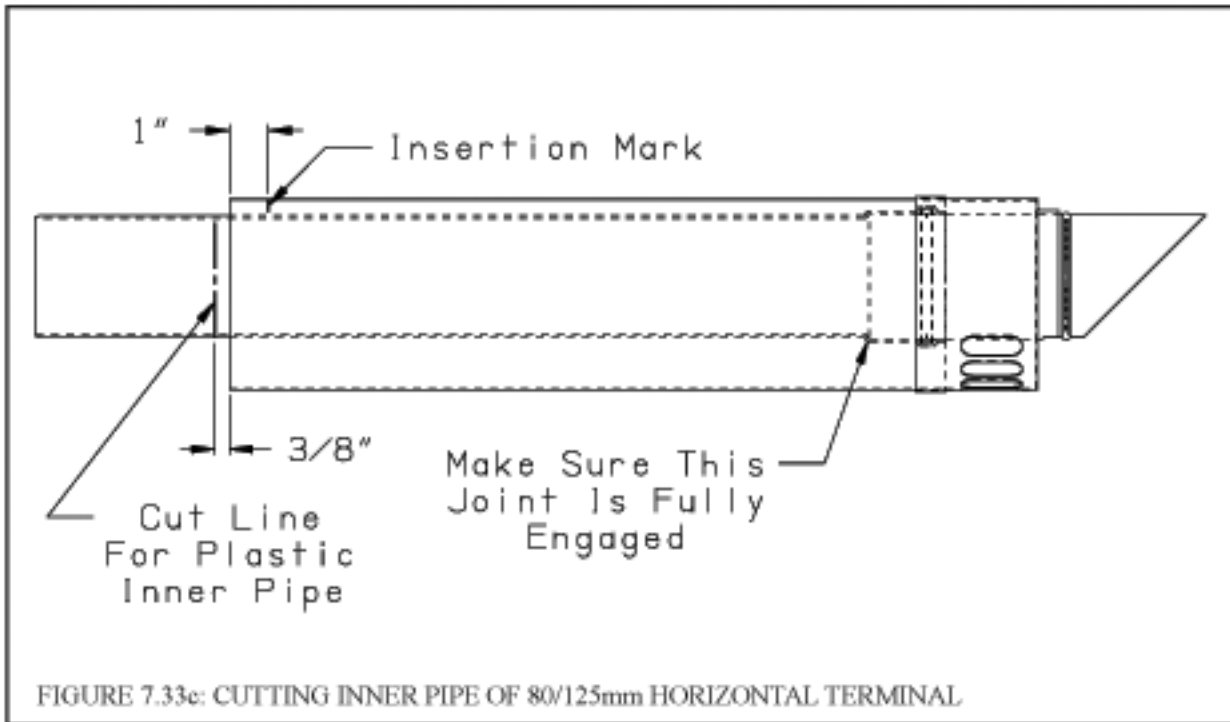

plate to the inside wall.

5) Snorkel Terminal Installation - The Snorkel Kit (PN 230540) consists of the following (Also see Figure 7.34):

Key #	Part #	Description
1	230541	Support Elbow
2	230542	Lower Wall Bracket
3	230543	Air Intake Section
4	230544	Wall Bracket
5	230545	Terminal Elbow
6	230546	Exhaust Terminal
7	230527	Standard Elbow
8	230547	Wall Penetration Section
*	230548	Outer Joint Gasket (2 provided)

IMPORTANT

The Terminal Elbow and Wall Penetration Section included in the snorkel kit have gaskets in the female end of the outer pipe. These gaskets prevent infiltration of rain water into the air intake section. Do not interchange with similar components shown in Table 7.4b.

- Cut a 6" diameter hole through the exterior wall at the planned exit point of the vent. A minimum of 4" is needed between the center line of this hole and grade to install the lower wall bracket.
- Before mounting the lower wall bracket, loosen the M10 x 35 screw on this bracket. Adjust this bolt forward or backward so that its center is 6-7/16" from the wall (Figure 7.34) and tighten.
- Center the Lower Wall Bracket on the hole in the wall and mark the location of the four mounting screws on the wall. 5/16" mounting screws (not supplied) are recommended for mounting this bracket. Drill mounting holes

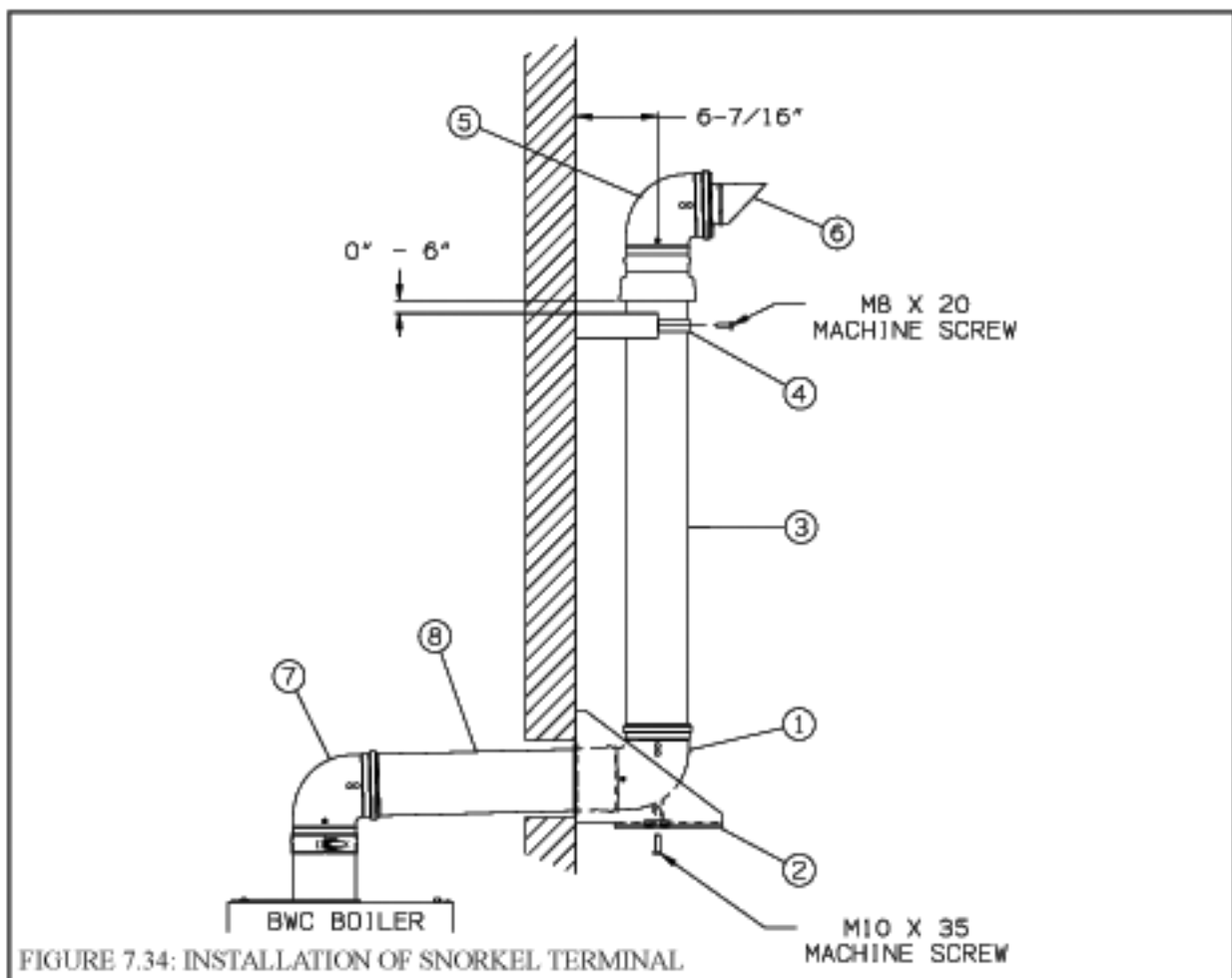

- and mount the bracket.
- d) Complete the vent system inside the structure. The support elbow sits on the M10 x 35 screw as shown in Figure 7.34. Cut the Wall Penetration Section to the length required to connect the interior vent system to the Support Elbow following the instructions on Page 26.
 - e) Remove the Support Elbow from the Lower Support Bracket and attach it to the Wall Penetration Section. Slip this assembly through the Lower Support Bracket. Connect to the interior vent system.
 - f) Slide an Outer Joint Gasket over the male end of the Air Intake Section with the tapered edge of the gasket pointing up. Attach the Air Intake Section to the Support Elbow. If necessary, the Air Intake Section can be shortened by cutting the male end as described on page 26. After attaching the Air Intake Section to the Support Elbow, slide the Outer Joint Gasket down over the joint between the two fittings to prevent rain infiltration.
 - g) Attach the Wall bracket to the wall 0"-6" from the bottom edge of the intake bell (Figure 7.34). Use 1/4" screws (not provided) to mount this bracket.
 - h) Slide the remaining Outer Joint Gasket over the male end of the Terminal Elbow. Attach the Terminal Elbow to the Air Intake Section, pointing it away from the wall. Secure the Terminal Elbow to the Air Intake section with a single #10 x 1/2" sheet metal screw (Figure 7.34). Drill a 1/8" hole through both outer pipes to start this screw. **Use a drill stop or other means to ensure that the drill bit does not penetrate more than 3/8" into the outer pipe. Do not use a sheet metal screw longer than 1/2".** Slide the Outer Joint Gasket down over the joint between the Terminal Elbow and the Air Intake Section to prevent rain infiltration.
 - i) Attach the Exhaust Terminal to the Terminal Elbow (Figure 7.34).
- 6) Vertical Terminal Installation - In addition to the vertical terminal, either a Flat Roof Flashing (PN 230533) or Sloped Roof Flashing (PN 230535) is required for this installation.
- a) Determine the center line of the terminal location on the roof. If the roof is flat, cut a 5-1/2" diameter hole for the terminal. If the roof is sloped, cut a hole large enough for the terminal to pass through the roof while remaining plumb. **Caution: If the boiler is installed directly under the hole, cover it while cutting the hole to prevent saw dust and other debris from falling into the boiler.**
 - b) Install the roof flashing using standard practice for the roofing system on the structure.
 - c) If not already done, assemble the venting system inside the building. The last section of pipe needs to be on the same center line as the terminal and within 19-1/4" of the top edge of the roof flashing (Figure 7.35a).
 - d) Measure distance "H" from the top edge of the storm collar to the end of the last fitting as shown in Figure 7.35a.
 - e) Add 1" to distance "H". Carefully mark this length on the pipe as shown in Figure 7.35b.
 - f) Cut the **outer pipe only** at the point marked in Step (e) using aviation shears, a hacksaw, or an abrasive wheel cutter. Be careful to cut the pipe square. De-burr the cut end with a file or emery cloth.
 - g) Place a mark on the aluminum inner pipe 3/8" beyond the end of the outer pipe (Figure 7.35b). Use a fine tooth hacksaw to cut the aluminum pipe and be careful to cut the pipe square. De-burr the cut edge of the aluminum pipe with a file or emery cloth.
 - h) Make a mark on the terminal section 1" from the cut end of the outer pipe as shown in Figure 7.35b.
 - i) Slip the terminal section through the roof from the outside. Push into the last section of vent pipe until the mark made in Step (h) is not longer visible. Secure the terminal to the last piece of pipe with three #10 x 1/2" sheet metal screws. Drill a 1/8" hole through both outer pipes to start these screws. **Use a drill stop or other means to ensure that the drill bit does not penetrate more than 3/8" into the outer pipe. Do not use a sheet metal screw longer than 1/2".**
 - j) Secure the terminal section to the inside of the roof structure using the mounting bracket provided with the terminal

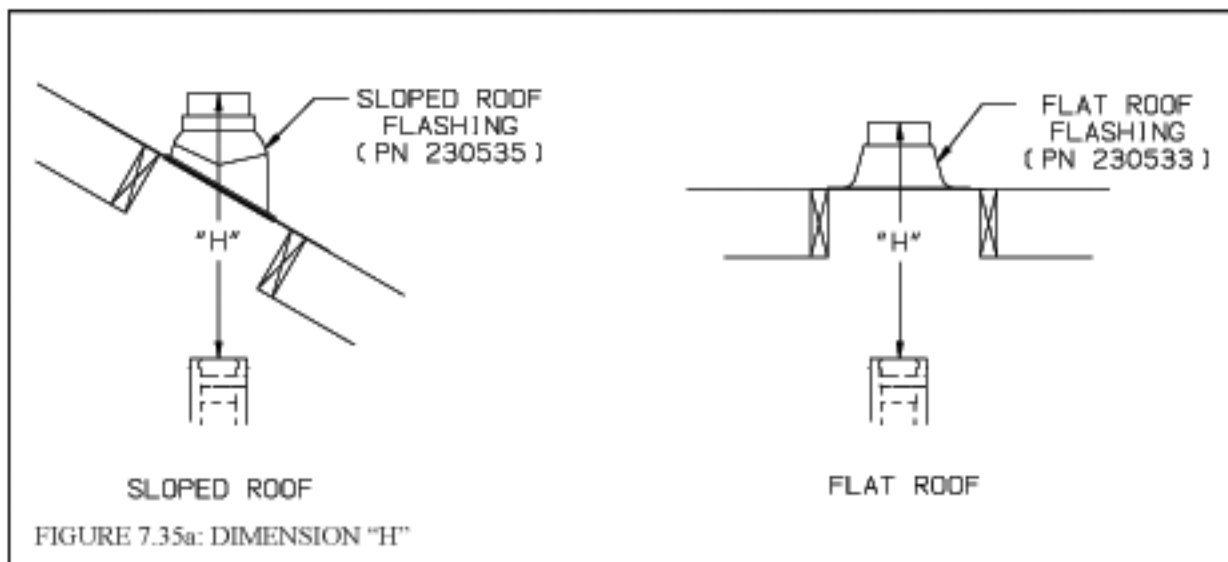

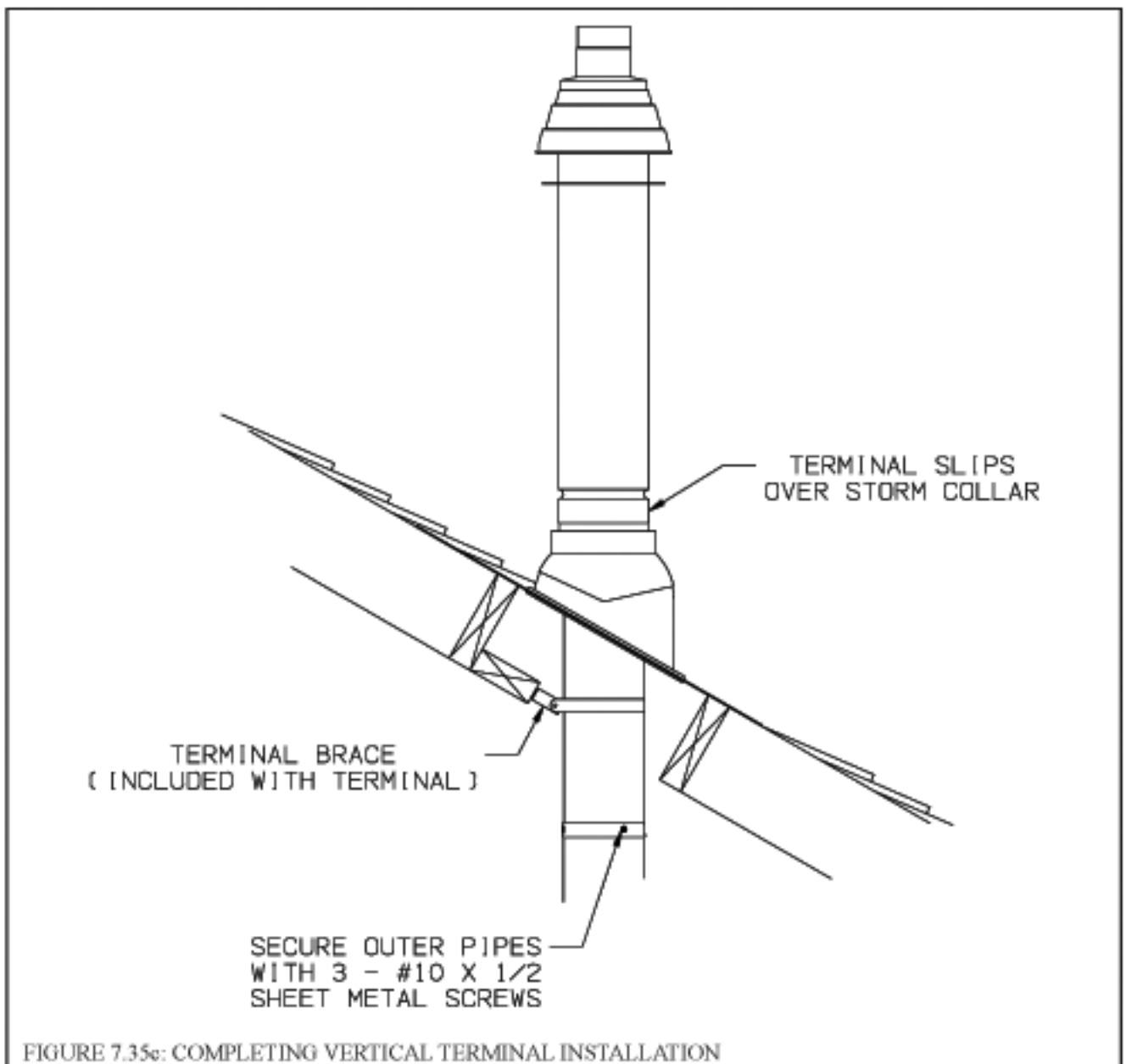
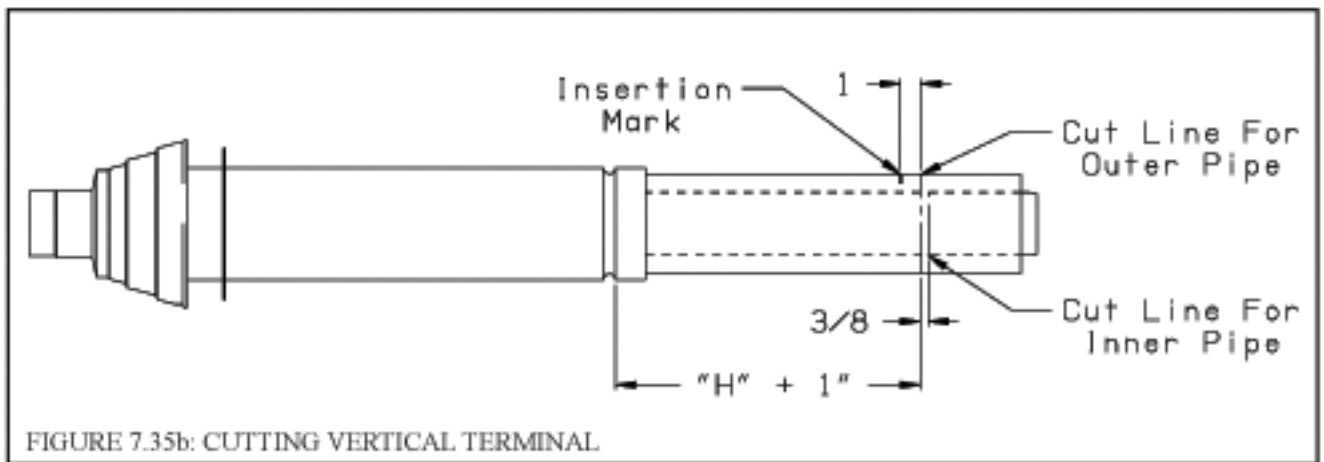

(Figure 7.35c).

7) **Chimney Chase Installation** - A vertical 80/125mm vent system can be installed in an unused masonry chimney. This installation is similar to other vertical installations with the following exceptions (Also see Figure 7.36):

- a) The chimney chase elbow kit (PN230530) is used at the base of the chimney. This kit consists of a support elbow and a mounting bracket. Slip the elbow over the M10 x 35 screw in the support bracket. Determine the desired vertical location of the support elbow in the chimney and mark the location of the pin on the back of the support bracket on the back wall of the chimney. Drill a 7/16" dia x 2-1/2" deep hole at this location to support the back of the bracket. The front of the elbow mounting bracket is supported by the bottom of the opening into the

WARNING

- Do not attempt to construct a vertical vent system inside a chimney that is used to vent a fireplace or other appliances.
- Do not attempt to construct a vertical vent system inside a chimney flue adjacent to another flue used by a fireplace or other appliances.

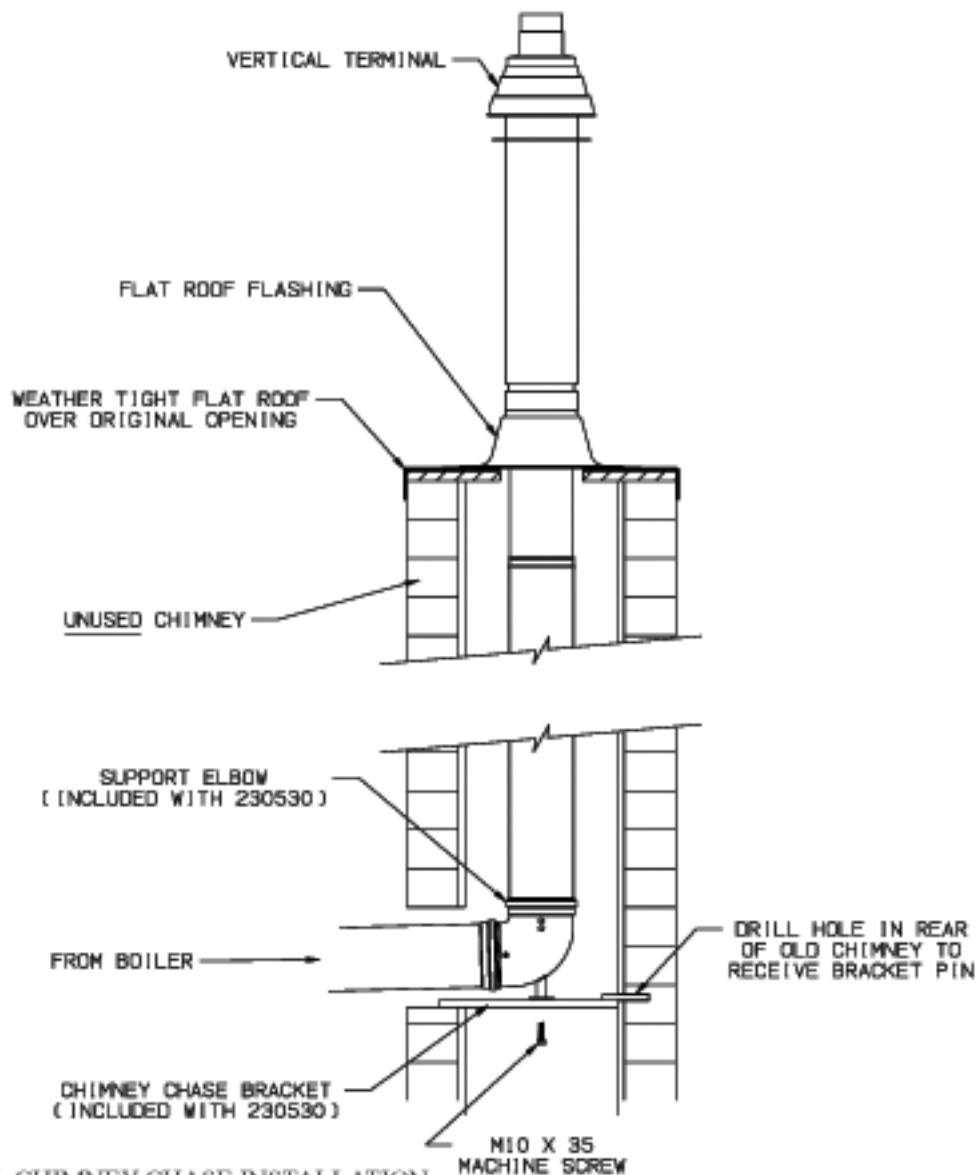

FIGURE 7.36: CHIMNEY CHASE INSTALLATION

E. Assembly of Stainless Steel Venting

CAUTION

Vent systems made by Heat Fab, Protech, Z-Flex, and Metal-Fab rely on gaskets for proper sealing. When these vent systems are used, take the following precautions:

- Make sure that gasket is in position and undamaged in the female end of the pipe.
- Make sure that both the male and female pipes are free of damage prior to assembly.
- Only cut vent pipe as permitted by the vent manufacturer in accordance with their instructions. When pipe is cut, cut end must be square and carefully de burred prior to assembly.

1) General Assembly Notes:

- a) Where the use of "silicone" is called for in the following instructions, use GE RTV 106 for the vent collar. Air inlet piping sections are sealed with any general-purpose silicone sealant such as GE RTV102. PVC air inlet piping sections are connected with PVC cement.
- b) Longitudinal welded seams should not be placed at the bottom of horizontal sections of exhaust pipe.
- c) Do not drill holes in vent pipe.
- d) Do not attempt to mix vent components of different vent system manufacturers.

2) Mounting Stainless steel vent collar -The use of stainless steel venting requires the stainless steel vent collar (Crown PN 230510) which replaces the 80/125mm concentric collar supplied with the boiler. To install the stainless steel vent collar:

- a) Remove the six #10 sheet metal screws which attach the 80/125mm collar to the boiler.
- b) Remove the collar from the boiler (this may be easier if a twisting motion is applied to the collar while removing it).
- c) Lubricate the brown gasket in the female end of the plastic vent stub (inside the boiler) with a few drops of water.
- d) Push the stainless steel vent collar onto the boiler with a slight twisting motion. Make sure that the stainless steel vent adaptor is inserted at least 1" into the boiler stub.
- e) Secure the collar flange to the top of the boiler with the sheet metal screws removed in Step (a)

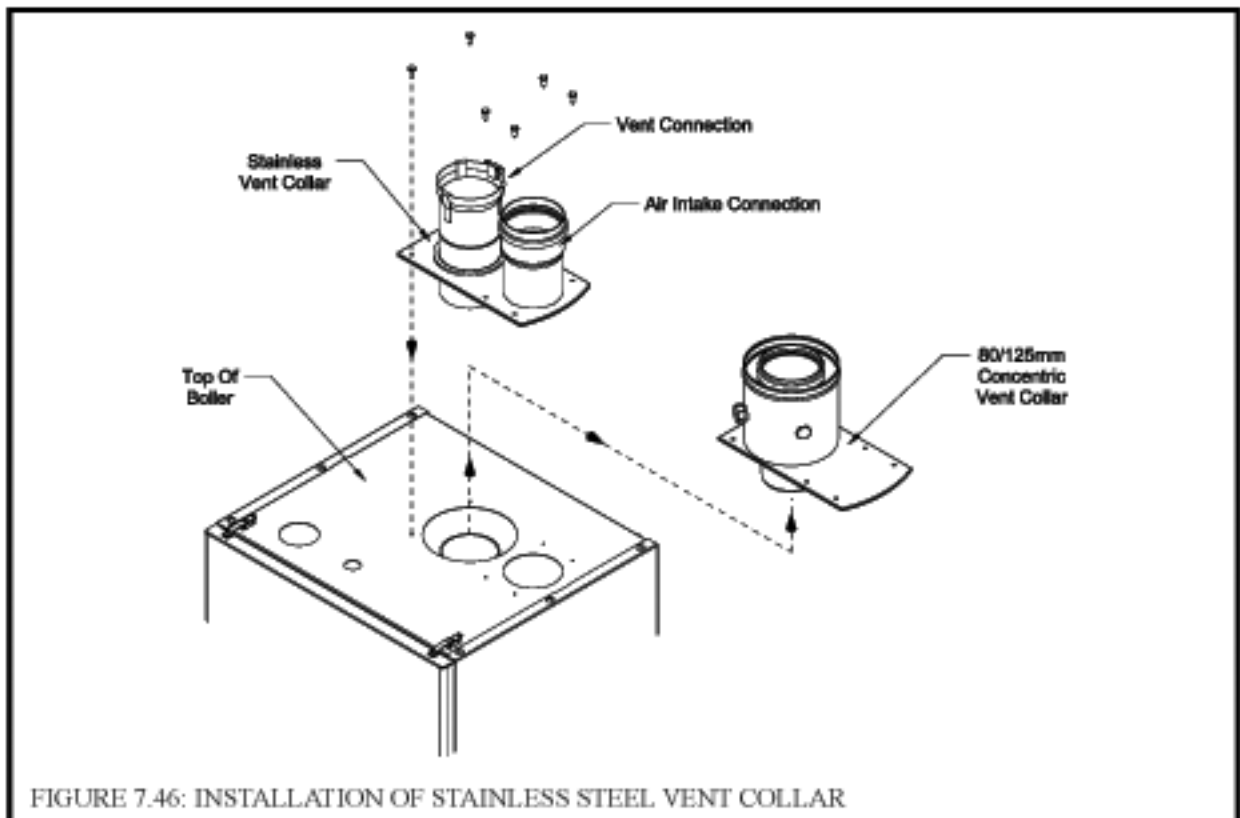

3) Assembly of Metal-Fab Corr/Guard Vent System:

a) Corr/Guard General Notes:

- Do not cut Corr/Guard vent components.
 - Refer to Corr/Guard installation instructions for proper methods of support.
 - Orient Corr/Guard components so that the male ends of all fittings point in the direction of the boiler.
- b) Start assembly of the vent system at the boiler. Remove the hose clamp shipped on the BWC vent collar. Bend the three hose clamp tabs on this collar outward slightly.
- c) Clean the exterior of the male end of the first piece of pipe and the inside of the vent collar on the boiler. Remove dirt, grease, and moisture from the surfaces to be sealed. Dry surfaces or allow to dry thoroughly.
- d) On the male end of the pipe, apply a 1/4" wide bead of silicone approximately 1/2" from the end of the pipe (Fig 7.47).
- e) Insert the male end of the pipe into the boiler vent collar until it bottoms out.
- f) Apply an additional bead of silicone over the outside of the joint and smooth out.
- g) Replace and tighten the clamp on the vent collar.
- h) Assemble remaining Corr/Guard components in accordance with the Corr/Guard installation instructions.
- i) Allow the silicone to cure per the silicone manufacturer's instructions before operating the boiler.

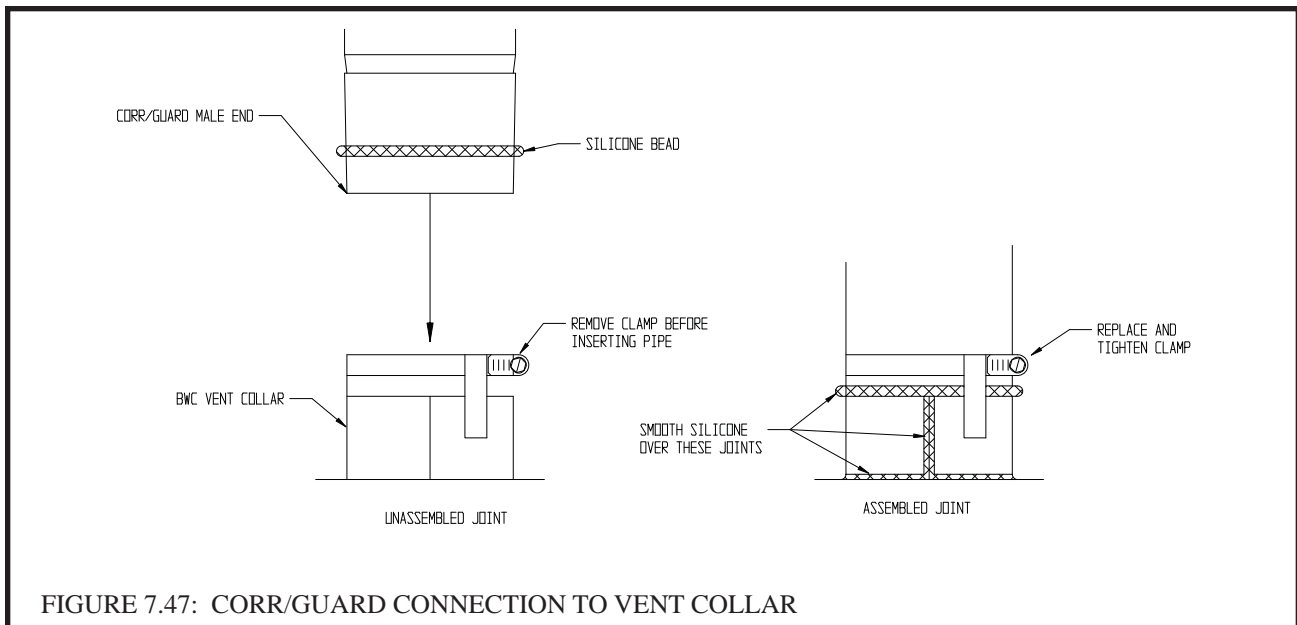
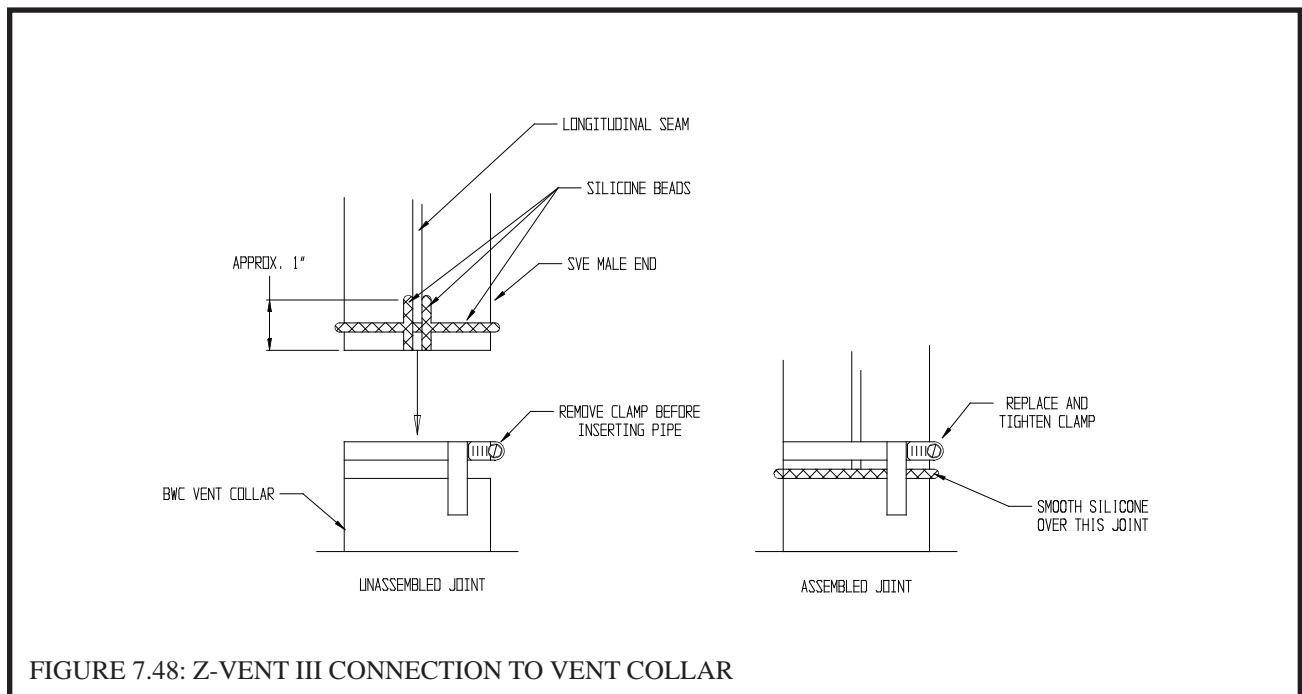

FIGURE 7.47: CORR/GUARD CONNECTION TO VENT COLLAR

4) Assembly of Z-Flex Z-Vent III:

a) General Notes:

- Non-expanded ends of SVE Series III piping sections may be cut using aviation snips or a 24 thread per inch hacksaw. File or sand the cut end smooth before assembling. Expanded ends may be cut to adapt the SVE series III to the vent collar. See the following instructions.
 - Support horizontal piping sections at intervals of 48" or less.
 - Vertical venting systems must be supported by at least one Z-Flex fire stop. An additional vertical support is required after any offset and as required by the Z-Vent III installation instructions.
- b) Start assembly of the vent system at the boiler. Remove the hose clamp shipped on the BWC vent collar. Bend the three hose clamp tabs on this collar outward slightly.
 - c) Clean the exterior of the male end of the first piece of pipe and the inside of the vent collar on the boiler. Remove dirt, grease, and moisture from the surfaces to be sealed. Dry surfaces or allow to dry thoroughly.
 - d) On the male end of the pipe, apply a ¼" wide bead of high temperature silicone approximately ½ inch from the male end of the pipe. Apply ¼" beads of silicone along both sides of the longitudinal seam (Fig. 7.48).
 - e) Insert the male end of the pipe into the boiler vent collar until it bottoms out.
 - f) Apply an additional bead of silicone over the outside of the joint and smooth out.
 - g) Replace and tighten the clamp on the vent collar.
 - h) The female end of each Z-Vent III component has a silicone sealing gasket. Examine all vent components to insure that the gasket integrity has remained during shipping. Gaskets must be in the proper position or flue gas could leak resulting in carbon monoxide poisoning.
 - i) Align the second piece of pipe with the first and push them together as far as they will go, but not less than 1-3/4".
 - j) Tighten gear clamp to a minimum torque of 40 in-lbs and a maximum of 50 in-lbs.
 - k) Repeat Steps (h) – (j) for the remaining Z-Vent III components.
 - l) In horizontal vent systems, a locking band or gear clamp must be used at either side of the wall penetration to prevent shifting of the vent system in and out of the wall. This applies to both combustible and non-combustible walls.
 - n) Allow the silicone to cure per the silicone manufacturer's instructions before operating the boiler.



5) Assembly of Heat Fab Saf-T Vent EZ Seal:

a) Saf-T Vent General Notes:

- These instructions cover the installation of Saf-T Vent EZ Seal. Saf-T Vent EZ Seal piping has integral gaskets installed in the female ends of the pipe which seal the joints.
- In general, Saf-T Vent pipe sections may not be cut. Exceptions to this are the Saf-T Vent slip connector and connections to the boiler vent collar. In these cases, use a sharp pair of aviation snips, an abrasive cut-off, or a plasma cutter. See the Saf-T Vent instructions for information on cutting the slip connector.
- Orient Saf-T Vent components so that the arrows on the piping labels are in the direction of flue gas flow.
- Support horizontal piping sections at intervals of 6 feet or less.
- Vertical venting systems must be supported by at least one Heat Fab support. An additional vertical support is required after any offset.

b) Connection to Boiler – Start assembly of the vent system at the boiler. Remove the hose clamp shipped on the BWC vent collar. Bend the three hose clamp tabs on this collar outward slightly. Cut the “male spigot” off of the first piece of pipe (Fig 7.49). If necessary, crimp the cut end of the pipe so that it can be inserted at least 1” into the collar. Clean the exterior of the male end of the first piece of pipe and the inside of the vent collar on the boiler with an alcohol pad. On the male end of the pipe, apply a ¼” wide bead of high temperature silicone approximately ½ inch from the male end of the pipe. Also apply a ¼” bead of silicone along the first 2 ½” of the longitudinal weld. Insert the male end of the pipe into the boiler vent collar until it bottoms out. Apply an additional bead of silicone over the outside of the joint and smooth out (Fig 7.49). Replace and tighten the clamp on the vent collar.

c) Assembly of Saf-T Vent EZ Seal Vent Components - Clean the male end of the next piece of pipe with an alcohol pad and make sure that it is free of burrs. Check the female end of the first piece of pipe to make sure that the gasket is in place and is undamaged. Using a slight twisting motion, insert the male end of the second fitting into the female end of the first fitting, taking care not to dislodge or cut the factory gasket. In extremely arid conditions, it may be easier to assemble these fittings if the gasket is moistened with water prior to assembly. Bend the locking tabs over the locking ring on the adjacent piece of pipe. Repeat these steps for the remaining Saf-T-Vent components.

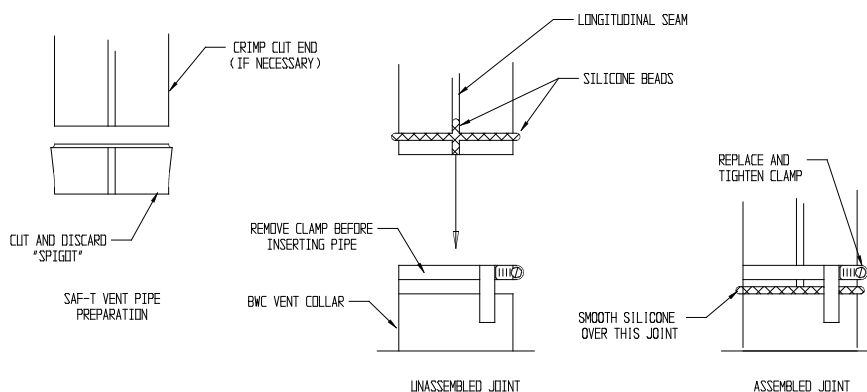

FIGURE 7.49: SAF-T VENT EZ SEAL CONNECTION TO VENT COLLAR

6) Assembly of Protech FasNSeal

a) FasNSeal General Notes:

- Do not cut 4" FasNSeal pipe. Consult FasNSeal instructions for method of cutting other 3" pipe.
- Orient FasNSeal vent components so that the arrows on the piping labels are in the direction of flue gas flow.
- Support horizontal piping sections at intervals of 6 feet or less.
- Vertical venting systems must be supported by at least one FasNSeal support. An additional vertical support is required after any offset.

- b) Remove the hose clamp shipped on the BWC vent collar. Bend the three hose clamp tabs on this collar outward slightly. Clean the exterior of the male end of the first piece of pipe and the inside of the vent collar on the boiler. Remove dirt, grease, and moisture from the surfaces to be sealed. On the male end of the pipe, apply a 1/4" wide bead of high temperature silicone approximately 1/4 inch from the male end of the pipe. Insert the male end of the pipe into the boiler vent collar until it bottoms out. Apply an additional bead of silicone over the outside of the joint and the seams on the vent collar and smooth out (Fig 7.50). Replace and tighten the clamp on the vent collar.
- c) All other joints in the FasNSeal venting system rely on a gasket in the female end of the pipe for a proper seal.
- d) Align the longitudinal seam of both pipes. Insert the male end of the second pipe into the female end of the first pipe until the bead on the male end contacts the flare on the female end.
- e) Tighten the locking band with a nut driver.
- f) Repeat (d) and (e) for the remaining FasNSeal components.
- g) Allow the silicone to cure per the silicone manufacturer's instructions before operating the boiler.

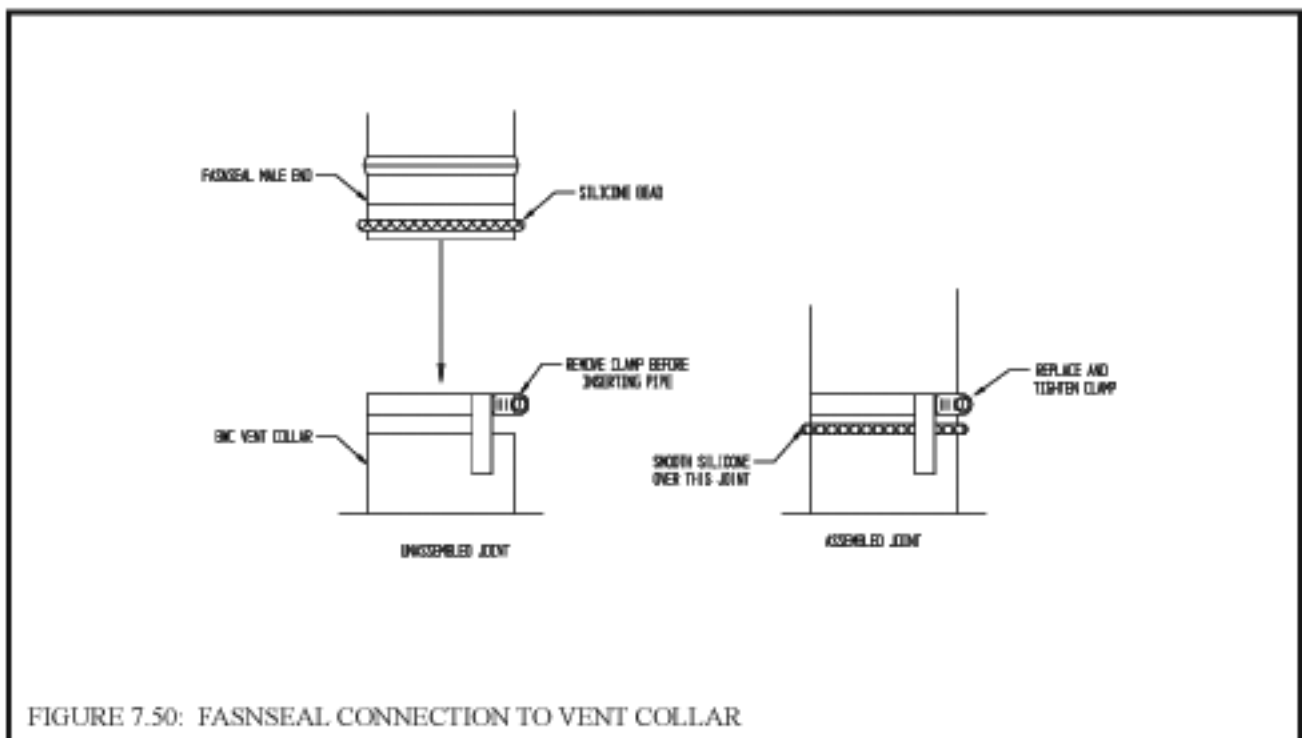

FIGURE 7.50: FASNSEAL CONNECTION TO VENT COLLAR

7) Installation of Horizontal Exhaust Terminal:

- a) When stainless steel venting is used, use Crown stainless exhaust terminal #230511. The outer edge of this terminal must be between 6 and 12 inches from the surface of the wall. **The joint between the terminal and the last piece of pipe must be outside of the building.**
- b) Male end of terminal will fit into the female end of any of the approved stainless vent systems.
- c) Apply a heavy bead of silicone to the male end of the terminal before inserting it into the last piece of pipe. Orient the terminal so that the seam in the terminal is at 12:00.
- d) Smooth the silicone over the seam between the terminal and the last piece of pipe, applying additional silicone if necessary to ensure a tight seal.
- e) Allow the silicone to cure per the silicone manufacturer's instructions before operating the boiler.

8) Installation of Vertical Exhaust Terminal - Use the terminal supplied by the vent system manufacturer shown in Table 7.5. Attach to the vent system, following the assembly instructions in this manual for the stainless vent system being used.

9) Assembly of the Air Intake System and Air Intake Terminals:

- a) Assemble the air intake system using either galvanized or PVC pipe.
- b) If PVC piping is used, use PVC cement to assemble the PVC intake system components.
- c) If galvanized piping is used, use at least two sheet metal screws per joint. Seal the outside of all joints.
- d) 3" galvanized smoke pipe will fit inside the inlet collar on the boiler. Depending upon the exact OD of the pipe used, it may be necessary to crimp this pipe. Secure with a single #10 sheet metal screw through the hole in the inlet collar and seal the outside of the joint with silicone. If PVC is used for the intake system, use a short piece of 3" galvanized pipe to connect the PVC to the boiler. Silicone the outside of the joint between the PVC and galvanized pipe.
- e) Horizontal intake terminal is a 90 degree elbow pointing down. Elbow should protrude the same distance from the wall as the exhaust terminal.
- f) Vertical air intake terminal consists of a 180 degree bend (composed of two 90 degree elbows) as shown in Figure 7.10.
- g) Install a rodent screen (not supplied) in the inlet terminal. Use a screen having 1/2" (2 x 2) or larger mesh.

F. Condensate Trap and Drain Line

All condensate which forms in the boiler or vent system collects in the sump under the heat exchanger and leaves the boiler through the condensate trap. This trap allows condensate to drain from the sump while retaining flue gases in the boiler. The trap is supplied loose and must be installed as shown in Figure 7.51. A length of drain hose is supplied with the boiler and is connected to the trap as shown in Figure 7.51. Note the following when disposing of the condensate:

- a) If the condensate drain line must be extended, construct the extension from PVC or CPVC pipe. Insert the hose provided with the boiler into the end of the extension as shown in Figure 7.51.
- b) Condensate is slightly acidic. Do not use metallic pipe or fittings in the condensate drain line. Do not route the drain line through areas that could be damaged by leaking condensate.
- c) Some jurisdictions may require that the condensate be neutralized before being disposed of. Dispose of condensate in accordance with local codes.
- d) Do not route, or terminate, the condensate drain line in areas subjected to freezing temperatures.
- e) If the point of condensate disposal is above the trap, it will be necessary to use a condensate pump to move the condensate to the drain. In such cases, select a condensate pump that is approved for use with condensing furnaces. If overflow from this pump would result in property damage, select a pump with an overflow switch and use this switch to shut down the boiler. Alternatively, if heat is a necessity, use the overflow switch to trigger an alarm.
- f) Do not attempt to move the trap from the location shown in Figure 7.51. Do not attempt to substitute another trap for the one provided with the boiler.
- g) The vent shown in Figure 7.51 must be left open for the trap to work properly.

WARNING

FAILURE TO INSTALL THE CONDENSATE TRAP AND CONDENSATE DRAIN IN ACCORDANCE WITH THE ABOVE INSTRUCTIONS COULD CAUSE FLUE GAS TO ENTER THE BUILDING, RESULTING IN PERSONAL INJURY OR DEATH.

CAUTION

BOILER CONDENSATE IS CORROSIVE. ROUTE CONDENSATE DRAIN LINE IN A MANNER SUCH THAT ANY CONDENSATE LEAKAGE WILL NOT CAUSE PROPERTY DAMAGE.

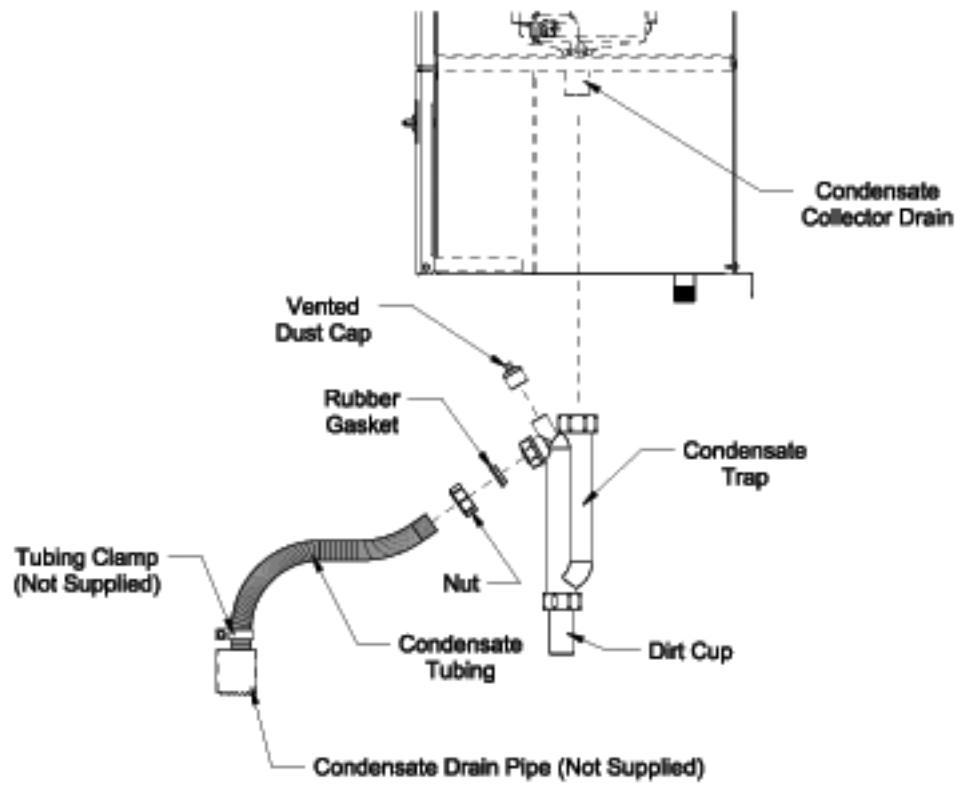

FIGURE 7.51: CONDENSATE PIPING ARRANGEMENT

VIII Gas Piping

Gas piping to the boiler must be sized to deliver adequate gas for the boiler to fire at the nameplate input at an inlet pressure between the minimum and maximum values shown on the rating plate. For more information on gas line sizing, consult the utility or the National Fuel Gas Code.

Figure 8.1 shows typical gas piping connection to the BWC boiler. A sediment trap must be installed upstream of all gas controls. Install the factory provided manual shut-off valve outside the jacket with a ground joint union as shown.

The boiler and its gas connection must be leak tested before placing the boiler in operation. When doing this, the boiler and its individual shut-off must be disconnected from the rest of the system during any pressure testing of that system at pressures in excess of 1/2 psi. When pressure testing the gas system at pressures of 1/2 psi or less, isolate the boiler from the gas supply system by closing its individual manual shut-off valve.

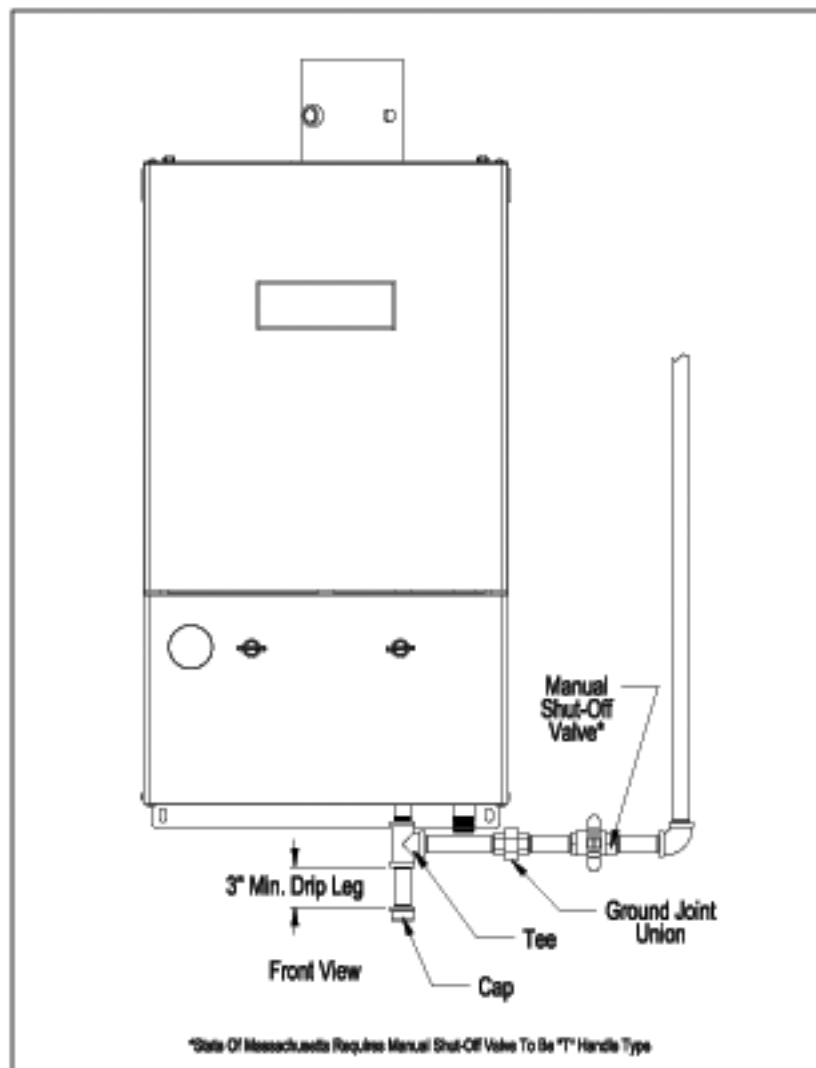

Figure 8.1: Gas Connection To Boiler

IX System Piping

A. General System Piping Precautions

WARNING

INSTALL BOILER SO THAT THE GAS IGNITION SYSTEM COMPONENTS ARE PROTECTED FROM WATER (DRIPPING, SPRAYING, RAIN, ETC) DURING APPLIANCE OPERATION AND SERVICE (CIRCULATOR REPLACEMENT, ETC).

CAUTION

THE HEAT EXCHANGER USED IN THE BWC IS MADE FROM A SPECIAL ALUMINUM ALLOY. FAILURE TO TAKE THE FOLLOWING PRECAUTIONS COULD RESULT IN SEVERE BOILER DAMAGE.

- BEFORE CONNECTING BOILER, MAKE SURE THAT THE SYSTEM IS FREE OF SEDIMENT, FLUX AND ANY RESIDUAL BOILER WATER ADDITIVES. FLUSH THE SYSTEM IF NECESSARY TO ENSURE THAT THESE CONTAMINATES ARE REMOVED.
- DO NOT CONNECT THIS BOILER TO A SYSTEM THAT IS SUBJECT TO REGULAR ADDITIONS OF MAKEUP WATER OR ONE WHICH EMPLOYS RADIANT TUBING WITHOUT AN OXYGEN BARRIER.
- DO NOT ADD ANTIFREEZE OR OTHER BOILER WATER TREATMENT CHEMICALS EXCEPT THOSE LISTED IN PART XI OF THIS MANUAL.
- MAINTAIN THE PRESSURE IN THE BOILER AT A MINIMUM OF 12 PSI.
- DESIGN SYSTEM TO ENSURE THAT THE FLOW FALLS WITHIN THE LIMITS CALLED FOR IN TABLE 9.1.

B. System Design

Proper operation of the BWC boiler requires that the water flow through the boiler remain within the limits shown in Table 9.1 any time the burner is firing. Failure to maintain the flow within these limits could result in erratic operation or premature boiler failure.

There are two basic methods that can be used to pipe the BWC boiler. Method #1 is almost always preferred. The instructions on the following pages describe these methods for piping BWC boilers and explain how to size the circulator and piping. Additional information on hydronic system design may be found in Installation of Residential Hydronic Systems (Pub. #200) published by the Hydronics Institute in Berkeley Heights, NJ.

TABLE 9.1: FLOW REQUIREMENTS THROUGH BOILER

BOILER MODEL	MIN. REQUIRED FLOW (GPM)	MAX. ALLOWABLE FLOW (GPM)
BWC070	4.0	9.0
BWC090	4.0	9.0
BWC120	4.5	12.0
BWC151	6.0	15.0

Method 1: Primary/Secondary Piping

This method can be used in heat-only applications as shown in Figure 9.2 or with an indirect water heater as shown in Figure 9.3. This method relies on primary/secondary pumping to ensure that the required flow is always maintained through the boiler. In this system, the flow rate through the boiler is completely independent of the flow rate through the heating system. Use the following guidelines to ensure that the boiler will have the required flow shown in Table 9.1 regardless of the flow in the heating system.

- 1) Primary Loop Piping - Size the primary circulator and piping to obtain the design flow rate through the heating system as you would on any other heating system. All piping between the expansion tank and secondary connection tees must be at least as large as that shown in Table 9.5, column (a). In order to keep the flow rates in the primary and secondary loops independent of each other, provide at least 8 diameters of straight pipe upstream of the first secondary tee and 4 diameters downstream of the second secondary tee. Keep the distance between the expansion tank and the first secondary tee as short as practical.
- 2) Secondary Loop ("Boiler Loop") Piping - All piping must be the size shown for the boiler in Table 9.5, column (a). To size the circulator:
 - a) Select one of the boiler water flow rates shown in Table 9.5, column (b) for the boiler being installed. When selecting the required boiler flow rate, keep in mind that if the flow rate in the primary loop exceeds the flow rate through the boiler, it will not be possible to obtain a 180F supply temperature in the primary loop. This is because the supply water exiting the boiler will be mixed with cooler system return water before entering the radiation.
 - b) Count all fittings in the planned secondary loop (the secondary loop consists of the shaded piping in Figure 9.4a). In doing so, do not count the secondary connection tees, unions, or the fittings supplied with the boiler (these have already been accounted for).
 - c) Using Table 9.7, find the equivalent lengths of all fittings in the secondary loop. Total these equivalent lengths and add them to the total length of planned straight pipe in the secondary loop. The result is the total equivalent length of the secondary loop.
 - d) Using Table 9.5, find the boiler size being installed and select a boiler secondary circulator that shows a "maximum equivalent length" (column e) in excess of the total equivalent length calculated in Step (c).
- 3) Indirect Water Heater Loop Piping (If Indirect Water Heater is Used) - All piping must be the size shown in Table 9.6, column (a). If the indirect water heater connections are smaller than the pipe size called for in column (a), reduce the pipe size at the indirect water heater connections. To size the circulator:
 - a) Count all fittings in the planned Indirect Water Heater Loop (the indirect water heater loop consists of the shaded piping in Figure 9.4b). In doing so, you will be counting some piping and fittings which are common to the heating system secondary ("boiler loop") piping and which were counted in Step 2a above. Do not count the elbows or fittings supplied with the boiler.
 - b) Using Table 9.7, find the equivalent lengths of all fittings in the indirect water heater loop. Total these equivalent lengths and add them to the total length of planned straight pipe in the indirect water heater loop. The result is the total equivalent length of the indirect water heater loop.
 - c) Using Table 9.6, find the boiler size being installed and select an indirect water heater loop circulator that shows a "maximum equivalent length" (column f) in excess of the total equivalent length calculated in Step b.

Example - Assume that a BWC120 is to be installed in a heating system along with a Crown MS-40 indirect water heater. A total of 15 ft of straight pipe will be installed between the boiler and the primary loop. A total of 20 ft of straight pipe will be installed between the boiler and the indirect water heater. Fittings are arranged as shown in Figure 9.3. A 9.0 GPM flow is required in the boiler loop. The MS-40 requires a flow rate of 8 GPM and has a head loss of 3.0 ft.

Total fittings in Secondary loop ("boiler loop"):

*6 90 Elbows
2 Runs of Tees
1 Swing Check
2 Isolation Valves*

Note: Unions, Secondary Connection Tees, and factory supplied fittings are ignored.

Calculate total equivalent length from Table 9.7:

15ft Straight Pipe + 6 Elbows x 2.75 + 2 Runs of Tees x 1.75 + 1 Swing Check x 7 + 2 valves x 0.6 = 43.2 equivalent feet straight pipe. From Table 9.5, we see that a Taco 0014 will pump 9 GPM through a BWC120 with 61 equivalent feet of pipe, so the Taco 0014 is OK.

Example (contd.)

Total fittings in Indirect Water Heater Loop:

- 5 90 Elbows
- 2 Turns in Tees
- 1 Swing Check
- 2 Isolation Valves

Calculate total equivalent length from Table 9.7:

20 Straight Pipe + 5 Elbows x 2.75 + 2 Turns in Tees x 5.5 + 1 Swing Check x 7 + 2 valves x 0.6 = 52.95 Equivalent Feet Straight Pipe. From Table 9.6, we see that smallest circulator which will pump at 8 GPM through a BWC120 with 52.95 equivalent feet and an indirect water heater pressure drop of 3 ft is a Taco 0014.

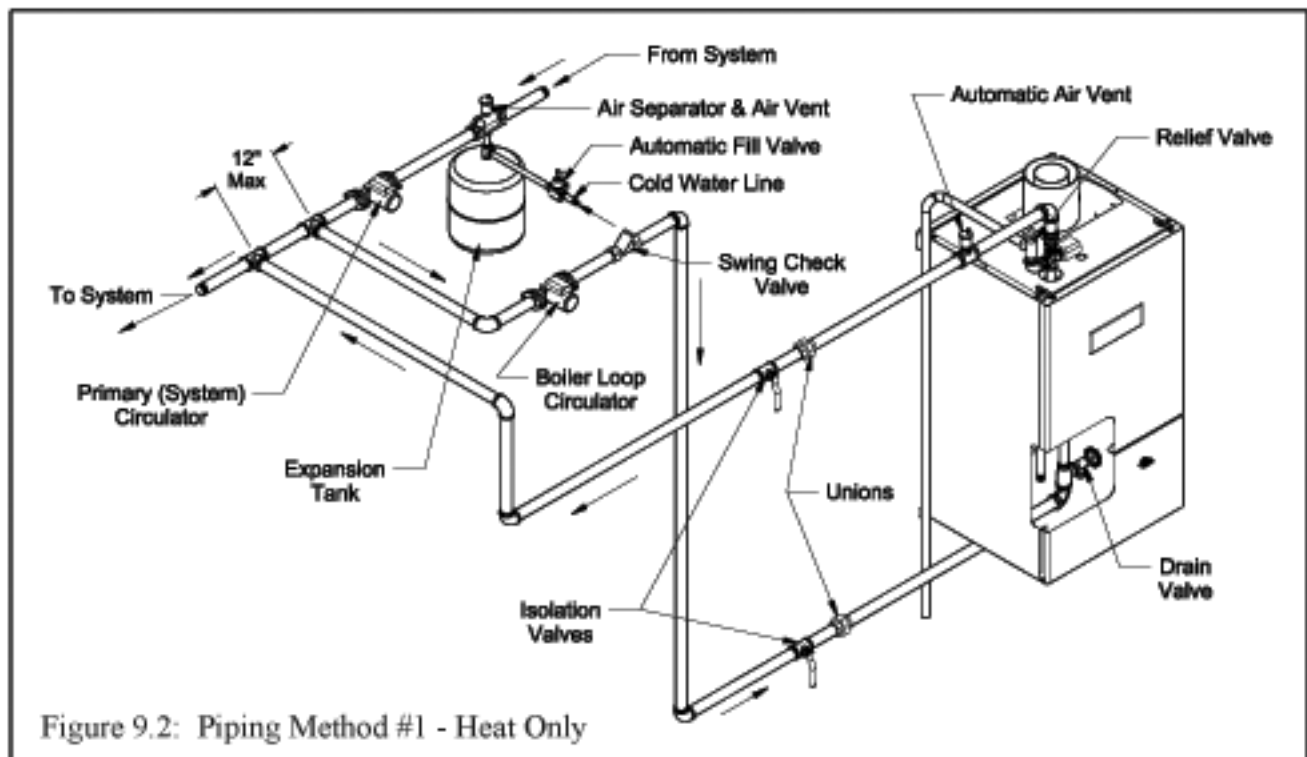

Figure 9.2: Piping Method #1 - Heat Only

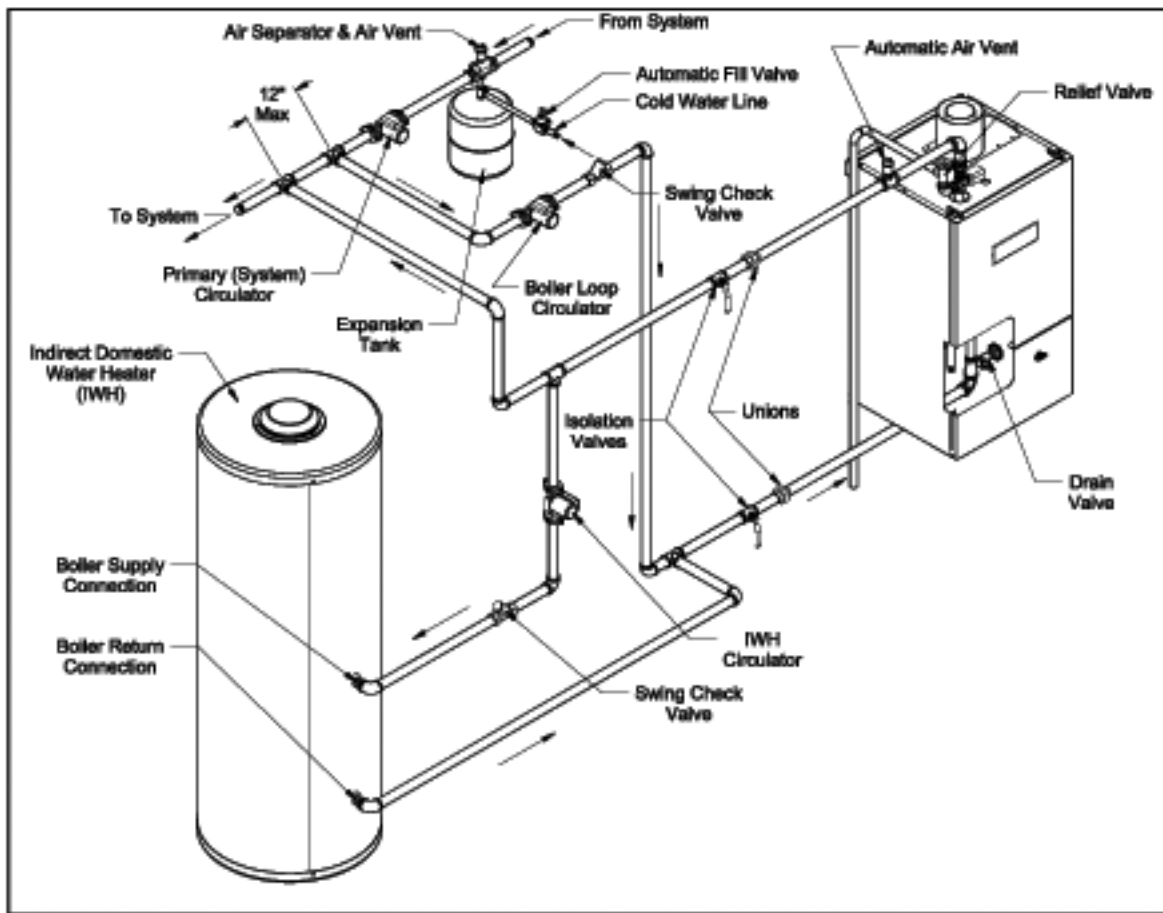

Figure 9.3: Piping Method #1 - Heat + Indirect Water Heater

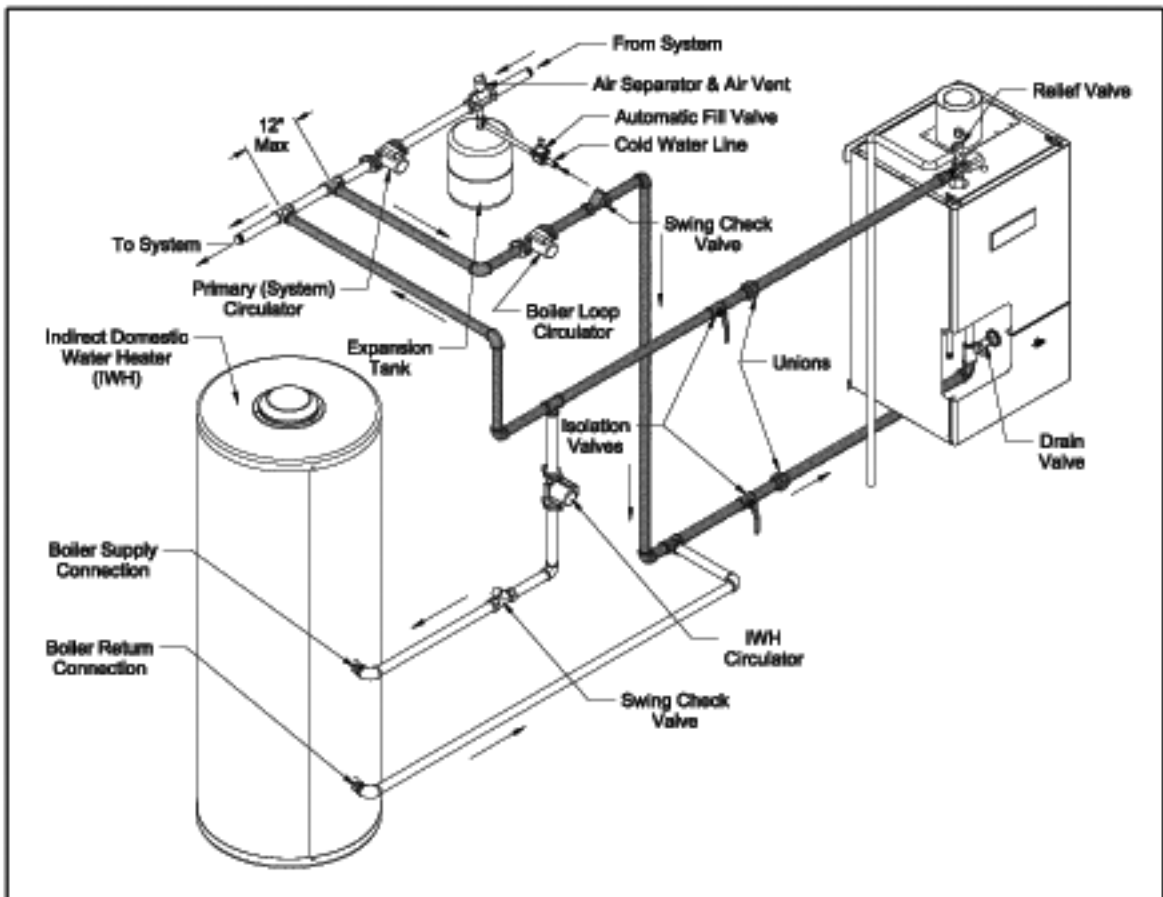

Figure 9.4a: Piping Method #1 - Secondary Loop Piping (Shaded)

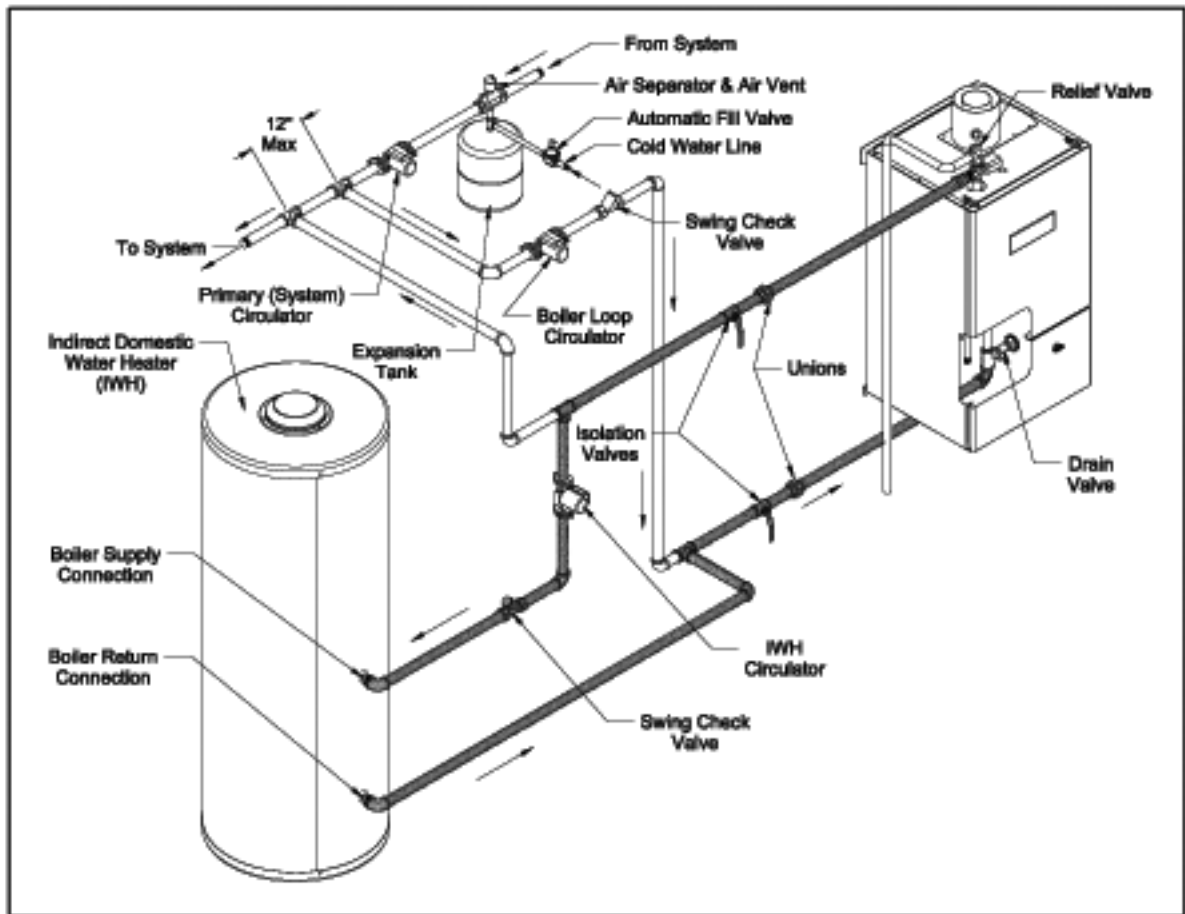

Figure 9.4b: Piping Method #1 - Indirect Water Heater Loop Piping (Shaded)

TABLE 9.5: PIPE AND CIRCULATOR SIZING FOR BOILER LOOP

BOILER MODEL	(a) PIPE SIZE (in NPT)	(b) FLOW (GPM)	(c) TEMP RISE (F)	(d) CIRCULATOR MODEL	(e) BOILER LOOP MAX EQUIVALENT LENGTH (ft)
BWC070	1	6.0	21	Taco 007	67
BWC070	1	6.0	21	Taco 008	171
BWC090	1	8.0	21	Taco 0014	135
BWC120	1	8.0	29	Taco 0014	166
BWC120	1	9.0	25	Taco 0014	95
BWC120	1	12.0	19	Taco 0013 (Note #1)	51
BWC151	1	8.0	34	Taco 008	106
BWC151	1	11.0	25	Taco 0014	68
BWC151	1	14.0	19	Taco 0013 (Note #1)	59

NOTE: 1) Use isolation relay between Taco 0013 and BWC - see Figure 10.3

TABLE 9.6: PIPE AND CIRCULATOR SIZING FOR INDIRECT WATER HEATER LOOP

BOILER MODEL	(a) PIPE SIZE (in NPT)	(b) FLOW (GPM)	(c) MAX. I.W.H. PRESSURE DROP (ft HEAD)	(d) CROWN INDIRECT WATER HEATERS	(e) CIRCULATOR MODEL	(f) I.W.H. LOOP MAX EQUIVALENT LENGTH (ft)
BWC070	1	6.0	1.7	MS-26 (*) MS-40 (*) MSH-40H (*) MT040GBR (*)	Taco 008	122
BWC090	1	8.0	3.0	MS-26 MS-40 (*) MSH-40H MT040GBR (*)	Taco 0014	78
BWC120	1	8.0	3.0	MS-26 MS-40 MSH-40H MT040GBR MT050GBR MT065GBR MT080GBR	Taco 0014	108
BWC120	1	8.0	5.0	MSH-53H	Taco 0014	70
BWC151	1	8.0	3.0	MS-26 MS-40 MSH-40H MT040GBR MT050GBR MT065GBR MT080GBR	Taco 008	49
BWC151	1	8.0	5.0	MS-53 MS-53H MSH-79(*)	Taco 0014	150

TABLE 9.6 NOTES:

1) Indirect water heaters with an asterisk (*) will not achieve their catalog rating due to inadequate boiler water flow and/or inadequate boiler output.

TABLE 9.7: FITTING EQUIVALENT LENGTHS

FITTING	PIPE SIZE	EQUIVALENT LENGTH (ft)
90 ELBOW	1	2.75
TURN IN TEE	1	5.50
RUN OF TEE	1	1.75
SWING CHECK	1	7.00
GATE VALVE	1	0.60

Method 2: Direct Connection to Heating System (Generally NOT Recommended)

The BWC can be connected directly to the heating system as is done with conventional boilers (Figure 9.8). If this is done, the flow rate through the boiler will equal the flow rate through the system. The flow rate through the system must therefore always remain within the limits shown in Table 9.1. For this reason, the pressure drop through the entire system must be known, added to the boiler pressure drop, and a circulator selected which will provide the required flow at the total calculated pressure drop.

This method is generally not recommended because it is often very difficult to accurately calculate the pressure drop through the system. In replacement installations, it may be impossible to get an accurate measurement of the amount of piping and number of fittings in the system. In addition, if the system is zoned, the system flow may drop well below the minimum required when only one zone is calling for heat.

The one advantage to this method is its installation simplicity. It may make sense to use this method when the boiler is to be installed with a new single zone system having a low-pressure drop. Pressure drop curves for the BWC Series boilers are shown in Figure 9.9. Calculation of the system pressure drop, and selection of the circulator, must be performed by someone having familiarity with pressure drop calculations, such as an HVAC engineer.

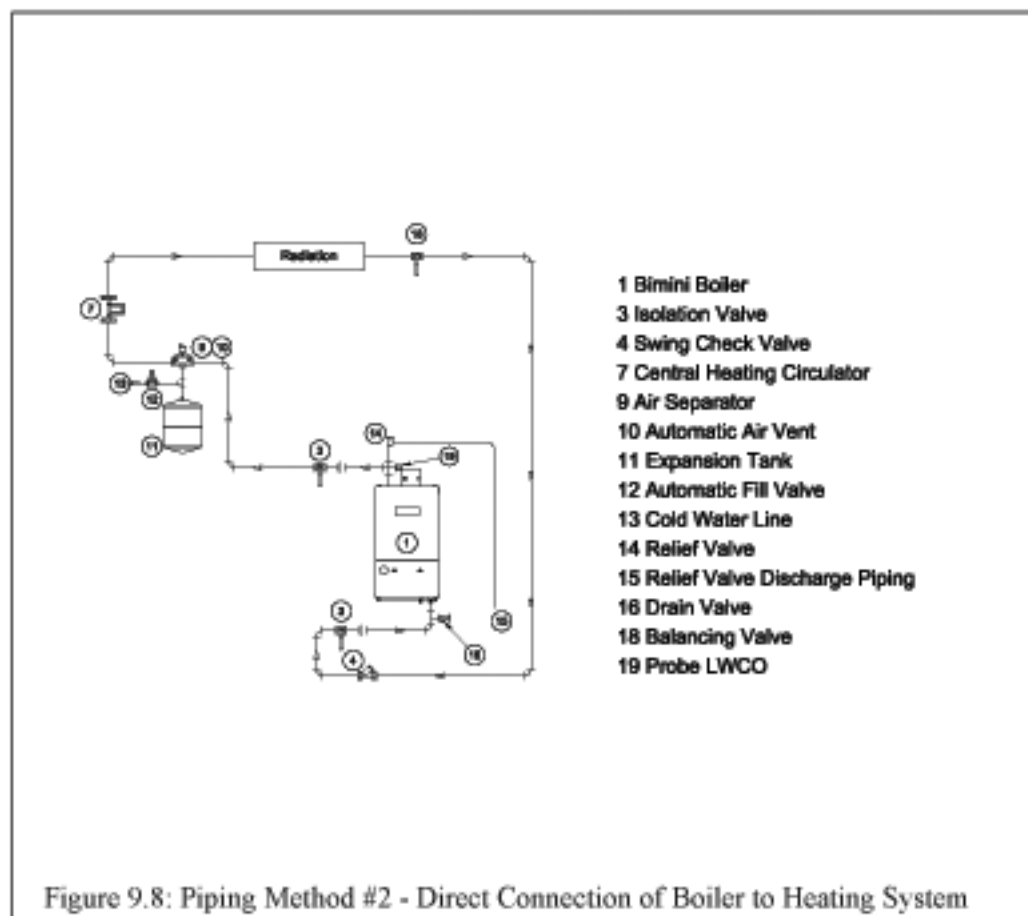

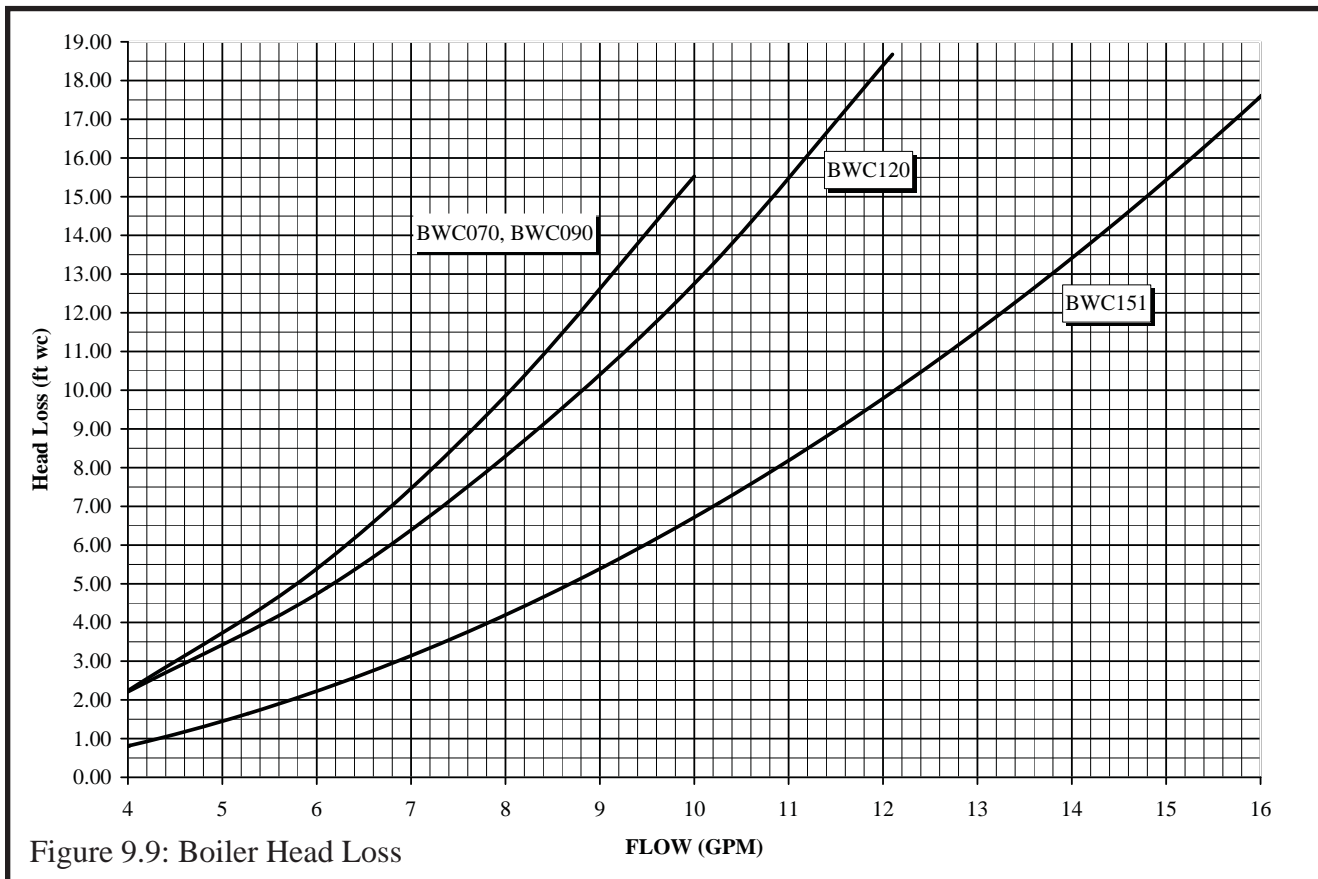

C: Standard Piping Installation Requirements

Observe the following guidelines when making the actual installation of the boiler piping:

- 1) The relief valve is packaged loose with the boiler and must be installed in the location shown in Figure 2.1. The relief valve is set to open at 30 psi. If the valve is replaced, the replacement must have a relief capacity in excess of the DOE heating capacity for the boiler. Pipe the discharge of the relief valve to a location where water or steam will not create a hazard or cause property damage if the valve opens. The end of the discharge pipe must terminate in an unthreaded pipe. If the relief valve discharge is not piped to a drain, it must terminate at least 6 inches above the floor. Do not run relief valve discharge piping through an area that is prone to freezing. The termination of the relief valve discharge piping must be in an area where it is not likely to become plugged by debris.

DANGER

- PIPE RELIEF VALVE DISCHARGE TO A SAFE LOCATION.
- DO NOT INSTALL A VALVE IN THE RELIEF VALVE DISCHARGE LINE.
- DO NOT INSTALL RELIEF VALVE IN A LOCATION OTHER THAN THAT SPECIFIED BY THE FACTORY.
- DO NOT PLUG THE RELIEF VALVE DISCHARGE.

- 2) Circulator (Required) - Usually at least two circulators will be required to properly install a BWC Series boiler. See the previous section for information on sizing the circulators.
- 3) Expansion Tank (Required) - If this boiler is replacing an existing boiler with no other changes in the system, the old expansion tank can generally be reused. If the expansion tank must be replaced, consult the expansion tank manufacturer's literature for proper sizing.
- 4) Fill Valve (Required) - Either a manual or automatic fill valve may be used. The ideal location for the fill is at the expansion tank.
- 5) Automatic Air Vent (Required) - At least one automatic air vent is required. Manual vents will usually be required in other parts of the system to remove air during initial fill.

IMPORTANT

If there are any downturns, or downward pitches, in the boiler supply piping between the boiler and the automatic air vent mounted on the system's air separator, install a second automatic air vent in the supply piping as close as possible to the boiler (Figures 9.2-9.4). This will prevent nuisance low water cut-off lockouts due to trapped air.

- 6) Manual Reset High Limit (Required by some codes) - This control is required by ASME CSD-1 and some other codes. Install the high limit in the boiler supply piping just above the boiler with no intervening valves. Set the manual reset high limit to 200°F. Wire the limit per Figures 10.1 & 10.2 in the Wiring section.
- 7) Flow Control Valve (Required) - The flow control valve prevents flow through the system unless the circulator is operating. Flow control valves are used to prevent gravity circulation or "ghost flows" in circulator zone systems through zones that are not calling for heat.
- 8) Isolation Valves (Recommended) - Isolation valves are useful when the boiler must be drained, as they will eliminate having to drain and refill the entire system.
- 9) Drain Valve (Required) - The drain valve is installed on the return tee located in the lower vestibule compartment as shown in Figure 9.2.
- 10) Low Water Cut-off (Required) - The low water cut-off supplied with this boiler must not be removed.

D. Piping for Special Situations

- 1) Systems containing oxygen - Many hydronic systems contain enough dissolved oxygen to cause severe corrosion damage to an aluminum boiler such as the BWC. Some examples include:
 - Radiant systems that employ tubing without an oxygen barrier.
 - Systems with routine additions of fresh water.
 - Systems which are open to the atmosphere.

If the boiler is to be used in such a system, it must be separated from the oxygenated water being heated with a heat exchanger as shown in Figure 9.10. Consult the heat exchanger manufacturer for proper heat exchanger sizing as well as flow and temperature requirements. All components on the oxygenated side of the heat exchanger, such as the pump and expansion tank, must be designed for use in oxygenated water.
- 2) Piping with a Chiller - If the boiler is used in conjunction with a chiller, pipe the boiler and chiller in parallel as shown in Figure 9.11. Use isolation valves to prevent chilled water from entering the boiler.
- 3) Air Handlers - Where the boiler is connected to air handlers through which refrigerated air passes, use flow control valves in the boiler piping or other automatic means to prevent gravity circulation during the cooling cycle.

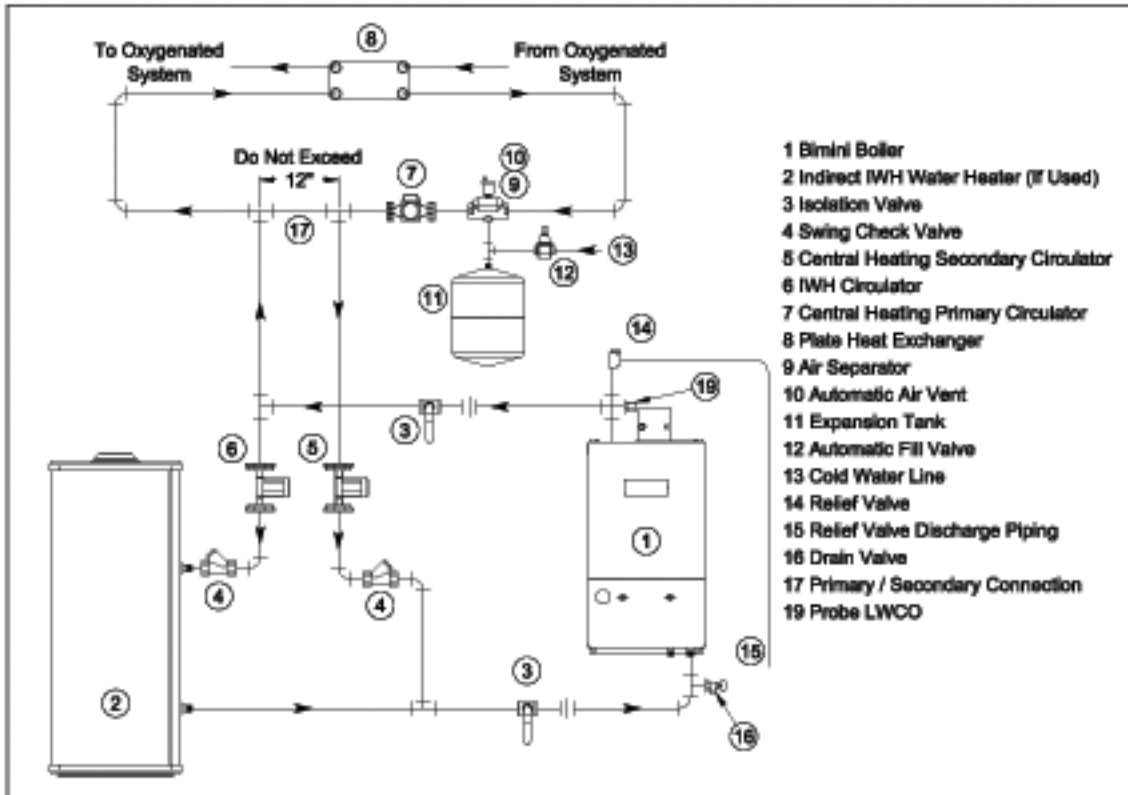

Figure 9.10: Isolation of the Boiler From Oxygenated Water with A Plate Heat Exchanger

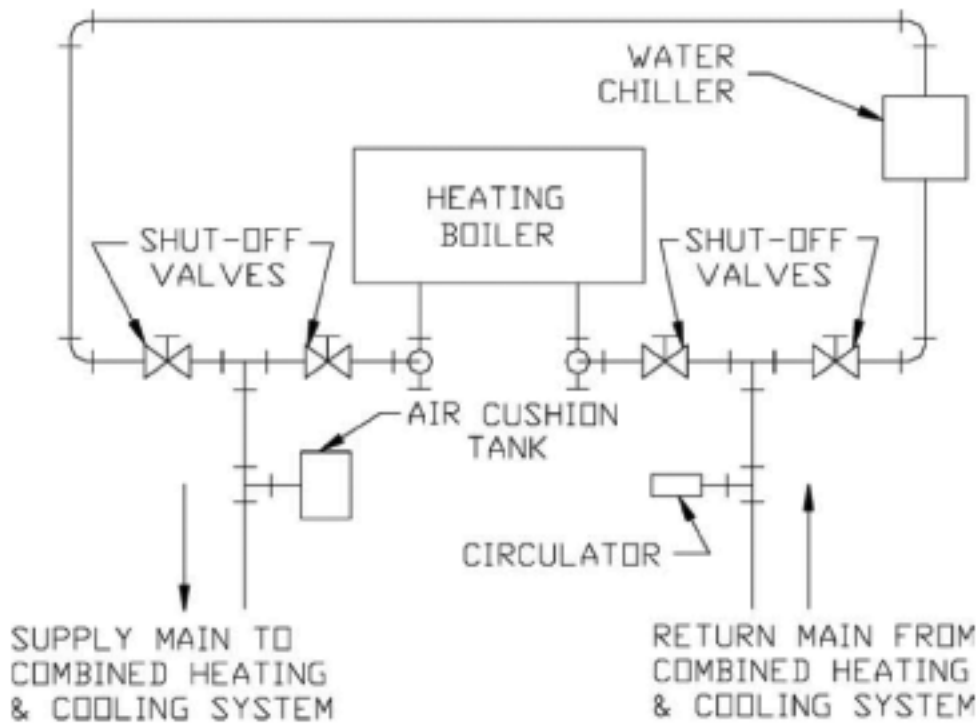

Figure 9.11: Chiller Piping

X Wiring

WARNING

All wiring and grounding must be done in accordance with the authority having jurisdiction or, in the absence of such requirements, with the National Electrical Code (ANSI/NFPA 70).

- 1) Line Voltage (120 VAC) Connections (Fig 10.1) – The line voltage connections are located in the junction box on the right side of the vestibule:
 - Black – Line voltage “hot”
 - White – “Neutral” for boiler and circulators
 - Red – “Heating” circulator “hot”
 - Blue – “Indirect Water Heater “ circulator “hot”
 - Green – Ground connection
- 2) Maximum circulator continuous current draw is 2A. When Piping Method #1 is used, it may be desirable to use the boiler to directly control the primary circulator in addition to the secondary circulator. If this is done, control both heating circulators using a relay with a 120VAC coil, such as a Honeywell R4222, as shown in Figure 10.3. Select a relay with a contact rating in excess of the combined draw of the two circulators.
- 3) Low Voltage Connections (Fig 10.1) – These connections are screw terminals located on the terminal strip next to the junction box on the left:
 - Terminals 1 and 2 – “Heating” thermostat connections
 - Terminals 3 and 4 – “External Limit Control” connections
 - Terminals 5 and 6 – “Outdoor Reset Sensor” connections
 - Terminals 7 and 8 – “Domestic Indirect Water Heater” thermostat connections
 - Terminal 9 – “Flame Signal Reading”
 - Heat anticipator setting for the thermostat connection is 0.1 A when thermostat is connected directly to terminals 1 and 2.

CAUTION

- WHEN MAKING LOW VOLTAGE CONNECTIONS, MAKE SURE THAT NO EXTERNAL POWER SOURCE IS PRESENT IN THE THERMOSTAT OR LIMIT CIRCUITS. IF SUCH A POWER SOURCE IS PRESENT, IT COULD DESTROY THE BOILER’S MICROPROCESSOR CONTROL (MCBA). ONE EXAMPLE OF AN EXTERNAL POWER SOURCE THAT COULD BE INADVERTENTLY CONNECTED TO THE LOW VOLTAGE CONNECTIONS IS A TRANSFORMER IN OLD THERMOSTAT WIRING.

- 4) If the outdoor sensor is connected to terminals 5 and 6, the boiler will adjust the target space heating set point supply water temperature downwards as the outdoor air temperature increases. If used, this sensor should be located on the outside of the structure in an area where it will sense the average air temperature around the house. Avoid placing this sensor in areas where it may be covered with ice or snow. In general, locations where the sensor will pick up direct radiation from the sun should also be avoided. Avoid placing the sensor near potential sources of electrical noise such as transformers, power lines, and fluorescent lighting. Wire the sensor to the boiler using 22 gauge or larger wire. As with the sensor, the sensor wiring should be routed away from sources of electrical noise. Where it is impossible to avoid such noise sources, wire the sensor using a 2 conductor, UL Type CM, AWM Style 2092, 300Volt 60°C shielded cable. Connect one end of the shielding on this cable to ground.

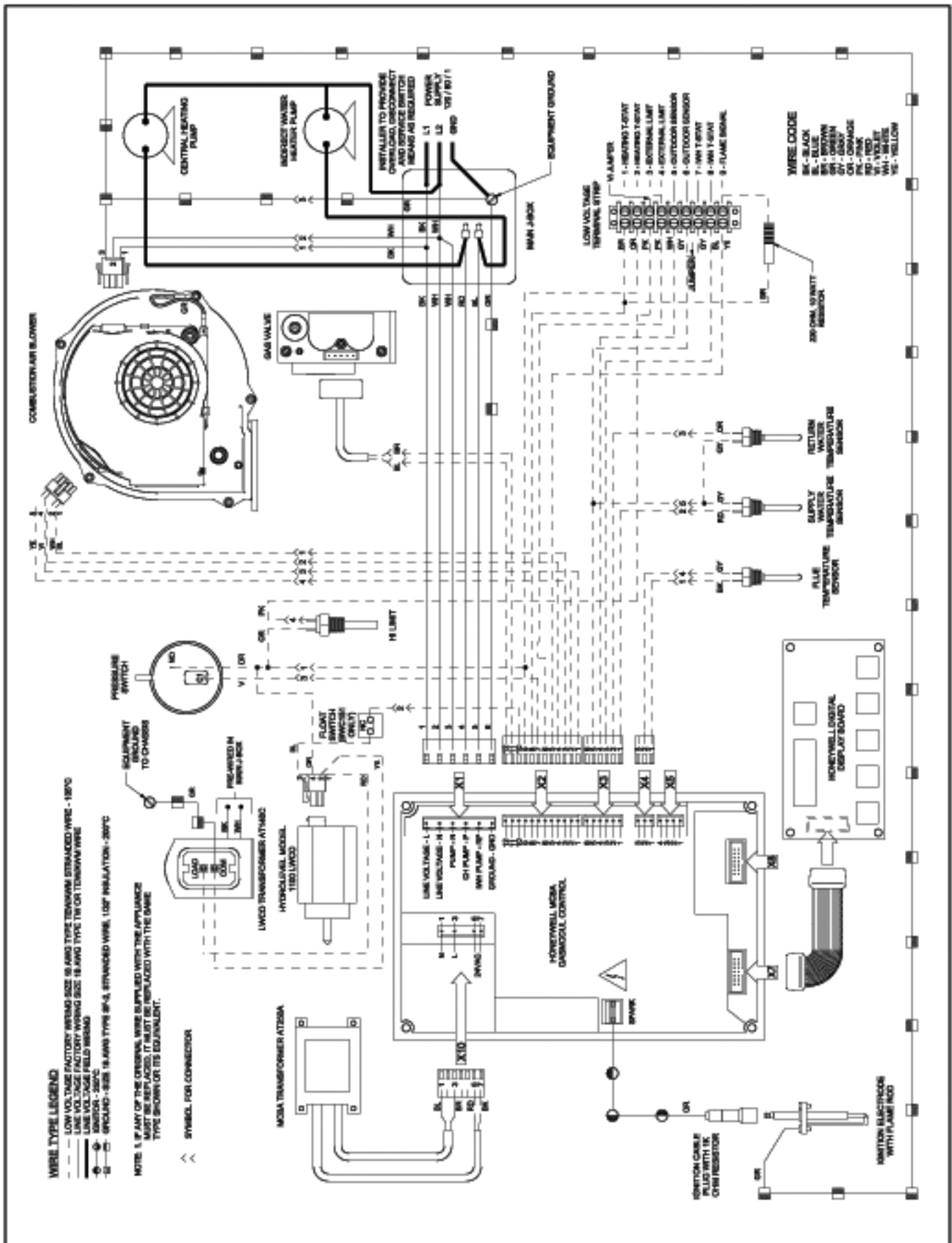

Figure 10.1: Wiring Connections Diagram

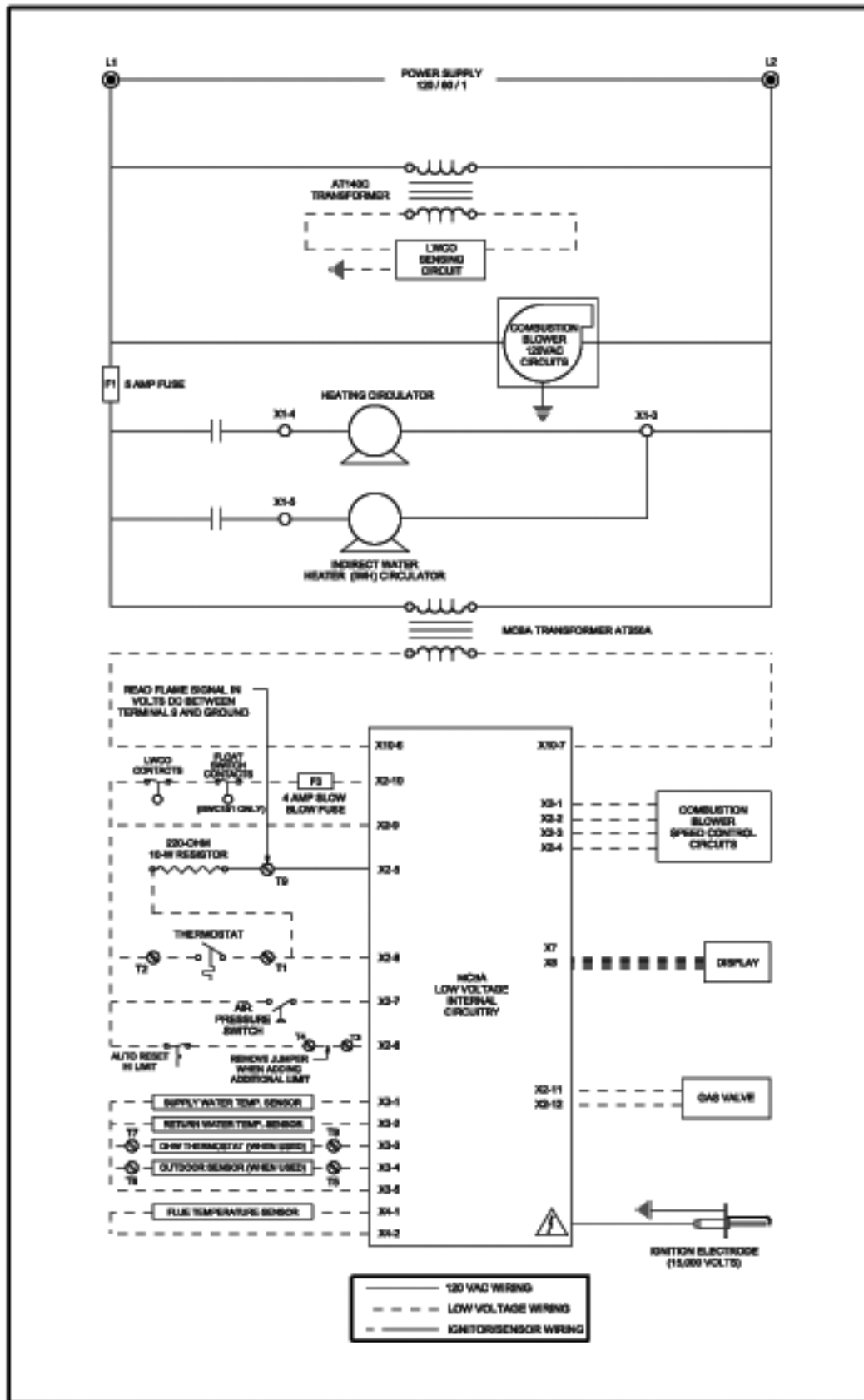

Figure 10.2: Ladder Diagram

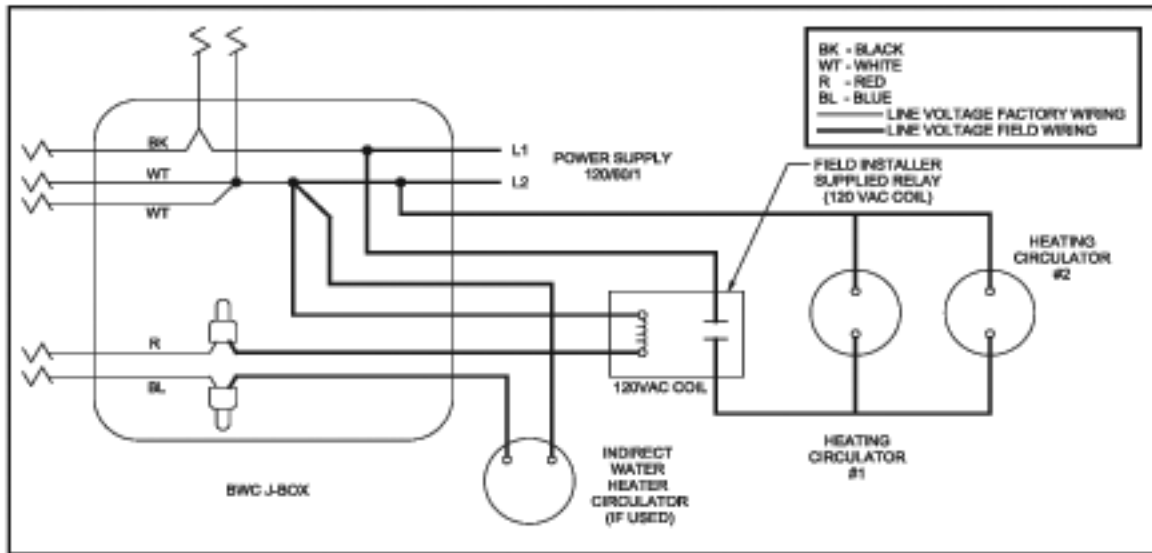

Figure 10.3: Wiring of Isolation Relay for Control of Two Heating Circulators

XI Start-up and Checkout

NOTE

SAFE LIGHTING AND OTHER PERFORMANCE CRITERIA WERE MET WITH THE GAS TRAIN ASSEMBLY PROVIDED ON THE BOILER WHEN THE BOILER UNDERWENT THE TEST SPECIFIED IN Z21.13.

Use the following procedure for initial start-up of the boiler:

- 1) If not already done, flush the system to remove sediment, flux, and traces of boiler additives. This should be done with the boiler isolated from the system.
- 2) Fill the boiler and hydronic system with water meeting the following requirements below (also see the note on the next page):

pH between 6.5 and 8.5
Total Solids less than 2500 PPM
Hardness less than 120 PPM (7 Grains/Gallon)
Pressurize the system to at least 12 psi at the boiler

WARNING

NEVER ATTEMPT TO FILL A HOT EMPTY BOILER

- 3) Check all new piping for leaks and purge piping sections that are filled with air. See the National Fuel Gas Code for additional information on testing and purging gas lines.

WARNING

- NEVER USE A FLAME TO CHECK FOR GAS LEAKS.
- MAKE SURE THAT THE AREA AROUND THE BOILER IS CLEAR AND FREE FROM COMBUSTIBLE MATERIALS, GASOLINE AND OTHER FLAMMABLE VAPORS AND LIQUIDS.

- 4) Vent system must be complete and free of obstructions before attempting to fire boiler. Make sure that the silicone cure time called for in the vent assembly instructions has passed before firing boiler.
- 5) Inspect all line voltage wiring for loose or uninsulated connections.
- 6) Remove the dust cap from the condensate trap (Fig 7.21). Add water to the trap until water runs out the condensate drain. Reinstall the dust cap.

WATER QUALITY AND BOILER WATER ADDITIVES IMPORTANT NOTE

This boiler is equipped with an aluminum heat exchanger that can be seriously damaged by failure to follow the following guidelines:

1) Flush the system before connecting the boiler - In a replacement installation, flushing the system will remove sediment, solder flux, and traces of old boiler additives. Even if the system is new, do not omit this step - new systems will contain solder flux and may even contain sediment.

2) Make sure that the system is tight - **This is the single most important guideline.** Tap water contains dissolved oxygen which causes corrosion. In a tight system, this oxygen comes out of solution and is quickly removed from the system through the automatic air vent. The system then remains essentially free of oxygen. If the system is not tight, however, frequent additions of make-up water can expose the heat exchanger to oxygen on a continuous basis. In addition, frequent additions of hard make-up water can cause calcium deposits to collect in the heat exchanger, causing severe damage.

To minimize additions of make-up water:

- Inspect the system thoroughly for leaks before placing it in service.
- If the system includes underground piping, or other piping in which a leak might go undetected, consider isolating the boiler from the system with a heat exchanger. Alternatively, consider installing a water meter in the fill line to record additions of make-up water.
- Make sure that the expansion tank is properly sized and in good condition. If it is not, the relief valve may open frequently, resulting in regular additions of make-up water.

3) Radiant Tubing and Oxygen Barriers - Even if the system is tight, oxygen can be introduced into the system through some types of non-metallic tubing used in radiant or snow melt systems. Other non-metallic tubing is equipped with an oxygen barrier to prevent migration of oxygen into the water. If the boiler is to be installed in a system containing non-metallic tubing without an oxygen barrier, it must be isolated from the boiler with a heat exchanger as shown in Figure 9.10.

4) Antifreeze - Do not use antifreeze unless absolutely necessary. If antifreeze must be used, the only permitted antifreezes are:

- Fernox Alpha-11
- Fernox CHP in USP Grade virgin propylene glycol (available from Crown)
- RhoGard Aluminum Safe Multi-Metal Antifreeze

When any of the above antifreezes are used, test the boiler water on an annual basis to ensure that the antifreeze remains non-corrosive. For Alpha-11 and CHP in propylene glycol this is done with Fernox test kit I-TK (available from Crown). For other approved brands of antifreeze, consult the antifreeze manufacturer for the recommended means of testing the antifreeze.

5) Other Antifreezes and Boiler Additives - Do not add other additives unless they are specifically approved in writing by Crown for use with this boiler. This includes other "aluminum safe" antifreezes.

6) System PH - Maintain the PH in the system between 6.5 and 8.5.

FOR YOUR SAFETY READ BEFORE LIGHTING

WARNING: If you do not follow these instructions exactly, a fire or explosion may result causing property damage, personal injury or loss of life.

- A. This appliance does not have a pilot. It is equipped with an ignition device which automatically lights the burner. Do not try to light the burner by hand.
- B. BEFORE OPERATING smell all around the appliance area for gas. Be sure to smell next to the floor because some gas is heavier than air and will settle on the floor.
- WHAT TO DO IF YOU SMELL GAS**
- Do not try to light any appliance.
 - Do not touch any electric switch; do not use any phone in your building.
 - Immediately call your gas supplier from a neighbor's phone. Follow the gas supplier's instructions.
- C. Use only your hand to turn the gas control knob. Never use tools. If the knob will not push in or turn by hand, don't try to repair it, call a qualified service technician. Force or attempted repair may result in a fire or explosion.
- D. Do not use this appliance if any part has been under water. Immediately call a qualified service technician to inspect the appliance and to replace any part of the control system and any gas control which has been under water.
- If you cannot reach your gas supplier, call the fire department.

OPERATING INSTRUCTIONS

1. STOP! Read the safety information above on this label.
2. Set the thermostat to the lowest setting.
3. Turn off all electric power to the appliance.
4. This appliance is equipped with an ignition device which automatically lights the burner. Do not try to light the burner by hand.
5. Remove the front door panel and the upper boiler access panel.
6. Turn the external boiler manual gas valve T-handle counterclockwise to open gas supply. 
7. Smell for gas in the boiler enclosure. If you smell gas, STOP! Follow "B" in the safety information above. If you don't smell gas, go to the next step.
8. Turn on all electric power to the appliance.
9. Set the thermostat to the desired setting.
10. The first digit of the control display panel will show a series of numbers that indicate the boiler control sequence. The number 3 or 4 means the burner is firing. The number 0 means there is no call for heat from the thermostat or the domestic water heater.
11. If the appliance will not operate, follow the instructions "To Turn Off Gas To Appliance" below and call your service technician or gas supplier.
12. Replace the upper boiler access panel and the front door panel.

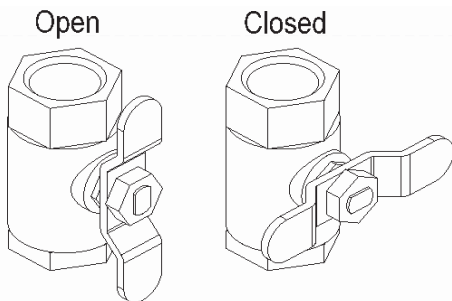

External Boiler Manual Gas Valve

TO TURN OFF GAS TO THE APPLIANCE

1. Turn off all electric power to the appliance if service is to be performed.
2. Set the thermostat to the lowest setting.
3. Turn the external boiler manual gas valve T-handle clockwise to close the gas supply. 
4. Replace the upper boiler access panel and the front door panel.

- 7) Start the boiler using the lighting instructions on page 48. After the boiler is powered up, it should go through the following sequence.

Sequence	Display	Meaning
1	<i>U.125</i> or Blank	Checking internal software (power-up only)
2	<i>0.5WT</i>	Boiler in standby. <i>5WT</i> = Supply Water Temp. No call for heat. (After call for heat from heating thermostat)
3	<i>R.5WT</i>	Self-Check on Start-up
4	<i>S.5WT</i>	Blower and circulator on. Checking for adequate air flow.
5	<i>I.5WT</i>	Prepurge.
6	<i>2.5WT</i>	Trial for ignition.
7	<i>3.5WT</i>	Flame established. Boiler responding to a call for heat.

- 8) Upon initial start-up, the gas train will be filled with air. Even if the gas line has been completely purged of air, it may take several tries for ignition before a flame is established. If more than 5 tries for ignition are needed, it will be necessary to press the reset button to restart the boiler. Once a flame has been established for the first time, subsequent calls for burner operation should result in a flame on the first try.
- 9) Inspect the flame visible through the window. On high fire the flame should be stable and mostly blue (Fig. 11.1). No yellow tipping should be present; however, intermittent flecks of yellow and orange in the flame are normal.

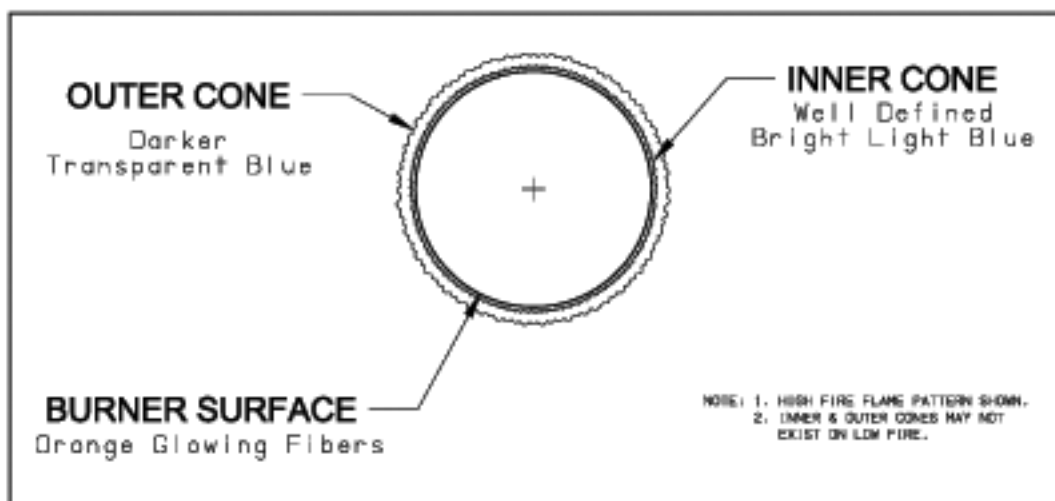

Figure 11.1: Burner Flame

- 10) Check the inlet pressure and adjust if necessary. Verify that the inlet pressure is between the upper and lower limits shown on the rating plate with all gas appliances on and off.

WARNING

THE OUTLET PRESSURE FOR THE GAS VALVE HAS BEEN FACTORY SET AND REQUIRES NO FIELD ADJUSTMENT. THIS SETTING IS SATISFACTORY FOR BOTH NATURAL GAS AND PROPANE. ATTEMPTING TO ADJUST THE OUTLET PRESSURE MAY RESULT IN DAMAGE TO THE GAS VALVE AND CAUSE PROPERTY DAMAGE, PERSONAL INJURY OR LOSS OF LIFE.

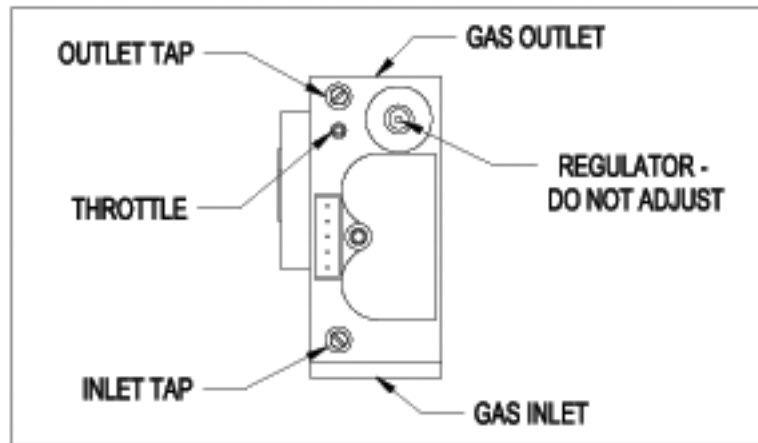

Figure 11.2: Gas Valve Detail

- 11) Perform a combustion test. Boilers equipped with a concentric vent system have a flue gas sample tap located in the boiler vent collar (under the screw cap). For other vent systems, the sample probe may be inserted into the terminal. If this is not possible, remove the flue temperature sensor and insert the analyzer probe in the sensor opening. For the boiler to operate, this sensor will need to be remain connected to the wiring. If the flue gas sensor is removed, be sure to replace it after combustion testing is complete.

Check CO₂ (or O₂) and CO at both high and low fire. The boiler may be temporarily locked into high or low fire for 15 minutes as follows:

- a) To lock the boiler in high fire, simultaneously press and hold the "Mode" button and "+" button until the display flashes "H", indicating that the boiler has been driven to high fire. After this happens, allow the boiler to operate for approximately 5 minutes before taking combustion readings.
- b) To lock the boiler in low fire, simultaneously press and hold the "Mode" button and "-" button until the display flashes "L", indicating that the boiler has been driven to low fire. After this happens, allow the boiler to operate for approximately 5 minutes before taking combustion readings.
- c) Normal modulation of the boiler should return 15 minutes after the boiler is locked in high or low fire.

At both high and low fire, CO readings should be less than 75 PPM. Typical CO₂ and O₂ readings are shown in Table 11.3.

Model	Fuel	%CO ₂	%O ₂
BWC070	Natural Gas	9.4	4.4
BWC070	Propane	10.4	5.1
BWC090	Natural Gas	9.5	4.3
BWC090	Propane	10.5	5.0
BWC120	Natural Gas	9.5	4.3
BWC120	Propane	10.5	5.0
BWC151	Natural Gas	9.5	4.3
BWC151	Propane	10.5	5.0

Table 11.3: Typical CO₂/O₂ Combustion Readings

WARNING

EACH BWC SERIES BOILER IS TESTED AT THE FACTORY AND ADJUSTMENTS TO THE AIR-FUEL MIXTURE ARE NORMALLY NOT NECESSARY. CONSULT A CROWN REPRESENTATIVE BEFORE ATTEMPTING TO MAKE ANY SUCH ADJUSTMENTS. IMPROPER GAS VALVE OR MIXTURE ADJUSTMENTS COULD RESULT IN PROPERTY DAMAGE, PERSONAL INJURY, OR LOSS OF LIFE.

- 12) Test any external limits or other controls in accordance with the manufacturer's instructions.
- 13) Verify that the boiler starts and stops in response to calls for heat from the heating thermostat and indirect water heater thermostat. Make sure that the appropriate circulators also start and stop in response to the thermostats.
- 14) As shipped, the heating and indirect water heater set point supply temperatures are both set to 180°F. If necessary, adjust these to the appropriate settings for the type of system to which this boiler is connected. See the Operation section of this manual for information on how to do this.
- 15) Adjust the heating and indirect water heater thermostats to their final set points.

XII Operation

- 1) The BWC boiler uses a microprocessor based control, known as a "MCBA", to manage all boiler functions including flame supervision and modulation. Two set point or "target" boiler supply temperatures are stored in the MCBA's memory; one for space heating and one for domestic water production. If an outdoor temperature sensor is connected to the boiler, the space heating supply set point will automatically adjust downwards as the outdoor temperature increases. For more information on this feature see the discussion on boiler water reset below.

The MCBA modulates the boiler input by varying the fan speed. As the fan speed increases, so does the amount of gas drawn into the blower. As a result, a fairly constant air-fuel ratio is maintained across all inputs.

The MCBA determines the input needed by looking at both current and recent differences between the supply temperature and the set point temperature. As the supply temperature approaches the set point temperature, the fan will slow down and the input drop. Depending on the model boiler, the minimum input is between 1/4 and 1/5 of maximum input.

The MCBA also monitors boiler return and flue temperatures. In addition, all other safety controls, including the low water cut-off and safety limit, are connected into the MCBA. The MCBA uses input from all of these controls to either shut down the boiler when an unsafe condition exists or, in some cases, to correct the problem.

- 2) The display panel has three primary modes of operation. These are:
 - Standby Mode – Displays boiler's current status. This is the default operating mode.
 - Parameter Mode – Used to change control settings.
 - Information Mode – Displays boiler operating temperatures.

Under normal conditions, the boiler is in standby mode and the display looks like that shown in Figure 12.1. The three digits to the right of the decimal point are the boiler's supply temperature. The digit to the left of the decimal point is the boiler's status code. A list of status codes, and their meanings, is shown in Table 12.3. Figure 12.2 is a map of the menu structure for the control panel. Push the mode key to move from one mode to the next. As you change modes, the mode you are entering is shown on the display:

- a) "PRM" for Parameter Mode
- b) "Inf" for Information Mode
- c) "Stby" for Standby Mode. Upon entering standby mode, "Stby" will briefly appear on the display and then the display will show the boiler's status along with the supply temperature (Figure 12.1).

The control will return to standby mode from any other mode if no key is pressed for 20 minutes.

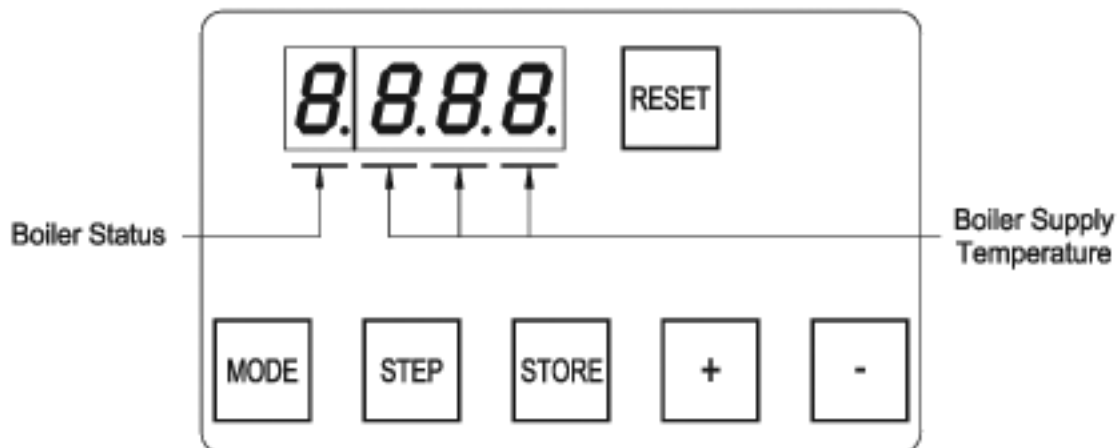

Figure 12.1: Normal Display In Standby Mode

In standby mode, it is possible to view both the heating supply set point temperature and the “domestic hot water reference set point”. The “domestic hot water reference set point” plus 45°F equals the boiler supply set point when it is responding to a call from the indirect water zone. It is not the actual domestic hot water set point. The BWC is designed for use with a storage type indirect water heater such as the Crown Mega-Stor. The domestic water set point is controlled by the thermostat on the indirect water heater. The “default domestic water reference set point” is 135°F and target boiler supply temperature when responding to a call from the indirect water heater is therefore 180°F (135°F +45°F). The default heating supply set point (parameter 4) is 180°F.

In standby mode it is also possible to turn on or off either the heating or domestic water zone. There is normally no reason to turn off either of these zones and doing so is not recommended.

CAUTION

PUSHING AND HOLDING THE “+” WHILE IN STANDBY MODE WILL PREVENT THE BOILER FROM RESPONDING TO A CALL FOR HEAT. PUSHING AND HOLDING THE “-” WHILE IN STANDBY MODE WILL PREVENT THE BOILER FROM RESPONDING TO A CALL FOR DOMESTIC WATER. IF THIS HAPPENS, “cOFF” or “dOFF” WILL APPEAR ON THE DISPLAY. TO TURN BACK ON THE HEATING FUNCTION, PRESS AND HOLD “+” UNTIL “c” AND THE SET POINT TEMPERATURE APPEARS ON THE DISPLAY. TO TURN BACK ON THE DOMESTIC WATER FUNCTION, PRESS AND HOLD “-” UNTIL “d” AND THE SET POINT TEMPERATURE APPEARS ON THE DISPLAY. AFTER PRESSING ANY KEYS, AND BEFORE LEAVING THE INSTALLATION, VERIFY THAT THE BOILER FIRES IN RESPONSE TO A CALL FOR HEAT AND DOMESTIC WATER.

In standby mode, if “Mode” and either “+” or “-“ are simultaneously pushed and held for at least 2 seconds, the burner can be forced into either high or low fire. This feature is used for running combustion tests. After 15 minutes, the burner will automatically revert to modulation. If it is desired to revert to modulation before 15 minutes has passed, simultaneously pushing “+” and “-“ will restore modulation.

In Parameter mode both set points can be changed and both zones turned on or off. In addition, both zones can be configured for continuous pump operation. If the heating zone is set for continuous pump operation (parameter 3 set to 3), the heating pump will still shut down when there is a call for domestic hot water.

If either the heating supply set point (parameter 4) , or the DHW reference set point (parameter 1) are set above their factory set values, the boiler supply temperature will exceed 180°F and there is a possibility that the safety temperature limit will open. If this happens, the boiler will shut down and a “b26” error will appear on the display. The boiler will resume normal operation without manual intervention when the safety limit closes (this behavior is common on conventional boilers).

Information mode is used to view various temperatures and settings but cannot be used to change parameters or otherwise control the boiler. The information available is shown in Figure 12.2 and is largely self-explanatory. The digit to the left of the decimal point is the Step number and the digits to the right are the corresponding temperature.

In information mode, the “supply water temperature set point” (Step 6) is the supply temperature set point for the zone to which the boiler is currently responding (either heat or DHW). If an outdoor sensor is connected to the boiler, and the boiler is responding to a call for heat, this value will be the current point on the reset curve. When no call for heat or DHW is present, Step 6 shows the heating supply set point.

In some cases a “-22” will appear in Information Mode for a particular reading. This means that the reading is not applicable. For example, “-22” will appear for the outdoor temperature (Step 4) if no outdoor sensor is connected to the boiler.

FIGURE 12.2 BASIC MENU TREE

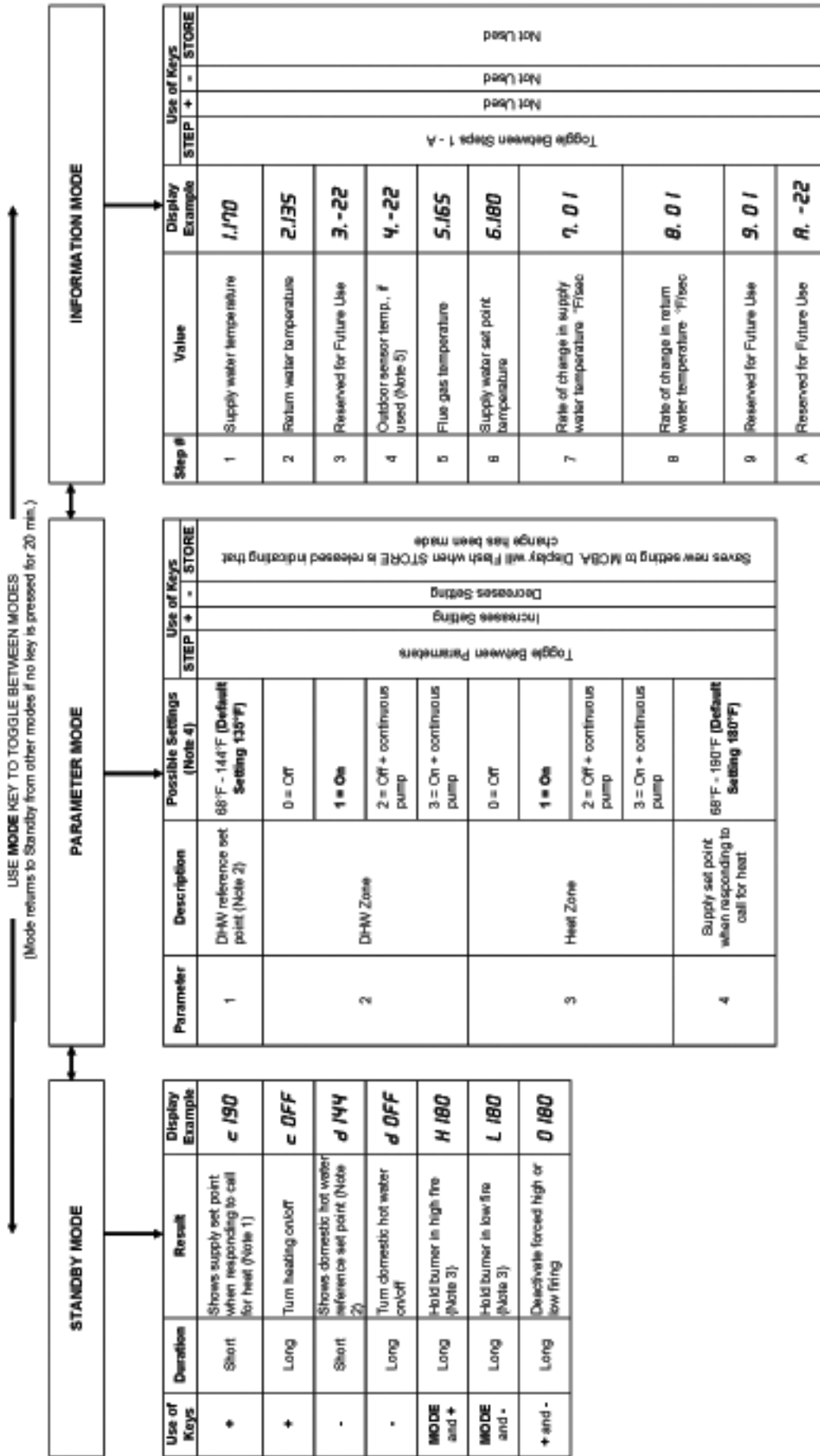

Notes

- 1) If outdoor sensor is connected, this temperature is the supply temperature setpoint when the outdoor temperature is 0°F.
- 2) "Domestic water reference set point" + 45°F = boiler supply set point when boiler is responding to a call for domestic hot water (default = 180°F).
- 3) Boiler will automatically resume modulation after 15 minutes.
- 4) Factory default settings are shown in bold.
- 5) If no outdoor sensor is connected, display reads "4.-22".

3) Two basic types of errors codes are shown on the display:

- **Soft Lockout Codes** – When a soft lockout occurs, the boiler will shut down and the display will alternate between the number “9” and the letter “b” followed by a two digit service code. A list of these codes, and their meanings, is shown in Table 14.3. The boiler will automatically restart once the condition that caused the lockout is corrected.
- **Hard Lockout Codes** – When a hard lockout occurs, the boiler will shut down and the display will flash the letter “E” followed by a two digit service code. A list of these codes, and their meanings, is shown in Table 14.4. Once the condition that caused the lockout is corrected, the boiler will need to be manually reset using the RESET button on the display.

First Digit	Boiler Status
0	Burner off - No call for heat or DHW
1	Pre-purge or post-purge
2	Ignition
3	Burner responding to call for heat
4	Burner responding to call for DHW
5	Checking air pressure switch
6	Burner off - Set point temperature has been reached
7	Call for heat ended. 10s heating post pump period
8	Call for DHW ended. 10s DHW post pump period
9 and b Flashing	Burner off - on soft lockout. See Troubleshooting Section to determine meaning of error code.
A	Boiler responding to call from heating zone
H	Burner on - Held in high fire
L	Burner on - Held in low fire

Table 12.3: Boiler Status

- 4) If an outdoor sensor is installed, the boiler will automatically adjust the heating zone set point temperature based on the outdoor reset curve in Figure 12.4. The maximum set point is defined by parameter 4 (factory set to 180°F) when the outdoor temperature is 0°F or below. The minimum set point temperature shown is 130°F when the outdoor temperature is 60°F or above. As the outdoor temperature falls, the supply water target temperature increases. For example, if the outdoor air temperature is 30°F, the set point temperature for the supply water is 155°F.
- 5) An indirect water heater thermostat can be connected between terminals 7 and 8 on the terminal strip. When this thermostat closes, the central heating circulator will be turned off and the DHW circulator will be turned on.
- 6) An external limit control can be installed between terminals 3 and 4 on the terminal strip. Be sure to remove the jumper between terminals 3 and 4 when adding an external limit control to the system. If the external limit opens, the boiler will shut down and error code “b 26” will be displayed. If the limit installed is a manual reset type, it will need to be reset before the boiler will operate.

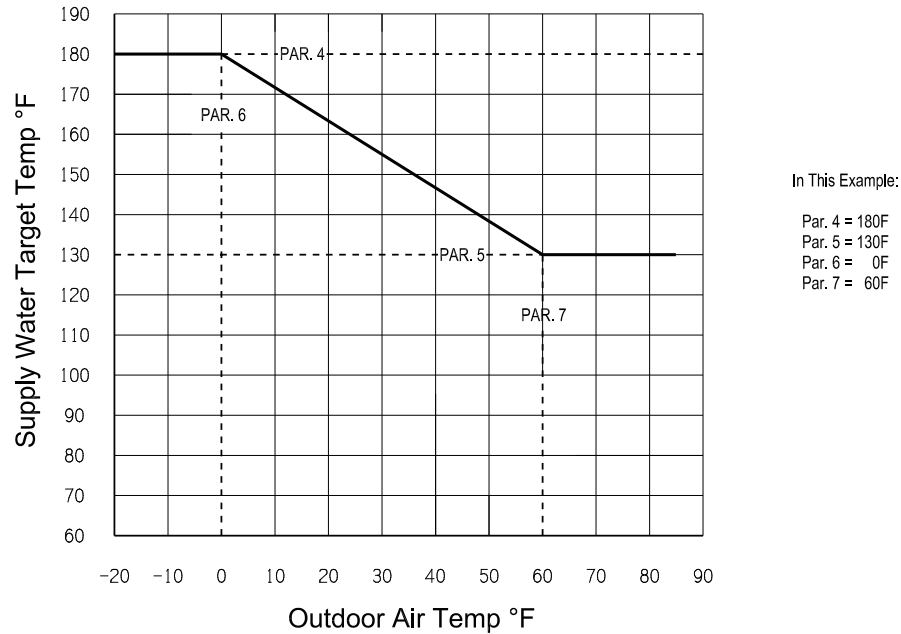

Figure 12.4: Outdoor Reset Curve

- 7) The sequence of operation for a BWC series boiler on a call for heat from a thermostat is as described below:
- a) When power is first turned on, 120V is provided to the MCBA, the combustion fan and the LWCO transformer. A separate 50VA transformer, connected directly to the MCBA, powers all other low voltage circuits.
 - b) For the first few seconds after power-up the control module goes through a self check.
 - c) When there is a call for heat, the control module checks to make sure the air pressure switch is open. If it is, the combustion fan will be energized and will ramp up to ignition speed. When the air pressure switch closes, a 10 second prepurge is activated.
 - d) After the prepurge, the control module energizes the gas control valve and the spark for 4.5 seconds. If a flame is established and proved, the control allows the flame to stabilize for 5 seconds at the combustion fan ignition speed setting. If the flame fails to prove, the control module will attempt to light the burner 4 more times. If a flame is still not established, the control will lockout.
 - e) Once the flame stabilization period has ended, the MCBA allows the burner to modulate. The actual firing rate is dependent upon the measured current and recent differences between the set point temperature and the supply temperature. If an outdoor sensor is connected to the control module and the boiler is responding to a call for heat, the set point temperature will be determined by the outdoor reset curve shown in Figure 12.4.
 - f) Once the set point temperature is reached, the MCBA will turn the burner off and allow the combustion fan to operate in postpurge for 35 seconds before it turns off.
 - g) The central heating pump will continue to operate until the room thermostat has been satisfied.
 - h) A demand for domestic hot water (DHW) is given priority on BWC series boilers. If a call for DHW is received while the boiler is responding to a call for heat, the heating circulator is deenergized until the call for DHW is satisfied.

XIII. Service and Maintenance

IMPORTANT

WARRANTY DOES NOT COVER BOILER DAMAGE OR MALFUNCTION IF THE FOLLOWING STEPS ARE NOT PERFORMED AT THE INTERVALS SPECIFIED.

1) Continuously:

- a. Keep the area around the boiler free from combustible materials, gasoline and other flammable vapors and liquids.
- b. Keep the area around the combustion air inlet terminal free from contaminants.
- c. Keep the boiler room ventilation openings open and unobstructed.

2) Monthly Inspections:

- a. Inspect the vent piping and outside air intake piping to verify they are open, unobstructed and free from leakage or deterioration. Call the service technician to make repairs if needed.
- b. Inspect the condensate drain system to verify it is leak tight, open and unobstructed. Call the service technician if the condensate drain system requires maintenance.
- c. Inspect the water and gas lines to verify they are free from leaks. Call the service technician to make repairs if required.

CAUTION

WATER LEAKS CAN CAUSE SEVERE CORROSION DAMAGE TO THE BOILER OR OTHER SYSTEM COMPONENTS. IMMEDIATELY REPAIR ANY LEAKS FOUND.

4) Annual Inspections and Service: In addition to the inspections listed above, the following should be performed by a service technician once every year.

- a. Test the low water cutoff by pressing the "Test" button located at its end. The yellow light should come on and "E12" should flash on the display. Push the reset button on the display to restore normal operation. If the yellow light does not come on, determine why the low water cutoff is not working properly.
- b. Follow the procedure for turning the boiler off found in the BWC Series Lighting and Operating Instructions.
- c. Inspect the wiring to verify the conductors are in good condition and attached securely.

CAUTION

LABEL ALL WIRES PRIOR TO DISCONNECTION WHEN SERVICING CONTROLS. WIRING ERRORS CAN CAUSE IMPROPER AND DANGEROUS OPERATION. VERIFY PROPER OPERATION AFTER SERVICING.

- d. Remove the ignition electrode and inspect it for oxides. Clean the oxides off the electrode with sandpaper. Inspect the ceramic insulator for cracks and replace the ignitor assembly if necessary.
- e. Remove the fan/gas valve assembly from the burner hood. Inspect for lint and dust. If significant lint and dust are found, disassemble the fan/gas valve assembly to expose the swirlplate and fan inlet (see the exploded diagram in the parts list at the back of this manual). Vacuum these parts as required, being careful not to damage the vanes on the swirlplate.
- f. Remove the burner hood to access the burner and the combustion chamber.
- g. Remove the burner and vacuum any dust or lint from the burner. If the burner shows signs of deterioration or corrosion, replace it immediately. Inspect the burner gasket and replace, if necessary.
- h. Inspect the heat exchanger and vacuum any debris found on the pins and other surfaces. Clean the casting pins by flushing with clean water. A soft nylon brush may be used in accessible areas. Drain and flush the inside of the heat exchanger and condensate collector as required. Do not use any cleaning agents or solvents.
- i. Inspect the condensate trap to verify it is open and free from debris. Clean if necessary.
- j. Reinstall the burner, burner hood and fan/gas valve assembly.
- k. Reconnect any wiring which has been disconnected.
- l. Inspect the heating system and correct any other deficiencies prior to restarting the boiler.
- m. Follow Section XI Start-up and Checkout instructions before leaving installation.
- n. Perform the combustion test outlined in Section XI.
- o. Verify that the system PH is between 6.5 and 8.5.
- p. Check for vent terminal obstructions and clean as necessary.

XIV. Troubleshooting

WARNING

TURN OFF POWER TO BOILER BEFORE REPLACING FUSES OR WORKING ON WIRING.

A. Troubleshooting problems where no error code is displayed:

Table 14.1: No Error Code Displayed

CONDITION	POSSIBLE CAUSES
Display Blank, Fan off, LWCO lights off	<ul style="list-style-type: none">No 120VAC Power at boiler. Check breaker and wiring between breaker panel and boiler.
Display Panel Blank, Fan running	<ul style="list-style-type: none">Loose 120VAC connection wiring between boiler J-Box and MCBA.Blown "F1" fuse in MCBA (see Figure 13.2 for location). Replace with 5A fuse provided.
Display reads "U.125" continuously, Fan running	<ul style="list-style-type: none">Defective AT250 transformer.Blown "F3" fuse in MCBA (see Figure 13.2 for location). Replace with 4A slow-blow fuse provided.
Boiler not responding to call for heat, Status code on display = "0" (see Figure 11.1)	<ul style="list-style-type: none">Boiler is not seeing call for heat. Check thermostat or zone wiring for loose connection, miswiring, or defective thermostat/zone control.
Boiler fires, but display panel is blank	<ul style="list-style-type: none">Loose ribbon cable.Defective display.

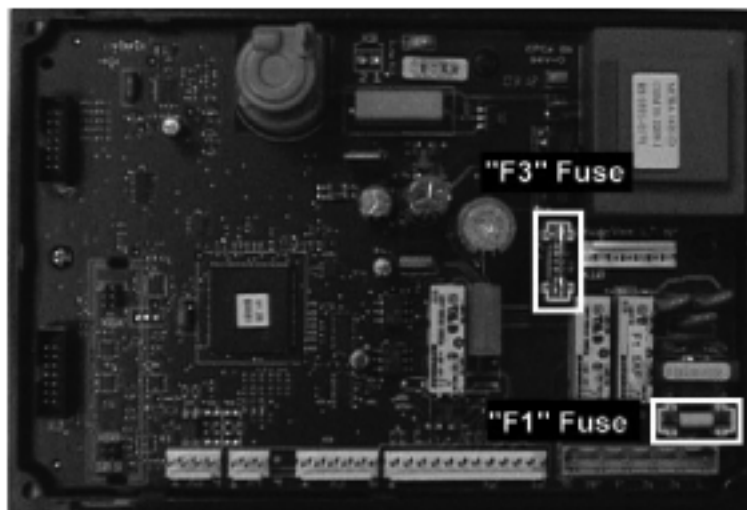

Figure 14.2: MCBA Fuse Location

- B. Trouble shooting problems where a soft lockout code is displayed. When a soft lockout occurs, the boiler will shut down and the display will alternate between the number “9” and the letter “b” followed by a two digit service code. The boiler will automatically restart once the condition that caused the lockout is corrected.

Table 14.3: Soft Lockout Codes Displayed

CODE	CONDITION	POSSIBLE CAUSES
b 08	Pressure switch circuit open.	<ul style="list-style-type: none"> • Blockage in intake or vent system. • Vent and/or intake system not constructed in accordance with Part VII. • Blocked or leaking pressure switch tubing. • Heat exchanger or burner blockage. • Terminals exposed to high winds. • Blockage in condensate trap above vent.
b 18	MCBA supply sensor detected temperatures in excess of 200°F.	<ul style="list-style-type: none"> • Heating load at time of error was far below the minimum firing rate of the boiler. • Defective primary pump or no flow in primary loop (Piping Method 1). • Control system miswired so that boiler operation is permitted when no zones are calling.
b 19	MCBA return sensor detected temperatures in excess of 200°F.	<ul style="list-style-type: none"> • See possible causes for “b18”. • Flow through boiler reversed. • Sensor wiring reversed.
b 24	MCBA is reading a return sensor temperature higher than the supply sensor temperature. Condition must be present for at least 75s for this error code to appear.	<ul style="list-style-type: none"> • Flow through boiler reversed. Verify correct piping and pump orientation. • No boiler water flow. Verify that system is purged of air and that appropriate valves are open. • Sensor wiring reversed. • Supply or return sensor defective.
b 25	Supply water temperature has risen too quickly.	<ul style="list-style-type: none"> • See possible causes for “b18”. • Inadequate boiler water flow. Verify that pump is operating and that pump and piping are sized per Part IX of this manual.
b 26	Boiler safety limit, or external limit wired across terminals 3&4, is open.	<ul style="list-style-type: none"> • See possible causes for “b18”. • Defective supply sensor.
b 30	Temperature rise between supply and return is too high.	<ul style="list-style-type: none"> • Inadequate boiler water flow. Verify that pump is operating and that pump and piping are sized per Part IX of this manual.
b 61	Pressure switch circuit closed with fan off.	<ul style="list-style-type: none"> • Blockage in pressure switch hose. • Pressure switch wires shorted together. • Defective pressure switch. • Loose or miswired fan speed harness (if “b61” error code is observed while fan is running).
b 65	Fan is not achieving set point speed.	<ul style="list-style-type: none"> • Loose or incorrect fan speed control connection. • Defective fan.

- C. Trouble shooting problems where a hard lockout code is displayed. When a hard lockout occurs, the boiler will shut down and the display will flash the letter "E" followed by a two digit service code. Once the condition that caused the lockout is corrected, the boiler will need to be manually reset using the RESET button on the display.

Table 14.4: Hard Lockout Codes Displayed

CODE	CONDITION	POSSIBLE CAUSES
E 00	A flame signal was present when there should be no flame.	<ul style="list-style-type: none"> Defective gas valve - make sure inlet pressure is below maximum on rating plate before replacing valve.
E 02	Flame failure after 5 tries to restart.	<ul style="list-style-type: none"> No gas pressure. Gas pressure under minimum value shown on rating plate. Gas line not completely purged of air. Defective Electrode. Loose burner ground connection. Defective Ignition Cable. Defective gas valve (check for 24 VDC at harness during trial for ignition before replacing valve). Air-fuel mixture out of adjustment - consult factory.
E 03	Gas valve error.	<ul style="list-style-type: none"> Loose or defective gas valve harness. Check electrical connections. Defective gas valve (check for 24 VDC at harness during trial for ignition before replacing valve).
E 04	Power failure occurred after lockout.	<ul style="list-style-type: none"> Some other error on this list occurred and power to the boiler was then interrupted. Reset control and see if hard lockout reoccurs.
E 05 E 06 E 07 E 11	Internal control failure.	<ul style="list-style-type: none"> Reset the control. If problem reoccurs, replace the MCBA.
E 12	Low water cut-off circuit open. Float Switch Open (BWC151 Only)	<ul style="list-style-type: none"> If yellow light on LWCO is on, system is low on water. If neither yellow nor green light is on, check LWCO harness and check for 24VAC across AT140 transformer. Check condensate trap for blockage (BWC151 only)
E 13 E 14 E 15 E 16 E 17	Internal control failure.	<ul style="list-style-type: none"> Reset the control. If problem reoccurs, replace the MCBA.
E 18	MCBA supply sensor detected temperatures in excess of 200°F for an extended period of time	<ul style="list-style-type: none"> See possible causes for "b18" error. Also, check safety limit for proper operation.
E 19	MCBA return sensor detected temperatures in excess of 200°F for an extended period of time	<ul style="list-style-type: none"> See possible causes for "b19" error.
E 28	Blower is not running when it should or fan speed signal not being detected by MCBA.	<ul style="list-style-type: none"> Loose connection in 120 VAC fan wiring. Loose or miswired fan speed harness. Defective fan.
E 29	Blower fan speed has not returned to zero rpm.	<ul style="list-style-type: none"> Miswired fan speed harness. Defective fan.
E 31	Shorted supply temperature sensor.	<ul style="list-style-type: none"> Shorted or miswired supply sensor wiring. Defective supply sensor.
E 32	Shorted return temperature sensor.	<ul style="list-style-type: none"> Shorted or miswired return sensor wiring. Defective return sensor.
E 35	Flue gas temperature sensor short circuit.	<ul style="list-style-type: none"> Shorted or miswired flue temp sensor wiring. Defective flue temp sensor.
E 36	Supply water temperature sensor circuit open.	<ul style="list-style-type: none"> Loose or miswired supply sensor wiring. Defective supply sensor.
E 37	Return water temperature sensor circuit open.	<ul style="list-style-type: none"> Loose or miswired return sensor wiring. Defective return sensor.
E 40	Flue gas temperature sensor circuit open.	<ul style="list-style-type: none"> Loose or miswired flue temp sensor wiring. Defective flue temp sensor.
E 44	Internal control failure.	<ul style="list-style-type: none"> Reset the control. If problem reoccurs, replace the MCBA.
E 52	Flue gas temperature over 230°F.	<ul style="list-style-type: none"> Heat exchanger needs to be cleaned. Boiler over-fired. Air-fuel mixture out of adjustment - consult factory.
E 60	Internal control failure.	<ul style="list-style-type: none"> Reset the control. If problem reoccurs, replace the MCBA.

XV Parts

The following parts may be obtained from any Crown distributor. To find the closest Crown distributor, consult the area Crown representative or the factory at:

Crown Boiler Co.
Customer Service
P.O. Box 14818
Philadelphia, PA 19134
www.crownboiler.com

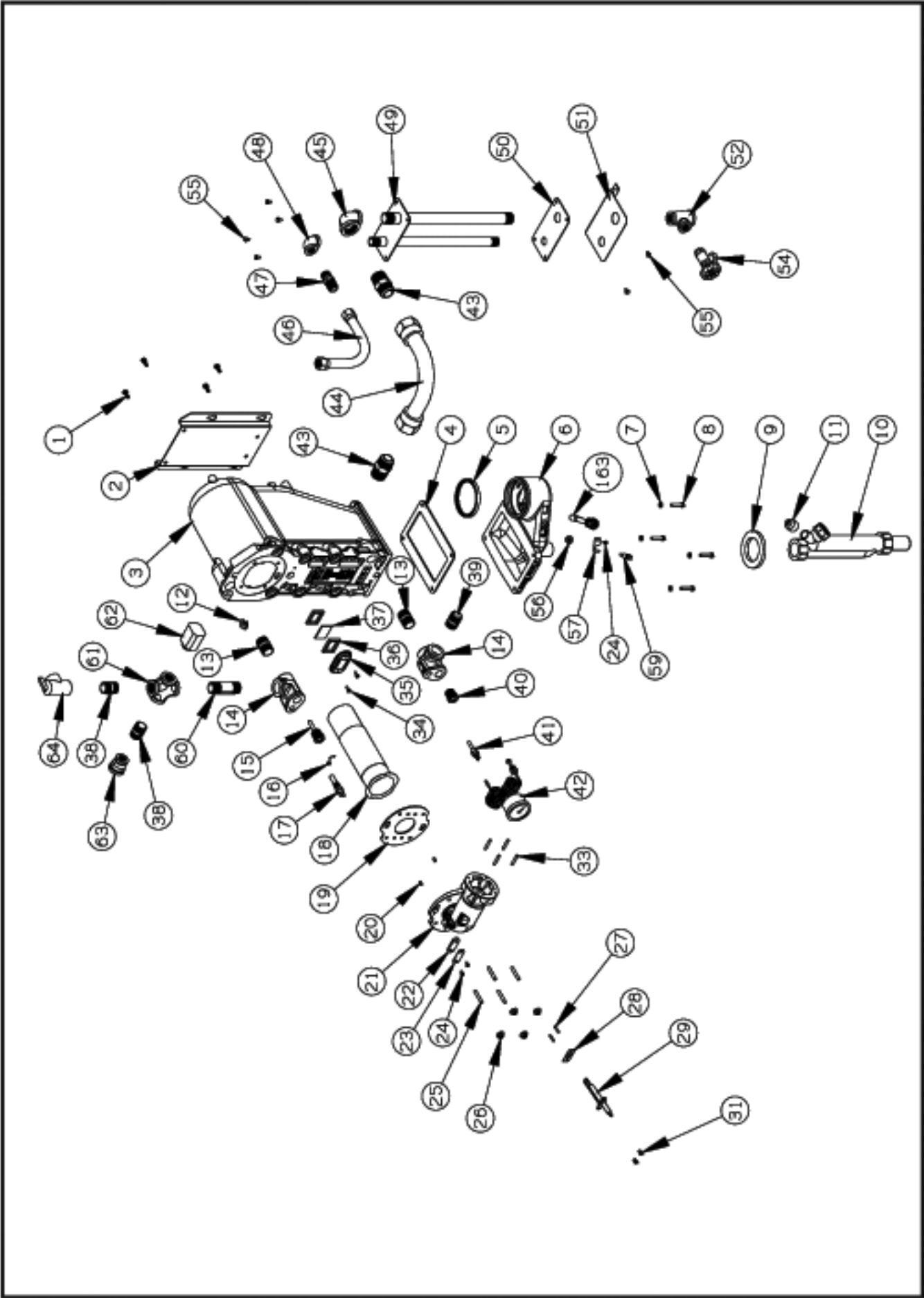

PARTS LIST

Key	DESCRIPTION	BWC070		BWC090		BWC120		BWC151	
		Part #	QTY	Part #	QTY	Part #	QTY	Part #	QTY
*	Taco 008	950165	1						
*	Taco 0014			950160	1	950160	1	950160	1
*	Gas Cock	950615	1	950615	1	950615	1	950615	1
*	M4 x 30mm Machine Screw (for gas valve harness)	3507342	1	3507342	1	3507342	1	3507342	1
*	Outdoor Sensor	240022	1	240022	1	240022	1	240022	1
*	4A Fuse	960004	1	960004	1	960004	1	960004	1
*	5A Fuse	960005	1	960005	1	960005	1	960005	1
*	Nylon Wire Tie Shoe	960016	9	960016	9	960016	9	960016	9
*	Graphic Overlay Membrane	960030	1	960030	1	960030	1	960030	1
*	X5 Plug	9602416	1	9602416	1	9602416	1	9602416	1
1	M6 x 16mm Serrated Flange Head Hex Screw	900722	4	900722	4	900722	4	900722	4
2	AM Heat Exchanger Bracket	230413	1	230413	1	230414	1	230414	1
3	Heat Exchanger	230013	1	230013	1	230014	1	230015	1
4	Sump Gasket	230713	1	230713	1	230714	1	230716	1
5	80mm Vent Gasket	240039	1	240039	1	240039	1	240039	1
6	Sump	230703	1	230703	1	230704	1	230708A	1
7	M6 Washer	230906	4	230906	4	230906	4	230906	4
8	M6 x 30mm Cap Screw	230935	4	230935	4	230935	4	230935	8
9	Condensate Trap Gasket	240005	1	240005	1	240005	1	240005	1
10	Condensate Trap, 150mm	240955	1	240955	1	240955	1	240955	1
11	Red Vinyl Cap	240990	1	240990	1	240990	1	240990	1
12	Supply Temperature Sensor	230122	1	230122	1	230122	1	230122	1
13	3/4 BSP x 1 1/2" Steel Nipple	950140	2	950140	2	950140	2		
13	1" BSP x 1 1/2" Steel Nipple							950141	2
14	Supply/Return Fitting	230095	2	230095	2	230095	2	230095	2
15	Gauge Sensor Well	230102	1	230102	1	230102	1	230102	1
16	Gauge Cap Tube Clamp	230103	1	230103	1	230103	1	230103	1
17	High Limit	960124	1	960124	1	960124	1	960124	1
18	Burner	230035	1	230035	1	230045	1	230046	1
19	Burner Hood Gasket	230032	1	230032	1	230032	1	230032	1
20	5 x 8 Grooved Pin	230945	2	230945	2	230945	2	230945	2
21	Burner hood, AM	230030	1	230030	1	230030	1	230030	1
22	Burner Hood Cover Plate Gasket	230050	1	230050	1	230050	1	230050	1
23	Burner Hood Cover Plate	230051	1	230051	1	230051	1	230051	1
24	M4 X 8 Machine Screw	230923	3	230923	3	230923	3	230923	3
25	M6 x 40mm Set Screw	230940	4	230940	4	230940	4	230940	4
26	M6 Nut With Captive Washer	240905	4	240905	4	240905	4	240905	4
27	M4 x 20mm Set Screw	240820	2	240820	2	240820	2	240820	2
28	Electrode Gasket	240011	1	240011	1	240011	1	240011	1
29	Electrode	240010	1	240010	1	240010	1	240010	1
31	M4 Shoulder Nut	240921	2	240921	2	240921	2	240921	2
33	M5 x 30mm Set Screw	230930	4	230930	4	230930	4	230930	4
34	M4 x 12mm PH Machine Screw	240825	2	240825	2	240825	2	240825	2
35	Sight Glass Holder	240951	1	240951	1	240951	1	240951	1
36	Sight Glass Gasket	240952	2	240952	2	240952	2	240952	2
37	Sight Glass	240950	1	240950	1	240950	1	240950	1
38	3/4 x Cl Blk Nipple	95-105	2	95-105	2	95-105	2	95-105	1
39	3/4 x Cl. Brass Nipple	950135	1	950135	1	950135	1		
40	Gauge Pressure Fitting	230101	1	230101	1	230101	1	230101	1
41	Return Temperature Sensor	230125	1	230125	1	230125	1	230125	1
42	Gauge	230100	1	230100	1	230100	1	230100	1
43	1" ID x 1" NPT CSST Adaptor	230710	2	230710	2	230710	2	230710	2
44	1" Gray Coated CSST, Nut by Nut	230700	1	230700	1	230700	1	230706	1
45	3/4 x 1 Blk Reducing Elbow	950116	1	950116	1	950116	1		
45	1" Blk Elbow							950190	1
46	1/2" Yellow Coated CSST, Nut by Nut	230705	1	230705	1	230705	1	230707	1
47	5/8" OD x 1/2" MPT CSST Adaptor	230715	2	230715	2	230715	2	230715	2

PARTS LIST

Key	DESCRIPTION	BWC070		BWC090		BWC120		BWC151	
		Part #	QTY	Part #	QTY	Part #	QTY	Part #	QTY
48	1/2" Blk Elbow	950049	1	950049	1	950049	1	950049	1
48	Flanged Nipple Assy	950700	1	950700	1	950700	1	950701	1
50	Flanged Nipple Gasket	230401	1	230401	1	230401	1	230405	1
51	Pipe Support Bracket	230470	1	230470	1	230470	1	230480	1
52	3/4 x 1 x 3/4 Reducing Black Tee	950118	1	950118	1	950118	1		
52	1 x 1 x 3/4 Black Tee							950212	1
54	3/4 Boiler Drain	95-041	1	95-041	1	95-041	1	95-041	1
55	#10 x 1/2 sheet metal screw	90-212	36	90-212	36	90-212	36	90-212	36
56	Fluegas Sensor Grommet	230056	1	230056	1	230056	1	230056	1
57	Fluegas NTC Mounting Plate	230055	1	230055	1	230055	1	230055	1
59	Fluegas Temperature Sensor	230120	1	230120	1	230120	1	230120	1
60	3/4 x 3" Nipple	95-027	1	95-027	1	95-027	1		
60	1 x 3" Nipple							950104	1
61	3/4 Black Cross	950130	1	950130	1	950130	1		
61	1" Black Cross							950105	1
62	Hydroleval #1100 LWCO	450600	1	450600	1	450600	1	450600	1
63	3/4 x 1 Black Reducing Coupling	950120	1	950120	1	950120	1		
64	30 psi Relief Valve	95-040	1	95-040	1	95-040	1	95-040	1
65	Blower Gasket	240001	1	240001	1	240001	1	240001	1
66	Blower, RG128/1300-3612	230002	1	230002	1	230002	1	230002	1
67	M5 Locknut	900003	4	900003	4	900003	4	900003	4
68	3 x 63mm Buna-N O-Ring	230003	1	230003	1	230003	1	230003	1
68	Fan Inlet block	230150	1	230150	1	230150	1	230150	1
70	10-32 x 1/8 ID Hose Barb	90-222	1	90-222	1	90-222	1	90-222	1
71	1/8 ID Silicone Tubing (12")	14-008	1	14-008	1	14-008	1	14-008	1
72	Dungs Air Inlet Adaptor Part 2 (male)	3507345	1	3507345	1	3507345	1	3507345	1
73	42.5mm Short Fan Adaptor Plate	3507346	1	3507346	1	3507346	1	3507346	1
74	M4 x 25mm Flat Head Machine screw	900010	3	900010	3	900010	3	900010	3
75	5mm Swirlplate (Blue)	3507337	1	3507337	1				
75	9mm Swirlplate (Red)					9507347	1		
75	12mm Swirlplate (Gray)							3507336	1
76	Dungs Air Inlet Adaptor Part 1 (female)	3507344	1	3507344	1	3507344	1	3507344	1
77	M4 x 10mm FH Machine Screw	900006	4	900006	4	900006	4	900006	4
78	Injector Plate	3507348	1	3507348	1	3507348	1	3507348	1
79	M4 x 25mm Positdrive Hd Screws	900734	3	900734	3	900734	3	900734	3
80	1.5 x 17mm O-Ring	3507348	1	3507348	1	3507348	1	3507349	1
81	7.0mm Orifoe					3507339	1	3507339	1
81	5.0mm Orifoe	3507338	1	3507338	1				
82	GB-WND 055 Head On Gas Valve	3507340	1	3507340	1	3507340	1	3507340	1
83	8-32 x 1/2 HWH type F Self Tapping Screw	900713	6	900713	6	900713	6	900713	6
84	Pressure Switch	230008	1	230008	1	230008	1	230008	1
85	Pressure Switch Bracket	230475	1	230475	1	230475	1	230475	1
86	M4 x 6mm Round Head Machine Screw	900011	2	900011	2	900011	2	900011	2
87	Concentric Vent Collar	230501	1	230501	1	230501	1	230501	1
88	Vent Kit	230500	1	230500	1	230500	1	230580	1
88	Control Box	230331	1	230331	1	230331	1	230331	1
90	Gauge Bracket	950705	1	950705	1	950705	1	950705	1
91	Control Cover	230330	1	230330	1	230330	1	230330	1
92	AT140 Transformer	35-2000	1	35-2000	1	35-2000	1	35-2000	1
93	4 x 4 J-Box	96-055	1	96-055	1	96-055	1	96-055	1
94	4 x 4 J-Box Cover	96-054	1	96-054	1	96-054	1	96-054	1
95	10-32 x 3/8" Ground Screw	148-85-301	1	148-85-301	1	148-85-301	1	148-85-301	1
96	Shutter Bushing	96-050	2	96-050	2	96-050	2	96-050	2
97	AT250 Transformer	3502600	1	3502600	1	3502600	1	3502600	1
98	4-40 x 1/2 HWH type F Self Tapping Screw	900470	8	900470	8	900470	8	900470	8
98	MCBA (Programmed)	3523070MC	1	3523120	1	3523120	1	3523120	1
101	Terminal Strip	960085	1	960085	1	960085	1	960085	1
102	DISP4D	3501600	1	3501600	1	3501600	1	3501600	1
103	Graphic Overlay Mounting Plate	240390	1	240390	1	240390	1	240390	1
104	8-32 Lock Nut	900708	4	900708	4	900708	4	900708	4

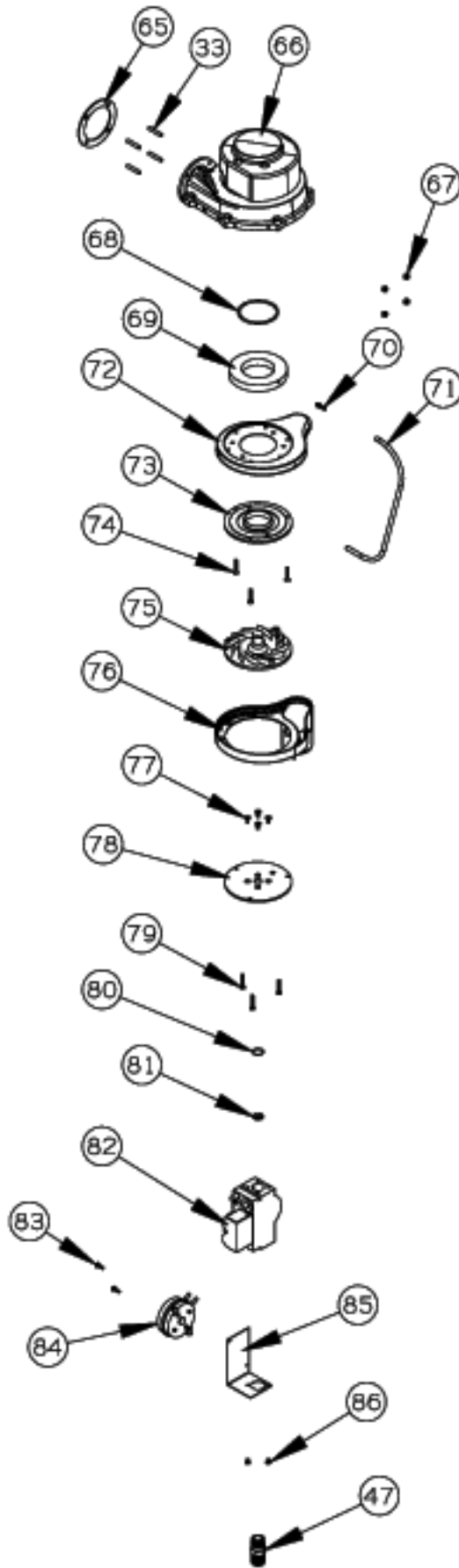

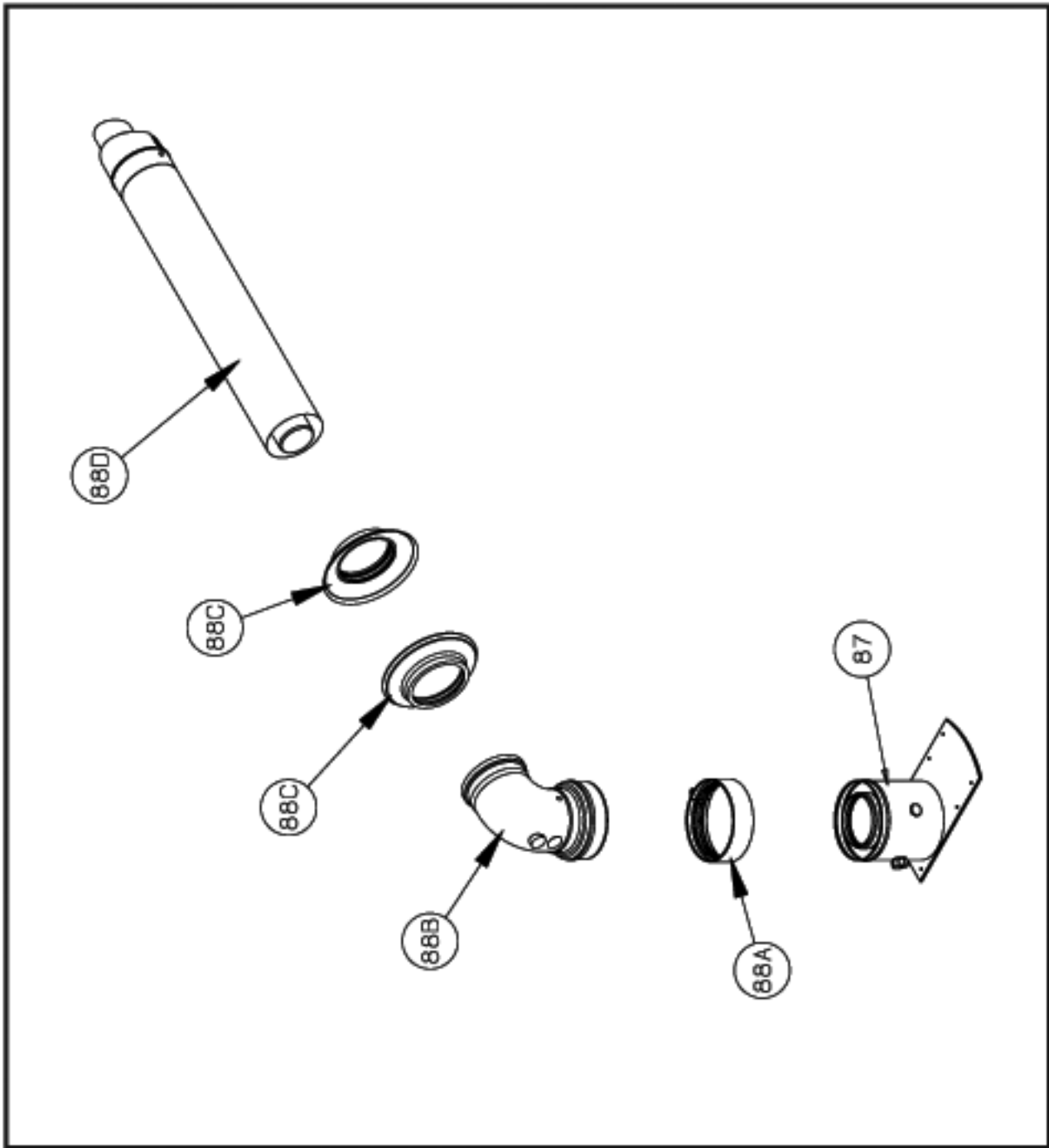

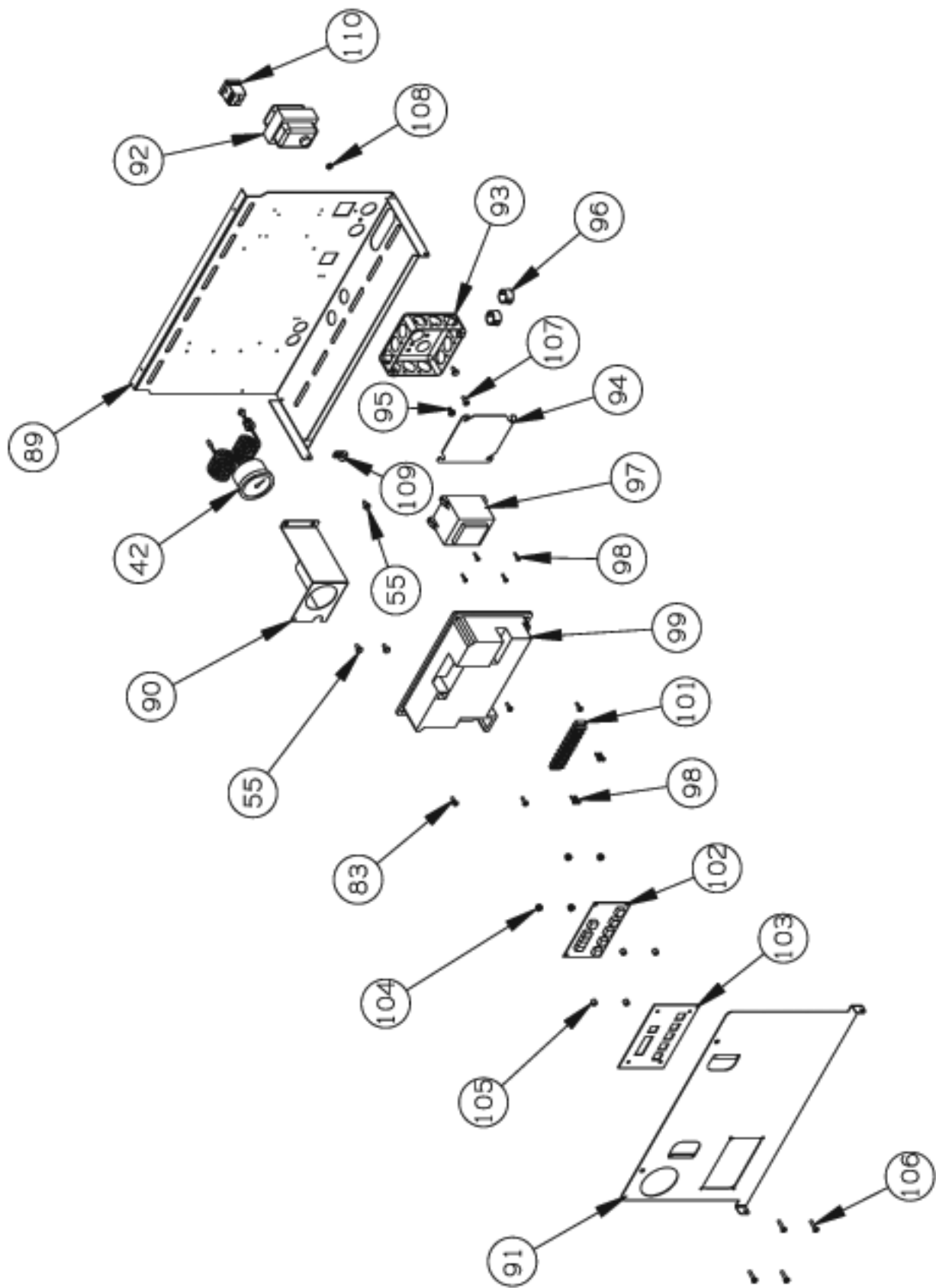

Free Manuals Download Website

<http://myh66.com>

<http://usermanuals.us>

<http://www.somanuals.com>

<http://www.4manuals.cc>

<http://www.manual-lib.com>

<http://www.404manual.com>

<http://www.luxmanual.com>

<http://aubethermostatmanual.com>

Golf course search by state

<http://golfingnear.com>

Email search by domain

<http://emailbydomain.com>

Auto manuals search

<http://auto.somanuals.com>

TV manuals search

<http://tv.somanuals.com>