

CROWN Boiler Co.

D E S I G N E D T O L E A D

JSI & JSE Series

Gas-Fired Natural Draft Steam Boilers

INSTALLATION INSTRUCTIONS

These instructions must be affixed on or adjacent to the boiler

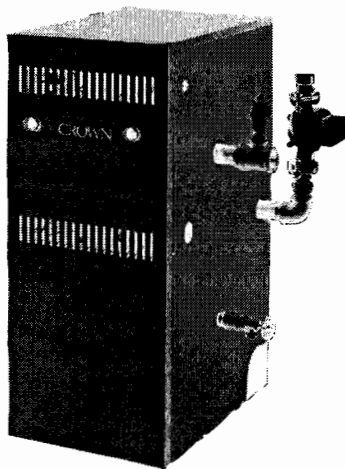

Models:

- JSI069
- JSI103
- JSI138
- JSI172
- JSE207
- JSE241
- JSE276
- JSE310
- JSE345
- JSE379

WARNING: Improper installation, adjustment, alteration, service or maintenance can cause property damage, injury, or loss of life. For assistance or additional information, consult a qualified installer, service agency or the gas supplier. Read these instructions carefully before installing.

CROWN Boiler Co.

Manufacturer of Hydronic Heatings Products
P.O. Box 14818 3633 I. Street

Table of Contents

I. Product Description	1
II. Specifications	2
III. Before Installing	4
IV. Locating the Boiler	4
V. Air for Combustion & Ventilation	5
VI. Venting	9
VII. Gas Piping	13
VIII. System Piping	14
IX. Wiring	17
X. Start-Up & Checkout	23
XI. Service & Maintenance	29
XII. Troubleshooting	32
XIII. Parts	38

I Product Description

The JSI and JSE series boilers are low pressure cast iron gas fired steam boilers designed for use in closed steam heating systems. These boilers are a Category I draft diverter equipped appliances, which must be vented by natural draft using a lined masonry or listed metal chimney system. An adequate supply of air for combustion, ventilation and dilution of flue gases must be available in the boiler room. These boilers are not designed for use in process or other “open” steam systems

The JSI series boiler is equipped with an integral (“built in”) draft diverter. The JSE is supplied with an external draft hood which must be installed without alteration.

II Specifications

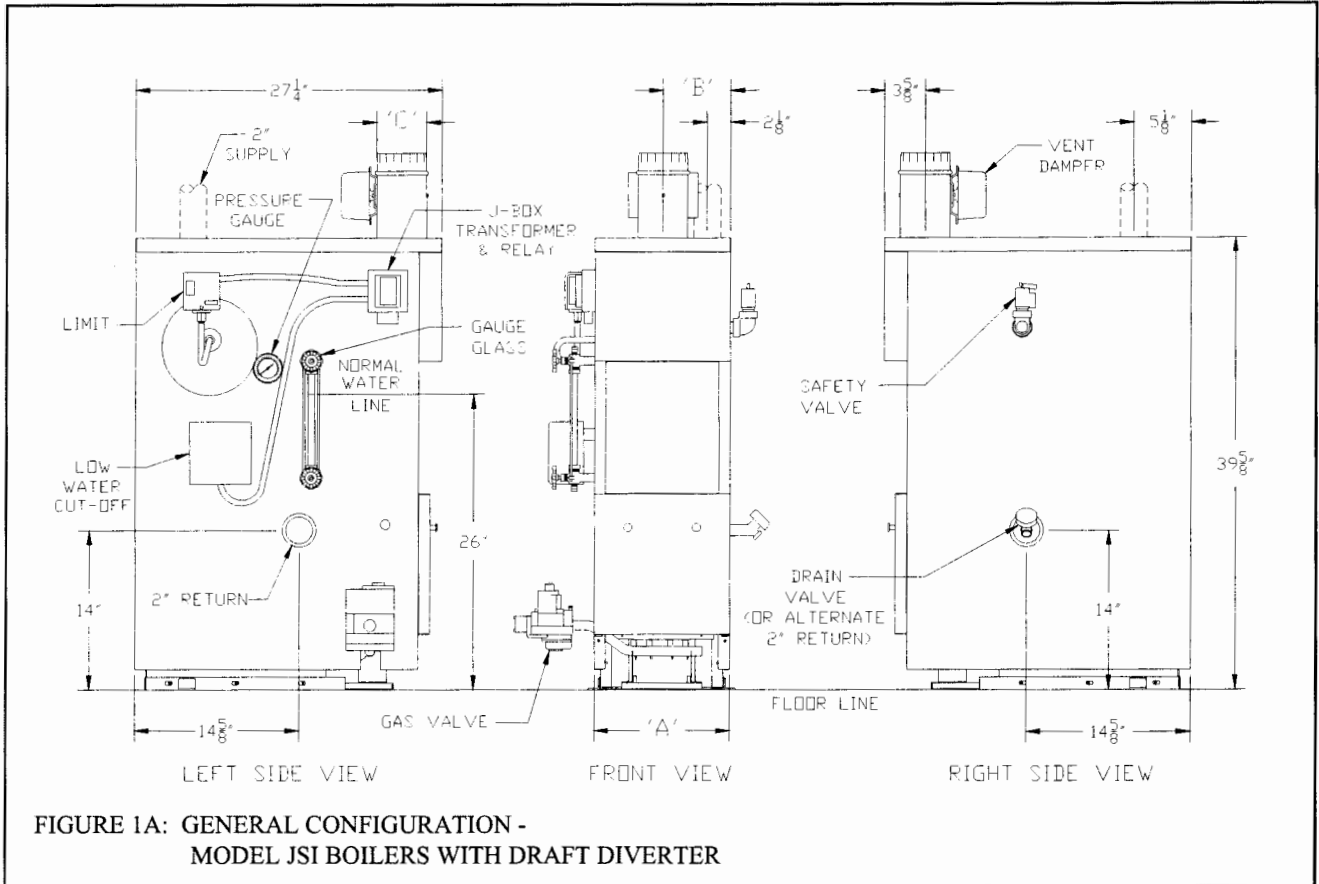

TABLE 1a: JSI SPECIFICATIONS

BASIC BOILER MODEL	RATINGS - NATURAL AND LP GASES*						DIMENSIONS (INCHES)		
	NUMBER OF SECTIONS	INPUT	DOE HEATING CAPACITY	I=B=R NET RATING, STEAM		AFUE	"A"	"B"	"C"
		MBH	MBH	Sq. Ft.	MBH	%			
JSI069S JSI069E	3	69	56	175	42	79.5 81.4	12-1/8	6-1/8	4
JSI103S JSI103E	4	103	84	263	63	80.0 81.4	15-3/4	7-7/8	5
JSI138S JSI138E	5	138	112	350	84	80.1 81.4	19-1/4	9-5/8	6
JSI172S JSI172E	6	172	140	438	105	80.2 81.4	22-3/4	11-3/8	6

Suffix E = Intermittent Ignition, Suffix S = Standing Pilot. Add Suffix N for Natural Gas or Suffix L for Propane Gas to basic JSI model number (example: JSI069SN, JSE069SL)

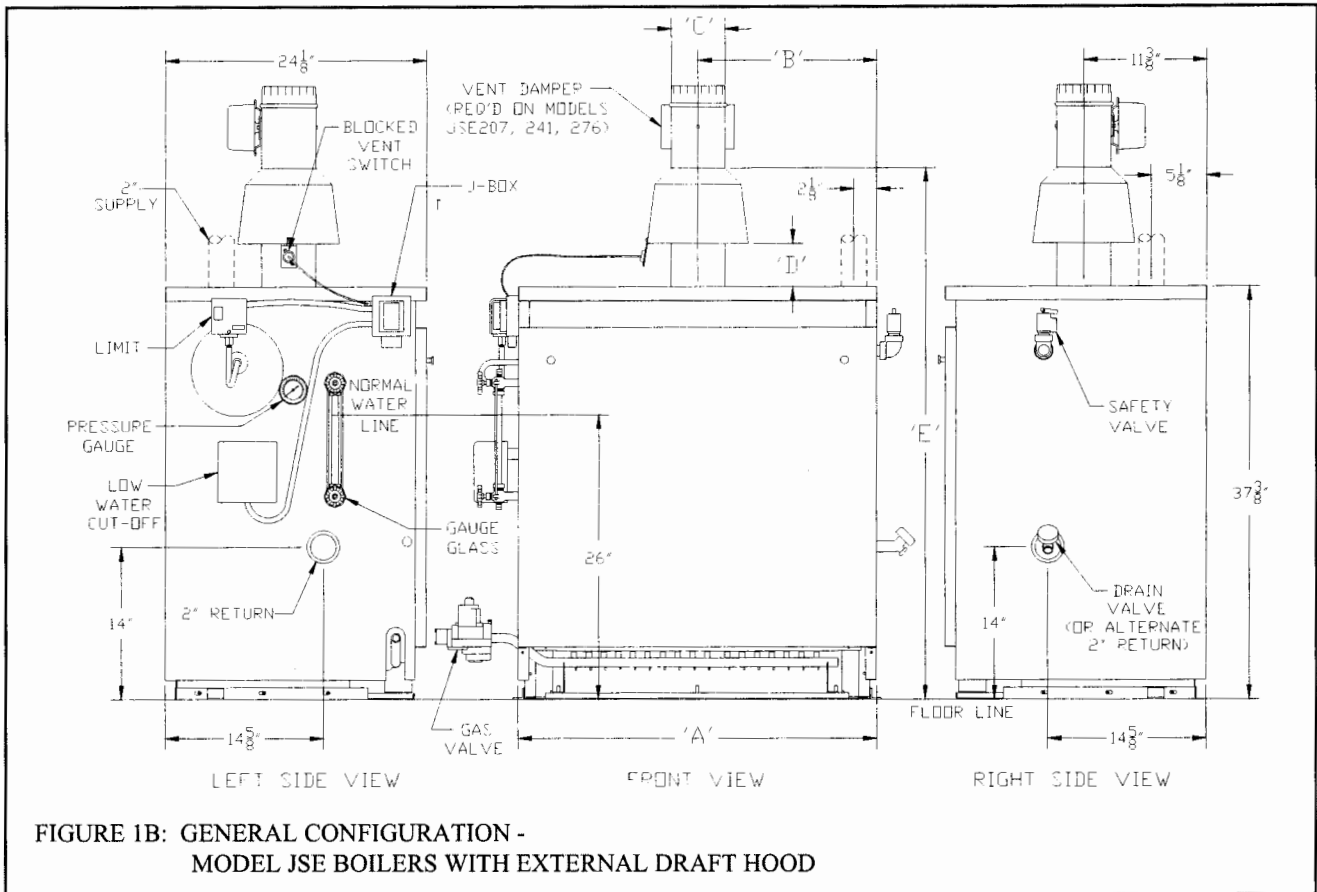

TABLE 1b: JSE SPECIFICATIONS

BASIC BOILER MODEL	RATINGS - NATURAL AND LP GASES*						DIMENSIONS (INCHES)						
	NUMBER OF SECTIONS	INPUT	DOE HEATING CAPACITY	I=B=R NET RATING, STEAM		AFUE	"A"	"B"	"C"	"D"		"E"	
		MBH	MBH	Sq. Ft.	MBH	%				NAT	LP	NAT	LP
JSE207S JSE207E	7	207	169	529	127	80.3 81.5	26-1/2	13-1/4	7	9-3/4	12-3/4	55-7/8	58-7/8
JSE241S JSE241E	8	241	196	612	147	80.4 81.5	30	15	7	11	14-1/2	57-1/8	60-5/8
JSE276S JSE276E	9	276	225	704	169	80.5 81.5	33-5/8	16-3/4	8	12-3/4	N.A.	59-7/8	N.A.
JSE310S JSE310E	10	310	245	767	184		37-1/8	18-5/8	8	14-1/2	N.A.	61-3/4	N.A.
JSE345S JSE345E	11	345	273	854	205		40-3/4	20-3/8	8	16-1/4	N.A.	63-1/2	N.A.
JSE379S JSE379E	12	379	299	933	224		44-1/4	22-1/8	8	18	N.A.	65-1/4	N.A.

* JSE 276 - JSE379 NOT AVAILABLE FOR USE WITH LP GAS

Suffix E = Intermittent Ignition, Suffix S = Standing Pilot. Add Suffix N for Natural Gas or Suffix L for Propane Gas to basic JSE model number (example: JSE207SN, JSE207SL)

III Before Installing

1) Safe, reliable operation of this boiler depends upon installation by a professional heating contractor in strict accordance with this manual and the requirements of the authority having jurisdiction.

- In the absence of an authority having jurisdiction, installation must be in accordance with this manual and the *National Fuel Gas Code*, ANSI Z223.1-latest edition.
- Where required by the authority having jurisdiction, this installation must conform to the *Standard for Controls and Safety Devices for Automatically Fired Boilers* (ANSI/ASME CSD-1)-latest edition.

2) Make sure that a properly sized chimney is available which is in good condition. Consult the authority having jurisdiction, Part VI of this manual, and the *National Fuel Gas Code* for additional information on venting requirements.

JSE boilers are equipped with an external draft hood which must be installed without alteration. Make sure that the adequate head room exist to install this JSE boiler with the unaltered hood and still maintain proper clearances from the vent connector to combustible materials.

3) Make sure that the boiler is correctly sized. Use an industry accepted sizing method such as the *I=B=R Installation Guide for Residential Hydronic Heating Systems* (Pub. #200) and *I=B=R Heat Loss Calculation Guide* (Pub. #H21 or #H22) published by the Hydronics Institute in Berkeley Heights NJ.

4) Make sure that the boiler received is configured for the correct gas (natural or LP). The JSE276, 310, 345, and 379 may only be used with natural gas.

5) Boilers built for installations at altitudes above 2000 ft. require different main burner orifice. Make sure that the boiler is configured for use at the correct altitude.

IV Locating the Boiler

1) Clearances:

- Observe the minimum clearances shown below. These clearances apply to all combustible construction, as well as noncombustible walls, ceilings and doors. Also see Figure 2.

<u>JSI</u>	<u>JSE</u>
Front – 18”	Front – 18”
Left Side – 18”	Left Side – 18”
Right Side – 6”	Right Side – 6”
Rear – 6”	Rear – 6”
Top – 17”	Top (JSE207, JSE241) - 35”
	Top (JSE276, JSE310) - 42”
	Top (JSE345, JSE379) - 47”

- A 24” service clearance from the jacket is recommended on the left, right, and front of the boiler. These clearances may be reduced to those shown in Figure 2, however servicing the boiler will become increasingly difficult as these service clearances are reduced.
- If the left side 24” service clearance is reduced, adequate clearance must be maintained to easily read and access the controls. Alternatively, access may be provided using a door

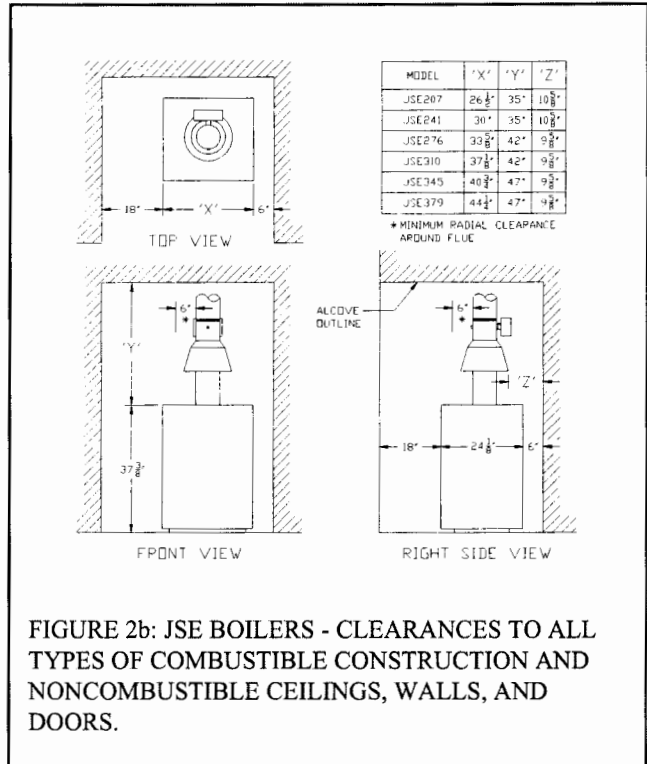
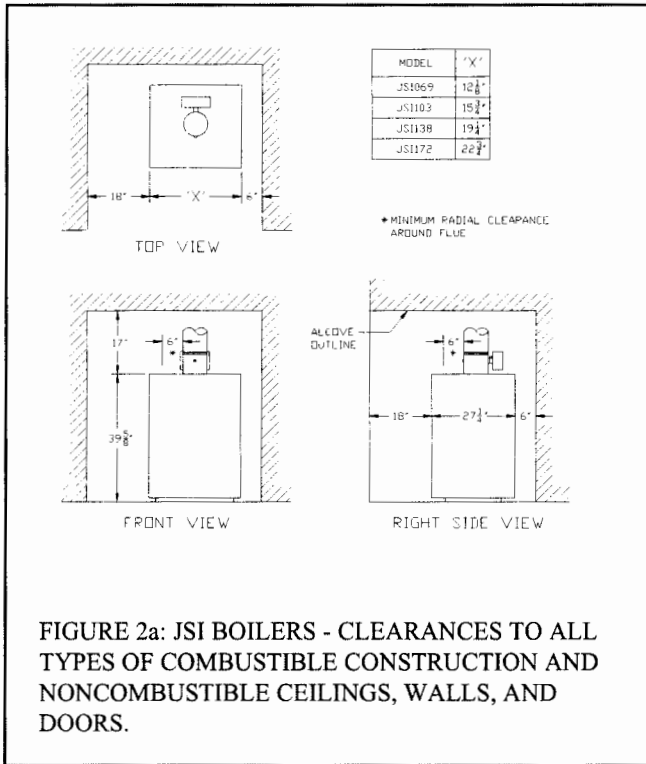

2) Do not install this boiler directly on a combustible floor. This boiler may be installed over a non-carpeted combustible floor is by using the following special bases available from Crown:

<u>Boiler Model</u>	<u>Combustible Base #</u>
JSI061 - JSI138	700100
JSI172, JSE207, JSE241	700101
JSE276 - JSE379	700102

A concrete or cinderblock pad will not protect combustible flooring. Under no circumstances may this boiler be installed over carpeting.

- 3) The boiler must be installed on a hard level surface.
- 4) Do not install this boiler in a location where gasoline or other flammable vapors or liquids will be stored or used. Do not install this boiler in an area where large amounts of airborne dust will be present, such as a workshop.
- 5) The boiler should be located as to the chimney as possible. Locate JSE boilers in an area which will permit the installation of the external draft hood supplied by Crown without alteration.
- 6) Do not install this boiler directly on a surface that may get wet. Raise the boiler on a pad.

V Air for Combustion and Ventilation

Sufficient fresh air must be supplied for combustion, ventilation and flue gas dilution. Provisions for combustion, ventilation and flue gas dilution air for gas utilization equipment vented by natural draft must be made in accordance with local building codes or, in absence of such codes, in accordance with sections 5.3.3 and 5.3.4 ("Air for Combustion and Ventilation") of the *National Fuel Gas Code*, NFPA 54/ANSI Z223.1.

To ensure an adequate supply of combustion, ventilation and flue gas dilution air supply, start by determining whether the boiler is to be installed in a building of unusually tight construction. A building of unusually tight construction is defined by the *National Fuel Gas Code* as having all of the following features:

- Walls and ceilings exposed to outside atmosphere have a continuous water vapor retarder with a rating of 1 perm or less with openings gasketed and sealed
- Weather stripping has been added on openable windows and doors
- Caulking and sealants are applied to areas such as joints around window and door frames, between sole plates and floors, between wall-ceiling joints, between wall panels, at penetrations for plumbing, electrical, and gas lines, and at other openings.

For Buildings of Other than Unusually Tight Construction

1) Determine whether the boiler is to be installed in a confined space - A confined space is defined by the *National Fuel Gas Code* as having a volume less than 50 cubic feet per 1000 BTU/hr input of all appliances installed in that space. To determine whether the boiler room is a confined space:

- a. Total the input of all appliances in the boiler room in thousands of BTU/hr. Round the result to the next highest 1000 BTU/hr.
- b. Find the volume of the room in cubic feet. The volume of the room in cubic feet is:
Length (ft) x width (ft) x ceiling height (ft)
In calculating the volume of the boiler room, consider the volume of adjoining spaces only if no doors are installed between them. If doors are installed between the boiler room and an adjoining space, do not consider the volume of the adjoining space, even if the door is normally left open.
- c. Divide the volume of the boiler room by the input in thousands of BTU/hr. If the result is less than 50, the boiler room is a confined space.

Example:

An JS1172EN and a water heater are to be installed in a room measuring 6 ft - 3 in x 7 ft with an 8 ft ceiling. The water heater has an input of 30000 BTU/hr:

Total input in thousands of BTU/hr = (172000 BTU/hr + 30000 BTU/hr)/1000 = 202

Volume of room = 6.25 ft x 7 ft x 8 ft = 350 ft³

350/202 = 1.73. Since 1.73 is less than 50, the boiler room is a confined space.

2) Unconfined Space - Natural infiltration into the boiler room will normally provide adequate air for combustion and ventilation without additional louvers or openings into boiler room.

3) Confined Space - Provide two openings into the boiler room, one near the floor and one near the ceiling. The top edge of the upper opening must be within 12" of the ceiling and the bottom edge of the lower opening must be within 12" of the floor (Figure 3).

- Each opening must have a free area of 1 square inch per 1000 BTU/hr input of all gas burning appliances in the boiler room. The minimum opening dimension is 3 inches. Minimum opening free area is 100 square inches per opening.
- If the total volume of both the boiler room and the room to which the openings connect is less than 50 cubic feet per 1000 BTU/hr of total appliance input, install a pair of identical openings into a third room. Connect additional rooms with openings until the total volume of all rooms is at least 50 cubic feet per 1000 BTU/hr of input.
- The "free area" of an opening takes into account the blocking effect of mesh, grills, and louvers. Where screens are used, they must be no finer than ¼" (4 x 4) mesh.
- If providing openings into adjacent rooms is undesirable, combustion and ventilation air can be brought into the boiler room from outdoors. See the instructions under "For Buildings of Unusually Tight Construction".

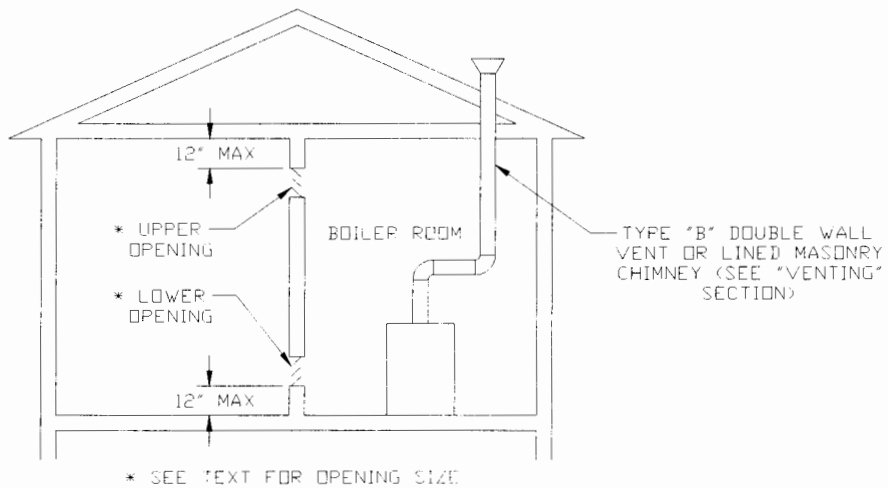

**FIGURE 3: BOILER INSTALLED IN CONFINED SPACE,
ALL AIR FROM INSIDE**

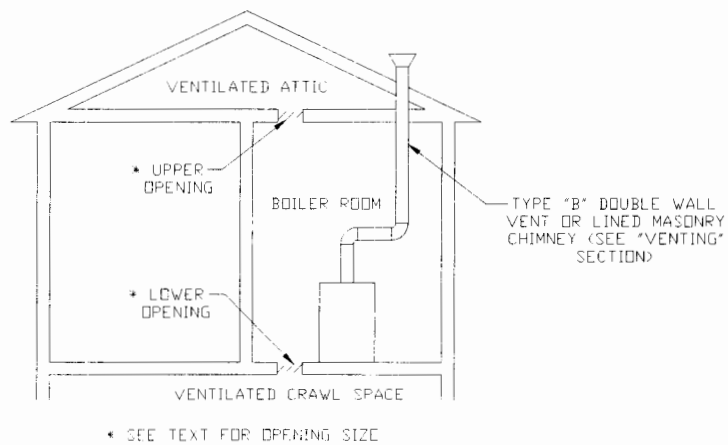

**FIGURE 4: ALL AIR FROM OUTDOORS,
VENTILATED CRAWL SPACE AND ATTIC**

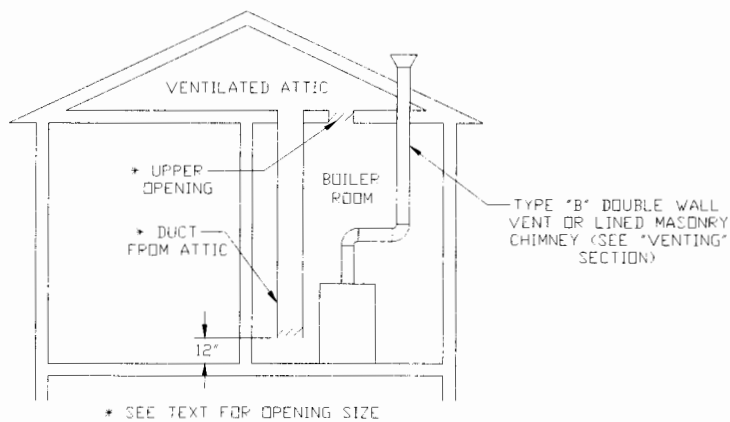

**FIGURE 5: ALL AIR FROM OUTDOORS,
VIA VENTILATED ATTIC**

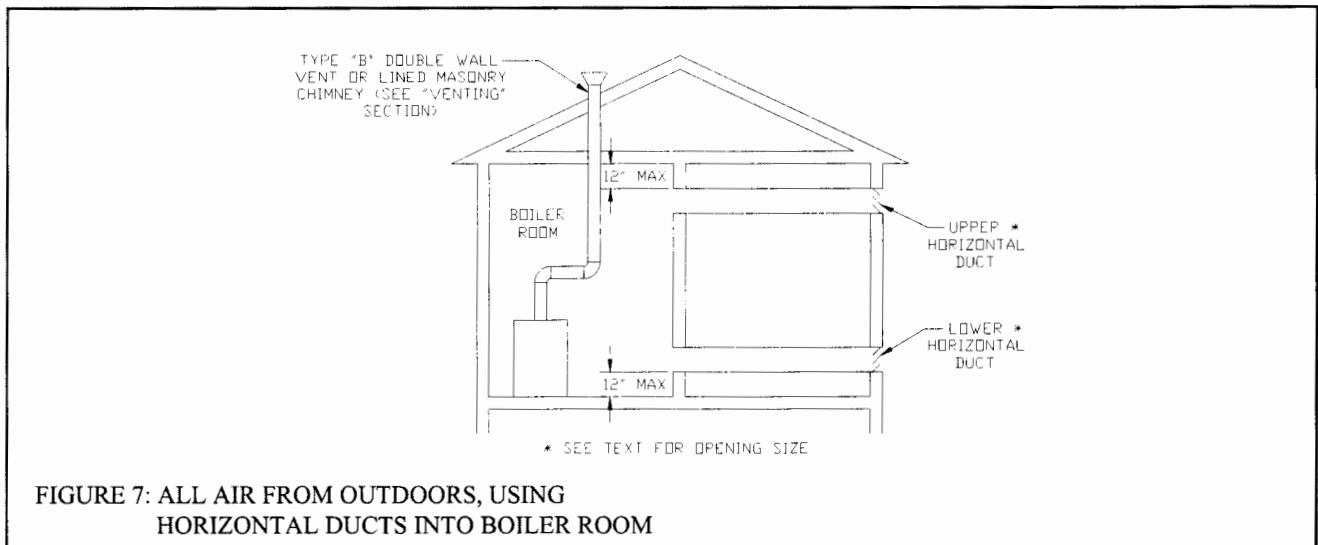
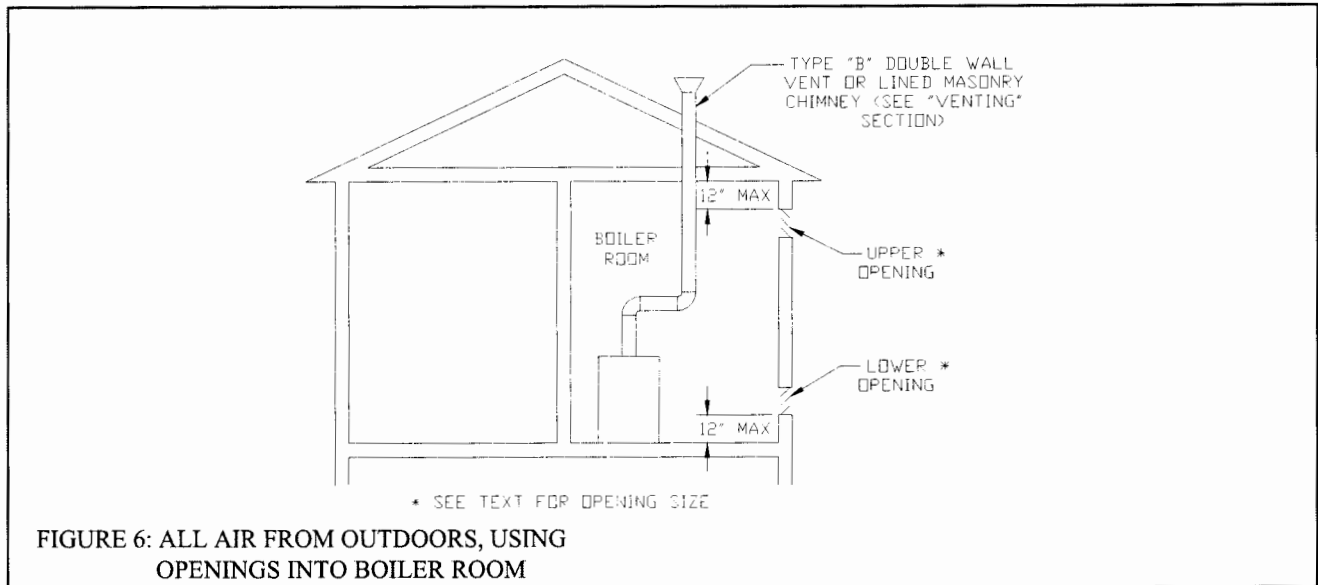

For Buildings of Unusually Tight Construction

- 1) Openings must be installed between the boiler room and the outdoors or a ventilated space, such as an attic or crawl space, which communicates directly with the outdoors.
- 2) Two openings are required. The top edge of the upper opening must be within 12 inches of the ceiling. The bottom edge of the lower opening must be within 12 inches of the floor.
- 3) Size openings and ducts as follows:
 - Vertical ducts or openings directly outdoors (Figure 4, Figure 5, and Figure 6) - Each opening must have a free cross sectional area of 1 square inch per 4000 BTU/hr of the total input of all gas-fired appliances in the boiler room but not less than 100 square inches. Minimum opening size is 3 inches.
 - Openings to outdoors via horizontal ducts (Figure 7) - Each opening must have a free cross sectional area of 1 square inch per 2000 BTU/hr of the total input of all gas fired appliances in the boiler room but not less than 100 square inches. Minimum opening size is 3 inches.
 - The "free area" of an opening takes into account the blocking effect of mesh, grills, and louvers. Where screens are used, they must be no finer than 1/4" (4 x 4) mesh.

VI Venting

Vent installation must be in accordance with local building codes, or the local authority having jurisdiction, or Parts 7 and 11 of the *National Fuel Gas Code*, NFPA 54/ANSI Z 223.1.

Typical vent installation is illustrated by Figure 8a and 8b for the JSI and JSE respectively. The components of vent installation are boiler draft diverter, vent damper, vent connector and chimney. The JSI is equipped with a draft diverter which is built into the boiler. The JSE is shipped with an external draft hood.

- 1) Acceptable Chimneys - The following chimneys may be used to vent JSI or JSE series boilers:
 - Listed Type B or L gas vent - Install in accordance with the manufacturer's instructions, the terms of its listing, and applicable codes.
 - Masonry Chimney - The masonry chimney must be constructed in accordance with the *Standard for Chimneys, Fireplaces, Vents, and Solid Fuel Burning Appliances* (NFPA 211) and lined with a clay liner or other listed lining system. Do not vent a JSI or JSE series boiler into an unlined chimney.
- 2) Acceptable Vent Connectors - The following may be used for vent connectors:
 - Listed type B or L Gas Vent
 - Single Wall Galvanized Pipe - Use 0.018" (26 gauge or heavier). The size and location of the chimney may not permit the use of a single wall connector in some cases. See Part 11 of the *National Fuel Gas Code*. Do not use single wall pipe for vent connectors in attics.
 - Other Vent Connectors Permitted by the *National Fuel Gas Code*.
- 3) Chimney and Vent Connector Sizing - Size the chimney and vent connector in accordance with Part 11 of the *National Fuel Gas Code*.
- 4) Exterior Chimneys - An exterior chimney has one or more sides exposed to the outdoors below the roof line. There are two conditions under which an exterior chimney may be used:
 - In some very restrictive cases, the JSI and JSE series boilers may be vented into an exterior ceramic lined masonry chimney. See Part 11.2.9 or 11.3.18 of the *National Fuel Gas Code* for information on when exterior chimneys may be used.
 - An exterior masonry chimney may be used if it is lined with B vent or a listed chimney lining system.
- 5) This boiler may vented using a listed power venter. The power venter must be in sized and installed in accordance with the power venter manufacturer's instructions, the terms of the power venter listing, and applicable codes. The boiler must be electrically interlocked with the power venter to prevent boiler operation if the power venter fails to operate. Before deciding to use a power venter, make certain that the flue gas exiting the power venter will not damage adjacent construction or other structures. Also make certain that the power venter terminal will not be subjected to winds which could effect power venter operation.
- 6) Do not connect the vent of this appliance into any portion of a mechanical vent system operating under positive pressure.
- 7) Do not connect the boiler into a chimney flue serving an open fireplace or other solid fuel appliance.
- 8) Prior to boiler installation, inspect chimney for obstructions or other defects and correct as required. Clean chimney as necessary.
- 9) JSE boilers are supplied with an external draft hood which must be installed without alteration as shown in Figure 8b. This hood is shipped in a carton inside the boiler crate. In some cases, the height of this hood depends upon whether the boiler is to be used with natural or propane gas. Before installing the draft hood, verify that the model number and fuel type marked on the draft hood carton matches that of the boiler being installed. Verify that the distance from the top of the jacket to the bottom of the draft hood skirt matches dimension "D" in Figure 1. Secure the hood to the boiler with at least three screws.

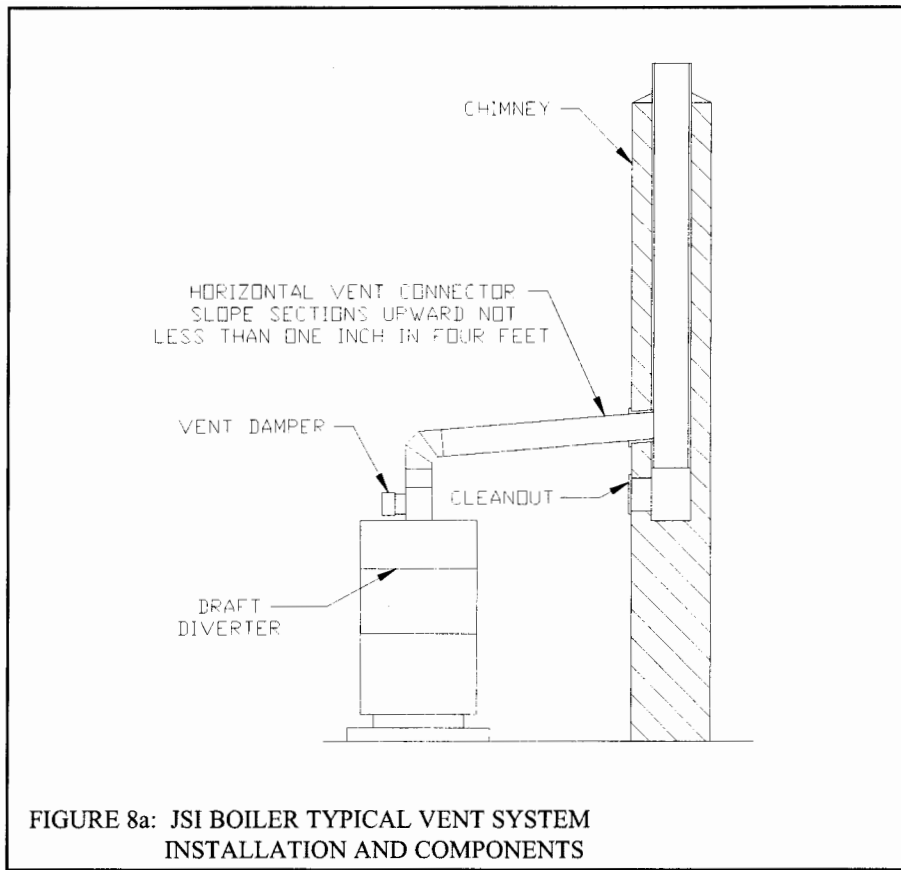

WARNING

Do not attempt to cut or otherwise alter the drafthood supplied with the JSE boiler. Do not mount the drafthood in a position other than that shown in Figure 8b. Doing either of these things could create a Carbon Monoxide hazard

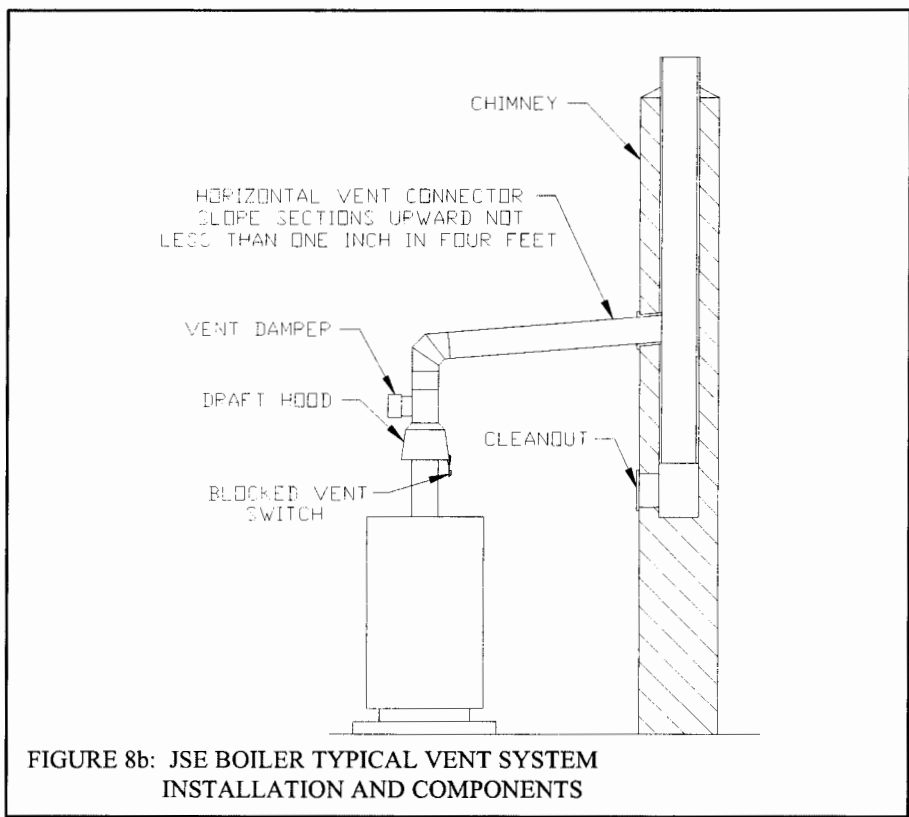

10) Install blocked vent switch assembly on JSE boiler models equipped with external draft hood (see Figure 9). The assembly consists of power cord and switch attached to mounting bracket and is shipped taped to the top of boiler jacket on JSE models. The procedure is outlined below:

- a) Untape Blocked Vent Switch Assembly from top of boiler. Uncoil power cord.
- b) Position mounting bracket onto lower edge of Draft Hood skirt. Locate center tooth (with #10 sheet metal screw) on outside and other two teeth inside Draft Hood skirt. See Figure 9.
- c) Slide mounting bracket tight against lower edge of Draft Hood skirt. Position #10 sheet metal screw above skirt's stiffening rib.
- d) Secure bracket in position by tightening #10 sheet metal screw against outer surface of Draft Hood skirt.
- e) Make sure that there is no slack in the power cord between the cable clamp on the junction box and the blocked vent switch on the draft hood.
- f) Verify power cord, mounting bracket and Blocked Vent Switch are secure and located as shown in Figure 9.

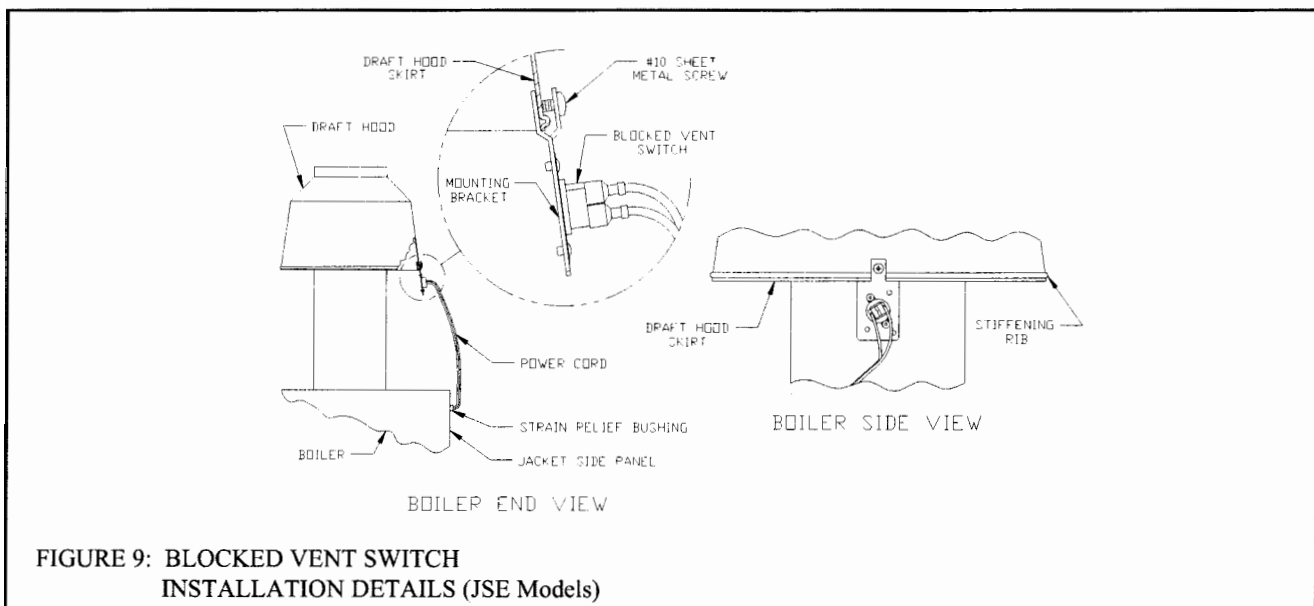

FIGURE 9: BLOCKED VENT SWITCH
INSTALLATION DETAILS (JSE Models)

- 11) JSI boiler models equipped with built-in draft diverter have blocked vent switch assembly factory installed.
- 12) Vent pipe should slope upward from draft diverter not less than one inch in four feet. No portion of vent pipe should run downward or have sags. Vent pipe must be securely supported.
- 13) The vertical section of vent pipe coming off the boiler should be as tall as possible, while still maintaining the proper clearance from the horizontal vent connector to combustibles and the proper pitch called for in (9) above.
- 14) Vent pipe should be installed above the bottom of the chimney to prevent blockage.
- 15) Vent pipe must be inserted flush with inside face of the chimney liner and the space between vent pipe and chimney sealed tight.
- 16) Do not install the vent damper in any portion of the vent system which is used by appliances other the boiler being installed.

- 17) Vent damper installation is mandatory on all JSI and JSE/ boiler models. Install vent damper (see Figure 9) as follows:
- Open vent damper carton and remove installation instructions. Read the instructions thoroughly before proceeding. Verify that vent damper is same size as draft diverter outlet. See Figure 1. Unpack vent damper carefully. **Do not force closed damper blade.** Forcing vent damper closed may result in damaged gear train and void warranty.
 - Vent damper is factory shipped having approximately ¼" diameter hole in the vent damper blade, which **must be left open** for boilers equipped with standing pilot, and should be plugged on boilers with EI control system, using the plug supplied with the damper.
Mount the vent damper on the flue collar without modification to either and secure with sheet metal screws. Make sure screws do not interfere with damper blade operation. Vent damper blade position indicator must be visible to users.
 - The damper wire harness is shipped wired into the boiler junction box. Plug the loose end of this harness into the damper and secure the flexible conduit to the damper using a connector nut provided. Provide adequate clearance to combustible construction and servicing.
 - Install vent connector pipe and vent fittings from vent damper outlet to chimney or gas vent. Secure with sheet metal screws and support as required.

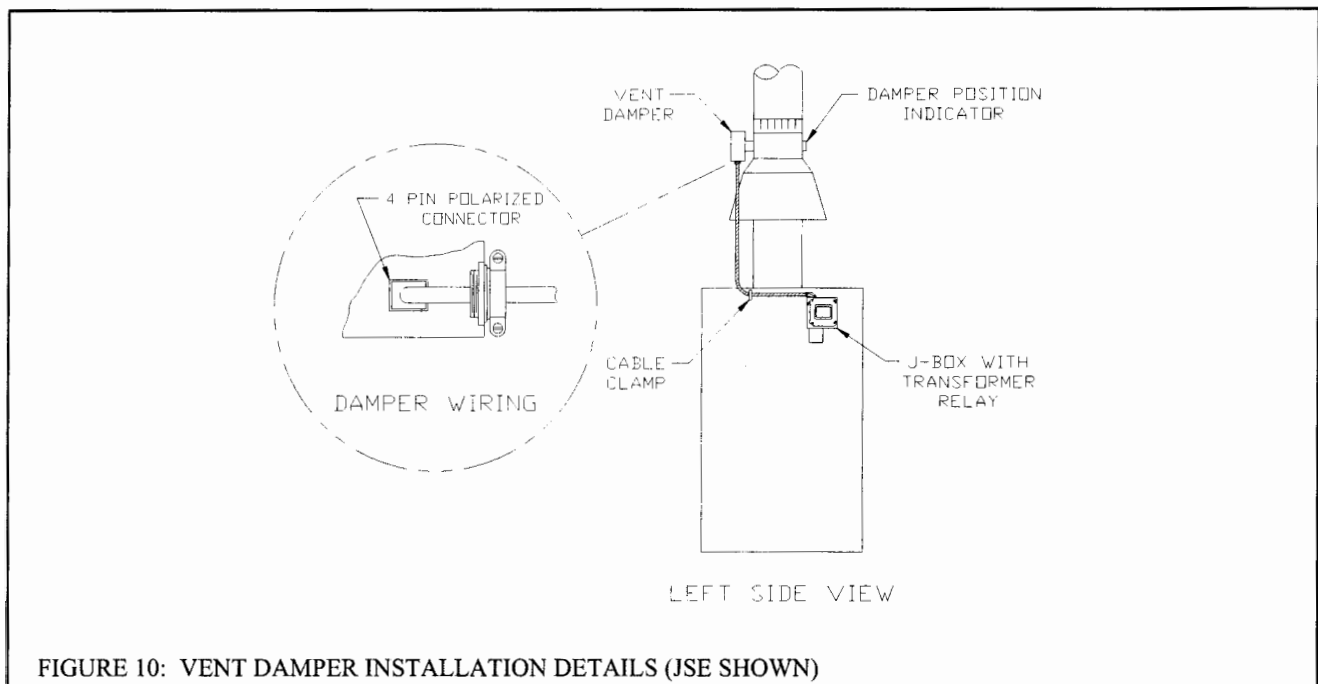

FIGURE 10: VENT DAMPER INSTALLATION DETAILS (JSE SHOWN)

Removing an Existing Boiler from a Common Chimney

In some cases, when an existing boiler is removed from a common chimney, the common venting system may be too large for the remaining appliances. At the time of removal of an existing boiler the following steps shall be followed with each appliance remaining connected to the common venting system placed in operation, while the other appliances remaining connected to the common venting system are not in operation.

- Seal any unused opening in the common venting system.
- Visually inspect the venting system for proper size and horizontal pitch and determine there is no blockage or restriction, leakage, corrosion and other deficiencies which could cause an unsafe condition.
- Insofar as practical, close all building doors and windows and all doors between the space in which all the appliances remaining connected to the common venting system are located and other spaces of the building. Turn on clothes dryers and any appliance not connected to the common venting system. Turn on any exhaust fans, such as range hoods and bathroom exhausts, so they will operate at maximum speed. Do not operate a summer exhaust fan. Close fireplace dampers.

- d) Place in operation the appliance being inspected. Follow the lighting instructions. Adjust thermostat so the appliance will operate continuously.
- e) Test for spillage at the draft hood relief opening after five (5) minutes of main burner operation. Use the flame of a match or candle, or smoke from a cigarette, cigar, or pipe.
- f) After it has been determined that each appliance remaining connected to the common venting system properly vents when tested as outlined above, return doors, windows, exhaust fans, fireplace dampers and any other gas-burning appliances to their previous condition of use.
- g) Any improper operation of the common venting system should be corrected so the installation conforms with the National Fuel Gas Code, ANSI Z223.1. When resizing any portion of the common venting system, the common venting system should be resized to approach the minimum size as determined using the appropriate tables in Part 11 of the National Fuel Gas Code, ANSI Z223.1.

VII Gas Piping

Gas piping to the boiler must be sized to deliver adequate gas for the boiler to fire at the nameplate input at a line pressure between the minimum and maximum values shown on the rating plate. For more information on gas line sizing, consult the utility or Part 2 of the *National Fuel Gas Code*.

Figure 10 shows typical gas piping connection to the JSI/JSE boiler. A sediment trap must be installed upstream of all gas controls. Install a manual shut-off valve outside the jacket and ground joint union as shown.

The boiler and its gas connection must be leak tested before placing the boiler in operation. When doing this, the boiler and its individual shut-off must be disconnected from the rest of the system during any pressure testing of that system at pressures in excess of 1/2 psi. When pressure testing the gas system at pressures of 1/2 psi or less, isolate the boiler from the gas supply system by closing its individual manual shut-off valve.

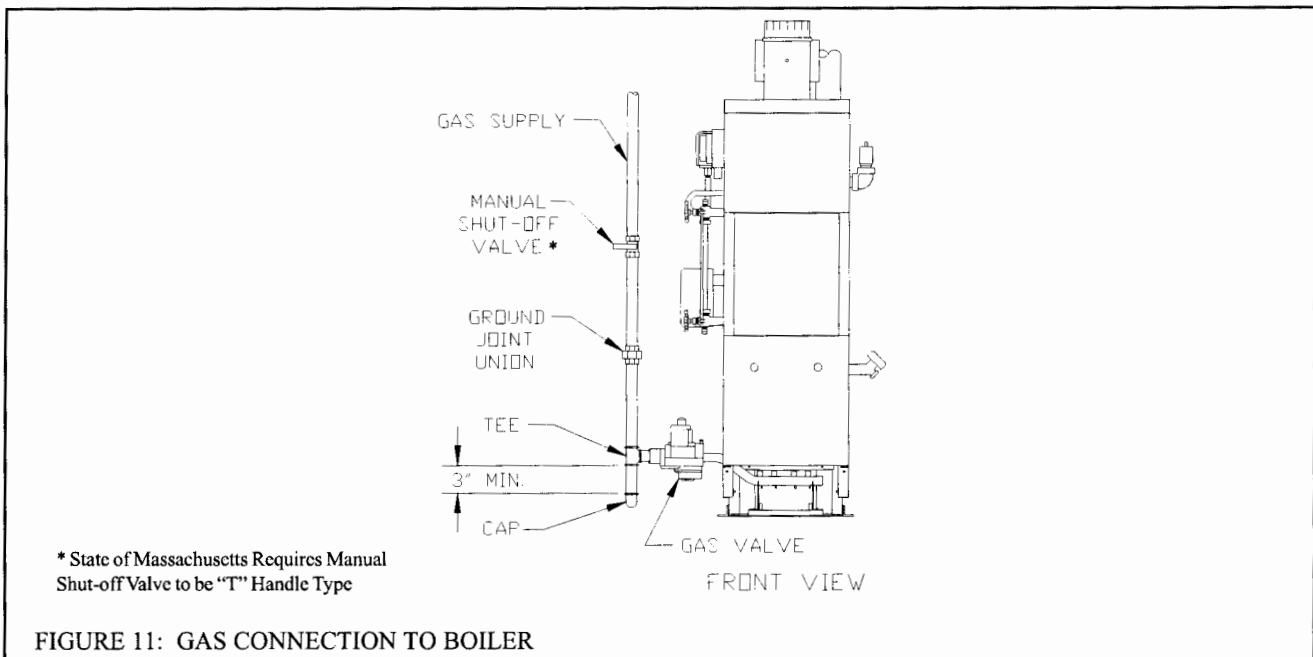

VIII System Piping

CAUTION

- INSTALL BOILER SO THAT THE GAS IGNITION SYSTEM COMPONENTS ARE PROTECTED FROM WATER (DRIPPING, SPRAYING, RAIN, ETC.) DURING APPLIANCE OPERATION AND SERVICE (CIRCULATOR REPLACEMENT, ETC.).
- OPERATION OF THIS BOILER IN A SYSTEM HAVING SIGNIFICANT AMOUNTS OF DISSOLVED OXYGEN CAN CAUSE SEVERE HEAT EXCHANGER CORROSION DAMAGE.

General Piping Notes

Figure 12 shows recommended near boiler Piping for most common types of gravity return steam systems. Additional information on steam system design may be found in *Installation Guide for Residential Hydronic Heating Systems* (Pub. #200) published by the Hydronics Institute in Berkeley Heights NJ.

One of the primary purposes of this near boiler piping is to separate tiny water droplets from the steam exiting the boiler so that "dry" steam is sent to the system. If the near boiler piping is not correct, wet steam will enter the system and the following problems may occur:

- Short cycling on low water
- Boiler or system Flooding
- Hammering
- Failure to heat one or more radiators

Avoid the three common piping mistakes shown in Figure 13. This applies even if the existing boiler has one of the piping mistakes shown in Figure 13 and appears to be working. If two or more steam mains must be connected to the boiler, connect a separate take-off for each main into the header between the riser/s and equalizer. Also note the following points:

- 1) A size reduction must be made to connect the header to the equalizer. This reduction must be made in the equalizer line. Do not make this size reduction in the horizontal header.
- 2) One pipe steam systems require air vents on each radiator, as well as at the end of each main. For the system to work properly, these vents must be properly installed, sized, and be in good condition. Inspect and replace any defective vents. If there are no vents at the ends of the mains, install them.
- 3) Do not attempt to manifold multiple JSIs or JSEs with gravity returns.
- 4) Do not attempt to pipe an indirect water heater into a JSI or JSE below the waterline.
- 5) For installations with condensate or boiler feed pumps, follow the pump manufacturer's piping instructions. Such systems generally do not require Hartford loops.
- 6) Do not use a check valve in place of, or in addition to, a Hartford loop on a gravity return system.
- 7) Pipe the fill connection from a clean source of cold water. When the water supply is from a well, make sure that a strainer is installed in the well system.
- 8) Piping with a Chiller - If the boiler is used in conjunction with a chiller, pipe the boiler in parallel with chiller. Use isolation valves to prevent chilled water from entering the boiler.

Piping Installation

- 1) Remove parts bag from boiler crate.
- 2) Install safety valve (spindle must be in vertical position) into tapping on boiler right side (see Figure 1A and 1B) using the 3/4" NPT nipples and elbow supplied.
- 3) Pipe the discharge of the safety relief valve to a location where water or steam will not create a hazard or cause property damage if the valve opens. The end of the discharge pipe must terminate in an unthreaded pipe. If the safety valve discharge is not piped to a drain it must terminate at least 6 inches above the floor. The termination of the safety valve discharge piping must be in an area where it is not likely to become plugged by debris or subjected to freezing.

DANGER

- PIPE SAFETY VALVE DISCHARGE TO A SAFE LOCATION.
- DO NOT INSTALL A VALVE IN THE SAFETY VALVE DISCHARGE LINE.
- DO NOT MOVE SAFETY VALVE FROM FACTORY LOCATION.
- DO NOT PLUG SAFETY VALVE DISCHARGE.
- DO NOT INSTALL A SAFETY VALVE WITH A SETTING GREATER THAN 15 PSI

- 4) Install drain valve into tapping on boiler right side using the 2 x 3/4 bushing provided. (see Figure 1A and 1B).
- 5) Connect system supply and return to boiler. See Figure 12. All JSI boiler models use one supply riser and one return tapping. All JSE boiler models use two supply risers and one return tapping with the exception of model JSE207 where use of second supply riser is optional.
- 6) Piping with a Chiller - If the boiler is used in conjunction with a chiller, pipe the boiler in parallel with chiller. Use isolation valves to prevent chilled water from entering the boiler.

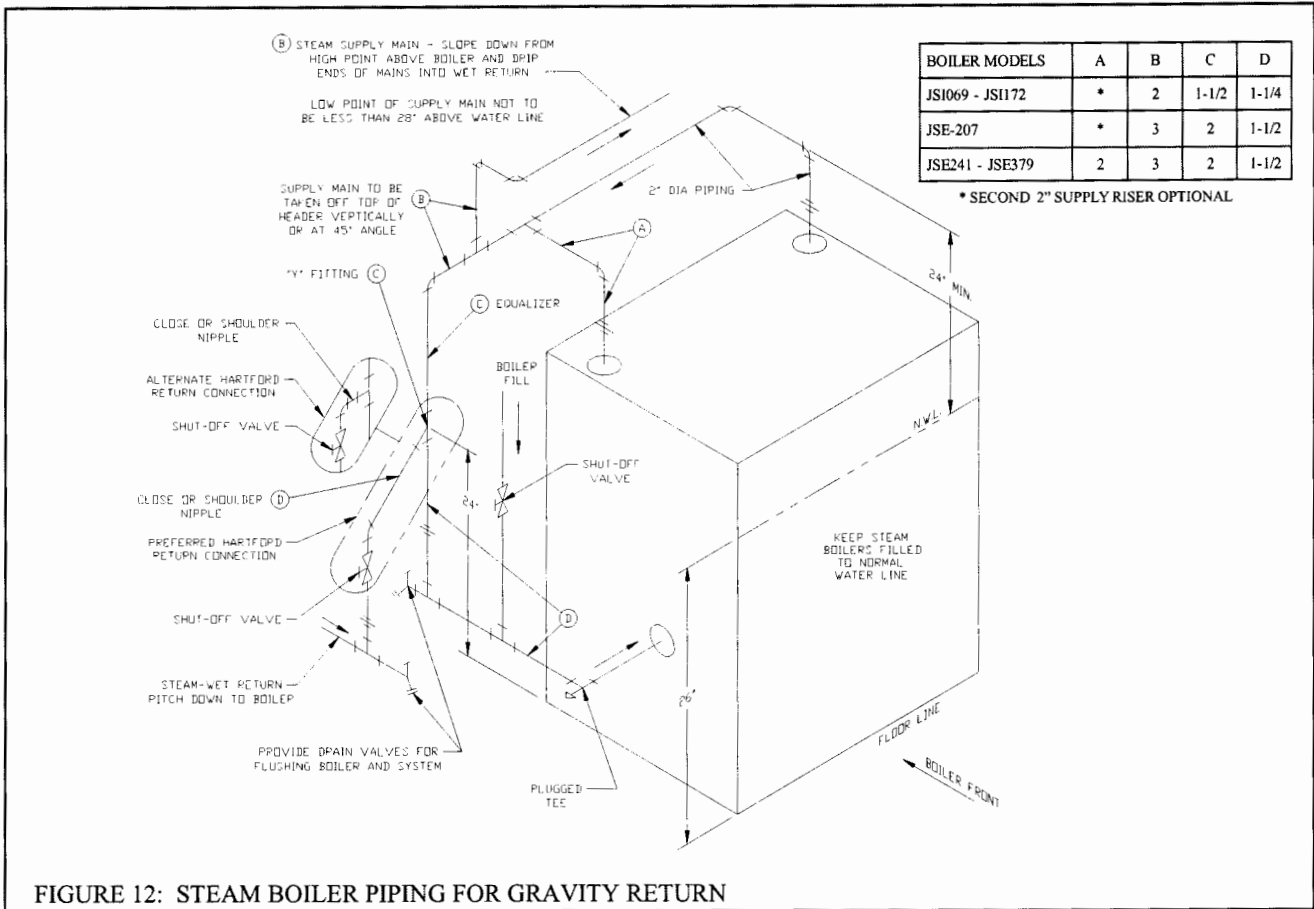

FIGURE 12: STEAM BOILER PIPING FOR GRAVITY RETURN

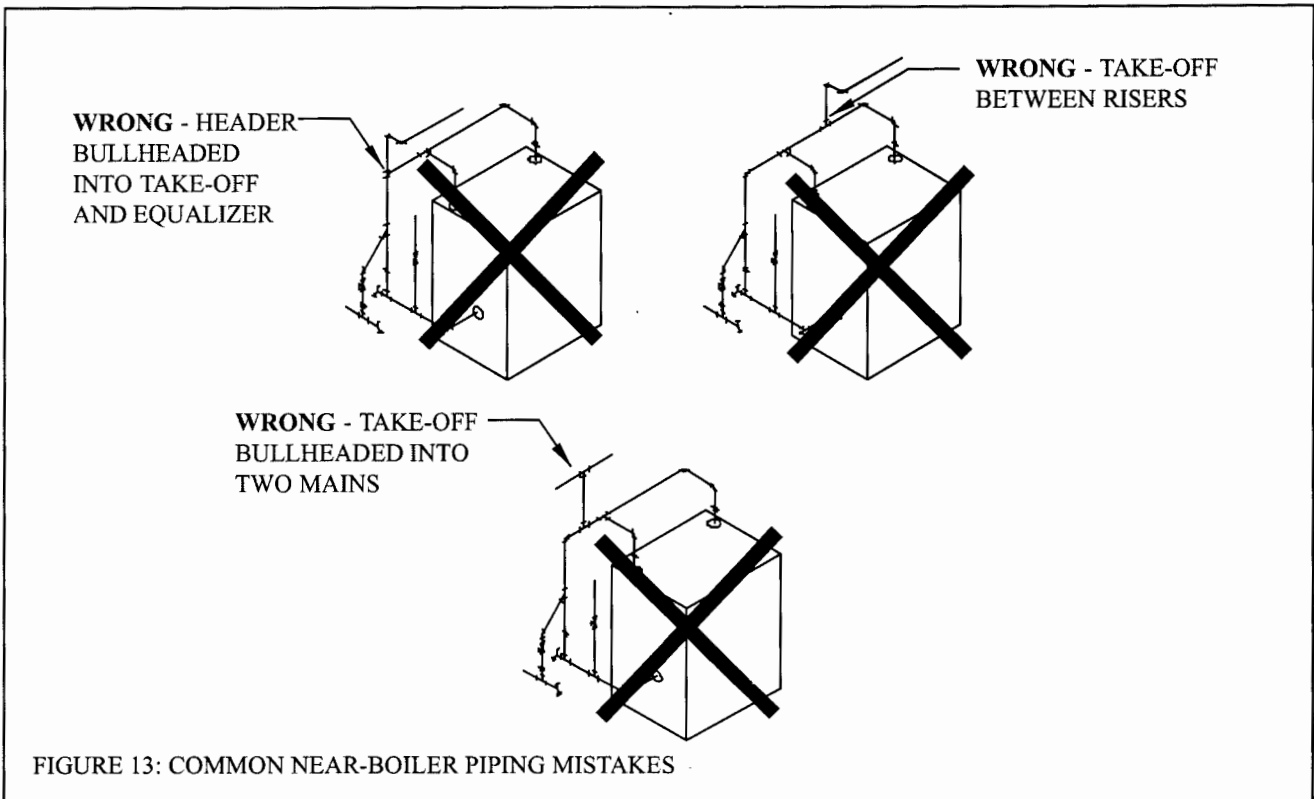

FIGURE 13: COMMON NEAR-BOILER PIPING MISTAKES

IX Wiring

WARNING

All wiring and grounding must be done in accordance with the authority having jurisdiction or, in the absence of such requirements, with the National Electrical Code (ANSI/NFPA 70)

- 1) 120 Volt Wiring - The boiler should be provided with its own 15A branch circuit with fused disconnect. All 120 volt connections are made inside the junction box on the left side of the boiler. Remove the transformer to gain access to this box (also see Figures 14 through 17):
 - Hot ("black") - Wire nut to black transformer lead
 - Neutral ("white") - Wire nut to white transformer lead
 - Ground ("green" or bare) - Ground screw inside junction box.

- 2) Thermostat Wiring - Follow thermostat manufacturer instructions. To insure proper thermostat operation, avoid installation in areas of poor air circulation, hot spots (near any heat source or in direct sunlight), cold spots (outside walls, walls adjacent to unheated areas, locations subject to drafts). Provide Class II circuit between thermostat and boiler. Connect thermostat wire leads to the blue transformer lead and brown relay lead inside the junction box. Set the heat anticipator to 0.2A.

Feeder Wiring for Boilers Equipped with Hydrolevel CG400A Low Water Cut-offs

CAUTION

Do not attempt to connect a McDonnell & Miller model #101A feeder, or other feeder without a delay, to a JSI or JSE equipped with a Hydrolevel CG400 low water cutoff. Doing so could destroy the boiler transformer and/or flood the system.

- 1) Using Hydrolevel VXT-24 feeder - Do not alter factory boiler wiring. Connect VXT-24 to CG400A as follows:
 - Connect the **BLACK** lead on the feeder to terminal **A** on the LWCO
 - Connect the **WHITE** lead on the feeder to terminal **2** on the LWCO

- 2) Using McDonnell & Miller WF2-U-24 feeder - Do not alter factory boiler wiring. Connect WF2-U-24 to CG400A as follows:
 - Connect terminal **1** on the feeder to terminal **A** on the LWCO
 - Connect terminal **2** on the feeder to terminal **2** on the LWCO
 - Connect terminal **3** on the feeder to terminal **1** on the LWCO

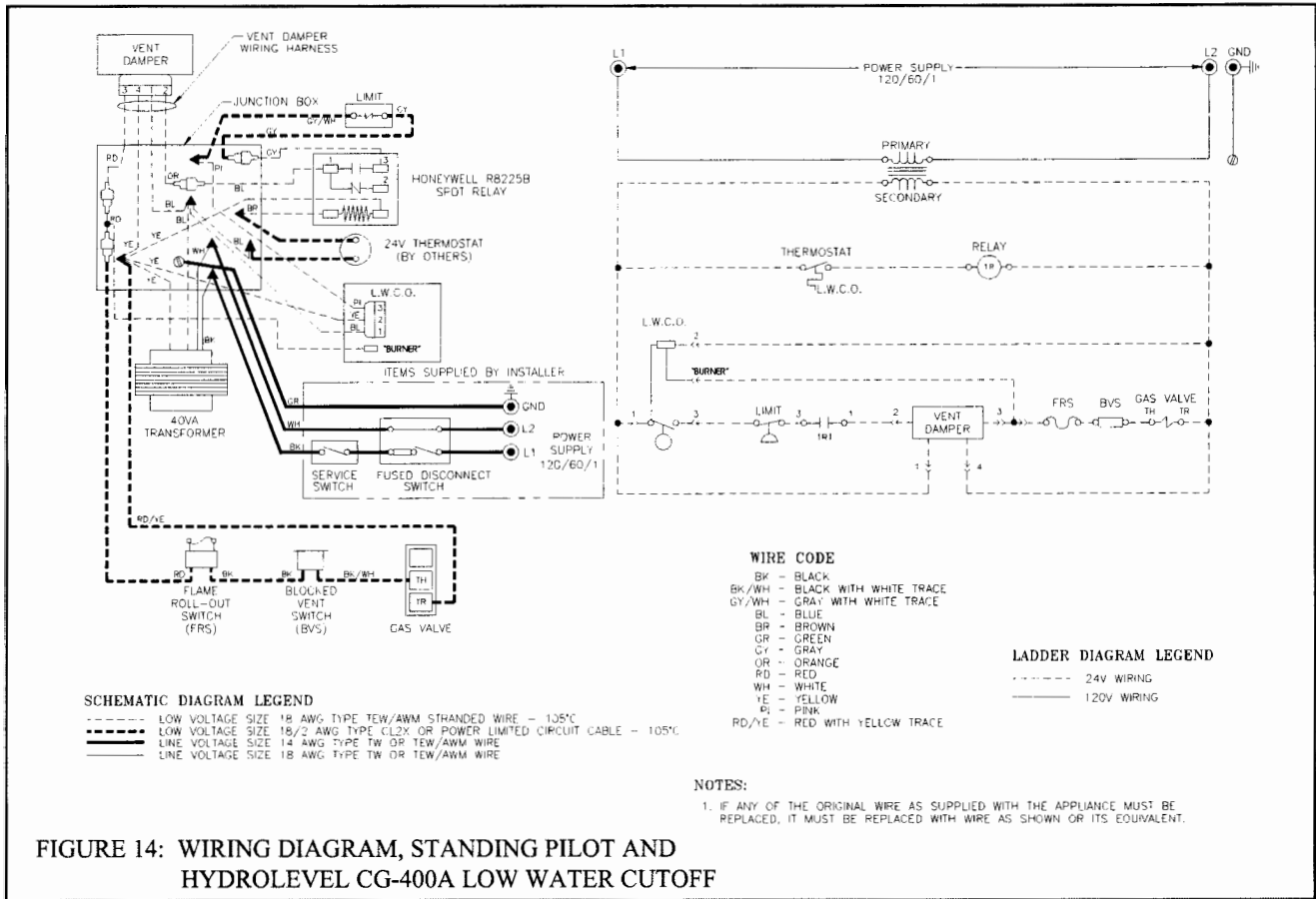

FIGURE 14: WIRING DIAGRAM, STANDING PILOT AND HYDROLEVEL CG-400A LOW WATER CUTOFF

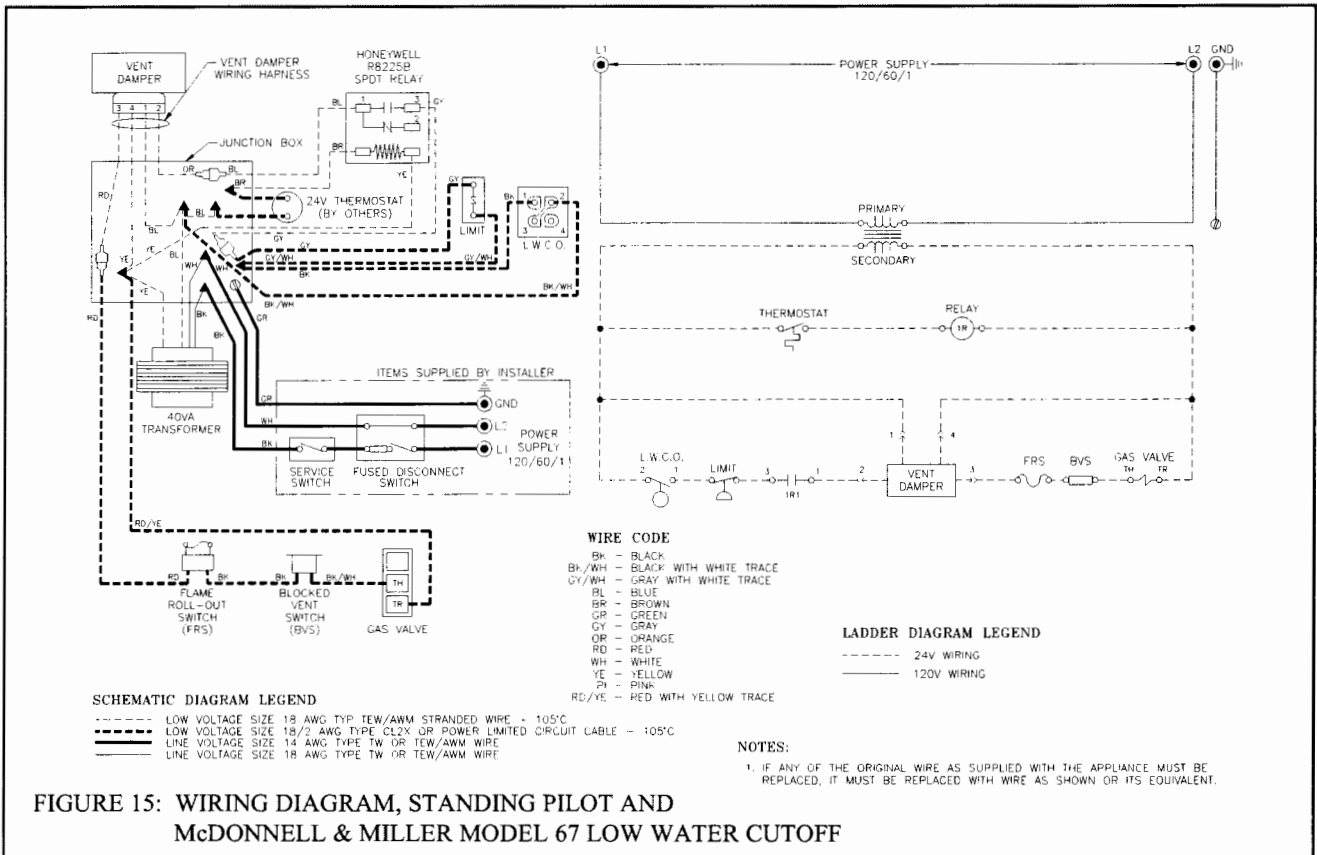

FIGURE 15: WIRING DIAGRAM, STANDING PILOT AND McDONNELL & MILLER MODEL 67 LOW WATER CUTOFF

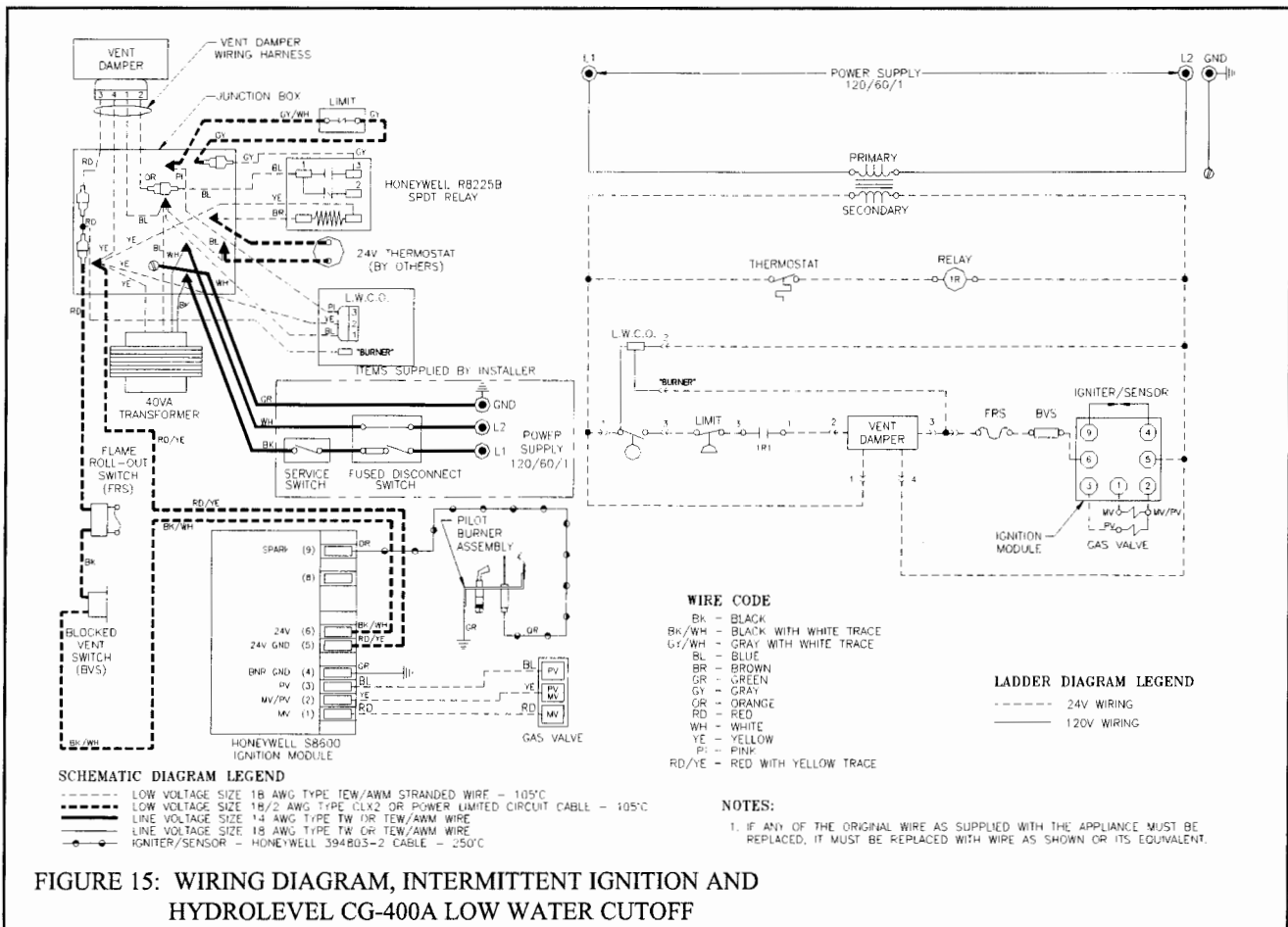

FIGURE 15: WIRING DIAGRAM, INTERMITTENT IGNITION AND HYDROLEVEL CG-400A LOW WATER CUTOFF

Feeder Wiring for Boilers Equipped with McDonnell & Miller Low Water Cut-offs

Figures 18a and 18b show feeder wiring for McDonnell & Miller #101A, McDonnell & Miller WF2-U-24 and Hydrolevel VXT-24 feeders on boilers equipped with #67 low water cut-offs. The following points apply to all feeder wiring to #67 low water cut-offs:

- Use a separate transformer to power the feeder. Do not use the transformer on the boiler.
- It is not necessary to touch any of the 24 volt factory boiler wiring when connecting a feeder to a #67 equipped boiler.
- Do NOT install a jumper between terminals 2 and 3 on the #67 low water cutoff.

JSI/JSE Control System – Sequence of Operation

(Refer to Figures 14 through 17 for ladder and connection diagrams)

Sequence of Operation, Standing Pilot

1) When the boiler is energized, 24 volts is immediately applied to terminals “1” (blue) and “4” (yellow) on the vent damper. Assuming that there is no call for heat, and that the damper switch is in the “automatic” position, the damper will close. On boilers equipped with Hydrolevel CG400A probe type low water cut-offs, voltage is also always applied to terminals “1” (blue) and “2” (yellow) on the low water cut-off to power the water level sensing circuit. On boilers equipped with #67 float type low water cut-offs, power is always applied to terminal “2” on the #67 LWCO.

- 2) Assuming that water is above the cut-off level, power will appear at terminal "3" on the CG400 LWCO or terminal "1" on the #67 LWCO.
- 3) Assuming that steam pressure is below the pressure limit setting, power will appear on one side of relay contact 1R1 (Gray lead). Relay 1R is the R8225 mounted under the junction box.
- 4) A call for heat from the thermostat energizes relay coil 1R causing contacts 1R1 to make. Current then flows through contacts 1R1 to pin terminal "2" (orange) at the vent damper and the damper opens.
- 5) Once the vent damper is fully open, an end switch inside the damper will make, energizing pin "3" (red) at the damper.
- 6) Current passes from terminal "3" on the vent damper through the flame rollout and blocked vent ("spill") switches. Under normal conditions, both of these switches are made and voltage will therefore immediately appear across the combination gas control ("gas valve") terminals "TH" and "TR".
- 7) When the boiler is first placed into operation, the pilot must be lit. The pilot heats a thermocouple which generates a small amount of electricity sufficient to hold open the safety shut-off valve in the combination gas control. The circuit connecting the thermocouple and the safety shut-off valve is self contained and completely independent of all other wiring on the boiler. This safety shut-off valve is upstream of the 24 volt valves in the gas control which open in response to a call for heat. If the pilot is not lit, the safety shut-off valve will remain closed and gas will not reach the 24 volt valves.
- 8) Assuming that the pilot is established and proven by the thermocouple, the application of 24 volts across the combination gas valve terminals energizes the redundant 24 volt solenoid valves in the combination gas control, resulting in gas flow through the control and burner operation.

Sequence of Operation, Intermittent Ignition

- 1) When the boiler is energized, 24 volts is immediately applied to terminals "1" (blue) and "4" (yellow) on the vent damper. Assuming that there is no call for heat, and that the damper switch is in the "automatic" position, the damper will close. On boilers equipped with Hydrolevel CG400A probe type low water cut-offs, voltage is also always applied to terminals "1" (blue) and "2" (yellow) on the low water cut-off to power the water level sensing circuit. On boilers equipped with #67 float type low water cut-offs, power is always applied to terminal "2" on the #67 LWCO.

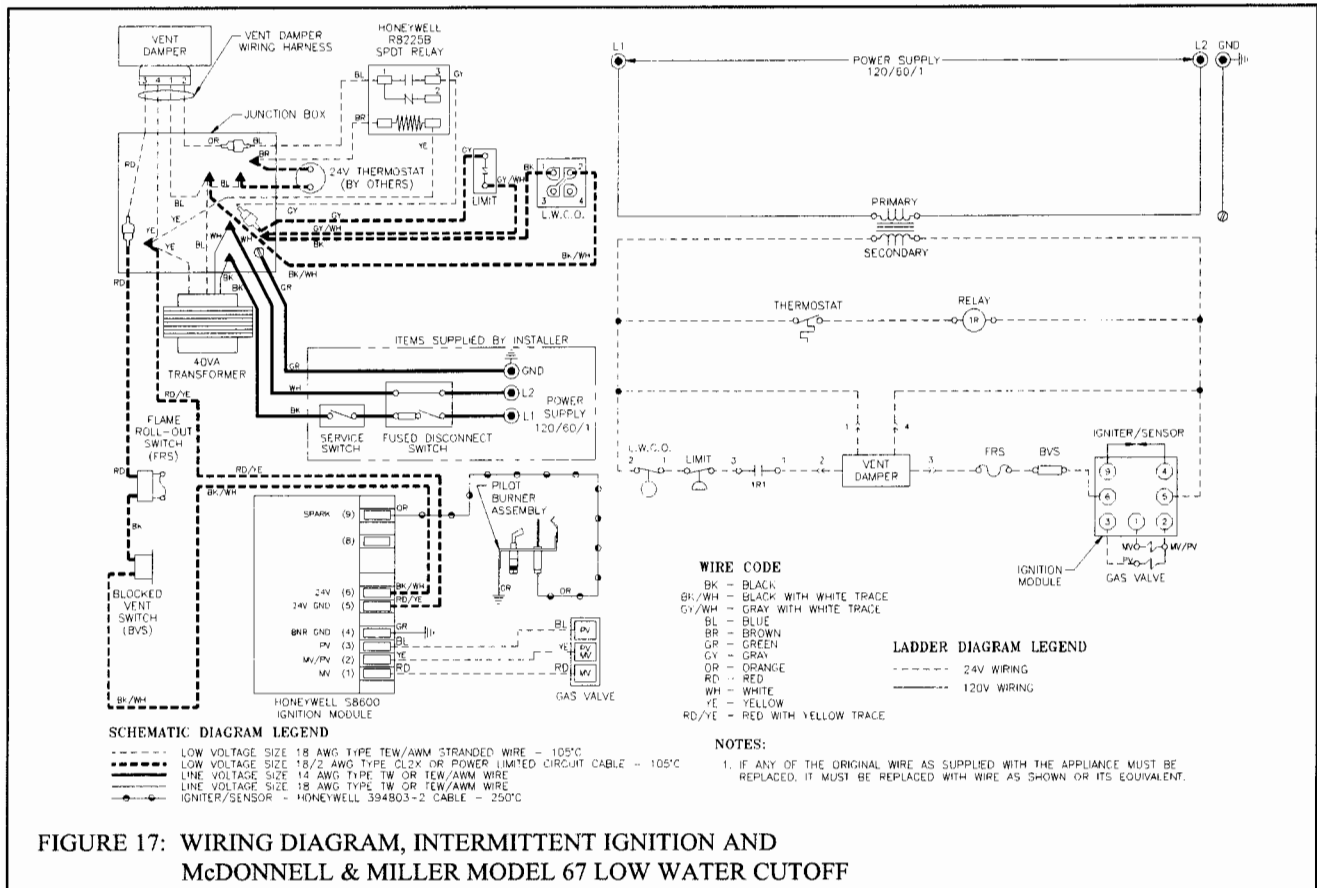

- 2) Assuming that water is above the cut-off level, power will appear at terminal "3" on the CG400 LWCO or terminal "1" on the #67 LWCO.
- 3) Assuming that steam pressure is below the pressure limit setting, power will appear on one side of relay contact 1R1 (Gray lead). Relay 1R is the R8225 mounted under the junction box.
- 4) A call for heat from the thermostat energizes relay coil 1R causing contacts 1R1 to make. Current then flows through contacts 1R1 to pin terminal "2" (orange) at the vent damper and the damper opens.
- 5) Once the vent damper is fully open, an end switch inside the damper will make, energizing pin "3" (red) at the damper.
- 6) Current passes from terminal "3" on the vent damper through the flame rollout and blocked vent ("spill") switches. Under normal conditions, both of these switches are made and voltage will therefore immediately appear across terminals "24V" and "24V (GND)" on the ignition module.
- 7) Upon application of voltage across the "24V" and "24V (GND)" terminals, the ignition module will start an ignition spark at the pilot and apply 24 volts across the pilot valve (terminals "PV" and "MV/PV").
- 8) Once the pilot is established, the pilot flame will act as a diode, converting the AC current at the electrode to a half wave DC current at the pilot's ground strap. This DC current flows through the boiler to the "GND (BURNER)" connection on the ignition module. For the ignition module to recognize that a pilot flame is present, the DC current flowing into this terminal must be in excess of approximately 1.0 uA.
- 9) Once the ignition module detects the presence of a pilot flame, voltage is applied across the main valve (terminals "MV" and "MV/PV"), opening the valve and establishing main flame.
- 10) The way in which the ignition module handles failure to establish pilot or the loss of an already established pilot depends upon the exact ignition module supplied with the boiler. For more information on module operation, consult the ignition module instructions supplied with the boiler or the local Crown representative.

Safety Control Operation - Standing Pilot and Intermittent Ignition

Hydrolevel CG400A Low Water Cut-off - Interrupts burner operation if the water in the boiler drops below a safe level. As the water drops past the cut-off point, the amber lamp on the CG400 will glow. The CG400 will interrupt power to the burners 15 seconds after the water level drops past the cut-off point. This feature prevents short cycling of the burners due to a bouncing water line. The burners will then remain off until 30 seconds after the water level has been raised above the cut-off point.

The CG400 is also equipped with a feature which will shut down the burners after they have been firing for 10 minutes, regardless of the water level status. The CG400 then keeps the burners off for 90 seconds, allowing the water level and any foam which is present to settle. During this 90 second interval, the green LED on the CG400 will glow. If the water level is still above the cut-off line at the end of this 90 second interval, the CG400 will restart the burners.

The vent damper will close when the low water cut-off interrupts burner operation.

McDonnell & Miller #67 Low Water Cut-off - Interrupts burner operation if the water in the boiler drops below a safe level. Burner operation is restored when the water level in the boiler is raised above the cut-off point.

The vent damper will close when the low water cut-off interrupts burner operation.

Pressure Limit Control - Interrupts burner operation when the pressure in the boiler exceeds the "Cut-in" setting plus the differential setting. The "Cut-in" setting is shown on the outside of the control and is adjusted using the screw on the top of the control. The differential is adjusted using the white thumb wheel on the inside of the control. Burner operation is restored when the pressure in the boiler drops to the "Cut-in" pressure.

The vent damper will close when the pressure limit control interrupts burner operation.

Blocked Vent ("Spill") Switch - Automatically interrupts burner operation in the event that flue gas spills from the draft diverter opening. This switch is equipped with a reset button which must be pressed to restore normal burner operation. An open blocked vent switch is indicative of a problem with the vent system. If the blocked vent switch opens, the cause of the venting problem must be found and corrected by a qualified gas service technician before the blocked vent switch is reset.

Flame Roll-out Switch - Automatically interrupts burner operation when flames or excessive heat are present in vestibule. The flame roll-out switch is a single use device which must be replaced by a identical switch in order to restore normal operation. An open flame roll-out switch is usually indicative of a plugged heat exchanger. The cause of the flame roll-out must be found and corrected by a qualified gas service technician, and the switch replaced with an identical one, before the boiler is returned to operation.

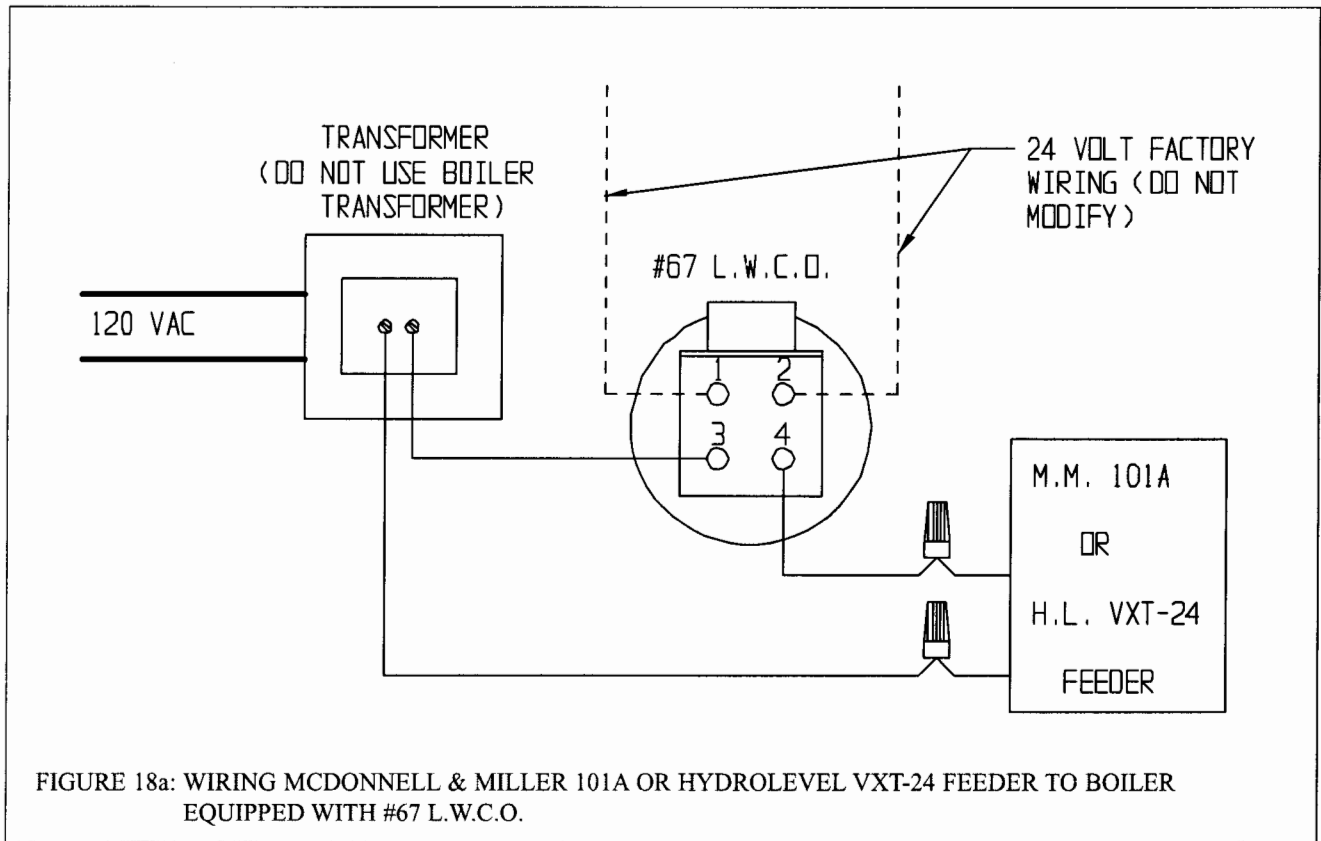

FIGURE 18a: WIRING MCDONNELL & MILLER 101A OR HYDROLEVEL VXT-24 FEEDER TO BOILER EQUIPPED WITH #67 L.W.C.O.

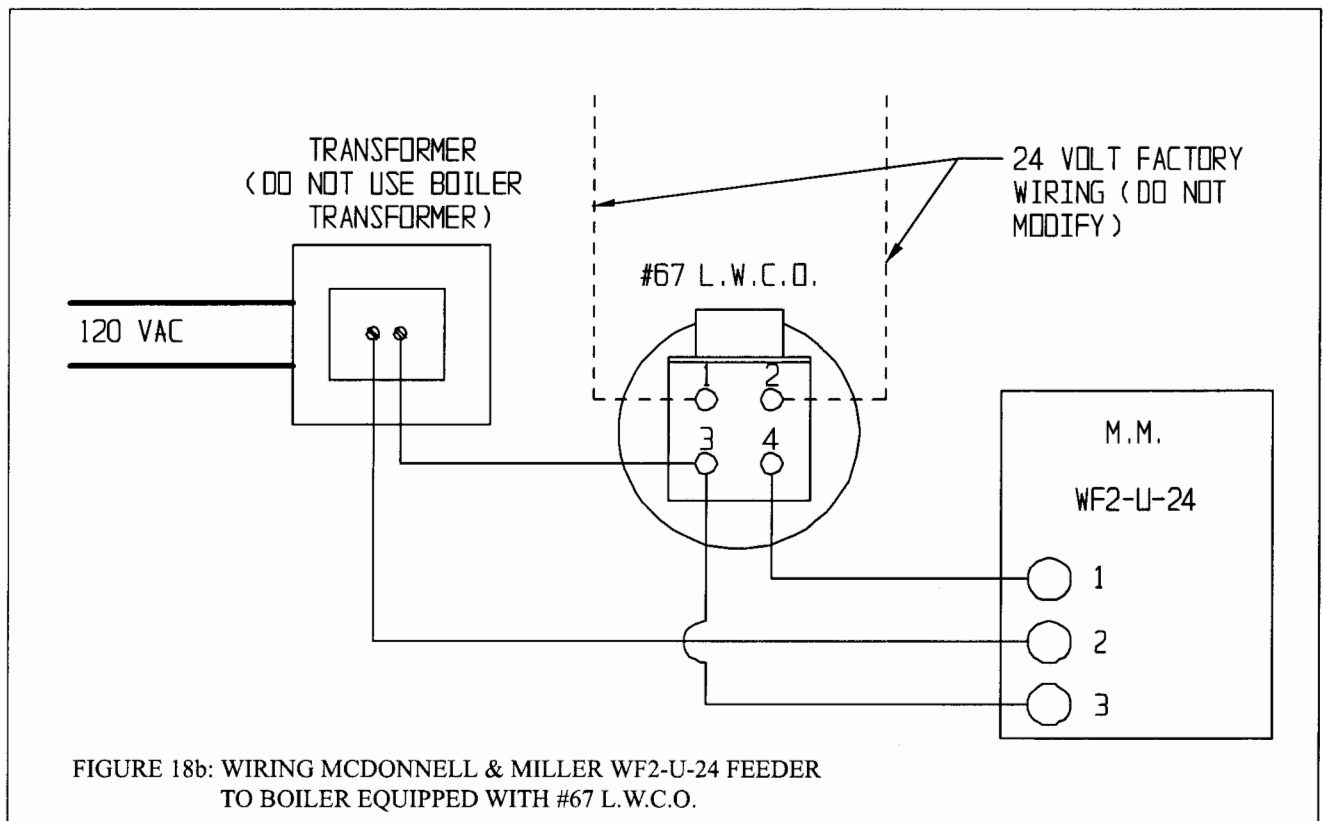

FIGURE 18b: WIRING MCDONNELL & MILLER WF2-U-24 FEEDER TO BOILER EQUIPPED WITH #67 L.W.C.O.

X Start-up and Checkout

NOTE

SAFE LIGHTING AND OTHER PERFORMANCE CRITERIA WERE MET WITH THE GAS MANIFOLD AND CONTROL ASSEMBLY PROVIDED ON THE BOILER WHEN THE BOILER UNDERWENT THE TESTS SPECIFIED IN Z21.13.

Use the following procedure for initial start-up of the boiler:

- 1) Make sure that the boiler is filled with water to the normal water line (26 inches above the floor or pad on which the boiler is installed)
- 2) Check all new gas piping for leaks and purge piping sections that are filled with air. See Part 4 of the *National Fuel Gas Code* for additional information on testing and purging gas lines.

WARNING

- NEVER USE A FLAME TO CHECK FOR GAS LEAKS.
- MAKE SURE THAT THE AREA AROUND THE BOILER IS CLEAR AND FREE FROM COMBUSTIBLE MATERIALS, GASOLINE, AND OTHER FLAMMABLE VAPORS AND LIQUIDS.

- 3) Verify that vent system is complete and free of obstructions before attempting to fire boiler.
- 4) Inspect all wiring for loose or uninsulated connections.
- 5) Remove the front jacket door. Remove and discard the pink foam strip between the burners and the burner access panel. Connect the loose wire taped in the vestibule area to the open terminal on the flame rollout switch.
- 6) Make sure the main burners are seated properly in the rear of burner tray and on orifices.
- 7) Adjust steam pressure limit control for a cut-in pressure of 0.5 psi and a differential pressure of 1 psi.
- 8) Adjust thermostat to the highest setting.
- 9) Start the boiler using the lighting instructions for boilers with standing pilot (page 25) or operating instructions for boilers with intermittent ignition (page 26).
- 10) Upon initial start-up, the gas train will be filled with air. Even if the gas line has been completely purged of air, it may take several tries for ignition before a flame is established. Once a flame has been established for the first time, subsequent calls for burner operation should result in a flame on the first try.
- 11) Observe pilot burner flame:
 - See Figure 21 for standing pilot. Pilot burner should produce single steady medium blue flame covering around 3/8" to 1/2" of thermocouple tip.
 - See Figure 22 for intermittent ignition. Pilot burner produces three flames. The center one should be a steady medium blue flame covering around 3/8" to 1/2" of spark electrode/flame rod.
- 12) Make sure vent damper is in open position when main burners are firing.
- 13) Inspect the main burner flames visible through the observation port in burner access panel. The flame should be stable and mostly blue (see Figure 23). No yellow tipping should be present; however, intermittent flecks of yellow and orange in the flame are normal.
- 14) Check entire gas train for leaks using soap and water or other approved leak detection method while boiler is firing. Fix any leaks found immediately.

13) Run gas valve safety shutdown test:

- For standing pilot boiler models, disconnect the thermocouple from gas valve. Both pilot burner and main burners should stop firing.
- For intermittent ignition boiler models, with main burners firing, disconnect ignition cable from ignition module. Both pilot burner and main burners should stop firing.

15) Check the manifold pressure and adjust if necessary. To do this, use the following procedure:

WARNING

FAILURE TO FOLLOW THE FOLLOWING PROCEDURE EXACTLY COULD RESULT IN OVER-FIRING OF THE BOILER AND A CARBON MONOXIDE HAZARD.

- a) Connect a manometer to the line pressure tap on the gas valve (see Figures 19 and 20).
- b) Check the line pressure with all gas appliances on and off. The line pressure at the boiler must be within the following limits regardless of what combination of appliances is firing:

Line Press (inches w.c.)	Natural Gas	LP Gas
Min.	5.0	11.0
Max.	14.0	13.0

If the line pressure falls outside of these limits, find and correct the cause of the problem before proceeding further.

- c) Connect a manometer to the manifold (outlet) pressure tap on the gas valve (see Figures 19 and 20).
- d) Read the manifold pressure. It should be set at:

	Natural Gas	LP Gas
Manifold Press. (inches w.c.)	3.5	10.0

- e) If a manifold pressure adjustment is needed, make the adjustment by turning the regulator (see Figures 24 and 25) screw clockwise to raise the pressure and counter clockwise to reduce the pressure. If a manifold pressure adjustment is made, recheck the line pressure to be certain that it is still within acceptable limits. Replace the cover screw on the regulator.

16) Test thermostat operation while the boiler is running. Turn the thermostat to the lowest setting. For standing pilot boiler models, pilot burner should remain lit but the main burners should stop firing. For intermittent ignition boiler models both pilot burner and main burners should stop firing. Raise the thermostat back to the highest setting. The main burners (for standing pilot boiler models) or pilot burner and main burners (for intermittent ignition boiler models) should relight.

17) Verify low water cutoff operation while the boiler is running. Slowly open drain valve and drain boiler until water level drops below low water cutoff line. Water still should be visible in the gauge glass when the low water cutoff shuts down the main burners. For standing pilot boiler models, pilot burner should remain lit when the main burners stop firing. For intermittent ignition boiler models both pilot burner and main burners should stop firing. Make sure pressure limit, thermostat or other controls have not shut off the boiler. Upon test completion refill the boiler to the normal water level.

18) Check pressure limit control operation. When steam pressure is registered on pressure gauge, lower pressure limit setting below gauge reading. For standing pilot boiler models, pilot burner should remain lit when the main burners stop firing. For intermittent ignition boiler models, both pilot burner and main burners should stop firing. Raise pressure limit setting above gauge reading. The main burners (for standing pilot boiler models) or pilot burner and main burners (for intermittent ignition boiler models) should relight.

FOR YOUR SAFETY READ BEFORE OPERATING

WARNING: If you do not follow these instructions exactly, a fire or explosion may result causing property damage, personal injury or loss of life.

- A. This appliance has a pilot which must be lighted by hand. When lighting the pilot, follow these instructions exactly.
- B. **BEFORE LIGHTING** smell all around the appliance area for gas. Be sure to smell next to the floor because some gas is heavier than air and will settle on the floor.
- WHAT TO DO IF YOU SMELL GAS**
- Do not try to light any appliance.
 - Do not touch any electric switch; do not use any phone in your building.
 - Immediately call your gas supplier from a neighbor's phone. Follow the gas supplier's instructions.
- If you cannot reach your gas supplier, call the fire department.
- C. Use only your hand to push in or turn the gas control knob. Never use tools. If the knob will not push in or turn by hand, don't try to repair it, call a qualified service technician. Force or attempted repair may result in a fire or explosion.
- D. Do not use this appliance if any part has been under water. Immediately call a qualified service technician to inspect the appliance and to replace any part of the control system and any gas control which has been under water.

LIGHTING INSTRUCTIONS

1. **STOP!** Read the safety information above on this label.
2. Set the thermostat to lowest setting.
3. Turn off all electric power to the appliance.
4. Remove front access panel.
5. Rotate the gas control knob clockwise ↻ to OFF.

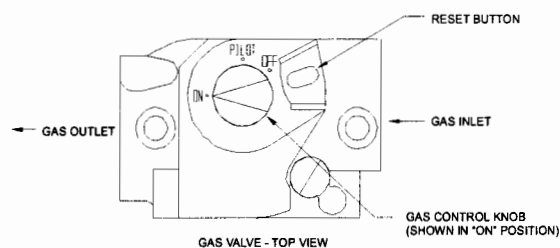

6. Wait five (5) minutes to clear out any gas. Then smell for gas, including near the floor. If you then smell gas, **STOP!** Follow "B" in the safety information above on this label. If you don't smell gas, go to the next step.
7. Find pilot - follow metal pilot tube from gas control to pilot burner.



8. Turn Knob on gas control counterclockwise ↺ to "PILOT".
9. Push down and hold the red reset button while you light pilot burner with a match. After about one minute, release reset button. Pilot should remain lit. If it goes out, turn gas control knob clockwise ↻ to OFF. To relight, repeat steps 5-9.
 - If button does not pop up when released, stop and immediately call your service technician or gas supplier.
 - If the pilot will not stay lit after several tries, turn the gas control knob to "OFF" and call your service technician or gas supplier.
10. After pilot remains lit when red reset button is released, turn gas control knob counterclockwise ↺ to ON.
11. Replace front access panel.
12. Turn on all electric power to the appliance.
13. Set thermostat to desired setting.

TO TURN OFF GAS TO APPLIANCE

1. Set the thermostat to lowest setting.
2. Turn off all electric power to the appliance if service is to be performed.
3. Push in gas control knob slightly and turn clockwise ↻ to "OFF". Do not Force.

FOR YOUR SAFETY READ BEFORE LIGHTING

WARNING: If you do not follow these instructions exactly, a fire or explosion may result causing property damage, personal injury or loss of life.

- A. This appliance is equipped with an ignition device which automatically lights the pilot. Do not try to light the pilot by hand.
- B. **BEFORE LIGHTING** smell all around the appliance area for gas. Be sure to smell next to the floor because some gas is heavier than air and will settle on the floor.

WHAT TO DO IF YOU SMELL GAS

- Do not try to light any appliance.
- Do not touch any electric switch; do not use any phone in your building.
- Immediately call your gas supplier from a neighbor's phone. Follow the gas supplier's instructions.

• If you cannot reach your gas supplier, call the fire department.

- C. Use only your hand to push in or turn the gas control knob. Never use tools. If the knob will not push in or turn by hand, don't try to repair it, call a qualified service technician. Force or attempted repair may result in a fire or explosion.
- D. Do not use this appliance if any part has been under water. Immediately call a qualified service technician to inspect the appliance and to replace any part of the control system and any gas control which has been under water.

OPERATING INSTRUCTIONS

1. **STOP!** Read the safety information above on this label.
2. Set the thermostat to lowest setting.
3. Turn off all electric power to the appliance.
4. This appliance is equipped with an ignition device which automatically lights the pilot. Do not try to light the pilot by hand.

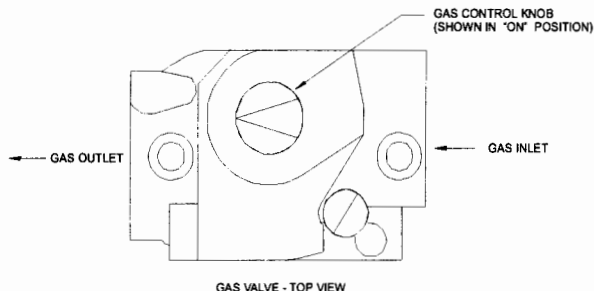

5. Remove front access panel.
6. Rotate the gas control knob clockwise ↻ to OFF.
7. Wait five (5) minutes to clear out any gas. Then smell for gas, including near the floor. If you then smell gas, STOP! Follow "B" in the safety information above on this label. If you don't smell gas go to the next step.
8. Rotate the gas control knob counter clockwise ↺ to "ON".
9. Replace front access panel.
10. Turn on all electric power to the appliance.
11. Set thermostat to desired setting.
12. If the appliance will not operate, follow the instructions "To Turn Off Gas To Appliance" and call your service technician or gas supplier.

TO TURN OFF GAS TO APPLIANCE

1. Set the thermostat to lowest setting.
2. Turn off all electric power to the appliance if service is to be performed.
3. Push in gas control knob slightly and turn clockwise ↻ to "OFF". Do not Force.

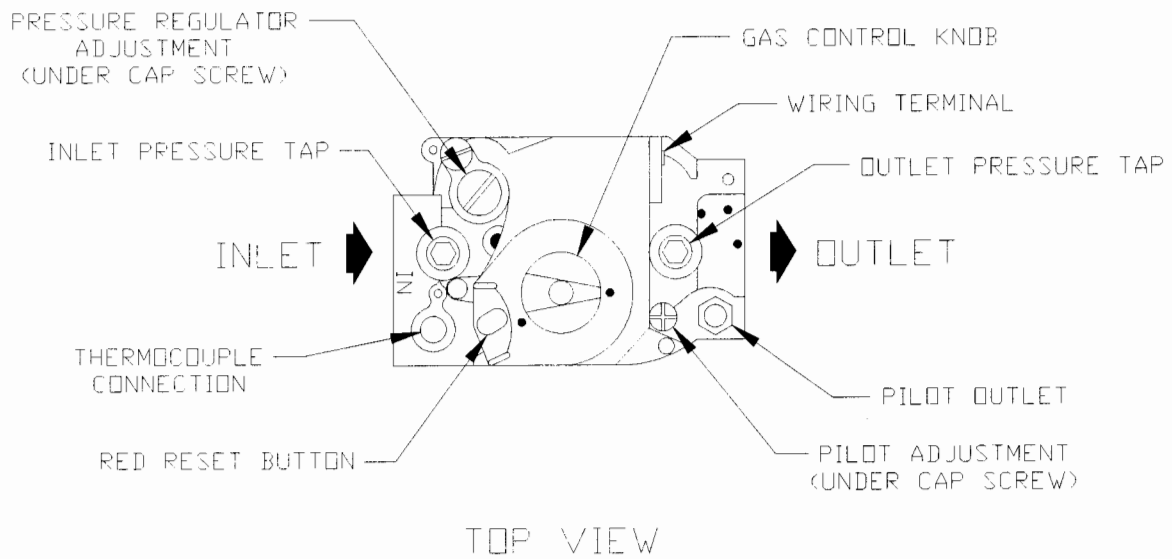

FIGURE 19: GAS VALVE DETAIL - STANDING PILOT

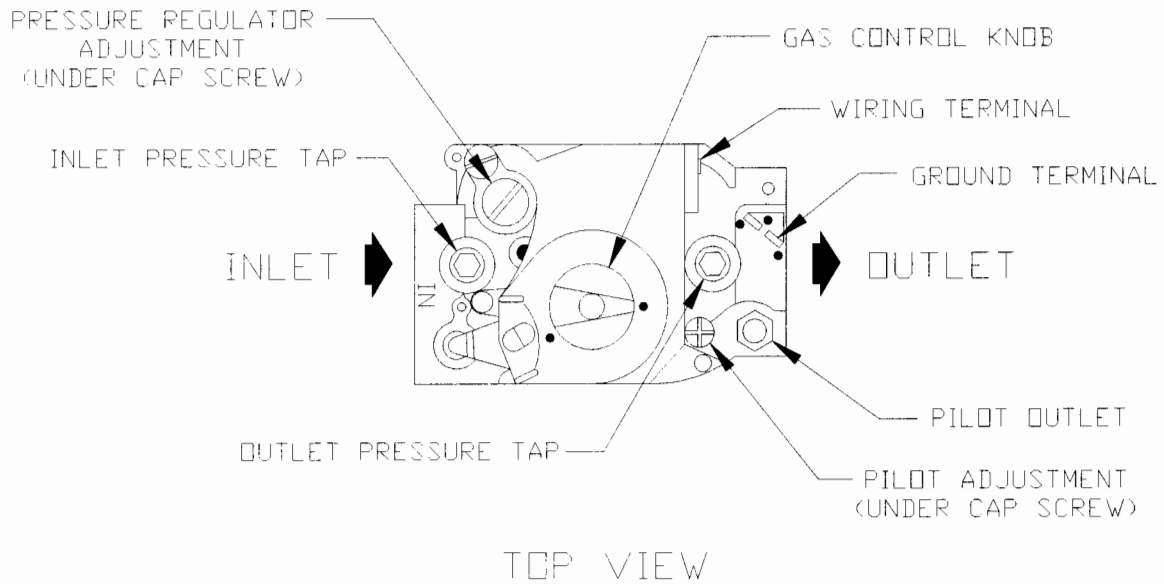

FIGURE 20: GAS VALVE DETAIL - INTERMITTENT IGNITION

19) After the boiler has operated for approximately 30 minutes, check the boiler and heating system piping for leaks. Repair any leaks found at once.

20) Inspect the vent system for flue gas leaks. Repair any leaks found before leaving the boiler in operation.

21) Replacement of a steam boiler tends to break loose accumulated scale from the system. During the first week of operation, blow down the #67 low water cut-off at least three times following the blow down instructions on the yellow sticker adjacent to the low water cut-off.

22) After new boiler has been installed and put into continuous operation for several days, clean the boiler of oil, grease, sludge, and other contaminants that may have been present in existing piping. This will prevent unsteady water line and water carry over into supply main. The boiler boil-out should be done as follows:

- a) Turn off gas supply to boiler per the appropriate Lighting and Operating instructions on page 25 or 26.
- b) Drain water from boiler until about one inch of water is visible in gauge glass.
- c) Run a hose or temporary piping from the boiler drain valve to a location where hot water can be safely discharged. Drain approximately five gallons of water from the boiler and mix-in an appropriate amount of an approved boil-out compound. Remove safety valve and refill the boiler with prepared solution thru funnel inserted into elbow under the safety valve. Run a hose or temporary piping from safety valve tapping to a location where hot water can be safely discharged. **DO NOT INSTALL ANY VALVES IN THIS LINE.**
- d) Light off the boiler per the appropriate instructions on page 25 or 26. Run boiler for several hours, boiling the water, without generating steam pressure. Open the water feed valve sufficiently to allow a slight overflow of water through the safety valve tapping drain line. Continue boiling until water coming out is clear.
- e) Turn off gas supply to boiler per the appropriate Lighting and Operating instructions on page 25 or 26. Drain hot water from boiler thru boiler drain valve to a location where hot water can be safely discharged. Refill the boiler to normal water line level. If water in the gauge glass does not look clear, repeat above boil-out procedure again until water clears out.
- f) Reinstall safety valve and related piping.
- g) Conduct pH and Alkalinity test of water in the system. The pH reading should be in 7 to 11 range.

NOTE

When substantial amount of make-up water is used due to lost condensate, or when make-up water is hard or corrosive, water treatment is required. Contact qualified water treatment company for recommended water treatment compounds and procedure.

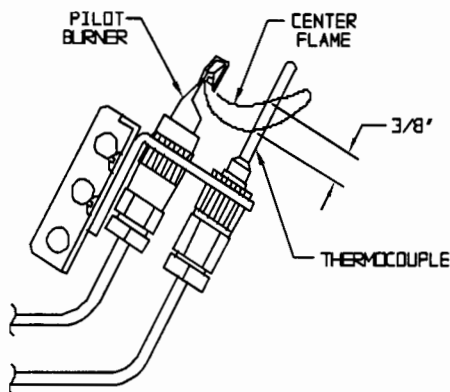

FIGURE 21: STANDING PILOT BURNER FLAME

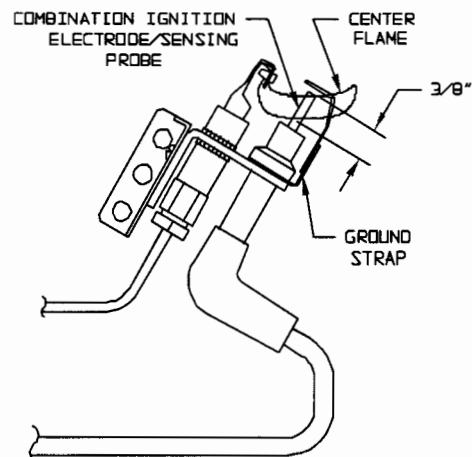

FIGURE 22: INTERMITTENT IGNITION PILOT BURNER FLAME

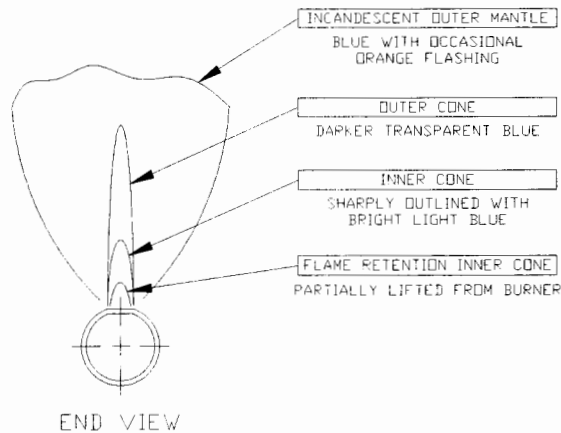

FIGURE 23: MAIN BURNER FLAME

XI Service and Maintenance

On at least a weekly basis:

For boilers equipped with a #67 low water cut-off, blow down the low water cut-off following the instructions on the yellow sticker adjacent to the low water cut-off. During this blow down, the low water cutoff should shut down the burners. If it does not the low water cut-off should be replaced immediately.

On an annual basis:

- 1) Turn off electrical power and gas supply to the boiler
- 2) Inspect the flue passages for signs of blockage. If there is any carbon in the combustion chamber or the flue passages, clean the heat exchanger before proceeding further. See the cleaning procedure below.
- 3) Remove any debris found in the combustion chamber, being careful not to disturb combustion chamber insulation.
- 4) Remove all burners, noting the location of the pilot main burner. If burners show signs of deterioration, they should be replaced (some discoloration around the burner ports is normal). Clean the burners by first brushing the ports with a soft bristle brush and then vacuuming out any debris through the venturi opening.
- 5) Inspect the pilot assembly:
 - **Standing Pilots** - Check the thermocouple for deterioration (some discoloration of the thermocouple is normal). If any deterioration is present, replace the thermocouple. Inspect the pilot assembly for deposits and deterioration. Clean or replace the pilot assembly as necessary.
 - **Intermittent Pilots** - Clean any deposits found on the electrode and grounding strap. The ideal gap between the electrode and the ground strap is 1/8". Inspect the porcelain for cracks or other deterioration. Replace pilot assembly if deterioration is found.
- 6) Inspect the combustion chamber insulation for deterioration.

CAUTION

LABEL ALL WIRES PRIOR TO DISCONNECTION WHEN SERVICING CONTROLS. WIRING ERRORS CAN CAUSE IMPROPER AND DANGEROUS OPERATION. VERIFY PROPER OPERATION AFTER SERVICING

- 7) (Intermittent Pilot Boilers) - Inspect the ignition cable insulation for cracks or other deterioration. If deterioration is found, replace cable.
- 8) Reinstall burners, being careful to put the pilot main burner in its original location.
- 9) Inspect all boiler wiring for loose connections or deterioration.
- 10) Inspect the vent system:

- Make sure that both the vent system is free of obstructions.
- Make sure that all vent system supports are intact.
- Inspect joints for signs of condensate or flue gas leakage.
- Inspect venting components for corrosion or other deterioration. Replace any defective vent components.

- 11) Inspect the boiler and system for leaks.
- 12) Inspect the low water cut-off:

- For Hydrolevel CG400A low water cut-offs - Remove and inspect the probe for scale and sediment buildup. Clean any sediment or scale from the probe with a scouring pad or steel wool. Consult the Hydrolevel! CG400 manual for any additional maintenance information. Test the low water cut-off before placing the boiler back into service.
- For McDonnell & Miller #67 low water cut-offs - Remove and inspect switch and float mechanism. Inspect float bowl for mud accumulation. Clean as required. Replace the switch and float mechanism every five years or 100,000 cycles. Consult the McDonnell and Miller #67 manual for any additional maintenance information. Test the low water cut-off before placing the boiler back into service.

13) Allow the boiler to cool to room temperature. Remove the drain valve and 2 x 3/4 bushing on the left side of the boiler. Use a flashlight to inspect the bottom row of push nipples for accumulated scale or mud. If a significant amount is present, use the following procedure to clean the inside of the heat exchanger:

- a) Temporarily install a 1 1/4 inch or larger full port ball valve in place of the boiler drain. Temporarily pipe the outlet of this valve to a location where hot water and steam can be safely discharged.
- b) Make sure that this valve is closed and that the water level is at the normal water line.
- c) If a king valve is present in the steam main takeoff, close it. Alternatively, temporarily replace enough of the vents on the mains and/or radiators with plugs so that 2-5 psi can be developed when the boiler is fired.
- d) Fire the boiler and allow it to steam until 2-5 psi is registered on the gauge.
- e) Turn off the burners and immediately fully open the 1-1/4 valve.
- f) Allow the boiler to blow down until either the water runs clear or the water level reaches the bottom of the gauge glass.
- g) Allow all parts of the boiler to cool to room temperature. Drain the boiler completely and remove the 1-1/4 valve.
- h) If significant mud or scale is still present in the bottom of the boiler, repeat steps (b) through (g) until all mud or scale is removed.
- i) Once all mud or scale is removed, replace the 1-1/4 valve and temporary blow-down piping with the standard drain valve. After all parts of the boiler are at room temperature, refill the boiler to the normal water line.

NOTE

A large accumulation of mud or scale in the bottom of the heat exchanger is usually a sign of excessive feedwater make-up. Such accumulations can cause severe heat exchanger damage. If mud or scale accumulations are found:

- Make sure that all vents are in working order. Vents should not permit any passage of steam or water.
- Check all steam and return piping for leaks. Be aware that buried return piping can leak and go undetected during normal operation.

14) Place the boiler back in operation using the procedure outlined in "Start-up". Check the pilot line and any other gas piping disturbed during the inspection process for leaks.

Heat Exchanger Cleaning Procedure

- 1) Turn off electrical power and gas supply to the boiler
- 2) Disconnect the damper and vent connector from the boiler.
- 3) On JSE boilers, remove the blocked vent (“spill”) switch and drafthood.
- 4) Remove the upper front (on JSI boilers) and top jacket panels. If possible, remove the rear and left side jacket panels
- 5) Remove the burners.
- 6) On JSI boilers, remove the blocked vent (“spill”) switch
- 7) Remove the two ¼-20 nuts and washers holding the flue collector onto the heat exchanger.
- 8) Remove the flue collector from the heat exchanger.
- 9) Clean the flue passageways using a stiff bristle brush. Be certain that all foreign material is removed from the gaps between the pins
- 10) Clean the bottom surfaces of the heat exchanger
- 11) Put a light in the combustion chamber and look through the flue passages from the top to verify that they have been thoroughly cleaned.
- 12) Seal the flue collector to the heat exchanger using RTV-732 silicone sealant with a 500F intermittent duty temperature. The flue collector must be thoroughly sealed to the heat exchanger including the seam on the front of the heat exchanger.
- 13) Replace the ¼-20 nuts and washers that hold down the flue collector
- 14) Reattach all the jacket components.
- 15) Reinstall burners, being careful to put the pilot main burner in its original location.
- 16) On JSI boilers, replace the blocked vent switch.
- 17) On JSE boilers, reinstall the drafthood. Reinstall the blocked vent switch on the skirt of the drafthood as shown in Figure 9.
- 18) Reconnect the damper and vent system.

WARNING

SOOT DEPOSITS IN THE FLUE PASSAGES ARE A SIGN THAT THE BOILER MAY BE OPERATING AT HIGH CARBON MONOXIDE (CO) LEVELS. AFTER CLEANING THE BOILER OF SOOT DEPOSITS, CHECK THE CO LEVEL IN THE FLUE GAS TO INSURE THAT THE BOILER IS OPERATING PROPERLY.

If it is necessary to check CO, use a combustion analyzer, or other instrument which is designed to measure CO in flue gas. A CO “sniffer” designed for testing CO levels in ambient air cannot be used to check boiler combustion. Take a flue gas sample by inserting a sample probe through the draft diverter or draft hood opening and into the flue collector so that the sample is taken in the area directly over the heat exchanger. Do not take a sample until the boiler has been firing for at least five minutes.

A normal CO reading for an JSI or JSE series boiler is less than 50ppm (0.005%). A reading of more than 100ppm (0.01%) is indicative of a combustion problem.

Some causes of excessive CO include:

- Incorrectly sized main burner orifice for the altitude at which boiler is installed
- Crooked or out-of-round orifice holes (never attempt to drill orifice for this boiler in the field)
- Partially plugged flue passages
- Improper manifold pressure
- Foreign material in burner venturis or burner ports
- Leak in seal between flue collector and heat exchanger
- Inadequate supply of combustion air
- (JSE Boilers) Drafthood which has been cut or modified

XII Troubleshooting

The following pages contain troubleshooting charts for use in diagnosing control problems. To use these charts, go to the box marked "Start" at the top of the chart on page 33 and follow the appropriate path through the chart until a box with a list of possible causes is reached. If the problem is known to be within the ignition system, go directly to the appropriate troubleshooting guide for the boiler (standing pilot on page XX or intermittent ignition on page XX). In using these charts, the following should be kept in mind:

- 1) These charts are only meant to be used by a professional heating technician as an aid in diagnosing control problems.
- 2) Where applicable, follow all precautions outlined in the appropriate lighting instructions on page 25 or 26.
- 3) In general, these charts assume that there are no loose or miswired electrical connections. Before using these charts, inspect all electrical connections on the boiler to make sure that they are tight. Also, check the wiring on the boiler against the appropriate wiring diagram in Figures 14 - 17.
- 4) The possible causes at the end of each branch in these charts are not listed in order of likelihood. All controls on the JSI and JSE are tested at least once in the manufacturing process and a defective control or component is generally the least likely cause. Before replacing a component, try to rule out all other possible causes.
- 5) These troubleshooting charts assume that the vent damper is closed at the beginning of the troubleshooting process. With the 120 volts applied to the boiler and no call for heat, the damper should go to the closed position. If it does not, do the following:
 - Confirm that 120 volts is applied to the boiler and that there is no call for heat.
 - Make sure that the switch on the damper is in the "automatic" position.
 - Unplug the harness from the damper and check for 24 volts across pin #1 (blue) and pin #4 (yellow).
 - If voltage is present, the damper is defective or there is an obstruction in the path of the damper blade.
 - If no voltage is present, there is either a loose connection in the damper harness or the transformer is defective
- 5) If the charts indicate that the transformer is defective, it is possible that this transformer has been destroyed by a short circuit in the boiler wiring. Before replacing the transformer, carefully inspect all low voltage wiring on the boiler for places where it is touching the frame of the boiler or wiring on the other side of the transformer.
- 6) If the charts indicate that the R8225 relay is defective, there is a good chance that a second transformer is present in the thermostat circuit, resulting in the application of 48 volts across the relay coil. In older buildings, this transformer may be hidden in a location far from the boiler. If this second transformer exists, it must be found and removed before the R8225 is replaced.
- 7) When checking voltage across damper harness pins, be careful not to insert the meter probes into the pins. Doing so may damage the pin, resulting in a loose connection when the harness is reconnected.

Troubleshooting Chart for JSI or JSE Boilers Equipped with Hydrolevel CG400A Low Water Cut-offs

Caution: Read page 32 before attempting to use this chart

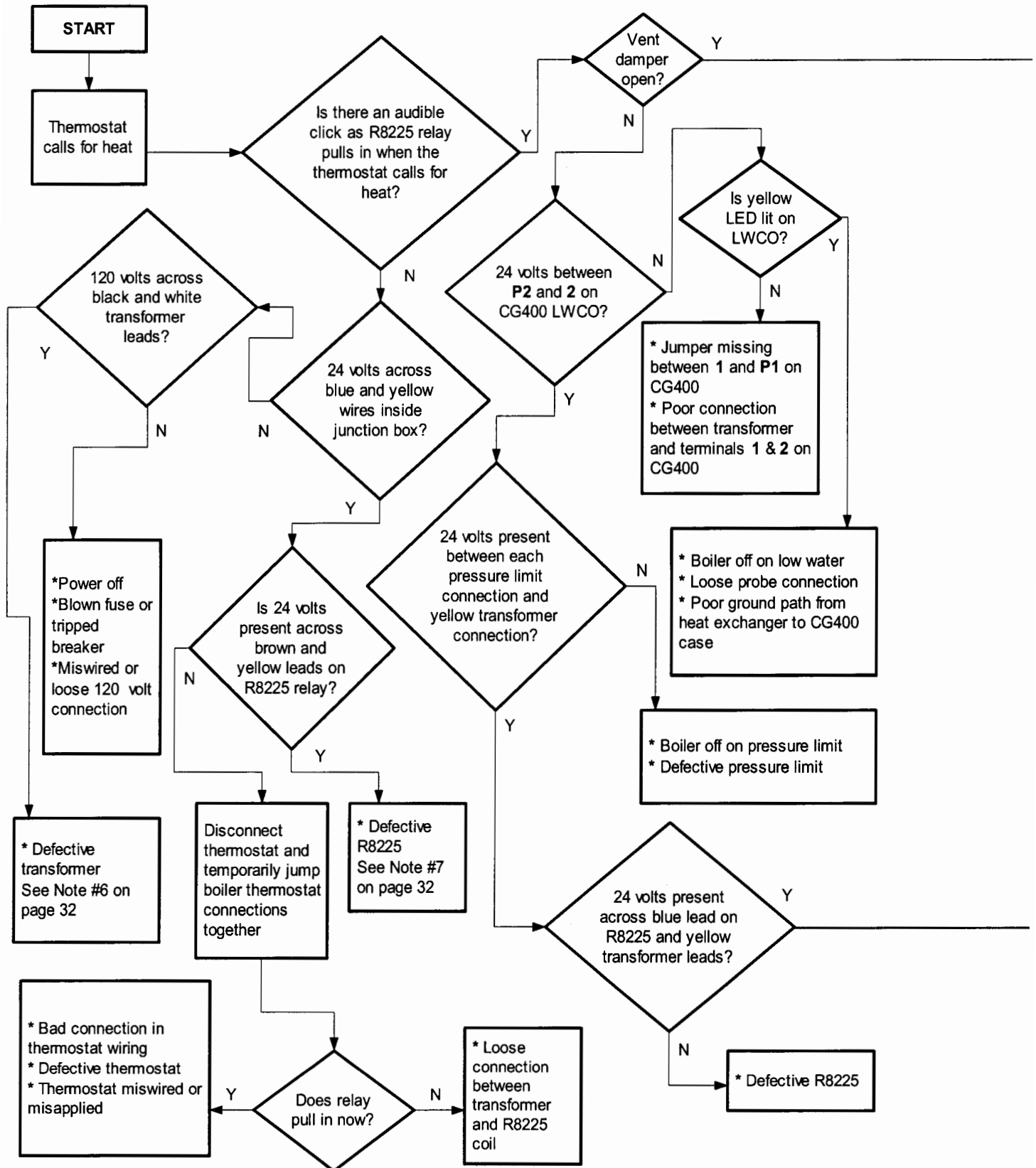

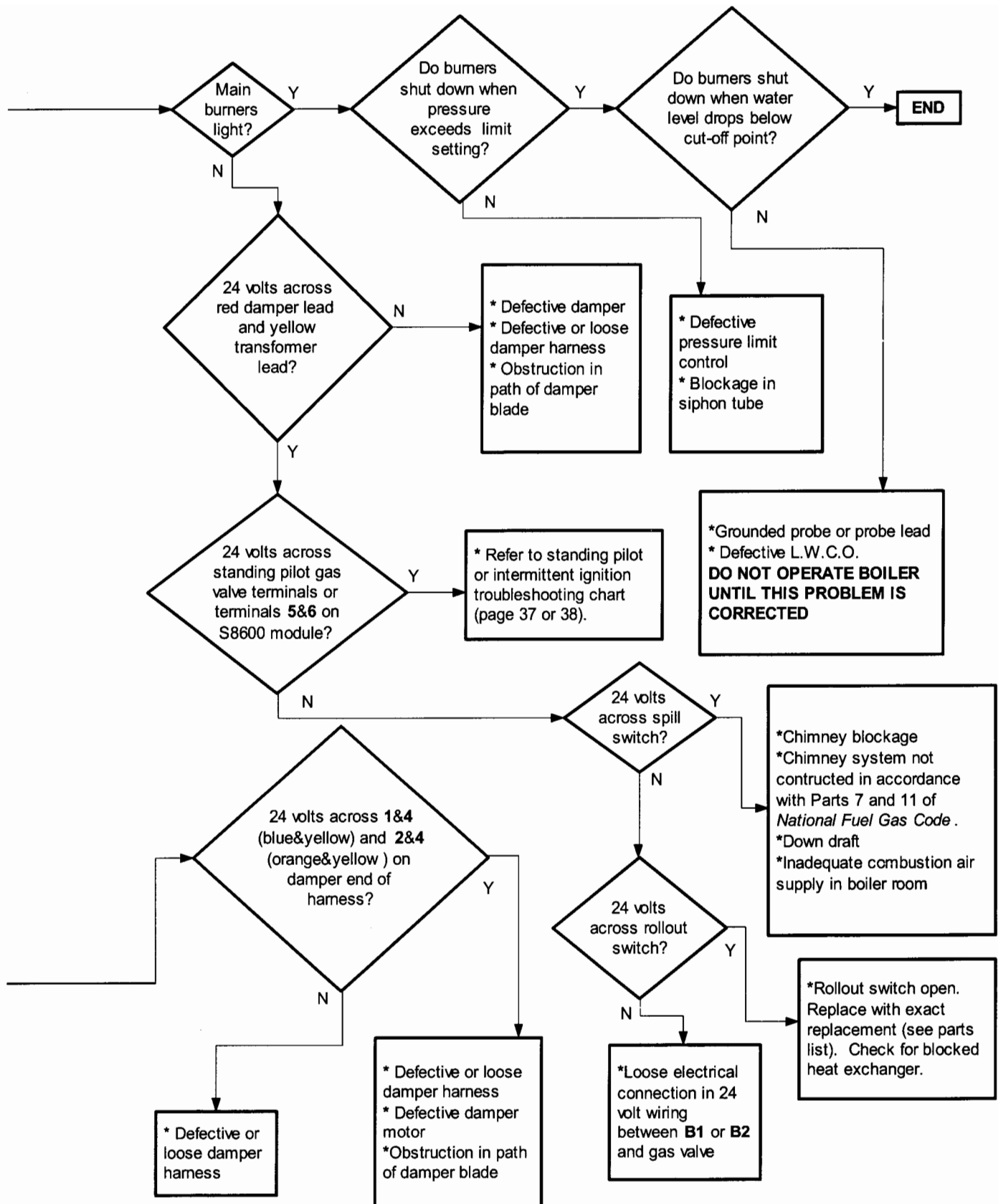

Troubleshooting Chart for JSI or JSE Boilers Equipped with McDonnell & Miller #67 Low Water Cut-offs

Caution: Read page 32 before attempting to use this chart

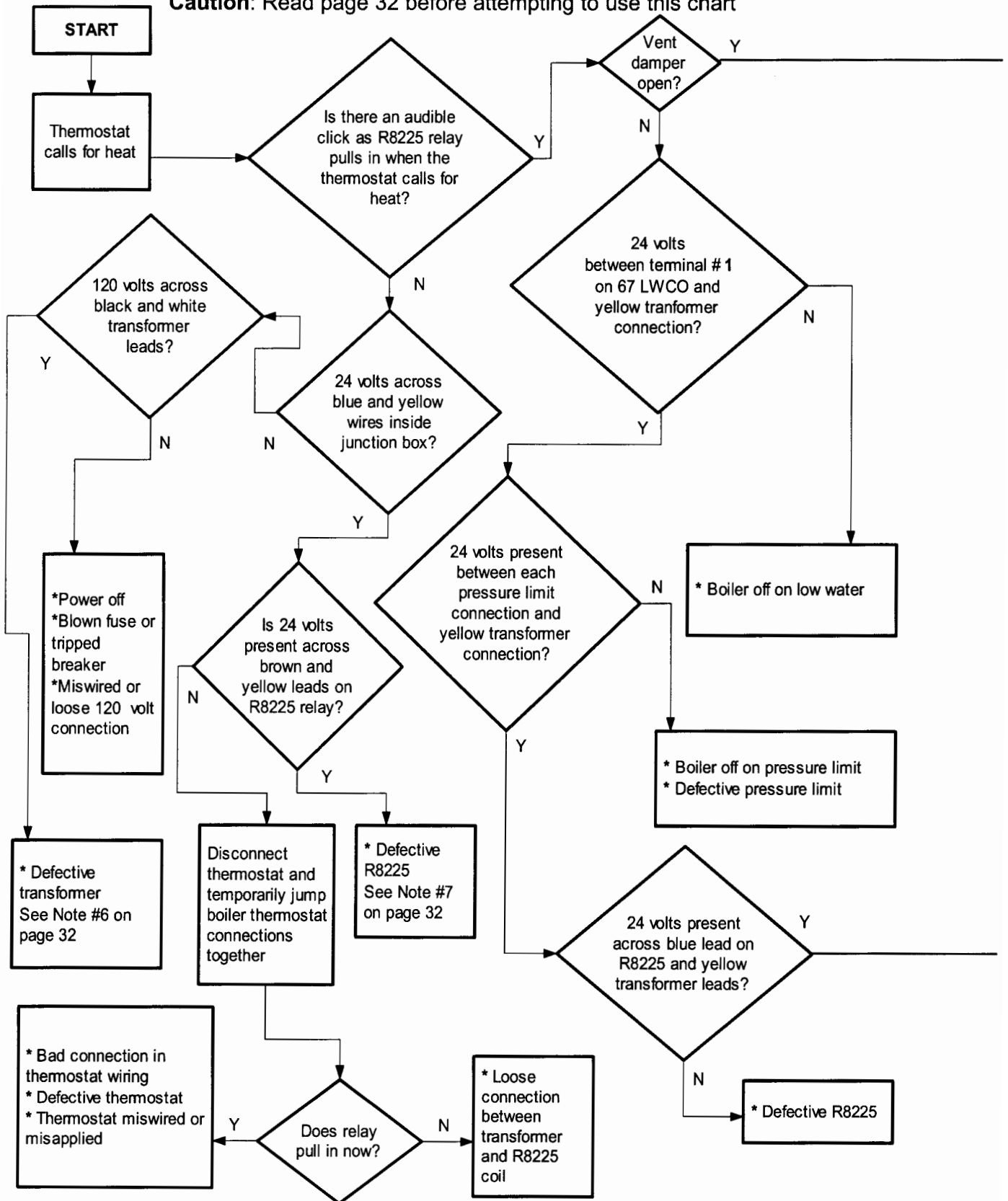

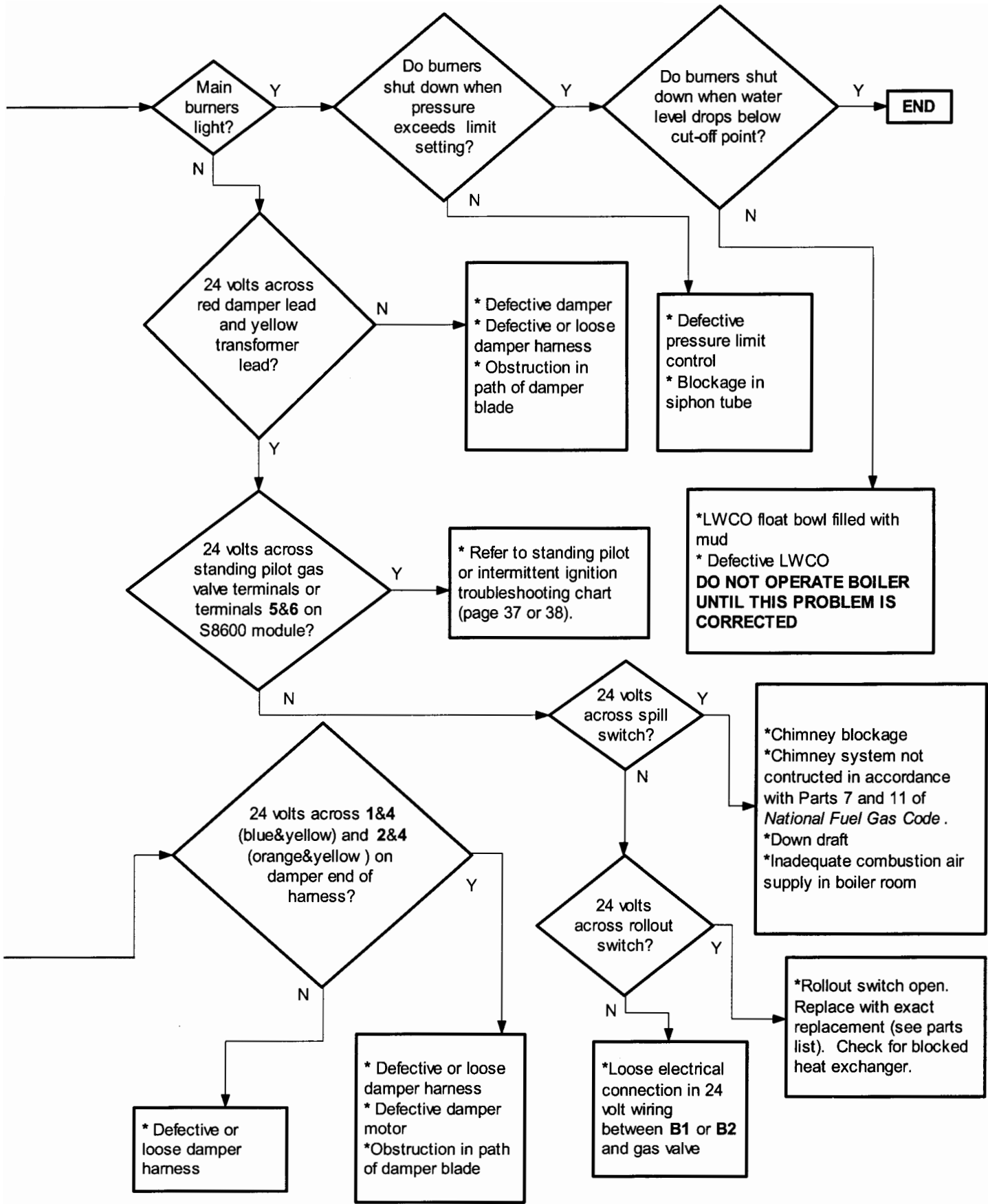

Standing Pilot Ignition System Troubleshooting Chart

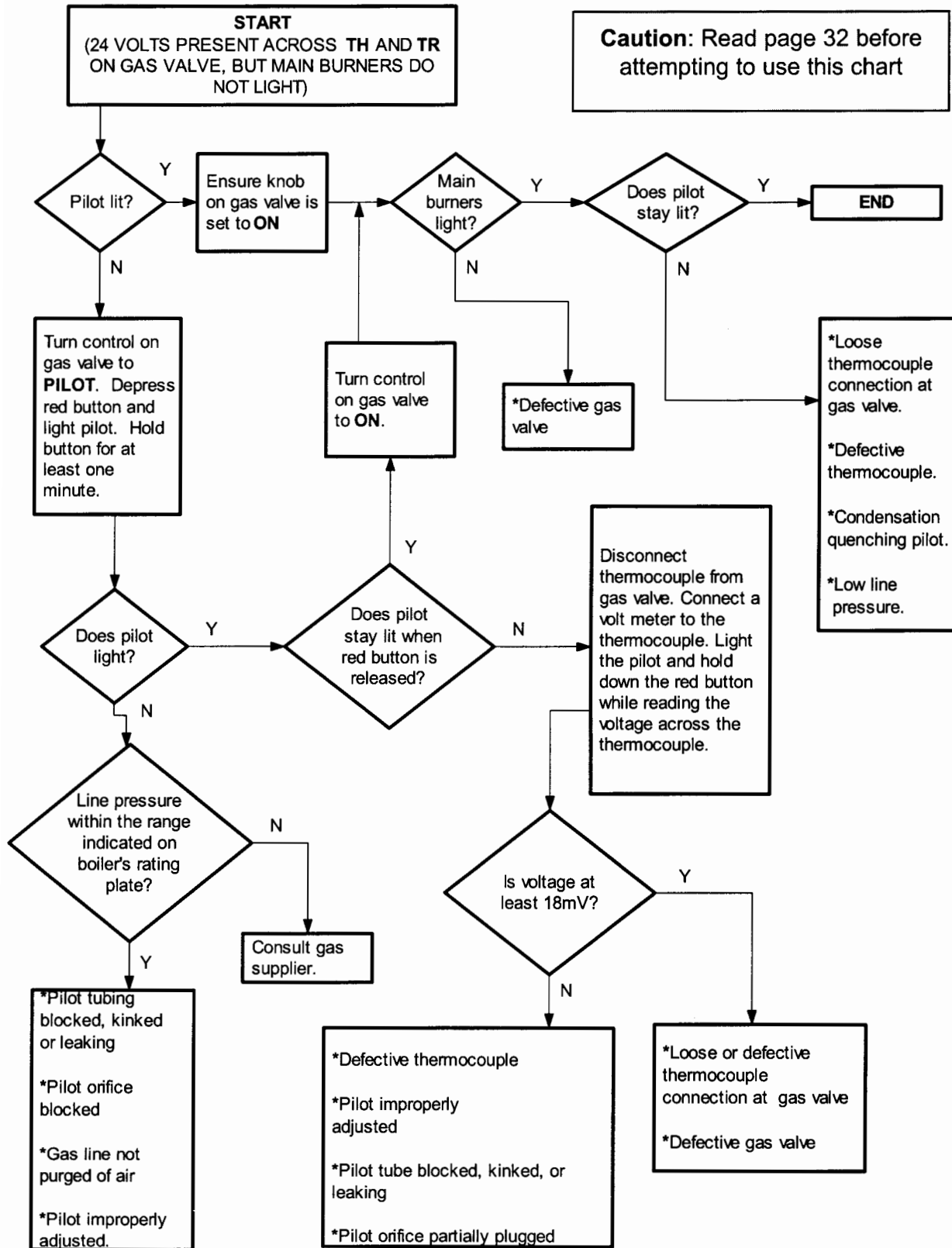

Intermittent Ignition System Troubleshooting Chart

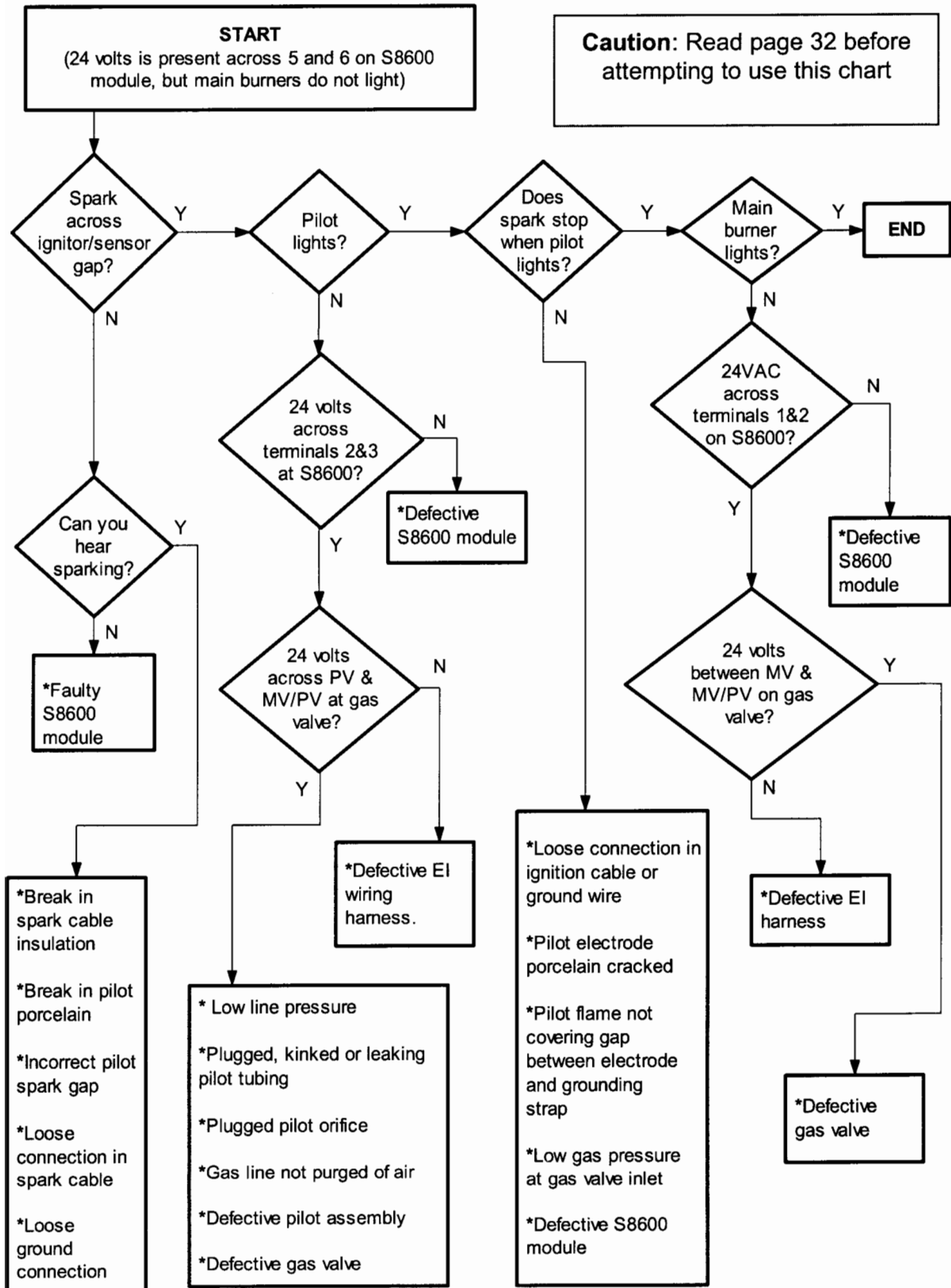

XIII PARTS

The following parts may be obtained from any Crown distributor. To find the closest Crown distributor, consult the area Crown representative or the factory at:

Crown Boiler Co.
Customer Service
P.O. Box 14818
Philadelphia Pa. 19134
www.crownboiler.com

Main burner orifice shown are for sea level configured boilers. For boilers installed at elevations above 2000 ft, consult the local Crown representative or the factory for the correct main burner orifice.

In some cases, the following parts lists do not include Crown part numbers because they were not available at the time of printing. Order these parts by their description, specifying the boiler model number on which they are to be used.

KEY #	DESCRIPTION	QTY. OR CROWN P.N.	QUANTITY PER BOILER OR CROWN P.N.									
			69	103	138	172	207	241	276	310	345	379
1	COMPLETE HEAT EXCHANGER ASSY.	1 ea.	800013	800014	800015	800016	800017	800018	800019	800020	800021	800022
*	LEFT END SECTION	800001	1 ea.	1 ea.	1 ea.	1 ea.	1 ea.	1 ea.	1 ea.	1 ea.	1 ea.	1 ea.
*	RIGHT END SECTION	800002	1 ea.	1 ea.	1 ea.	1 ea.	1 ea.	1 ea.	1 ea.	1 ea.	1 ea.	1 ea.
*	INTERMEDIATE SECTION	800003	1 ea.	2 ea.	3 ea.	4 ea.	5 ea.	6 ea.	7 ea.	8 ea.	9 ea.	10 ea.
*	UPPER PUSHNIPPLE	800005	2 ea.	3 ea.	4 ea.	5 ea.	6 ea.	7 ea.	8 ea.	9 ea.	10 ea.	11 ea.
*	LOWER PUSHNIPPLE	800000	2 ea.	3 ea.	4 ea.	5 ea.	6 ea.	7 ea.	8 ea.	9 ea.	10 ea.	11 ea.
2	BASE TRAY	1 ea.	800643	800644	800645	800646	800647	800648	800649	800650	800651	800652
3	LEFT END BASE PANEL	800661	1 ea.	1 ea.	1 ea.	1 ea.	1 ea.	1 ea.	1 ea.	1 ea.	1 ea.	1 ea.
4	RIGHT END BASE PANEL	800660	1 ea.	1 ea.	1 ea.	1 ea.	1 ea.	1 ea.	1 ea.	1 ea.	1 ea.	1 ea.
5	REAR BASE PANEL	1 ea.	800663	800664	800665	800666	800667	800668	800669	800670	800671	800672
6	FRONT BASE PANEL (INCLUDES INSULATION)	1 ea.	800603	800604	800605	800606	800607	800608	800609	800610	800611	800612
7	BURNER ACCESS PANEL (INCLUDES INSULATION)	1 ea.	800623	800624	800625	800626	800627	800628	800629	800630	800631	800632
8	BASE END INSULATION	820601	2 ea.	2 ea.	2 ea.	2 ea.	2 ea.	2 ea.	2 ea.	2 ea.	2 ea.	2 ea.
9	BASE REAR INSULATION	1 ea.	820603	820604	820605	820606	820607	820608	820609	820610	820611	820612
10	BURNER TRAY	1 ea.	800683	800684	800685	800686	800687	800688	800689	800690	800691	800692
11	JACKET SUPPORT BRACKET	800302	2 ea.	2 ea.	2 ea.	2 ea.	2 ea.	2 ea.	2 ea.	2 ea.	2 ea.	2 ea.
12	1/2" x 2" SEALING STRIP	900146	7.0 ft.	7.6 ft.	8.2 ft.	8.8 ft.	9.4 ft.	10 ft.	10.6 ft.	11.2 ft.	11.8 ft.	12.3 ft.
13	#10 X 2 CUP HEAD PIN	900202	4 ea.	4 ea.	4 ea.	4 ea.	4 ea.	4 ea.	4 ea.	4 ea.	4 ea.	4 ea.
14	#10 X 1-5/8 CUP HEAD PIN	900201	1 ea.	1 ea.	1 ea.	2 ea.	2 ea.	2 ea.	3 ea.	3 ea.	4 ea.	4 ea.
15	1-1/4 X 1-1/8 SPEED NUT	900200	5 ea.	5 ea.	5 ea.	6 ea.	6 ea.	6 ea.	7 ea.	7 ea.	8 ea.	8 ea.
16	5/16 USS FLAT WASHER	900102	8 ea.	8 ea.	8 ea.	8 ea.	8 ea.	8 ea.	8 ea.	8 ea.	8 ea.	8 ea.
17	5/16-18 BRASS HEX NUT	900104	4 ea.	4 ea.	4 ea.	4 ea.	4 ea.	4 ea.	4 ea.	4 ea.	4 ea.	4 ea.
18	#10 X 1/2 TRUSS HD SCREW	900120	2 ea.	2 ea.	2 ea.	2 ea.	2 ea.	2 ea.	2 ea.	2 ea.	2 ea.	2 ea.
19	ROLLOUT SWITCH G4AM0600240C	960122	1 ea.	1 ea.	1 ea.	1 ea.	1 ea.	1 ea.	1 ea.	1 ea.	1 ea.	1 ea.
20	ROLLOUT SWITCH BRACKET	900121	1 ea.	1 ea.	1 ea.	1 ea.	1 ea.	1 ea.	1 ea.	1 ea.	1 ea.	1 ea.
21	#8 x 3/4" SELF TAPPING SCREW	90-048	1 ea.	1 ea.	1 ea.	1 ea.	1 ea.	1 ea.	1 ea.	1 ea.	1 ea.	1 ea.
22	#10 x 1/2" SHEET METAL SCREW	90-212	2 ea.	2 ea.	2 ea.	2 ea.	2 ea.	2 ea.	2 ea.	2 ea.	2 ea.	2 ea.
23	1/4-20 X 1/2" SELF TAPPING SCREW	900100	18 ea.	19 ea.	20 ea.	21 ea.	22 ea.	23 ea.	24 ea.	25 ea.	26 ea.	27 ea.
24	1/4-20 BRASS WING NUT	900125	4 ea.	4 ea.	4 ea.	4 ea.	4 ea.	4 ea.	4 ea.	4 ea.	4 ea.	4 ea.
25	5/16-18 LOCK NUT	900103	4 ea.	4 ea.	4 ea.	4 ea.	4 ea.	4 ea.	4 ea.	4 ea.	4 ea.	4 ea.
26	DRAFT DIVERTER ASSEMBLY (JSI)	1 ea.	800123	800124	800125	800126						
27	FLUE COLLECTOR (JSE)	1 ea.					800127	800128	800129	800130	800131	800132
28	JSE DRAFT HOOD (NAT GAS)	1 ea.					800137	800138	800139	800140	800141	800142
28	JSE DRAFT HOOD (LP GAS)	1 ea.					8001375	8001385				
29	BLOCKED VENT SWITCH ASSY. (INCLUDES MOUNTING BRACKET)	960123	1 ea.	1 ea.	1 ea.	1 ea.	1 ea.	1 ea.	1 ea.	1 ea.	1 ea.	1 ea.
30	1/4-20 x 3" CARRIAGE BOLT	900126	2 ea.	2 ea.	2 ea.	2 ea.	2 ea.	2 ea.	2 ea.	2 ea.	2 ea.	2 ea.
31	1/4" USS FLAT WASHER	90-215	2 ea.	2 ea.	2 ea.	2 ea.	2 ea.	2 ea.	2 ea.	2 ea.	2 ea.	2 ea.
*	10.1 oz TUBE SILICONE SEALANT	90-045	1 ea.	1 ea.	1 ea.	1 ea.	1 ea.	1 ea.	1 ea.	1 ea.	1 ea.	1 ea.

* NOT PICTURED

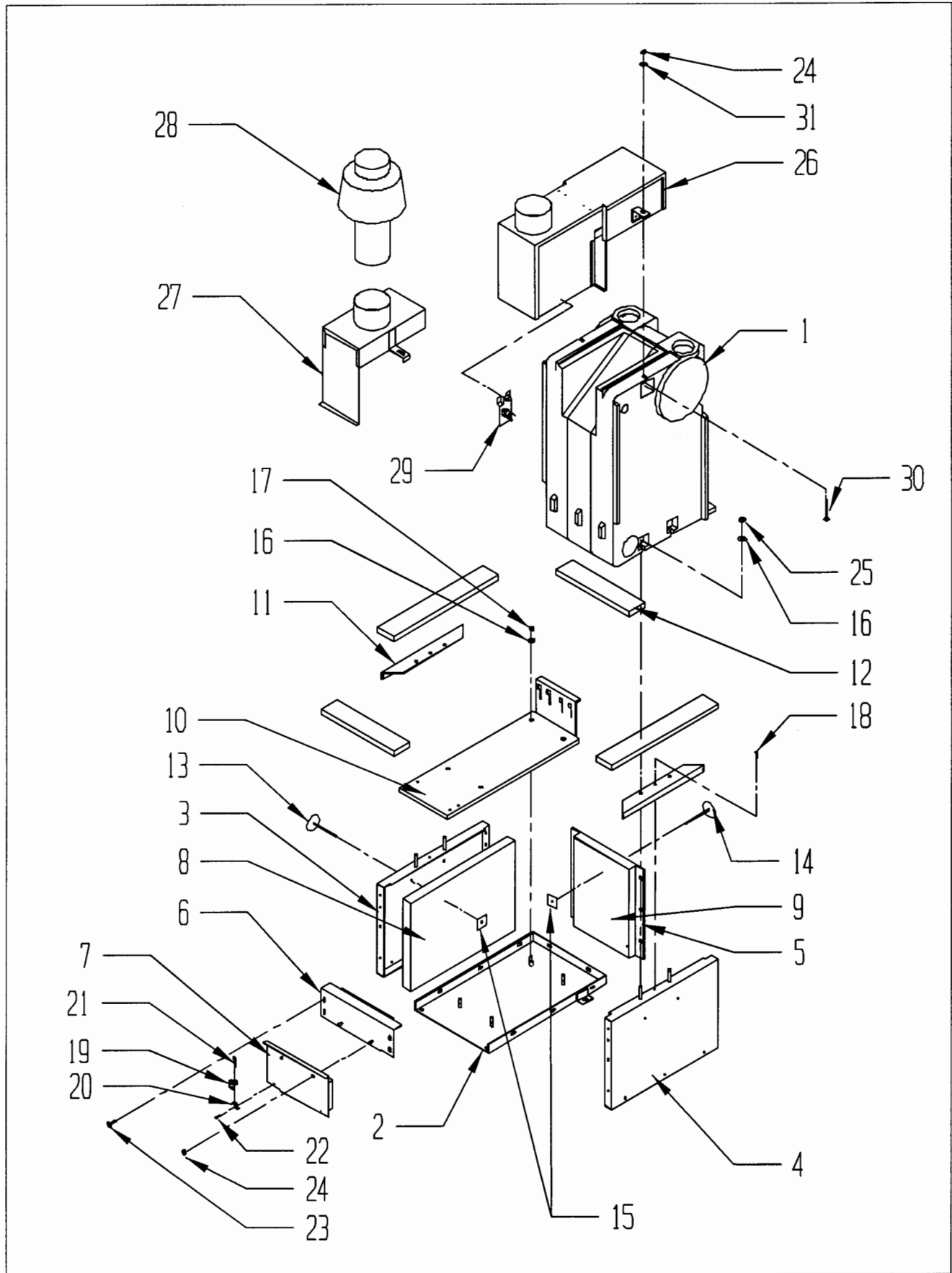

KEY #	DESCRIPTION	QTY. OR CROWN P.N.	QUANTITY PER BOILER OR CROWN P.N.									
			69	103	138	172	207	241	276	310	345	379
41	1" BURNER WITH PILOT BRACKET	150500	1 ea.	1 ea.	1 ea.	1 ea.	1 ea.	1 ea.	1 ea.	1 ea.	1 ea.	1 ea.
42	1" BURNER LESS PILOT BRACKET	150501	3 ea.	4 ea.	6 ea.	9 ea.	11 ea.	14 ea.	16 ea.	18 ea.	21 ea.	24 ea.
43	MANIFOLD (1" BURNERS)	1 ea.	800153	800154	800155	800156	800157	800158	800159	800160	800161	800162
44	NAT GAS ORIFICE (#44 DRILL SIZE)	950300		5 ea.								
44	NAT GAS ORIFICE (#45 DRILL SIZE)	950301			7 ea.							
44	NAT GAS ORIFICE (#47 DRILL SIZE)	950303	4 ea.			10 ea.	12 ea.					
44	NAT GAS ORIFICE (#48 DRILL SIZE)	950304						15 ea.	17 ea.	19 ea.	22 ea.	
44	NAT GAS ORIFICE (#49 DRILL SIZE)	950305										25 ea.
44	LP GAS ORIFICE (#55 DRILL SIZE)	950330		5 ea.	7 ea.							
44	LP GAS ORIFICE (3/64 DRILL SIZE)	950338	4 ea.			10 ea.	12 ea.					
44	LP GAS ORIFICE (#56 DRILL SIZE)	950331						15 ea.				
45	GAS VALVE (STND. PILOT, NAT GAS)	3507010 (VR8200C6008)	1 ea.	1 ea.	1 ea.	1 ea.						
45	GAS VALVE (E.I., NAT GAS)	3507020 (VR8204C6000)	1 ea.	1 ea.	1 ea.	1 ea.						
45	GAS VALVE (STND. PILOT, NAT GAS)	3507110 (VR8300C4134)					1 ea.	1 ea.	1 ea.			
45	GAS VALVE (E.I., NAT GAS)	3507120 (VR8304P4298)					1 ea.	1 ea.	1 ea.	1 ea.	1 ea.	
45	GAS VALVE (STND. PILOT, NAT GAS)**	(V8295A1024)								1 ea.	1 ea.	1 ea.
45	GAS VALVE (STND. PILOT, NAT GAS)** (ROBERTSHAW 7000ERHC-S7C)									1 ea.	1 ea.	1 ea.
45	GAS VALVE (E.I., NAT GAS) (ROBERTSHAW 7000DERHC)											1 ea.
45	GAS VALVE (STND. PILOT, LP GAS)	3507210 (VR8200C6040)	1 ea.	1 ea.	1 ea.	1 ea.						
45	GAS VALVE (E.I. PILOT, LP GAS)	3507220 (VR8204C6018)	1 ea.	1 ea.	1 ea.	1 ea.						
45	GAS VALVE (STND. PILOT, LP GAS)	3507230 (VR8300C4548)					1 ea.	1 ea.				
45	GAS VALVE (E.I., LP GAS)	3507240 (VR8304P4280)					1 ea.	1 ea.				
46	PILOT ASSY. (STND. PILOT, NAT GAS)	3504005 (Q327A1949)	1 ea.	1 ea.	1 ea.	1 ea.	1 ea.	1 ea.	1 ea.	1 ea.	1 ea.	1 ea.
46a	PILOT ASSY. (E.I., NAT GAS)	35-4700 (Q348A1275)	1 ea.	1 ea.	1 ea.	1 ea.	1 ea.	1 ea.	1 ea.	1 ea.	1 ea.	1 ea.
46	PILOT ASSY. (STND. PILOT, LP GAS)	35-4020 (Q327A1915)	1 ea.	1 ea.	1 ea.	1 ea.	1 ea.	1 ea.				
46a	PILOT ASSY. (E.I., LP GAS)	35-4600 (Q348A1259)	1 ea.	1 ea.	1 ea.	1 ea.	1 ea.	1 ea.				
47	THERMOCOUPLE	1 ea.	35-1040	35-1040	35-1040	35-1040	35-1040	35-1040	3501141	3501141	3501141	3501141
47a	IGNITION CABLE	1 ea.	3501124	3501124	3501124	3501130	3501130	3501130	3501136	3501136	3501136	3501136
48	PILOT TUBING	1 ea.	90-042	90-042	90-042	90-043	90-043	90-043	900041	900041	900041	900041
49	1/8 SHORT FERRULE (INCLUDED WITH GAS VALVE)	35-1600 (392449)	1 ea.	1 ea.	1 ea.	1 ea.	1 ea.	1 ea.	1 ea.	1 ea.	1 ea.	1 ea.
50	1/8 LONG FERRULE (INCLUDED WITH PILOT ASSEMBLY)	35-1650 (392449-4)	1 ea.	1 ea.	1 ea.	1 ea.	1 ea.	1 ea.	1 ea.	1 ea.	1 ea.	1 ea.
51	A26 PILOT ORIFICE (STND. PILOT NAT GAS) - INCLUDED WITH PILOT ASSY.		1 ea.	1 ea.	1 ea.	1 ea.	1 ea.	1 ea.	1 ea.	1 ea.	1 ea.	1 ea.
51a	KF24 PILOT ORIFICE (E.I., NAT GAS) - INCLUDED WITH PILOT ASSY.		1 ea.	1 ea.	1 ea.	1 ea.	1 ea.	1 ea.	1 ea.	1 ea.	1 ea.	1 ea.
51	K14 PILOT ORIFICE (STND. PILOT LP GAS) - INCLUDED WITH PILOT ASSY.		1 ea.	1 ea.	1 ea.	1 ea.	1 ea.	1 ea.	1 ea.	1 ea.	1 ea.	1 ea.
51a	K16 PILOT ORIFICE (E.I., LP GAS) - INCLUDED WITH PILOT ASSY.		1 ea.	1 ea.	1 ea.	1 ea.	1 ea.	1 ea.	1 ea.	1 ea.	1 ea.	1 ea.

* NOT PICTURED
** THESE VALVES PIPED IN SERIES TO PROVIDE REDUNDANT SHUT-OFF

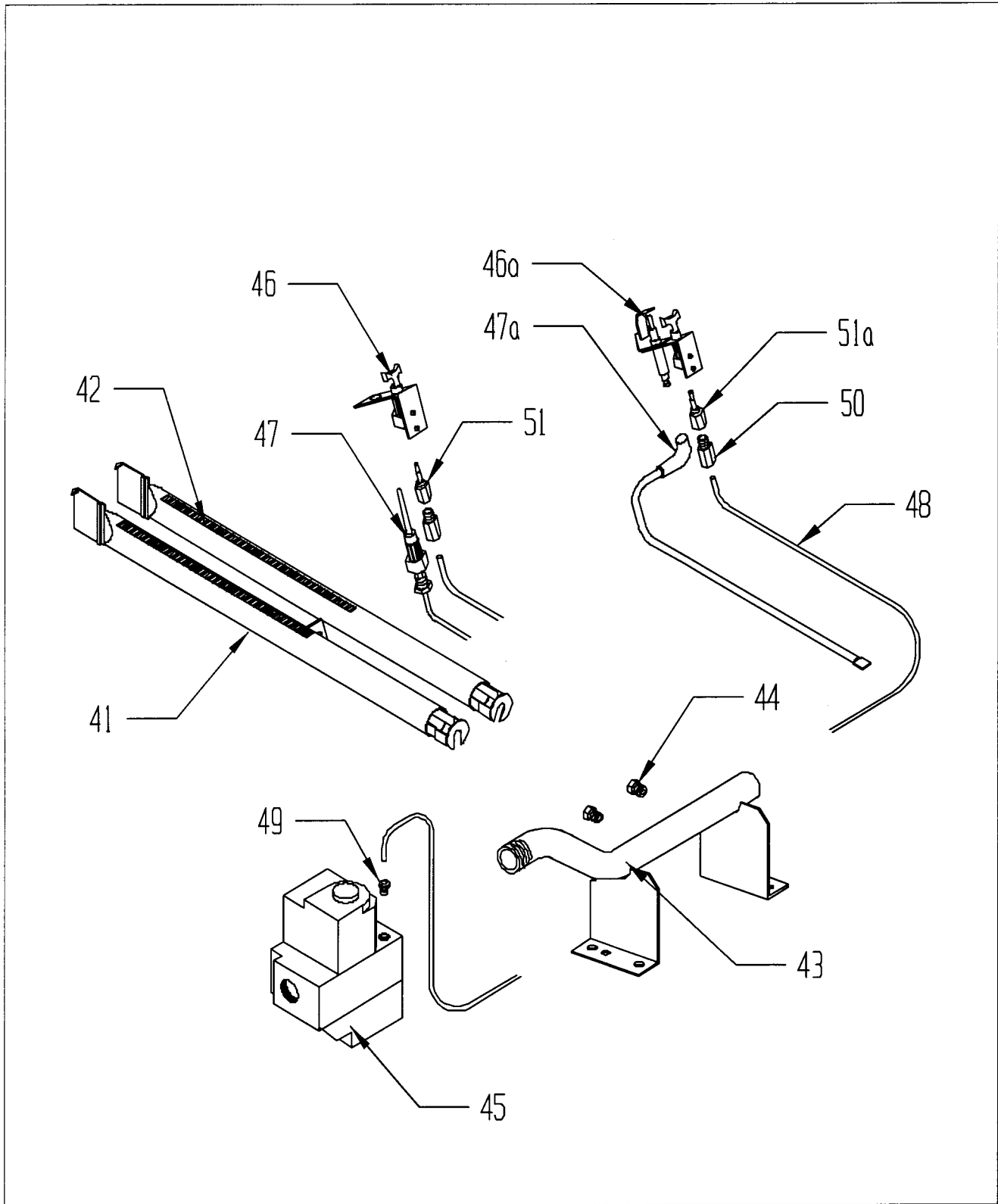

KEY #	DESCRIPTION	QTY. OR CROWN P.N.	QUANTITY PER BOILER OR CROWN P.N.									
			69	103	138	172	207	241	276	310	345	379
75	LEFT SIDE JACKET PANEL	1 ea.	800301	800301	800301	800301	8003015	8003015	8003015	8003015	8003015	8003015
76	RIGHT SIDE JACKET PANEL	1 ea.	800300	800300	800300	800300	8003005	8003005	8003005	8003005	8003005	8003005
77	REAR JACKET PANEL	1 ea.	800303	800304	800305	800306	800307	800308	800309	800310	800311	800312
78	TOP JACKET PANEL	1 ea.	800323	800324	800325	800326	800327	800328	800329	800330	800331	800332
79	LOWER FRONT PANEL (JSI)	1 ea.	800363	800364	800365	800366						
79a	FRONT PANEL (JSE)	1 ea.					800317	800318	800319	800320	800321	800322
80	UPPER FRONT PANEL (JSI)	1 ea.	800353	800354	800355	800356						
81	DIVERter PANEL (JSI)	1 ea.	800373	800374	800375	800376						
82	VESTIBULE PANEL (JSI)	1 ea.	800383	800384	800385	800386						
82a	VESTIBULE PANEL (JSE)	1 ea.					800387	800388	800389	800390	800391	800392
83	HORIZONTAL JACKET CLIP	800340	2 ea.	2 ea.	2 ea.	2 ea.						
84	VERTICAL JACKET CLIP	800341	2 ea.	2 ea.	2 ea.	2 ea.	4 ea.	4 ea.	4 ea.	4 ea.	4 ea.	4 ea.
85	#10 X 1/2" SHEET METAL SCREW	90-212	28 ea.	28 ea.	29 ea.	29 ea.	23 ea.	23 ea.	23 ea.	23 ea.	23 ea.	23 ea.
86	DOOR KNOB	90-210	2 ea.	2 ea.	2 ea.	2 ea.	2 ea.	2 ea.	2 ea.	2 ea.	2 ea.	2 ea.
87	8-32 X 1/4" H.W.H. SCREW	90-211	2 ea.	2 ea.	2 ea.	2 ea.	2 ea.	2 ea.	2 ea.	2 ea.	2 ea.	2 ea.
*	IGNITION MODULE (E.I. BOILERS) (NATURAL GAS ONLY)	35-5000 (S8600F1000)	1 ea.	1 ea.	1 ea.	1 ea.	1 ea.	1 ea.	1 ea.	1 ea.	1 ea.	1 ea.
*	IGNITION MODULE (E.I. BOILERS) (NATURAL OR LP GAS)	35-5050 (S8600M1013)	1 ea.	1 ea.	1 ea.	1 ea.	1 ea.	1 ea.				
*	MODULE BRACKET (E.I. BOILERS)	905000	1 ea.	1 ea.	1 ea.	1 ea.	1 ea.	1 ea.	1 ea.	1 ea.	1 ea.	1 ea.
88	VENT DAMPER	1 ea.	96-030	96-031	96-032	96-032	96-033	96-033	96-035	96-035	96-035	96-035
89	GLASS SET	950077	1 ea.	1 ea.	1 ea.	1 ea.	1 ea.	1 ea.	1 ea.	1 ea.	1 ea.	1 ea.
90	FLOAT TYPE L.W.C.O. (#67 CR-2)	400676	1 ea.	1 ea.	1 ea.	1 ea.	1 ea.	1 ea.	1 ea.	1 ea.	1 ea.	1 ea.
90a	PROBE TYPE L.W.C.O. (CG400)	400821	1 ea.	1 ea.	1 ea.	1 ea.	1 ea.	1 ea.	1 ea.	1 ea.	1 ea.	1 ea.
91	PRESSURE GUAGE	95-070	1 ea.	1 ea.	1 ea.	1 ea.	1 ea.	1 ea.	1 ea.	1 ea.	1 ea.	1 ea.
92	3/4" SAFETY VALVE (15 psi)	95-079	1 ea.	1 ea.	1 ea.	1 ea.	1 ea.	1 ea.	1 ea.	1 ea.	1 ea.	1 ea.
93	90 DEGREE PIG-TAIL	95-060B	1 ea.	1 ea.	1 ea.	1 ea.	1 ea.	1 ea.	1 ea.	1 ea.	1 ea.	1 ea.
94	PRESSURE LIMIT (PA404A1009)	35-5020	1 ea.	1 ea.	1 ea.	1 ea.	1 ea.	1 ea.	1 ea.	1 ea.	1 ea.	1 ea.
95	3/4" BOILER DRAIN	95-041	1 ea.	1 ea.	1 ea.	1 ea.	1 ea.	1 ea.	1 ea.	1 ea.	1 ea.	1 ea.
96	JUNCTION BOX	960155	1 ea.	1 ea.	1 ea.	1 ea.	1 ea.	1 ea.	1 ea.	1 ea.	1 ea.	1 ea.
97	TRANSFORMER MOUNTING PLATE	960156	1 ea.	1 ea.	1 ea.	1 ea.	1 ea.	1 ea.	1 ea.	1 ea.	1 ea.	1 ea.
98	24V TRANSFORMER (AT140D1012)	3502300	1 ea.	1 ea.	1 ea.	1 ea.	1 ea.	1 ea.	1 ea.	1 ea.	1 ea.	1 ea.
99	8-32 X 1/2" SELF TAPPING SCREW	90-223	4 ea.	4 ea.	4 ea.	4 ea.	4 ea.	4 ea.	4 ea.	4 ea.	4 ea.	4 ea.
100	SPST RELAY (R8225B1049)	3505540	1 ea.	1 ea.	1 ea.	1 ea.	1 ea.	1 ea.	1 ea.	1 ea.	1 ea.	1 ea.
*	DAMPER WIRE HARNESS	1 ea.	9601300	9601300	9601300	9601300	9601350	9601350	9601350	9601350	9601350	9601350
*	SPILL SWITCH HARNESS	1 ea.	9601270	9601270	9601270	9601270	9601275	9601275	9601275	9601275	9601275	9601275
*	J-BOX - R.O. SWITCH HARNESS	9601280	1 ea.	1 ea.	1 ea.	1 ea.	1 ea.	1 ea.	1 ea.	1 ea.	1 ea.	1 ea.
*	#67 L.W.C.O. - J-BOX HARNESS	9601367	1 ea.	1 ea.	1 ea.	1 ea.	1 ea.	1 ea.	1 ea.	1 ea.	1 ea.	1 ea.
*	CG400 L.W.C.O. - J-BOX HARNESS	9601400	1 ea.	1 ea.	1 ea.	1 ea.	1 ea.	1 ea.	1 ea.	1 ea.	1 ea.	1 ea.
*	PRESSURE LIMIT - J-BOX HARNESS	9601210	1 ea.	1 ea.	1 ea.	1 ea.	1 ea.	1 ea.	1 ea.	1 ea.	1 ea.	1 ea.
*	INTERMITTENT IGNITION HARNESS	9601100	1 ea.	1 ea.	1 ea.	1 ea.	1 ea.	1 ea.	1 ea.	1 ea.	1 ea.	1 ea.

* NOT PICTURED

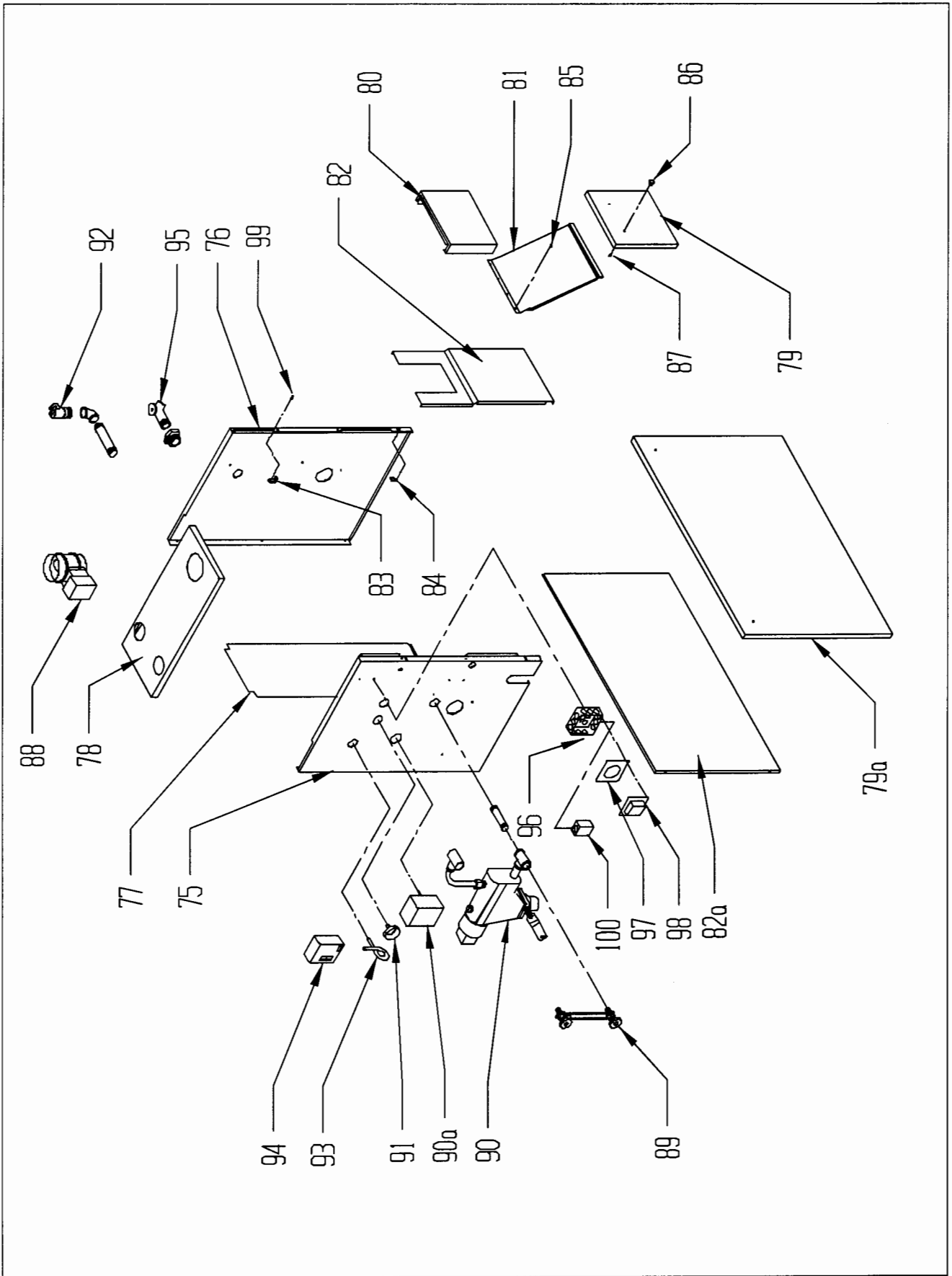

CROWN Boiler Co.

Manufacturer of Hydronic Heatings Products

P.O. Box 14818 3633 I. Street

Philadelphia, PA 19134

Tel: (215) 535-8900 • Fax: (215) 535-9736 • www.crownboiler.com

Free Manuals Download Website

<http://myh66.com>

<http://usermanuals.us>

<http://www.somanuals.com>

<http://www.4manuals.cc>

<http://www.manual-lib.com>

<http://www.404manual.com>

<http://www.luxmanual.com>

<http://aubethermostatmanual.com>

Golf course search by state

<http://golfingnear.com>

Email search by domain

<http://emailbydomain.com>

Auto manuals search

<http://auto.somanuals.com>

TV manuals search

<http://tv.somanuals.com>