

CROWN

Specifications

SH 5500 Series

Heavy-Duty Walkie
Straddle Stacker

SH 5500

Series



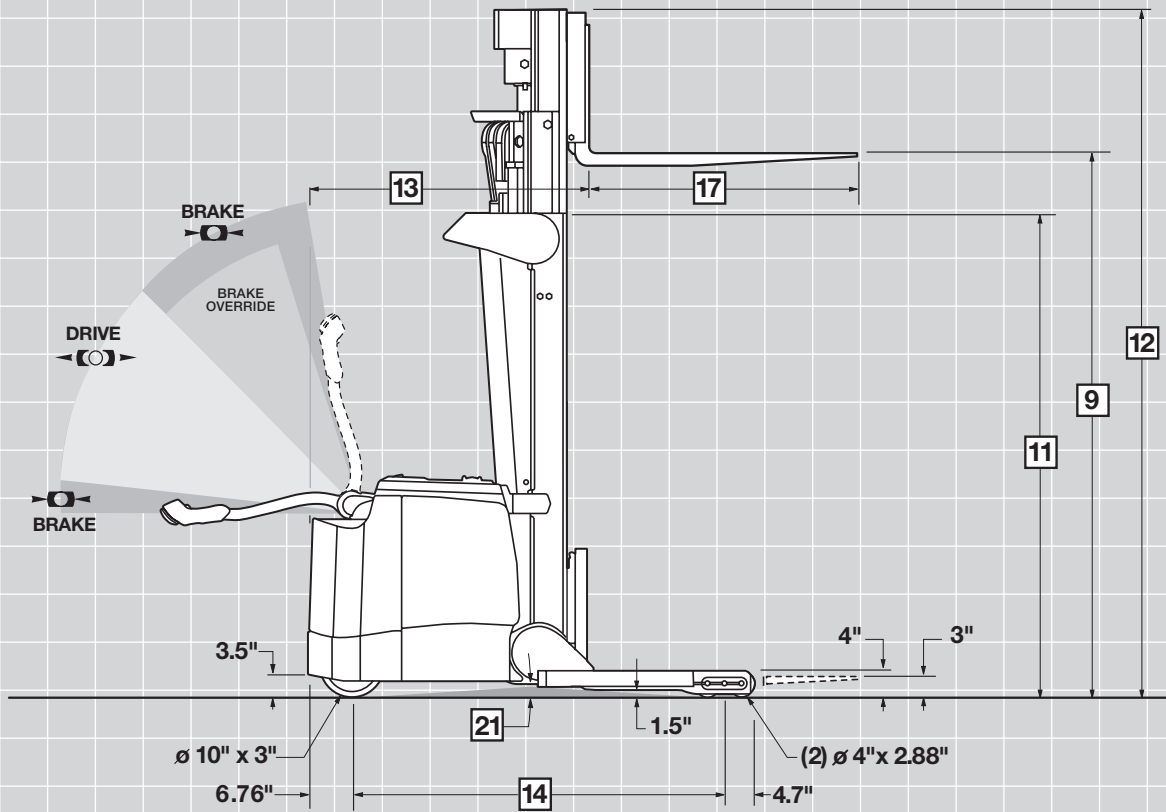
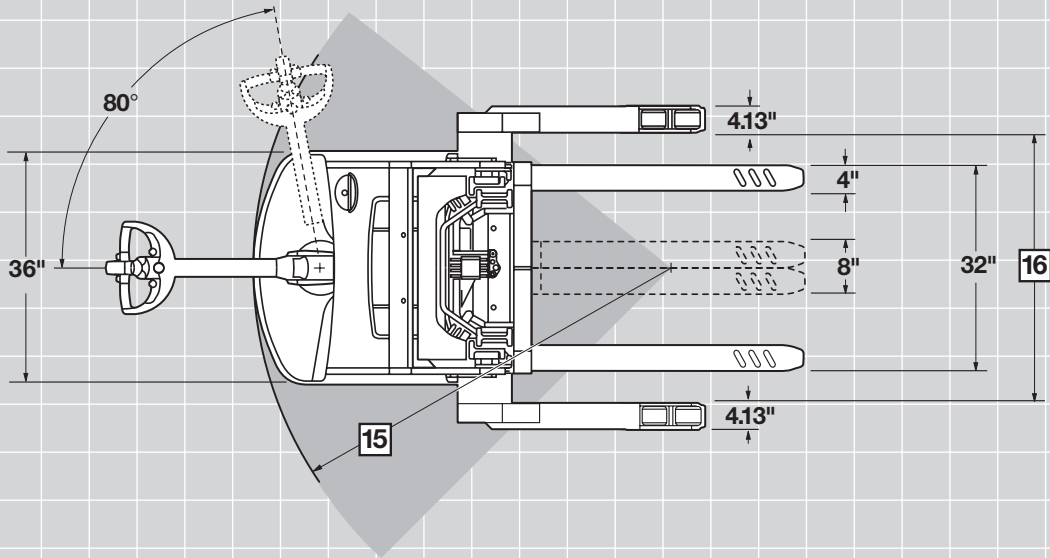

General Information	1	Manufacturer	Crown Equipment Corporation		
	2	Model	SH 5520-40		SH 5540-40
	3	Load Capacity	lb	See Chart	See Chart
	4	Load Center	in	24	24
	5	Power	Electric	24 Volts	24 Volts
	6	Operator Type	Walkie	Stacker	Stacker
	7	Tire Type	Load/Drive	Poly/Vulkolan	Poly/Vulkolan
	8	Wheels (x=driven)	Load/Drive	4/1x	4/1x
Dimensions	9	Lifting Height	in	See Chart	See Chart
	13	Head Length*	in	36.8	43.3
	14	Wheelbase	in	51.4	57.9
	15	Turning Radius	in	60.9	67.4
	16	Inside Straddle	in	34 - 50 inches in 2" increments	
17	Forks	Standard LxWxT	in	36 x 4 x 1.75	
		Optional Lengths	in	30, 39, 42, 45, 48, 54, 60	
Performance	18	Travel Speeds	Empty/Loaded	mph	3.7 / 3.4
	19	Lift Speeds	Empty/Loaded	fpm	48.4 / 29.5
	20	Lowering Speeds	Empty/Loaded	fpm	50 / 50
	21	Grade Clearance	%	9	8
	22	Battery	Min Weight/Max Amp		510 / 300
Max Battery Size WxLxH				6.62 x 34.37 x 24.8	13.12 x 31.10 x 24.8

* Add 2.1" for Side Shift

Mast and Weight	Mast Type		TL - Limited Free Lift		TT - Triple Telescopic			
	9	Lifting Height	in	127.5	150.5	156	192	
	3	Load Capacity	SH 5520-40	lb	4000	4000	4000	na
			SH 5540-40	lb	4000	4000	4000	3000
	10	Free Lift w/o LBR	in	6	6	52.6	52.6	
	11	Collapsed Height	in	83.5	95.5	75	89	
	12	Extended Height**	in	150	173	178.5	214.5	
	23	Min ID Straddle Width	in	34	34	38	42	
24	Truck Weight w/o Battery***	SH 5520-40	lb	3025	3130	3570	na	
		SH 5540-40	lb	2840	2945	3385	3620	

** Add 24.7" with Load Backrest

*** Add 85 lb for Load Backrest
Add 120 lb for Side Shift

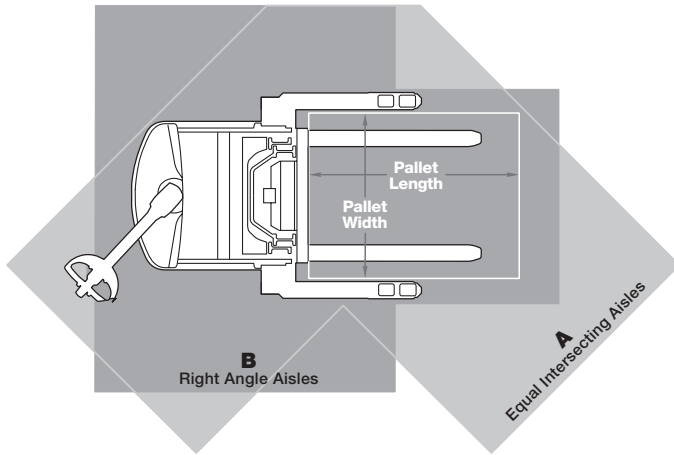

SH 5520

Pallet Width		Pallet Length									
		30		36		40		42		48	
		A	B	A	B	A	B	A	B	A	B
36	in	65	68	65	68	65	68	65	68	68	79
40	in	68	69	68	69	68	69	68	69	68	79
42	in	69	70	69	70	69	70	69	70	69	73
48	in	73	71	73	71	73	71	73	71	73	71

SH 5540

Pallet Width		Pallet Length									
		30		36		40		42		48	
		A	B	A	B	A	B	A	B	A	B
36	in	65	74	65	74	65	74	65	73	67	82
40	in	67	75	67	75	67	75	67	75	67	78
42	in	68	75	68	75	68	75	68	75	68	75
48	in	71	77	71	77	71	77	71	77	71	77

A = Equal Intersecting Aisles
 B = Right Angle Aisles

Add 2.5" if side shift option is used.
 Add 6" to 12" to all aisle dimensions for maximum maneuverability.

Capacity

4000 lb at 24" load center

Maximum Battery Size

SH 5520-40: 6.62" wide x 34.37" long x 24.8" high – up to 300 amp hours, 24 volts

SH 5540-40: 13.12" wide x 31.10" long x 24.8" high – up to 660 amp hours, 24 volts

Standard Equipment

- 24-volt electrical system
- Crown's Access 1 2 3® Comprehensive System Control
- Access 1 2 3 display
 - Eight-character scrolling display, 5 button access
 - Three selectable performance levels
 - BDI with lift interrupt
 - Five hour meters
 - Event codes
 - Access 1 2 3 diagnostics with real time troubleshooting
 - PIN code capability
- AC traction and steer motors

- Performance enhancing features
 - X10® Handle
 - Brake override
 - Electronic power steering
 - Ramp hold and speed control
 - Power boost
 - High-visibility mast and carriage
 - Low profile power unit
 - Tool storage tray
- Wire mesh guard - mast
- Volkollan drive tire – 10" dia. x 3" wide
- Polyurethane load wheels – 4" dia. x 2.88" wide
- InfoPoint® System
- Steel power unit covers
- Emergency power disconnect
- Key switch
- Horn
- SB175 gray battery connector
- Reversing button
- Electric park brake
- Fork tip indicators
- Battery compartment rollers

Optional Equipment

- 30 amp on-board charger (6.62" battery box)
- Keyless on-off switch
- Work Assist™ Accessories:
 - Clip pad
 - Hook
 - Clip pad and hook
 - Pocket
 - Fan
- Sideshift with internal hosing
- 47" tall load backrest
- Optional fork lengths (30", 39", 42", 45", 48", 54", 60")
- Freezer conditioning (Continuous -30° C / -22° F)
- Plexiglass safety shield
- 10" dia. x 4" wide drive tire
 - Soft poly
 - Siped soft poly
- InfoLink® ready
- SBE 160 battery connector

SH 5500 Series Technical Information

Operator Controls

Crown's robust X10 handle places all control buttons in the optimum position for ease of operation with either hand and to minimize hand and wrist movements. An ergonomic forward/reverse thumb wheel allows for precise maneuvering. The control hand grips are urethane covered for insulation from cold and vibration with integrated horn buttons for easy activation. The handle contains a safety button which reverses the direction of the truck should the button touch the operator.

The physical efforts to hold the handle at a comfortable height was minimized to reduce fatigue.

A rabbit/turtle switch incorporates two levels of programmable travel performance so operators can select the setting that matches their experience level or application requirements.

Exclusive brake override feature allows slow speed travel with the handle near vertical. This feature improves maneuverability in tight areas.

Performance

The SH 5500 Series incorporates the latest generation AC drive system enhanced with Access 1 2 3 technology. Crown's Access 1 2 3 technology continuously monitors truck systems and adjusts system parameters to deliver optimum performance and control. The Access Display provides a convenient interface for operators keeping them informed of any changes impacting truck performance and allowing them to choose from three performance profiles when enabled.

Programmable performance settings enable authorized personnel to tune the lift truck to different operator skill levels, or to meet specific application requirements. In addition, up to 25 PIN codes can be assigned to individual operators and matched to one of the pre-programmed performance profiles if desired.

Electronic power steering allows the operator to maneuver heavy loads in tight spaces throughout the day while minimizing fatigue. Smooth travel and lift performance combine with excellent controls provided by the X10 handle to increase productivity.

The SH 5500 Series features ramp hold and speed control to improve operation on small inclines or ramps. The ramp hold feature uses the motor to prevent truck movement when the brake is released and no travel command is present. The ramp speed control feature insures that actual travel speed matches requested travel speed. If the truck encounters an obstacle, a power boost feature delivers up to 15 percent more power than normally available for a full three seconds to overcome the obstruction.

Electrical System

A heavy-duty 24-volt fused electrical system utilizes microprocessor controls for maximum energy efficiency, reduced maintenance and infinite speed control capability.

Access control modules for travel, lift and steer are sealed from dirt, dust and moisture for trouble-free operation. All contactors have been eliminated except for the main line contactor. A 175 amp battery connector with disconnect handle is standard.

Hydraulic System

Heavy-duty hydraulic motor (4.8 kw) is transistor controlled and matched with a gear type pump selected for optimum lift performance and low noise. Single-speed lift with programmable acceleration - deceleration and programmable two-speed lowering enables customization to match operator preference or application requirements.

Cylinder rods are hard-plated chrome with polyurethane seals. Relief valve tuned to capacity protects all components in the hydraulic system. Reservoir incorporates an in-tank 10 micron return filter for removing debris from oil.

Drive Unit / Brake

Heavy-duty gearbox with helical spur input gear for quiet operation.

Regenerative motor braking is activated under a downhill condition, during plugging or when the directional control is returned to neutral. An electro-magnetic brake, spring applied and electrically released, is mounted on top of the drive motor. The electro-magnetic brake serves as the parking brake and applies when the control handle position moves from the operating zone to brake zone during truck operation.

Power Steering

Electronic power steering is provided by a heavy-duty AC motor that pivots the drive unit when steer tiller movement is detected.

Mast

High visibility two and three-stage mast design with angled cross bracing and lift cylinders located behind nested I-beams provides maximum visibility for load positioning and placement. Crown's staging cushions coupled with lowering dampers ensure smooth operation.

Roller steel outer mast channels and inner I-beams roll on canted, steel, anti-friction roller bearings for minimal current draw and long life. Mast and chain rollers are sealed and lubricated for life. Telescoping mast sections nest to reduce truck length. Heavier mast cross bracing design increases stiffness.

Serviceability / Durability

The Access display simplifies service for technicians by providing advanced diagnostics without the need for separate handsets. The display allows the technician to view event service codes and truck hours when event occurred, perform system calibrations or functional tests of components, and make necessary adjustments. Crown's InfoPoint System compliments Access 1 2 3 diagnostics by providing a Quick Reference Guide, on-truck component maps and information nuggets to further simplify troubleshooting. All wiring is color coded.

Removable steel power unit doors are hinged for ease of opening providing excellent accessibility to the distribution panel and all other components. Steel covers provide added protection to critical internal components.

Removable steel battery covers and hinged cover allow easy access to the battery. Battery removal can be accomplished from either side. Battery compartment rollers are standard.

The X10 handle incorporates a vacuum die cast process using high-grade aluminum and benefits from structural webbing for maximum strength and durability.

Other Options

1. Amber strobe light
2. Travel alarm: reverse, forward or both

Safety considerations and dangers associated with audible travel alarms and strobe lights include:

- Multiple alarms and/or lights can cause confusion.
- Workers ignore the alarms and/or lights after day-in and day-out exposure.
- Operator may transfer the responsibility for "looking out" to the pedestrians.
- Annoys operators and pedestrians.

Dimensions and performance data given may vary due to manufacturing tolerances. Performance is based on an average size vehicle and is affected by weight, condition of truck, how it is equipped and the conditions of the operating area. Crown products and specifications are subject to change without notice.



Crown Equipment Corporation
New Bremen, Ohio 45869 USA
Tel 419-629-2311
Fax 419-629-3796
crown.com

You can count on Crown to build lift trucks designed for safe operation, but that's only part of the safety equation. Crown encourages safe operating practices through ongoing operator training, safety-focused supervision, maintenance and a safe working environment. Go to crown.com and view our safety section to learn more.

Because Crown is continually improving its products, specifications are subject to change without notice.

Crown, the Crown logo, the color beige, the Momentum symbol, Access 1 2 3, InfoPoint, InfoLink and X10 Handle are trademarks of Crown Equipment Corporation.

Copyright 2008 Crown Equipment Corporation
SF14905 1/08
Printed in U.S.A.

Free Manuals Download Website

<http://myh66.com>

<http://usermanuals.us>

<http://www.somanuals.com>

<http://www.4manuals.cc>

<http://www.manual-lib.com>

<http://www.404manual.com>

<http://www.luxmanual.com>

<http://aubethermostatmanual.com>

Golf course search by state

<http://golfingnear.com>

Email search by domain

<http://emailbydomain.com>

Auto manuals search

<http://auto.somanuals.com>

TV manuals search

<http://tv.somanuals.com>