

CROWN

Specifications

SP 3500 Series

Stockpicker

SP 3500

Series



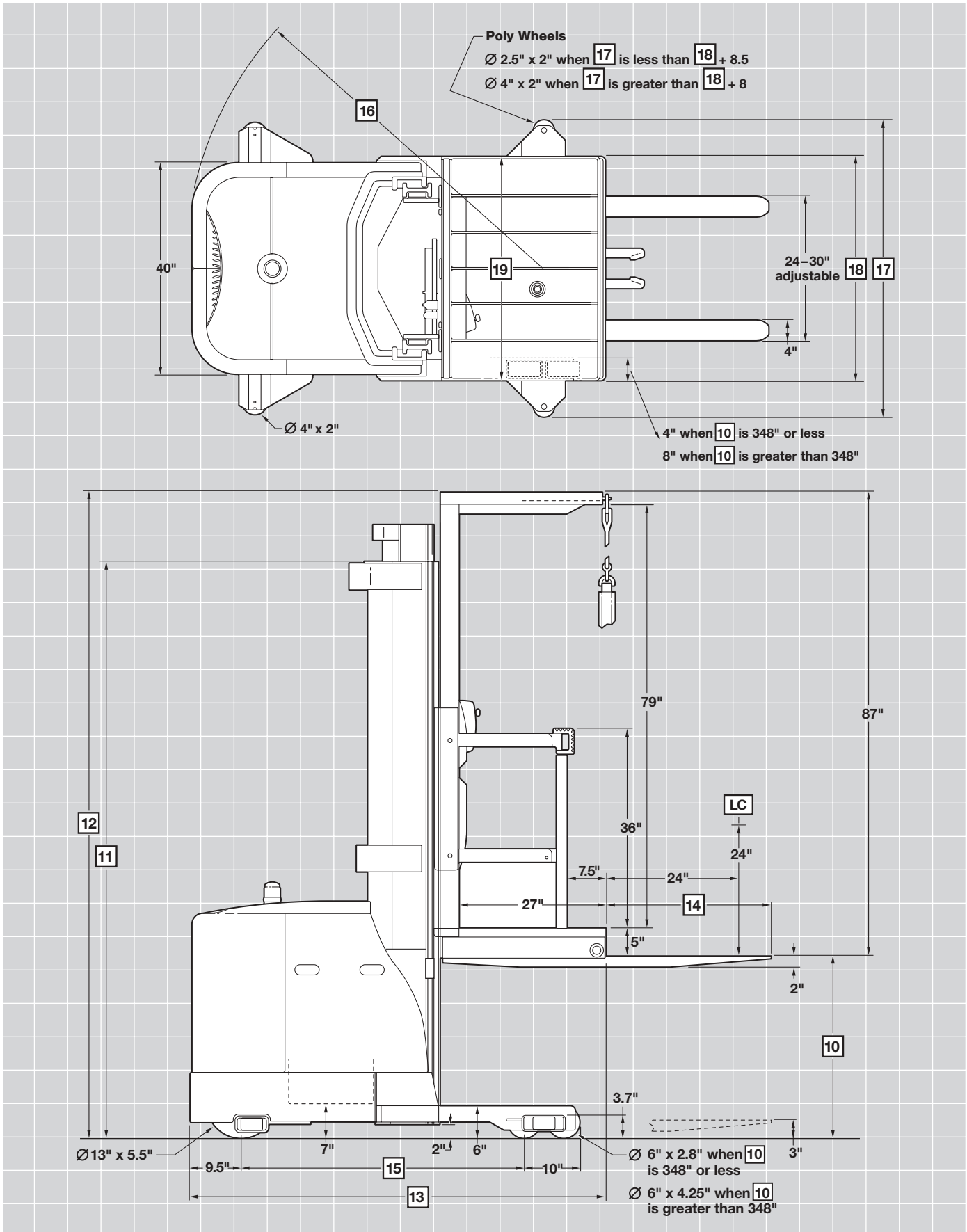

General Information	1	Manufacturer		Crown Equipment Corporation	Crown Equipment Corporation		
	2	Model		SP 3505-30	SP 3510-30		
	3	Load Capacity*	lb	See Chart	See Chart		
	4	Load Center	Platform face to load CG	in	24	24	
	5	Power	Electric	Volts	24	24	
	6	Operator Type	Stand-up Rider		Stockpicker	Stockpicker	
	7	Tire Type	Load/Drive		Poly/Poly	Poly/Poly	
	8	Wheels (x = driven)	Load/Drive		4/1x	4/1x	
Dimensions	10	Lifting Height		in	See Chart	See Chart	
	13	Head Length	TL/TT	in	74.6/75.6	74.6/75.6	
	14	Forks	Standard	L x W x T	in	36 x 4 x 2	36 x 4 x 2
			Optional Lengths		in	30, 39, 42, 45, 48, 54, 60, 72, 84	30, 39, 42, 45, 48, 54, 60, 72, 84
	15	Wheelbase	TL/TT		in	52/51	52/51
16	Turning Radius	TL/TT		in	69/68	69/68	
Performance	20	Speed Travel		Empty/Loaded	mph	See Chart	See Chart
	21	Speed Lift	TL	Empty/Loaded	fpm	45/28	45/28
			TT	Empty/Loaded	fpm	40/26	40/26
	22	Speed Lower	TL	Empty/Loaded	fpm	40/38 Low, 80/75 High	40/38 Low, 80/75 High
TT			Empty/Loaded	fpm	40/38 Low, 80/75 High	40/38 Low, 80/75 High	
Battery	23	Battery	Type			Lead Acid	Lead Acid
			Min Weight/Max Amp			975/660	1520/1085
			Max Battery Size			13.12 x 31.75 x 23.25 High	14.25 x 36.25 x 31 High

* Contact factory. Capacity may be subject to derating, depending upon lifting height, load center and fork length.

				TL					
Capacity	10	Lifting Height	in	136	148	172	194	214	
	3	Load Capacity	SP 3505	lb	3000	3000	3000	3000	3000
			SP 3510	lb	3000	3000	3000	3000	3000
			SP 3520	lb	3000	3000	3000	3000	3000
SP 3550H			lb	na	na	na	na	na	
Mast		Free Lift	in	3	6	6	6	6	
	11	Collapsed Height	in	89.5	95	107	119	131	
	12	Extended Height	in	223	235	259	281	301	
	18	Straddle Width	in	42	42	42	42	42	
	19	Operator Compartment Width	in	42	42	42	42	42	
	17	Aisle Guide Wheel Range†	in	45.50 to 65.25	45.50 to 65.25	45.50 to 65.25	45.50 to 65.25	45.50 to 65.25	
Truck Weight		Truck Weight Without Battery	SP 3505	lb	5027	5086	5216	5504	5634
			SP 3510	lb	5027	5086	5216	5504	5634
			SP 3520	lb	5088	5147	5277	5565	5695
			SP 3550H	lb	na	na	na	na	na

† In .25" increments.

†† 48" straddle width on SP 3405 only.

SP 3500 Series

Specifications

Crown Equipment Corporation	Crown Equipment Corporation
SP 3520-30	SP 3550H-30
See Chart	See Chart
24	24
24	24
Stockpicker	Stockpicker
Poly/Poly	Poly/Poly
4/1x	4/1x
See Chart	See Chart
74.6/75.6	na/75.6
36 x 4 x 2	36 x 4 x 2
30, 39, 42, 45, 48, 54, 60, 72, 84	30, 39, 42, 45, 48, 54, 60, 72, 84
52/51	na/51
69/68	na/68
See Chart	See Chart
45/28 Low, 80/46 High	na
40/26 Low, 71/43 High	40/26 Low, 71/43 High
40/38 Low, 80/75 High	na
40/38 Low, 80/75 High	40/38 Low, 80/75 High
Lead Acid	Lead Acid
1520/1085	1520/1085
14.25 x 36.25 x 31 High	14.25 x 36.25 x 31 High

Lift Height (inches)	Steered Wheel < 10° ⁽¹⁾		
	Power Unit First (PUF) ⁽²⁾		
	Travel Speed (mph) Empty/Loaded		
	SP 3505	SP 3510 SP 3520	SP 3550H
0-24	6.5	7.5	7.5
24-64	6.5-5.5	7.5-6.0	7.5-6.5
64-120	5.5-3.3	6.0-3.8	6.5-4.5
120-152	3.3-2.1	3.8-2.7	4.5-3.4
152-176	2.1-1.2	2.7-2.0	3.4-2.6
176-192	1.2	2.0-1.5	2.6-2.2
192-216	1.2	1.5	2.2-1.5
216-max	1.2	1.5	1.5

⁽¹⁾ Top travel speed is reduced to 80% at a 10° steering angle, beyond 10° travel speeds gradually reduce down to 50% of top travel speed. Steering angle is automatically limited to within 10° straight travel as indicated below:

- SP 3505 above 176"
- SP 3510 and SP 3520 above 192"
- SP 3550H above 216"

⁽²⁾ From 0-60 inches, travel speeds in the Forks First (FF) direction of travel are approximately .5 mph less than travel speeds in the Power Unit First (PUF) direction.

TT								
195	210	240	276	294	312	330	348	366
3000	3000	3000	na	na	na	na	na	na
3000	3000	3000	na	na	na	na	na	na
3000	3000	3000	2000	1750	1500	na	na	na
na	na	na	2500	2350	2200	2050	1900	1750
3	8	20	32	38	44	56	62	68
89.5	95	107	119	125	131	143	149	155
283	298	328	364	382	400	418	436	454
42	42	42††	48	54	54	56	60	60
42	42	42	48	54	54	54	60	60
45.50 to 65.25	45.50 to 65.25	45.50 to 65.25	48.75 to 71.25	54.75 to 77.25	54.75 to 77.25	56.75 to 79.25	60.75 to 83.25	60.75 to 83.25
5601	5686	6200	na	na	na	na	na	na
5601	5686	5872	na	na	na	na	na	na
5662	5747	5933	6354	6536	6629	na	na	na
na	na	na	6444	6626	6718	6914	7060	7490

Standard Equipment

1. Crown's Access 1 2 3® Comprehensive System Control
2. Crown's AC traction control system
3. 24-volt electrical system
4. Electronic steering
5. Linear Height Speed Control
6. High-speed lift (SP 3520 and SP 3550H)
7. Two-speed lower with soft start and stop
8. Programmable lift/lower cut outs
9. Intelligent Braking System (IBS) with low-profile brake pedal
10. Crown Display
 - Battery discharge indicator with lift interrupt
 - Hour meters/travel distance/stop watch
 - PIN code access capable
 - Access 1 2 3 diagnostics
 - P1, P2, P3 Performance
 - Standard steer tire direction indicator (non wire-guided trucks)
 - Enhanced steer tire direction indicator (wire-guided trucks)
11. Lift motor brush wear and overtemp indicator (SP 3550H).
12. Soft urethane twist grip with "cam grip"
13. 10° angled steer wheel with soft feel spinner
14. Storage compartment
15. Premium platform cushion
16. Clear visibility platform window
17. Clear visibility mast design
18. Key switch
19. Horn
20. Strobe light, amber
21. Hinged side gates with power disconnect
22. 14.25" battery compartment (13.12" on SP 3505)
23. 350 amp battery connector (175 amp on SP 3505)
24. 2" diameter battery compartment rollers
25. Top battery access for service
26. Removable steel battery side covers
27. Adjustable battery retainer
28. Hinged, lift off steel power unit doors
29. Emergency power cut-out
30. Operator belt and lanyard

31. Pallet clamp
32. InfoPoint® Quick Reference Guide and Maps
33. Color-coded wiring
34. 6" diameter tandem load wheels

Optional Equipment

1. Crown wire guidance (broadband technology) operates on all frequencies ranging from 5.2 through 10 KHz without changing components.
2. End of Aisle Control System (wire or rail guidance required)
3. Aisle guide wheels for rail guidance
4. Lift motor brush wear and overtemp indicator (SP 3520).
5. Enhanced steer tire direction indicator (non-wire guided trucks)
6. Battery retainer interlock switch
7. Work lights, dome light and two-speed fan
8. Spotlights
9. Flashing light, amber
10. Programmable lift/lower cutouts with over-rides.
11. Zone select key switch
12. 48", 54", and 60" wide operator platforms
13. Corrosion conditioning
14. Freezer conditioning (Includes corrosion conditioning, ribbed floor mat, and wire mesh windshield)
15. EE Rating available on SP 3520 and SP 3550H
16. Wire mesh screen (Standard with freezer conditioning)
17. Retractable tether
18. Load wheel and drive tire compounds
19. 30" lanyard boom
20. InfoLink™ Ready
21. Positive / negative accessory cable
22. Special paint
 - Clip pad and hook
 - Plate
 - Pocket
24. Fire extinguisher

Operator Platform

The operator area is designed for maximum visibility and stability for increased operator confidence and comfort.

The operator platform features a large window (1088 sq in) for excellent visibility. A Crown-designed clear-visibility mast affords the platform window one forward and two peripheral windows for maximum visibility, even when the platform is lowered.

The clear-visibility mast, with full free lift, extends the platform window above the mast channels for unobstructed visibility when raised.

A low-profile power unit, low placement of the lower cross brace and an outer C-channel rail assembly also contribute to excellent visibility.

A soft urethane twist grip is solidly mounted to the truck console to provide excellent stability for the operator during travel, plugging and braking. Controls for lift/lower, horn and emergency disconnect are conveniently located for efficient operation and minimal operator fatigue. The steering wheel is angled at 10° and recessed to maximize the work area and reduce steer effort. The steering wheel and spinner knob are covered with soft urethane to reduce grip force and insulate against vibration. Control location keeps the operator's posture neutral at all times.

The platform cushion, made of a microcellular composition, absorbs shock and vibration. The brake pedal has a low-profile design and when engaged is flush with the platform cushion for maximum comfort. Heavy-duty side gates, with two horizontal and one vertical support rails, communicate security to the operator. For additional safety, cut-out switches disengage truck operation when side gates are raised.

Two work lights, two dome lights and a two-speed fan are optional. "Power-on" key prevents unauthorized operation of the truck. The Access 1 2 3 Display Panel provides concise, clear feedback for the operator during truck operation.

Crown's Access 1 2 3...

The Comprehensive Access 1 2 3 System Control is a modular based communications and control system. It monitors all on-board sensors, makes decisions based on the sensor readings, and subsequently, controls all system movements safely and smoothly. All five modules are in constant communications with each other via a CAN (Control Area Network) bus so that real information is accessible to the system at all times.

- Interactive Display Module
- Traction Control Module
- Vehicle Control Module
- Steering Control Module
- Guidance Control Module

Crown Drive System

Crown has applied the latest generation AC drive system, enhanced with Access 1 2 3 technology. A Crown-manufactured drive unit uses spiral bevel and helical gears from motor to drive wheel axle.

Fixed, mounted drive motor does not rotate minimizing wear on electrical cables. Drive tire changing is simplified with this drive unit.

Crown's AC Drive system dramatically improves travel speeds, acceleration and deceleration, thus increasing productivity.

The standard linear speed control provides smooth travel speed transition as lift heights change and increases productivity.

Travel System

Truck performance specifications (maximum travel speed, coast, plugging, acceleration, travel speed at height, and low speed lowering) are adjustable using Access 1 2 3. This enables customizing truck performance to meet specific application or operator requirements.

Crown's InfoPoint system offers evolutionary refinement for service simplicity. The InfoPoint Quick Reference Guide, on-truck component maps and information nuggets located throughout the truck allow technicians to troubleshoot without schematics, wiring diagrams, or service manuals for more than 95 percent of repairs.

The InfoPoint Quick Reference Guide provides code definition and overall component ID so the technician knows what it is, where it is, and what it does (Three W's). InfoPoint ensures faster, simpler, and higher quality service.

Intelligent Steering

Standard on the SP 3500 Series is electronic steering that is microprocessor based.

Crown's intelligent steering feature slows the truck automatically when the steer wheel is turned beyond 10°. Access 1 2 3 monitors the height of the operator platform, truck speed and steer wheel position.

Steering wheel rotation provides smooth, operator feedback. Steer effort is minimal, lock to lock revolutions is 4.5 turns. Drive wheel rotates a full 180° for maximum maneuverability. Auto centering drive tire for trucks equipped with rail guidance. Steering is connected to the Control System for full diagnostics and operator interface.

Intelligent Braking System (IBS)

Crown's patented Intelligent Braking System combines motor braking with optimum amounts of friction braking (three varying levels of force). The appropriate level of braking is applied dependent upon platform height, direction of travel, and truck weight. Braking force is automatically reduced as height increases and speed decreases. Optimum braking for the right elevation gives operators more confidence and better control, while eliminating abrupt stops and reducing platform sway. Brake lining life can be expected to last up to twice as long before replacement is necessary.

Braking can also be accomplished by proportional plugging, which permits the operator to control the rate of deceleration when extended stopping distance is preferred.

Simplified Hydraulics

Heavy-duty series wound pump motors and gear pumps are assembled into an integral unit. High-speed lift is standard on SP 3520 and SP 3550H models. Crown-manufactured solenoid type manifolds with built-in checks and relief valves.

Two-speed lowering (high/low) with soft start is standard on all models. Low speed lowering is adjustable with the use of the Access 1 2 3 Display. Soft-start lowering feature reduces the harshness at the beginning and end of the lowering cycle. The softer start is accomplished by controlling how quickly the proportional valve is opened or closed. Valve actuation is controlled by a driver in the steering control module.

Maximum lowering speed is regulated by a pressure

compensating flow control valve. Velocity fuses are used in all cylinders to stop lowering should lowering speed exceed a preset value due to a line rupture. A hydraulic accumulator is used to cushion raise and lower functions. Manual lowering control on manifold block allows lowering of platform from ground level. Oil reservoir is designed with a 100 mesh screen at the fill location, a suction strainer, spin-on type 10 micron return line filter and a magnetic drain plug.

The Crown Mast Assembly

High visibility two- and three-stage masts feature nested rail design with lift cylinders positioned behind mast rails. Three-stage mast has a low center position cylinder for free lift. Routing of hosing and cables optimizes visibility through mast. Built-in sensors detect chain slack and shut down primary lower function. Exclusive spring-loaded staging bumpers virtually eliminate platform impact as platform stages. Negative rail drop allows shimming of mast rollers without major disassembly.

Stronger Low Profile Power Unit

Power unit is fabricated from heavy-gauge steel. Lower skirt is .75" steel that runs 9" high for component protection. Rugged steel doors suspended on heavy-duty pin hinges cover power unit componentry. Doors swing wide for open access. Doors can also be lifted off for unrestricted service access. Door bolts have exclusive convex design that mates with concave door holes for fast reinstallation of door bolts. Battery side covers are all steel. An optional battery retainer interlock switch is available. Top battery access is available by lifting cover. Cover has integral support post.

Wheels and Tires

Polyurethane drive tire, 13" diameter x 5.5" wide x 8" hub diameter. Tandem load wheels are 6" diameter polyurethane x 2.8" wide (4.25" wide for lift heights above 348"). Optional polyurethane aisle guide wheels are 2" wide with a 4" or 2.5" diameter.

Forks

2" thick x 4" wide forged steel. Fork spread (adjustable) 24" to 30". Standard length is 36". Optional lengths available.

Pallet Clamp

Standard equipment includes a foot-applied, hand-released pallet clamp designed for use with pallets having center stringers.

Safety Shield

Safety glass to protect operator from chains and moving parts while in his normal operating position.

Audible Travel Alarm Option

Safety considerations and dangers associated with audible travel alarms include:

- Multiple alarms can cause confusion.
- Workers ignore the alarms after day-in and day-out exposure.
- Operator may transfer the responsibility for "looking out" to the pedestrians.
- Annoys operators and pedestrians.

Other Options Available

Contact your local Crown dealer.

Dimensions and performance data given may vary due to manufacturing tolerances. Performance is based on an average size vehicle and is affected by weight, condition of truck, how it is equipped and the conditions of the operating area. Crown products and specifications are subject to change without notice.



You can count on Crown to build lift trucks designed for safe operation, but that's only part of the safety equation. Crown encourages safe operating practices through ongoing operator training, safety-focused supervision, maintenance and a safe working environment. Go to crown.com and view our safety section to learn more.

Crown Equipment Corporation

New Bremen, Ohio 45869 USA

Tel 419-629-2311

Fax 419-629-3796

crown.com

Because Crown is continually improving its products, specifications are subject to change without notice.

Crown, the Crown logo, the color beige, the Momentum symbol, Work Assist, Access 1 2 3, InfoLink and InfoPoint are trademarks of Crown Equipment Corporation.

Copyright 2005 Crown Equipment Corporation
SF14832 10/07
Printed in U.S.A.

Free Manuals Download Website

<http://myh66.com>

<http://usermanuals.us>

<http://www.somanuals.com>

<http://www.4manuals.cc>

<http://www.manual-lib.com>

<http://www.404manual.com>

<http://www.luxmanual.com>

<http://aubethermostatmanual.com>

Golf course search by state

<http://golfingnear.com>

Email search by domain

<http://emailbydomain.com>

Auto manuals search

<http://auto.somanuals.com>

TV manuals search

<http://tv.somanuals.com>